

Building Envelope Thermal Bridging Guide

VERSION 1.6

2021

TABLE OF CONTENTS

1. OVERVIEW.....	1
2. GLOSSARY OF TERMS	3
3. METHODOLOGY FOR DETERMINING THERMAL PERFORMANCE OF BUILDING ENVELOPE ASSEMBLIES.....	7
3.1 DETERMINING THERMAL PERFORMANCE OF CLEAR FIELD ASSEMBLIES	8
3.2 DETERMINING THERMAL PERFORMANCE OF INTERFACE DETAILS – AREA WEIGHTED APPROACH	8
3.3 DETERMINING THERMAL PERFORMANCE OF INTERFACE DETAILS UTILIZING LINEAR TRANSMITTANCES.....	9
3.4 DETERMINING OVERALL THERMAL PERFORMANCE.....	10
4. SUMMARY OF THE THERMAL PERFORMANCE CATALOGUE	17
4.1 CATALOGUE BREAKDOWN.....	17
4.2 THERMAL PERFORMANCE CATEGORIES.....	18
4.3 OTHER SOURCES OF INFORMATION	23
5. EXAMPLE UTILIZATION OF THE CATALOGUE.....	25
6. INPUTTING THERMAL VALUES INTO ENERGY MODELS	31
7. REFERENCES	32

APPENDIX A: CATALOGUE MATERIAL DATA SHEETS

APPENDIX B: CATALOGUE THERMAL DATA SHEETS



ACKNOWLEDGEMENTS

This Building Envelope Thermal Bridging Guide was prepared by Morrison Hershfield Limited in collaboration with many stakeholders and industry partners. We would like to thank the organizations and individuals that made this undertaking possible.

The Project Co-Sponsors

BC Hydro Power Smart
BC Housing
CMHC
Canadian Wood Council
Fortis BC

FPInnovations
Manitoba Hydro
National Resources Canada
Transition énergétique Quebec

Industry Advisors

The following organizations were included as industry advisors for the completion of the guide.

Architectural Institute of British Columbia (AIBC)
Building and Safety Standards Branch, BC
City of North Vancouver
Engineers and Geoscientists British Columbia (EGBC)
Fenestration Association of BC (FEN-BC)
Urban Development Institute (UDI)

We wish to also gratefully thank the following individuals for their active participation in steering this guide to completion.

Bojan Andjelkovic, BC Hydro
Curt Hepting, EnerSys Analytics Inc
Dan Bradly, FortisBC
Denisa Ionescu, BC Housing
Gordon Monk, BC Hydro
Jieying Wang, FPInnovations
Jim Kobialko, FortisBC

Jonathan Meads, Concert Properties
Oscar Ceron, BC Hydro
Peggy Lepper, Canadian Wood Council
Remi Charron, BC Housing
Robert Jonkman, Canadian Wood Council
Tim Ryce, City of North Vancouver

Industry Partners

We wish to extend a special thanks to the manufacturers and industry partners that helped extend the scope of the thermal performance catalogue. Thanks to the support and contributions of the following industry partners: ACS Composite Systems, Armadillo NV, BV Glazing, Canadian Sheet Steel Building Institute (CSSBI), Dow Corning Corporation, EIFS Council of Canada, EJOT Construction Fastening Systems Inc. (EJOT), Fero, Hohmann & Barnard, JK Thermal, Owens Corning Canada, Schöck Bauteile GmbH, Tnemec and the manufacturers of proprietary cladding attachments (American Fiber Cement Corporation, Cascadia Windows, CL Talon, ECO Cladding, Engineered Assemblies, ETG, Knight Wall, Mayne Coatings, Northern Facades, Nvelope, SOPREMA, Technoform, U-Kon Systems. These industry partners provided the funding to evaluate many variations of solutions that mitigate the impact of thermal bridging.

Preparation of the Guide

We acknowledge the team at Morrison Hershfield Ltd. for their dedication, insight, and collaborated effort in preparing this guide. MH's team included the following individuals:



Alex Blue, Barilelo Nghana, Christian Cianfrone, David Fookes, Eileen Holt, Fabio Almeida, Ivan Lee, Jameson Vong, Julien Schwartz, Katie Hay, Mark Lawton, Matthew Doiron, Felipe Merino Gordo, Michael van der Laan, Neil Norris, Nick Adamson, Patrick Roppel, Radu Postole, and Ruth McClung.

We acknowledge the team at Open Technologies for their work developing the online version of the BETB, available at thermalenvelope.ca. Open's team included the following individuals: Ryan McCuaig, Christian Cianfrone, Daniel Eden, and Andrew Shopland.

What's New in [Version 1.6](#)

BETB Version 1.6 is the fourth and final major expansion of the BETB catalog and part of a larger project to transform the BETB Guide into a Canada-wide resource.

This project includes an easy-to-use, web-based database to support the industry in fully recognizing the impact of thermal bridging in energy codes and in practice. When completed, the expanded BETB database and web-application will be applicable to all Canadian climates, current construction practices, energy codes, and construction types. The database will also include details and systems that are needed to meet future requirements for net-zero buildings.

This version adds 26 new details and 95 new scenarios of generic details and assemblies. A summary of the additional details follows. The discussion of performance categories for thermal bridging details has also been expanded to include categories for point transmittances.

New assemblies have been added to the database, including precast-concrete, wood-framed, low sloped roofing systems, and insulated concrete form (ICF) foundations. Details have been added for mitigating thermal bridges at interface details, including the window to wall transition, intermediate floors, roof penetrations, and base of wall details at foundations. Additional insulation scenarios have been added to walls and roofs from previous versions of the BETB guide providing solutions for all Canadian climates zones and low TEDI/ net-zero buildings.



DISCLAIMER

This publication is provided to inform the practice of applying the Building Envelope Thermal Analysis (BETA) methodology for determining the effective thermal performance of building envelope assembly and interface details, as well as to guide BETA's application in overall building design. The greatest care has been taken to confirm the accuracy of the information contained herein. However, the authors, co-sponsors, industry advisors, industry partners and other contributors assume no liability for any damage, injury, loss or expense that may be incurred or suffered as result of the use of this publication, building envelope design methodology or energy modelling practices. The views expressed herein do not necessarily represent those of any individual contributor. Nothing in this publication is an endorsement of any proprietary building envelope system or particular assembly product.

In addition to using this publication, readers are encouraged to consult applicable up-to-date technical publications on building envelope science, practices and products. Retain consultants with appropriate architectural and/ or engineering qualifications and speak with appropriate municipal and other authorities with respect to issues of envelope design, assembly fabrication and construction practices. It is also advisable to seek specific information on the use of envelope-related products and consult the instructions of envelope assembly manufacturers. Always review and comply with the specific requirements of the applicable building codes for any construction project.

Copyright © 2021, all rights reserved.
BC Hydro Power Smart
333 Dunsmuir Street
Vancouver, BC
V6B 5R3



1. OVERVIEW

In British Columbia, a large percentage of electricity and natural gas is consumed in commercial, institutional, and residential buildings. Improved energy conservation in buildings has long been recognized as an important approach to reduce energy consumption and greenhouse gas emissions in BC. Government and utilities have a mandate to encourage energy conservation in buildings and BC jurisdictions have been adopting increasingly more stringent building energy efficiency standards. Space conditioning, primarily heating, is one of the largest components of energy use in commercial, institutional, and residential buildings in BC. Building envelope thermal performance is a critical consideration for reducing space heating loads and will be an increasingly important factor as authorities strive for lower energy consumption in buildings.

It has become more and more evident that the thermal performance of the building envelope can be greatly affected by thermal bridging. Thermal bridges are localized areas of high heat flow through walls, roofs and other insulated building envelope components. Thermal bridging is caused by highly conductive elements that penetrate the thermal insulation and/or misaligned planes of thermal insulation. These paths allow heat flow to bypass the insulating layer, and reduce the effectiveness of the insulation.



Figure 1: Thermal Bridging due to a Shelf Angle that supports Brick Veneer

Research and monitoring of buildings is increasingly showing the importance of reducing thermal bridging in new construction and mitigating the impact in existing buildings. The impact can be significant to whole building energy use, the risk of condensation on cold surfaces, and occupant comfort. The traditional approach of building codes to reducing space heating loads in buildings was to introduce progressively higher levels of thermal insulation and more stringent glazing performance requirements. This was a logical approach in the past because standard practice was to largely overlook thermally bridging. The effects of thermal bridging were assumed to be negligible if the cross-sectional areas of these conductive components were small, relative to the rest of the building envelope or they were purposely ignored due to the difficulty in assessing the impact. However, the additional heat flow due to major thermal bridges, including ones with small cross sectional areas such as shelf angles or flashing around windows, can add up to be a significant portion of the heat flow through opaque envelope assemblies. For example, the contribution of details that are typically disregarded can result in the underestimation of 20% to 70% of the total heat flow through walls. If major thermal bridges are not addressed then adding insulation to the assemblies may not provide significant benefits in reducing the overall heat flow because heat will flow through the path of least resistance. The cost of adding extra insulation, not just additional materials but also potentially reduced useable floor space, is not justified if no substantial energy savings are realized in practice.

Energy standards and codes in BC jurisdictions (BCBC, VBBL, ASHRAE 90.1 and NECB) do not currently effectively address, or explicitly allow designers to ignore, major thermal bridges such as slab edges, shelf angles, parapets, window perimeters, etc. These codes and standards have steadily increased their insulation requirements but the development and implementation of procedures to effectively address thermal bridging in these codes has been slow. Some reasons for the slow response include: absence of data, the complexity of some prevailing procedures to account for thermal bridging, and a lack of clear information demonstrating that thermal bridging needs to be more thoroughly addressed. Moreover, reaching agreement for how to implement

significant changes to codes and standards can be challenging for committees comprised of a wide range of interests, backgrounds and perspectives.

With this context in mind, the original guide explored how the building industry in BC can realistically meet the challenges of reducing energy use in buildings, in part by effectively accounting for the impact of thermal bridging. The goal of the co-sponsors of the BETB guide is to help transform the BC construction sector to realize more energy efficient buildings. To help meet this goal, the primary objective of the original BETB guide was to address the obstacles currently confronting our industry, with regard to thermal bridging, by:

1. Providing a catalogue of the thermal performance of common envelope assemblies and interface details directly relevant to construction in BC.
2. Providing information that makes it easier for industry to comprehensively consider thermal bridging in building codes and bylaws, design, and whole building energy simulations.
3. Examining the costs associated with improving the thermal performance of opaque building envelope assemblies and interface details, and forecasting the energy impact for several building types and BC climates.
4. Evaluating the cost effectiveness of improving the building envelope through more thermally efficient assemblies, interface details, and increasing insulation levels.

Scope

It is important to recognize that this guide is deliberately narrow in scope. The focus is on the thermal performance of the opaque building envelope. A wide range of opaque assemblies were evaluated in preparation of this guide; however, the thermal performance of the opaque building envelope is only one of many considerations for reducing energy use in buildings and its relative impact changes as other building energy uses are reduced. Refer to the original version of the BETB Guide released in 2014 for the energy savings and cost benefit analysis (Part 2) and sections related to market transformation (Part 3: Significance, Insights and Next Steps).

Audience

The target audiences for this guide are broad: committees for energy standards, policy and government, utilities, architects, mechanical designers, building envelope consultants, energy modellers, developers and contractors, manufacturers and trade organizations. Not all the information contained in the guide will be of direct interest to all these industry stakeholders.

2. GLOSSARY OF TERMS

Term	Symbol	Units Imperial	Units SI	Description
Conductivity	K	$\frac{\text{(BTU in)}}{\text{(hr ft}^2 \text{ }^\circ\text{F)}}$	$\frac{\text{W}}{\text{(m K)}}$	The ability of a material to transmit heat in terms of energy per unit area per unit thickness for each degree of temperature difference.
Equivalent Conductivity	K_{eq}	$\frac{\text{(BTU in)}}{\text{(hr ft}^2 \text{ }^\circ\text{F)}}$	$\frac{\text{W}}{\text{(m K)}}$	The averaged or equivalent thermal conductivity of a component consisting of several building materials, effectively treating the component as a homogeneous material that provides the same thermal characteristics.
Heat Flow	Q	BTU/hr	W	The amount of energy per unit time that passes through an assembly under a specific temperature drive of ΔT .
Thermal Transmission Coefficient	U	$\frac{\text{(BTU)}}{\text{(hr ft}^2 \text{ }^\circ\text{F)}}$	$\frac{\text{W}}{\text{(m}^2 \text{ K)}}$	Heat flow per unit time through a unit area of an assembly per temperature degree difference. The convention is to include the impact of air films
Thermal Resistance of a Material	R	$\frac{\text{(hr ft}^2 \text{ }^\circ\text{F)}}{\text{(BTU)}}$	$\frac{\text{(m}^2 \text{ K)}}{\text{W}}$	A measure of a material's resistance to heat flow.
Effective Thermal Resistance	R_{eff}	$\frac{\text{(hr ft}^2 \text{ }^\circ\text{F)}}{\text{(BTU)}}$	$\frac{\text{(m}^2 \text{ K)}}{\text{W}}$	A measure of an assembly's resistance to heat flow, including the effects of thermal bridging. The inverse of the assembly U-value.
Clear field Assembly Thermal Transmittance	U_o	$\frac{\text{(BTU)}}{\text{(hr ft}^2 \text{ }^\circ\text{F)}}$	$\frac{\text{W}}{\text{(m}^2 \text{ K)}}$	Heat flow coefficient for an assembly with uniformly distributed thermal bridges, which are not practical to account for on an individual basis for U-value calculations. Examples of thermal bridging included in U_o are brick ties, girts supporting cladding, and structural studs.
Linear Heat Transmittance Coefficient	Ψ	$\frac{\text{(BTU)}}{\text{(hr ft }^\circ\text{F)}}$	$\frac{\text{W}}{\text{(m K)}}$	Heat flow coefficient representing the added heat flow associated with linear thermal bridges that are not included in the clear field U_o . Linear thermal bridges typically occur at interface details. Examples are shelf angles, slab edges, balconies, corner framing, parapets, and window interfaces.
Point Heat Transmittance Coefficient	χ	$\frac{\text{(BTU)}}{\text{(hr }^\circ\text{F)}}$	$\frac{\text{W}}{\text{(K)}}$	Heat flow coefficient representing the added heat flow associated with a point thermal bridge that is not included in the clear field U_o . Point thermal bridges are countable points and are considered feasible to account for on an individual basis for U-value calculations. An example is a structural beam penetration through insulation.
Length of a Linear Transmittance	L	ft	m	The length of a linear thermal bridge, i.e. height of a corner or width of a slab.

Term	Description
Air Films	An approximation of the combined radiative and conductive-convective heat exchange at air boundary surfaces.
Area of Influence	The area that heat flow through an assembly is affected by a thermal bridge by lateral heat flows.
Area Weighted Method	The method by which an average U-value is determined by summing the Area multiplied by U-Value of each component and then dividing by total Area. This method assumes parallel heat flow paths.
At-Grade Interface Detail	An interface detail at the transition between the above-grade wall assembly intersections with either an at-grade floor slab or below grade assemblies.
Building Elevation	A view of a building seen from one side, a flat representation of one façade. Elevations drawings typically show views of the exterior of a building by orientation (North, East, South or West).
Building Envelope	The elements of a building that separate the conditioned space from unconditioned space of a building. This includes walls, roofs, windows and doors.
Clear Field Assembly	Wall, floor and roof assemblies of a building. (see definition of U_0 above).
Corner Interface Detail	Where walls meet at a corner of the building. Interface details can have additional heat flow than compared to the clear field assembly because of additional framing and related to the geometry (increased exterior surface area).
Curtain Wall	A non-load bearing building façade that sits outboard of the main building structure made up of metal framing, vision glass and spandrel sections. The curtain wall only carries its own dead-load and lateral loads (wind).
Dynamic Thermal Response	The time variant heat flows through the building envelope that result in delayed heat gain or loss depending on the amount of energy that is stored within the building envelope. The amount of energy that is stored within the building envelope at any given time is related to the mass of all the combined components of the building envelope (thermal mass).
Eyebrow	An architectural feature where the floor slab projects beyond the walls. Eyebrows often provide overhead protection from rain for fenestration and are similar in construction to a balcony.
Fenestration	All areas (including the frames) in the building envelope that let in light, including windows, plastic panels, clerestories, skylights, doors that are more than one-half glass, and glass block walls.
Firestop	A fire protection system made of various components used to seal openings and joints in fire-resistance rated wall and floor assemblies.
Floor Space Ratio	Ratio of gross floor area of a building to the area of land on which it is built.
Glazing	See definition of fenestration. Examples of glazing are windows, window-wall, and curtain-wall.
Glazing Interface Detail	Linear thermal bridges that occur at the intersection of glazing and opaque assemblies.

Term	Description
Insulating Glass Unit (IGU)	Double or triple glass planes separated by air or other gas filled space. The space between the panes is glass is created by a physical spacer that is also adhered to the glass. Sealant is provided at the perimeter of the unit as a gas and moisture barrier.
Interface Details	Thermal bridging related to the details at the intersection of building envelope assemblies and/or structural components. Interface details interrupt the uniformity of a clear field assembly and the additional heat loss associated with interface details is accounted for by linear and point thermal transmittances.
Lateral Heat Flow	Heat flow in multiple directions through an assembly as a result of conductive components bypassing the thermal insulation in multiple dimensions.
Linear Thermal Bridge	An interface detail that can be defined by a linear length along a plane of the building envelope.
MURB	Multi-unit residential building.
Opaque Assembly	All areas in the building envelope, except fenestration and building services openings such as vents and grilles.
Parallel Path	The assumption that the heat flow paths through an assembly are perpendicular to the plane of the assembly and there is no lateral heat flow.
Parapet	An interface detail that joins the walls to the roof.
Point Thermal Bridge	Points of heat loss that are considered feasible to account for on an individual basis for U-value calculations. An example is a structural beam penetration through insulation.
Poured-in-Place Concrete Wall	An architectural exposed concrete wall that is formed at the location of installation and is part of the building structural support.
Precast Concrete Wall	An architectural concrete cladding that is formed off site and shipped to the location of installation.
Plane of Heat Transfer	The theoretical projected area between the interior and exterior environment where the net heat flow through the building envelope is calculated.
Plug Loads	Any system that draws electrical power through the building but is not explicitly used to operate the building. This includes appliances, computers and other items that are dependent on the occupants use.
Setpoint Temperature	The desired operating temperature that a heating system works to maintain, ie: the interior space temperature set by a thermostat.
Shelf Angle	A structural support that transfers the dead load of brick veneer to the building structure at the floor slab.
Floor Slab	A concrete floor that partially or fully penetrates the building envelope at the exterior.
Slab Bypass	A portion of window-wall that covers the floor slab edge to give the appearance of uninterrupted glazing across the entire façade of a building.
Spandrel Section	An opaque section of curtain wall or window wall with insulation between the system framing.

Term	Description
Stick Built Curtain Wall	A site installed and glazed curtain-wall system that is assembled by running long pieces of framing between floors vertically and between vertical members horizontally.
Structural Beam	A steel beam that penetrates through the building envelope to support an exterior element, such as a canopy.
Quantity Takeoff	A quantity measurement that determines the areas and lengths needed for U-value calculations. The quantities are determined using architectural drawings.
Thermal Break	A non-conductive material that interrupts a conductive heat flow path. For example, aluminum framing for glazing in cold climates typically utilizes a low conductivity material to join an exterior and interior portion of the metal framing.
Thermal Bridge	Part of the building envelope where otherwise uniform thermal resistance is changed by full or partial penetration of the thermal insulation by materials with lower thermal conductivities and/or when the interior and exterior areas of the envelope are different, such as what occurs at parapets and corners.
Thermal Modeling	The process by which the thermal performance of assemblies is determined through computer simulations utilizing heat transfer models. Assemblies can be modeled two- or three- dimensions (2D and 3D).
Thermal Performance	A broad term to describe performance indicators related to the heat transfer through an assembly. The performance indicators include thermal transmittances, effective R-values, and metrics to evaluate condensation resistance related to surface temperatures.
Thermal Zone	A grouping of the interior building spaces that experience similar heating and cooling requirements.
Total Energy Use	The amount of annual energy use of a building, including space heating/cooling, ventilation, lighting, plug loads, domestic hot water, pumps, fans etc.
Unitized Curtain Wall	A curtain-wall system that is assembled in modules that is glazed before arriving at site.
Vision Section	The section of curtain-wall or window-wall that contains transparent or translucent elements.
Window to Wall Ratio/ Glazing Ratio	The percentage of glazing to the wall area of a building.
Window-wall	A factory built modular façade system installed from floor to ceiling that is supported by the floor slab. This could include a vision and a spandrel section.
Whole Building Energy Use	The amount of energy a building uses, typically on a yearly basis. This includes, but is not limited to, energy for space and ventilation heating and cooling, domestic hot water heating, lighting, miscellaneous electrical loads and auxiliary HVAC equipment such as pumps and fans.

3. METHODOLOGY FOR DETERMINING THERMAL PERFORMANCE OF BUILDING ENVELOPE ASSEMBLIES

The performance data prepared for this guide was determined by following the same methodology as 1365-RP and using the same 3D thermal modeling package that was extensively calibrated and validated as part of that work. Detailed information on the background of the methodology can be found in the final report for 1365-RP. What follows is an outline of the important points of that methodology.

In determining the thermal performance of the building envelope that includes thermal bridging, a basic distinction must be made between two types of opaque building components, clear field assemblies and interface details, examples of which are shown in Figures 2 and 3 respectively.

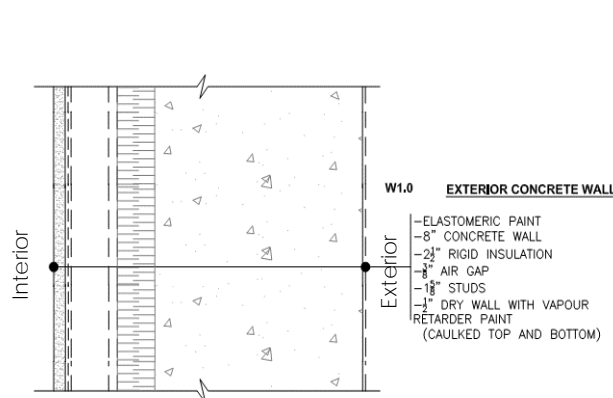

Figure 2: An example of a clear field assembly drawing

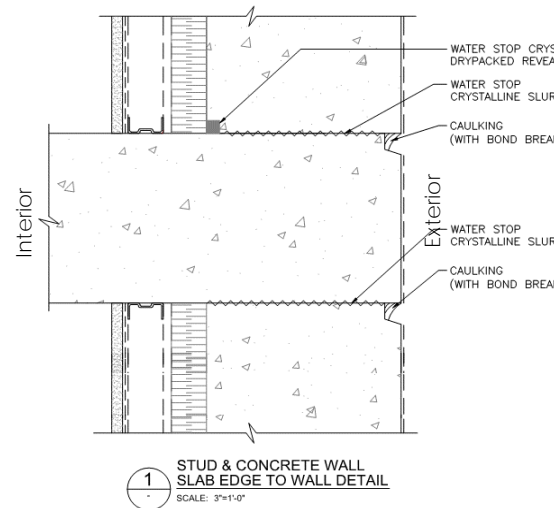

Figure 3: An example of an envelope interface detail drawing

Clear field assemblies are wall, roof or floor assemblies that include all the components that make up a wall, including structural framing. These are typically found in the architectural drawings in the wall/roof/floor schedules. Clear field assemblies can contain thermal bridges from uniformly distributed secondary structural components which are needed for the wall to resist loads, but do not include thermal bridges related to intersections to the primary structure or between assemblies. Examples of components included in clear field assemblies are brick ties, girts that support cladding and/or studs.

Interface details are changes in construction or geometry that interrupt the uniformity of the clear field. These are typically found in the detail sections in architectural drawings. These include slab edges, opaque to glazing or wall transitions, parapets, corners and through wall penetrations.

Determining the impact of heat flows through the clear field and through interface details is necessary to accurately assess the thermal transmittance of building envelope assemblies.

A Note on Glazing

Glazing in buildings can have an incredibly large influence on building energy use, especially in designs that have high window to wall ratios. Glazing portions of the building envelope are often dealt with separately from the opaque elements because of the additional effects of solar heat gain. Thermal analysis and testing of glazing systems in North America typically follow standards by the National Fenestration Rating Council (Mitchell, et al., Rev 2013). Following this guide to determine the thermal performance of opaque elements and NFRC standards for glazing is compatible. While the thermal performance of glazing assemblies can affect the thermal resistance of adjacent wall or roof assemblies, the heat loss is accounted for through the window to wall transition thermal values described later in this guide.

3.1 DETERMINING THERMAL PERFORMANCE OF CLEAR FIELD ASSEMBLIES

The thermal performance of clear field assemblies can be determined through calculation, modeling or physical testing. Typically this takes the form of a U-value or effective R-value.

- The **ASHRAE Handbook of Fundamentals** (ASHRAE, 2013) provides several methods to determine clear field U-values using hand calculations. These hand calculations are meant for simple assemblies with only thermal bridges in one or two dimensions. These methods are described in more detail in the Handbook of Fundamentals.
- For assemblies where the 2D heat flow paths can influence each other and are more complex than appropriate for hand calculations, then 2D thermal modeling can be utilized to approximate the thermal performance of building envelope details. Software for this type of modeling (such as **THERM**, (Mitchell, et al., Rev 2013) is widely available and used in industry for two-dimensional thermal modeling. Approximations need to be made for components that are not continuous or occur in three dimensions, such as creating an equivalent thermal conductivity. These approximations can be sufficient in many cases for determining the expected thermal transmittance of opaque assemblies, but cannot be used to determine surface temperatures.
- For complex geometries and configurations where 2D heat flow assumptions are no longer valid, then 3D modeling or physical testing is often necessary for more accurate approximations of thermal performance. As stated previously, the clear field and detail values prepared for this guide were determined through 3D modeling.

It is typically only necessary to model or test a clear wall assembly if it is a new or unique design when information is not available. The construction industry has a wide variety of resources accessible to designers which contain thermal performance values for many types of clear field assemblies. Clear field assemblies analyzed for this guide are discussed in section 4.1 with additional information and thermal performance values provided in Appendices A and B. Other sources of information beyond this guide are discussed further in section 4.3.

3.2 DETERMINING THERMAL PERFORMANCE OF INTERFACE DETAILS – AREA WEIGHTED APPROACH

Area weighted calculations are commonly used to calculate U-values or effective R-values of the combined effect of assemblies and interface details. Typically, this is done by weighting the heat flow through the materials by the area they take up. While this can be applied easily to simple clear field assemblies, the question that arises when applied to interface details is **what is the area of a thermal bridge?**

Using only the physical area of a thermal bridge assumes that the heat flow paths through an interface detail are one-dimensional and parallel. Unfortunately, this is rarely true, and highly conductive building components create lateral heat flows to other components in three dimensions that are not accounted for in basic parallel flow assumptions. A steel shelf angle holding up a brick wall may seem small from the outside, but it is connected to many other components behind the brick and heat can easily flow around the insulation.

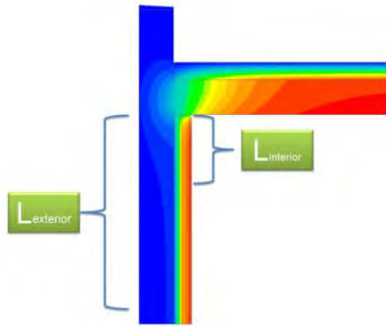

Figure 4: Areas of influence of a parapet detail differ from the interior and exterior of the wall

To improve simple parallel path assumptions, an area of influence of a thermal bridge has been utilized in the past. This requires finding out the distance where the heat flow through the assembly is no longer affected by the thermal bridge. The heat flow through this area is then used as a combined U-value for the wall and the thermal bridge. However, determining areas of influence of many common thermal bridges is incredibly difficult. Lateral heat flows caused by conductive elements allow heat to be transferred in multiple directions for large distances. This can create large differences in areas of influence depending on whether you are looking from inside or outside.

Using the area weighted approach can produce reasonable results when analyzing structures with low thermal conductive structural members, such as some wood-frame configurations. However, this approach can be complicated and difficult to use

in practice for detailed analysis of the heat transfer through building envelopes constructed with moderate to highly conductive materials like concrete, steel and aluminum.

3.3 DETERMINING THERMAL PERFORMANCE OF INTERFACE DETAILS UTILIZING LINEAR TRANSMITTANCES

Linear and point transmittances can simplify things by ignoring the area of thermal bridges altogether. With this approach, the heat flow through the interface detail assembly is compared with and without the thermal bridge, and the difference in heat flow is related to the detail as heat flow per a linear length or as a point heat flow.

To illustrate how this works, let's apply this method to an exterior insulated steel stud wall with a cantilevered balcony slab that is a direct extension of the concrete structural floor slab, as shown in Figure 5:

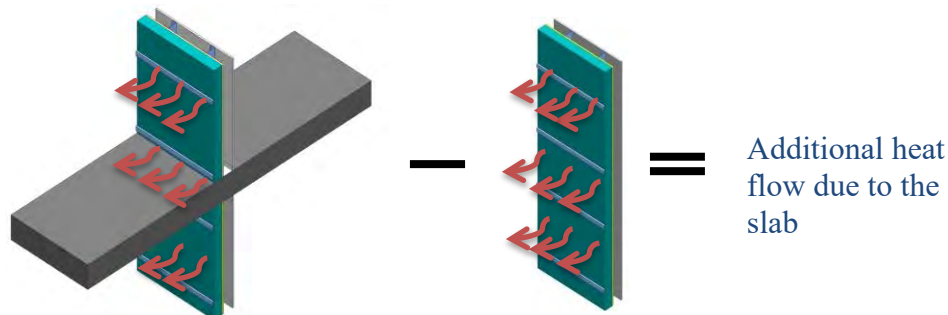

Figure 5: Determining linear transmittance for a slab

First, the heat flow through the interface detail assembly with the slab is determined. Next, the heat flow is determined through the assembly as if the slab was not there (you may recognize this as the clear field assembly). Since the clear field does not contain the slab, which is a large

thermal bridge, the amount of heat flow is less. The difference in overall heat flow between the two assemblies is the extra amount caused by the balcony/floor slab bypassing the thermal insulation. Dividing by the assembly width (linear length of the slab edge) creates the linear transmittance of the slab, which is a heat flow per linear length.

With linear transmittances, the extra heat flow prescribed to the floor slab is not dependent on the area of the thermal bridge, but only by the linear length (width) of the balcony slab. A point transmittance is similar in concept, but is a single point of additional heat flow, not dependent on area or length. Since the linear and point transmittances are separate from the clear field, they can be directly compared to assist in determining the most appropriate details for a building. Calculated linear and point transmittances along with the clear field transmittance can be used to determine the overall heat flow for any size of wall or roof that use those components.

As with the clear field assemblies, there are additional information sources that have thermal performance values for common linear and point transmittances, albeit they are not as widely available. The performance catalogue in this guide, discussed in section 4, consolidates several of the linear and point transmittance as determined using the method set forth in 1365-RP. However, there are other sources available which are detailed further in section 4.3.

Superimposing Heat Flows

Another way of looking at the basic concept of linear transmittance is by superimposing the heat flows from the full assembly, with an interface detail, and the clear field assembly, without the interface detail, over top of each other.

From this figure you can visualize the lateral heat flows to the path of least resistance through the interface detail assembly (i.e. through the slab). This results in a higher heat flow at the slab compared to if it was only the clear field. Far away enough from the slab and the heat flow reaches the same level as in the clear field. By subtracting the clear field from the total interface detail assembly leaves the additional heat flow from just the slab, from which we get the linear transmittance.

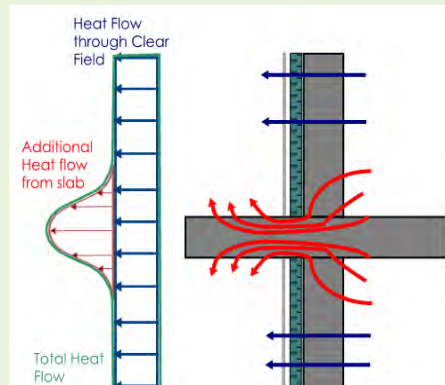

3.4 DETERMINING OVERALL THERMAL PERFORMANCE

The thermal performance values of each of the envelope components can be used to calculate an overall thermal transmittance (U-value) for building envelope assemblies that include thermal bridging. Summarizing the approach so far, the thermal transmittances used in the calculations comprise of three separate categories:

- **Clear field transmittance** is the heat flow from the wall, floor or roof assembly. This transmittance includes the effects of uniformly distributed thermal bridging components, like brick ties, structural framing like studs, and structural cladding attachments that would not be practical to account for on an individual basis. The clear field transmittance is a heat flow per area, and is represented by a U-value denoted as the clear field (U_o).
- **Linear transmittance** is the additional heat flow caused by details that are linear. This includes slab edges, corners, parapets, and transitions between assemblies. The linear transmittance is a heat flow per length, and is represented by psi (Ψ).

- Point transmittance** is the heat flow caused by thermal bridges that occur only at single, infrequent locations. This includes building components such as structural beam penetrations and intersections between linear details. The point transmittance is a single additive amount of heat, represented by chi (χ).

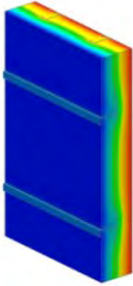

Figure 6: Example clear field assembly

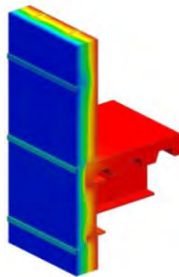

Figure 7: Example linear transmittance of a floor slab detail

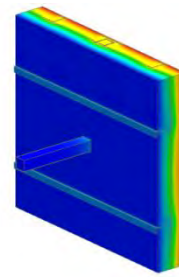

Figure 8: Example point transmittance of a beam penetration detail

The overall U-value for any building envelope section is a simple addition and multiplication process. In straightforward terms this amounts to:

$$\text{Total Heat flow per area through the overall assembly} = \frac{\text{Heat flow through linear transmittances} + \text{Heat flow through point transmittances}}{\text{Total Area of assembly}} + \text{Heat flow per area through clear field assembly}$$

Or, in mathematical terms:

$$U_T = \frac{\Sigma(\Psi \cdot L) + \Sigma(\chi)}{A_{Total}} + U_o$$

Where:

U_T =	total effective assembly thermal transmittance (Btu/hr·ft ² ·°F or W/m ² K)
U_o =	clear field thermal transmittance (Btu/hr·ft ² ·°F or W/m ² K)
A_{total} =	the total opaque wall area (ft ² or m ²)
Ψ =	heat flow from linear thermal bridge (Btu/hr·ft °F or W/mK)
L =	length of linear thermal bridge, i.e. slab width (ft or m)
χ =	heat flow from point thermal bridge (Btu/hr· °F or W/K)

There are multiple types and quantities of linear and point transmittances, but they are all added to the clear field heat flow to get the overall heat flow of an area of the building envelope. The length for the linear transmittance depends on the detail. For example, the length used in the calculation for a floor slab bypassing the thermal insulation could be the width of the building perimeter, if this slab detail occurs around the whole façade of the building. Alternatively, a corner detail length could be the height of the building envelope. By finding the heat flows separately, each component can be evaluated to find their relative contribution to the overall heat flow.

The overall U-value for a building section can be found as long as the thermal performance values for the clear field, linear and point transmittances are known along with the quantities determined by architectural drawings. These transmittances can be calculated using the procedures put forth in 1365-RP; however, modeling every detail on a project would be impractical. As such, this guide provides an extensive catalogue of assemblies where the thermal performance values have already been calculated for designers. This catalogue is discussed in more detail in section 4.

3.4.1 FINDING LENGTH AND AREA TAKEOFFS

Determining the overall U-value of a building section using length and area takeoffs can be fairly straight forward i.e. slab lengths along the face of a building, or corner heights; however, there are some nuances when it comes to certain interface details. The following example shows the lengths and areas for a simple brick wall section.

Example: The overall opaque wall U-value is required for the brick wall section of a building that is adjacent to a curtain-wall system. From the analysis, the designer has determined that the brick wall section contains a parapet, slab, wall to window transition and corner detail. The designer finds the thermal performance values for the brick clear wall assembly and the linear transmittances for the interface details in a thermal performance catalogue. The length and area takeoffs are shown in Figure 9.

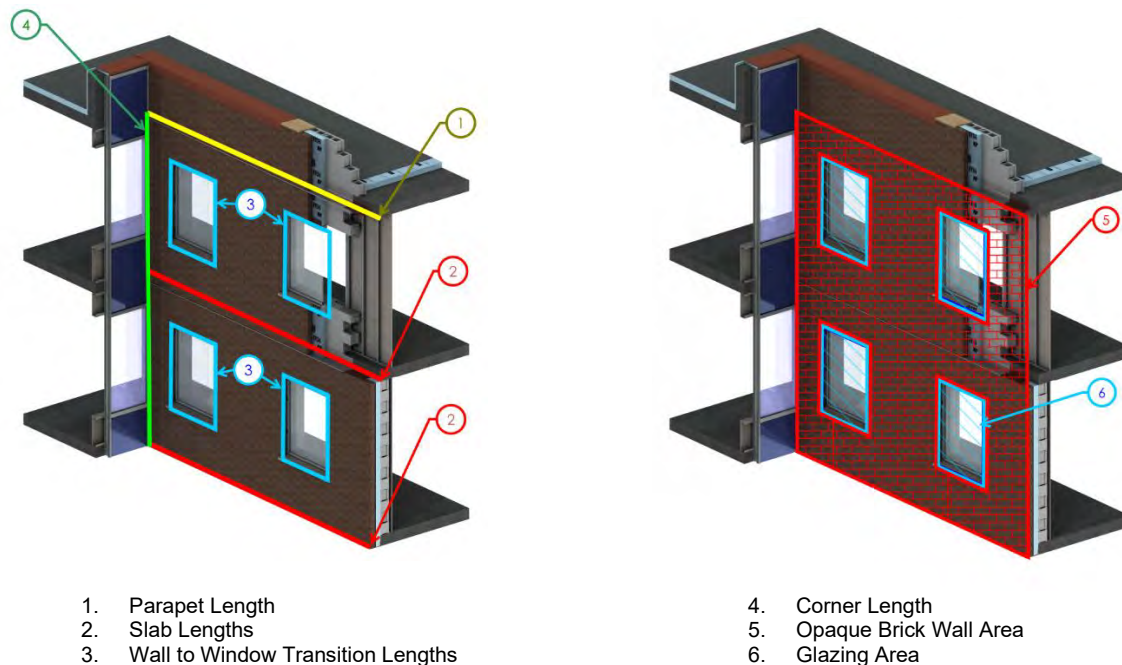

Figure 9: Example building length and area takeoffs

The glazing area above shows the differences between the glazing and opaque wall areas; however, glazing is not included with the opaque wall U-value calculations.

Once the thermal performance values of the clear wall and interface details are known, and the lengths and areas found, the overall U-value for the brick wall can be determined:

$$U_{overall} = \frac{\Psi_{parapet} \cdot L_{parapet} + \Psi_{slab} \cdot L_{slab} + \Psi_{transition} \cdot L_{transition} + \Psi_{corner} \cdot L_{corner}}{A_{Opaque\ Brick\ Wall\ Area}} + U_{brick\ clear\ wall}$$

For some of the interface details, there are additional considerations as to where to assign the extra heat flow. In the above example, the brick wall was connected to a curtain-wall system with spandrel. The corner interface detail is connected to both assemblies, and in the above calculation, the heat flow through the corner was assigned entirely to the brick wall. Alternatively, it could have been assigned entirely to the brick wall or the curtain-wall or split evenly between the two. It is up to the designer to decide how they wish to divide up the building U-values. This matters mostly for energy models as the heat flow through each envelope section gets assigned to a particular building thermal zone. This same concept applies to a parapet as it acts as a corner between the roof and the walls. However, it may not matter if the heat flow through the parapet is assigned to the wall or to the roof as both are connected to the same interior thermal zone. For wall to glazing transitions, the additional heat flow is assigned to the wall and not the glazing, thereby NFRC standards can be utilized for determining the U-value of glazing separately (Mitchell, et al., Rev 2013). When there are slabs, the clear wall area includes the projected area of slab edges, including balcony slabs.

Length and Area Takeoffs and the Plane of Heat Transfer

The plane of heat transfer for the building envelope is a theoretical projected area between the interior and exterior conditions through which heat flows. In order for there to be a heat loss or heat gain through the building envelope, energy must pass through this plane of heat transfer. A building assembly may have some elaborate features that extend out past the building envelope; however, all that is important for thermal performance is where the heat flow passes the plane of heat transfer into or out of the building.

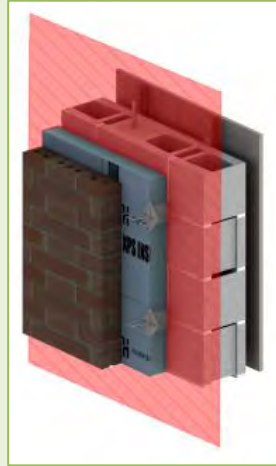

Plane of heat transfer through a wall

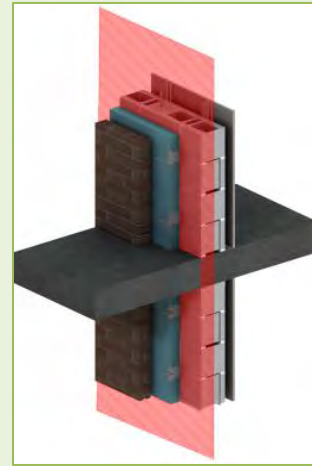

Plane of heat transfer through a projected balcony

For flat objects (i.e. walls) the plane of heat transfer is easy to visualize. With projections, such as balcony slabs, it may not be immediately intuitive where the plane is; however, since it is only important where the heat flows through the building envelope, the plane of heat transfer is the same as the flat wall. The areas of details that project out of the building envelope are not necessary for calculations. The heat flows as a result of these projections are accounted for in the linear transmittance of that detail. If there was a significant difference in heat flow as a result of the distance of the projection (i.e. a balcony that projected 1m from the wall compared to one that projects 3m from the wall) then there would be a different linear transmittance value. However, it should be noted that for the details in this guide, the projected distances of the balconies had minimal effect on the linear transmittance values for the projected slabs. When determining length takeoffs for projections for use in overall thermal performance calculations, only the lengths along the plane of heat transfer should be used. For example, for balcony slabs, use the length where the balcony intersects the wall and NOT the outside perimeter length of the balcony. Similarly for parapets, the length around the parapet is not needed.

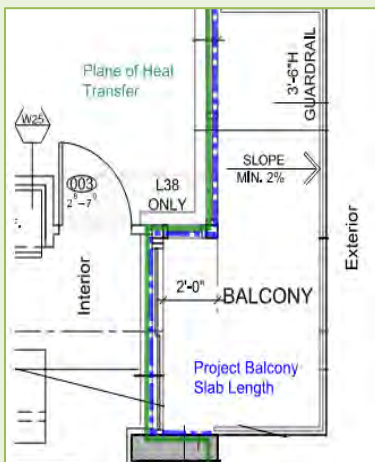

Correct Projected Balcony Slab Length for Calculations

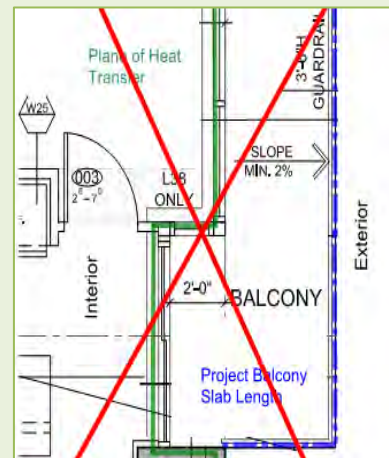

Incorrect Project Balcony Slab Length for Calculations

A Note on Length and Area Takeoffs for the Detail Oriented

The lengths for linear transmittances are usually easiest to find using building elevation drawings, which are exterior dimensions. Some further investigation for take offs may be required, such as looking at interior section views, when a detail is obstructed by other building features (i.e. the cladding). However, getting the takeoff lengths and areas from the exterior or the interior dimensions will result in slight differences on the overall U-value, depending on how the linear transmittances are reported. The way in which the linear transmittances are reported for this guide are such that if mixed interior and exterior dimensions are used, then the U-values will be slightly more conservative. This is typically not a concern as the differences from mixing interior and exterior dimensions are minor and there are already inherent discrepancies between architectural drawings and what is built on site. The following information is for those designers who want that extra level of precision.

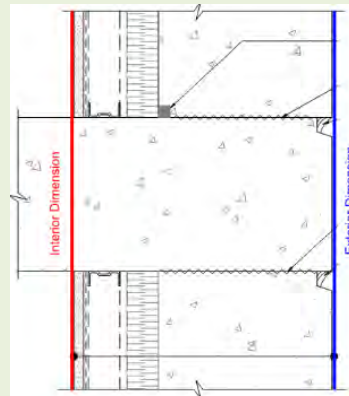

Interior/Exterior Dimensions for a single plane assembly

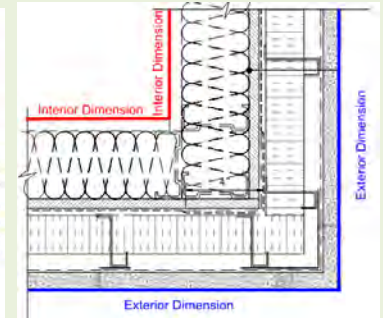

Interior/Exterior Dimensions for a multi-plane assembly

The formulation of linear transmittance values is dependent on the area of the plane of heat transfer through the modeled assembly. In most cases, figuring out the plane of heat transfer is straight forward. For straight building objects, like a wall, heat transfer between the interior and the exterior is in a single plane, through the wall, so the interior and exterior dimensions will be the same. However, for an angled detail like an outside corner, the heat transfer is in more than one plane and the interior and exterior dimensions are different.

Remembering that the linear transmittance is an extra heat flow caused by an interference detail compared to the clear field heat flow, the calculation of Ψ is dependent on the area of the clear field used in the calculation. Due to conservation of energy, the heat flow in equals the heat flow out, and the overall amount is the same regardless of the dimension chosen. However, assigning the degree of that heat flow between the clear field and the detail is where the issue lies.

Example: For the outside corner shown above, if the clear field area is assumed to be the interior dimensions, which are smaller, then the heat flow contribution from the clear field will be smaller and the rest is assigned to the corner. If the clear field is assumed to be the exterior dimensions, then the heat flow contribution through the clear field will be larger, with a smaller amount assigned to the corner. This results in a smaller or larger calculated linear transmittance depending on the dimension used, however, the resultant heat flow should be identical when the correct lengths are used in U-value calculations.

If a linear transmittance for a multi-plane assembly was determined using interior dimensions, and the takeoff lengths for the detail use exterior dimensions, then the heat flow through that detail will be slightly overestimated for outside corners and parapets since the exterior dimensions are typically larger than the interior dimensions. This overestimation is the same magnitude as using exterior dimensions for any U-value calculation and is equal to the clear field U-value multiplied by the difference in area between the interior and exterior dimensions.

To be most precise, the locations for the takeoffs in multi-plane assemblies should match with how the linear transmittance is reported. Alternatively, the difference between the interior and exterior dimensions on either side of the corner is actually just the wall thickness. The heat flow through a section of clear wall the size of the wall thickness could be subtracted from the overall heat flow in order to remove the overestimation. However, it should be noted that multi-plane assemblies are typically parapets and corners and this may only be a consideration in smaller buildings (less than four storeys) if the parapet or corner details have a high linear transmittance.

ISO 14683 (CEN, 2007) reports multiple linear transmittances for interface details based on different dimensioning systems. While this is thorough, the intent of the methodology in ASHRAE 1365-RP (Morrison Hershfield Ltd, 2011) was to simplify calculations; therefore only one transmittance value, reported from interior dimensions, is given per insulation level per interface detail in this guide. Differences in exterior and interior dimensions with linear transmittances are further discussed in (Janssens, et al., 2007).

Dealing with Floor to Ceiling Glazing

An issue that arises when determining lengths and areas for heat loss calculations is glazing that spans floor to ceiling. In the methodology presented in the guide, glazing and opaque envelope areas are accounted for separately when calculating heat loss, with additional heat loss from interface details added to the opaque areas. Thus, a situation arises when there is floor to ceiling glazing from slab to slab and there is no discernible opaque clear wall area.

In calculating the linear transmittance of a detail, the value is based on an additive amount of heat flow from the detail to the clear field assembly associated with that detail. For example, the linear transmittance of a balcony going through an interior insulated concrete wall is the difference in heat loss between the same sized assembly with and without the balcony there. In the calculations for the overall U-value, we prescribe an area to the total assembly, and a portion of that assembly is interrupted by details. We calculate the total U-value by adding the heat loss associated with thermal bridging at interface details to the clear field heat loss. However, with floor to ceiling glazing, the slab is flanked by glazing assemblies, which presents a situation where there is not an obvious clear wall thermal transmittance.

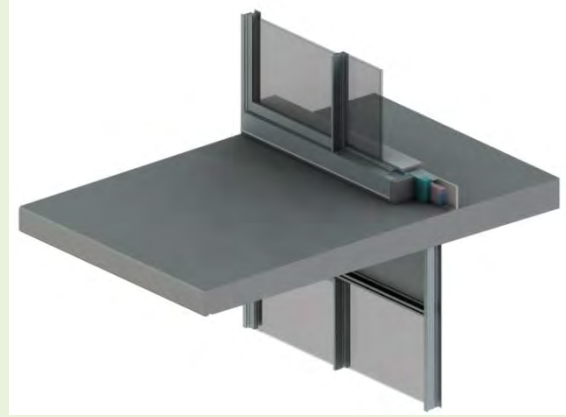

Assembly without an opaque clear field

The linear transmittances for the details in section 8.0 Balcones and Doors in Appendix A and B were calculated by subtracting out the glazing heat flow above and below the slab. There are many possible wall assemblies that can be adjacent to the balcony sliding door and balcony slab.

Using the linear transmittance values directly and including the areas of the slabs between the floor to ceiling glazing as clear field area may result in a more conservative overall U-value since the clear field area is being over accounted for. The results for the balcony details presented in Appendix B are presented in a few alternative formats than for the other interface details. The reason for this deviation is to allow the data to be applied broadly to many variations and to make the information easy and flexible to use. Balconies can be factored into U-value calculations using the following approaches.

1) U-value Approach

U-values of the opaque area of balconies are presented in the thermal performance data sheets in Appendix B. These U-values can be treated as its own wall assembly, or averaged into the adjacent assembly using an area weighted calculation. If using area weighted calculations, then the total projected area of the slabs need to be determined separately from the area of the adjacent walls.

2) Linear Transmittance without Area

Linear transmittances are provided in section 8.0 of Appendix B for balconies where it has been assumed there is no clear field. These values are essential a delta U that can be added to any adjacent wall assembly. However, in the calculations the clear wall heat loss should not include the area of the slabs. In the U-value equation given in section 1.25, the clear field U_o term should be corrected by multiplying it by the following factor, $A_{\text{adjacent wall}} / A_{\text{total}}$, where the area of the adjacent wall is the total area minus the area over the slab edge at the floor the floor glazing.

In each assembly where choosing one of these approaches in necessary, it has been indicated in the thermal performance results sheets in Appendix B.

4. SUMMARY OF THE THERMAL PERFORMANCE CATALOGUE

4.1 CATALOGUE BREAKDOWN

The catalogue prepared for this guide contains extensive thermal performance information on numerous common details, along with details intended to mitigate thermal bridging, including some emerging technologies and products. This data was calculated using the methodology from 1365-RP (including air films), as summarized in Section 1.2. The catalogue also contains thermal performance information from ASHRAE 1365-RP, along with other details previously analyzed by Morrison Hershfield Ltd. The catalogue is broken into two main sections:

- **Appendix A** contains an overview of the assemblies and interface details. This includes isometric drawings, dimensions and material properties.
- **Appendix B** contains the thermal performance information. This includes clear field, linear and point transmittance values, where applicable, along with overall U-values for the modeled assembly sizes and temperature indices.

The catalogue has been organized first by construction type as follows:

1. Window-wall
2. Conventional Curtain-wall
3. Unitized Curtain-wall
4. High Performance Curtain-wall
5. Steel-Framed Construction
6. Metal Buildings
7. Concrete Construction
8. Woof-Frame and Timber Construction
9. Doors and Balconies
10. Roofs

Within each construction type category the assemblies have been organized by transmittance type. Table 1 summarizes the types of transmittances that are featured in the catalogue. A more detailed discussion on the catalogue information is given at the beginning of Appendices A and B.

Table 4: Transmittance Type Sub-Categories

Detail Type	Detail Sub-Category
Clear Field Assemblies	wall, roof, spandrel section, cladding attachment method, insulation strategy
At-grade Transitions	exposed, exterior insulated, wood
Floor and Balcony Slab Transitions	exposed, under-insulated, shelf angle, manufactured thermal break, exterior insulated, wood
Glazing Transitions	un-insulated, misaligned insulation, efficiently aligned
Interior Wall Intersections	exposed, exterior insulated
Corners	interior insulated, exterior insulated
Parapets	exposed, under-insulated, manufactured thermal break, exterior insulated, wood
Roofs	penetrations, transitions
Structural Beams	through beam, manufactured thermal break

Many projects have architectural packages that can contain an overwhelming number of details (150+), and accounting for every interface detail can be time consuming and impractical. An intent of providing a catalogue is that by becoming familiar with the assemblies and interface details included here, designers will be able to estimate when interface details will have an impact on the building envelope and when similar details can be grouped together. As with any estimating process, good judgment will always be required.

4.2 THERMAL PERFORMANCE CATEGORIES

Previous work has been done (Janssens et al. 2007, BETB Guide V1 2014) to categorize thermal transmittances to help designers compare details and set expectations for details that have not been explicitly modeled. Previous versions of the BETB Guide categorized thermal bridges as “efficient” based on what was considered good for industry practice circa 2010. These categories were revisited in light of what level of thermal bridging mitigation is required to meet low TEDI and net-zero ready standards as outlined in the Low TEDI Guide (Morrison Hershfield Ltd., 2018).

Establishing expectations and categories for thermal transmittances has several uses:





1. Not every common interface detail has been evaluated with publically readily available data. Ranges help with estimating the order of magnitude of transmittance values for interface details that are not directly covered by the BETB catalogue, without the need for further evaluation.
2. Some project specific interface details will still require further evaluation. The ranges for transmittances help set expectations for evaluating other interface details.
3. Ratings can establish default assumptions and/or set prescriptive requirements for the inclusion of interface details in codes and energy standards.
4. Similarly, ratings can establish values for the baseline buildings of the performance compliance paths in energy standards and/or performance rating programs (for example LEED).

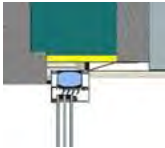

5. Ranges for interface details can help set thermal performance targets for the building envelope early in design. When included with a preliminary energy model (before details are even chosen) the ranges can show what can be expected from the building envelope based on a given construction type.

4.2.1 PERFORMANCE CATEGORIES FOR LINEAR TRANSMITTANCES

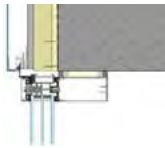
All the linear transmittances in the BETB catalogue have been assigned a category, from poor to thermal bridge free, based on the thermal transmittance ranges outlined in Table 2.

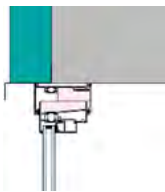
Table 2: Performance Categories and Default Linear Transmittances

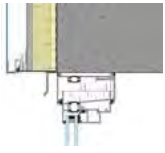
Performance Category	Linear Transmittance		Description and Examples	
	$\frac{\text{Btu}}{\text{hr ft F}}$	$\frac{\text{W}}{\text{m K}}$		
Thermal Bridge Free	<0.006	<0.01		Fully exterior insulated and fully aligned thermal insulation between components Examples: exterior insulated walls at intermediate floors.
				Well aligned glazing without conductive bypasses and minimal thermal bridging in clear wall Examples: wall insulation is aligned with the glazing thermal break and insulation is provided around the perimeter of the window framing. Flashing does not bypass the thermal break. Low conductive window frames and/or insulation outboard of the window frame.
Efficient	0.058	0.1		Fully insulated with only small conductive bypasses Examples: split insulated wall at intermediate floor, exterior insulated walls at intermediate floors with additional cladding attachment at floor.
				Well aligned glazing without conductive bypasses Examples: wall insulation is aligned with the glazing thermal break. Flashing does not bypass the thermal break.
Mitigated	0.12	0.2		Thermally broken connections with good alignment of adjacent thermal insulation Examples: large structural thermal breaks where the thickness of the thermal break is similar in size as the thermal insulation.
				Well aligned glazing with minimal conductive bypasses Examples: the glazing thermal break is within the wall insulation, but there is thermal bridging related to conductive window frames, flashing partially bypasses the exterior insulation, and un-insulated window perimeters.

Performance Category	Linear Transmittance		Description and Examples	
	$\frac{\text{Btu}}{\text{hr ft F}}$	$\frac{\text{W}}{\text{m K}}$		
Moderate	0.17	0.3		Thermally broken and intermittent structural connections Examples: structural thermal breaks where the insulation and break do not have similar thickness or thermal resistance, and stand-off shelf angles.
				Misaligned glazing and minor conductive bypasses Examples: wall insulation is not aligned with the window thermal break and the exterior insulation is completely bypassed by flashing or a metal closure.
Regular - Poor	>0.17	>0.3		Un-insulated, continuous structural connections, and major conductive bypasses Examples: un-insulated balconies, exposed concrete floor slabs, and shelf angles attached directly to the edge of the floor.
				Un-insulated and conductive bypasses Examples: metal closures connected to structural framing. Un-insulated concrete opening (wall insulation does not extend into the window opening).

4.2.2 PERFORMANCE CATEGORIES FOR POINT TRANSMITTANCES

The impact of point thermal bridges depends on the spacing between, or density (number of components per area) of, the component that bypasses the thermal insulation. Point transmittances can be utilized for components that do not have a large cross-sectional area but are closely spaced together, such as fasteners, or for components that have a large cross section area but are not spaced far apart, such as beams. The impact each thermal bridge has on the overall thermal transmittance depends on the point transmittance multiplied by the density of the component.

Recognizing that many closely spaced components with low point transmittances can have the same impact as a large beam with a higher point transmittance leads to different expectations for the thermal quality of point transmittances, based on the component density. Performance categories for point transmittances can be divided into two based on the component density as:

Class 1 – Closely Spaced Point Thermal Bridges

Class 2 – Dispersed Point Thermal Bridges

The component density, examples, and performance for each category follow below.

PERFORMANCE CATEGORIES FOR CLOSELY SPACED POINT THERMAL BRIDGES – CLASS 1

Fasteners through continuous insulation and brackets, ties, and clips for cladding attachment systems where the density of the structural element is greater than 2 per square meter (0.185 per ft²) are in this category.

For example, a bracket that is part of a cladding attachment system that is spaced at 406 mm (16”) o.c. horizontally and 609 mm (24”) o.c. vertically has a density of 4 brackets per m² [1 bracket/(0.406*0.609)]. Fasteners for mechanically attached conventional roof assemblies have fastener densities in the order of magnitude of 3 to 7 fasteners/m² (0.25 to 0.65 fasteners/ft²).

Thermal transmittance ranges for closely spaced point transmittances are outlined in Table 3.

Table 3: Performance Categories and Default Point Transmittances for Closely Spaced Point Thermal Bridges

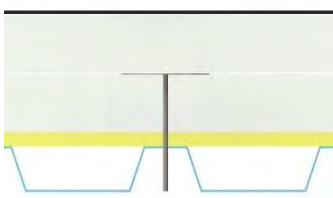
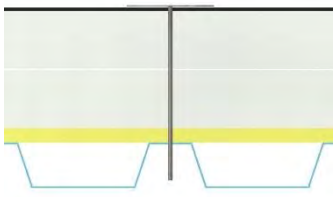
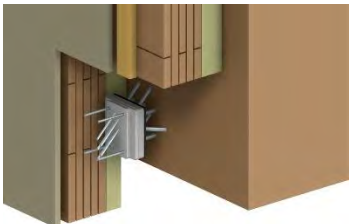
Performance Category	Point Transmittance		Description and Examples	
	$\frac{\text{Btu}}{\text{hr F}}$	$\frac{\text{W}}{\text{K}}$		
Thermal Bridge Free	<0.004	<0.0025		Fasteners that are exterior insulated Example: fasteners that do not penetrate all the insulation layers in a conventional low slope roof assemblies.
Efficient	0.026	0.015		Brick ties or brackets with thermal bridging mitigation and moderate conductivity, fasteners that penetrate the entire insulation Examples: fully mechanically attached conventional low slope roof assemblies, stainless steel brick ties and brackets, thermally broken steel components
Mitigated	0.09	0.05		Thermally broken aluminum components and concrete penetrations Examples: aluminum brackets and support with thermal breaks, concrete embedment with insulated perimeter

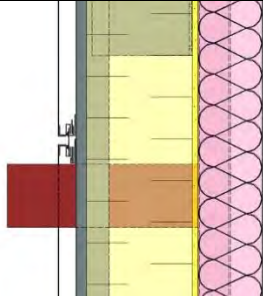
Performance Category	Point Transmittance		Description and Examples
	$\frac{\text{Btu}}{\text{hr F}}$	$\frac{\text{W}}{\text{K}}$	
Regular - Poor	>0.09	>0.05	 <p>Unmitigated metal penetrations Examples: steel knife edges</p>

PERFORMANCE CATEGORIES FOR DISPERSED POINT THERMAL BRIDGES – CLASS 2

Beams, anchors, columns, and other structural elements that have a density less than 2 per square meter (0.185 per ft²) are in this category. For example, a beam that is located at every floor at every floor with 3 m (10') floor height and 0.9 (3') horizontal spacing has a density less than 1 beam per m².

Thermal transmittance ranges for dispersed point transmittances are outlined in Table 4.

Table 4: Performance Categories and Default Point Transmittances for Dispersed Point Thermal Bridges

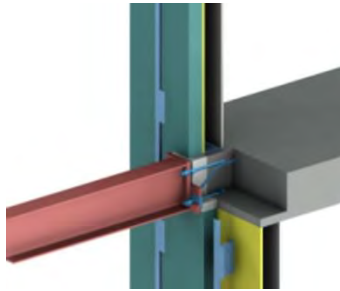
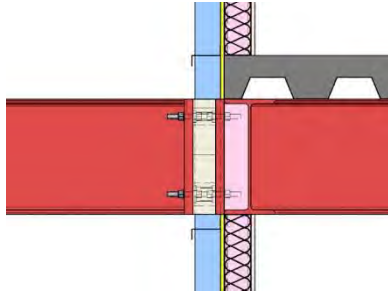
Performance Category	Point Transmittance		Description and Examples
	$\frac{\text{Btu}}{\text{hr F}}$	$\frac{\text{W}}{\text{K}}$	
Efficient	0.17	0.01	 <p>Thermal break thickness is similar to the insulation thickness and the supporting structure is not steel Examples: manufactured thermal break for a beam penetration at a concrete intermediate floor or a roof anchor on a concrete deck</p>
Mitigated	0.43	0.25	 <p>Thermal break thickness is similar to the insulation thickness and the supporting structure is steel Examples: manufactured thermal break for a beam penetration at a steel intermediate floor</p>

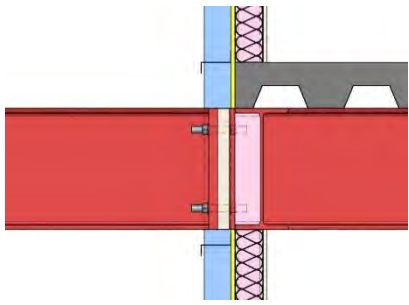
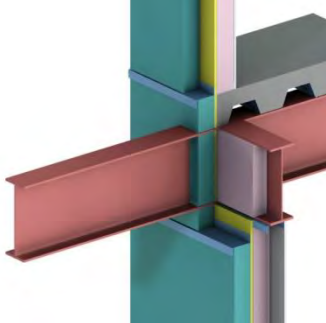
Performance Category	Point Transmittance		Description and Examples
	$\frac{\text{Btu}}{\text{hr F}}$	$\frac{\text{W}}{\text{K}}$	
Moderate	0.86	0.5	 <p>Thermally isolated penetrations with pads equal or greater than 50 mm (2”) and stainless-steel bolts, Insulation wrap around penetration that extends outward more than 762 mm (2.5 feet) Examples: pad for beam penetration with stainless steel bolt connection, insulation extending down a concrete column of an insulated floor</p>
Regular - Poor	>0.86	>0.5	 <p>Minimal thermal isolation and uninterrupted large penetrations Examples: thin pads or beam penetrations with steel bolted connections</p>

4.3 OTHER SOURCES OF INFORMATION

While the catalogue provided with this guide is extensive, there are additional sources to find thermal performance data for clear field assemblies and linear and point transmittances. Here are a few examples:

- Appendix A of **ASHRAE 90.1 “Energy Standard for Buildings Except Low-Rise Residential”** (ASHRAE, 2010) contains several tables of thermal performance values for a variety of clear field constructions, including walls, roofs and floors for concrete, steel framed and wood framed constructions. The values for many of the exterior insulated structures assume continuous insulation and do not account for cladding attachments which interrupt the exterior insulation.
- **Manufacturers of proprietary systems**, such as structural cladding attachments or curtain-wall systems, often have thermal performance data of their products. Upon request they can provide designers with the information. However, be aware that different manufacturers may calculate thermal performance using various procedures, sometimes making it difficult to compare different systems appropriately. If the manufacturer does not provide a full report on their thermal performance values, it may be prudent to request further information.

- In the absence of more specific information, **ISO 14683:2007 “Thermal Bridges in Building Construction”** (CEN, 2007) provides generic linear transmittances for simplified constructions. This standard outlines the methods of calculating linear transmission used in the European standards and provides an Annex with default Ψ values for many of the common interface details. The default values are based on very basic geometric shapes representing building components, as shown in Figures 10 and 11, resulting in conservative transmittance values. For example, complex heat flow paths created by misaligned glazing thermal breaks or flashing are not captured by these values. This standard also provides multiple linear transmittances based on different dimensioning procedures. See the breakout box “A Note on Linear Length and Area Takeoffs for the Detail Oriented” in section 3.4.1 for more information.

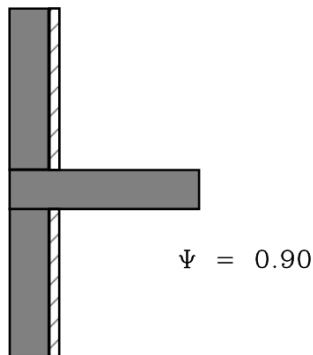

Figure 10: A reproduction of a simplified concrete wall assembly with interior insulation at through wall slab from ISO 14683:2007

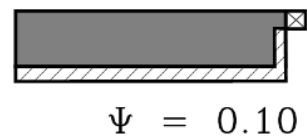

Figure 11: A reproduction of a simplified concrete wall assembly at a window jamb from ISO 14683:2007

5. EXAMPLE UTILIZATION OF THE CATALOGUE

In order to demonstrate how to utilize the catalogue in calculating overall U-values for a building, the following is a step-by-step example for a common Vancouver residential high-rise building.

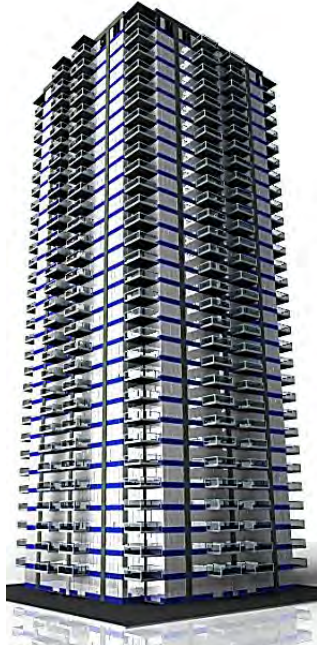

Figure 0.1: Example High-Rise MURB with 60% glazing

Example: A designer wishes to find the overall U-value for each construction type for a High-Rise Multi-unit Residential Building with 60% glazing.

The building (illustrated in Figure 1.11) is concrete construction, with an R-11 (RSI-1.94) interior insulated concrete wall between window-wall sections. The window-wall sections include a glazed section (U-0.4, USI-2.3) and spandrel section with R-8.4 (RSI-1.48) insulated backpan. The roof contains an R-20 (RSI-3.52) insulated deck that has several beam penetrations and curbs to support an architectural feature. There are balconies, exposed concrete slab edges and window-wall bypasses. All details are typical and assumed to be contained within an architectural drawing package.

Step 1: Determine How to Divide Up the Building

In calculating building envelope U-values, first it should be known how the U-values will be used. U-values can be calculated for different areas depending on how the U-value will be utilized or level of detail required. For example, the building envelope performance could be divided by zone to find specific zone heating loads, by construction type for whole building energy analysis or kept as one value for the whole building for preliminary design. The methodology to find the different U-values are the same and it is up to the judgment of the designer on what they require.

In this example, the designer chooses to divide the building by construction type.

Step 2: Determine Clear Field Assemblies

The construction types can be determined through the clear field assemblies, which can be found from wall/roof/floor schedules, as shown in Figure 13, but also by sorting through the elevations and detail drawings. There may be multiple clear field assemblies for a single construction type (i.e. several steel stud assemblies), but if they are similar enough in thermal transmittance, with good judgment they can be combined and considered one assembly.

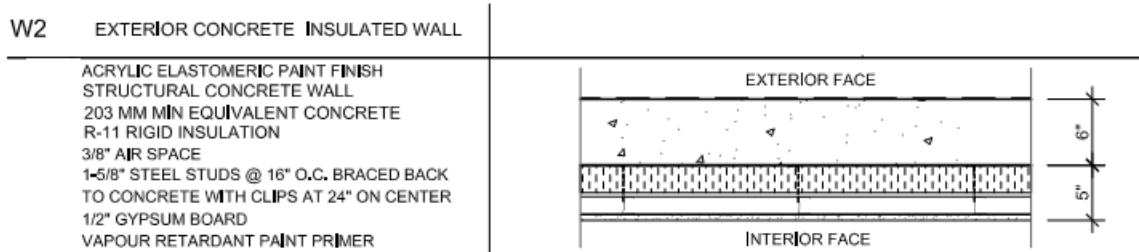

Figure 13: Example concrete clear field wall assembly

For this example, from the architectural drawings, the designer finds there are three distinct construction types in the wall and roof schedules: Concrete Wall, Concrete Roof and Window-wall Spandrel.

Step 3: Determine Linear and Point Details

After determining the clear field assemblies, the types of linear and point details need to be found. In architectural drawings, these can be found through elevations, plans and detail drawings, as shown in Figures 14 and 15.

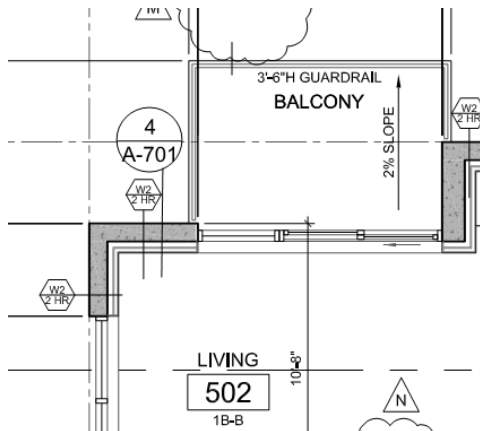

Figure 14: Exposed Floor Slab in Plan 4/A701

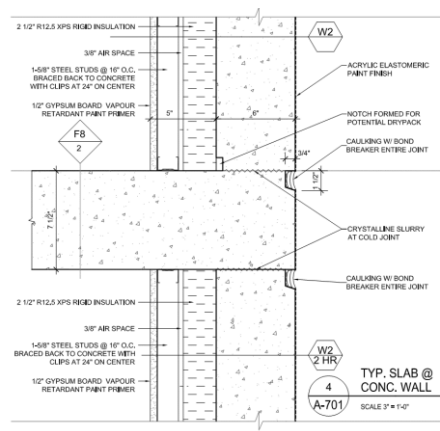

Figure 15: Exposed Floor Slab detail 4/A701

When dividing by construction type, the interface details can also be divided in the same way and can be assigned to specific clear field assemblies. For each clear field assembly there will be a set of linear and/or point details associated with it. For transitions between different clear field assemblies (such as a parapet transition between wall and roof) it is up to the designer to choose which assembly to assign the heat loss to.

For this example, an isometric floor plan is given in Figure 16. From the architectural drawings, the designer determines there are several standard details and assigns them to the concrete wall, the window-wall spandrel or the roof. In this case, the designer assigns the parapets to the walls.



In the drawings, the designer finds there are only balcony slabs at the spandrel sections. The transmittance types are summarized in Table 3. For the simplicity of this example, other miscellaneous details have been omitted.

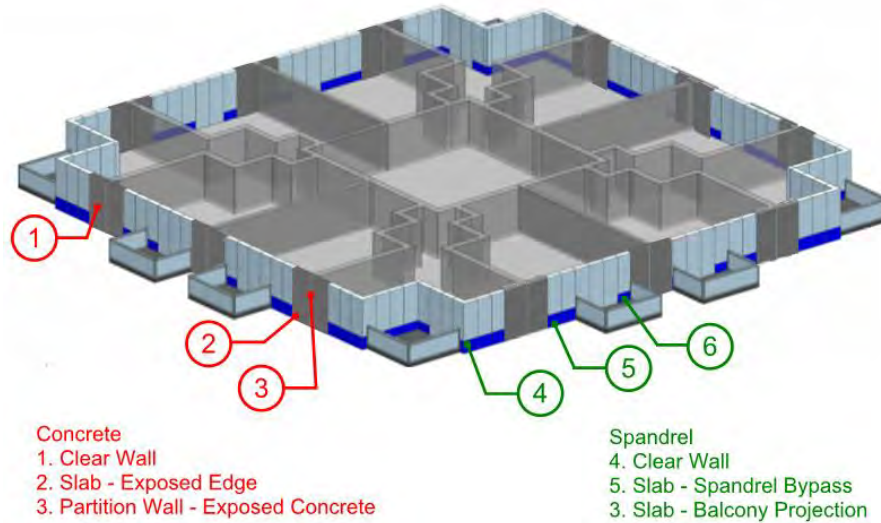

Figure 16: Example building typical floor plan

Table 3: Summary of Steps 1-3 for example building

Step 1-2	Step 3
Transmittance Type	
Concrete Wall	Clear Field – Concrete Wall
	Parapet – Exposed Concrete
	Slab - Exposed Concrete Edge
	Slab - At Grade Transition
	Partition Wall - Exposed Concrete
Window-wall Spandrel	Clear Field – Spandrel
	Parapet – Partially insulated by Spandrel
	Slab – Spandrel Bypass
	Slab – Spandrel with Balcony projection
	Slab - At Grade Transition
Roof	Clear Field – Roof
	Curb – Uninsulated
	Point Penetrations – Structural Beams

Step 4: Determine Area and Length Takeoffs

With the types of transmittances (clear field, linear and point) found, the area, lengths and number of instances should be determined. Information on takeoffs is given in section 3.4.1. Areas for the clear field can typically be easiest to determine from elevation drawings. Lengths for slabs, parapets and other horizontal linear details can be found through plans, while lengths for vertical linear details (such as corners) can be found in the elevations. An example takeoff for slab edges is shown in Figure 17.

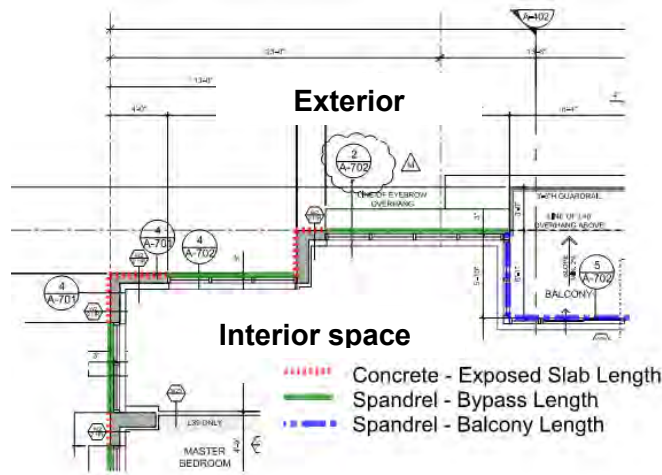

Figure 17: Example slab length takeoff

Using the floor plans and elevations, the designer determines the appropriate takeoffs for each detail they determined in Table 3. Using the elevations, the areas of the clear fields (including areas over the slab edges) are found. The slab edge lengths for a single floor are calculated, and then are multiplied by the amount of similar floors in the building. Each of the partition walls are found to extend the height of the building. The parapet lengths and curb lengths and number of beam penetrations are found using the roof plan and the at-grade transitions are found using the ground floor plan. Takeoff areas and lengths for this example are given in Table 4.

Step 5: Determine Clear Field, Linear and Point Transmittances

Thermal performance data for clear field, linear and point details can be found in the catalogue provided with this guide, or through other sources (outlined in section 4.3). The project specific interface details can be matched up with the catalogue details in Appendix A and the thermal values are given in Appendix B. If a specific project detail cannot be found in the catalogue, judgment will be required to estimate the thermal performance by comparing similar details or by using the ranges in section 4.2. If that cannot be done with certainty, then further modeling may be necessary.

For this example, the designer matches as many clear field assemblies and interface details to the catalogue as they can. The designer first reviews the database summary at thermalenvelope.ca, then narrows down to the specific details. The designer finds the following:

- For the concrete wall clear field and interface details, the designer finds appropriate matching details in Appendix A.6 – Mass Walls and the thermal values for those details in Appendix B.6, except for the at-grade transition.
- The designer finds an appropriate linear transmittance for the concrete at-grade transition in ISO 14863.

- For the spandrel wall clear field and interface details, the designer finds appropriate matching details in Appendix A.1 – Window-wall and Appendix A.8 – Balconies and Doors, along with the thermal data in Appendix B.1 and B.8, except for the at-grade transition.
- The designer estimates the at-grade transition by comparing their project detail to a similar conventional curtain-wall Detail 2.5.1.
- The designer finds matching roof details in Appendix A.9 – Roofs along with the matching thermal data in Appendix B.9.
- The designer decides not enough information is available to estimate the roof penetrations and decides to have that detail modeled.

Detail references and transmittances for this example are given in Table 4.

Step 6 (Optional): Calculate Individual Transmittance Heat Flow

While not necessary to calculate the overall U-value, it may be advantageous for designers to calculate the individual heat flows associated with specific details to help make better design decisions and identify details that should be targeted. Recognizing components of the U-value equation given in section 3.4, the individual heat flows can be calculated using the following:

- Clear Field Heat Flow = $U_o \cdot A$
- Linear Transmittance Heat Flow = $\Psi \cdot L$
- Point Transmittance Heat Flow = $\chi \cdot \text{number of occurrences}$

For this example, the designer calculates the heat flow through the individual details to see which interface details have the largest impact on thermal performance. From that analysis the designer is able to determine which details should be a priority to improve. Individual heat flows for this example are given in Table 4.

Step 7: Calculate Overall U-Value

With all the transmittance values and takeoff areas/lengths known, the overall Wall/Roof U-values can be calculated using the equation given in section 3.4.

$$U_T = \frac{\Sigma(\Psi \cdot L) + \Sigma(\chi)}{A_{Total}} + U_o$$

If the individual heat flows have already been determined in Step 6, then all of the heat flows can be summed together and divided by the total opaque area (in this case, the clear field area) to get the overall U-value that includes the effects of thermal bridging at interface details.

The designer calculates the overall U-values for each construction type, along with an overall Opaque Wall U-value and Opaque Roof U-value separately. The summary of all steps for the example building is given in Table 4 and 5 for the walls and roof respectively.

Table 4: Summary of Calculation Steps 1-7 for Example Building Opaque Wall

Step 1-2	Step 3	Step 4	Step 5		Step 6-7	
Transmittance Type		Quantity	Detail Ref.	Transmittance	Heat Flow (W/K)	% of Total Heat Flow
Concrete Wall	Clear Field	2987 m ²	6.2.2	0.42 W/m ² K	1254	16%
	Parapet	27 m	6.5.3	0.78 W/mK	21	<1%
	Exposed Floor Slab	1090 m	6.2.5	1.00 W/mK	1085	14%
	At Grade Transition	27 m	ISO-14863	0.75 W/mK	20	<1%
	Partition Wall	1315 m	6.2.2	0.67 W/mK	876	11%
Overall Concrete Wall U-value, BTU / hr ft ² °F (W/m ² K)					0.192 (1.09)	
Overall Concrete Wall R-value, hr ft ² °F/ BTU (m ² K/W)					5.2 (0.92)	
Window-wall Spandrel	Clear Field	1792 m ²	1.1.1	1.07 W/m ² K	1917	24%
	Parapet	82 m	1.3.2	0.72 W/mK	59	<1%
	Slab Bypass	1635 m	1.2.1	0.58 W/mK	945	12%
	Balcony Slab	1635 m	8.1.9	1.11 W/mK	1815	23%
	At Grade Transition	82 m	2.5.1 (est.)	0.86 W/mK	70	<1%
Overall Spandrel Wall U-value, BTU / hr ft ² °F (W/m ² K)					0.472 (2.68)	
Overall Spandrel Wall R-value, hr ft ² °F/ BTU (m ² K/W)					2.11 (0.37)	
Total (W/K)					8063	100%
Overall Opaque Wall U-value, BTU / hr ft² °F (W/m²K)					0.297 (1.68)	
Overall Opaque Wall R-value, hr ft² °F/ BTU (m²K/W)					3.4 (0.59)	

Table 5: Summary of Calculation Steps 1-7 for Example Building Opaque Roof

Transmittance Type		Quantity	Detail Ref.	Transmittance	Heat Flow (W/K)	% of Total Heat Flow
Roof	Clear Field	743 m ²	9.2.2	0.27 W/m ² K	200	82%
	Curbs	20 m	9.2.2	0.93 W/m K	19	8%
	Beam Penetrations	#20	Modelled	1.2 W/K	24	10%
Overall Roof U-value, BTU / hr ft ² °F (W/m ² K)					0.058 (0.33)	
Overall Roof R-value, hr ft ² °F/ BTU (m ² K/W)					17.3 (3.05)	

Even though it takes up less area of opaque wall than the concrete, the designer can see that the largest amount of heat flow is associated with the spandrel section clear field, but the heat flow through the window-wall bypass and the balconies is also significant.

6. INPUTTING THERMAL VALUES INTO ENERGY MODELS

Determining overall building performance, including the combined interaction between envelope, mechanical and electrical systems, is often termed “whole building energy analysis” and is often assessed using computer simulation and is used for multiple purposes, including:

- Design decision making through parametric analysis, by considering the energy and cost impact of design decisions to reduce energy or meet code
- Demonstrating compliance with energy codes
- Comparing a proposed building to a reference building for green building rating systems (LEED, Green Globes, etc.)
- Estimating energy use in new or existing buildings
- Estimating the impact of operational improvements or capital investments in existing buildings
- Heat loss calculations for mechanical system sizing

One of the main drivers for creating this guide was to provide more accurate thermal values and a methodology for designers to assist in creating more precise energy models.

Currently, there are few energy modeling programs that allow linear transmittance values to be input directly into energy simulations. While this feature is being considered for development for common building energy simulation software, at the moment this ability is not widely available. Thermal transmittances are either directly inputted as wall, roof or floor U-values or determined by using construction layers to build up the building envelope assemblies. For either case, the overall U-value that includes the effects of linear and points transmittances must first be determined without the assistance of the energy modeling software to ensure that the correct thermal transmittances will be processed by the model.

It is important to emphasize that air leakage and dynamic thermal responses are accounted for by separate functions in typical whole building energy models. Thermal bridging is accounted for only in the thermal transmittances that are processed by the energy model. See Appendix C for an explanation of how energy models take into account thermal mass separately from thermal transmittances.

Many modeling programs use construction layers to build up the building envelope assemblies based on material properties. To account for thermal bridging, all the material properties should be left as is, while only the insulating layer R-value should be de-rated such that the correct overall U-value determined from calculation is matched and output by the software. This method allows for the functions that account for thermal mass to be approximated by the software.

Example: *a section of concrete wall with R-15 exterior insulation contains a balcony slab and is calculated to have an overall U-value of U-0.16. The energy modeling program being used requires construction layers as the inputs. The layers are input with default values for the air films, cladding, airspaces, concrete and interior finishes and the simulation output shows a U-value of U-0.05. The exterior insulation R-value is edited and decreased from R-15 such that in the simulation output, the U-value for the overall wall assembly matches U-0.16.*

One final note on model inputs, the clear field U-values given in the thermal performance catalogue in this guide are based on the ASHRAE 1365-RP methodology, which include air films. Many energy modeling programs calculate air films separately. The air films for the modeled details in this guide are listed with the material properties in each of the details in Appendix A. The thermal resistance of these air films may need to be subtracted out before entering R- or U-values into an energy modeling program.

7. REFERENCES

- ASHRAE. (2010). *ASHRAE 90.1 Energy Standard for Buildings Except Low-Rise Residential Buildings*. Atlanta, GA: American Society of Heating, Refrigerating and Air-Conditioning Engineers Inc.
- ASHRAE. (2013). *Handbook of Fundamentals*. Atlanta, GA: American Society of Heating, Refrigerating and Air-Conditioning Engineers Inc.
- CEN. (2007). *ISO 14683 Thermal bridges in building construction - Linear thermal transmittance - Simplified methods and default values*. Brussels: European Committee for Standardization.
- Janssens, A., Van Londersele, E., Vandermarcke, B., Roels, S., Standaert, P., Wouters, P., & A, A. (2007). Development of Limits for the Linear Thermal Transmittances of Thermal Bridges in Buildings. *Thermal Performance of the Exterior Envelopes of Whole Buildings X International Conference* (p. Paper 182). Atlanta, GA: American Society of Heating, Refrigerating and Air-Conditioning Engineers.
- Mitchell, R., Kohler, C., Curcija, D., Zhu, L., Vidanovic, S., Czarnecki, S., . . . Huizenga, C. (Rev 2013). *THERM 6.3/WINDOW 6.3 NFRC Simulation Manual*. Berkeley: University of California.
- Morrison Hershfield Ltd. (2011). *ASHRAE 1365-RP Thermal Performance of Building Envelope Construction Details for Mid- and High-Rise Buildings*. Atlanta, GA: American Society of Heating, Refrigerations and Air-Conditioning Engineers Inc.
- Morrison Hershfield Ltd. (2018). *Guide to Low Thermal Energy Demand for Large Buildings*. Vancouver, BC: BC Housing.

APPENDIX A – CATALOGUE MATERIAL DATA SHEETS

CATALOGUE INDEX

Introduction	A.0.i
1.0 Window Wall	A.1.i
2.0 Conventional Curtain Wall	A.2.i
3.0 Unitized Curtain Wall	A.3.i
4.0 High Performance Curtain Wall	A.4.i
5.0 Steel-Frame Construction	A.5.i
6.0 Metal Buildings	A.6.i
7.0 Concrete and Mass Masonry Construction	A.7.i
8.0 Wood-Frame and Timber Construction	A.8.i
9.0 Doors and Balconies	A.9.i
10.0 Roofs	A.10.i

Introduction

Introduction

Appendix A contains the catalogue of material data information sheets for all the details available for this guide. The purpose is to provide this information such that designers will be able to easily reference their project details to a modeled detail within the catalogue or to be able to make estimations based on the information provided. The catalogue is divided into 10 sections, based on construction type:

Catalogue Index	
1.	Window Wall
2.	Conventional Curtain Wall
3.	Unitized Curtain Wall
4.	High Performance Curtain Wall
5.	Steel-Framed Construction
6.	Metal Buildings
7.	Concrete and Mass Masonry Construction
8.	Wood-Frame and Timber Construction
9.	Balconies and Doors
10.	Roofs

Within each section contains a variety of clear field and interface details. The catalogue contains details modeled by Morrison Hershfield Ltd. for this guide, along with previous modeling, including ASHRAE 1365-RP and other proprietary systems.

Each material data sheet is meant to be standalone and contains all the information needed for that particular detail. For instance, Detail 5.2.5 is a balcony slab detail for a steel stud assembly. That data sheet contains the material information for both the slab detail, and the clear field steel stud assembly above and below it. The clear field steel stud assembly material data sheet 5.1.14 is not additionally required to analyze the slab detail.

It should be noted that, as they are standalone, there are not necessarily a matching clear field data sheet for every detail. Additionally, some assemblies shown in the data sheets contain more than one interface detail, so while they are arranged by major detail type (slab, then parapet etc), there may be other interface details contained within it. The thermal results information in each results data sheet in Appendix B is given for all interface details contained within a single assembly detail.

Air Films and Contact Resistances

In thermal modeling, beyond the assembly material properties, assemblies are also affected by air films and contact resistances. From ASHRAE 1365-RP, the modeling was extensively calibrated with air films and contact resistances and is shown below in Tables A.1 and A.2. More information on assumptions and other modeling parameters can be found in Section 5 of ASHRAE 1365-RP.

Table A.1. Air film resistances

Location	Description of Condition	Heat Transfer Coefficient Btu/h-ft ² ·°F (W/m ² ·K)
Exterior wall surface with generic cladding	Heat transfer coefficient to account for vented air space and cladding; surface is not directly exposed to wind	1.5 (8.3)
Exterior brick veneer and Precast Concrete surface	Surface exposed to 15 mph (24 km/h) wind	6.0 (34)
Exterior roof surface	Horizontal roof surface exposed to 15 mph (24 km/h) wind	6.0 (34)
Interior wall surface	Vertical surface exposed to indoor air and surfaces	1.5 (8.3)
Interior ceiling surface	Horizontal surface exposed to indoor air and surfaces with upward heat flow	1.6 (9.3)
Interior floor surface	Horizontal surface exposed to indoor air and surface with downward heat flow	1.1 (6.1)

Table A.2. Contact resistances

Location	Contact Resistance hr-ft ² ·°F /Btu (m ² °C/W)
Steel flanges at sheathing interfaces	0.17 (0.030)
Insulation interfaces	0.057 (0.010)
Steel to concrete interfaces	0.057 (0.010)
Steel to steel interfaces	0.011 (0.0020)

Material Data Sheets

Each material data sheet contains several pieces of information. An example material data sheet is shown below with a description for each section following.

Building Envelope Thermal Bridging Guide

1 **Detail 1.1.1** Window Wall System – Stud Cavity Insulation

2 Panel Clear Wall with No Interior Mullion Detail

ID	Component	Thickness Inches (mm)	Conductivity Btu-in / ft ² ·hr·°F (W/m·K)	Nominal Resistance hr-ft ² ·°F/Btu (m ² ·K/W)	Density lb/ft ³ (kg/m ³)	Specific Heat Btu/lib·°F (J/kg·K)
1	Interior Films (right side) ¹	-	-	R-0.6 (0.12 RSI) to R-1.1 (0.20 RSI)	-	-
2	Wood Sill	1 1/4" (30)	0.69 (0.10)	-	27.8 (445)	0.45 (1880)
3	Steel Sheet Connected to Studs	18 Gauge	430 (62)	-	489 (7830)	0.12 (500)
4	Gypsum Board	1/2" (13)	1.1 (0.16)	R-0.5 (0.08 RSI)	50 (800)	0.26 (1090)
5	Air in Stud Cavity	3 5/8" (92)	-	R-0.9 (0.16 RSI)	0.075 (1.2)	0.24 (1000)
6	1 5/8" x 1 5/8" Steel Stud with Top and Bottom Tracks	18 Gauge	430 (62)	-	489 (7830)	0.12 (500)
7	Aluminum Window Wall Spandrel System with Insulated Backpan: thermally broken frame ²					
8	Backpan Insulation	Varies	-	R-8.4 (1.48 RSI) to R-16.8 (2.96 RSI)	4 (64)	0.20 (850)
9	Aluminum Window Wall Vision System: thermally broken frame, double glazed IGU U _{IGU} =0.31 BTU/hr-ft ² ·°F (1.77 W/m ² ·K) ²					
10	Exterior Film (left side) ¹	-	-	R-0.2 (0.03 RSI)	-	-

¹ Values from table 1, p. 26.1 of 2009 ASHRAE Handbook – Fundamentals depending on surface orientation
² Conductivity of air spaces within framing was found using ISO 100077-2

A. 1.1

1) Detail Name

Each detail is named based on position within the catalogue index. The first number 1.x.x indicates the construction type according to the main index (ie 1 is Window-Wall, 5 is Steel-Framed, 8 is Wood-Framed and Timber, etc). The second number x.1.x indicates detail group (ie. 1 is clear field values, 2 may be all slabs and 3 may be all parapets). The last number x.x.1. is simply the order in which the detail appears within that grouping (ie slab detail 1, slab detail 2 etc).

2) Detail Description

Each material data sheet has a basic description that denotes the construction system or type, along with additional detail identifiers such as limited dimension information, transmittance type and insulation locations

3) Detail Image

An isometric image of each detail is provided that includes cut away sections to view interior portions of the assembly. The images include dimensional information on the modeled assembly, along with ID numbers of key components. Each image is shown from the exterior side.

4) Close Up Image

Some material data sheets also contain close up images for further information on key components in an assembly. These callouts are usually from the same angle as the full assembly, however when an interior feature cannot be seen from that angle, the close up image may indicate it is from an interior view.

5) Material Information

For each component ID number given in the Detail Image, the material data sheets contain a description, thickness, thermal conductivity, nominal resistance (if applicable), material density and specific heat. For full systems that may contain multiple parts, such as window wall, a general description is given. Material properties were taken from standard tabulated values (typically measured at 24°C or 75°F).

6) Additional References

References for the conductivity of air spaces and other information are provided underneath the material tables.

7) PDF Version

With the PDF version of the catalogue, each entry in the catalogue index is linked to each construction section. Within each section, there is an additional index for the details, which are also linked directly to each detail data sheet. To return to the index, simply click on the Building Envelope Thermal Bridging Guide header.

1.0 Window Wall

Detail 1.1.1	A.1.1
Window Wall System – Spandrel Panel Clear Wall with No Interior Stud Cavity Insulation	
Detail 1.1.2	A.1.2
Window Wall System – Spandrel Panel Clear Wall with Interior Spray Foam Insulation	
Detail 1.2.1	A.1.3
Window Wall System – Intermediate Floor Intersection with Spandrel Bypass and no Interior Stud Cavity Insulation	
Detail 1.2.2	A.1.4
Window Wall System – Intermediate Floor Intersection with Spandrel Bypass and Interior Spray Foam Insulation	
Detail 1.2.3	A.1.5
Window Wall System with 3' x 3' Spandrel Section – AIM Applications at Intermediate Floor Intersection	
Detail 1.2.4	A.1.6
Window Wall System – Triple Glazed Insulated Frame at Slab Intersection with Improved Spandrel Bypass & No Interior Stud Cavity Insulation	
Detail 1.2.5	A.1.7
Window Wall System – Full Height Spandrel at Slab Intersection with Spandrel Bypass & No Interior Stud Cavity Insulation	
Detail 1.2.6	A.1.8
Window Wall System – Full Height Spandrel at Slab Intersection with Spandrel Bypass & Interior Spray Foam Insulation	
Detail 1.2.7	A.1.9
Window Wall System – Full Height Insulated Frame at Slab Intersection with Improved Spandrel Bypass & No Interior Stud Cavity Insulation	
Detail 1.2.8	A.1.10
Window Wall System – Full Height Insulated Frame at Slab Intersection with Hybridized Clipped Spandrel & No Interior Stud Cavity Insulation	
Detail 1.2.9	A.1.11
Window Wall System with Upstand Spandrel Section – Intermediate Floor Intersection with Spandrel Bypass and no Interior Stud Cavity Insulation	
Detail 1.2.10	A.1.12
Window Wall System with Full Height Vision Section – Intermediate Floor Intersection with Spandrel Bypass and no Interior Stud Cavity Insulation	
Detail 1.3.1	A.1.13
Window Wall System – Uninsulated Concrete Parapet & Roof Intersection	
Detail 1.3.2	A.1.14

Window Wall System – Partially Insulated Concrete Parapet & Roof Intersection	
Detail 1.4.1	A.1.15
Window Wall System – Inside Corner with Spandrel to Vision Transition & No Interior Stud Cavity Insulation	
Detail 1.4.2	A.1.16
Window Wall System – Inside Corner with Spandrel to Vision Transition & Interior Spray Foam Insulation	
Detail 1.5.1	A.1.17
Window Wall System with Insulated Spandrel Panel – Uninsulated Interior Concrete Wall and Intermediate Floor Intersection	
Detail 1.5.2	A.1.18
Window Wall System with Insulated Spandrel Panel – Insulated Interior Concrete Wall and Intermediate Floor Intersection	

Detail 1.1.1

Window Wall System – Spandrel Panel Clear Wall with No Interior Stud Cavity Insulation

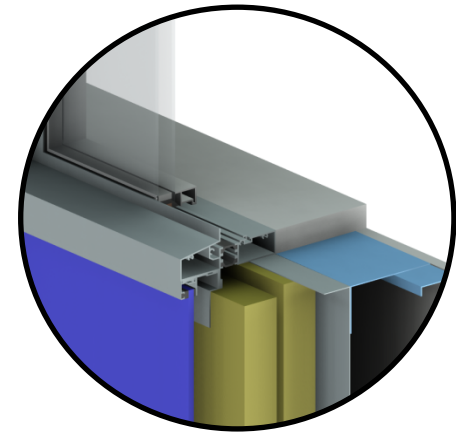
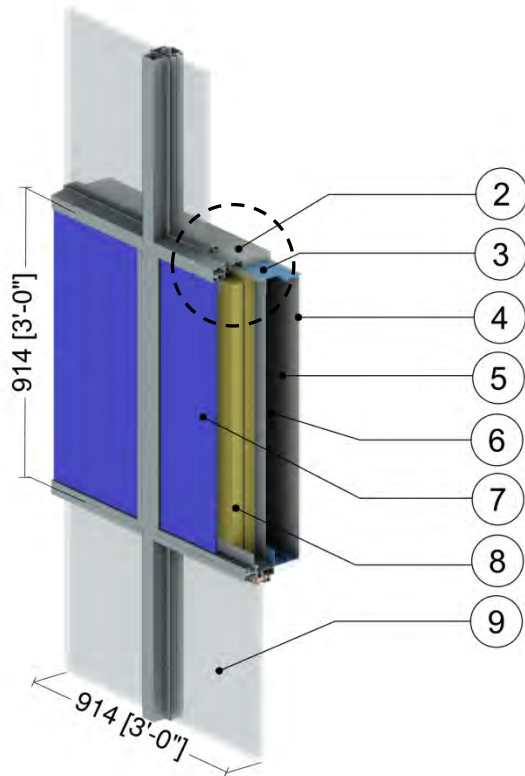

Mullion Detail

ID	Component	Thickness Inches (mm)	Conductivity Btu-in / ft ² ·hr·°F (W/m K)	Nominal Resistance hr·ft ² ·°F/Btu (m ² K/W)	Density lb/ft ³ (kg/m ³)	Specific Heat Btu/lb·°F (J/kg K)
1	Interior Films ¹	-	-	R-0.6 to R-1.1 (0.12 to 0.20 RSI)	-	-
2	Wood Sill	1 1/4" (30)	0.69 (0.10)	-	27.8 (445)	0.45 (1880)
3	Steel Sheet Connected to Studs	18 Gauge	430 (62)	-	489 (7830)	0.12 (500)
4	Gypsum Board	1/2" (13)	1.1 (0.16)	R-0.5 (0.08 RSI)	50 (800)	0.26 (1090)
5	Air in Stud Cavity	3 5/8" (92)	-	R-0.9 (0.16 RSI)	0.075 (1.2)	0.24 (1000)
6	1 5/8" x 1 5/8" Steel Studs (16"o.c.) with Top and Bottom Tracks	18 Gauge	430 (62)	-	489 (7830)	0.12 (500)
7	Aluminum Window Wall Spandrel System with Insulated Backpan: thermally broken frame, no insulation in mullions ²					
8	Backpan Insulation	Varies	0.24 (0.034)	R-8.4 to R-16.8 (1.48 to 2.96 RSI)	4 (64)	0.20 (850)
9	Aluminum Window Wall Vision System: thermally broken frame ² , double glazed IGU U _{COG} = 0.32 BTU/hr·ft ² ·°F (1.82 W/m ² K)					
10	Exterior Film ¹	-	-	R-0.2 (0.03 RSI)	-	-

¹ Value selected from table 1, p. 26.1 of 2009 ASHRAE Handbook – Fundamentals depending on surface orientation

² The thermal conductivity of air spaces within framing was found using ISO 100077-2

Detail 1.1.2

Window Wall System – Spandrel Panel Clear Wall with Interior Spray Foam Insulation

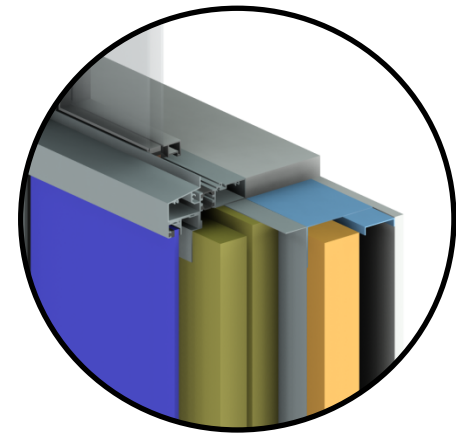
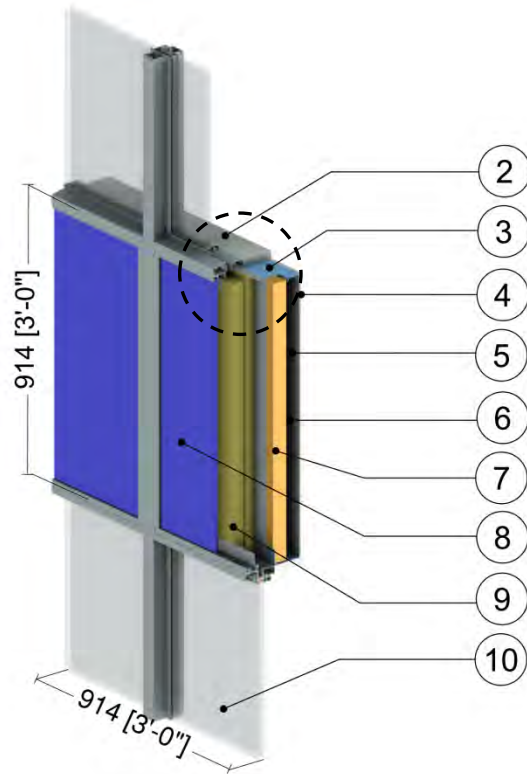

Mullion Detail

ID	Component	Thickness Inches (mm)	Conductivity Btu-in / ft ² -hr-°F (W/m K)	Nominal Resistance hr-ft ² -°F/Btu (m ² K/W)	Density lb/ft ³ (kg/m ³)	Specific Heat Btu/lb-°F (J/kg K)
1	Interior Films ¹	-	-	R-0.6 to R-1.1 (0.12 to 0.20 RSI)	-	-
2	Wood Sill	1 1/4" (30)	0.69 (0.10)	-	27.8 (445)	0.45 (1880)
3	Metal Sheet Connected to Studs	18 Gauge	430 (62)	-	489 (7830)	0.12 (500)
4	Gypsum Board	1/2" (13)	1.1 (0.16)	R-0.5 (0.08 RSI)	50 (800)	0.26 (1090)
5	Air in Stud Cavity	1 5/8" (41)	-	R-0.9 (0.16 RSI)	0.075 (1.2)	0.24 (1000)
6	1 5/8" x 1 5/8" Steel Studs (16" o.c.) with Top and Bottom Tracks	18 Gauge	430 (62)	-	489 (7830)	0.12 (500)
7	Continuous Spray Foam Insulation	2" (51)	0.17 (0.024)	R-12 (2.11 RSI)	2.8 (39)	0.35 (1470)
8	Aluminum Window Wall Spandrel System with Insulated Backpan: thermally broken frame, no insulation in mullions ²					
9	Backpan Insulation	Varies	0.24 (0.034)	R-8.4 to R-16.8 (1.48 to 2.96 RSI)	4 (64)	0.20 (850)
10	Aluminum Window Wall Vision System: thermally broken frame ² , double glazed IGU U _{COG} = 0.32 BTU/hr-ft ² -°F (1.82 W/m ² K)					
11	Exterior Film ¹	-	-	R-0.2 (0.03 RSI)	-	-

¹ Value selected from table 1, p. 26.1 of 2009 ASHRAE Handbook – Fundamentals depending on surface orientation

² The thermal conductivity of air spaces within framing was found using ISO 10077-2

Detail 1.1.3

Window Wall System – Full Height Spandrel with no Interior Stud Cavity Insulation

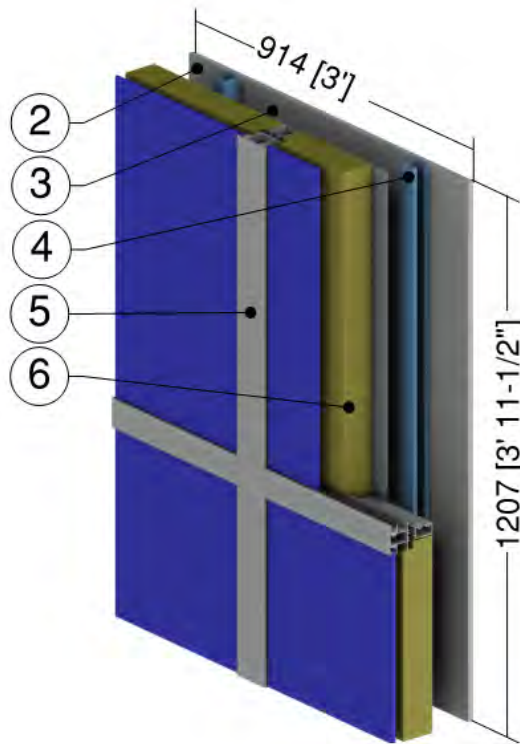

ID	Component	Thickness Inches (mm)	Conductivity Btu·in / ft ² ·hr·°F (W/m K)	Nominal Resistance hr·ft ² ·°F/Btu (m ² K/W)	Density lb/ft ³ (kg/m ³)	Specific Heat Btu/lb·°F (J/kg K)
1	Interior Films ¹	-	-	R-0.7 (0.12 RSI)	-	-
2	Gypsum Board	1/2" (13)	1.1 (0.16)	R-0.5 (0.08 RSI)	50 (800)	0.26 (1090)
3	Air in Stud Cavity	3 5/8" (92)	-	R-0.9 (0.16 RSI)	0.075 (1.2)	0.24 (1000)
4	3 5/8" x 1 5/8" Steel Studs (16"o.c.) with Top and Bottom Tracks	18 Gauge	430 (62)	-	489 (7830)	0.12 (500)
5	Full Height Aluminum Window Wall Spandrel System with Insulated Backpan: thermally broken frame, no insulation in mullions ²					
6	Backpan Insulation	Varies	0.24 (0.034)	R-8.4 to R-16.8 (1.48 RSI to 2.96 RSI)	4 (64)	0.20 (850)
7	Exterior Film ¹	-	-	R-0.2 (0.03 RSI)	-	-

¹ Value selected from table 1, p. 26.1 of 2009 ASHRAE Handbook – Fundamentals depending on surface orientation

² The thermal conductivity of air spaces within framing was found using ISO 100077-2

Detail 1.1.4

Window Wall System – Full Height Spandrel with Interior Spray Foam Insulation

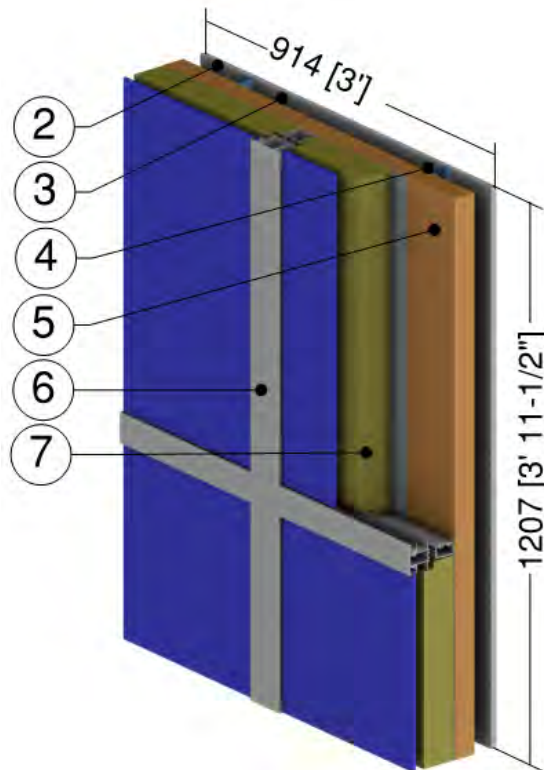

ID	Component	Thickness Inches (mm)	Conductivity Btu·in / ft ² ·hr·°F (W/m K)	Nominal Resistance hr·ft ² ·°F/Btu (m ² K/W)	Density lb/ft ³ (kg/m ³)	Specific Heat Btu/lb·°F (J/kg K)
1	Interior Films ¹	-	-	R-0.7 (0.12 RSI)	-	-
2	Gypsum Board	1/2" (13)	1.1 (0.16)	R-0.5 (0.08 RSI)	50 (800)	0.26 (1090)
3	Air in Stud Cavity	1 5/8" (41)	-	R-0.9 (0.16 RSI)	0.075 (1.2)	0.24 (1000)
4	3 5/8" x 1 5/8" Steel Studs (16"o.c.) with Top and Bottom Tracks	18 Gauge	430 (62)	-	489 (7830)	0.12 (500)
5	Continuous Spray Foam Insulation	2" (51)	0.17 (0.024)	R-12 (2.11 RSI)	2.8 (39)	0.35 (1470)
6	Full Height Aluminum Window Wall Spandrel System with Insulated Backpan: thermally broken frame, no insulation in mullions ²					
7	Backpan Insulation	Varies	0.24 (0.034)	R-8.4 to R-16.8 (1.48 RSI to 2.96 RSI)	4 (64)	0.20 (850)
8	Exterior Film ¹	-	-	R-0.2 (0.03 RSI)	-	-

¹ Value selected from table 1, p. 26.1 of 2009 ASHRAE Handbook – Fundamentals depending on surface orientation

² The thermal conductivity of air spaces within framing was found using ISO 100077-2

Detail 1.2.1

Window Wall System – Intermediate Floor Intersection with Spandrel Bypass and no Interior Stud Cavity Insulation

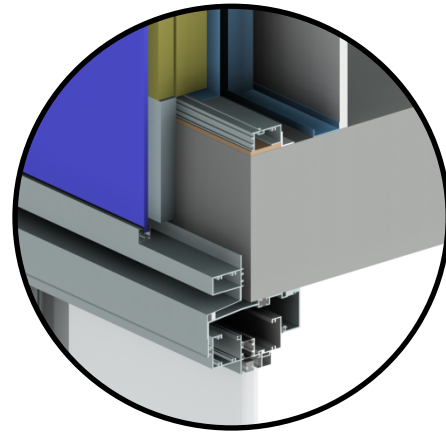
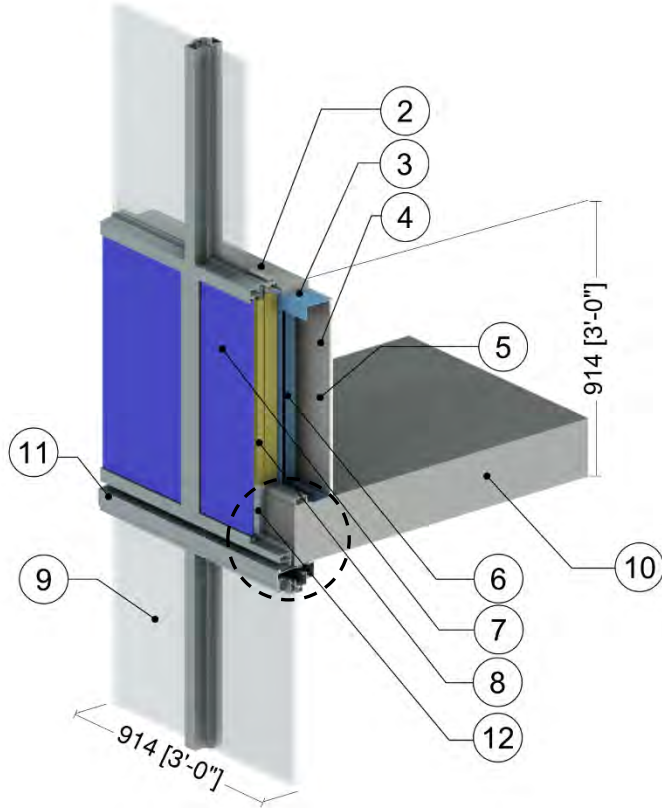

Bypass Detail with Deflection Header and 1/2" (12mm) Air Gap Behind Horizontal Mullion

ID	Component	Thickness Inches (mm)	Conductivity Btu-in / ft ² -hr-°F (W/m K)	Nominal Resistance hr-ft ² -°F/Btu (m ² K/W)	Density lb/ft ³ (kg/m ³)	Specific Heat Btu/lb-°F (J/kg K)
1	Interior Films ¹	-	-	R-0.6 to R-1.1 (0.12 to 0.20 RSI)	-	-
2	Wood Sill	1 1/4" (30)	0.69 (0.10)	-	27.8 (445)	0.45 (1880)
3	Steel Sheet Connected to Studs	18 Gauge	430 (62)	-	489 (7830)	0.12 (500)
4	Gypsum Board	1/2" (13)	1.1 (0.16)	R-0.5 (0.08 RSI)	50 (800)	0.26 (1090)
5	Air in Stud Cavity	3 5/8" (92)	-	R-0.9 (0.16 RSI)	0.075 (1.2)	0.24 (1000)
6	1 5/8" x 1 5/8" Steel Studs (16" o.c.) with Top and Bottom Tracks	18 Gauge	430 (62)	-	489 (7830)	0.12 (500)
7	Aluminum Window Wall Spandrel System with Insulated Backpan: thermally broken frame, no insulation in mullions ²					
8	Backpan Insulation	Varies	0.24 (0.034)	R-8.4 to R-16.8 (1.48 to 2.96 RSI)	4 (64)	0.20 (850)
9	Aluminum Window Wall Vision System: thermally broken frame ² , double glazed IGU U _{COG} = 0.32 BTU/hr-ft ² -°F (1.82 W/m ² K)					
10	Concrete Slab	8" (203)	12.5 (1.8)	-	140 (2250)	0.20 (850)
11	Aluminum Flashing	14 Gauge	1109 (160)	-	171 (2739)	0.21 (900)
12	Bypass Insulation	1" (25)	0.20 (0.029)	R-5 (0.88 RSI)	1.8 (28)	0.29 (1220)
13	Exterior Film ¹	-	-	R-0.2 (0.03 RSI)	-	-

¹ Value selected from table 1, p. 26.1 of 2009 ASHRAE Handbook – Fundamentals depending on surface orientation

² The thermal conductivity of air spaces within framing was found using ISO 100077-2

Detail 1.2.2

Window Wall System – Intermediate Floor Intersection with Spandrel Bypass and Interior Spray Foam Insulation

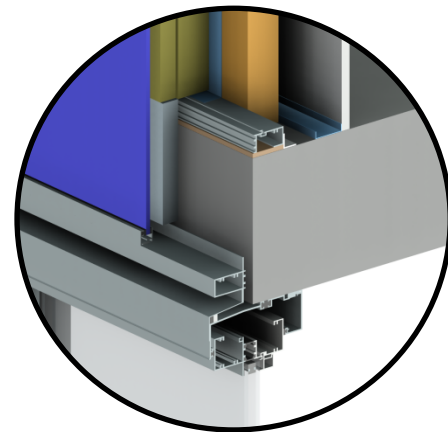
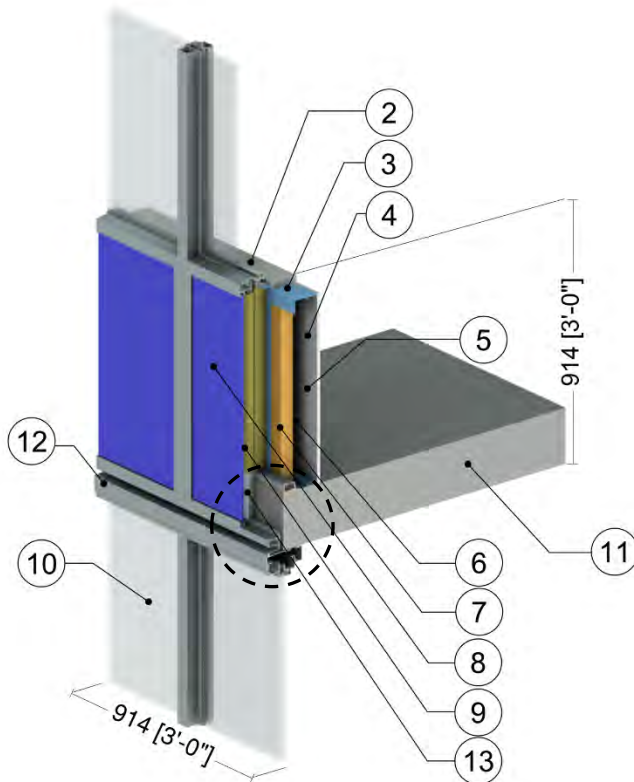

Bypass Detail with Deflection Header and 1/2" (12mm) Air Gap Behind Horizontal Mullion

ID	Component	Thickness Inches (mm)	Conductivity Btu-in / ft ² ·hr·°F (W/m K)	Nominal Resistance hr·ft ² ·°F/Btu (m ² K/W)	Density lb/ft ³ (kg/m ³)	Specific Heat Btu/lb·°F (J/kg K)
1	Interior Films ¹	-	-	R-0.6 to R-1.1 (0.12 to 0.20 RSI)	-	-
2	Wood Sill	1 1/4" (30)	0.69 (0.10)	-	27.8 (445)	0.45 (1880)
3	Steel Sheet Connected to Studs	18 Gauge	430 (62)	-	489 (7830)	0.12 (500)
4	Gypsum Board	1/2" (13)	1.1 (0.16)	R-0.5 (0.08 RSI)	50 (800)	0.26 (1090)
5	Air in Stud Cavity	1 5/8" (41)	-	R-0.9 (0.16 RSI)	0.075 (1.2)	0.24 (1000)
6	1 5/8" x 1 5/8" Steel Studs (16"o.c.) with Top and Bottom Tracks	18 Gauge	430 (62)	-	489 (7830)	0.12 (500)
7	Continuous Spray Foam Insulation	2" (51)	0.17 (0.024)	R-12 (2.11 RSI)	2.8 (39)	0.35 (1470)
8	Aluminum Window Wall Spandrel System with Insulated Backpan: thermally broken frame, no insulation in mullions ²					
9	Backpan Insulation	Varies	0.24 (0.034)	R-8.4 to R-16.8 (1.48 to 2.96 RSI)	4 (64)	0.20 (850)
10	Aluminum Window Wall Vision System: thermally broken frame ² , double glazed IGU U _{COG} = 0.32 BTU/hr·ft ² ·°F (1.82 W/m ² K)					
11	Concrete Slab	8" (203)	12.5 (1.8)	-	140 (2250)	0.20 (850)
12	Aluminum Flashing	14 Gauge	1109 (160)	-	171 (2739)	0.21 (900)
13	Bypass Insulation	1" (25)	0.20 (0.029)	R-5 (0.88 RSI)	1.8 (28)	0.29 (1220)
14	Exterior Film ¹	-	-	R-0.2 (0.03 RSI)	-	-

¹ Value selected from table 1, p. 26.1 of 2009 ASHRAE Handbook – Fundamentals depending on surface orientation

² The thermal conductivity of air spaces within framing was found using ISO 100077-2

Detail 1.2.3

Window Wall System with 3' x 3' Spandrel Section – AIM Applications at Intermediate Floor Intersection

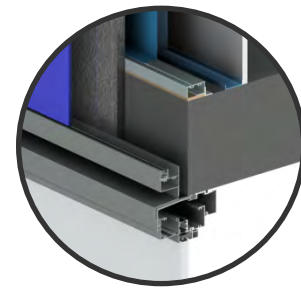
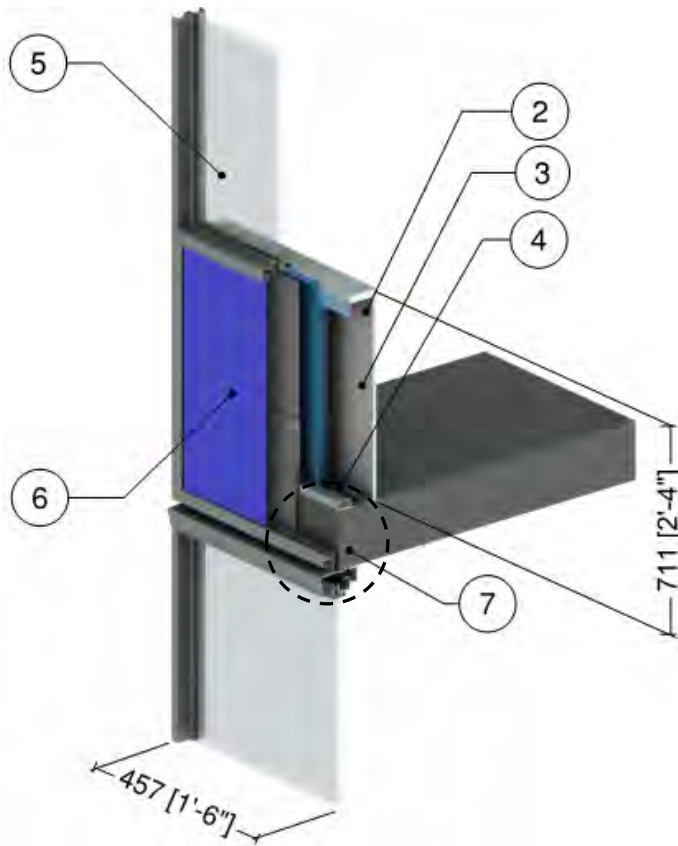

G1 – 3/4" (19 mm) AIM adhered to Frame without Backpan Insulation

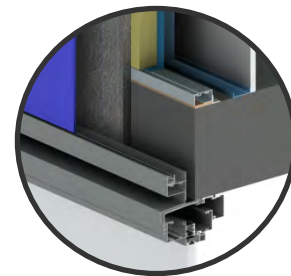

G2 – 3/4" (19 mm) AIM adhered to Frame with 2" (51 mm) Backpan Insulation

ID	Component	Thickness Inches (mm)	Conductivity Btu-in / ft ² -hr-°F (W/m K)	Nominal Resistance hr-ft ² -°F/Btu (m ² K/W)	Density lb/ft ³ (kg/m ³)	Specific Heat Btu/lb-°F (J/kg K)
1	Interior Films ¹	-	-	R-0.6 to R-1.1 (0.12 to 0.20 RSI)	-	-
2	Gypsum Board	1/2" (13)	1.1 (0.16)	R-0.5 (0.08 RSI)	50 (800)	0.26 (1090)
3	Air in Stud Cavity	3 5/8" (92)	-	R-0.9 (0.16 RSI)	0.075 (1.2)	0.24 (1000)
4	1 5/8" x 1 5/8" Steel Studs (16"o.c.) with Top and Bottom Tracks	18 Gauge	430 (62)	-	489 (7830)	0.12 (500)
5	Window Wall Vision Section: double glazed IGU with silicone warm edge spacer ²					
6	Aluminum Window Wall Spandrel Section with varied insulation (see G1 to G2 above) ^{2,3}					
7	Concrete Slab	8" (203)	12.5 (1.8)	-	140 (2250)	0.20 (850)
8	Exterior Film ¹	-	-	R-0.2 (0.03 RSI)	-	-

¹ Value selected from table 1, p. 26.1 of 2009 ASHRAE Handbook – Fundamentals depending on surface orientation

² The thermal conductivity of air spaces within framing was found using ISO 100077-2

³ For a window to wall ratio of 40%

AIM = Architectural Insulation Module

Detail 1.2.4

Window Wall System – Triple Glazed Insulated Frame at Slab Intersection with Improved Spandrel Bypass & No Interior Stud Cavity Insulation

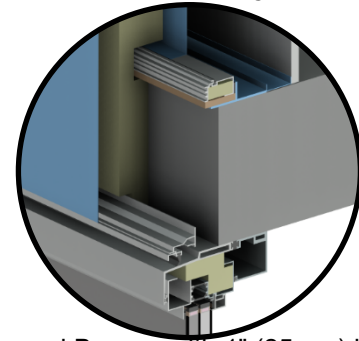
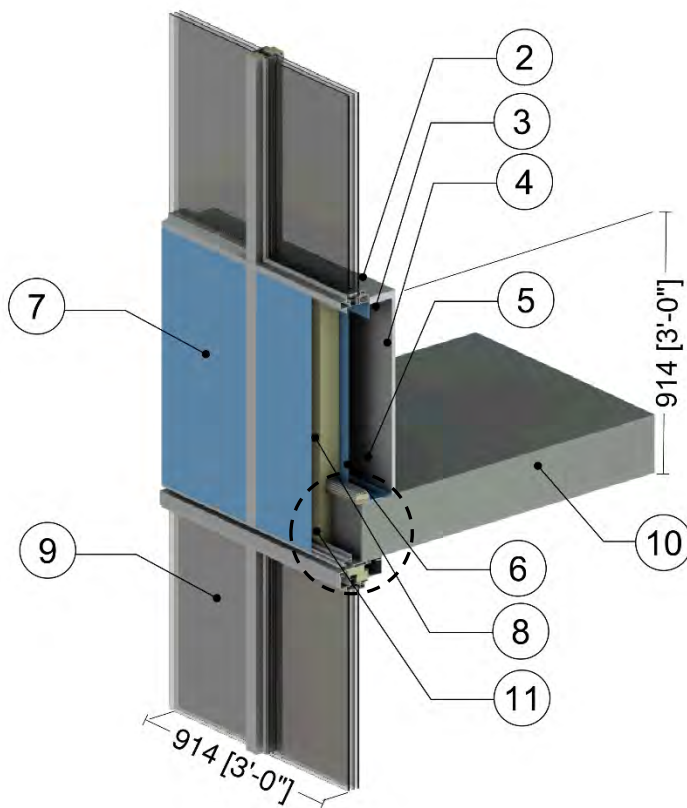

A. Improved Bypass with 1" (25mm) insulation behind horizontal mullion, *Standard* Deflection Header Thermal Break Placement

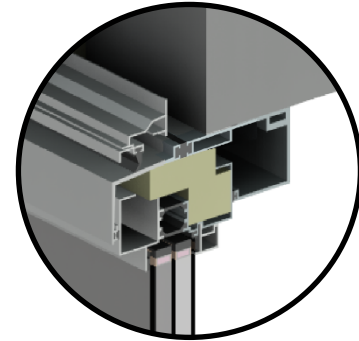

B. Improved Bypass with 1" (25mm) insulation behind horizontal mullion, and Deflection Header Thermal Break in line with Bypass Insulation

ID	Component	Thickness Inches (mm)	Conductivity Btu-in / ft ² ·hr·°F (W/m K)	Nominal Resistance hr·ft ² ·°F/Btu (m ² K/W)	Density lb/ft ³ (kg/m ³)	Specific Heat Btu/lb·°F (J/kg K)
1	Interior Films ¹	-	-	R-0.6 to R-1.1 (0.12 to 0.20 RSI)	-	-
2	Wood Sill	1 1/4" (30)	0.69 (0.10)	-	27.8 (445)	0.45 (1880)
3	Steel Sheet Connected to Studs	18 Gauge	430 (62)	-	489 (7830)	0.12 (500)
4	Gypsum Board	1/2" (13)	1.1 (0.16)	R-0.5 (0.08 RSI)	50 (800)	0.26 (1090)
5	Air in Stud Cavity	3 5/8" (92)	-	R-0.9 (0.16 RSI)	0.075 (1.2)	0.24 (1000)
6	3 5/8" x 1 5/8" Steel Studs (16"o.c.) with Top and Bottom Tracks	18 Gauge	430 (62)	-	489 (7830)	0.12 (500)
7	Aluminum Window Wall Spandrel System with Insulated Backpan: thermally broken frame with insulation within mullions, additional bypass insulation and two deflection header thermal break scenarios, A) Standard, B) Inline with Slab Insulation ²					
8	Backpan Insulation	3" (76)	0.24 (0.034)	R-12.6 (2.22 RSI)	4 (64)	0.20 (850)
9	Aluminum Window Wall Vision System: thermally broken frame ² , triple glazed IGU U _{COG} = 0.14 BTU/hr·ft ² ·°F (0.81 W/m ² K)					
10	Concrete Slab	8" (203)	12.5 (1.8)	-	140 (2250)	0.20 (850)
11	Bypass Insulation	2" (51)	0.24 (0.034)	R-8.4 (1.48 RSI)	4 (64)	0.20 (850)
12	Exterior Film ¹	-	-	R-0.2 (0.03 RSI)	-	-

¹ Value selected from table 1, p. 26.1 of 2009 ASHRAE Handbook – Fundamentals depending on surface orientation

² The thermal conductivity of air spaces within framing was found using ISO 100077-2

Detail 1.2.5

Window Wall System – Full Height Spandrel at Slab Intersection with Spandrel Bypass & No Interior Stud Cavity Insulation

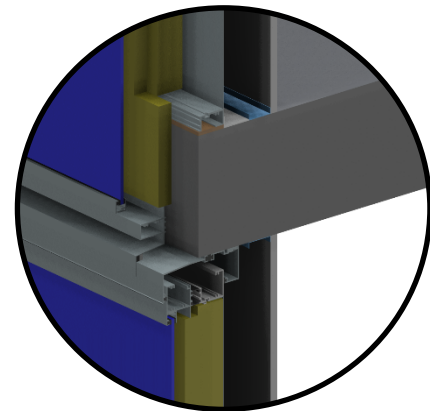
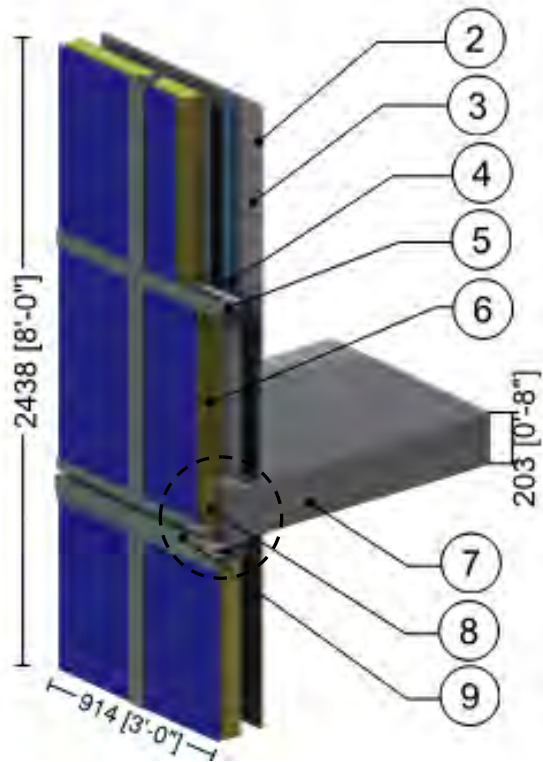

Bypass Detail with Deflection Header and 1/2" (12mm) Air Gap Behind Horizontal Mullion

ID	Component	Thickness Inches (mm)	Conductivity Btu-in / ft ² ·hr·°F (W/m K)	Nominal Resistance hr·ft ² ·°F/Btu (m ² K/W)	Density lb/ft ³ (kg/m ³)	Specific Heat Btu/lb·°F (J/kg K)
1	Interior Films ¹	-	-	R-0.6 to R-1.1 (0.12 to 0.20 RSI)	-	-
2	Gypsum Board	1/2" (13)	1.1 (0.16)	R-0.5 (0.08 RSI)	50 (800)	0.26 (1090)
3	Air in Stud Cavity	3 5/8" (92)	-	R-0.9 (0.16 RSI)	0.075 (1.2)	0.24 (1000)
4	3 5/8" x 1 5/8" Steel Studs (16"o.c.) with Top and Bottom Tracks	18 Gauge	430 (62)	-	489 (7830)	0.12 (500)
5	Full Height Aluminum Window Wall Spandrel System with Insulated Backpan: thermally broken frame, no insulation in mullions ²					
6	Backpan Insulation	Varies	0.24 (0.034)	R-8.4 to R-16.8 (1.48 to 2.96 RSI)	4 (64)	0.20 (850)
7	Concrete Slab	8" (203)	12.5 (1.8)	-	140 (2250)	0.20 (850)
8	Bypass Insulation	1" (25)	0.20 (0.029)	R-5 (0.88 RSI)	1.8 (28)	0.29 (1220)
9	Aluminum Flashing	14 Gauge	1109 (160)	-	171 (2739)	0.21 (900)
10	Exterior Film ¹	-	-	R-0.2 (0.03 RSI)	-	-

¹ Value selected from table 1, p. 26.1 of 2009 ASHRAE Handbook – Fundamentals depending on surface orientation

² The thermal conductivity of air spaces within framing was found using ISO 100077-2

Detail 1.2.6

Window Wall System – Full Height Spandrel at Slab Intersection with Spandrel Bypass & Interior Spray Foam Insulation

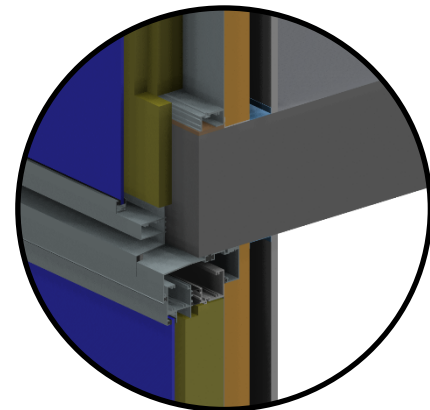
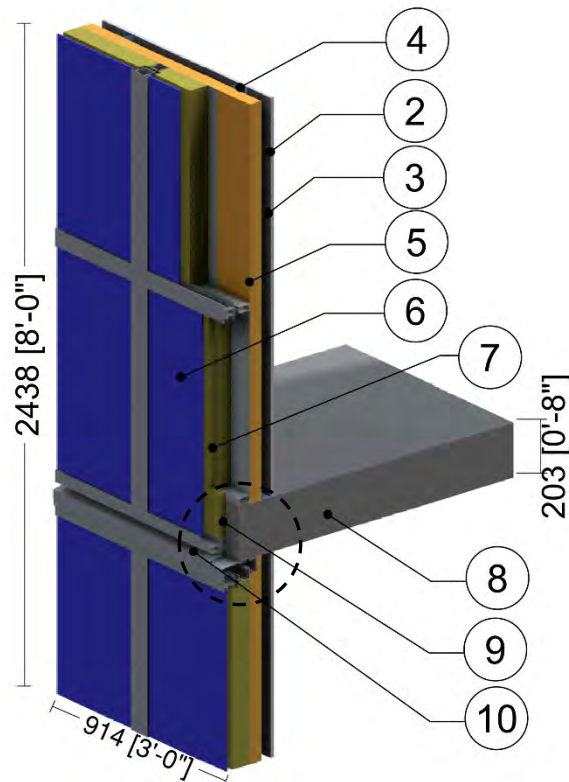

Bypass Detail with Deflection Header and 1/2" (12mm) Air Gap Behind Horizontal Mullion

ID	Component	Thickness Inches (mm)	Conductivity Btu-in / ft ² ·hr·°F (W/m K)	Nominal Resistance hr·ft ² ·°F/Btu (m ² K/W)	Density lb/ft ³ (kg/m ³)	Specific Heat Btu/lb·°F (J/kg K)
1	Interior Films ¹	-	-	R-0.6 to R-1.1 (0.12 to 0.20 RSI)	-	-
2	Gypsum Board	1/2" (13)	1.1 (0.16)	R-0.5 (0.08 RSI)	50 (800)	0.26 (1090)
3	Air in Stud Cavity	1 5/8" (41)	-	R-0.9 (0.16 RSI)	0.075 (1.2)	0.24 (1000)
4	3 5/8" x 1 5/8" Steel Studs (16"o.c.) with Top and Bottom Tracks	18 Gauge	430 (62)	-	489 (7830)	0.12 (500)
5	Continuous Spray Foam Insulation	2" (51)	0.17 (0.024)	R-12 (2.11 RSI)	2.8 (39)	0.35 (1470)
6	Full Height Aluminum Window Wall Spandrel System with Insulated Backpan: thermally broken frame, no insulation in mullions ²					
7	Backpan Insulation	Varies	0.24 (0.034)	R-8.4 to R-16.8 (1.48 to 2.96 RSI)	4 (64)	0.20 (850)
8	Concrete Slab	8" (203)	12.5 (1.8)	-	140 (2250)	0.20 (850)
9	Bypass Insulation	1" (25)	0.20 (0.029)	R-5 (0.88 RSI)	1.8 (28)	0.29 (1220)
10	Aluminum Flashing	14 Gauge	1109 (160)	-	171 (2739)	0.21 (900)
11	Exterior Film ¹	-	-	R-0.2 (0.03 RSI)	-	-

¹ Value selected from table 1, p. 26.1 of 2009 ASHRAE Handbook – Fundamentals depending on surface orientation

² The thermal conductivity of air spaces within framing was found using ISO 100077-2

Detail 1.2.7

Window Wall System – Full Height Insulated Frame at Slab Intersection with Improved Spandrel Bypass & No Interior Stud Cavity Insulation

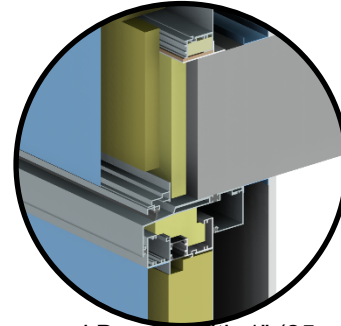
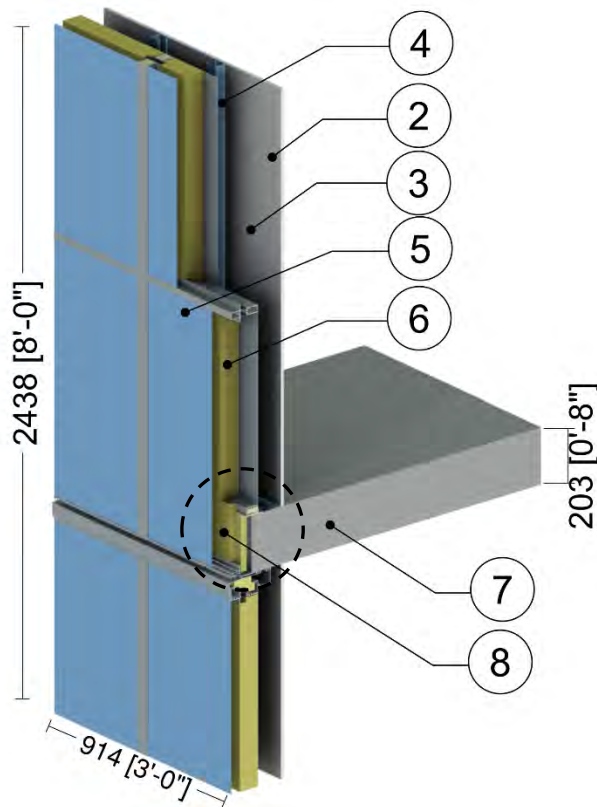

A. Improved Bypass with 1" (25mm) insulation behind horizontal mullion, *Standard* Deflection Header Thermal Break Placement

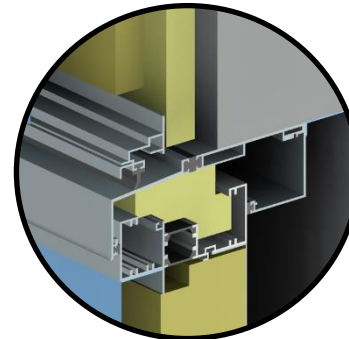

B. Improved Bypass with 1" (25mm) insulation behind horizontal mullion, and Deflection Header Thermal Break in line with Bypass Insulation

ID	Component	Thickness Inches (mm)	Conductivity Btu-in / ft ² -hr-°F (W/m K)	Nominal Resistance hr-ft ² -°F/Btu (m ² K/W)	Density lb/ft ³ (kg/m ³)	Specific Heat Btu/lb-°F (J/kg K)
1	Interior Films ¹	-	-	R-0.6 to R-1.1 (0.12 to 0.20 RSI)	-	-
2	Gypsum Board	1/2" (13)	1.1 (0.16)	R-0.5 (0.08 RSI)	50 (800)	0.26 (1090)
3	Air in Stud Cavity	3 5/8" (92)	-	R-0.9 (0.16 RSI)	0.075 (1.2)	0.24 (1000)
4	3 5/8" x 1 5/8" Steel Studs (16"o.c.) with Top and Bottom Tracks	18 Gauge	430 (62)	-	489 (7830)	0.12 (500)
5	Full Height Aluminum Window Wall Spandrel System with Insulated Backpan: thermally broken frame with insulation within mullions, additional bypass insulation and two deflection header thermal break scenarios, A) Standard, B) Inline with Slab Insulation ²					
6	Backpan Insulation	3" (76)	0.24 (0.034)	R-12.6 (2.22 RSI)	4 (64)	0.20 (850)
7	Concrete Slab	8" (203)	12.5 (1.8)	-	140 (2250)	0.20 (850)
8	Bypass Insulation	2" (51)	0.24 (0.034)	R-8.4 (1.48 RSI)	4 (64)	0.20 (850)
9	Exterior Film ¹	-	-	R-0.2 (0.03 RSI)	-	-

¹ Value selected from table 1, p. 26.1 of 2009 ASHRAE Handbook – Fundamentals depending on surface orientation

² The thermal conductivity of air spaces within framing was found using ISO 100077-2

Detail 1.2.8

Window Wall System – Full Height Insulated Frame at Slab Intersection with Hybridized Clipped Spandrel & No Interior Stud Cavity Insulation

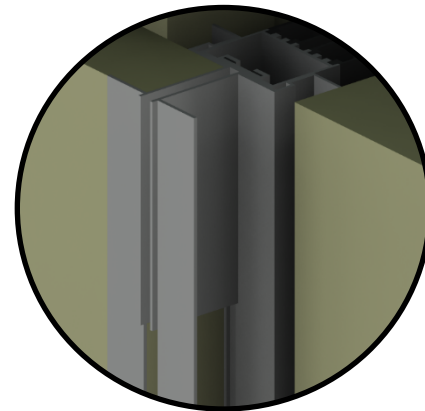
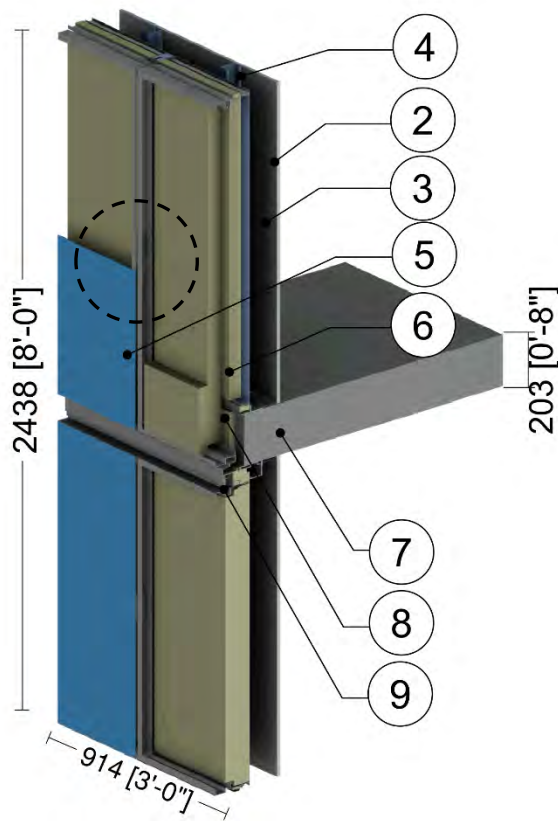

Spandrel Clip and Insulation outboard of vertical mullions

ID	Component	Thickness Inches (mm)	Conductivity Btu-in / ft ² ·hr·°F (W/m K)	Nominal Resistance hr·ft ² ·°F/Btu (m ² K/W)	Density lb/ft ³ (kg/m ³)	Specific Heat Btu/lb·°F (J/kg K)
1	Interior Films ¹	-	-	R-0.6 to R-1.1 (0.12 to 0.20 RSI)	-	-
2	Gypsum Board	1/2" (13)	1.1 (0.16)	R-0.5 (0.08 RSI)	50 (800)	0.26 (1090)
3	Air in Stud Cavity	3 5/8" (92)	-	R-0.9 (0.16 RSI)	0.075 (1.2)	0.24 (1000)
4	3 5/8" x 1 5/8" Steel Studs (16"o.c.) with Top and Bottom Tracks	18 Gauge	430 (62)	-	489 (7830)	0.12 (500)
5	Full Height Aluminum Window Wall Spandrel System with Insulated Backpan: thermally broken frame with hybrid clip system on mullions holding up metal panel, allowing for extended amounts of insulation in the backpan and 1" of insulation in front of the mullions ²					
6	Backpan Insulation	5.5" (140)	0.24 (0.034)	R-23.1 (4.07 RSI)	4 (64)	0.20 (850)
7	Concrete Slab	8" (203)	12.5 (1.8)	-	140 (2250)	0.20 (850)
8	Bypass Insulation	5.25" (133)	0.24 (0.034)	R-22.1 (3.88 RSI)	4 (64)	0.20 (850)
9	Aluminum Flashing	14 Gauge	1109 (160)	-	171 (2739)	0.21 (900)
10	Exterior Film ¹	-	-	R-0.2 (0.03 RSI)	-	-

¹ Value selected from table 1, p. 26.1 of 2009 ASHRAE Handbook – Fundamentals depending on surface orientation

² The thermal conductivity of air spaces within framing was found using ISO 100077-2

Detail 1.2.9

Window Wall System with Uprand Spandrel Section – Intermediate Floor Intersection with Spandrel Bypass and no Interior Stud Cavity Insulation

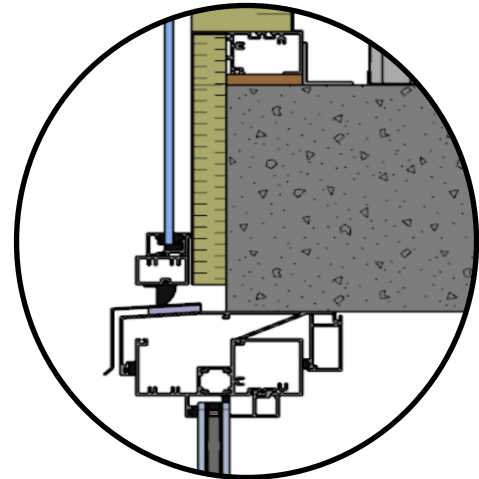
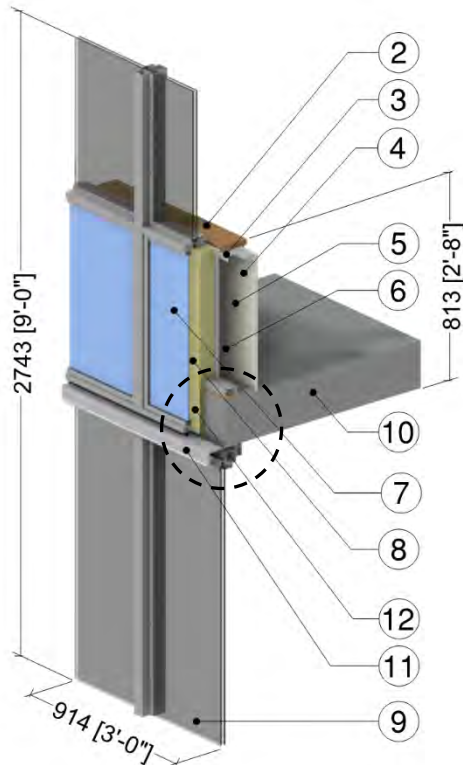

Bypass Detail with Deflection Header

ID	Component	Thickness Inches (mm)	Conductivity Btu-in / ft ² ·hr·°F (W/m K)	Nominal Resistance hr·ft ² ·°F/Btu (m ² K/W)	Density lb/ft ³ (kg/m ³)	Specific Heat Btu/lb·°F (J/kg K)
1	Interior Film ¹	-	-	R-0.6 to R-1.1 (0.11 RSI to 0.20 RSI)	-	-
2	Wood Sill	1" (25)	0.69 (0.10)	-	27.8 (445)	0.45 (1880)
3	Steel Track Connected to Studs	18 Gauge	430 (62)	-	489 (7830)	0.12 (500)
4	Gypsum Board	1/2" (13)	1.1 (0.16)	R-0.5 (0.08 RSI)	50 (800)	0.26 (1090)
5	Air in Stud Cavity	3 5/8" (92)	-	R-0.9 (0.16 RSI)	0.075 (1.2)	0.24 (1000)
6	1 5/8" x 1 5/8" Steel Studs (16" o.c.) with Top and Bottom Tracks	18 Gauge	430 (62)	-	489 (7830)	0.12 (500)
7	Aluminum Window Wall Spandrel System with Insulated Backpan: thermally broken frame, no insulation in mullions ²					
8	Backpan Insulation	3" (76)	0.24 (0.034)	R-12.6 (2.22 RSI)	1.8 (28)	0.29 (1220)
9	Aluminum Window Wall Vision System: thermally broken frame ² , double glazed IGU U _{COG} = 0.242 BTU/hr·ft ² ·°F (1.37 W/m ² K)					
10	Concrete Floor Slab	8" (203)	12.5 (1.8)	-	140 (2250)	0.20 (850)
11	Aluminum Flashing	14 Gauge	1109 (160)	-	171 (2739)	0.21 (900)
12	Bypass Insulation	1" (25)	0.24 (0.034)	R-4.2 (0.74 RSI)	1.8 (28)	0.29 (1220)
13	Exterior Film ¹	-	-	R-0.2 (0.03 RSI)	-	-

¹ Value selected from table 1, p. 26.1 of 2009 ASHRAE Handbook – Fundamentals depending on surface orientation

² The thermal conductivity of air spaces within framing was found using ISO 100077-2

Detail 1.2.10

Window Wall System with Full Height Vision Section – Intermediate Floor Intersection with Spandrel Bypass and no Interior Stud Cavity Insulation

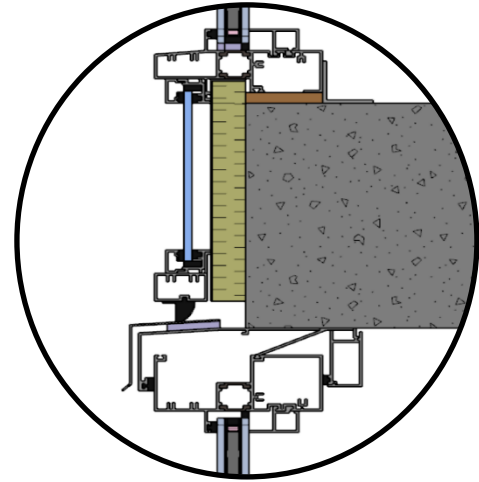
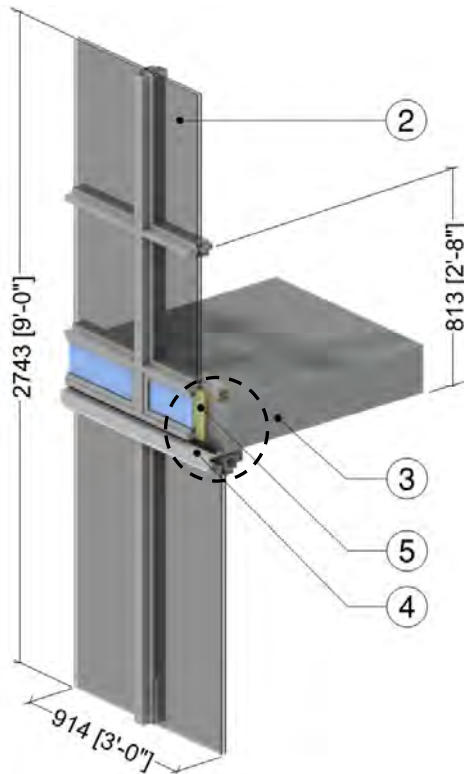

Bypass Detail with Deflection Header

ID	Component	Thickness Inches (mm)	Conductivity Btu-in / ft ² ·hr·°F (W/m K)	Nominal Resistance hr·ft ² ·°F/Btu (m ² K/W)	Density lb/ft ³ (kg/m ³)	Specific Heat Btu/lb·°F (J/kg K)
1	Interior Film ¹	-	-	R-0.6 to R-1.1 (0.11 RSI to 0.20 RSI)	-	-
2	Aluminum Window Wall Vision System: thermally broken frame ² , double glaze IGU U _{COG} = 0.242 BTU/hr·ft ² ·°F (1.37 W/m ² K)					
3	Concrete Floor Slab	8" (203)	12.5 (1.8)	-	140 (2250)	0.20 (850)
4	Aluminum Flashing	14 Gauge	1109 (160)	-	171 (2739)	0.21 (900)
5	Bypass Insulation	1" (25)	0.24 (0.034)	R-4.2 (0.74 RSI)	1.8 (28)	0.29 (1220)
6	Exterior Film ¹	-	-	R-0.2 (0.03 RSI)	-	-

¹ Value selected from table 1, p. 26.1 of 2009 ASHRAE Handbook – Fundamentals depending on surface orientation

² The thermal conductivity of air spaces within framing was found using ISO 100077-2

Detail 1.3.1

Window Wall System – Uninsulated Concrete Parapet & Roof Intersection

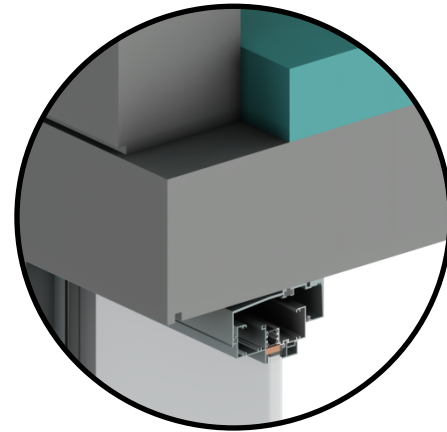
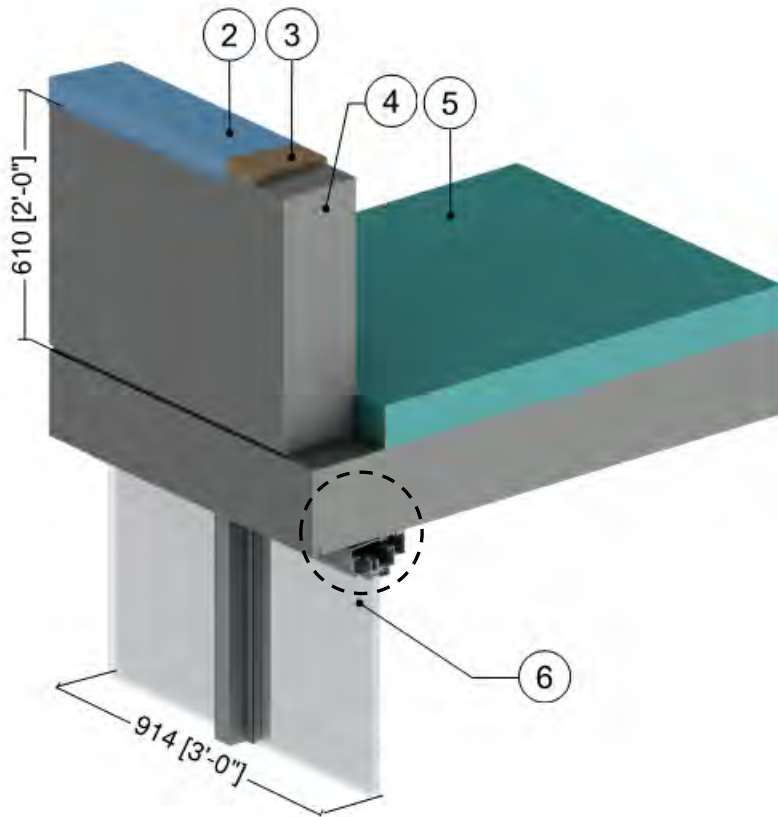

Parapet Intersection Detail

ID	Component	Thickness Inches (mm)	Conductivity Btu-in / ft ² -hr-°F (W/m K)	Nominal Resistance hr-ft ² -°F/Btu (m ² K/W)	Density lb/ft ³ (kg/m ³)	Specific Heat Btu/lb-°F (J/kg K)
1	Interior Films ¹	-	-	R-0.6 to R-1.1 (0.12 to 0.20 RSI)	-	-
2	Parapet Flashing	18 Gauge	430 (62)	-	489 (7830)	0.12 (500)
3	Wood Blocking	1 1/4" (30)	0.69 (0.10)	-	27.8 (445)	0.45 (1880)
4	Concrete Slab and Parapet	8" (203)	12.5 (1.8)	-	140 (2250)	0.20 (850)
5	Roof Insulation	4" (102)	0.20 (0.029)	R-20 (3.5 RSI)	1.8 (28)	0.29 (1220)
6	Aluminum Window Wall Vision System: thermally broken frame ² , no insulation in mullions, double glazed IGU U _{COG} = 0.32 BTU/hr-ft ² -°F (1.82 W/m ² K)					
7	Exterior Film ¹	-	-	R-0.2 (0.03 RSI)	-	-

¹ Value selected from table 1, p. 26.1 of 2009 ASHRAE Handbook – Fundamentals depending on surface orientation

² The thermal conductivity of air spaces within framing was found using ISO 100077-2

Detail 1.3.2

Window Wall System – Partially Insulated Concrete Parapet & Roof Intersection

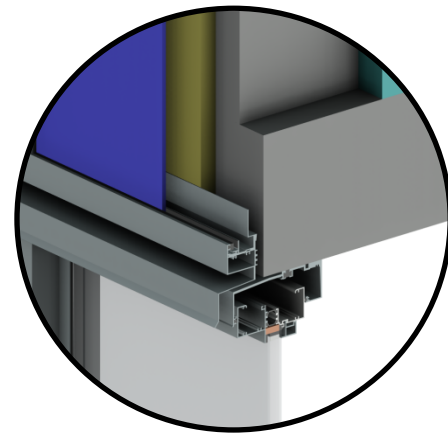
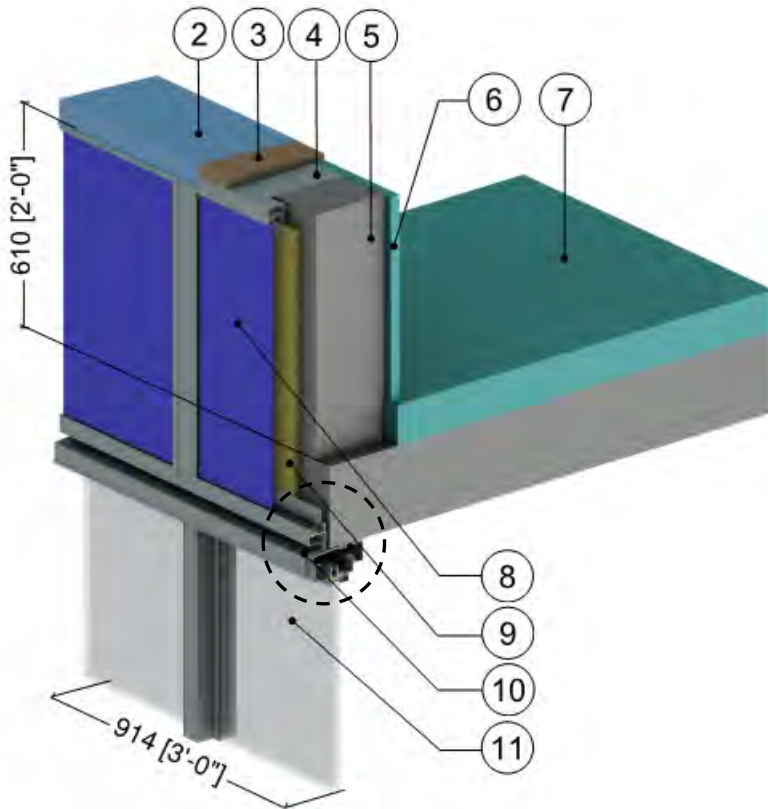

Parapet Intersection Detail

ID	Component	Thickness Inches (mm)	Conductivity Btu-in / ft ² ·hr·°F (W/m K)	Nominal Resistance hr·ft ² ·°F/Btu (m ² K/W)	Density lb/ft ³ (kg/m ³)	Specific Heat Btu/lb·°F (J/kg K)
1	Interior Films ¹	-	-	R-0.6 to R-1.1 (0.12 to 0.20 RSI)	-	-
2	Parapet Flashing	18 Gauge	430 (62)	-	489 (7830)	0.12 (500)
3	Wood Blocking	1 1/4" (30)	0.63 (0.09)	-	27.8 (445)	0.45 (1880)
4	Steel Connector Plate	18 Gauge	430 (62)	-	489 (7830)	0.12 (500)
5	Concrete Slab and Parapet	8" (203)	12.5 (1.8)	-	140 (2250)	0.20 (850)
6	Parapet Bypass Insulation	1" (25)	0.20 (0.029)	R-5 (0.88 RSI)	1.8 (28)	0.29 (1220)
7	Roof Insulation	4" (102)	0.20 (0.029)	R-20 (3.5 RSI)	1.8 (28)	0.29 (1220)
8	Aluminum Window Wall Spandrel System with Insulated Backpan: thermally broken frame, no insulation in mullions ²					
9	Window Wall Mineral Wool Insulation	Varies	0.24 (0.034)	R-8.4 to R-16.8 (1.48 to 2.96 RSI)	4 (64)	0.20 (850)
10	Aluminum Flashing	14 Gauge	1109 (160)	-	171 (2739)	0.21 (900)
11	Aluminum Window Wall Vision System: thermally broken frame ² , no insulation in mullions, double glazed IGU U _{COG} = 0.32 BTU/hr·ft ² ·°F (1.82 W/m ² K)					
12	Exterior Film ¹	-	-	R-0.2 (0.03 RSI)	-	-

¹ Value selected from table 1, p. 26.1 of 2009 ASHRAE Handbook – Fundamentals depending on surface orientation

² The thermal conductivity of air spaces within framing was found using ISO 100077-2

Detail 1.4.1

Window Wall System – Inside Corner with Spandrel to Vision Transition & No Interior Stud Cavity Insulation

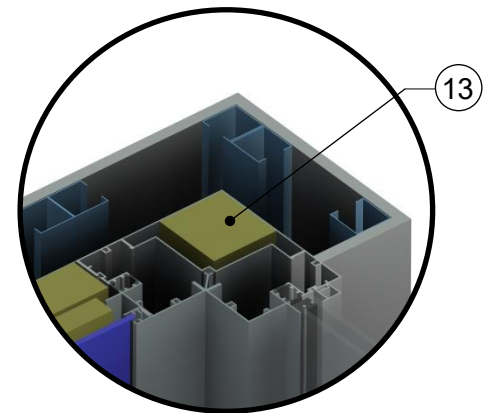
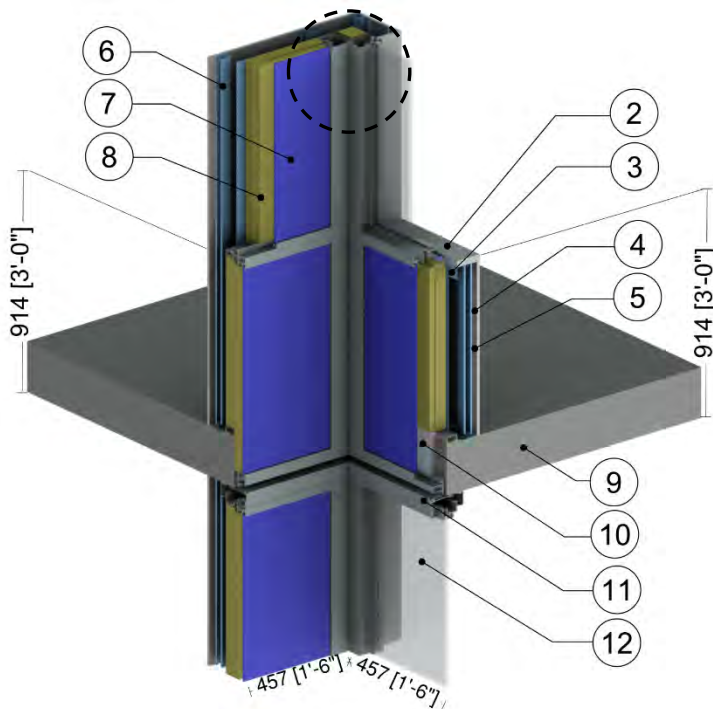

Corner Post Detail

ID	Component	Thickness Inches (mm)	Conductivity Btu-in / ft ² -hr-°F (W/m K)	Nominal Resistance hr-ft ² -°F/Btu (m ² K/W)	Density lb/ft ³ (kg/m ³)	Specific Heat Btu/lb-°F (J/kg K)
1	Interior Films ¹	-	-	R-0.6 to R-1.1 (0.12 to 0.20 RSI)	-	-
2	Wood Sill	1 1/4" (30)	0.69 (0.10)	-	27.8 (445)	0.45 (1880)
3	Steel Sheet Connected to Studs	18 Gauge	430 (62)	-	489 (7830)	0.12 (500)
4	Gypsum Board	1/2" (13)	1.1 (0.16)	R-0.5 (0.08 RSI)	50 (800)	0.26 (1090)
5	Air in Stud Cavity	3 5/8" (92)	-	R-0.9 (0.16 RSI)	0.075 (1.2)	0.24 (1000)
6	1 5/8" x 1 5/8" Steel Studs (16"o.c.) with Top and Bottom Tracks	18 Gauge	430 (62)	-	489 (7830)	0.12 (500)
7	Full Height Aluminum Window Wall Spandrel System with Insulated Backpan: thermally broken frame, no insulation in mullions ²					
8	Backpan Insulation	Varies	0.24 (0.034)	R-8.4 to R-16.8 (1.48 to 2.96 RSI)	4 (64)	0.20 (850)
9	Concrete Slab	8" (203)	12.5 (1.8)	-	140 (2250)	0.20 (850)
10	Bypass Insulation	1" (25)	0.20 (0.029)	R-5 (0.88 RSI)	1.8 (28)	0.29 (1220)
11	Aluminum Flashing	14 Gauge	1109 (160)	-	171 (2739)	0.21 (900)
12	Aluminum Window Wall Vision System: thermally broken frame ² , no insulation in mullions, double glazed IGU U _{COG} = 0.32 BTU/hr-ft ² -°F (1.82 W/m ² K)					
13	Post Insulation	3" (76)	0.24 (0.034)	R-12.6 (2.22 RSI)	4 (64)	0.20 (850)
14	Exterior Film ¹	-	-	R-0.2 (0.03 RSI)	-	-

¹ Value selected from table 1, p. 26.1 of 2009 ASHRAE Handbook – Fundamentals depending on surface orientation

² The thermal conductivity of air spaces within framing was found using ISO 100077-2

Detail 1.4.2

Window Wall System – Inside Corner with Spandrel to Vision Transition & Interior Spray Foam Insulation

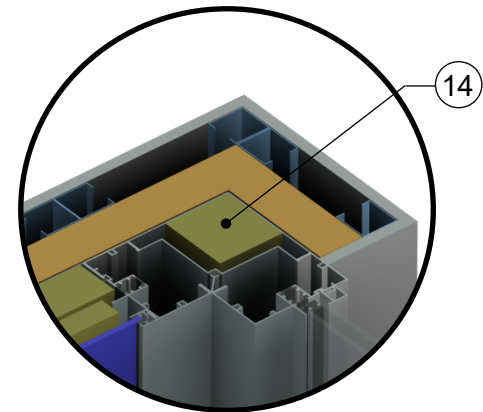
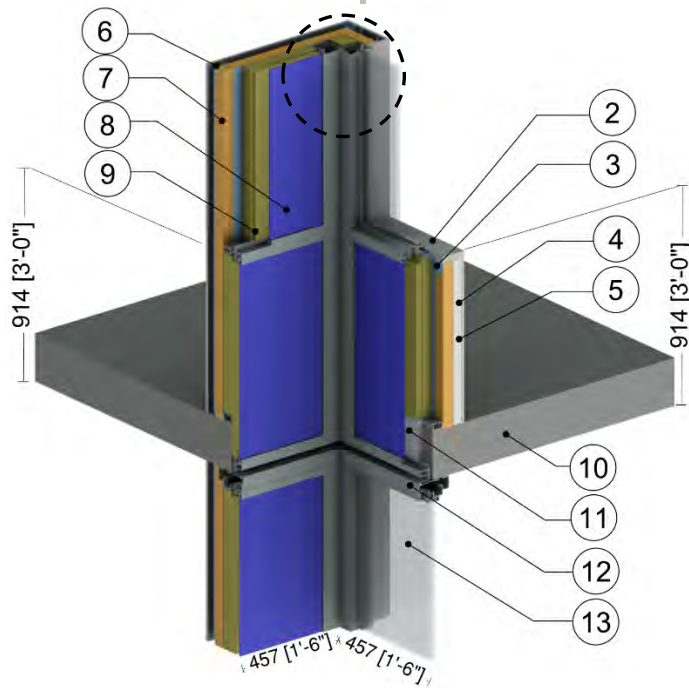

Corner Post Detail

ID	Component	Thickness Inches (mm)	Conductivity Btu-in / ft ² ·hr·°F (W/m K)	Nominal Resistance hr·ft ² ·°F/Btu (m ² K/W)	Density lb/ft ³ (kg/m ³)	Specific Heat Btu/lb·°F (J/kg K)
1	Interior Films ¹	-	-	R-0.6 to R-1.1 (0.12 to 0.20 RSI)	-	-
2	Wood Sill	1 1/4" (30)	0.69 (0.10)	-	27.8 (445)	0.45 (1880)
3	Steel Sheet Connected to Studs	18 Gauge	430 (62)	-	489 (7830)	0.12 (500)
4	Gypsum Board	1/2" (13)	1.1 (0.16)	R-0.5 (0.08 RSI)	50 (800)	0.26 (1090)
5	Air in Stud Cavity	1 5/8" (41)	-	R-0.9 (0.16 RSI)	0.075 (1.2)	0.24 (1000)
6	1 5/8" x 1 5/8" Steel Studs (16"o.c.) with Top and Bottom Tracks	18 Gauge	430 (62)	-	489 (7830)	0.12 (500)
7	Continuous Spray Foam Insulation	2" (51)	0.17 (0.024)	R-12 (2.11 RSI)	2.8 (39)	0.35 (1470)
8	Full Height Aluminum Window Wall Spandrel System with Insulated Backpan: thermally broken frame, no insulation in mullions ²					
9	Backpan Insulation	Varies	0.24 (0.034)	R-8.4 to R-16.8 (1.48 to 2.96 RSI)	4 (64)	0.20 (850)
10	Concrete Slab	8" (203)	12.5 (1.8)	-	140 (2250)	0.20 (850)
11	Bypass Insulation	1" (25)	0.20 (0.029)	R-5 (0.88 RSI)	1.8 (28)	0.29 (1220)
12	Aluminum Flashing	14 Gauge	1109 (160)	-	171 (2739)	0.21 (900)
13	Aluminum Window Wall Vision System: thermally broken frame ² , no insulation in mullions, double glazed IGU U _{COG} = 0.32 BTU/hr·ft ² ·°F (1.82 W/m ² K)					
14	Post Insulation	3" (76)	0.24 (0.034)	R-12.6 (2.22 RSI)	4 (64)	0.20 (850)
15	Exterior Film ¹	-	-	R-0.2 (0.03 RSI)	-	-

¹ Value selected from table 1, p. 26.1 of 2009 ASHRAE Handbook – Fundamentals depending on surface orientation

² The thermal conductivity of air spaces within framing was found using ISO 100077-2

Detail 1.5.1

Window Wall System with Insulated Spandrel Panel – Uninsulated Interior Concrete Wall and Intermediate Floor Intersection

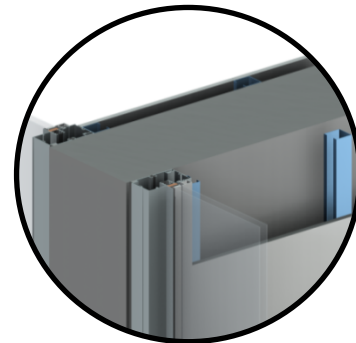
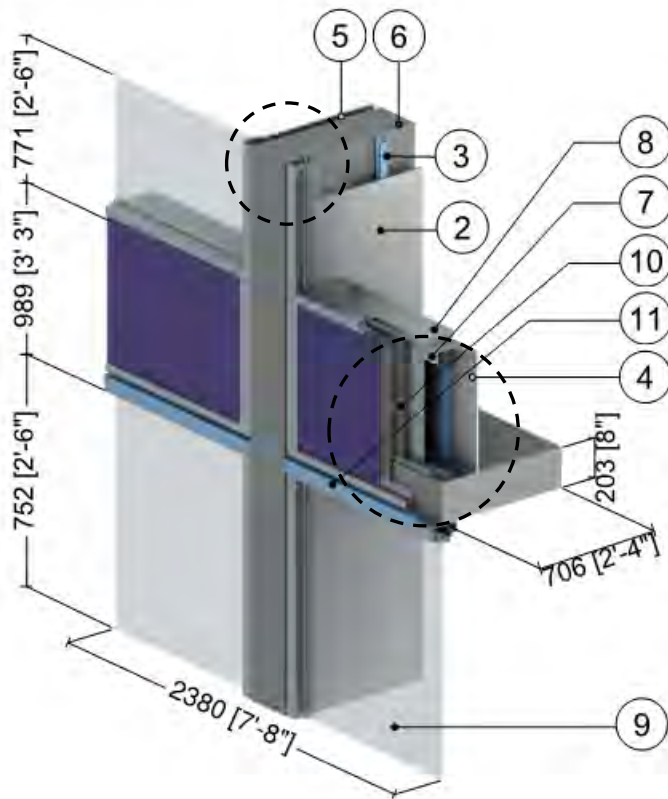

Concrete Wall Intersection Detail with no Interior Insulation

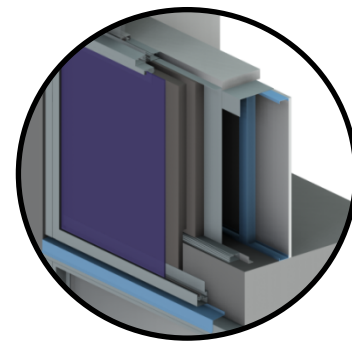

Spandrel Bypass Detail

ID	Component	Thickness Inches (mm)	Conductivity Btu-in / ft ² ·hr·°F (W/m K)	Nominal Resistance hr·ft ² ·°F/Btu (m ² K/W)	Density lb/ft ³ (kg/m ³)	Specific Heat Btu/lb·°F (J/kg K)
1	Interior Films ¹	-	-	R-0.6 to R-1.1 (0.12 to 0.20 RSI)	-	-
2	Gypsum Board	1/2" (13)	1.1 (0.16)	R-0.5 (0.08 RSI)	50 (800)	0.26 (1090)
3	1 5/8" x 1 5/8" Steel Studs with Top and Bottom Tracks	18 Gauge	430 (62)	-	489 (7830)	0.12 (500)
4	Air in Sill Stud Cavity	3 5/8" (92)	-	R-0.9 (RSI-0.16)	0.075 (1.2)	0.24 (1000)
5	Air in Partition Wall Cavity	1 5/8" (41)	-	R-0.9 (RSI-0.16)	0.075 (1.2)	0.24 (1000)
6	Concrete Wall/Floor Slab	8" (203)	12.5 (1.8)	-	140 (2250)	0.20 (850)
7	Steel Sheet Connected to Studs	18 Gauge	430 (62)	-	489 (7830)	0.12 (500)
8	Wood Sill	1 1/4" (30)	0.69 (0.10)	-	31 (500)	0.45 (1880)
9	Aluminum Window Wall Vision System: thermally broken frame ² , no insulation in mullions, double glazed IGU U _{COG} = 0.32 BTU/hr·ft ² ·°F (1.82 W/m ² K)					
10	Backpan insulation	Varies	0.24 (0.034)	R-8.4 to R-16.8 (1.48 to 2.96 RSI)	4 (64)	0.20 (850)
11	Aluminum Flashing	14 Gauge	1109 (160)	-	171 (2739)	0.21 (900)
12	Exterior Air Film ¹	-	-	R-0.2 (0.03 RSI)	-	-

¹ Value selected from table 1, p. 26.1 of 2009 ASHRAE Handbook – Fundamentals depending on surface orientation

² The thermal conductivity of air spaces within framing was found using ISO 100077-2

Detail 1.5.2

Window Wall System with Insulated Spandrel Panel – Insulated Interior Concrete Wall and Intermediate Floor Intersection

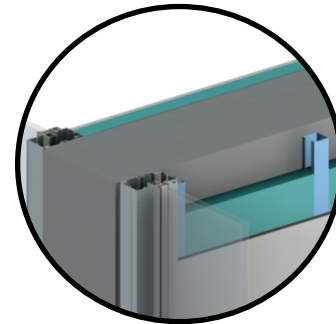
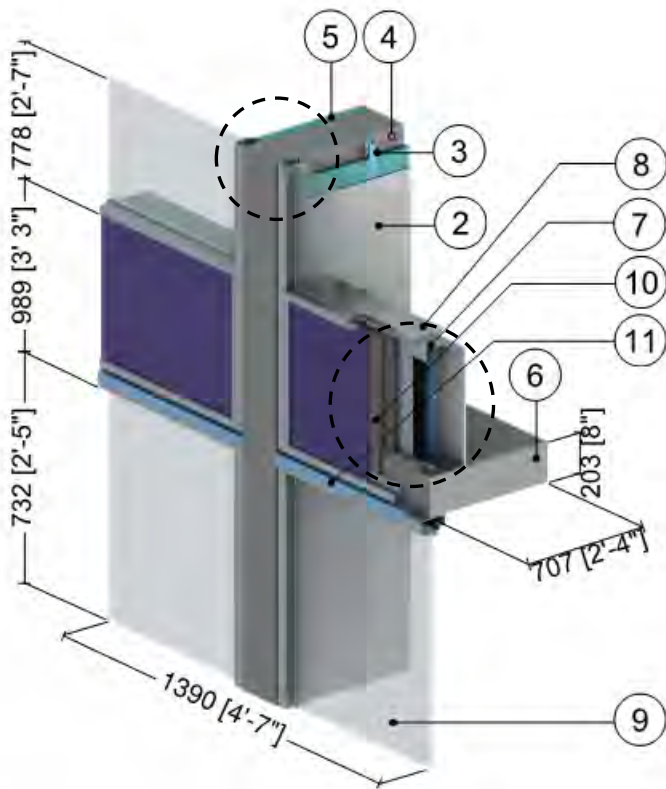

Interior Concrete Wall Intersection Detail with Interior Insulation

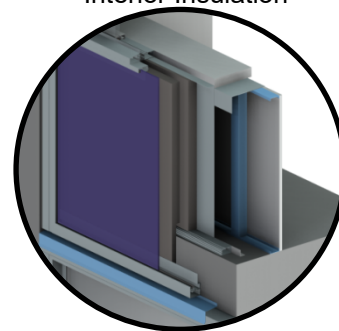

Spandrel Bypass Detail

ID	Component	Thickness Inches (mm)	Conductivity Btu-in / ft ² -hr-°F (W/m K)	Nominal Resistance hr-ft ² -°F/Btu (m ² K/W)	Density lb/ft ³ (kg/m ³)	Specific Heat Btu/lb-°F (J/kg K)
1	Interior Film ¹	-	-	R-0.6 to R-1.1 (0.12 to 0.20 RSI)	-	-
2	Gypsum Board	1/2" (13)	1.1 (0.16)	R-0.5 (0.08 RSI)	50 (800)	0.26 (1090)
3	3 5/8" x 1 5/8" Steel Studs with Top and Bottom Tracks	18 Gauge	430 (62)	-	489 (7830)	0.12 (500)
4	Air in Sill Stud Cavity	3 5/8" (92)	-	R-0.9 (RSI-0.16)	0.075 (1.2)	0.24 (1000)
5	Rigid Insulation	1" (25)	-	R-5 (0.88 RSI)	1.8 (28)	0.29 (1220)
6	Concrete Wall/Floor Slab	8" (203)	12.5 (1.8)	-	140 (2250)	0.20 (850)
7	Steel Sheet Connected to Studs	18 Gauge	430 (62)	-	489 (7830)	0.12 (500)
8	Wood Sill	1 1/4" (30)	0.69 (0.10)	-	31 (500)	0.45 (1880)
9	Aluminum Window Wall Vision System: thermally broken frame ² , no insulation in mullions, double glazed IGU U _{COG} = 0.32 BTU/hr-ft ² -°F (1.82 W/m ² K)					
10	Backpan insulation	Varies	0.24 (0.034)	R-8.4 to R-16.8 (1.48 to 2.96 RSI)	4 (64)	0.20 (850)
11	Aluminum Flashing	14 Gauge	1109 (160)	-	171 (2739)	0.21 (900)
12	Exterior Film ¹	-	-	R-0.2 (0.03 RSI)	-	-

¹ Value selected from table 1, p. 26.1 of 2009 ASHRAE Handbook – Fundamentals depending on surface orientation

² The thermal conductivity of air spaces within framing was found using ISO 100077-2

2.0 Conventional Curtain Wall

Detail 2.1.1	A.2.1
Conventional Curtain Wall System with Insulated Spandrel Panel and 3 5/8" x 1 5/8" Steel Stud (16" o.c.) – Intermediate Floor Intersection & No Interior Insulation in Stud Cavity	
Detail 2.1.2	A.2.2
Conventional Curtain Wall System with Insulated Spandrel Panel and 3 5/8" x 1 5/8" Steel Stud (16" o.c.) – Intermediate Floor Intersection & Spray Foam Insulation in Stud Cavity	
Detail 2.1.3	A.2.3
Conventional Curtain Wall System with Vertical and Horizontal Pressure Plates and 5' x 5' Spandrel Section – Insulated Metal Backpan and Intermediate Floor Intersection	
Detail 2.1.4	A.2.4
Conventional Curtain Wall System with Vertical and Horizontal Pressure Plates and 5' x 5' Spandrel Section – AIM Applications and Intermediate Floor Intersection	
Detail 2.1.5	A.2.5
Conventional Curtain Wall System with Vertical and Horizontal Pressure Plates and 5' x 5' Spandrel Section – Insulated Metal Backpan and Intermediate Floor Intersection	
Detail 2.1.6	A.2.6
Conventional Curtain Wall System with 5' x 5' Spandrel Section – Alternative Glazing Methods and Intermediate Floor Intersection	
Detail 2.1.7	A.2.7
Conventional Curtain Wall System with Vertical and Horizontal Pressure Plates and 5' x 5' Spandrel Section – Insulated Backpan and Improved Glazing at Intermediate Floor Intersection	
Detail 2.1.8	A.2.8
Conventional Curtain Wall System with Vertical and Horizontal Pressure Plates and 5' x 5' Spandrel Section – AIM Applications and Improved Glazing at Intermediate Floor Intersection	
Detail 2.1.9	A.2.9
Conventional Curtain Wall System with Vertical and Horizontal Pressure Plates – Intermediate Mullion and 5' x 5' Spandrel Section – Insulated Backpan and Intermediate Floor Intersection	
Detail 2.1.10	A.2.10
Conventional Curtain Wall System with Vertical and Horizontal Pressure Plates – Intermediate Mullion and 5' x 5' Spandrel Section – AIM Applications and Intermediate Floor Intersection	

Detail 2.1.11	A.2.11
Conventional Curtain Wall System with Insulated Spandrel Panel and 3 5/8" x 1 5/8" Steel Stud (16" o.c.) – Slab Intersection & Spray Foam Insulation in Stud Cavity with Thermal Break Under Stud Cavity and at Anchors	
Detail 2.1.12	A.2.12
Conventional Curtain Wall System with Insulated Spandrel Panel and 3 5/8" x 1 5/8" Steel Studs (16" o.c.) – Slab Intersection & No Metal Back Pan	
Detail 2.1.13	A.2.13
Conventional Curtain Wall System with Insulated Spandrel Panel and 3 5/8" x 1 5/8" Steel Studs (16" o.c.) – Slab Intersection & Metal Back Pan Connected to Side of Frame	
Detail 2.1.14	A.2.14
Conventional Curtain Wall System with Vertical and Horizontal Pressure Plates and 5' x 5' Spandrel Section – Owens Corning Thermafiber Impasse System and Intermediate Floor Intersection	
Detail 2.2.1	A.2.15
Conventional Curtain Wall System with Insulated Spandrel Panel & 3 5/8" x 1 5/8" Steel Stud (16" o.c.) – Un-insulated Concrete with Spandrel & Roof Intersection	
Detail 2.2.2	A.2.16
Conventional Curtain Wall System – Insulated Spandrel & Roof Intersection	
Detail 2.2.3	A.2.17
Conventional Curtain Wall System with Insulated Spandrel Panel and 3 5/8" x 1 5/8" Steel Stud (16" o.c.) – Concrete Parapet Roof Intersection & Spray Foam Insulation in Stud Cavity	
Detail 2.2.4	A.2.18
Conventional Curtain Wall System with Insulated Spandrel Panel & 3 5/8" x 1 5/8" Steel Stud (16" o.c.) – Insulated Concrete with Spandrel & Roof Intersection	
Detail 2.3.1	A.2.19
Conventional Curtain Wall System with Insulated Spandrel Panel– Uninsulated Jamb Intersection with Vision Section	
Detail 2.3.2	A.2.20
Conventional Curtain Wall System with Insulated Spandrel Panel– Rigid Insulated Jamb Intersection with Vision Section	
Detail 2.3.3	A.2.21
Conventional Curtain Wall System with Insulated Spandrel Panel –Aerogel Insulated Jamb Intersection with Vision Section	
Detail 2.4.1	A.2.22
Conventional Curtain Wall with Insulated Spandrel Panel & 3 5/8" x 1 5/8" Steel Stud (16" o.c.) - Beam Intersection Connected to Concrete Slab	

Detail 2.4.2	A.2.23
Conventional Curtain Wall with Insulated Spandrel Panel & 5 5/8" x 1 5/8" Steel Stud (16" o.c.) - Beam Intersection Connected to Steel Beam	
Detail 2.4.3	A.2.24
Conventional Curtain Wall with Insulated Spandrel Panel & 3 5/8" x 1 5/8" Steel Stud (16" o.c.) - Canopy Beam & Gutter Intersection	
Detail 2.4.4	A.2.25
Conventional Curtain Wall with Insulated Spandrel Panel & 5 5/8" x 1 5/8" Steel Stud (16" o.c.) - Beam Intersection Connected to Steel Beam with Additional Mullions	
Detail 2.5.1	A.2.26
Conventional Curtain Wall System - At-Grade Slab Transition	

Detail 2.1.1

Conventional Curtain Wall System with Insulated Spandrel Panel and 3 5/8" x 1 5/8" Steel Stud (16" o.c.) – Intermediate Floor Intersection & No Interior Insulation in Stud Cavity

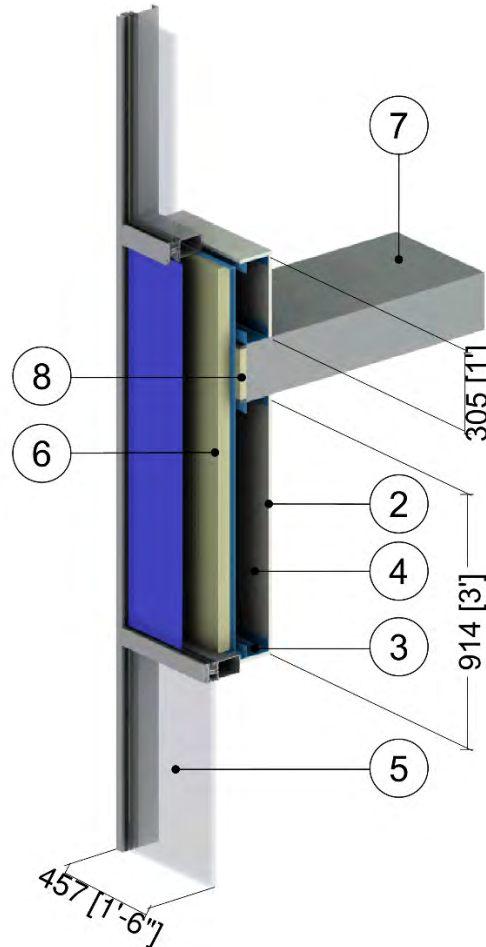

ID	Component	Thickness Inches (mm)	Conductivity Btu-in / ft ² ·hr·°F (W/m K)	Nominal Resistance hr·ft ² ·°F/Btu (m ² K/W)	Density lb/ft ³ (kg/m ³)	Specific Heat Btu/lb·°F (J/kg K)
1	Interior Film ¹	-	-	R-0.6 to R-0.9 (0.11 to 0.16 RSI)	-	-
2	Gypsum Board	1/2" (13)	1.1 (0.16)	R-0.5 (0.08 RSI)	50 (800)	0.26 (1090)
3	3 5/8" x 1 5/8" Steel Studs with Top and Bottom Tracks	18 Gauge	430 (62)	-	489 (7830)	0.12 (500)
4	Air in Stud Cavity	4 5/8" (118)	-	R-0.9 (0.16 RSI)	0.075 (1.2)	0.24 (1000)
5	Conventional curtain wall system with insulated back pan (Pressure plates with minimal thermal break) ²					
6	Backpan Insulation	Varies	-	R-8.4 to R-16.8 (1.48 to 2.96 RSI)	1.8 (28)	0.29 (1220)
7	Concrete Slab	8" (203)	12.5 (1.8)	-	140 (2250)	0.20 (850)
8	Firestop Insulation	1" (25)	0.24 (0.034)	R-4.2 (0.74 RSI)	4 (64)	0.20 (850)
9	Exterior Film ¹	-	-	R-0.2 (0.03 RSI)	-	-

¹ Value selected from table 1, p. 26.1 of 2009 ASHRAE Handbook – Fundamentals depending on surface orientation & surface emissivity. Window values supplemented by ISO 1007-2, Annex B.

² The thermal conductivity of air spaces within curtain wall framing was found using ISO 10077-2.

Detail 2.1.2

Conventional Curtain Wall System with Insulated Spandrel Panel and 3 5/8" x 1 5/8" Steel Stud (16" o.c.) – Intermediate Floor Intersection & Spray Foam Insulation in Stud Cavity

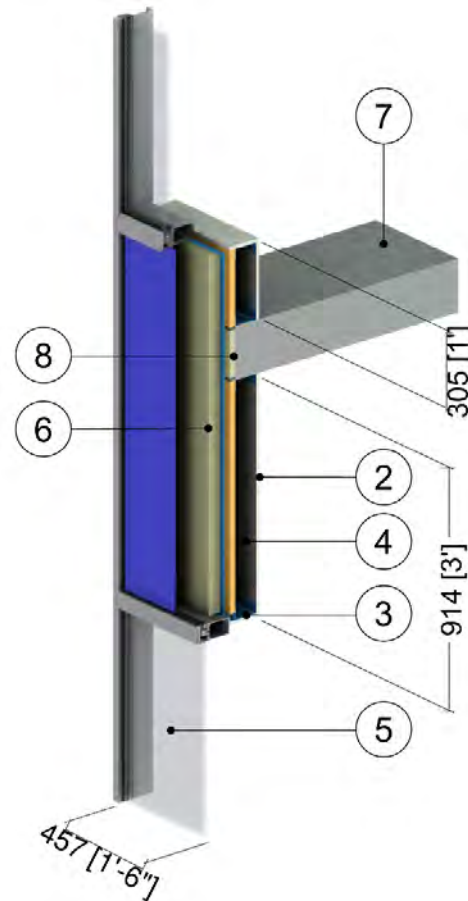

ID	Component	Thickness Inches (mm)	Conductivity Btu-in / ft ² -hr-°F (W/m K)	Nominal Resistance hr-ft ² -°F/Btu (m ² K/W)	Density lb/ft ³ (kg/m ³)	Specific Heat Btu/lb-°F (J/kg K)
1	Interior Film ¹	-	-	R-0.6 to R-0.9 (0.11 to 0.16 RSI)	-	-
2	Gypsum Board	1/2" (13)	1.1 (0.16)	R-0.5 (0.08 RSI)	50 (800)	0.26 (1090)
3	3 5/8" x 1 5/8" Steel Studs with Top and Bottom Tracks	18 Gauge	430 (62)	-	489 (7830)	0.12 (500)
4	Air in Stud Cavity	2 5/8" (67)	-	R-0.9 (0.16 RSI)	0.075 (1.2)	0.24 (1000)
5	Conventional curtain wall system with insulated back pan (Pressure plates with minimal thermal break) ²					
6	Backpan Insulation	Varies	-	R-8.4 to R-16.8 (1.48 to 2.96 RSI)	1.8 (28)	0.29 (1220)
7	Concrete Slab	8" (203)	12.5 (1.8)	-	140 (2250)	0.20 (850)
8	Firestop Insulation	1" (25)	0.24 (0.034)	R-4.2 (0.74 RSI)	4 (64)	0.20 (850)
9	Spray Foam Insulation	2" (51)	0.17 (0.024)	R-12.0 (2.11 RSI)	2.4 (39)	0.35 (1470)
10	Exterior Film ¹	-	-	R-0.2 (0.03 RSI)	-	-

¹ Value selected from table 1, p. 26.1 of 2009 ASHRAE Handbook – Fundamentals depending on surface orientation & surface emissivity. Window values supplemented by ISO 1007-2, Annex B.

² The thermal conductivity of air spaces within curtain wall framing was found using ISO 10077-2.

Detail 2.1.3

Conventional Curtain Wall System with Vertical and Horizontal Pressure Plates and 5' x 5' Spandrel Section – Insulated Metal Backpan and Intermediate Floor Intersection

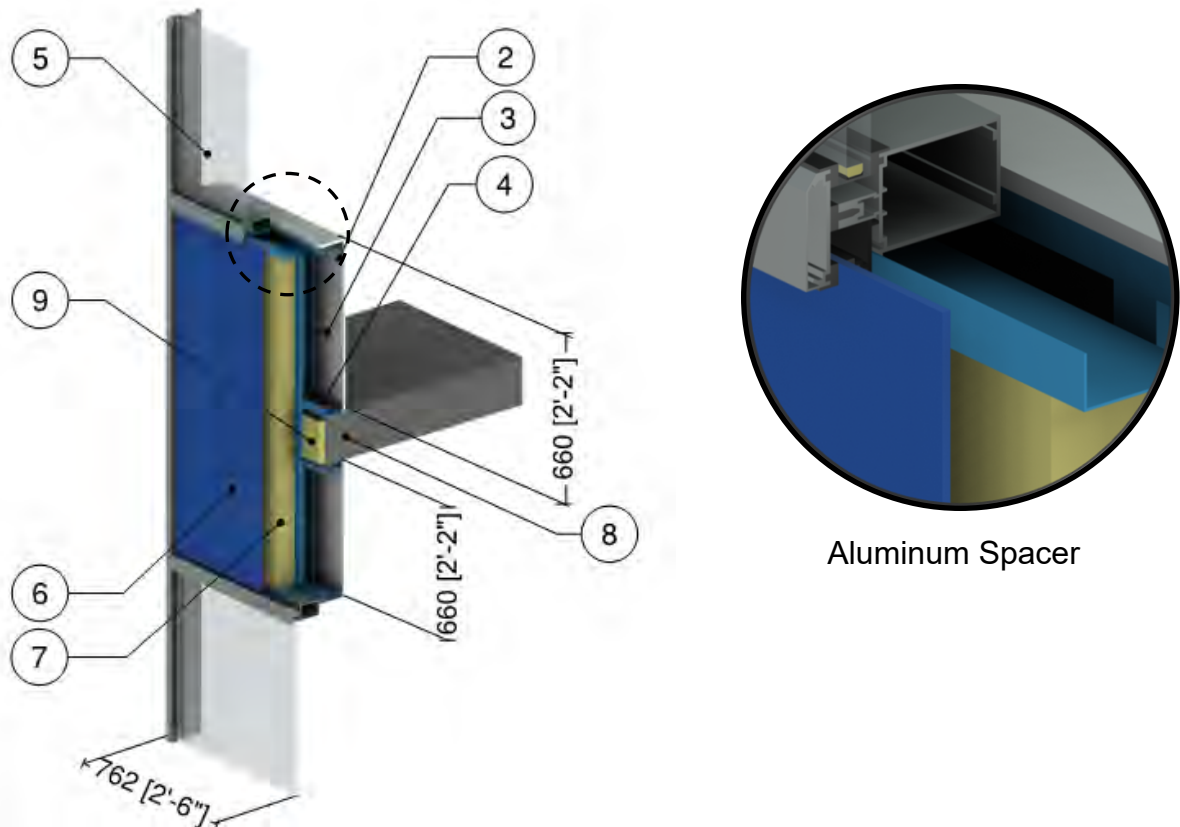

Aluminum Spacer

ID	Component	Thickness Inches (mm)	Conductivity Btu-in / ft ² ·hr·°F (W/m K)	Nominal Resistance hr·ft ² ·°F/Btu (m ² K/W)	Density lb/ft ³ (kg/m ³)	Specific Heat Btu/lb·°F (J/kg K)
1	Interior Films ¹	-	-	R-0.6 to R-1.1 (0.12 to 0.20 RSI)	-	-
2	Gypsum Board	1/2" (13)	1.1 (0.16)	R-0.5 (0.08 RSI)	50 (800)	0.26 (1090)
3	Air in Stud Cavity	3 5/8" (92)	-	R-0.9 (0.16 RSI)	0.075 (1.2)	0.24 (1000)
4	1 5/8" x 1 5/8" Steel Studs (16"o.c.) with Top and Bottom Tracks	18 Gauge	430 (62)	-	489 (7830)	0.12 (500)
5	Conventional Curtain Wall Vision Section: double glazed IGU with aluminum spacer ²					
6	Conventional Curtain Wall Spandrel Section with Backpan Insulation ^{2,3}					
7	Backpan Insulation	4" (100)	0.24 (0.034)	R-16.8 (2.96 RSI)	4 (64)	0.20 (850)
8	Concrete Slab	8" (203)	12.5 (1.8)	-	140 (2250)	0.20 (850)
9	Mineral Wool Insulation	1" (25)	0.24 (0.034)	R-4.2 (0.74 RSI)	4 (64)	0.20 (850)
10	Exterior Film ¹	-	-	R-0.2 (0.03 RSI)	-	-

¹ Value selected from table 1, p. 26.1 of 2009 ASHRAE Handbook – Fundamentals depending on surface orientation

² The thermal conductivity of air spaces within framing was found using ISO 100077-2

³ For a window to wall ratio of 50%

Detail 2.1.4

Conventional Curtain Wall System with Vertical and Horizontal Pressure Plates and 5' x 5' Spandrel Section – AIM Applications and Intermediate Floor Intersection

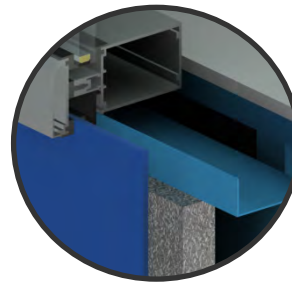
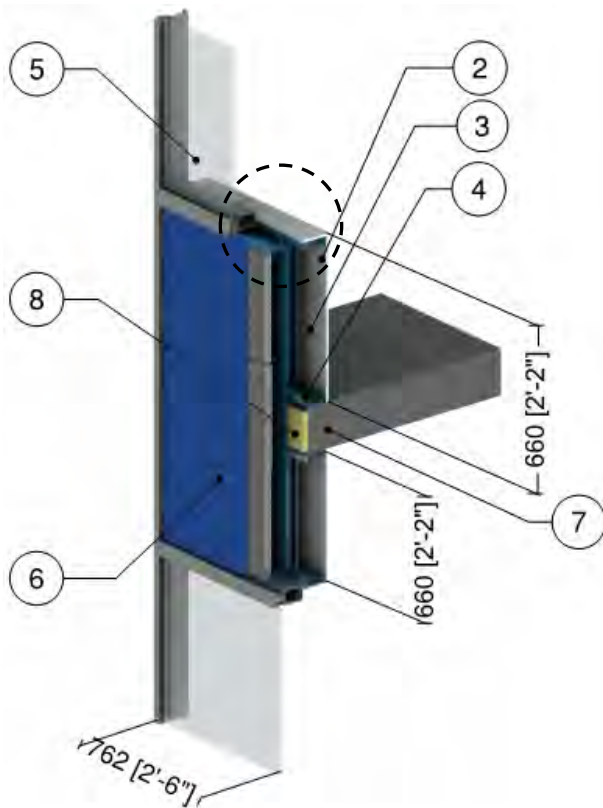

A1 – 1.5" (38 mm) AIM Adhered to Monolithic Glass

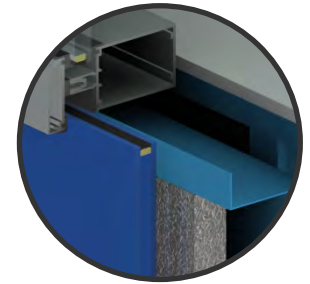

A2 – 1.5" (38 mm) AIM Adhered to Double Glazed IGU

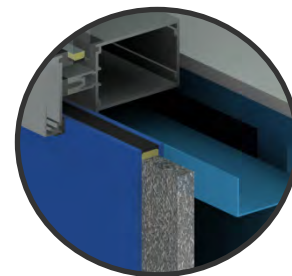

A3 – Aluminum Spacer, 0.75" (19 mm) AIM between Glass

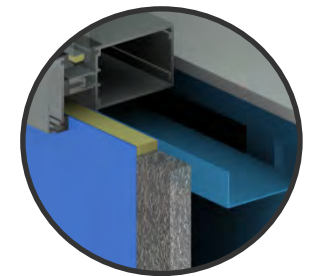

A4 – Rigid Insulation Spacer, 1" (25 mm) AIM between Metal Skins

ID	Component	Thickness Inches (mm)	Conductivity Btu-in / ft ² -hr-°F (W/m K)	Nominal Resistance hr-ft ² -°F/Btu (m ² K/W)	Density lb/ft ³ (kg/m ³)	Specific Heat Btu/lb-°F (J/kg K)
1	Interior Films ¹	-	-	R-0.6 to R-1.1 (0.12 to 0.20 RSI)	-	-
2	Gypsum Board	1/2" (13)	1.1 (0.16)	R-0.5 (0.08 RSI)	50 (800)	0.26 (1090)
3	Air in Stud Cavity	3 5/8" (92)	-	R-0.9 (0.16 RSI)	0.075 (1.2)	0.24 (1000)
4	1 5/8" x 1 5/8" Steel Studs (16"o.c.) with Top and Bottom Tracks	18 Gauge	430 (62)	-	489 (7830)	0.12 (500)
5	Conventional Curtain Wall Vision Section: double glazed IGU ²					
6	Conventional Curtain Wall Spandrel Section with varied insulation (see A1 to A4 above) ^{2,3}					
7	Concrete Slab	8" (203)	12.5 (1.8)	-	140 (2250)	0.20 (850)
8	Mineral Wool Insulation	1" (25)	0.24 (0.034)	R-4.2 (0.74 RSI)	4 (64)	0.20 (850)
9	Exterior Film ¹	-	-	R-0.2 (0.03 RSI)	-	-

¹ Value selected from table 1, p. 26.1 of 2009 ASHRAE Handbook – Fundamentals depending on surface orientation

² The thermal conductivity of air spaces within framing was found using ISO 100077-2

³ For a window to wall ratio of 50%

AIM = Architectural Insulation Module

Detail 2.1.5

Conventional Curtain Wall System with Vertical and Horizontal Pressure Plates and 5' x 5' Spandrel Section – Insulated Metal Backpan and Intermediate Floor Intersection

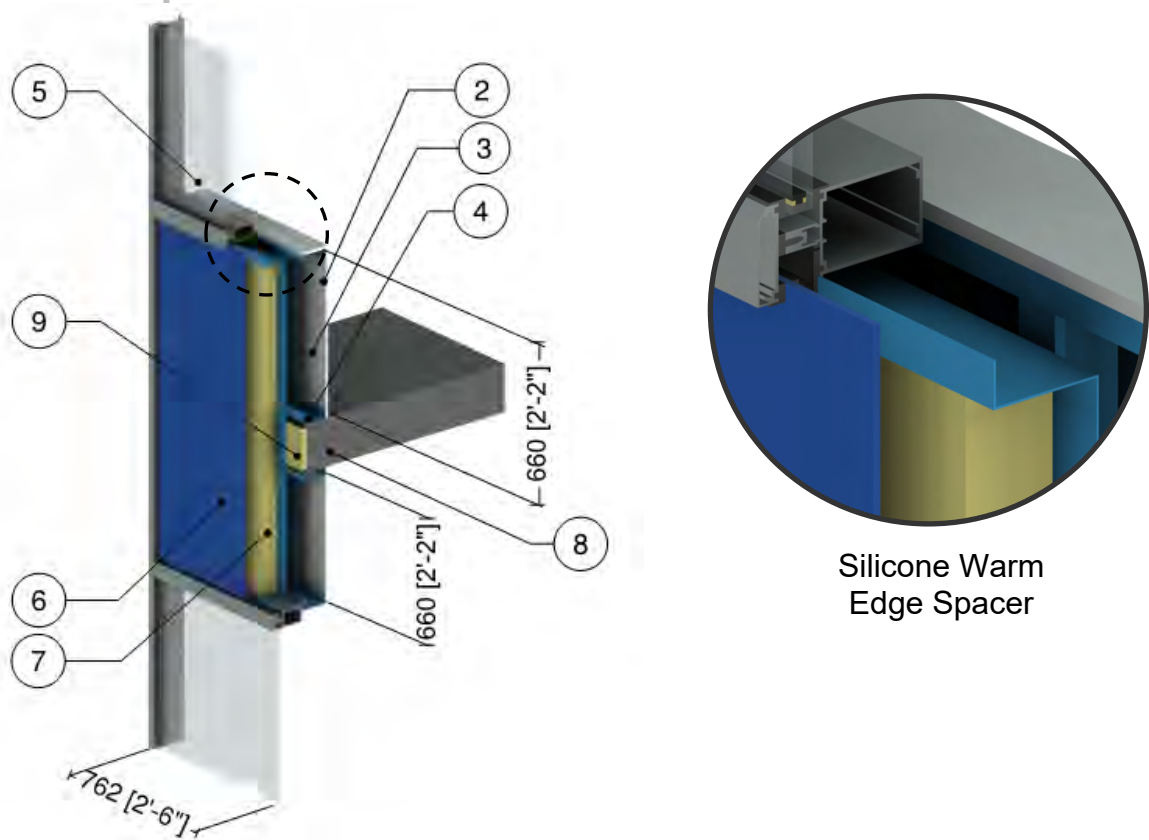

Silicone Warm Edge Spacer

ID	Component	Thickness Inches (mm)	Conductivity Btu-in / ft ² ·hr·°F (W/m K)	Nominal Resistance hr·ft ² ·°F/Btu (m ² K/W)	Density lb/ft ³ (kg/m ³)	Specific Heat Btu/lb·°F (J/kg K)
1	Interior Films ¹	-	-	R-0.6 to R-1.1 (0.12 to 0.20 RSI)	-	-
2	Gypsum Board	1/2" (13)	1.1 (0.16)	R-0.5 (0.08 RSI)	50 (800)	0.26 (1090)
3	Air in Stud Cavity	3 5/8" (92)	-	R-0.9 (0.16 RSI)	0.075 (1.2)	0.24 (1000)
4	1 5/8" x 1 5/8" Steel Studs (16"o.c.) with Top and Bottom Tracks	18 Gauge	430 (62)	-	489 (7830)	0.12 (500)
5	Conventional Curtain Wall Vision Section: double glazed IGU silicone warm edge spacer ²					
6	Conventional Curtain Wall Spandrel Section with Backpan Insulation ^{2,3}					
7	Backpan Insulation	4" (100)	0.24 (0.034)	R-16.8 (2.96 RSI)	4 (64)	0.20 (850)
8	Concrete Slab	8" (203)	12.5 (1.8)	-	140 (2250)	0.20 (850)
9	Mineral Wool Insulation	1" (25)	0.24 (0.034)	R-4.2 (0.74 RSI)	4 (64)	0.20 (850)
10	Exterior Film ¹	-	-	R-0.2 (0.03 RSI)	-	-

¹ Value selected from table 1, p. 26.1 of 2009 ASHRAE Handbook – Fundamentals depending on surface orientation

² The thermal conductivity of air spaces within framing was found using ISO 100077-2

³ For a window to wall ratio of 50%

Detail 2.1.6

Conventional Curtain Wall System with 5' x 5' Spandrel Section – Alternative Glazing Methods and Intermediate Floor Intersection

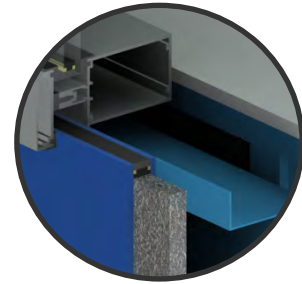
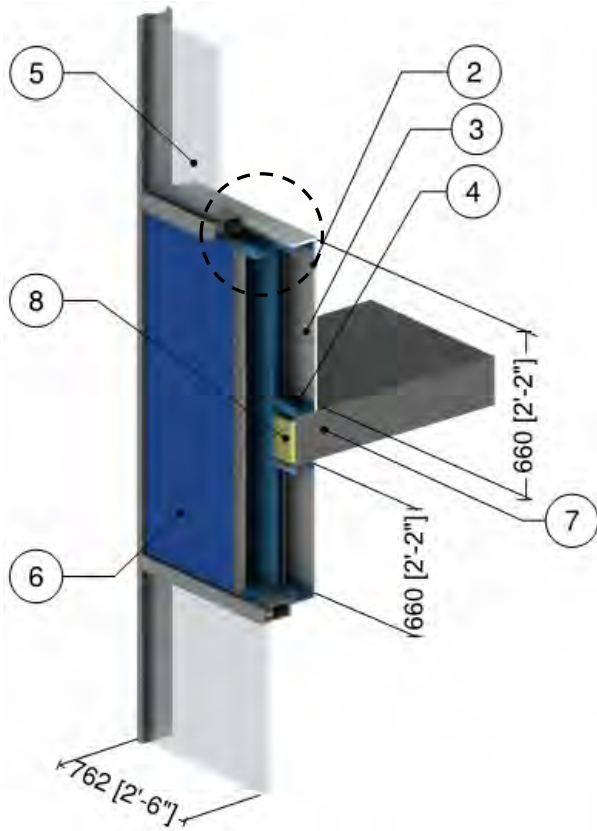

B1 – Vertical & Horizontal Pressure Plates, Warm Edge Spacer, 0.75" (19 mm) AIM between Glass

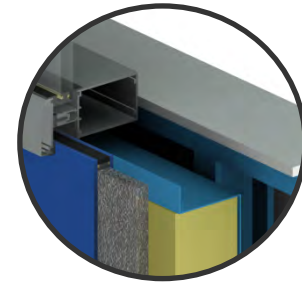

B2 – Vertical Structural Silicone & Horizontal Pressure Plates, Warm Edge Spacer, 0.75" (19 mm) AIM between Glass with 4" (100 mm) Backpan Insulation

ID	Component	Thickness Inches (mm)	Conductivity Btu-in / ft ² ·hr·°F (W/m K)	Nominal Resistance hr·ft ² ·°F/Btu (m ² K/W)	Density lb/ft ³ (kg/m ³)	Specific Heat Btu/lb·°F (J/kg K)
1	Interior Films ¹	-	-	R-0.6 to R-1.1 (0.12 to 0.20 RSI)	-	-
2	Gypsum Board	1/2" (13)	1.1 (0.16)	R-0.5 (0.08 RSI)	50 (800)	0.26 (1090)
3	Air in Stud Cavity	3 5/8" (92)	-	R-0.9 (0.16 RSI)	0.075 (1.2)	0.24 (1000)
4	1 5/8" x 1 5/8" Steel Studs (16"o.c.) with Top and Bottom Tracks	18 Gauge	430 (62)	-	489 (7830)	0.12 (500)
5	Conventional Curtain Wall Vision Section: double glazed IGU with silicone warm edge spacer ²					
6	Conventional Curtain Wall Spandrel Section with varied insulation (see B1 to B2 above) ^{2,3}					
7	Concrete Slab	8" (203)	12.5 (1.8)	-	140 (2250)	0.20 (850)
8	Mineral Wool Insulation	1" (25)	0.24 (0.034)	R-4.2 (0.74 RSI)	4 (64)	0.20 (850)
9	Exterior Film ¹	-	-	R-0.2 (0.03 RSI)	-	-

¹ Value selected from table 1, p. 26.1 of 2009 ASHRAE Handbook – Fundamentals depending on surface orientation

² The thermal conductivity of air spaces within framing was found using ISO 100077-2

³For a window to wall ratio of 50%

AIM = Architectural Insulation Module

Detail 2.1.7

Conventional Curtain Wall System with Vertical and Horizontal Pressure Plates and 5' x 5' Spandrel Section – Insulated Backpan and Improved Glazing at Intermediate Floor Intersection

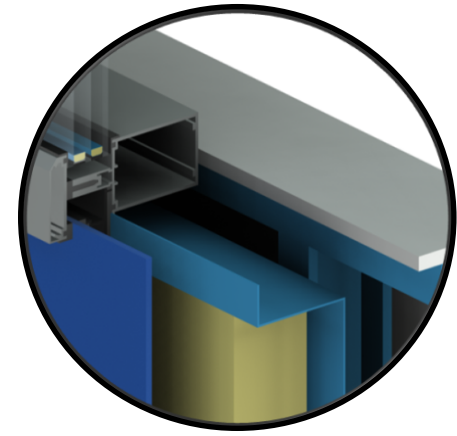
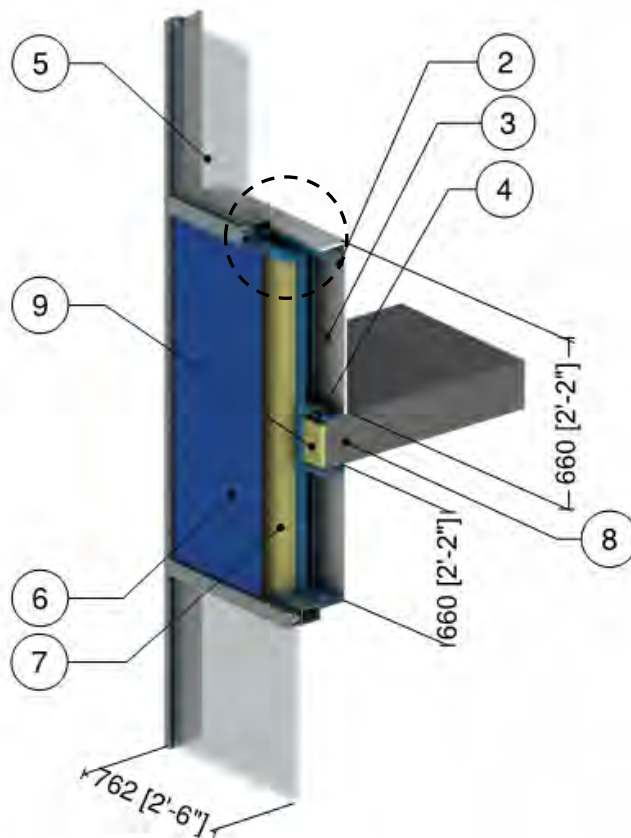

Triple Glazed IGU with Aluminum Spacer

ID	Component	Thickness Inches (mm)	Conductivity Btu-in / ft ² ·hr·°F (W/m K)	Nominal Resistance hr·ft ² ·°F/Btu (m ² K/W)	Density lb/ft ³ (kg/m ³)	Specific Heat Btu/lb·°F (J/kg K)
1	Interior Films ¹	-	-	R-0.6 to R-1.1 (0.12 to 0.20 RSI)	-	-
2	Gypsum Board	1/2" (13)	1.1 (0.16)	R-0.5 (0.08 RSI)	50 (800)	0.26 (1090)
3	Air in Stud Cavity	3 5/8" (92)	-	R-0.9 (0.16 RSI)	0.075 (1.2)	0.24 (1000)
4	1 5/8" x 1 5/8" Steel Studs (16"o.c.) with Top and Bottom Tracks	18 Gauge	430 (62)	-	489 (7830)	0.12 (500)
5	Conventional Curtain Wall Vision Section: triple glazed IGU with aluminum spacer ²					
6	Conventional Curtain Wall Spandrel Section with Backpan Insulation ^{2,3}					
7	Backpan Insulation	4" (100)	0.24 (0.034)	R-16.8 (2.96 RSI)	4 (64)	0.20 (850)
8	Concrete Slab	8" (203)	12.5 (1.8)	-	140 (2250)	0.20 (850)
9	Mineral Wool Insulation	1" (25)	0.24 (0.034)	R-4.2 (0.74 RSI)	4 (64)	0.20 (850)
10	Exterior Film ¹	-	-	R-0.2 (0.03 RSI)	-	-

¹ Value selected from table 1, p. 26.1 of 2009 ASHRAE Handbook – Fundamentals depending on surface orientation

² The thermal conductivity of air spaces within framing was found using ISO 100077-2

³For a window to wall ratio of 50%

Detail 2.1.8

Conventional Curtain Wall System with Vertical and Horizontal Pressure Plates and 5' x 5' Spandrel Section – AIM Applications and Improved Glazing at Intermediate Floor Intersection

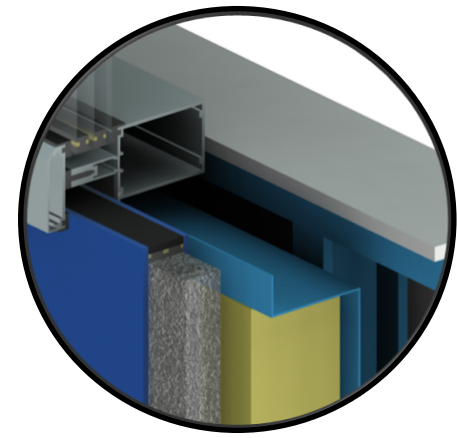
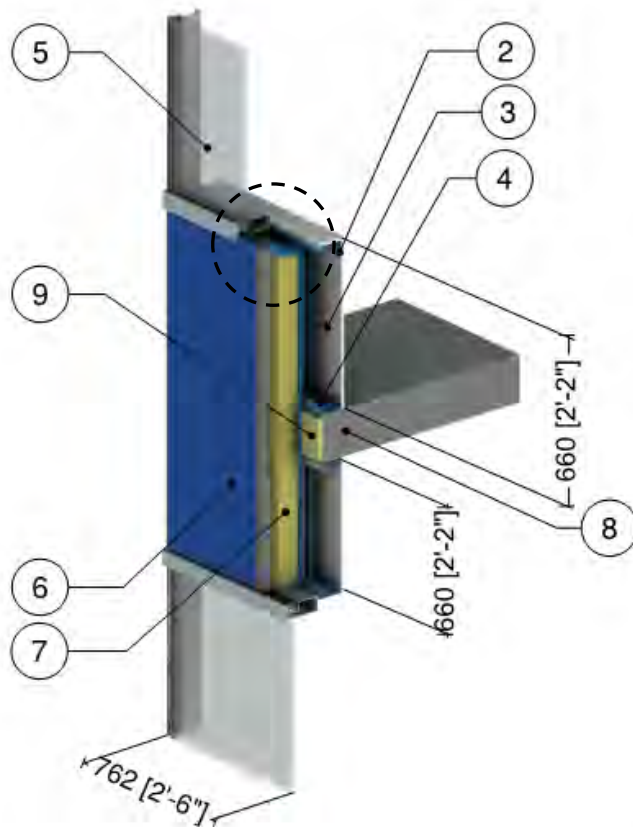

Triple Glazed IGU with Silicone Warm Edge Spacer

ID	Component	Thickness Inches (mm)	Conductivity Btu-in / ft ² ·hr·°F (W/m K)	Nominal Resistance hr·ft ² ·°F/Btu (m ² K/W)	Density lb/ft ³ (kg/m ³)	Specific Heat Btu/lb·°F (J/kg K)
1	Interior Films ¹	-	-	R-0.6 to R-1.1 (0.12 to 0.20 RSI)	-	-
2	Gypsum Board	1/2" (13)	1.1 (0.16)	R-0.5 (0.08 RSI)	50 (800)	0.26 (1090)
3	Air in Stud Cavity	3 5/8" (92)	-	R-0.9 (0.16 RSI)	0.075 (1.2)	0.24 (1000)
4	1 5/8" x 1 5/8" Steel Studs (16"o.c.) with Top and Bottom Tracks	18 Gauge	430 (62)	-	489 (7830)	0.12 (500)
5	Conventional Curtain Wall Vision Section: triple glazed IGU with silicone warm edge spacer ²					
6	Conventional Curtain Wall Spandrel Section with 1.5" (38) AIM between Glass and Backpan Insulation ^{2,3}					
7	Backpan Insulation	4" (100)	0.24 (0.034)	R-16.8 (2.96 RSI)	4 (64)	0.20 (850)
8	Concrete Slab	8" (203)	12.5 (1.8)	-	140 (2250)	0.20 (850)
9	Mineral Wool Insulation	1" (25)	0.24 (0.034)	R-4.2 (0.74 RSI)	4 (64)	0.20 (850)
10	Exterior Film ¹	-	-	R-0.2 (0.03 RSI)	-	-

¹ Value selected from table 1, p. 26.1 of 2009 ASHRAE Handbook – Fundamentals depending on surface orientation

² The thermal conductivity of air spaces within framing was found using ISO 100077-2

³For a window to wall ratio of 50%

AIM = Architectural Insulation Module

Detail 2.1.9

Conventional Curtain Wall System with Vertical and Horizontal Pressure Plates – Intermediate Mullion and 5' x 5' Spandrel Section – Insulated Backpan and Intermediate Floor Intersection

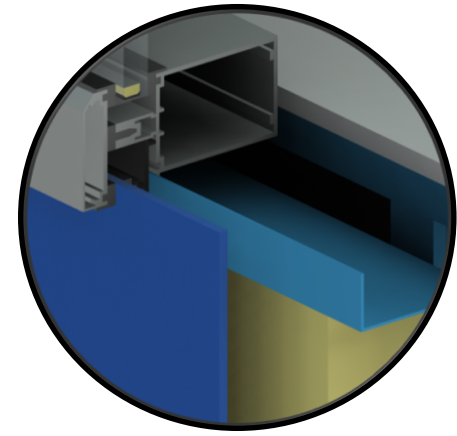
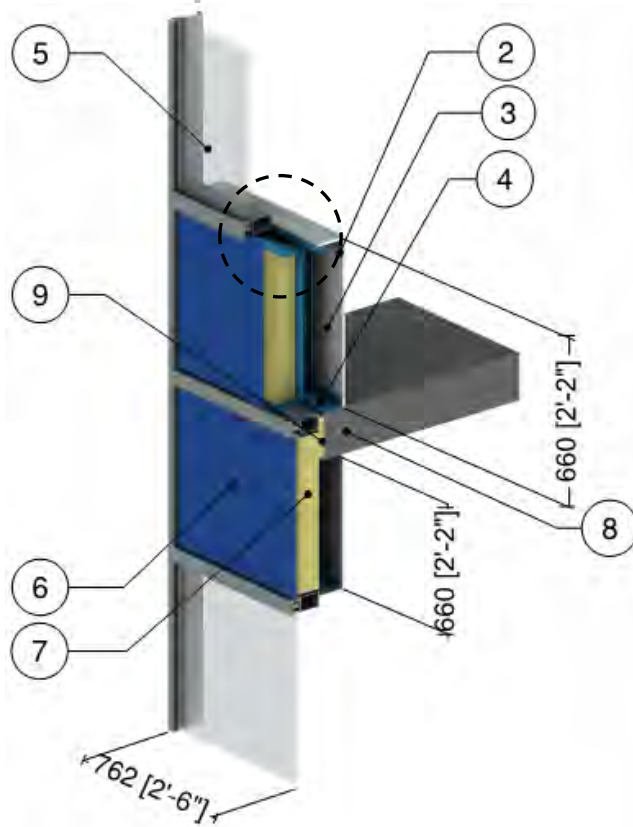

Double Glazed IGU
with Aluminum Spacer

ID	Component	Thickness Inches (mm)	Conductivity Btu-in / ft ² ·hr·°F (W/m K)	Nominal Resistance hr·ft ² ·°F/Btu (m ² K/W)	Density lb/ft ³ (kg/m ³)	Specific Heat Btu/lb·°F (J/kg K)
1	Interior Films ¹	-	-	R-0.6 to R-1.1 (0.12 to 0.20 RSI)	-	-
2	Gypsum Board	1/2" (13)	1.1 (0.16)	R-0.5 (0.08 RSI)	50 (800)	0.26 (1090)
3	Air in Stud Cavity	3 5/8" (92)	-	R-0.9 (0.16 RSI)	0.075 (1.2)	0.24 (1000)
4	1 5/8" x 1 5/8" Steel Studs (16"o.c.) with Top and Bottom Tracks	18 Gauge	430 (62)	-	489 (7830)	0.12 (500)
5	Conventional Curtain Wall Vision Section: double glazed IGU with aluminum spacer ²					
6	Conventional Curtain Wall Spandrel with Intermediate Mullion Section and Backpan Insulation ^{2,3}					
7	Backpan Insulation	4" (100)	0.24 (0.034)	R-16.8 (2.96 RSI)	4 (64)	0.20 (850)
8	Concrete Slab	8" (203)	12.5 (1.8)	-	140 (2250)	0.20 (850)
9	Mineral Wool Insulation	1" (25)	0.24 (0.034)	R-4.2 (0.74 RSI)	4 (64)	0.20 (850)
10	Exterior Film ¹	-	-	R-0.2 (0.03 RSI)	-	-

¹ Value selected from table 1, p. 26.1 of 2009 ASHRAE Handbook – Fundamentals depending on surface orientation

² The thermal conductivity of air spaces within framing was found using ISO 100077-2

³ For a window to wall ratio of 50%

Detail 2.1.10

Conventional Curtain Wall System with Vertical and Horizontal Pressure Plates – Intermediate Mullion and 5' x 5' Spandrel Section – AIM Applications and Intermediate Floor Intersection

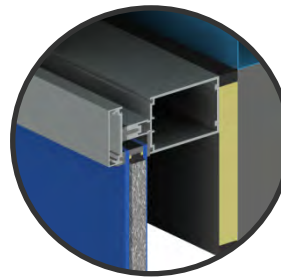
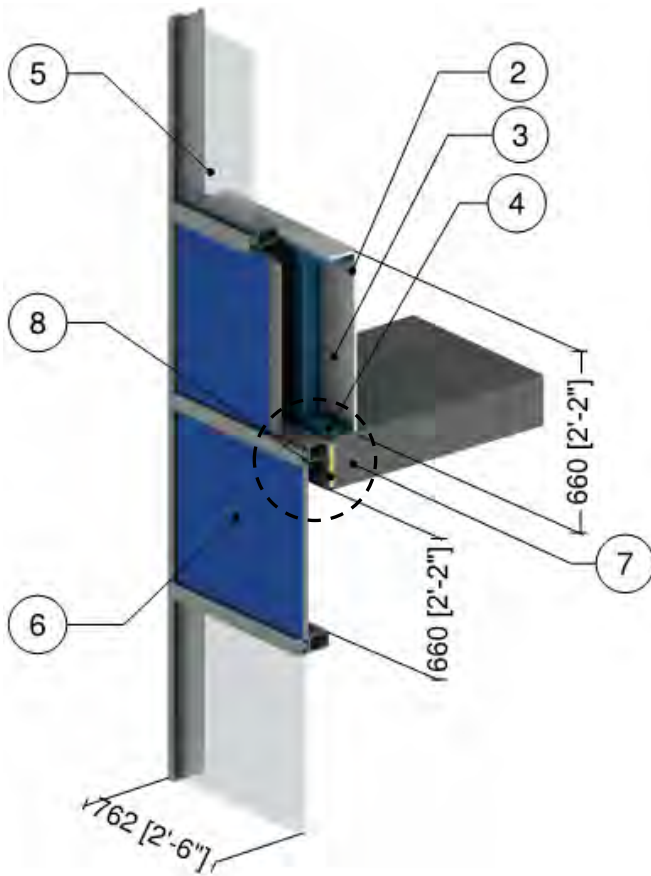

D1 – Vertical & Horizontal Pressure Plates, Warm Edge Spacer, 0.75" (19 mm) AIM Between Glass

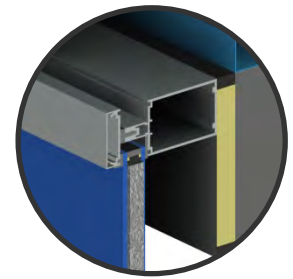

D2 – Vertical Structural Silicone & Horizontal Pressure Plates, Warm Edge Spacer, 0.75" (19 mm) AIM between Glass

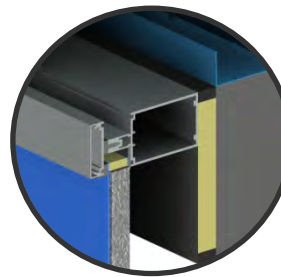

D3 – Vertical Structural Silicone & Horizontal Pressure Plates, Rigid Insulation Spacer, 1" (25 mm) AIM between Metal Skins

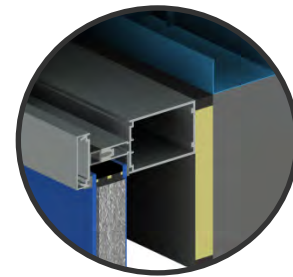

D4 – Vertical Structural Silicone & Horizontal Pressure Plates, Warm Edge Spacer, 1.5" (38 mm) AIM between Glass

ID	Component	Thickness Inches (mm)	Conductivity Btu-in / ft ² -hr-°F (W/m K)	Nominal Resistance hr-ft ² -°F/Btu (m ² K/W)	Density lb/ft ³ (kg/m ³)	Specific Heat Btu/lb-°F (J/kg K)
1	Interior Films ¹	-	-	R-0.6 to R-1.1 (0.12 to 0.20 RSI)	-	-
2	Gypsum Board	1/2" (13)	1.1 (0.16)	R-0.5 (0.08 RSI)	50 (800)	0.26 (1090)
3	Air in Stud Cavity	3 5/8" (92)	-	R-0.9 (0.16 RSI)	0.075 (1.2)	0.24 (1000)
4	1 5/8" x 1 5/8" Steel Studs (16"o.c.) with Top and Bottom Tracks	18 Gauge	430 (62)	-	489 (7830)	0.12 (500)
5	Conventional Curtain Wall Vision Section: double glazed (D1 to D3) or Triple Glazed (D4) IGU ²					
6	Conventional Curtain Wall Spandrel Section with varied insulation (see D1 to D4 above) ^{2,3}					
7	Concrete Slab	8" (203)	12.5 (1.8)	-	140 (2250)	0.20 (850)
8	Mineral Wool Insulation	1" (25)	0.24 (0.034)	R-4.2 (0.74 RSI)	4 (64)	0.20 (850)
9	Exterior Film ¹	-	-	R-0.2 (0.03 RSI)	-	-

¹ Value selected from table 1, p. 26.1 of 2009 ASHRAE Handbook – Fundamentals depending on surface orientation

² The thermal conductivity of air spaces within framing was found using ISO 100077-2

³ For a window to wall ratio of 50%

AIM = Architectural Insulation Module

Detail 2.1.11

Conventional Curtain Wall System with Insulated Spandrel Panel and 3 5/8" x 1 5/8" Steel Stud (16" o.c.) – Slab Intersection & Spray Foam Insulation in Stud Cavity with Thermal Break Under Stud Cavity and at Anchors

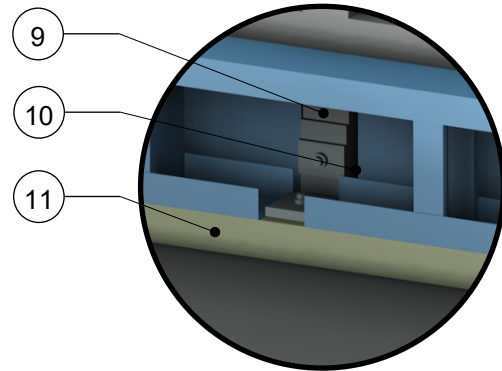
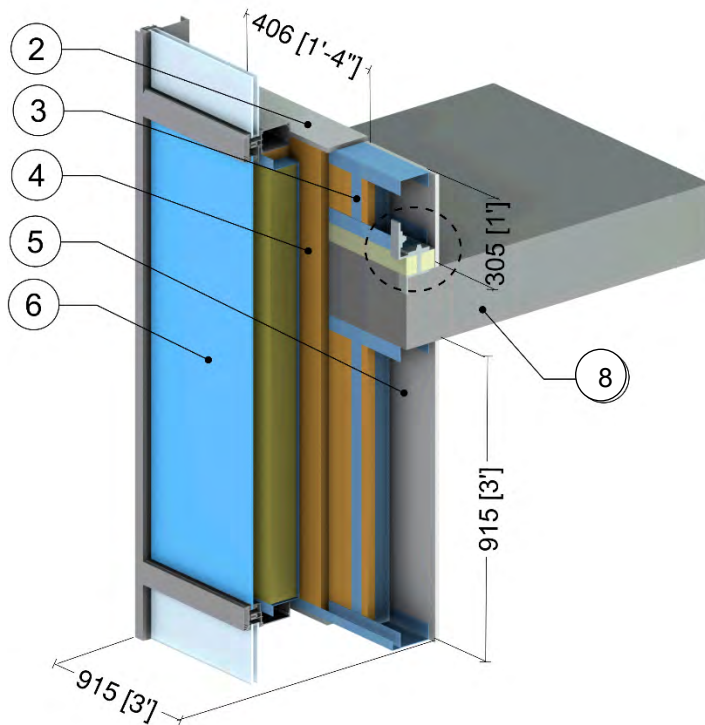

Anchor Detail

ID	Component	Thickness Inches (mm)	Conductivity Btu-in / ft ² ·hr·°F (W/m K)	Nominal Resistance hr·ft ² ·°F/Btu (m ² K/W)	Density lb/ft ³ (kg/m ³)	Specific Heat Btu/lb·°F (J/kg K)
1	Interior Film ¹	-	-	R-0.6 to R-0.9 (0.11 to 0.16 RSI)	-	-
2	Gypsum Board	1/2" (13)	1.1 (0.16)	R-0.5 (0.08 RSI)	50 (800)	0.26 (1090)
3	3 5/8" x 1 5/8" Steel Studs with Top and Bottom Tracks	18 Gauge	430 (62)	-	489 (7830)	0.12 (500)
4	Spray Foam Insulation	2" (51)	0.17 (0.025)	-	2.4 (39)	0.35 (1470)
5	Air in Stud Cavity	2 5/8" (67)	-	R-0.9 (0.16 RSI)	0.075 (1.2)	0.24 (1000)
6	Conventional curtain wall system with insulated back pan (Pressure plates with minimal thermal break) ²					
7	Backpan Insulation	-	-	R-15.0 (2.64 RSI)	1.8 (28)	0.29 (1220)
8	Concrete Slab	8" (203)	12.5 (1.8)	-	140 (2250)	0.20 (850)
9	Steel Anchor at vertical mullions	-	347 (50)	-	489 (7830)	0.12 (500)
10	Armatherm FRR	3/8" (10)	1.4 (0.20)	-	85 (5.3)	-
11	Armatherm 500	2" (50)	0.32 (0.05)	R-6.2 (1.09 RSI)	-	-
12	Exterior Film ¹	-	-	R-0.2 (0.03 RSI)	-	-

¹ Value selected from table 1, p. 26.1 of 2009 ASHRAE Handbook – Fundamentals depending on surface orientation & surface emissivity. Window values supplemented by ISO 1007-2, Annex B.

² The thermal conductivity of air spaces was found using ISO 100077-2

Detail 2.1.12

Conventional Curtain Wall System with Insulated Spandrel Panel and 3 5/8" x 1 5/8" Steel Studs (16" o.c.) – Slab Intersection & No Metal Back Pan

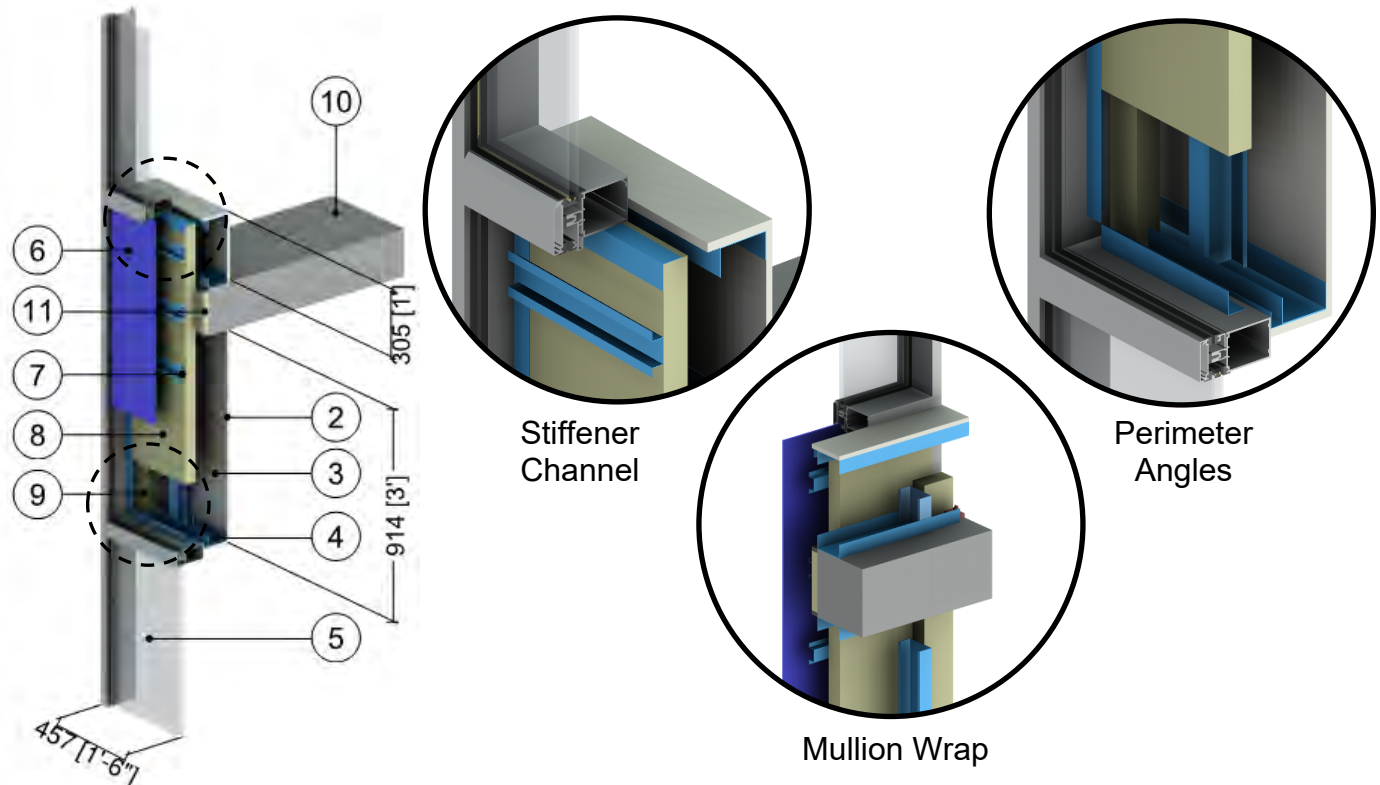

ID	Component	Thickness Inches (mm)	Conductivity Btu-in / ft ² -hr-°F (W/m K)	Nominal Resistance hr-ft ² -°F/Btu (m ² K/W)	Density lb/ft ³ (kg/m ³)	Specific Heat Btu/lb-°F (J/kg K)
1	Interior Film ¹	-	-	R-0.6 to R-1.1 (0.11 to 0.20 RSI)	-	-
2	Gypsum Board	1/2" (13)	1.1 (0.16)	R-0.5 (0.08 RSI)	50 (800)	0.26 (1090)
3	Air in Stud Cavity	3 5/8" (92)	-	R-0.9 (RSI-0.16)	0.075 (1.2)	0.24 (1000)
4	3 5/8" x 1 5/8" Steel Studs with Top and Bottom Tracks	18 Gauge	430 (62)	-	489 (7830)	0.12 (500)
5	Conventional Curtain Wall Vision Section: double glazed IGU with warm edge spacer ²					
6	Conventional Curtain Wall Spandrel Section with Spandrel Insulation ²					
7	Spandrel Insulation Stiffeners	22 Gauge	430 (62)	-	489 (7830)	0.12 (500)
8	Spandrel Insulation	2" (51)	-	R-8.4 (1.48 RSI)	1.8 (28)	0.29 (1220)
9	Mullion Wrap Insulation	With and Without	-	R-8.4 (1.48 RSI)	1.8 (28)	0.29 (1220)
10	Concrete Slab	8" (203)	12.5 (1.8)	-	140 (2250)	0.20 (850)
11	Mineral Wool Insulation	1"	0.24 (0.034)	-	1.8 (28)	0.29 (1220)
12	Exterior Film ¹	-	-	R-0.2 (0.03 RSI)	-	-

¹ Value selected from table 1, p. 26.1 of 2009 ASHRAE Handbook – Fundamentals depending on surface orientation

² The thermal conductivity of air spaces within framing was found using ISO 100077-2

Detail 2.1.13

Conventional Curtain Wall System with Insulated Spandrel Panel and 3 5/8" x 1 5/8" Steel Studs (16" o.c.) – Slab Intersection & Metal Back Pan Connected to Side of Frame

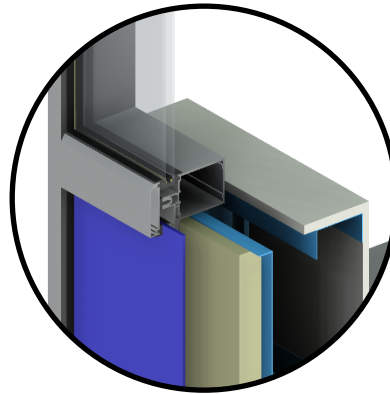
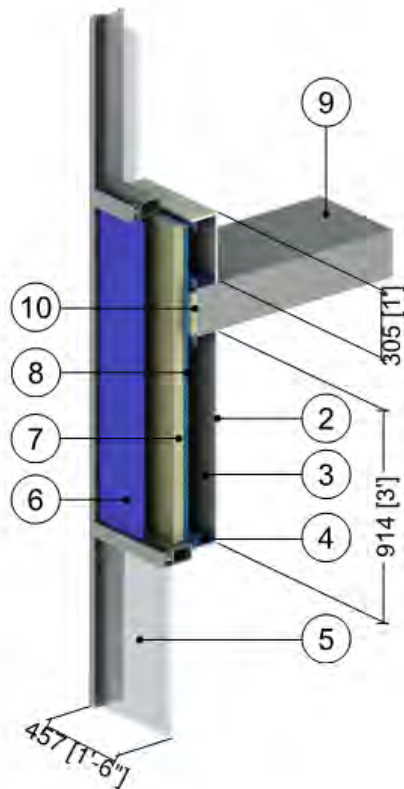

Metal Back Pan
Connected Inset in
Frame

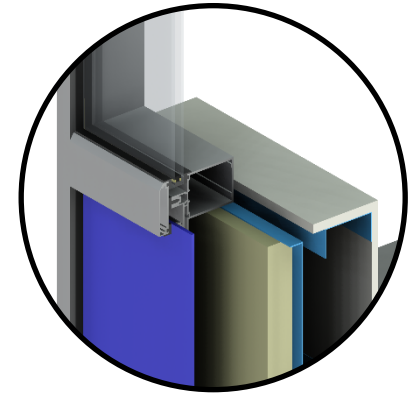

Metal Back Pan
Connected at
Interior of Frame

ID	Component	Thickness Inches (mm)	Conductivity Btu-in / ft ² -hr-°F (W/m K)	Nominal Resistance hr-ft ² -°F/Btu (m ² K/W)	Density lb/ft ³ (kg/m ³)	Specific Heat Btu/lb-°F (J/kg K)
1	Interior Film ¹	-	-	R-0.6 to R-1.1 (0.11 to 0.20 RSI)	-	-
2	Gypsum Board	1/2" (13)	1.1 (0.16)	R-0.5 (0.08 RSI)	50 (800)	0.26 (1090)
3	Air in Stud Cavity	3 5/8" (92)	-	R-0.9 (RSI-0.16)	0.075 (1.2)	0.24 (1000)
4	3 5/8" x 1 5/8" Steel Studs with Top and Bottom Tracks	18 Gauge	430 (62)	-	489 (7830)	0.12 (500)
5	Conventional Curtain Wall Vision Section: double glazed IGU with warm edge spacer ²					
6	Conventional Curtain Wall Spandrel Section with Insulated Metal Back Pan ²					
7	Backpan Insulation	Varies	-	R-8.4 to R-16.8 (1.48 to 2.96 RSI)	1.8 (28)	0.29 (1220)
8	Metal Back Pan	22 Gauge	430 (62)	-	489 (7830)	0.12 (500)
9	Concrete Slab	8" (203)	12.5 (1.8)	-	140 (2250)	0.20 (850)
10	Mineral Wool Insulation	1"	0.24 (0.034)	-	1.8 (28)	0.29 (1220)
11	Exterior Film ¹	-	-	R-0.2 (0.03 RSI)	-	-

¹ Value selected from table 1, p. 26.1 of 2009 ASHRAE Handbook – Fundamentals depending on surface orientation

² The thermal conductivity of air spaces within framing was found using ISO 100077-2

Detail 2.1.14

Conventional Curtain Wall System with Vertical and Horizontal Pressure Plates and 5' x 5' Spandrel Section – Owens Corning Thermafiber Impasse System and Intermediate Floor Intersection

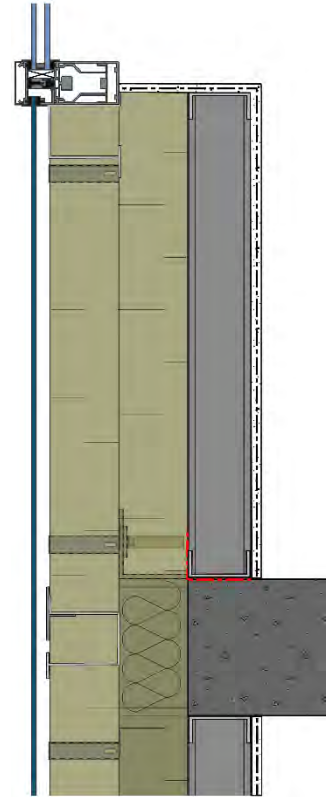
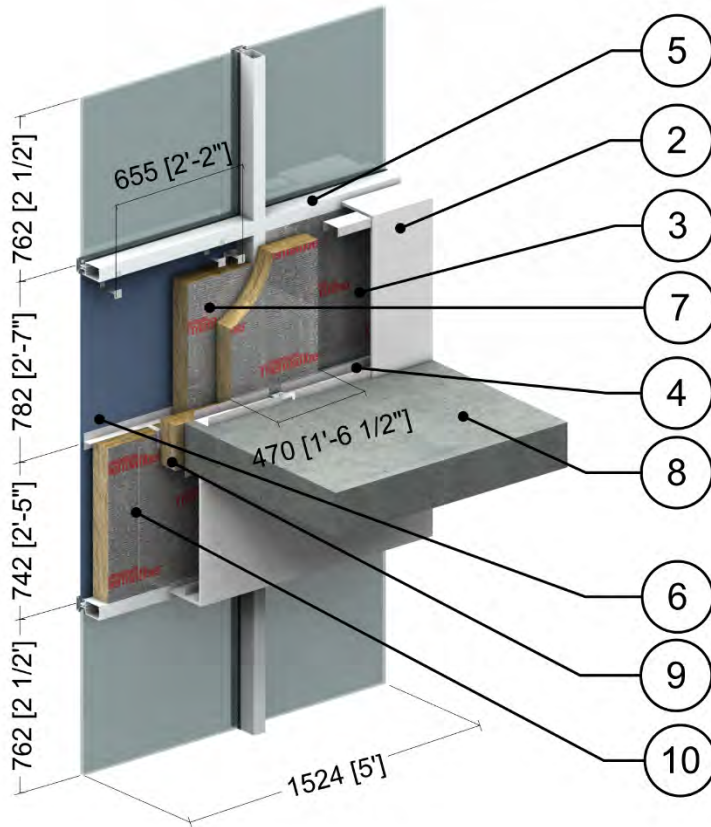

ID	Component	Thickness Inches (mm)	Conductivity Btu-in / ft ² ·hr·°F (W/m K)	Nominal Resistance hr·ft ² ·°F/Btu (m ² K/W)	Density lb/ft ³ (kg/m ³)
1	Interior Films ¹	-	-	R-0.6 (0.12 RSI) to R-1.1 (0.20 RSI)	-
2	Gypsum Board	1/2" (13)	1.1 (0.16)	R-0.5 (0.08 RSI)	50 (800)
3	Air in Stud Cavity	1 5/8" (41)	-	R-0.9 (0.16 RSI)	0.075 (1.2)
4	1 5/8" x 1 5/8" Steel Studs (16"o.c.) with Top and Bottom Tracks	18 Gauge	430 (62)	-	489 (7830)
5	5' (1.5m) x 5' (1.5m) Aluminum window: thermally broken, double glazed IGU ² U _{IGU} = 0.32 BTU/hr.ft ² ·°F (1.82 W/m ² K)				
6	5' (1.5m) x 5' (1.5m) Conventional Curtain Wall Spandrel Section with Thermafiber Impasse System ²				
7	Thermafiber RainBarrier 45 Mineral Wool Semi Rigid Spandrel Insulation	4" (102)	0.24 (0.034)	R-16.8 (2.96 RSI)	4.5 (72)
8	Concrete Slab	8" (203)	12.5 (1.8)	-	140 (2250)
9	Safing Mineral Wool Insulation	3" (76)	0.24 (0.034)	-	4.5 (72)
10	Thermafiber RainBarrier 45 Mineral Wool Semi Rigid Mullion Cover Insulation	2" (51)	0.24 (0.034)	R-8.4 (1.48 RSI)	4.5 (72)
11	Exterior Film ¹	-	-	R-0.2 (0.03 RSI)	-

¹ Value selected from table 1, p. 26.1 of 2009 ASHRAE Handbook – Fundamentals depending on surface orientation

² The thermal conductivity of air spaces within framing was found using ISO 100077-2

Detail 2.2.1

Conventional Curtain Wall System with Insulated Spandrel Panel & 3 5/8" x 1 5/8" Steel Stud (16" o.c.) – Un-insulated Concrete with Spandrel & Roof Intersection

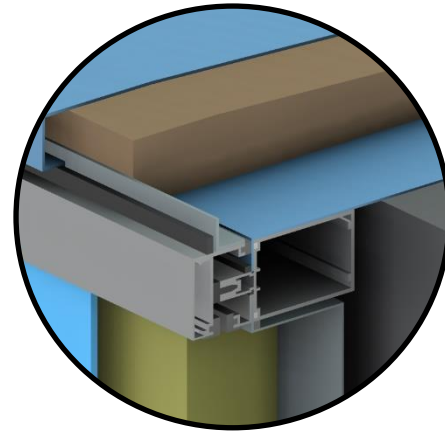
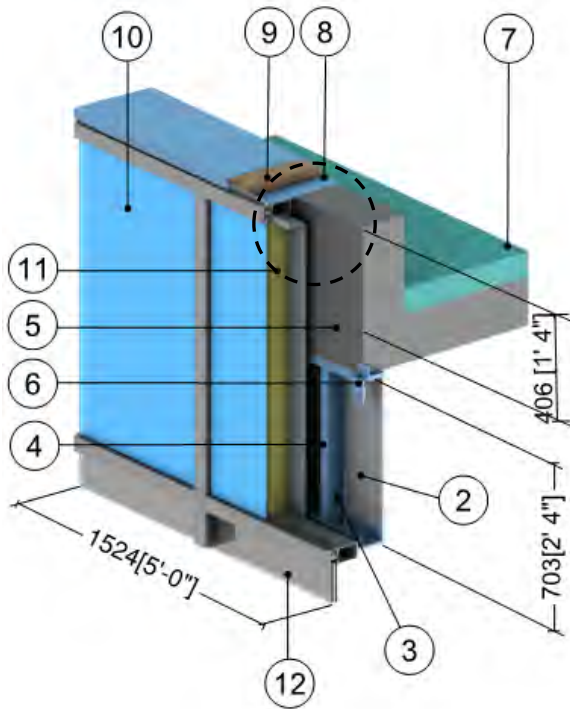

Parapet Cap Detail

ID	Component	Thickness Inches (mm)	Conductivity Btu-in / ft ² ·hr·°F (W/m K)	Nominal Resistance hr·ft ² ·°F/Btu (m ² K/W)	Density lb/ft ³ (kg/m ³)	Specific Heat Btu/lb·°F (J/kg K)
1	Interior Film ¹	-	-	R-0.6 to R-1.1 (0.11 to 0.20 RSI)	-	-
2	Gypsum Board	1/2" (13)	1.1 (0.16)	R-0.5 (0.08 RSI)	50 (800)	0.26 (1090)
3	Air in Stud Cavity	3 5/8" (92)	-	R-0.9 (0.16 RSI)	0.075 (1.2)	0.24 (1000)
4	3 5/8" x 1 5/8" Steel Studs with Top and Bottom Tracks	18 Gauge	430 (62)	-	489 (7830)	0.12 (500)
5	Concrete Slab & Parapet	8" (203)	12.5 (1.8)	R-0.6 (0.11 RSI)	140 (2250)	0.20 (850)
6	Anchor at Vertical Mullions	-	347 (50)	-	489 (7830)	0.12 (500)
7	Roof Insulation	4" (102)	-	R-20 (3.5 RSI)	1.8 (28)	0.29 (1220)
8	Parapet Flashing	18 Gauge	430 (62)	-	489 (7830)	0.12 (500)
9	Wood Blocking	-	0.69 (0.10)	-	27.8 (445)	0.45 (1880)
10	Conventional Curtain Wall Spandrel System with Insulated Backpan: minimal thermally broken frame ²					
11	Backpan Insulation	Varies	0.24 (0.034)	R-8.4 to R-16.8 (1.48 to 2.96 RSI)	4 (64)	0.20 (850)
12	Conventional Curtain Wall Vision System : minimal thermally broken frame ² , double glazed IGU U _{COG} = 0.32 BTU/hr·ft ² ·°F (1.82 W/m ² K)					
13	Flashing & roof finish material are incorporated into exterior heat transfer coefficient					
14	Exterior Film ¹	-	-	R-0.2 (0.03 RSI)	-	-

¹ Value selected from table 1, p. 26.1 of 2009 ASHRAE Handbook – Fundamentals depending on surface orientation

² The thermal conductivity of air spaces within framing was found using ISO 100077-2

Detail 2.2.2

Conventional Curtain Wall System – Insulated Spandrel & Roof Intersection

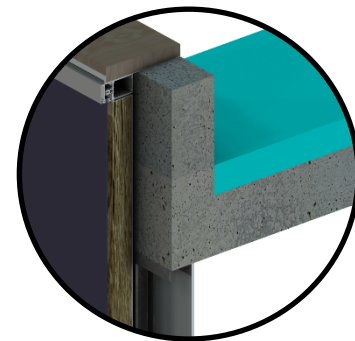
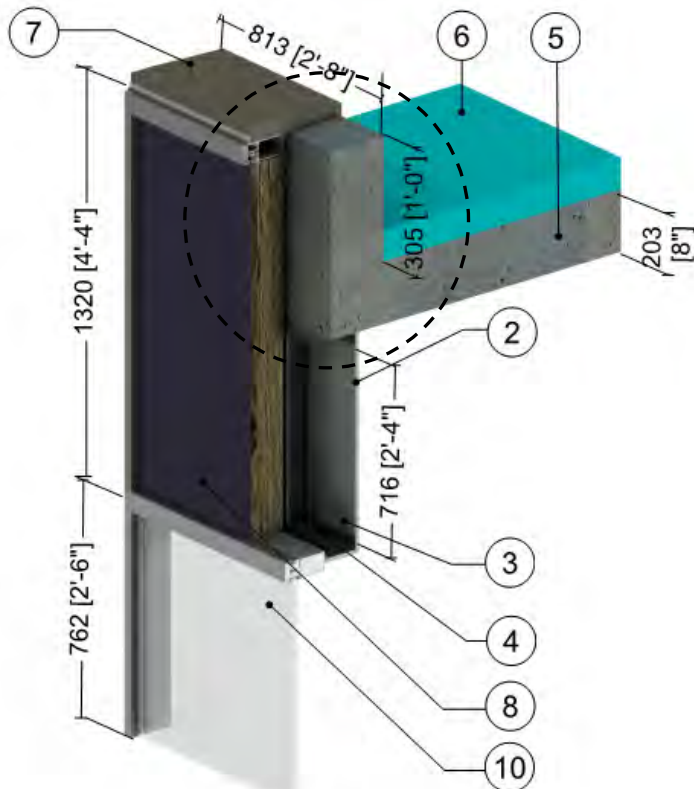

Without Aerogel Detail

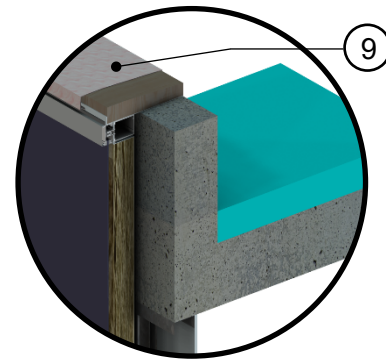

With Aerogel Detail

ID	Component	Thickness Inches (mm)	Conductivity Btu-in / ft ² -hr-°F (W/m K)	Nominal Resistance hr-ft ² -°F/Btu (m ² K/W)	Density lb/ft ³ (kg/m ³)	Specific Heat Btu/lb-°F (J/kg K)
1	Interior Films ¹	-	-	R-0.6 (0.12 RSI) to R-0.9 (0.16 RSI)	-	-
2	Gypsum Board	1/2" (13)	1.1 (0.16)	R-0.5 (0.08 RSI)	50 (800)	0.26 (1090)
3	Air in Stud Cavity	3 5/8" (92)	-	R-0.9 (0.16 RSI)	0.075 (1.2)	0.24 (1000)
4	3 5/8" x 1 5/8" Steel Studs with Top and Bottom Tracks	18 Gauge	430 (62)	-	489 (7830)	0.12 (500)
5	Concrete Slab & Parapet	8" (203)	12.5 (1.8)	R-0.6 (0.11 RSI)	140 (2250)	0.20 (850)
6	Roof Insulation	4" (102)	-	R-20 (3.5 RSI)	1.8 (28)	0.29 (1220)
7	Wood Blocking	-	0.69 (0.10)	-	31 (500)	0.45 (1880)
8	Conventional Curtain Wall Spandrel System with Insulated Backpan: minimal thermally broken frame ²					
9	Aerogel Blanket	0.4" (10)	0.086 (0.015)	R-3.8 (0.67 RSI)	-	-
10	Conventional Curtain Wall Vision System : minimal thermally broken frame ² , double glazed IGU U _{IGU} = 0.32 BTU/hr-ft ² -°F (1.82 W/m ² K)					
11	Exterior Film ¹	-	-	R-0.2 (0.03 RSI)	-	-

¹ Value selected from table 1, p. 26.1 of 2009 ASHRAE Handbook – Fundamentals depending on surface orientation

² The thermal conductivity of air spaces within framing was found using ISO 100077-2

Detail 2.2.3

Conventional Curtain Wall System with Insulated Spandrel Panel and 3 5/8" x 1 5/8" Steel Stud (16" o.c.) – Concrete Parapet Roof Intersection & Spray Foam Insulation in Stud Cavity

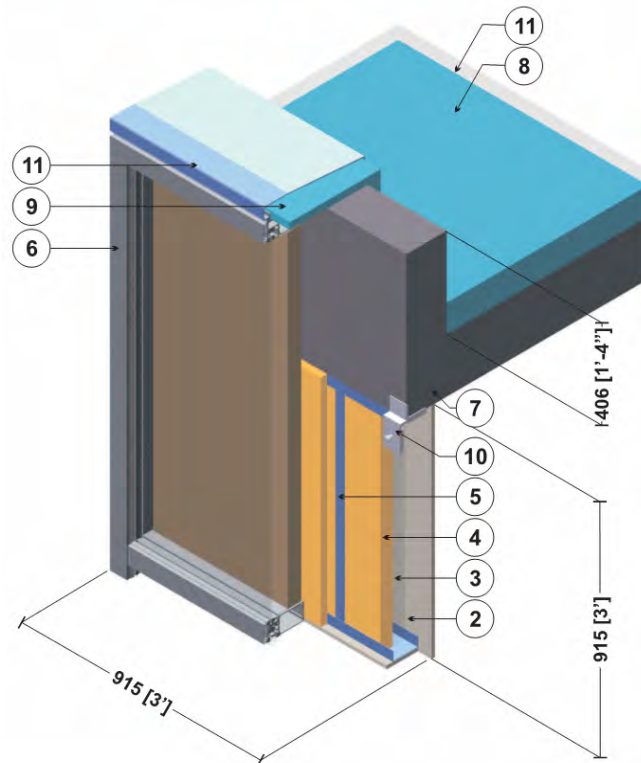

ID	Component	Thickness Inches (mm)	Conductivity Btu·in / ft ² ·hr·°F (W/m K)	Nominal Resistance hr·ft ² ·°F/Btu (m ² K/W)	Density lb/ft ³ (kg/m ³)	Specific Heat Btu/lb·°F (J/kg K)
1	Interior Film ¹	-	-	R-0.6 to R-0.7 (0.11 to 0.12 RSI)	-	-
2	Gypsum Board	1/2" (13)	1.1 (0.16)	R-0.5 (0.08 RSI)	50 (800)	0.26 (1090)
3	Air in Stud Cavity	2 5/8" (67)	-	R-0.9 (0.16 RSI)	0.075 (1.2)	0.24 (1000)
4	Spray Foam Insulation	2" (51)	0.17 (0.025)	-	2.8 (39)	0.35 (1470)
5	3 5/8" x 1 5/8" Steel Studs with Top and Bottom Tracks	18 Gauge	430 (62)	-	489 (7830)	0.12 (500)
6	Conventional curtain wall system with insulated back pan (Pressure plates with minimal thermal break) ²					
7	Concrete Slab & Parapet	8" (203)	12.5 (1.8)	-	140 (2250)	0.20 (850)
8	Roof Insulation	4" (102)	-	R-20 (3.5 RSI)	1.8 (28)	0.29 (1220)
9	Parapet Insulation	1" (25)	-	R-5 (0.88 RSI)	1.8 (28)	0.29 (1220)
10	Steel Anchor at vertical mullions	-	347 (50)	-	489 (7830)	0.12 (500)
11	Metal cap flashing/ finish roof materials is incorporated into exterior heat transfer coefficient					
12	Exterior Film ¹	-	-	R-0.2 (0.03 RSI)	-	-

¹ Value selected from table 1, p. 26.1 of 2009 ASHRAE Handbook – Fundamentals depending on surface orientation & surface emissivity. Window values supplemented by ISO 1007-2, Annex B.

² The thermal conductivity of air spaces within curtain wall framing was found using ISO 10077-2

Detail 2.2.4

Conventional Curtain Wall System with Insulated Spandrel Panel & 3 5/8" x 1 5/8" Steel Stud (16" o.c.) – Insulated Concrete with Spandrel & Roof Intersection

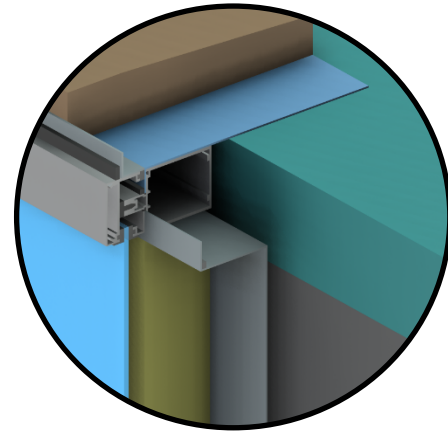
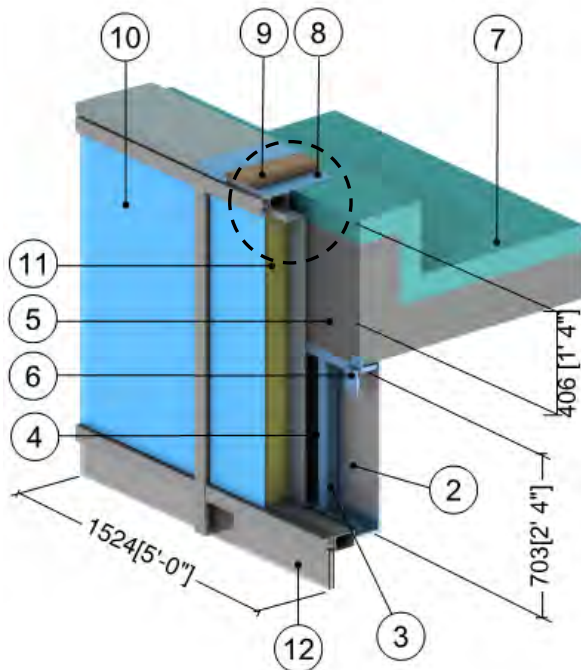

Parapet Cap Detail

ID	Component	Thickness Inches (mm)	Conductivity Btu-in / ft ² ·hr·°F (W/m K)	Nominal Resistance hr·ft ² ·°F/Btu (m ² K/W)	Density lb/ft ³ (kg/m ³)	Specific Heat Btu/lb·°F (J/kg K)
1	Interior Film ¹	-	-	R-0.6 to R-1.1 (0.12 to 0.20 RSI)	-	-
2	Gypsum Board	1/2" (13)	1.1 (0.16)	R-0.5 (0.08 RSI)	50 (800)	0.26 (1090)
3	Air in Stud Cavity	3 5/8" (92)	-	R-0.9 (0.16 RSI)	0.075 (1.2)	0.24 (1000)
4	3 5/8" x 1 5/8" Steel Studs with Top and Bottom Tracks	18 gauge	430 (62)	-	489 (7830)	0.12 (500)
5	Concrete Slab & Parapet	8" (203)	12.5 (1.8)	R-0.6 (0.11 RSI)	140 (2250)	0.20 (850)
6	Anchor at Vertical Mullions	-	347 (50)	-	489 (7830)	0.12 (500)
7	Roof Insulation	4" (102)	-	R-20 (3.5 RSI)	1.8 (28)	0.29 (1220)
8	Parapet Flashing	18 Gauge	430 (62)	-	489 (7830)	0.12 (500)
9	Wood Blocking		0.69 (0.10)	-	27.8 (445)	0.45 (1880)
10	Conventional Curtain Wall Spandrel System with Insulated Backpan: minimal thermally broken frame ²					
11	Backpan Insulation	Varies	0.24 (0.034)	R-8.4 to R-16.8 (1.48 to 2.96 RSI)	4 (64)	0.20 (850)
12	Conventional Curtain Wall Vision System : minimal thermally broken frame ² , double glazed IGU U _{COG} = 0.32 BTU/hr·ft ² ·°F (1.82 W/m ² K)					
13	Flashing & roof finish material are incorporated into exterior heat transfer coefficient					
14	Exterior Film ¹	-	-	R-0.2 (0.03 RSI)	-	-

¹ Value selected from table 1, p. 26.1 of 2009 ASHRAE Handbook – Fundamentals depending on surface orientation

² The thermal conductivity of air spaces within framing was found using ISO 100077-2

Detail 2.3.1

Conventional Curtain Wall System with Insulated Spandrel Panel– Uninsulated Jamb Intersection with Vision Section

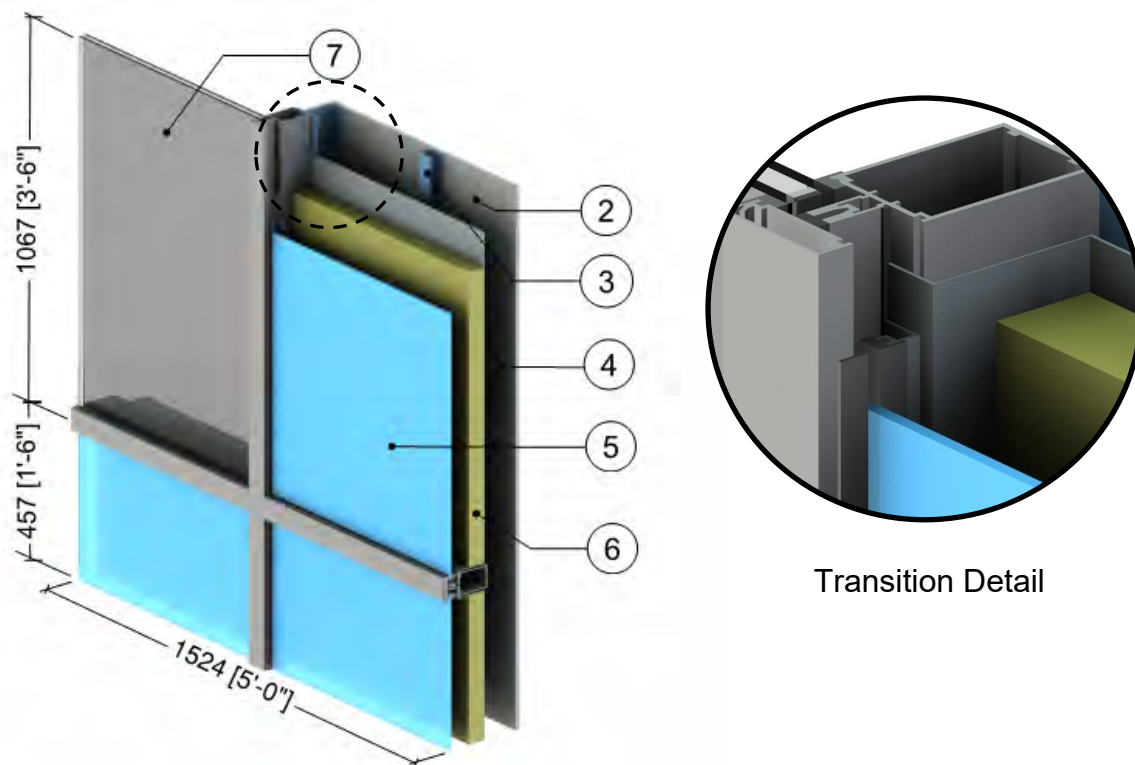

Transition Detail

ID	Component	Thickness Inches (mm)	Conductivity Btu-in / ft ² ·hr·°F (W/m K)	Nominal Resistance hr·ft ² ·°F/Btu (m ² K/W)	Density lb/ft ³ (kg/m ³)	Specific Heat Btu/lb·°F (J/kg K)
1	Interior Film ¹	-	-	R-0.6 to R-1.1 (0.12 to 0.20 RSI)	-	-
2	Gypsum Board	1/2" (13)	1.1 (0.16)	R-0.5 (0.08 RSI)	50 (800)	0.26 (1090)
3	1 5/8" x 1 5/8" Steel Studs (16" o.c.)	18 gauge	430 (62)	-	489 (7830)	0.12 (500)
4	Air in Stud Cavity	3 5/8" (92)	-	R-0.9 (0.16 RSI)	0.075 (1.2)	0.24 (1000)
5	Conventional Curtain Wall Spandrel System with Insulated Backpan: minimal thermally broken frame ²					
6	Backpan Insulation	Varies	0.24 (0.034)	R-8.4 to R-16.8 (1.48 to 2.96 RSI)	4 (64)	0.20 (850)
7	Conventional Curtain Wall Vision System : minimal thermally broken frame ² , double glazed IGU U _{COG} = 0.32 BTU/hr·ft ² ·°F (1.82 W/m ² K)					
8	Exterior Film ¹	-	-	R-0.2 (0.03 RSI)	-	-

¹ Value selected from table 1, p. 26.1 of 2009 ASHRAE Handbook – Fundamentals depending on surface orientation

² The thermal conductivity of air spaces within framing was found using ISO 100077-2

Detail 2.3.2

Conventional Curtain Wall System with Insulated Spandrel Panel– Rigid Insulated Jamb Intersection with Vision Section

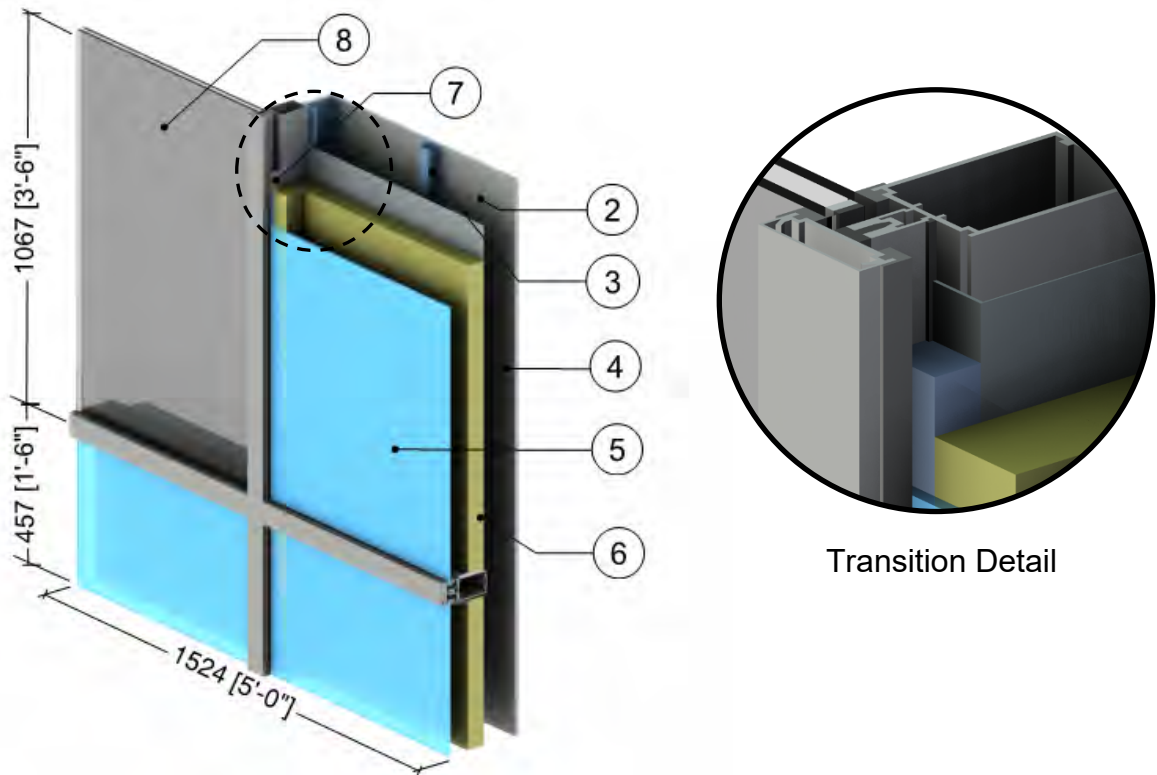

Transition Detail

ID	Component	Thickness Inches (mm)	Conductivity Btu-in / ft ² ·hr·°F (W/m K)	Nominal Resistance hr·ft ² ·°F/Btu (m ² K/W)	Density lb/ft ³ (kg/m ³)	Specific Heat Btu/lb·°F (J/kg K)
1	Interior Film ¹	-	-	R-0.6 to R-1.1 (0.12 to 0.20 RSI)	-	-
2	Gypsum Board	1/2" (13)	1.1 (0.16)	R-0.5 (0.08 RSI)	50 (800)	0.26 (1090)
3	1 5/8" x 1 5/8" Steel Studs (16" o.c.)	18 gauge	430 (62)	-	489 (7830)	0.12 (500)
4	Air in Stud Cavity	3 5/8" (92)	-	R-0.9 (0.16 RSI)	0.075 (1.2)	0.24 (1000)
5	Conventional Curtain Wall Spandrel System with Insulated Backpan: minimal thermally broken frame ²					
6	Backpan Insulation	Varies	0.24 (0.034)	R-8.4 to R-16.8 (1.48 to 2.96 RSI)	4 (64)	0.20 (850)
7	Curtain Wall Insulation	1" (25)	0.24 (0.034)	R-4.0 (0.7 RSI)	4 (64)	0.20 (850)
8	Conventional Curtain Wall Vision System : minimal thermally broken frame ² , double glazed IGU U _{COG} = 0.32 BTU/hr·ft ² ·°F (1.82 W/m ² K)					
9	Exterior Film ¹	-	-	R-0.2 (0.03 RSI)	-	-

¹ Value selected from table 1, p. 26.1 of 2009 ASHRAE Handbook – Fundamentals depending on surface orientation

² The thermal conductivity of air spaces within framing was found using ISO 100077-2

Detail 2.3.3

Conventional Curtain Wall System with Insulated Spandrel Panel – Aerogel Insulated Jamb Intersection with Vision Section

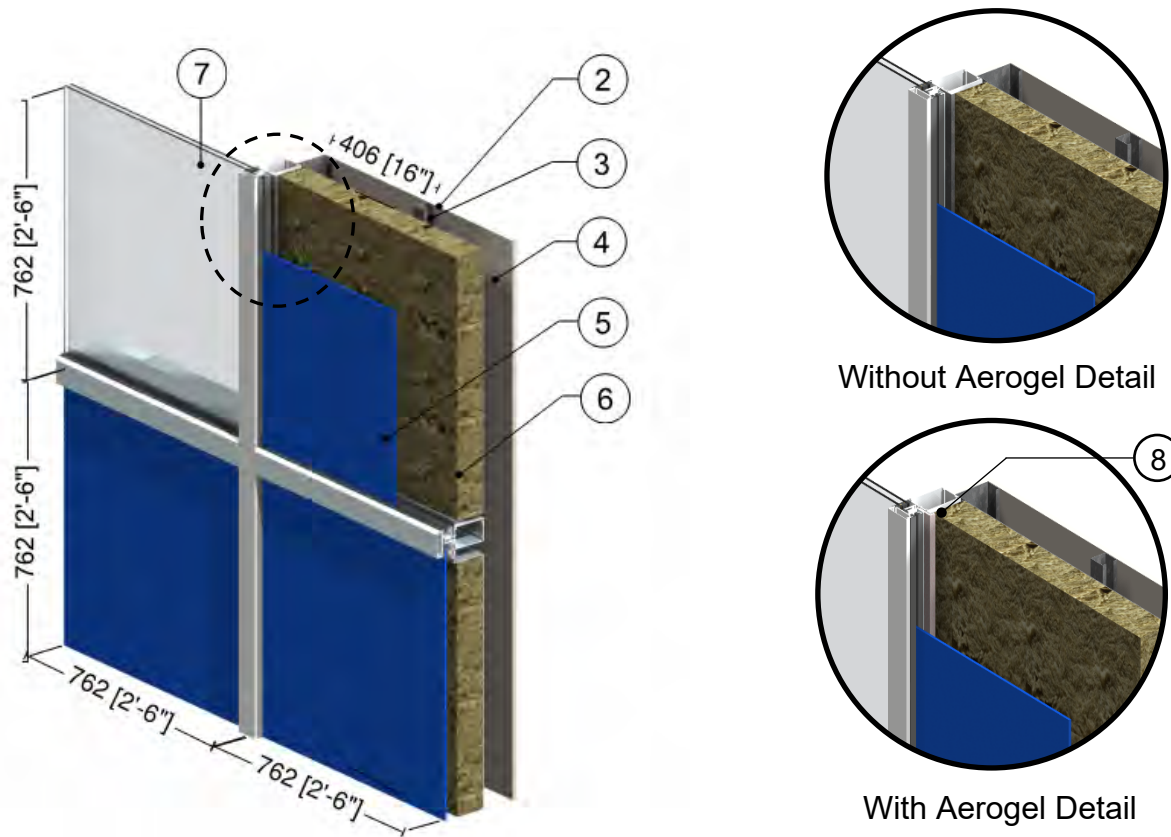

ID	Component	Thickness Inches (mm)	Conductivity Btu-in / ft ² ·hr·°F (W/m K)	Nominal Resistance hr·ft ² ·°F/Btu (m ² K/W)	Density lb/ft ³ (kg/m ³)	Specific Heat Btu/lb·°F (J/kg K)
1	Interior Films ¹	-	-	R-0.6 to R-1.1 (0.12 to 0.20 RSI)	-	-
2	Gypsum Board	1/2" (13)	1.1 (0.16)	R-0.5 (0.08 RSI)	50 (800)	0.26 (1090)
3	1 5/8" x 1 5/8" Steel Studs (16" o.c.)	18 Gauge	430 (62)	-	489 (7830)	0.12 (500)
4	Air in Stud Cavity	3 5/8" (92)	-	R-0.9 (0.16 RSI)	0.075 (1.2)	0.24 (1000)
5	Conventional Curtain Wall Spandrel System with Insulated Backpan: minimal thermally broken frame ²					
6	Backpan Insulation	4" (100)	0.24 (0.034)	R-16.8 (2.96 RSI)	4 (64)	0.20 (850)
7	Conventional Curtain Wall Vision System : minimal thermally broken frame ² , double glazed IGU U _{COG} = 0.32 BTU/hr·ft ² ·°F (1.82 W/m ² K)					
8	Aerogel Blanket	0.4" (10)	0.086 (0.015)	R-3.8 (0.67 RSI)	-	-
9	Exterior Film ¹	-	-	R-0.2 (0.03 RSI)	-	-

¹ Value selected from table 1, p. 26.1 of 2009 ASHRAE Handbook – Fundamentals depending on surface orientation

² The thermal conductivity of air spaces within framing was found using ISO 100077-2

Detail 2.4.1

Conventional Curtain Wall with Insulated Spandrel Panel & 3 5/8" x 1 5/8" Steel Stud (16" o.c.) - Beam Intersection Connected to Concrete Slab

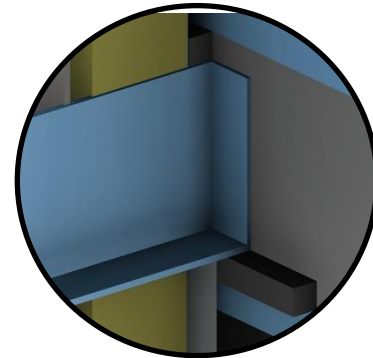
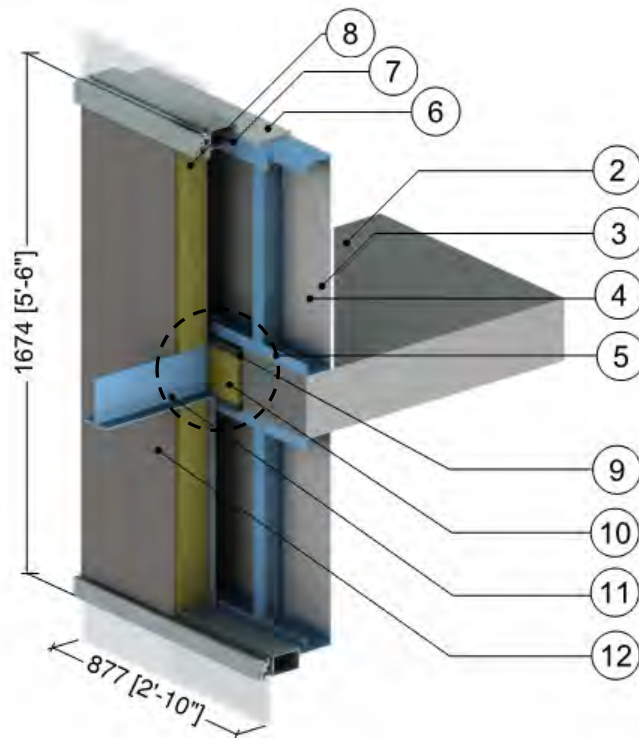

Beam Intersection Detail
(Insulation on slab not shown)

ID	Component	Thickness Inches (mm)	Conductivity Btu-in / ft ² ·hr·°F (W/m K)	Nominal Resistance hr·ft ² ·°F/Btu (m ² K/W)	Density lb/ft ³ (kg/m ³)	Specific Heat Btu/lb·°F (J/kg K)
1	Interior Films ¹	-	-	R-0.6 to R-1.1 (0.12 to 0.20 RSI)	-	-
2	Concrete Slab	8" (203)	12.5 (1.8)	-	140 (2250)	0.20 (850)
3	Gypsum Board	1/2" (13)	1.1 (0.16)	R-0.5 (0.08 RSI)	50 (800)	0.26 (1090)
4	Air Cavity	4 5/8" (117)	-	R-0.9 (0.16 RSI)	0.075 (1.2)	0.24 (1000)
5	3 5/8" x 1 5/8" Steel Studs (16" o.c.) w/ Top & Bottom Tracks	18 Gauge	430 (62)	-	489 (7830)	0.12 (500)
6	Wood Sill	1 1/4" (30)	0.69 (0.10)	-	31 (500)	0.45 (1880)
7	Conventional Curtain wall system: minimal thermally broken frame ² , double glazed IGU U _{COG} = 0.32 BTU/hr·ft ² ·°F (1.82 W/m ² K)					
8	Backpan Insulation	Varies	0.24 (0.034)	R-8.4 to R-16.8 (1.5 RSI to 3.0 RSI)	4 (64)	0.20 (850)
9	Silicone Sealant	1" (25)	2.4 (0.35)	-	174 (2800)	0.17 (700)
10	Semi-Rigid Insulation	1" (25)	0.24 (0.034)	-	4 (64)	0.20 (850)
11	Steel Beam (W6x12)	-	347 (50)	-	489 (7830)	0.12 (500)
12	Composite Metal Panel	3/16" (4)	347 (50)	-	489 (7830)	0.12 (500)
13	Exterior Film ¹	-	-	R-0.2 (0.03 RSI)	-	-

¹ Value selected from table 1, p. 26.1 of 2009 ASHRAE Handbook – Fundamentals depending on surface orientation

² The thermal conductivity of air spaces within framing was found using ISO 100077-2

Detail 2.4.2

Conventional Curtain Wall with Insulated Spandrel Panel & 5 5/8" x 1 5/8" Steel Stud (16" o.c.) - Beam Intersection Connected to Steel Beam

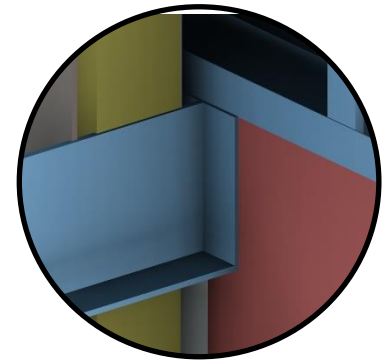
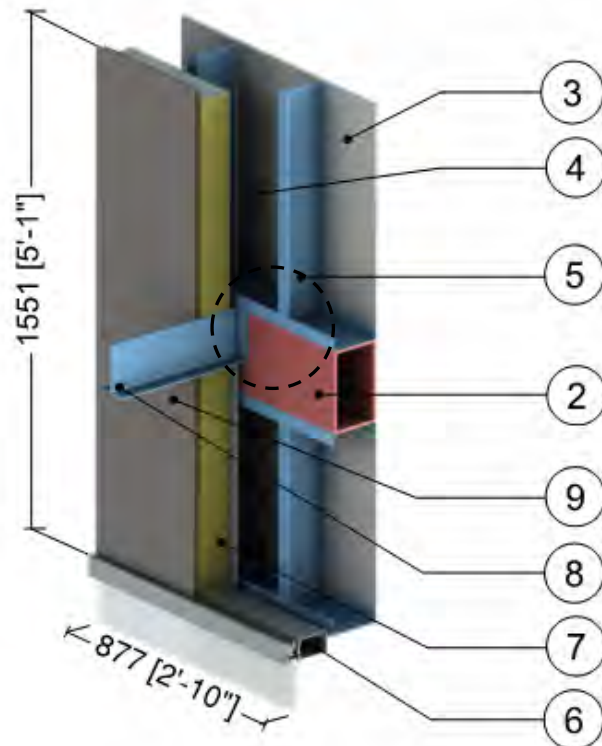

Beam Intersection Detail

ID	Component	Thickness Inches (mm)	Conductivity Btu-in / ft ² ·hr·°F (W/m K)	Nominal Resistance hr·ft ² ·°F/Btu (m ² K/W)	Density lb/ft ³ (kg/m ³)	Specific Heat Btu/lb·°F (J/kg K)
1	Interior Film ¹	-	-	R-0.7 (0.12 RSI)	-	-
2	Structural Steel Beam (10" x 6" x 3/8" HSS)	-	347 (50)	-	489 (7830)	0.12 (500)
3	Gypsum Board	1/2" (13)	1.1 (0.16)	R-0.5 (0.08 RSI)	50 (800)	0.26 (1090)
4	Air Cavity	5 5/8" (168)	-	R-0.9 (0.16 RSI)	0.075 (1.2)	0.24 (1000)
5	5 5/8" x 1 5/8" Steel Studs (16" o.c.) w/ Top & Bottom Tracks	18 Gauge	430 (62)	-	489 (7830)	0.12 (500)
6	Curtain wall system: minimal thermally broken frame ² , double glazed IGU U _{COG} = 0.32 BTU/hr·ft ² ·°F (1.82 W/m ² K)					
7	Backpan Insulation	Varies	0.24 (0.034)	R-8.4 to R-16.8 (1.5 RSI to 3.0 RSI)	4 (64)	0.20 (850)
8	Steel Beam (W6x12)	-	347 (50)	-	489 (7830)	0.12 (500)
9	Composite Metal Panel	3/16" (4)	347 (50)	-	489 (7830)	0.12 (500)
10	Exterior Film ¹	-	-	R-0.2 (0.03 RSI)	-	-

¹ Value selected from table 1, p. 26.1 of 2009 ASHRAE Handbook – Fundamentals depending on surface orientation

² The thermal conductivity of air spaces within framing was found using ISO 100077-2

Detail 2.4.3

Conventional Curtain Wall with Insulated Spandrel Panel & 3 5/8" x 1 5/8" Steel Stud (16" o.c.) - Canopy Beam & Gutter Intersection

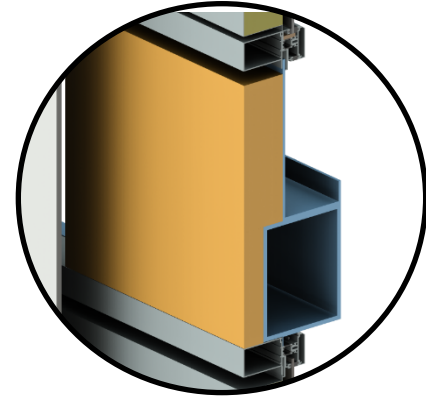
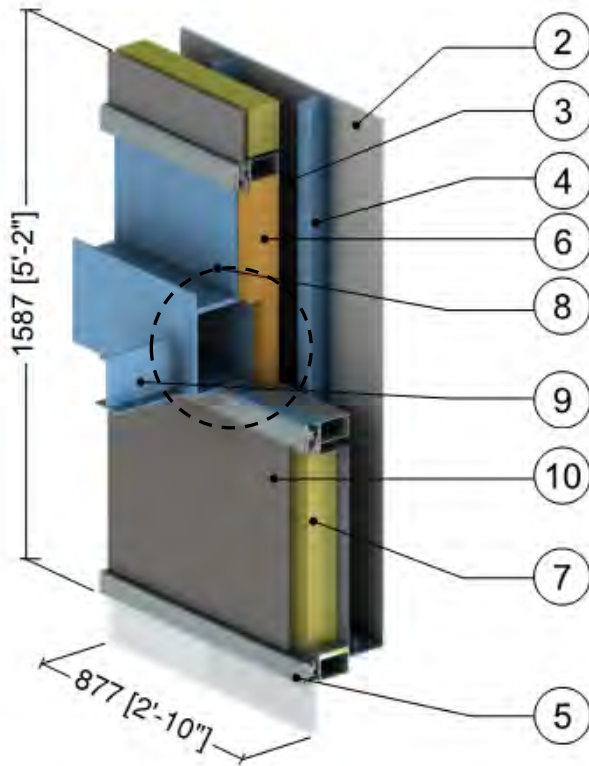

Gutter Intersection Detail

ID	Component	Thickness Inches (mm)	Conductivity Btu-in / ft ² -hr-°F (W/m K)	Nominal Resistance hr-ft ² -°F/Btu (m ² K/W)	Density lb/ft ³ (kg/m ³)	Specific Heat Btu/lb-°F (J/kg K)
1	Interior Film ¹	-	-	R-0.7 (0.12 RSI)	-	-
2	Gypsum Board	1/2" (13)	1.1 (0.16)	R-0.5 (0.08 RSI)	50 (800)	0.26 (1090)
3	Air Cavity	4 5/8" (117)	-	R-0.9 (0.16 RSI)	0.075 (1.2)	0.24 (1000)
4	3 5/8" x 1 5/8" Steel Studs (16" o.c.) w/ Top & Bottom Tracks	18 Gauge	430 (62)	-	489 (7830)	0.12 (500)
5	Curtain wall system: minimal thermally broken frame ² , double glazed IGU U _{COG} = 0.32 BTU/hr-ft ² -°F (1.82 W/m ² K)					
6	Polyurethane Foam Insulation	4" (102)	0.17 (0.024)	R-24 (4.20 RSI)	1.8 (28)	0.29 (1220)
7	Backpan Insulation	Varies	0.24 (0.034)	R-8.4 to R-16.8 (1.5 RSI to 3.0 RSI)	4 (64)	0.20 (850)
8	Steel Beam (HSS 8x10x3/8) & Gutter	-	347 (50)	-	489 (7830)	0.12 (500)
9	Steel Beam (W6x12)	-	347 (50)	-	489 (7830)	0.12 (500)
10	Composite Metal Panel	3/16" (4)	347 (50)	-	489 (7830)	0.12 (500)
11	Exterior Film ¹	-	-	R-0.2 (0.03 RSI)	-	-

¹ Value selected from table 1, p. 26.1 of 2009 ASHRAE Handbook – Fundamentals depending on surface orientation

² The thermal conductivity of air spaces within framing was found using ISO 100077-2

Detail 2.4.4

Conventional Curtain Wall with Insulated Spandrel Panel & 5 5/8" x 1 5/8" Steel Stud (16" o.c.) - Beam Intersection Connected to Steel Beam with Additional Mullions

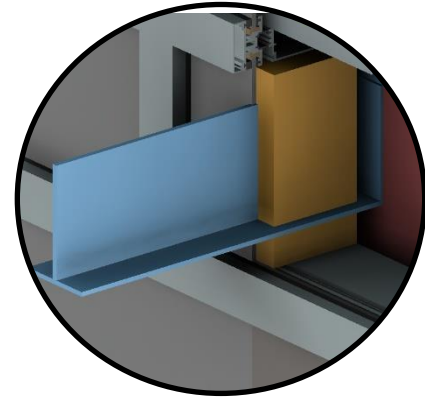
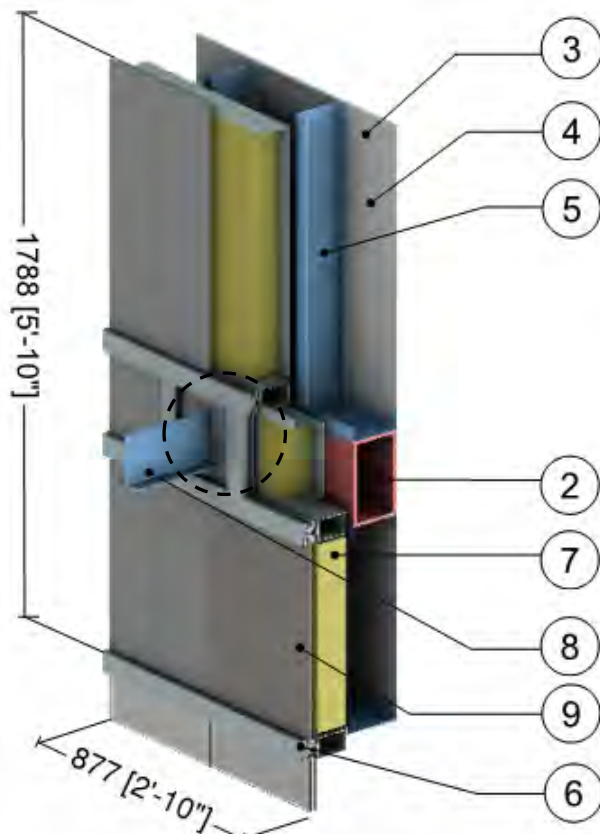

Beam Intersection Detail
(Mullions, cladding and insulation not shown)

ID	Component	Thickness Inches (mm)	Conductivity Btu-in / ft ² ·hr·°F (W/m K)	Nominal Resistance hr·ft ² ·°F/Btu (m ² K/W)	Density lb/ft ³ (kg/m ³)	Specific Heat Btu/lb·°F (J/kg K)
1	Interior Film ¹	-	-	R-0.7 (0.12 RSI)	-	-
2	Structural Steel Beam (10" x 6" x 3/8" HSS)	-	347 (50)	-	489 (7830)	0.12 (500)
3	Gypsum Board	1/2" (13)	1.1 (0.16)	R-0.5 (0.08 RSI)	50 (800)	0.26 (1090)
4	Air Cavity	6 5/8" (117)	-	R-0.9 (0.16 RSI)	0.075 (1.2)	0.24 (1000)
5	5 5/8" x 1 5/8" Steel Studs (16" o.c.) w/ Top & Bottom Tracks	18 Gauge	430 (62)	-	489 (7830)	0.12 (500)
6	Curtain wall system: minimal thermally broken frame ² , double glazed IGU U _{COG} = 0.32 BTU/hr·ft ² ·°F (1.82 W/m ² K)					
7	Backpan Insulation	Varies	0.24 (0.034)	R-8.4 to R-16.8 (1.5 RSI to 3.0 RSI)	4 (64)	0.20 (850)
8	Steel Beam (W6 x12)	-	347 (50)	-	489 (7830)	0.12 (500)
9	Composite Metal Panel	3/16" (4)	347 (50)	-	489 (7830)	0.12 (500)
10	Exterior Film ¹	-	-	R-0.2 (0.03 RSI)	-	-

¹ Value selected from table 1, p. 26.1 of 2009 ASHRAE Handbook – Fundamentals depending on surface orientation

² The thermal conductivity of air spaces within framing was found using ISO 100077-2

Detail 2.5.1

Conventional Curtain Wall System - At-Grade Slab Transition

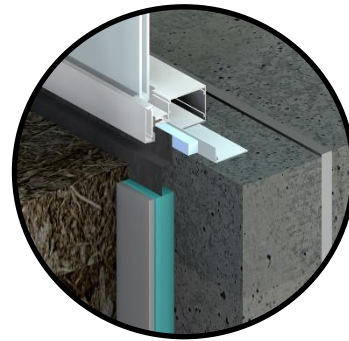
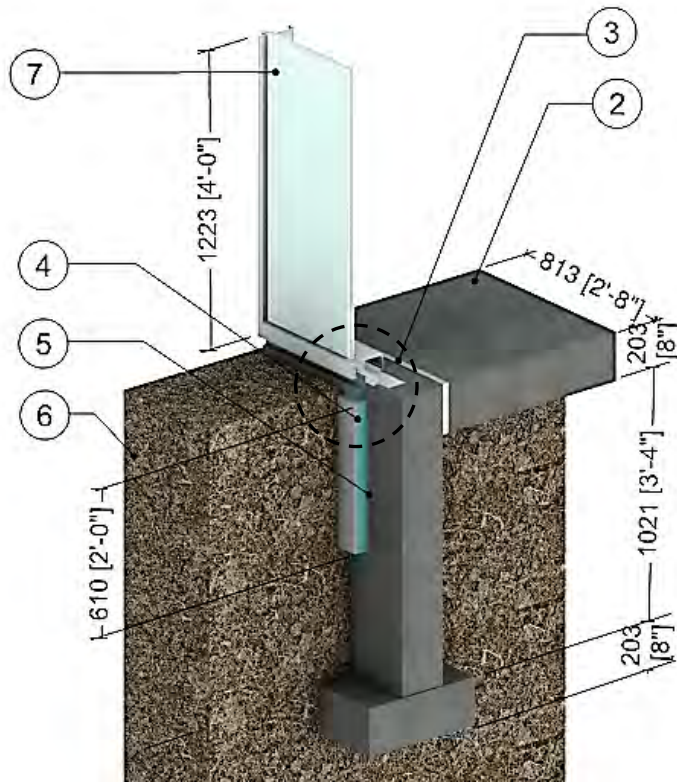

Without Aerogel Detail

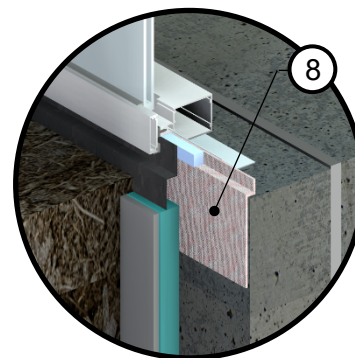

With Aerogel Detail

ID	Component	Thickness Inches (mm)	Conductivity Btu-in / ft ² ·hr·°F (W/m K)	Nominal Resistance hr·ft ² ·°F/Btu (m ² K/W)	Density lb/ft ³ (kg/m ³)	Specific Heat Btu/lb·°F (J/kg K)
1	Interior Films ¹	-	-	R-0.6 to R-0.9 (0.12 to 0.16 RSI)	-	-
2	Concrete Slab on Grade	8" (203)	12.5 (1.8)	-	140 (2250)	0.20 (850)
3	Silicone Sealant	1/2" (13)	2.4 (3.5)	-	-	-
4	Foundation Insulation	2" (50)	-	R-10 (1.8 RSI)	1.8 (28)	0.29 (1220)
5	Concrete Footing	3 5/8" (92)	12.5 (1.8)	R-0.9 (0.16 RSI)	0.075 (1.2)	0.24 (1000)
6	Soil	-	-	-	-	-
7	Conventional Curtain Wall Vision System : minimal thermally broken frame ² , double glazed IGU U _{COG} = 0.32 BTU/hr·ft ² ·°F (1.82 W/m ² K)					
8	Aerogel Blanket	0.4" (10)	0.086 (0.015)	R-3.8 (0.67 RSI)	-	-
9	Exterior Film ¹	-	-	R-0.2 (0.03 RSI)	-	-

¹ Value selected from table 1, p. 26.1 of 2009 ASHRAE Handbook – Fundamentals depending on surface orientation

² The thermal conductivity of air spaces within framing was found using ISO 100077-2

3.0 Unitized Curtain Wall

Detail 3.1.1	A.3.1
Unitized Curtain Wall System – Spandrel Clear Wall & No Interior Stud Cavity Insulation	
Detail 3.1.2	A.3.2
Unitized Curtain Wall System – Spandrel Clear Wall & Interior Spray Foam Insulation	
Detail 3.2.1	A.3.3
Unitized Curtain Wall System – Intermediate Floor Intersection & No Interior Stud Cavity Insulation	
Detail 3.2.2	A.3.4
Unitized Curtain Wall System – Intermediate Floor Intersection & Interior Spray Foam Insulation	
Detail 3.2.3	A.3.5
Unitized Curtain Wall System with 4-Sided Structural Silicone Joints and 5' x 5' Spandrel Section – Insulated Backpan and Intermediate Floor Intersection	
Detail 3.2.4	A.3.6
Unitized Curtain Wall System with 4-Sided Structural Silicone Joints and 5' x 5' Spandrel Section – AIM Applications and Intermediate Floor Intersection	
Detail 3.2.5	A.3.7
Unitized Curtain Wall System with 4-Sided Structural Silicone Joints and 5' x 5' Spandrel Section – Insulated Backpan and Improved Glazing at Intermediate Floor Intersection	
Detail 3.2.6	A.3.8
Unitized Curtain Wall System with 4-Sided Structural Silicone Joints and 5' x 5' Spandrel Section – AIM Applications and Improved Glazing at Intermediate Floor Intersection	
Detail 3.3.1	A.3.9
Unitized Curtain Wall System – Window Wall Transition	
Detail 3.3.2	A.3.10
Unitized Curtain Wall System – Window Wall Transition with Foam Insulation	

Detail 3.1.1

Unitized Curtain Wall System – Spandrel Clear Wall & No Interior Stud Cavity Insulation

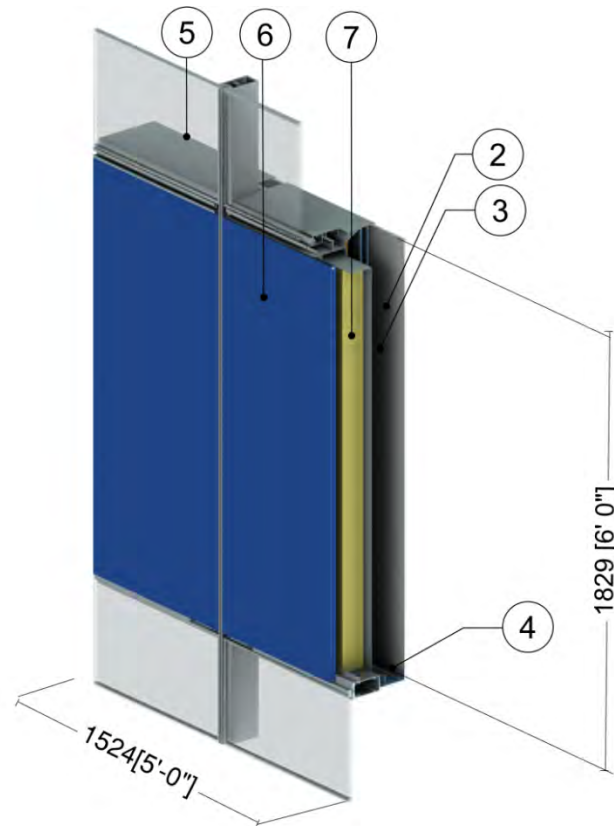

ID	Component	Thickness Inches (mm)	Conductivity Btu-in / ft ² ·hr·°F (W/m K)	Nominal Resistance hr·ft ² ·°F/Btu (m ² K/W)	Density lb/ft ³ (kg/m ³)	Specific Heat Btu/lb·°F (J/kg K)
1	Interior Films ¹	-	-	R-0.6 to R-1.1 (0.12 to 0.20 RSI)	-	-
2	Gypsum Board	1/2" (13)	1.1 (0.16)	R-0.5 (0.08 RSI)	50 (800)	0.26 (1090)
3	Air Cavity	4 5/8" (117)	-	R-0.9 (0.16 RSI)	0.075 (1.2)	0.24 (1000)
4	3 5/8" x 1 5/8" Steel Studs (16"o.c) w/ Top & Bottom Tracks	18 Gauge	430 (62)	-	489 (7830)	0.12 (500)
5	Unitized Curtain Wall Vision System: structural silicone joints ² , double glazed IGU U _{IGU} = 0.32 BTU/hr·ft ² ·°F (1.82 W/m ² K)					
6	Unitized Curtain Wall Spandrel System with Insulated Backpan: structural silicone joints ²					
7	Backpan Insulation	Varies	0.24 (0.034)	R-8.4 to R-16.8 (1.48 to 2.96 RSI)	4 (64)	0.20 (850)
8	Exterior Film ¹	-	-	R-0.2 (0.03 RSI)	-	-

¹ Value selected from table 1, p. 26.1 of 2009 ASHRAE Handbook – Fundamentals depending on surface orientation

² The thermal conductivity of air spaces within framing was found using ISO 100077-2

Detail 3.1.2

Unitized Curtain Wall System – Spandrel Clear Wall & Interior Spray Foam Insulation

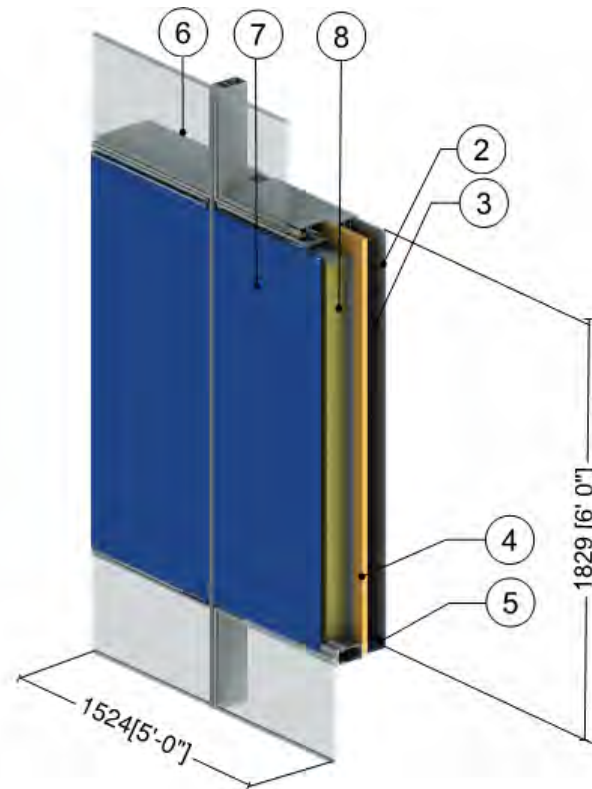

ID	Component	Thickness Inches (mm)	Conductivity Btu-in / ft ² ·hr·°F (W/m K)	Nominal Resistance hr·ft ² ·°F/Btu (m ² K/W)	Density lb/ft ³ (kg/m ³)	Specific Heat Btu/lb·°F (J/kg K)
1	Interior Films ¹	-	-	R-0.6 to R-1.1 (0.12 to 0.20 RSI)	-	-
2	Gypsum Board	1/2" (13)	1.1 (0.16)	R-0.5 (0.08 RSI)	50 (800)	0.26 (1090)
3	Air Cavity	2 5/8" (67)	-	R-0.9 (0.16 RSI)	0.075 (1.2)	0.24 (1000)
4	Spray Foam Insulation	2" (51)	0.17 (0.025)	R-11.5 (2.0 RSI)	2.8 (39)	0.35 (1470)
5	3 5/8" x 1 5/8" Steel Studs (16"o.c) w/ Top & Bottom Tracks	18 Gauge	430 (62)	-	489 (7830)	0.12 (500)
6	Unitized Curtain Wall Vision System: structural silicone joints ² , double glazed IGU U _{IGU} = 0.32 BTU/hr·ft ² ·°F (1.82 W/m ² K)					
7	Unitized Curtain Wall Spandrel System with Insulated Backpan: structural silicone joints ²					
8	Backpan Insulation	Varies	0.24 (0.034)	R-8.4 to R-16.8 (1.48 to 2.96 RSI)	4 (64)	0.20 (850)
9	Exterior Film ¹	-	-	R-0.2 (0.03 RSI)	-	-

¹ Value selected from table 1, p. 26.1 of 2009 ASHRAE Handbook – Fundamentals depending on surface orientation

² The thermal conductivity of air spaces within framing was found using ISO 100077-2

Detail 3.2.1

Unitized Curtain Wall System – Intermediate Floor Intersection & No Interior Stud Cavity Insulation

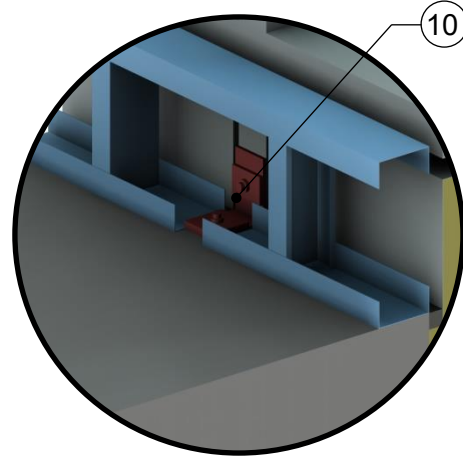
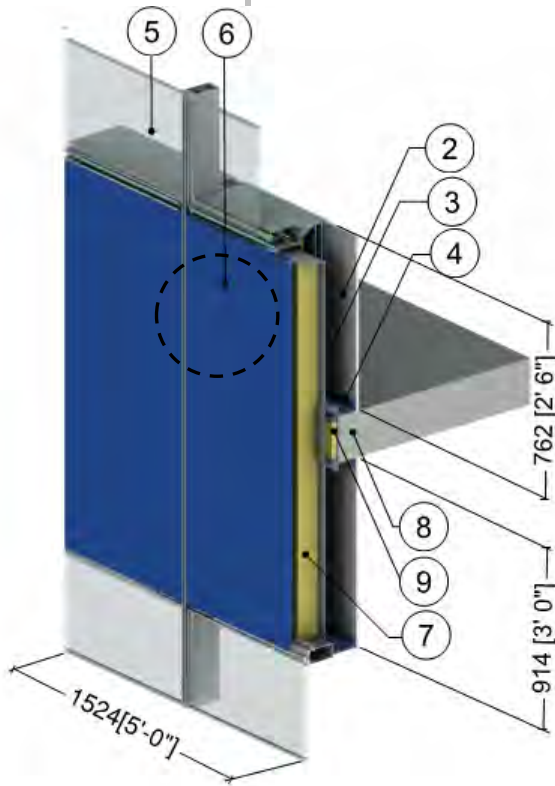

Connection Detail from Interior

ID	Component	Thickness Inches (mm)	Conductivity Btu·in / ft ² ·hr·°F (W/m K)	Nominal Resistance hr·ft ² ·°F/Btu (m ² K/W)	Density lb/ft ³ (kg/m ³)	Specific Heat Btu/lb·°F (J/kg K)
1	Interior Films ¹	-	-	R-0.6 to R-1.1 (0.12 to 0.20 RSI)	-	-
2	Gypsum Board	1/2" (13)	1.1 (0.16)	R-0.5 (0.08 RSI)	50 (800)	0.26 (1090)
3	Air Cavity	2 5/8" (67)	-	R-0.9 (0.16 RSI)	0.075 (1.2)	0.24 (1000)
4	3 5/8" x 1 5/8" Steel Studs (16"o.c) w/ Top & Bottom Tracks	18 Gauge	430 (62)	-	489 (7830)	0.12 (500)
5	Unitized Curtain Wall Vision System: structural silicone joints ² , double glazed IGU U _{IGU} = 0.32 BTU/hr·ft ² ·°F (1.82 W/m ² K)					
6	Unitized Curtain Wall Spandrel System with Insulated Backpan: structural silicone joints ²					
7	Backpan Insulation	Varies	0.24 (0.034)	R-8.4 to R-16.8 (1.48 to 2.96 RSI)	4 (64)	0.20 (850)
8	Concrete Slab	8" (203)	12.5 (1.8)	-	140 (2250)	0.20 (850)
9	Mineral Wool Insulation	1" (25)	0.24 (0.034)	R-4.2 (0.74 RSI)	4 (64)	0.20 (850)
10	Steel Connection Bracket	-	347 (50)	-	489 (7830)	0.12 (500)
11	Exterior Film ¹	-	-	R-0.2 (0.03 RSI)	-	-

¹ Value selected from table 1, p. 26.1 of 2009 ASHRAE Handbook – Fundamentals depending on surface orientation

² The thermal conductivity of air spaces within framing was found using ISO 100077-2

Detail 3.2.2

Unitized Curtain Wall System – Intermediate Floor Intersection & Interior Spray Foam Insulation

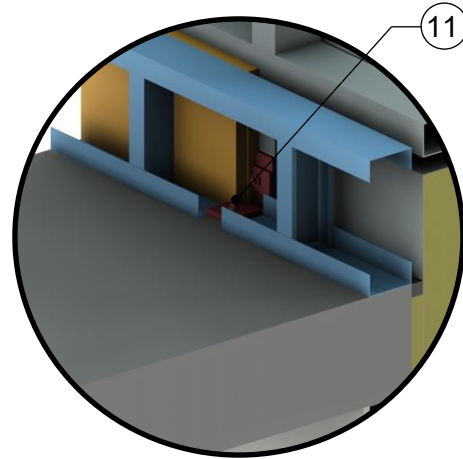
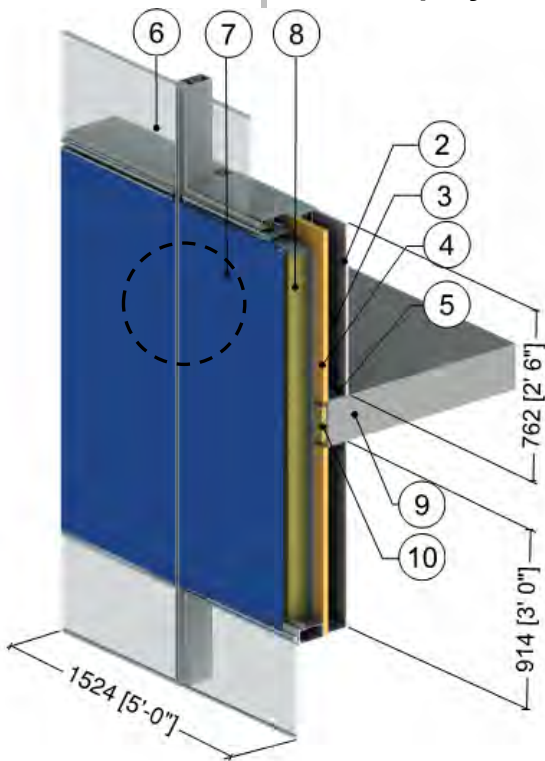

Connection Detail from Interior

ID	Component	Thickness Inches (mm)	Conductivity Btu-in / ft ² ·hr·°F (W/m K)	Nominal Resistance hr·ft ² ·°F/Btu (m ² K/W)	Density lb/ft ³ (kg/m ³)	Specific Heat Btu/lb·°F (J/kg K)
1	Interior Films ¹	-	-	R-0.6 to R-1.1 (0.12 to 0.20 RSI)	-	-
2	Gypsum Board	1/2" (13)	1.1 (0.16)	R-0.5 (0.08 RSI)	50 (800)	0.26 (1090)
3	Air Cavity	2 5/8" (67)	-	R-0.9 (0.16 RSI)	0.075 (1.2)	0.24 (1000)
4	Spray Foam Insulation	2" (51)	0.17 (0.024)	R-12.0 (2.1 RSI)	2.8 (39)	0.35 (1470)
5	3 5/8" x 1 5/8" Steel Studs (16"o.c) w/ Top & Bottom Tracks	18 Gauge	430 (62)	-	489 (7830)	0.12 (500)
6	Unitized Curtain Wall Vision System: structural silicone joints ² , double glazed IGU U _{IGU} = 0.32 BTU/hr·ft ² ·°F (1.82 W/m ² K)					
7	Unitized Curtain Wall Spandrel System with Insulated Backpan: structural silicone joints ²					
8	Backpan Insulation	4" (100)	0.24 (0.034)	R-16.8 (2.96 RSI)	4 (64)	0.20 (850)
9	Concrete Slab	8" (203)	12.5 (1.8)	-	140 (2250)	0.20 (850)
10	Mineral Wool Insulation	1" (25)	0.24 (0.034)	R-4.2 (0.74 RSI)	4 (64)	0.20 (850)
11	Steel Connection Bracket	-	347 (50)	-	489 (7830)	0.12 (500)
12	Exterior Film ¹	-	-	R-0.2 (0.03 RSI)	-	-

¹ Value selected from table 1, p. 26.1 of 2009 ASHRAE Handbook – Fundamentals depending on surface orientation

² The thermal conductivity of air spaces within framing was found using ISO 100077-2

Detail 3.2.3

Unitized Curtain Wall System with 4-Sided Structural Silicone Joints and 5' x 5' Spandrel Section – Insulated Backpan and Intermediate Floor Intersection

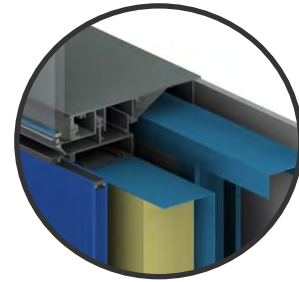
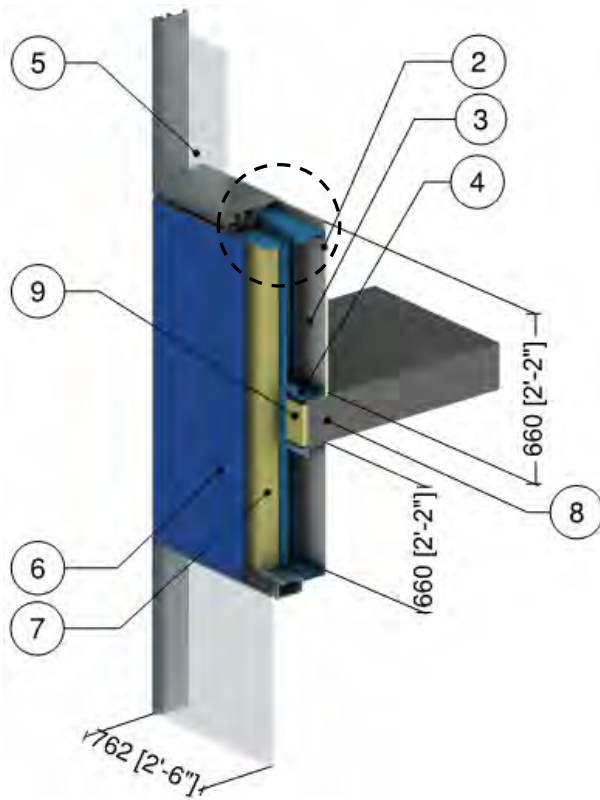

H0.1 – Double Glazed IGU with Aluminum Spacer

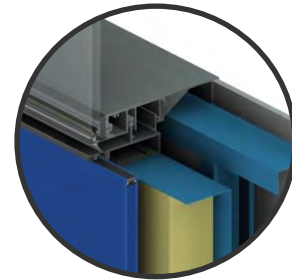

H0.2 – Double Glazed IGU with Silicone Warm Edge Spacer

ID	Component	Thickness Inches (mm)	Conductivity Btu-in / ft ² -hr-°F (W/m K)	Nominal Resistance hr-ft ² -°F/Btu (m ² K/W)	Density lb/ft ³ (kg/m ³)	Specific Heat Btu/lb-°F (J/kg K)
1	Interior Films ¹	-	-	R-0.6 to R-1.1 (0.12 to 0.20 RSI)	-	-
2	Gypsum Board	1/2" (13)	1.1 (0.16)	R-0.5 (0.08 RSI)	50 (800)	0.26 (1090)
3	Air in Stud Cavity	3 5/8" (92)	-	R-0.9 (0.16 RSI)	0.075 (1.2)	0.24 (1000)
4	1 5/8" x 1 5/8" Steel Studs (16"o.c.) with Top and Bottom Tracks	18 Gauge	430 (62)	-	489 (7830)	0.12 (500)
5	Unitized Curtain Wall Vision Section: double glazed IGU with aluminum spacer (H0.1) or warm edge spacer (H0.2) ²					
6	Unitized Curtain Wall Spandrel Section with backpan insulation ^{2,3}					
7	Backpan Insulation	4" (100)	0.24 (0.034)	R-16.8 (2.96 RSI)	4 (64)	0.20 (850)
8	Concrete Slab	8" (203)	12.5 (1.8)	-	140 (2250)	0.20 (850)
9	Mineral Wool Insulation	1" (25)	0.24 (0.034)	R-4.2 (0.74 RSI)	4 (64)	0.20 (850)
10	Exterior Film ¹	-	-	R-0.2 (0.03 RSI)	-	-

¹ Value selected from table 1, p. 26.1 of 2009 ASHRAE Handbook – Fundamentals depending on surface orientation

² The thermal conductivity of air spaces within framing was found using ISO 100077-2

³ For a window to wall ratio of 50%

Detail 3.2.4

Unitized Curtain Wall System with 4-Sided Structural Silicone Joints and 5' x 5' Spandrel Section – AIM Applications and Intermediate Floor Intersection

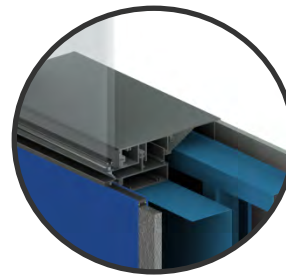
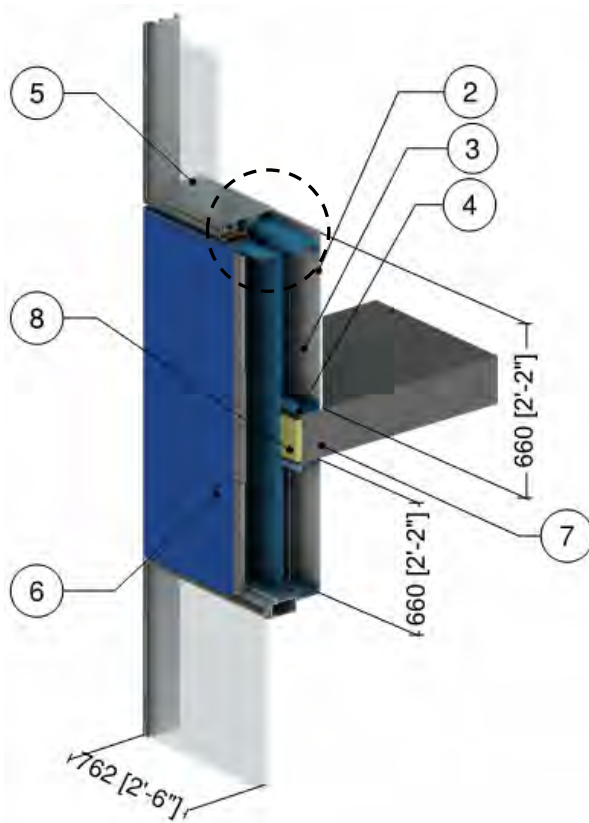

H1 – Warm Edge Spacer, 0.75" (19 mm) AIM between Glass

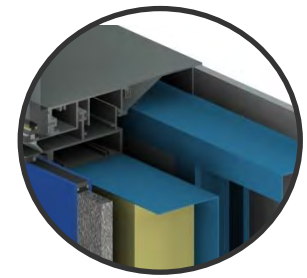

H2 – Warm Edge Spacer, 0.75" (19 mm) AIM between Glass with 4" (100 mm) Backpan Insulation

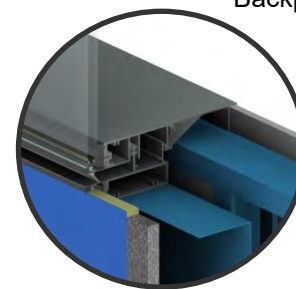

H3 – Rigid Insulation Spacer, 1" (25 mm) AIM between Metal Skins

ID	Component	Thickness Inches (mm)	Conductivity Btu-in / ft ² ·hr·°F (W/m K)	Nominal Resistance hr·ft ² ·°F/Btu (m ² K/W)	Density lb/ft ³ (kg/m ³)	Specific Heat Btu/lb·°F (J/kg K)
1	Interior Films ¹	-	-	R-0.6 to R-1.1 (0.12 to 0.20 RSI)	-	-
2	Gypsum Board	1/2" (13)	1.1 (0.16)	R-0.5 (0.08 RSI)	50 (800)	0.26 (1090)
3	Air in Stud Cavity	3 5/8" (92)	-	R-0.9 (0.16 RSI)	0.075 (1.2)	0.24 (1000)
4	1 5/8" x 1 5/8" Steel Studs (16"o.c.) with Top and Bottom Tracks	18 Gauge	430 (62)	-	489 (7830)	0.12 (500)
5	Unitized Curtain Wall Vision Section: double glazed IGU with silicone warm edge spacer ²					
6	Unitized Curtain Wall Spandrel Section with varied insulation (see H1 to H3 above) ^{2,3}					
7	Concrete Slab	8" (203)	12.5 (1.8)	-	140 (2250)	0.20 (850)
8	Mineral Wool Insulation	1" (25)	0.24 (0.034)	R-4.2 (0.74 RSI)	4 (64)	0.20 (850)
9	Exterior Film ¹	-	-	R-0.2 (0.03 RSI)	-	-

¹ Value selected from table 1, p. 26.1 of 2009 ASHRAE Handbook – Fundamentals depending on surface orientation

² The thermal conductivity of air spaces within framing was found using ISO 100077-2

³ For a window to wall ratio of 50%

AIM = Architectural Insulation Module

Detail 3.2.5

Unitized Curtain Wall System with 4-Sided Structural Silicone Joints and 5' x 5' Spandrel Section – Insulated Backpan and Improved Glazing at Intermediate Floor Intersection

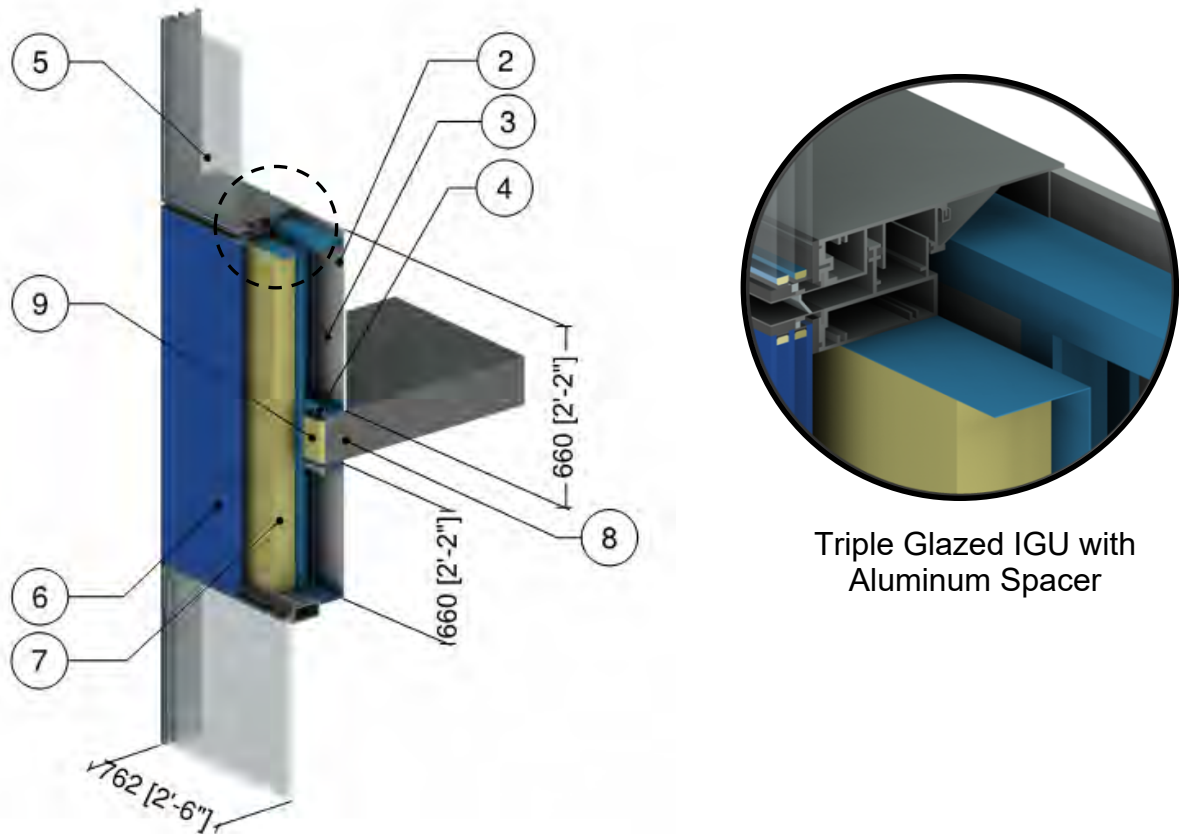

Triple Glazed IGU with Aluminum Spacer

ID	Component	Thickness Inches (mm)	Conductivity Btu-in / ft ² -hr-°F (W/m K)	Nominal Resistance hr-ft ² -°F/Btu (m ² K/W)	Density lb/ft ³ (kg/m ³)	Specific Heat Btu/lb-°F (J/kg K)
1	Interior Films ¹	-	-	R-0.6 to R-1.1 (0.12 to 0.20 RSI)	-	-
2	Gypsum Board	1/2" (13)	1.1 (0.16)	R-0.5 (0.08 RSI)	50 (800)	0.26 (1090)
3	Air in Stud Cavity	3 5/8" (92)	-	R-0.9 (0.16 RSI)	0.075 (1.2)	0.24 (1000)
4	1 5/8" x 1 5/8" Steel Studs (16"o.c.) with Top and Bottom Tracks	18 Gauge	430 (62)	-	489 (7830)	0.12 (500)
5	Unitized Curtain Wall Vision Section: triple glazed IGU with aluminum spacer ²					
6	Unitized Curtain Wall Spandrel Section with Backpan Insulation ^{2,3}					
7	Backpan Insulation	4" (100)	0.24 (0.034)	R-16.8 (2.96 RSI)	4 (64)	0.20 (850)
8	Concrete Slab	8" (203)	12.5 (1.8)	-	140 (2250)	0.20 (850)
9	Mineral Wool Insulation	1" (25)	0.24 (0.034)	R-4.2 (0.74 RSI)	4 (64)	0.20 (850)
10	Exterior Film ¹	-	-	R-0.2 (0.03 RSI)	-	-

¹ Value selected from table 1, p. 26.1 of 2009 ASHRAE Handbook – Fundamentals depending on surface orientation

² The thermal conductivity of air spaces within framing was found using ISO 100077-2

³ For a window to wall ratio of 50%

Detail 3.2.6

Unitized Curtain Wall System with 4-Sided Structural Silicone Joints and 5' x 5' Spandrel Section – AIM Applications and Improved Glazing at Intermediate Floor Intersection

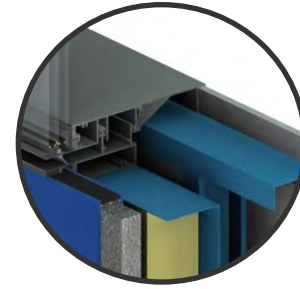
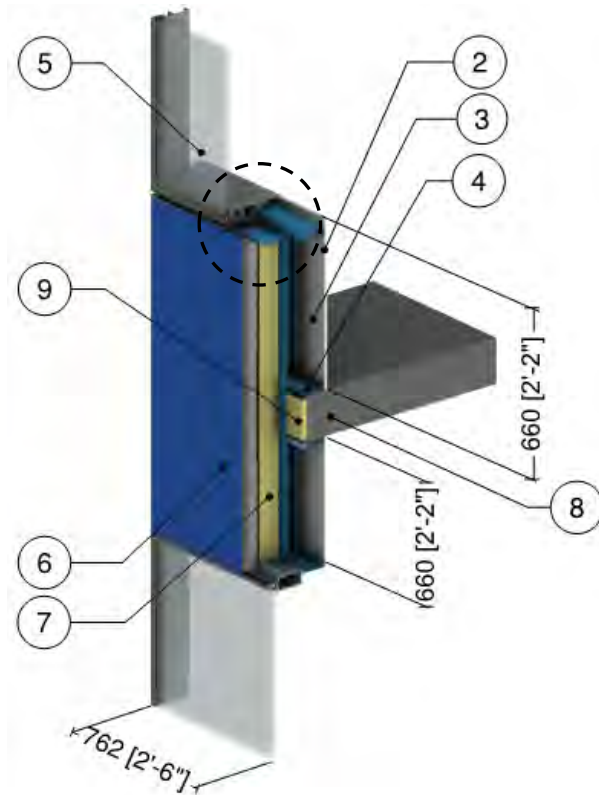

I1 – Warm Edge Spacer, 1.5" (38 mm) AIM between Glass

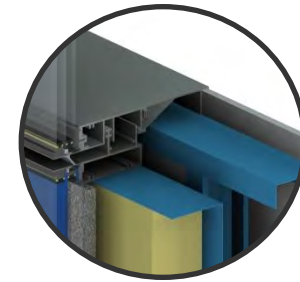

I2 – Warm Edge Spacer, Shadow AIM with 5/8" (16 mm) AIM between Glass

ID	Component	Thickness Inches (mm)	Conductivity Btu-in / ft ² -hr-°F (W/m K)	Nominal Resistance hr-ft ² -°F/Btu (m ² K/W)	Density lb/ft ³ (kg/m ³)	Specific Heat Btu/lb-°F (J/kg K)
1	Interior Films ¹	-	-	R-0.6 to R-1.1 (0.12 to 0.20 RSI)	-	-
2	Gypsum Board	1/2" (13)	1.1 (0.16)	R-0.5 (0.08 RSI)	50 (800)	0.26 (1090)
3	Air in Stud Cavity	3 5/8" (92)	-	R-0.9 (0.16 RSI)	0.075 (1.2)	0.24 (1000)
4	1 5/8" x 1 5/8" Steel Studs (16"o.c.) with Top and Bottom Tracks	18 Gauge	430 (62)	-	489 (7830)	0.12 (500)
5	Unitized Curtain Wall Vision Section: triple glazed IGU with silicone warm edge spacer ²					
6	Unitized Curtain Wall Spandrel Section with varied insulation (see I1 to I2 above) ^{2,3}					
7	Backpan Insulation	4" (100)	0.24 (0.034)	R-16.8 (2.96 RSI)	4 (64)	0.20 (850)
8	Concrete Slab	8" (203)	12.5 (1.8)	-	140 (2250)	0.20 (850)
9	Mineral Wool Insulation	1" (25)	0.24 (0.034)	R-4.2 (0.74 RSI)	4 (64)	0.20 (850)
10	Exterior Film ¹	-	-	R-0.2 (0.03 RSI)	-	-

¹ Value selected from table 1, p. 26.1 of 2009 ASHRAE Handbook – Fundamentals depending on surface orientation

² The thermal conductivity of air spaces within framing was found using ISO 100077-2

³ For a window to wall ratio of 50%

AIM = Architectural Insulation Module

Detail 3.3.1

Unitized Curtain Wall System – Window Wall Transition

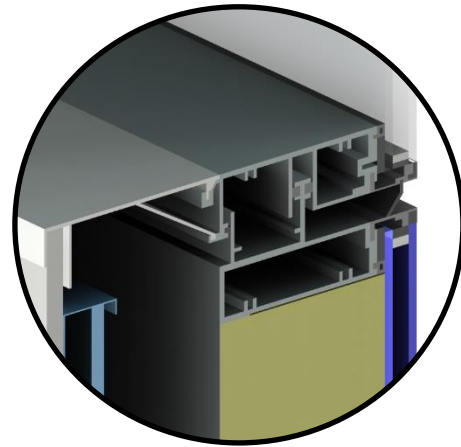
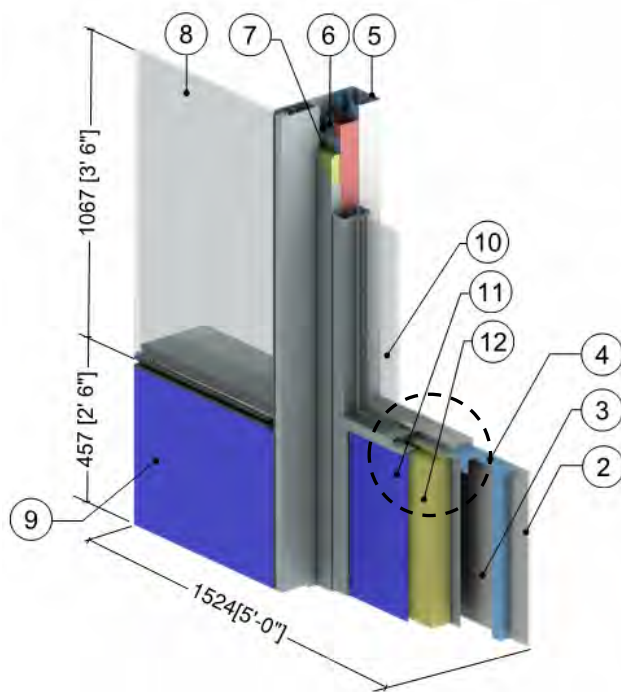

Unitized Curtain Wall Detail

ID	Component	Thickness Inches (mm)	Conductivity Btu·in / ft ² ·hr·°F (W/m K)	Nominal Resistance hr·ft ² ·°F/Btu (m ² K/W)	Density lb/ft ³ (kg/m ³)	Specific Heat Btu/lb·°F (J/kg K)
1	Interior Films ¹	-	-	R-0.6 to R-1.1 (0.12 to 0.20 RSI)	-	-
2	Gypsum Board	1/2" (13)	1.1 (0.16)	R-0.5 (0.08 RSI)	50 (800)	0.26 (1090)
3	Air in Stud Cavity	3 1/8" (79)	-	R-0.9 (0.16 RSI)	0.075 (1.2)	0.24 (1000)
4	1 5/8" x 1 5/8" Steel Studs (16"o.c.) w/ Top & Bottom Tracks	18 Gauge	430 (62)	-	489 (7830)	0.12 (500)
5	3 5/8" x 1 5/8" Steel Studs	18 Gauge	430 (62)	-	489 (7830)	0.12 (500)
6	3" x 3" x 1/8" HSS Column	1/8" (3.2)	430 (62)	-	489 (7830)	0.12 (500)
7	Steel Flashing	18 Gauge	430 (62)	-	489 (7830)	0.12 (500)
8	Unitized Curtain Wall Vision System: structural silicone joints ² , double glazed IGU U _{IGU} = 0.32 BTU/hr·ft ² ·°F (1.82 W/m ² K)					
9	Unitized Curtain Wall Spandrel System with Insulated Backpan: structural silicone joints ²					
10	Aluminum Window Wall Vision System: thermally broken frame ² , double glazed IGU U _{IGU} = 0.32 BTU/hr·ft ² ·°F (1.82 W/m ² K)					
11	Aluminum Window Wall Spandrel System with Insulated Backpan: thermally broken frame ²					
12	Backpan Insulation	Varies	0.24 (0.034)	R-8.4 to R-16.8 (1.48 to 2.96 RSI)	4 (64)	0.20 (850)
13	Exterior Film ¹	-	-	R-0.2 (0.03 RSI)	-	-

¹ Value selected from table 1, p. 26.1 of 2009 ASHRAE Handbook – Fundamentals depending on surface orientation

² The thermal conductivity of air spaces within framing was found using ISO 100077-2

Detail 3.3.2

Unitized Curtain Wall System – Window Wall Transition with Foam Insulation

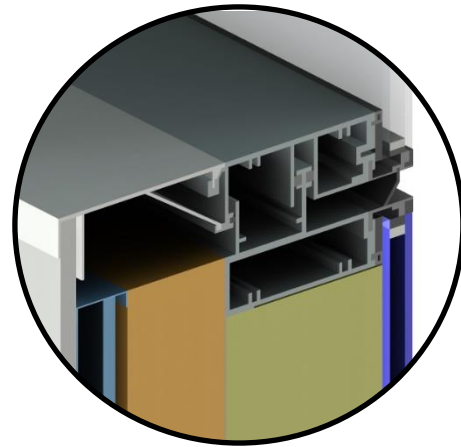
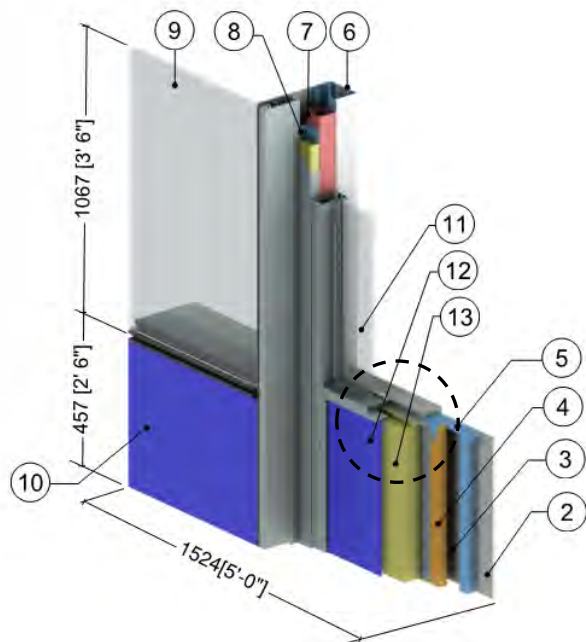

Unitized Curtain Wall Detail

ID	Component	Thickness Inches (mm)	Conductivity Btu-in / ft ² -hr-°F (W/m K)	Nominal Resistance hr-ft ² -°F/Btu (m ² K/W)	Density lb/ft ³ (kg/m ³)	Specific Heat Btu/lb-°F (J/kg K)
1	Interior Films ¹	-	-	R-0.6 to R-1.1 (0.12 to 0.20 RSI)	-	-
2	Gypsum Board	1/2" (13)	1.1 (0.16)	R-0.5 (0.08 RSI)	50 (800)	0.26 (1090)
3	Air in Stud Cavity	1 5/8" (41)	-	R-0.9 (0.16 RSI)	0.075 (1.2)	0.24 (1000)
4	Continuous Spray Foam Insulation	1 1/2" (38)	0.17 (0.024)	R-9.0 (1.58 RSI)	2.8 (39)	0.35 (1470)
5	1 5/8" x 1 5/8" Steel Studs (16"o.c.) w/ Top & Bottom Tracks	18 Gauge	430 (62)	-	489 (7830)	0.12 (500)
6	3 5/8" x 1 5/8" Steel Studs	18 Gauge	430 (62)	-	489 (7830)	0.12 (500)
7	3" x 3" x 1/8" HSS Column	1/8" (3.2)	430 (62)	-	489 (7830)	0.12 (500)
8	Steel Flashing	18 Gauge	430 (62)	-	489 (7830)	0.12 (500)
9	Unitized Curtain Wall Vision System: structural silicone joints ² , double glazed IGU U _{IGU} = 0.32 BTU/hr-ft ² -°F (1.82 W/m ² K)					
10	Unitized Curtain Wall Spandrel System with Insulated Backpan: structural silicone joints ²					
11	Aluminum Window Wall Vision System: thermally broken frame ² , double glazed IGU U _{IGU} = 0.32 BTU/hr-ft ² -°F (1.82 W/m ² K)					
12	Aluminum Window Wall Spandrel System with Insulated Backpan: thermally broken frame ²					
13	Backpan Insulation	Varies	0.24 (0.034)	R-8.4 to R-16.8 (1.48 to 2.96 RSI)	4 (64)	0.20 (850)
14	Exterior Film ¹	-	-	R-0.2 (0.03 RSI)	-	-

¹ Value selected from table 1, p. 26.1 of 2009 ASHRAE Handbook – Fundamentals depending on surface orientation

² The thermal conductivity of air spaces within framing was found using ISO 100077-2

4.0 High Performance Curtain Wall

Detail 4.1.1	A.4.1
High Performance Curtain Wall System – Spandrel Clear Wall & No Interior Stud Cavity Insulation	
Detail 4.1.2	A.4.2
High Performance Curtain Wall System – Spandrel Clear Wall & Interior Spray Foam Insulation	
Detail 4.2.1	A.4.3
High Performance Curtain Wall System – Intermediate Floor Intersection & No Interior Stud Cavity Insulation	
Detail 4.2.2	A.4.4
High Performance Curtain Wall System – Intermediate Floor Intersection & Interior Spray Foam Insulation	
Detail 4.2.3	A.4.5
High Performance Curtain Wall System with Vertical and Horizontal Pressure Plates and 5’ x 5’ Spandrel Section – Insulated Backpan and Intermediate Floor Intersection	
Detail 4.2.4	A.4.6
High Performance Curtain Wall System with Vertical and Horizontal Pressure Plates and 5’ x 5’ Spandrel Section – AIM Applications and Intermediate Floor Intersection	
Detail 4.2.5	A.4.7
High Performance Curtain Wall System with Vertical and Horizontal Pressure Plates, Intermediate Mullion and 5’ x 5’ Spandrel Section – Insulated Backpan and Intermediate Floor Intersection	
Detail 4.2.6	A.4.8
High Performance Curtain Wall System with Vertical and Horizontal Pressure Plates, Intermediate Mullion and 5’ x 5’ Spandrel Section – AIM Applications and Intermediate Floor Intersection	

Detail 4.1.1

High Performance Curtain Wall System – Spandrel Clear Wall & No Interior Stud Cavity Insulation

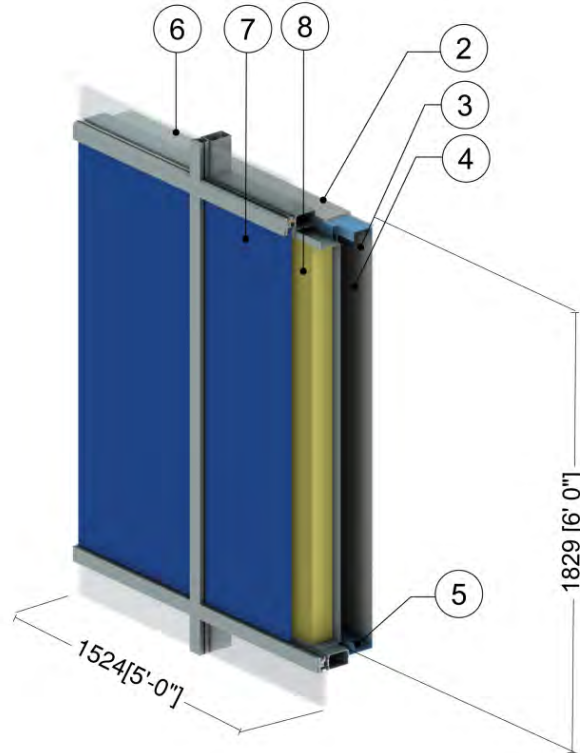

ID	Component	Thickness Inches (mm)	Conductivity Btu-in / ft ² ·hr·°F (W/m K)	Nominal Resistance hr·ft ² ·°F/Btu (m ² K/W)	Density lb/ft ³ (kg/m ³)	Specific Heat Btu/lb·°F (J/kg K)
1	Interior Films ¹	-	-	R-0.6 to R-1.1 (0.12 RSI to 0.20 RSI)	-	-
2	Wood Sill	1 1/4" (30)	0.69 (0.10)	-	27.8 (445)	0.45 (1880)
3	Gypsum Board	1/2" (13)	1.1 (0.16)	R-0.5 (0.08 RSI)	50 (800)	0.26 (1090)
4	Air Cavity	4 5/8" (117)	-	R-0.9 (0.16 RSI)	0.075 (1.2)	0.24 (1000)
5	3 5/8" x 1 5/8" Steel Studs (16"o.c) w/ Top & Bottom Tracks	18 Gauge	430 (62)	-	489 (7830)	0.12 (500)
6	High Perf. Curtain Wall Vision System: thermally broken frame ² , double glazed IGU U _{IGU} = 0.32 BTU/hr-ft ² ·°F (1.82W/m ² K)					
7	High Perf. Curtain Wall Spandrel System with Insulated Backpan: thermally broken frame ²					
8	Backpan Insulation	Varies	0.24 (0.034)	R-8.4 to R-16.8 (1.48 to 2.96 RSI)	4 (64)	0.20 (850)
9	Exterior Film ¹	-	-	R-0.2 (0.03 RSI)	-	-

¹ Value selected from table 1, p. 26.1 of 2009 ASHRAE Handbook – Fundamentals depending on surface orientation

² The thermal conductivity of air spaces within framing was found using ISO 100077-2

Detail 4.1.2

High Performance Curtain Wall System – Spandrel Clear Wall & Interior Spray Foam Insulation

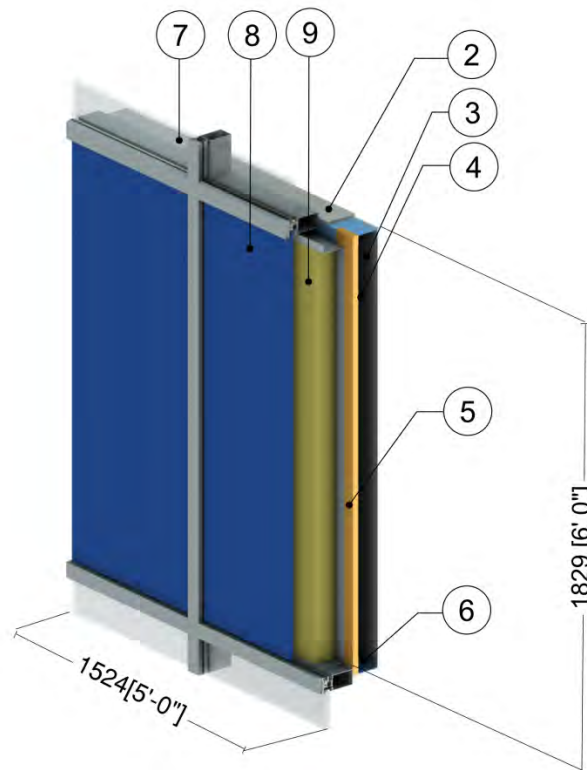

ID	Component	Thickness Inches (mm)	Conductivity Btu-in / ft ² ·hr·°F (W/m K)	Nominal Resistance hr·ft ² ·°F/Btu (m ² K/W)	Density lb/ft ³ (kg/m ³)	Specific Heat Btu/lb·°F (J/kg K)
1	Interior Films ¹	-	-	R-0.6 to R-1.1 (0.12 RSI to 0.20 RSI)	-	-
2	Wood Sill	1 1/4" (30)	0.69 (0.10)	-	27.8 (445)	0.45 (1880)
3	Gypsum Board	1/2" (13)	1.1 (0.16)	R-0.5 (0.08 RSI)	50 (800)	0.26 (1090)
4	Air Cavity	4 5/8" (117)	-	R-0.9 (0.16 RSI)	0.075 (1.2)	0.24 (1000)
5	Spray Foam Insulation	2" (51)	0.17 (0.025)	R-11.5 (2.0 RSI)	2.8 (39)	0.35 (1470)
6	3 5/8" x 1 5/8" Steel Studs (16"o.c.) w/ Top & Bottom Tracks	18 Gauge	430 (62)	-	489 (7830)	0.12 (500)
7	High Perf. Curtain Wall Vision System: thermally broken frame ² , double glazed IGU U _{IGU} = 0.32 BTU/hr·ft ² ·°F (1.82W/m ² K)					
8	High Perf. Curtain Wall Spandrel System with Insulated Backpan: thermally broken frame ²					
9	Backpan Insulation	Varies	0.24 (0.034)	R-8.4 to R-16.8 (1.48 to 2.96 RSI)	4 (64)	0.20 (850)
10	Exterior Film ¹	-	-	R-0.2 (0.03 RSI)	-	-

¹ Value selected from table 1, p. 26.1 of 2009 ASHRAE Handbook – Fundamentals depending on surface orientation

² The thermal conductivity of air spaces within framing was found using ISO 100077-2

Detail 4.2.1

High Performance Curtain Wall System – Intermediate Floor Intersection & No Interior Stud Cavity Insulation

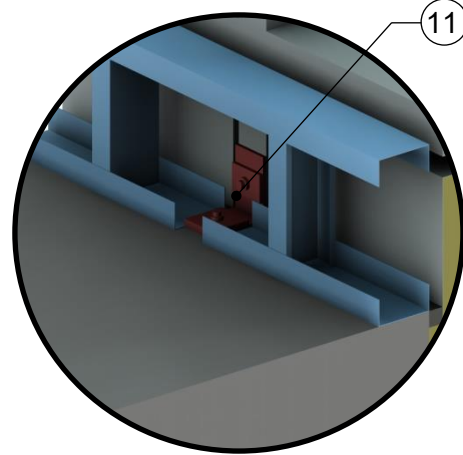
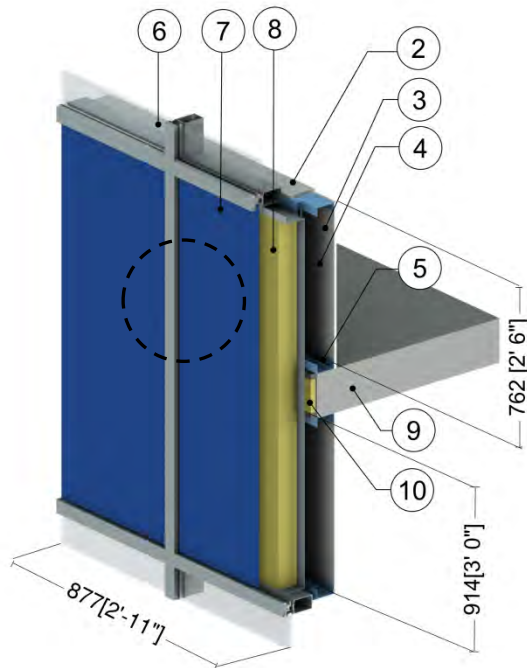

Connection Detail from Interior

ID	Component	Thickness Inches (mm)	Conductivity Btu·in / ft ² ·hr·°F (W/m K)	Nominal Resistance hr·ft ² ·°F/Btu (m ² K/W)	Density lb/ft ³ (kg/m ³)	Specific Heat Btu/lb·°F (J/kg K)
1	Interior Films ¹	-	-	R-0.6 to R-1.1 (0.12 RSI to 0.20 RSI)	-	-
2	Wood Sill	1 1/4" (30)	0.69 (0.10)	-	27.8 (445)	0.45 (1880)
3	Gypsum Board	1/2" (13)	1.1 (0.16)	R-0.5 (0.08 RSI)	50 (800)	0.26 (1090)
4	Air Cavity	2 5/8" (67)	-	R-0.9 (0.16 RSI)	0.075 (1.2)	0.24 (1000)
5	3 5/8" x 1 5/8" Steel Studs (16"o.c.) w/ Top & Bottom Tracks	18 Gauge	430 (62)	-	489 (7830)	0.12 (500)
6	High Perf. Curtain Wall Vision System: thermally broken frame ² , double glazed IGU U _{IGU} = 0.32 BTU/hr·ft ² ·°F (1.82W/m ² K)					
7	High Perf. Curtain Wall Spandrel System with Insulated Backpan: thermally broken frame ²					
8	Backpan Insulation	Varies	0.24 (0.034)	R-8.4 to R-16.8 (1.48 to 2.96 RSI)	4 (64)	0.20 (850)
9	Concrete Slab	8" (203)	12.5 (1.8)	-	140 (2250)	0.20 (850)
10	Mineral Wool Insulation	1" (25)	0.24 (0.034)	R-4.2 (0.74 RSI)	4 (64)	0.20 (850)
11	Steel Connection Bracket	-	347 (50)	-	489 (7830)	0.12 (500)
12	Exterior Film ¹	-	-	R-0.2 (0.03 RSI)	-	-

¹ Value selected from table 1, p. 26.1 of 2009 ASHRAE Handbook – Fundamentals depending on surface orientation

² The thermal conductivity of air spaces within framing was found using ISO 100077-2

Detail 4.2.2

High Performance Curtain Wall System – Intermediate Floor Intersection & Interior Spray Foam Insulation

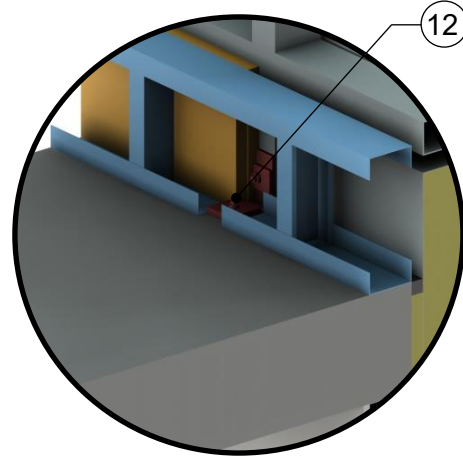
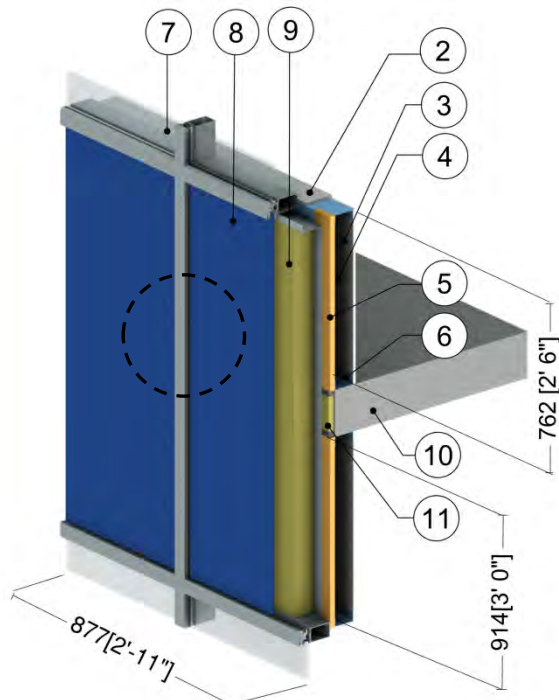

Connection Detail from Interior

ID	Component	Thickness Inches (mm)	Conductivity Btu-in / ft ² ·hr·°F (W/m K)	Nominal Resistance hr·ft ² ·°F/Btu (m ² K/W)	Density lb/ft ³ (kg/m ³)	Specific Heat Btu/lb·°F (J/kg K)
1	Interior Films ¹	-	-	R-0.6 to R-1.1 (0.12 RSI to 0.20 RSI)	-	-
2	Wood Sill	1 1/2" (30)	0.69 (0.10)	-	27.8 (445)	0.45 (1880)
3	Gypsum Board	1/2" (13)	1.1 (0.16)	R-0.5 (0.08 RSI)	50 (800)	0.26 (1090)
4	Air Cavity	2 5/8" (67)	-	R-0.9 (0.16 RSI)	0.075 (1.2)	0.24 (1000)
5	Spray Foam Insulation	2" (51)	0.17 (0.025)	R-11.5 (2.0 RSI)	2.8 (39)	0.35 (1470)
6	3 5/8" x 1 5/8" Steel Studs (16"o.c.) w/ Top & Bottom Tracks	18 Gauge	430 (62)	-	489 (7830)	0.12 (500)
7	High Perf. Curtain Wall Vision System: thermally broken frame ² , double glazed IGU U _{IGU} = 0.32 BTU/hr-ft ² ·°F (1.82W/m ² K)					
8	High Perf. Curtain Wall Spandrel System with Insulated Backpan: thermally broken frame ²					
9	Backpan Insulation	Varies	0.24 (0.034)	R-8.4 to R-16.8 (1.48 to 2.96 RSI)	4 (64)	0.20 (850)
10	Concrete Slab	8" (203)	12.5 (1.8)	-	140 (2250)	0.20 (850)
11	Mineral Wool Insulation	1" (25)	0.24 (0.034)	R-4.2 (0.74 RSI)	4 (64)	0.20 (850)
12	Steel Connection Bracket	-	347 (50)	-	489 (7830)	0.12 (500)
13	Exterior Film ¹	-	-	R-0.2 (0.03 RSI)	-	-

¹ Value selected from table 1, p. 26.1 of 2009 ASHRAE Handbook – Fundamentals depending on surface orientation

² The thermal conductivity of air spaces within framing was found using ISO 100077-2

Detail 4.2.3

High Performance Curtain Wall System with Vertical and Horizontal Pressure Plates and 5' x 5' Spandrel Section – Insulated Backpan and Intermediate Floor Intersection

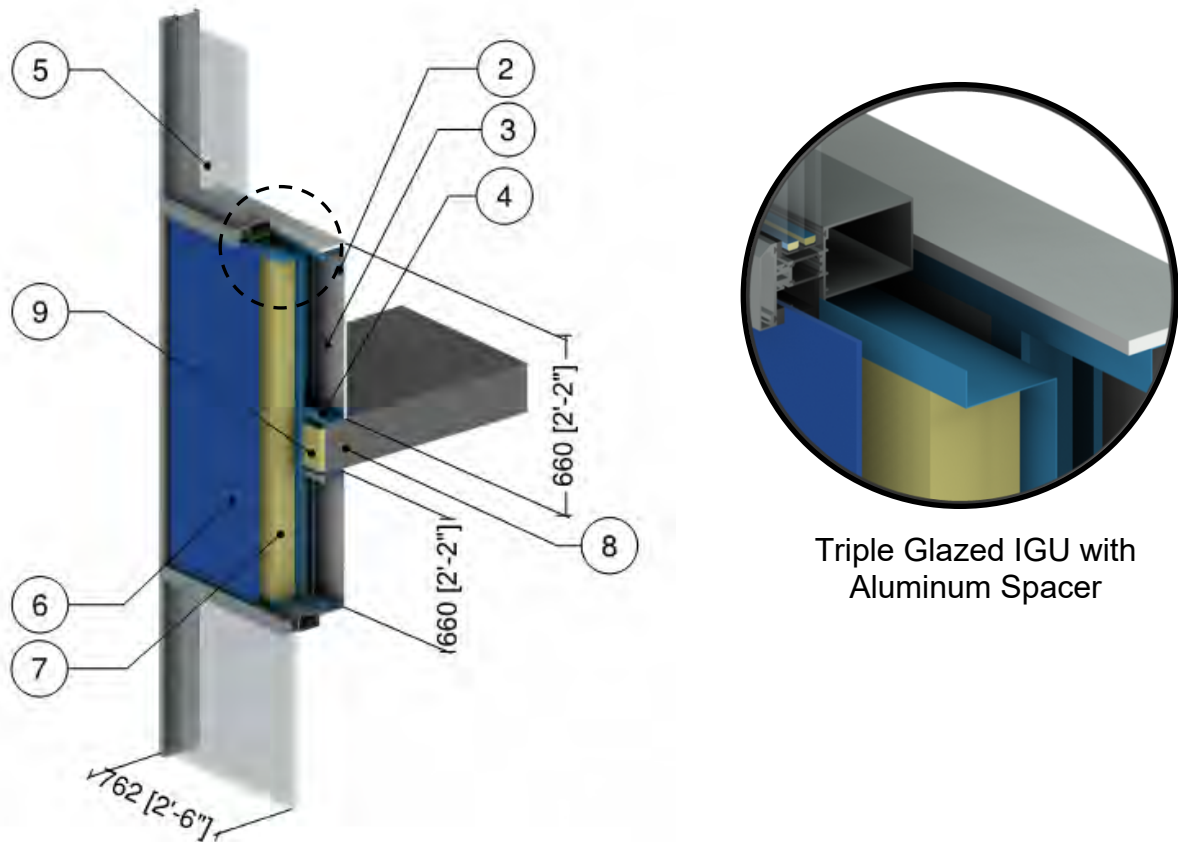

Triple Glazed IGU with Aluminum Spacer

ID	Component	Thickness Inches (mm)	Conductivity Btu-in / ft ² ·hr·°F (W/m K)	Nominal Resistance hr·ft ² ·°F/Btu (m ² K/W)	Density lb/ft ³ (kg/m ³)	Specific Heat Btu/lb·°F (J/kg K)
1	Interior Films ¹	-	-	R-0.6 to R-1.1 (0.12 RSI to 0.20 RSI)	-	-
2	Gypsum Board	1/2" (13)	1.1 (0.16)	R-0.5 (0.08 RSI)	50 (800)	0.26 (1090)
3	Air in Stud Cavity	3 5/8" (92)	-	R-0.9 (0.16 RSI)	0.075 (1.2)	0.24 (1000)
4	1 5/8" x 1 5/8" Steel Studs (16"o.c.) with Top and Bottom Tracks	18 Gauge	430 (62)	-	489 (7830)	0.12 (500)
5	High Performance Curtain Wall Vision Section: triple glazed IGU with aluminum spacer ²					
6	High Performance Curtain Wall Spandrel Section with Backpan Insulation ^{2,3}					
7	Backpan Insulation	4" (100)	0.24 (0.034)	R-16.8 (2.96 RSI)	4 (64)	0.20 (850)
8	Concrete Slab	8" (203)	12.5 (1.8)	-	140 (2250)	0.20 (850)
9	Mineral Wool Insulation	1" (25)	0.24 (0.034)	R-4.2 (0.74 RSI)	4 (64)	0.20 (850)
10	Exterior Film ¹	-	-	R-0.2 (0.03 RSI)	-	-

¹ Value selected from table 1, p. 26.1 of 2009 ASHRAE Handbook – Fundamentals depending on surface orientation

² The thermal conductivity of air spaces within framing was found using ISO 100077-2

³ For a window to wall ratio of 50%

Detail 4.2.4

High Performance Curtain Wall System with Vertical and Horizontal Pressure Plates and 5' x 5' Spandrel Section – AIM Applications and Intermediate Floor Intersection

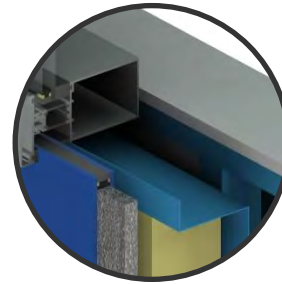
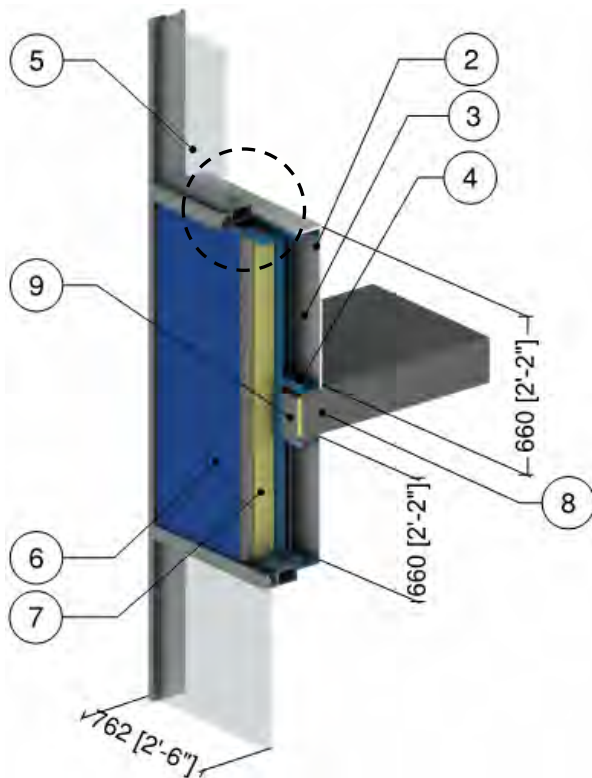

E1 – Warm Edge Spacer, 0.75" (19 mm) AIM between Glass

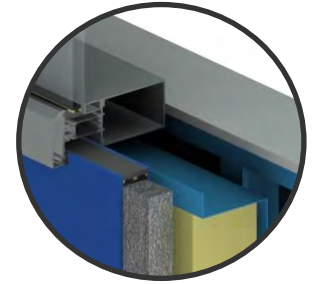

E2 – Warm Edge Spacer, 1.5" (38 mm) AIM between Glass

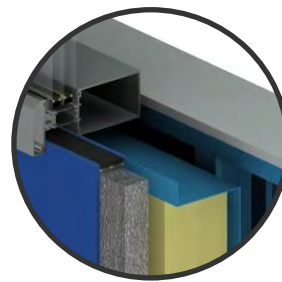

E3 – Warm Edge Spacer, 1.5" (38 mm) AIM between Glass

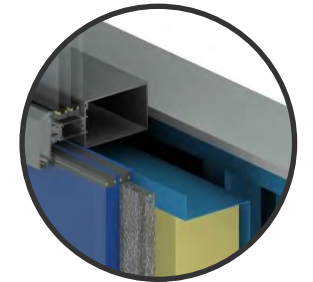

E4 – Warm Edge Spacer, Shadow AIM with 5/8" (16 mm) AIM in Secondary Unit

ID	Component	Thickness Inches (mm)	Conductivity Btu-in / ft ² -hr-°F (W/m K)	Nominal Resistance hr-ft ² -°F/Btu (m ² K/W)	Density lb/ft ³ (kg/m ³)	Specific Heat Btu/lb-°F (J/kg K)
1	Interior Films ¹	-	-	R-0.6 to R-1.1 (0.12 RSI to 0.20 RSI)	-	-
2	Gypsum Board	1/2" (13)	1.1 (0.16)	R-0.5 (0.08 RSI)	50 (800)	0.26 (1090)
3	Air in Stud Cavity	3 5/8" (92)	-	R-0.9 (0.16 RSI)	0.075 (1.2)	0.24 (1000)
4	1 5/8" x 1 5/8" Steel Studs (16"o.c.) with Top and Bottom Tracks	18 Gauge	430 (62)	-	489 (7830)	0.12 (500)
5	High Performance Curtain Wall Vision Section: double glazed (E1 & E2) or triple glazed (E3 & E4) IGU with warm edge spacer ²					
6	High Performance Curtain Wall Spandrel Section with varied insulation (see E1 to E4 above) ^{2,3}					
7	Backpan Insulation	4" (100)	0.24 (0.034)	R-16.8 (2.96 RSI)	4 (64)	0.20 (850)
8	Concrete Slab	8" (203)	12.5 (1.8)	-	140 (2250)	0.20 (850)
9	Mineral Wool Insulation	1" (25)	0.24 (0.034)	R-4.2 (0.74 RSI)	4 (64)	0.20 (850)
10	Exterior Film ¹	-	-	R-0.2 (0.03 RSI)	-	-

¹ Value selected from table 1, p. 26.1 of 2009 ASHRAE Handbook – Fundamentals depending on surface orientation

² The thermal conductivity of air spaces within framing was found using ISO 100077-2

³ For a window to wall ratio of 50%

AIM = Architectural Insulation Module

Detail 4.2.5

High Performance Curtain Wall System with Vertical and Horizontal Pressure Plates, Intermediate Mullion and 5' x 5' Spandrel Section – Insulated Backpan and Intermediate Floor Intersection

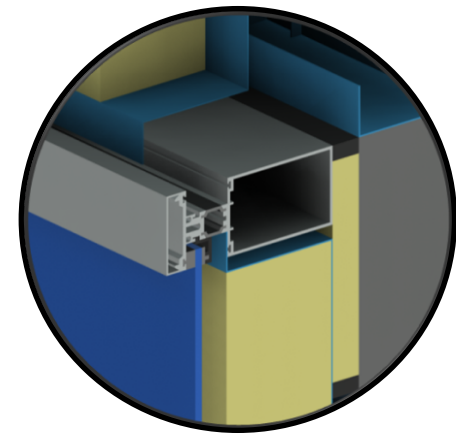
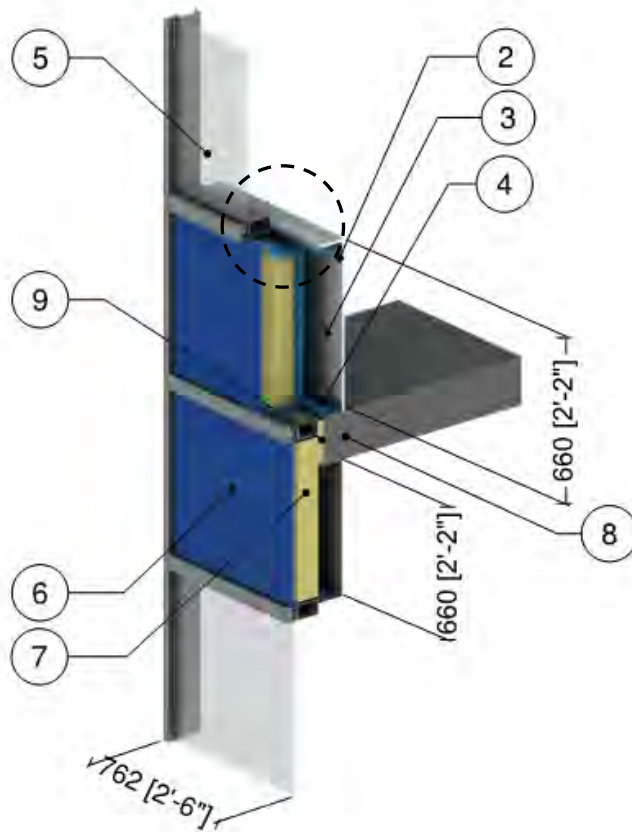

Double Glazed IGU with Silicone Warm Edge Spacer

ID	Component	Thickness Inches (mm)	Conductivity Btu-in / ft ² ·hr·°F (W/m K)	Nominal Resistance hr·ft ² ·°F/Btu (m ² K/W)	Density lb/ft ³ (kg/m ³)	Specific Heat Btu/lb·°F (J/kg K)
1	Interior Films ¹	-	-	R-0.6 to R-1.1 (0.12 RSI to 0.20 RSI)	-	-
2	Gypsum Board	1/2" (13)	1.1 (0.16)	R-0.5 (0.08 RSI)	50 (800)	0.26 (1090)
3	Air in Stud Cavity	3 5/8" (92)	-	R-0.9 (0.16 RSI)	0.075 (1.2)	0.24 (1000)
4	1 5/8" x 1 5/8" Steel Studs (16"o.c.) with Top and Bottom Tracks	18 Gauge	430 (62)	-	489 (7830)	0.12 (500)
5	High Performance Curtain Wall Vision Section: double glazed IGU with silicone warm edge spacer ²					
6	High Performance Curtain Wall Spandrel Section with Backpan Insulation ^{2,3}					
7	Backpan Insulation	4" (100)	0.24 (0.034)	R-16.8 (2.96 RSI)	4 (64)	0.20 (850)
8	Concrete Slab	8" (203)	12.5 (1.8)	-	140 (2250)	0.20 (850)
9	Mineral Wool Insulation	1" (25)	0.24 (0.034)	R-4.2 (0.74 RSI)	4 (64)	0.20 (850)
10	Exterior Film ¹	-	-	R-0.2 (0.03 RSI)	-	-

¹ Value selected from table 1, p. 26.1 of 2009 ASHRAE Handbook – Fundamentals depending on surface orientation

² The thermal conductivity of air spaces within framing was found using ISO 100077-2

³ For a window to wall ratio of 50%

Detail 4.2.6

High Performance Curtain Wall System with Vertical and Horizontal Pressure Plates, Intermediate Mullion and 5' x 5' Spandrel Section – AIM Applications and Intermediate Floor Intersection

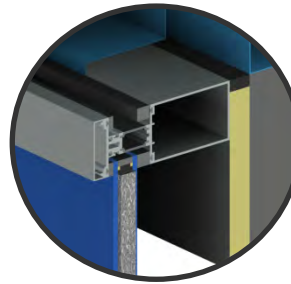
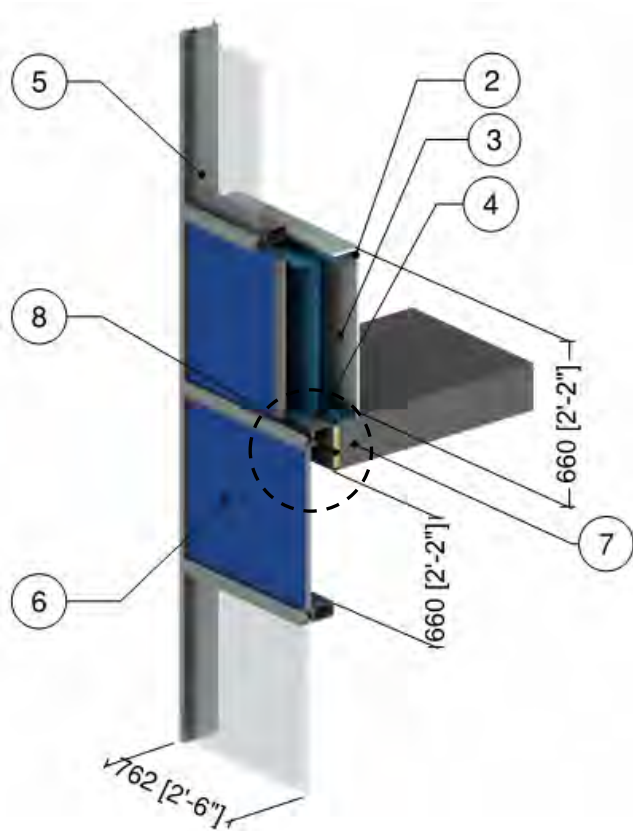

F1 – Warm Edge Spacer, 0.75" (19 mm) AIM between Glass

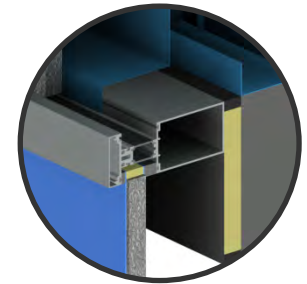

F2 – Rigid Insulation Spacer, 1" (25 mm) AIM between Metal Skins

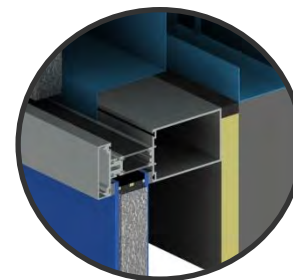

F3 – Warm Edge Spacer, 1.5" (38 mm) AIM between Glass

ID	Component	Thickness Inches (mm)	Conductivity Btu-in / ft ² ·hr·°F (W/m K)	Nominal Resistance hr·ft ² ·°F/Btu (m ² K/W)	Density lb/ft ³ (kg/m ³)	Specific Heat Btu/lb·°F (J/kg K)
1	Interior Films ¹	-	-	R-0.6 (0.12 RSI) to R-1.1 (0.20 RSI)	-	-
2	Gypsum Board	1/2" (13)	1.1 (0.16)	R-0.5 (0.08 RSI)	50 (800)	0.26 (1090)
3	Air in Stud Cavity	3 5/8" (92)	-	R-0.9 (0.16 RSI)	0.075 (1.2)	0.24 (1000)
4	1 5/8" x 1 5/8" Steel Studs (16"o.c.) with Top and Bottom Tracks	18 Gauge	430 (62)	-	489 (7830)	0.12 (500)
5	High Performance Curtain Wall Vision Section: double glazed (F1 & F2) or triple glazed (F3) IGU with warm edge spacer ²					
6	High Performance Curtain Wall Spandrel Section with varied insulation (see F1 to F3 above) ^{2,3}					
7	Concrete Slab	8" (203)	12.5 (1.8)	-	140 (2250)	0.20 (850)
8	Mineral Wool Insulation	1" (25)	0.24 (0.034)	R-4.2 (0.74 RSI)	4 (64)	0.20 (850)
9	Exterior Film ¹	-	-	R-0.2 (0.03 RSI)	-	-

¹ Value selected from table 1, p. 26.1 of 2009 ASHRAE Handbook – Fundamentals depending on surface orientation

² The thermal conductivity of air spaces within framing was found using ISO 100077-2

³ For a window to wall ratio of 50%

AIM = Architectural Insulation Module

5.0 Steel-Frame Construction

Detail 5.1.1	A.5.1
Interior Insulated 3 5/8" x 1 5/8" Steel Stud Wall Assembly – Clear Wall	
Detail 5.1.2	A.5.2
Interior Insulated 6" x 1 5/8" Steel Stud Wall Assembly – Clear Wall	
Detail 5.1.3	A.5.3
Exterior Insulated 3 5/8" x 1 5/8" Steel Stud (16" o.c.) Drained EIFS Wall Assembly – Clear Wall	
Detail 5.1.4	A.5.4
Exterior and Interior Insulated 3 5/8" x 1 5/8" Steel Stud (16" o.c.) Drained EIFS Wall Assembly with R-12 Batt Insulation in Stud Cavity – Clear Wall	
Detail 5.1.5	A.5.5
Exterior Insulated 3 5/8" x 1 5/8" Steel Stud (16" o.c.) Wall Assembly with Vertical Z-Girts (16" o.c.) Supporting Metal Cladding – Clear Wall	
Detail 5.1.6	A.5.6
Exterior and Interior Insulated 6" x 1 5/8" Steel Stud (16" o.c.) Wall Assembly with Vertical Z-Girts (16" o.c.) Supporting Metal Cladding and R-20 Batt Insulation in Stud Cavity – Clear Wall	
Detail 5.1.7	A.5.7
Exterior and Interior Insulated 6" x 1 5/8" Steel Stud (16" o.c.) Wall Assembly with Vertical Z-Girts (16" o.c.) and 1 1/2" Spray Foam (R-9.8) in Stud Cavity – Clear Wall	
Detail 5.1.8	A.5.8
Exterior and Interior Insulated 6" x 1 5/8" Steel Stud (16" o.c.) Wall Assembly with Vertical Z-Girts (16" o.c.) and 2" Spray Foam (R-11.4) in Stud Cavity – Clear Wall	
Detail 5.1.9	A.5.9
Exterior Insulated 3 5/8" x 1 5/8" Steel Stud (16" o.c.) Wall Assembly with Horizontal Z-Girts (24" o.c.) Supporting Metal Cladding – Clear Wall	
Detail 5.1.10	A.5.10
Exterior and Interior Insulated 6" x 1 5/8" Steel Stud (16" o.c.) Wall Assembly with Horizontal Z-Girts (24" o.c.) Supporting Cladding, Owens Corning ThermaFiber RainBarrier HC Max Insulation and R-20 Batt Insulation in Stud Cavity – Clear Wall	
Detail 5.1.11	A.5.11
Exterior and Interior Insulated 6" x 1 5/8" Steel Stud (16" o.c.) Wall Assembly with Horizontal Z-Girts (24" o.c.) Supporting Cladding, Owens Corning ThermaFiber RainBarrier HC Plus 110 Insulation and R-20 Batt Insulation in Stud Cavity – Clear Wall	
Detail 5.1.12	A.5.12

Exterior and Interior Insulated 6" x 1 5/8" Steel Stud (16" o.c.) Wall Assembly with Horizontal Z-Girts (24" o.c.) Supporting Cladding, Owens Corning ThermaFiber RainBarrier 45 Insulation and R-20 Batt Insulation in Stud Cavity – Clear Wall

Detail 5.1.13A.5.13

Exterior and Interior Insulated 3 5/8" x 1 5/8" Steel Stud (16" o.c.) Wall Assembly with Vertical Z-girts (16" o.c.) Supporting Stucco Cladding and R-12 Batt Insulation in Stud Cavity – Clear Wall

Detail 5.1.14A.5.14

Exterior and Interior Insulated 3 5/8" x 1 5/8" Steel Stud (16" o.c.) Wall Assembly with Horizontal Z-Girts (24" o.c.) Supporting Metal Cladding and R-12 Batt Insulation in Stud Cavity – Clear Wall

Detail 5.1.15A.5.15

Exterior and Interior Insulated 6" x 1 5/8" Steel Stud (16" o.c.) Wall Assembly with Horizontal Z-Girts (24" o.c.) and 1 1/2" Spray Foam (R-9.8) in Stud Cavity – Clear Wall

Detail 5.1.16A.5.16

Exterior Insulated 3 5/8" x 1 5/8" Steel Stud (16" o.c.) Wall Assembly with Vertical Z-Girts (24" o.c.) & Horizontal Z-Girts (24" o.c.) Supporting Metal Cladding – Clear Wall

Detail 5.1.17A.5.17

Exterior Insulated 3 5/8" x 1 5/8" Steel Stud (16" o.c.) Wall Assembly with Intermittent Vertical Z-Girts (16" o.c.) Supporting Metal Cladding – Clear Wall

Detail 5.1.18A.5.18

Exterior Insulated 3 5/8" x 1 5/8" Steel Stud (16" o.c.) Wall Assembly with Horizontal Clips (24" o.c.) Supporting Metal Cladding – Clear Wall

Detail 5.1.19A.5.19

Exterior and Interior Insulated 3 5/8" x 1 5/8" Steel Stud (16" o.c.) Wall Assembly with Horizontal Clips (24" o.c.) Supporting Metal Cladding and R-12 Batt Insulation in Stud Cavity – Clear Wall

Detail 5.1.20A.5.20

Exterior and Interior Insulated 3 5/8" x 1 5/8" Steel Stud (16" o.c.) Wall Assembly with Vertical Z Clips (16" o.c.) Supporting Stucco Cladding and R-12 Batt Insulation in Stud Cavity – Clear Wall

Detail 5.1.21A.5.21

Exterior Insulated 6" x 1 5/8" Steel Stud (16" o.c.) Wall Assembly with Knight MFI-System (24" o.c.) Supporting Cladding – Clear Wall

Detail 5.1.22A.5.22

Exterior and Interior Insulated 6" x 1 5/8" Steel Stud (16" o.c.) Wall Assembly with Knight MFI-System (24" o.c.) Supporting Cladding and R-19 Batt Insulation in Stud Cavity – Clear Wall

Detail 5.1.23A.5.23

Exterior Insulated 3 5/8" x 1 5/8" Steel Stud (16" o.c.) Wall Assembly with CL-Talon 300 Clip System Supporting Cladding – Clear Wall	
Detail 5.1.24	A.5.24
Exterior Insulated 3 5/8" x 1 5/8" Steel Stud (16" o.c.) Wall Assembly with Thermally Broken Aluminum Clip Supporting Cladding – Clear Wall	
Detail 5.1.25	A.5.25
Exterior Insulated 3 5/8" x 1/58" Steel Stud (16"o.c.) Wall Assembly with TAC Fiber Reinforced Plastic Girts Supporting Cladding – Clear Wall	
Detail 5.1.26	A.5.26
Exterior Insulated 3 5/8" x 1 5/8" Steel Stud (16" o.c.) Wall Assembly with Thermally Broken Aluminum Clip Rail System (24" o.c.) Supporting Cladding – Clear Wall	
Detail 5.1.27	A.5.27
Exterior and Interior Insulated 6" x 1 5/8" Steel Stud (16" o.c.) Wall Assembly with High Compression Insulation and Through Insulation Steel Fasteners (12" o.c.) Supporting Cladding, Owens Corning ThermaFiber RainBarrier HC Max Insulation and R-20 Batt Insulation in Stud Cavity – Clear Wall	
Detail 5.1.28	A.5.28
Exterior and Interior Insulated 6" x 1 5/8" Steel Stud (16" o.c.) Wall Assembly with High Compression Insulation and Through Insulation Steel Fasteners (12" o.c.) Supporting Cladding, Owens Corning ThermaFiber RainBarrier HC Plus 110 Exterior Insulation and R-20 Batt Insulation in Stud Cavity – Clear Wall	
Detail 5.1.29	A.5.29
Exterior and Interior Insulated 6" x 1 5/8" Steel Stud (16" o.c.) Wall Assembly with High Compression Insulation and Through Insulation Steel Fasteners (12" o.c.) Supporting Cladding, Owens Corning ThermaFiber RainBarrier 45 Insulation and R-20 Batt Insulation in Stud Cavity – Clear Wall	
Detail 5.1.30	A.5.30
Exterior and Interior Insulated 6" x 1 5/8" Steel Stud (16" o.c.) Wall Assembly with High Compression Insulation and Through Insulation Steel Fasteners (12" o.c.) Supporting Cladding, Owens Corning ThermaFiber RainBarrier HC Max Insulation and R-22 Batt Insulation in Stud Cavity – Clear Wall	
Detail 5.1.31	A.5.31
Exterior and Interior Insulated 6" x 1 5/8" Steel Stud (16" o.c.) Wall Assembly with High Compression Insulation and Through Insulation Steel Fasteners (12" o.c.) Supporting Cladding, Owens Corning ThermaFiber RainBarrier HC Plus 110 Exterior Insulation and R-22 Batt Insulation in Stud Cavity – Clear Wall	
Detail 5.1.32	A.5.32
Exterior and Interior Insulated 6" x 1 5/8" Steel Stud (16" o.c.) Wall Assembly with High Compression Insulation and Through Insulation Steel Fasteners (12" o.c.) Supporting Cladding, Owens Corning ThermaFiber RainBarrier 45 Insulation and R-22 Batt Insulation in Stud Cavity – Clear Wall	

Detail 5.1.33	A.5.33
Exterior and Interior Insulated 6" x 1 5/8" Steel Stud (16" o.c.) Wall Assembly with High Compression Insulation and Through Insulation Steel Fasteners (12" o.c.) Supporting Cladding, Owens Corning ThermaFiber RainBarrier HC Max Insulation and R-24 Batt Insulation in Stud Cavity – Clear Wall	
Detail 5.1.34	A.5.34
Exterior and Interior Insulated 6" x 1 5/8" Steel Stud (16" o.c.) Wall Assembly with High Compression Insulation and Through Insulation Steel Fasteners (12" o.c.) Supporting Cladding, Owens Corning ThermaFiber RainBarrier HC Plus 110 Exterior Insulation and R-24 Batt Insulation in Stud Cavity – Clear Wall	
Detail 5.1.35	A.5.35
Exterior and Interior Insulated 6" x 1 5/8" Steel Stud (16" o.c.) Wall Assembly with High Compression Insulation and Through Insulation Steel Fasteners (12" o.c.) Supporting Cladding, Owens Corning ThermaFiber RainBarrier 45 Insulation and R-24 Batt Insulation in Stud Cavity – Clear Wall	
Detail 5.1.36	A.5.36
Exterior and Interior Insulated 6" x 1 5/8" Steel Stud (16" o.c.) Wall Assembly with Knight CI-System (8" o.c.) and 1 1/2" Spray Foam (R-9.8) in Stud Cavity – Clear Wall	
Detail 5.1.37	A.5.37
Exterior and Interior Insulated 6" x 1 5/8" Steel Stud (16" o.c.) Wall Assembly with Knight CI-System (16" o.c.) and 1 1/2" Spray Foam (R-9.8) in Stud Cavity – Clear Wall	
Detail 5.1.38	A.5.38
Exterior Insulated 6" x 1 5/8" Steel Stud (16" o.c.) Wall Assembly with Knight CI-System (8" o.c.) – Clear Wall	
Detail 5.1.39	A.5.39
Exterior Insulated 3 5/8" x 1 5/8" Steel Stud (16" o.c.) Wall Assembly with R-TEC CI Bracket System Supporting Vertical Sub-girts – Clear Wall	
Detail 5.1.40	A.5.40
Exterior and Interior Insulated 3 5/8" x 1 5/8" Steel Stud (16" o.c.) Wall Assembly with R-TEC CI Bracket System Supporting Vertical Sub-girts and R-13 Batt Insulation in Stud Cavity – Clear Wall	
Detail 5.1.41	A.5.41
Exterior Insulated 3 5/8" x 1 5/8" Steel Stud (16" o.c.) Wall Assembly with Thermally Broken ISO Clip System Supporting Vertical Sub-girts – Clear Wall	
Detail 5.1.42	A.5.42
Exterior Insulated 3 5/8" x 1 5/8" Steel Stud (16" o.c.) Wall Assembly with Thermally Broken ISO Clip System Supporting Horizontal Sub-girts – Clear Wall	
Detail 5.1.43	A.5.43

Exterior and Interior Insulated 3 5/8" x 1 5/8" Steel Stud (16" o.c.) Wall Assembly with Thermally Broken ISO Clip System Supporting Vertical Sub-girts and R-12 Batt Insulation in Stud Cavity – Clear Wall	
Detail 5.1.44	A.5.44
Exterior and Interior Insulated 3 5/8" x 1 5/8" Steel Stud (16" o.c.) Wall Assembly with Thermally Broken ISO Clip System Supporting Horizontal Sub-girts and R-12 Batt Insulation in Stud Cavity – Clear Wall	
Detail 5.1.45	A.5.45
Exterior Insulated 3 5/8" x 1 5/8" Steel Stud (16" o.c.) Wall Assembly with Thermally Broken ISO Clip System (16" o.c.) Supporting Horizontal and Vertical Sub-girts – Clear Wall	
Detail 5.1.46	A.5.46
Exterior Insulated 3 5/8" x 1 5/8" Steel Stud (16" o.c.) Wall Assembly with Thermally Broken ISO Clip System (32" o.c.) Supporting Horizontal and Vertical Sub-girts – Clear Wall	
Detail 5.1.47	A.5.47
Exterior Insulated 3 5/8" x 1 5/8" Steel Stud (16" o.c.) Wall Assembly with Nvelope – NV1 Clip System Supporting Cladding – Clear Wall	
Detail 5.1.48	A.5.48
Exterior and Interior Insulated 3 5/8" x 1 5/8" Steel Stud (16" o.c.) Wall Assembly with Nvelope – NV1 Clip System Supporting Cladding and R-12 Batt Insulation in Stud Cavity – Clear Wall	
Detail 5.1.49	A.5.49
Exterior and Interior Insulated 6" x 1 5/8" Steel Stud (16" o.c.) Wall Assembly with Nvelope – NV1 Clip System Supporting Cladding and R-19 Batt Insulation in Stud Cavity – Clear Wall	
Detail 5.1.50	A.5.50
Exterior and Interior Insulated 6" x 1 5/8" Slotted Steel R-Stud (16" o.c.) Wall Assembly with Nvelope – NV1 Clip System Supporting Cladding and R-19 Batt Insulation in Stud Cavity – Clear Wall	
Detail 5.1.51	A.5.51
Exterior and Interior Insulated 3 5/8" x 1 5/8" Steel Stud (16" o.c.) Wall Assembly with Nvelope – Eko Thermobacket Clip System Supporting Cladding and R-13 Batt Insulation in Stud Cavity – Clear Wall	
Detail 5.1.52	A.5.52
Exterior and Interior Insulated 3 5/8" x 1 5/8" Steel Stud (16" o.c.) Wall Assembly with Nvelope – Eko Thermobacket and NV1 Clip System Supporting Cladding and R-13 Batt Insulation in Stud Cavity – Clear Wall	
Detail 5.1.53	A.5.53
Exterior Insulated 3 5/8" x 1 5/8" Steel Stud (16" O.C.) Wall Assembly with Cascadia Clip Fiberglass Thermal Spacers – Clear Wall	

Detail 5.1.54	A.5.54
Exterior and Interior Insulated 6" x 1 5/8" Steel Stud (16" o.c. and 24" o.c.) Wall Assembly with Vertical Clips (24" o.c. and 36" o.c.) Supporting Cladding and Owens Corning R-20 Batt Insulation in Stud Cavity – Clear Wall	
Detail 5.1.55	A.5.55
Exterior and Interior Insulated 6" x 1 5/8" Steel Stud (16" o.c. and 24" o.c.) Wall Assembly with Vertical Clips (24" o.c. and 36" o.c.) Supporting Cladding and Owens Corning R-22.5 Batt Insulation in Stud Cavity– Clear Wall	
Detail 5.1.56	A.5.56
Exterior and Interior Insulated 6" x 1/58" Steel Stud (16" o.c. and 24" o.c.) Wall Assembly with Vertical Clips (24" o.c. and 36" o.c.) Supporting Cladding and Owens Corning R-24 Batt Insulation in Stud Cavity– Clear Wall	
Detail 5.1.57	A.5.57
Exterior Insulated 6" x 1 5/8" Steel Stud (16" o.c. and 24" o.c.) Wall Assembly with Vertical Clips (24" o.c. and 36" o.c.) Supporting Cladding – Clear Wall	
Detail 5.1.58	A.5.58
Owens Corning Exterior Insulated 6" x 1 5/8" Steel Stud (16" o.c.) Wall Assembly with Thermally Isolated Vertical Brackets and Rail System (24" o.c.) Supporting Metal Cladding – Clear Wall	
Detail 5.1.59	A.5.59
Exterior and Interior Insulated 6" x 1 5/8" Steel Stud (16" o.c. and 24" o.c.) Wall Assembly with Vertical Clips (24" o.c. and 36" o.c.) Supporting Cladding and R-20 Batt Insulation in Stud Cavity – Clear Wall	
Detail 5.1.60	A.5.60
Exterior and Interior Insulated 6" x 1 5/8" Steel Stud (16" o.c. and 24" o.c.) Wall Assembly with Steel Brick Anchors Supporting Brick Veneer and Owens Corning R-20 Batt Insulation in Stud Cavity – Clear Wall	
Detail 5.1.61	A.5.61
Exterior and Interior Insulated 6" x 1 5/8" Steel Stud (16" o.c. and 24" o.c.) Wall Assembly with Steel Brick Anchors Supporting Brick Veneer and Owens Corning R-22.5 Batt Insulation in Stud Cavity – Clear Wall	
Detail 5.1.62	A.5.62
Exterior and Interior Insulated 6" x 1 5/8" Steel Stud (16" o.c. and 24" o.c.) Wall Assembly with Steel Brick Anchors Supporting Brick Veneer and Owens Corning R-24 Batt Insulation in Stud Cavity – Clear Wall	
Detail 5.1.63	A.5.63
Exterior and Interior Insulated 6" x 1 5/8" Steel Stud (16" o.c.) Wall Assembly with Heckmann Pos-I-Tie Veneer Anchoring System Supporting Brick Veneer and Owens Corning R-20 Batt Insulation in Stud Cavity – Clear Wall	
Detail 5.1.64	A.5.64

- Exterior and Interior Insulated 6" x 1 5/8" Steel Stud (16" o.c.) Wall Assembly with Heckmann Pos-I-Tie Veneer Anchoring System Supporting Brick Veneer and Owens Corning R-22.5 Batt Insulation in Stud Cavity – Clear Wall
- Detail 5.1.65****A.5.65**
- Exterior and Interior Insulated 6" x 1 5/8" Steel Stud (16" o.c.) Wall Assembly with Heckmann Pos-I-Tie Veneer Anchoring System Supporting Brick Veneer and Owens Corning R-24 Batt Insulation in Stud Cavity – Clear Wall
- Detail 5.1.66****A.5.66**
- Exterior and Interior Insulated 6" x 1 5/8" Steel Stud (16" o.c.) Wall Assembly with Steel Anchor Supporting Brick Veneer, Owens Corning XPS Exterior Insulation and R-20 Batt Insulation in Stud Cavity – Clear Wall
- Detail 5.1.67****A.5.67**
- Exterior Insulated 3 5/8" x 1 5/8" Steel Stud (16" o.c.) Wall Assembly with Hohmann & Barnard Masonry Zinc 2-Seal Anchor Supporting Brick Veneer – Clear Wall
- Detail 5.1.68****A.5.68**
- Exterior Insulated 3 5/8" x 1 5/8" Steel Stud (16" o.c.) Wall Assembly with Hohmann & Barnard Masonry Stainless Steel 2-Seal Thermal Anchor Supporting Brick Veneer – Clear Wall
- Detail 5.1.69****A.5.69**
- Exterior Insulated 3 5/8" x 1 5/8" Steel Stud (16" o.c.) Wall Assembly with Hohmann & Barnard Masonry Stainless Steel 2-Seal Thermal Wing Nut Anchor Supporting Brick Veneer – Clear Wall
- Detail 5.1.70****A.5.70**
- Exterior Insulated 3 5/8" x 1 5/8" Steel Stud (16" o.c.) Wall Assembly with Hohmann & Barnard Masonry Carbon Steel X-Seal Anchor Supporting Brick Veneer – Clear Wall
- Detail 5.1.71****A.5.71**
- Exterior Insulated 3 5/8" x 1 5/8" Steel Stud (16" o.c.) Wall Assembly with Hohmann & Barnard Masonry Stainless Steel X-Seal Anchor Supporting Brick Veneer – Clear Wall
- Detail 5.1.72****A.5.72**
- Exterior Insulated 3 5/8" x 1 5/8" Steel Stud (16" o.c.) Wall Assembly with Hohmann & Barnard Masonry Carbon Steel HB-213 2X Anchor Supporting Brick Veneer – Clear Wall
- Detail 5.1.73****A.5.73**
- Exterior Insulated 3 5/8" x 1 5/8" Steel Stud (16" o.c.) Wall Assembly with Hohmann & Barnard Masonry Stainless Steel HB-213 2X Anchor Supporting Brick Veneer – Clear Wall
- Detail 5.1.74****A.5.74**

Exterior Insulated 3 5/8" x 1 5/8" Steel Stud (16" o.c.) Wall Assembly with Hohmann & Barnard Masonry Carbon Steel HB-200-X Anchor Supporting Brick Veneer – Clear Wall	
Detail 5.1.75	A.5.75
Exterior Insulated 3 5/8" x 1 5/8" Steel Stud (16" o.c.) Wall Assembly with Hohmann & Barnard Masonry Stainless Steel HB-200-X Anchor Supporting Brick Veneer – Clear Wall	
Detail 5.1.76	A.5.76
Exterior Insulated 3 5/8" x 1 5/8" Steel Stud (16" o.c.) Wall Assembly with Hohmann & Barnard Masonry Carbon Steel BL-407 Anchor Supporting Brick Veneer – Clear Wall	
Detail 5.1.77	A.5.77
Exterior Insulated 3 5/8" x 1 5/8" Steel Stud (16" o.c.) Wall Assembly with Hohmann & Barnard Masonry Stainless Steel BL-407 Anchor Supporting Brick Veneer – Clear Wall	
Detail 5.1.78	A.5.78
Exterior and Interior Insulated 6" x 1 5/8" Steel Stud (16" o.c. and 24" o.c.) Wall Assembly with Stainless Steel Brick Anchors Supporting Brick Veneer and R-20 Batt Insulation in Stud Cavity – Clear Wall	
Detail 5.1.79	A.5.79
Exterior and Interior Insulated 6" x 1 5/8" Steel Stud (16" o.c. and 24" o.c.) Wall Assembly with Steel Brick Anchors Supporting Brick Veneer and R-20 Batt Insulation in Stud Cavity – Clear Wall	
Detail 5.1.80	A.5.80
Exterior Insulated 6" x 1 5/8" Steel Stud (16" o.c.) Wall Assembly with ECO Cladding Alpha Vci Vertical System – Clear Wall	
Detail 5.1.81	A.5.81
Exterior and Interior Insulated 6" x 1 5/8" Steel Stud (16" o.c.) Wall Assembly with ECO Cladding Alpha Vci Vertical System and R-19 Batt Insulation in Stud Cavity – Clear Wall	
Detail 5.1.82	A.5.82
Exterior Insulated 6" x 1 5/8" Steel Stud (16" o.c.) Wall Assembly with ECO Cladding Alpha Hci Horizontal System – Clear Wall	
Detail 5.1.83	A.5.83
Exterior and Interior Insulated 6" x 1 5/8" Steel Stud (16" o.c.) Wall Assembly with ECO Cladding Alpha Hci Horizontal System and R-19 Batt Insulation in Stud Cavity – Clear Wall	
Detail 5.1.84	A.5.84
Exterior Insulated 3 5/8" x 1 5/8" Steel Stud (16" O.C.) Wall Assembly with Armadillo FRR Horizontal Z-Girts Supporting Cladding – Clear Wall	
Detail 5.1.85	A.5.85

Exterior and Interior Insulated 3 5/8" x 1 5/8" Steel Stud (16" O.C.) Wall Assembly with Armadillo FRR Horizontal Z-Girts Supporting Cladding and R-13 Batt Insulation in Stud Cavity – Clear Wall	
Detail 5.1.86	A.5.86
Exterior Insulated 3 5/8" x 1 5/8" Steel Stud (16" O.C.) Wall Assembly with Armadillo FRR Vertical Z-Girts Supporting Cladding – Clear Wall	
Detail 5.1.87	A.5.87
Exterior and Interior Insulated 3 5/8" x 1 5/8" Steel Stud (16" O.C.) Wall Assembly with Armadillo FRR Vertical Z-Girts Supporting Cladding and R-13 Batt Insulation in Stud Cavity – Clear Wall	
Detail 5.1.88	A.5.88
Exterior Insulated 3 5/8" x 1 5/8" Steel Stud (16" o.c.) Wall Assembly with Brick Ties (24" o.c.) Supporting Brick Veneer – Clear Wall	
Detail 5.1.89	A.5.89
Exterior Insulated 3 5/8" x 1 5/8" Steel Stud (16" o.c.) Wall Assembly with FERO Slotted Rap Ties (24" o.c.) Supporting Brick Veneer – Clear Wall	
Detail 5.1.90	A.5.90
Exterior Insulated 6" x 1 5/8" Steel Stud (16" O.C.) Wall Assembly with Fiber Reinforced Plastic Clip Supporting Cladding – Clear Wall	
Detail 5.1.91	A.5.91
Exterior and Interior Insulated 6" x 1 5/8" Steel Stud (16" O.C.) Wall Assembly with Fiber Reinforced Plastic Clip Supporting Metal Cladding and R-19 Batt in Stud Cavity – Clear Wall	
Detail 5.1.92	A.5.92
Exterior Insulated 6" x 1 5/8" Steel Stud (16" O.C.) Wall Assembly with Double Aluminum Bracket Supporting Metal Cladding	
Detail 5.1.93	A.5.93
Exterior and Interior Insulated 6" x 1 5/8" Steel Stud (16" O.C.) Wall Assembly with Double Aluminum Bracket Supporting Metal Cladding and R-19 Batt Insulation in Stud Cavity	
Detail 5.1.94	A.5.94
Exterior Insulated 6" x 1 5/8" Steel Stud (16" O.C.) Wall Assembly with Technoform Clip and Steel Fasteners - Clear Wall	
Detail 5.1.95	A.5.95
Exterior Insulated 6" x 1 5/8" Steel Stud (16" O.C.) Wall Assembly with Technoform Clip and Stainless Steel Fasteners - Clear Wall	
Detail 5.1.96	A.5.96
Exterior and Interior Insulated 6" x 1 5/8" Steel Stud (16" o.c.) Wall Assembly with Galvanized Horizontal Intermittent Clips (24" o.c.) Supporting Metal Cladding and Owens Corning R-20 Batt Insulation in Stud Cavity – Clear Wall	

Detail 5.1.97	A.5.97
Exterior and Interior Insulated 6" x 1 5/8" Steel Stud (16" o.c.) Wall Assembly with Galvanized Horizontal Intermittent Clips (24" o.c.) Supporting Metal Cladding and Owens Corning R-22.5 Batt Insulation in Stud Cavity – Clear Wall	
Detail 5.1.98	A.5.98
Exterior and Interior Insulated 6" x 1 5/8" Steel Stud (16" o.c.) Wall Assembly with Galvanized Horizontal Intermittent Clips (24" o.c.) Supporting Metal Cladding and Owens Corning R-24 Batt Insulation in Stud Cavity – Clear Wall	
Detail 5.1.99	A.5.99
Exterior Insulated 6" x 1 5/8" Steel Stud (16" o.c.) Wall Assembly with EJOT Crossfix Console and Horizontal Rail System Supporting Metal Cladding - Clear Wall	
Detail 5.1.100	A.5.100
Exterior and Interior Insulated 6" x 1 5/8" Steel Stud (16" o.c.) Wall Assembly with EJOT Crossfix Console and Horizontal Rail System Supporting Metal Cladding and R-20 Batt Insulation in Stud Cavity - Clear Wall	
Detail 5.1.101	A.5.101
Exterior Insulated 6" x 1 5/8" Steel Stud (24" o.c.) Wall Assembly with EJOT Crossfix Console and Horizontal Rail System Supporting Metal Cladding - Clear Wall	
Detail 5.1.102	A.5.102
Exterior and Interior Insulated 6" x 1 5/8" Steel Stud (24" o.c.) Wall Assembly with EJOT Crossfix Console and Horizontal Rail System Supporting Metal Cladding and R-20 Batt Insulation in Stud Cavity - Clear Wall	
Detail 5.1.103	A.5.103
Exterior Insulated 6" x 1 5/8" Steel Stud (16" o.c.) Wall Assembly with EJOT Crossfix Console and Vertical Rail System Supporting Metal Cladding - Clear Wall	
Detail 5.1.104	A.5.104
Exterior and Interior Insulated 6" x 1 5/8" Steel Stud (16" o.c.) Wall Assembly with EJOT Crossfix Console and Vertical Rail System Supporting Metal Cladding and R-20 Batt Insulation in Stud Cavity - Clear Wall	
Detail 5.1.105	A.5.105
Exterior Insulated 6" x 1 5/8" Steel Stud (24" o.c.) Wall Assembly with EJOT Crossfix Console and Vertical Rail System Supporting Metal Cladding - Clear Wall	
Detail 5.1.106	A.5.106
Exterior and Interior Insulated 6" x 1 5/8" Steel Stud (24" o.c.) Wall Assembly with EJOT Crossfix Console and Vertical Rail System Supporting Metal Cladding and R-20 Batt Insulation in Stud Cavity - Clear Wall	
Detail 5.1.107	A.5.107

Exterior Insulated 6" x 1 5/8" Steel Stud (16" o.c.) Wall Assembly with Horizontal Z-Girts (24" o.c.) Supporting Cladding and Owens Corning ThermaFiber RainBarrier HC Max Insulation – Clear Wall	
Detail 5.1.108	A.5.108
Exterior Insulated 6" x 1 5/8" Steel Stud (16" o.c.) Wall Assembly with High Compression Insulation and Through Insulation Steel Fasteners (12" o.c.) Supporting Cladding, Owens Corning ThermaFiber RainBarrier HC Max Insulation – Clear Wall	
Detail 5.1.109	A.5.109
Exterior Insulated 6" x 1 5/8" Steel Stud (16" o.c.) Wall Assembly with High Compression Insulation and Through Insulation Steel Fasteners (12" o.c.) Supporting Cladding, Owens Corning ThermaFiber RainBarrier Ci HC 80/45 Insulation – Clear Wall	
Detail 5.1.110	A.5.110
Exterior Insulated 6" x 1 5/8" Steel Stud (16" o.c.) Wall Assembly with High Compression Insulation and Through Insulation Stainless Steel Fasteners (12" o.c.) Supporting Cladding, Owens Corning ThermaFiber RainBarrier HC Max Insulation – Clear Wall	
Detail 5.1.111	A.5.111
Exterior Insulated 6" x 1 5/8" Steel Stud (16" o.c.) Wall Assembly with High Compression Insulation and Through Insulation Stainless Steel Fasteners (12" o.c.) Supporting Cladding, Owens Corning ThermaFiber RainBarrier Ci HC 80/45 Insulation – Clear Wall	
Detail 5.1.112	A.5.112
Exterior and Interior Insulated 6" x 1 5/8" Steel Stud (16" o.c.) Wall Assembly with High Compression Insulation and Through Insulation Stainless Steel Fasteners (16" o.c.) Supporting Cladding, Owens Corning ThermaFiber RainBarrier HC Max Insulation and R-20 Batt Insulation in Stud Cavity – Clear Wall	
Detail 5.1.113	A.5.113
Exterior and Interior Insulated 6" x 1 5/8" Steel Stud (16" o.c.) Wall Assembly with High Compression Insulation and Through Insulation Stainless Steel Fasteners (16" o.c.) Supporting Cladding, Owens Corning ThermaFiber RainBarrier Ci HC 80/45 Insulation and R-20 Batt Insulation in Stud Cavity – Clear Wall	
Detail 5.1.114	A.5.114
Exterior and Interior Insulated Wall Assembly with Brick Ties Supporting Brick Veneer and R-12 Batt Insulation in Stud Cavity – Clear Wall	
Detail 5.1.115	A.5.115
Exterior Insulated 6" x 1 5/8" Steel Stud (16" o.c.) Wall Assembly with SOPREMA SOPRA-XPS 20 and ACS-S Thermal Clip Supporting Metal Cladding - Clear Wall	
Detail 5.1.116	A.5.116

Exterior Insulated 6" x 1 5/8" Steel Stud (24" o.c.) Wall Assembly with SOPREMA SOPRA-XPS 20 and ACS-S Thermal Clip Supporting Metal Cladding - Clear Wall	
Detail 5.1.117	A.5.117
Exterior Insulated 6" x 1 5/8" Steel Stud (16" o.c.) Wall Assembly with SOPREMA SOPRA-SPF 202 and ACS-S Thermal Clip Supporting Metal Cladding - Clear Wall	
Detail 5.1.118	A.5.118
Exterior Insulated 6" x 1 5/8" Steel Stud (24" o.c.) Wall Assembly with SOPREMA SOPRA-SPF 202 and ACS-S Thermal Clip Supporting Metal Cladding - Clear Wall	
Detail 5.1.119	A.5.119
Exterior Insulated 6" x 1 5/8" Steel Stud (16" o.c.) Wall Assembly with SOPREMA SOPRA-ISO V ALU and ACS-S Thermal Clip Supporting Metal Cladding - Clear Wall	
Detail 5.1.120	A.5.120
Exterior Insulated 6" x 1 5/8" Steel Stud (24" o.c.) Wall Assembly with SOPREMA SOPRA-ISO V ALU and ACS-S Thermal Clip Supporting Metal Cladding - Clear Wall	
Detail 5.1.121	A.5.121
Exterior Insulated 6" x 1 5/8" Steel Stud (16" o.c.) Wall Assembly with Mineral Wool and ACS-S Thermal Clip Supporting Metal Cladding - Clear Wall	
Detail 5.1.122	A.5.122
Exterior Insulated 6" x 1 5/8" Steel Stud (24" o.c.) Wall Assembly with Mineral Wool and ACS-S Thermal Clip Supporting Metal Cladding - Clear Wall	
Detail 5.1.123	A.5.123
Exterior and Interior Insulated 6" x 1 5/8" Steel Stud (16" o.c.) Wall Assembly with SOPREMA SOPRA-XPS 20 and ACS-S Thermal Clip Supporting Metal Cladding with R-20 Cellulose Insulation in Stud Cavity - Clear Wall	
Detail 5.1.124	A.5.124
Exterior and Interior Insulated 6" x 1 5/8" Steel Stud (24" o.c.) Wall Assembly with SOPREMA SOPRA-XPS 20 and ACS-S Thermal Clip Supporting Metal Cladding with R-20 Cellulose Insulation in Stud Cavity - Clear Wall	
Detail 5.1.125	A.5.125
Exterior and Interior Insulated 6" x 1 5/8" Steel Stud (16" o.c.) Wall Assembly with SOPREMA SOPRA-SPF 202 and ACS-S Thermal Clip Supporting Metal Cladding with R-20 Cellulose Insulation in Stud Cavity - Clear Wall	
Detail 5.1.126	A.5.126
Exterior and Interior Insulated 6" x 1 5/8" Steel Stud (24" o.c.) Wall Assembly with SOPREMA SOPRA-SPF 202 and ACS-S Thermal Clip Supporting Metal Cladding with R-20 Cellulose Insulation in Stud Cavity - Clear Wall	

Detail 5.1.127	A.5.127
Exterior and Interior Insulated 6" x 1 5/8" Steel Stud (16" o.c.) Wall Assembly with SOPREMA SOPRA-ISO V PLUS and ACS-S Thermal Clip Supporting Metal Cladding with R-20 Cellulose Insulation in Stud Cavity - Clear Wall	
Detail 5.1.128	A.5.128
Exterior and Interior Insulated 6" x 1 5/8" Steel Stud (24" o.c.) Wall Assembly with SOPREMA SOPRA-ISO V PLUS and ACS-S Thermal Clip Supporting Metal Cladding with R-20 Cellulose Insulation in Stud Cavity - Clear Wall	
Detail 5.1.129	A.5.129
Exterior and Interior Insulated 6" x 1 5/8" Steel Stud (16" o.c.) Wall Assembly with Mineral Wool and ACS-S Thermal Clip Supporting Metal Cladding with R-20 Cellulose Insulation in Stud Cavity - Clear Wall	
Detail 5.1.130	A.5.130
Exterior and Interior Insulated 6" x 1 5/8" Steel Stud (24" o.c.) Wall Assembly with Mineral Wool and ACS-S Thermal Clip Supporting Metal Cladding with R-20 Cellulose Insulation in Stud Cavity - Clear Wall	
Detail 5.1.131	A.5.131
Exterior Insulated 6" x 1 5/8" Steel Stud (16" o.c.) Wall Assembly with Protected SOPREMA SOPRA-ISO V ALU and ACS-S Thermal Clip Supporting Metal Cladding - Clear Wall	
Detail 5.1.132	A.5.132
Exterior Insulated 6" x 1 5/8" Steel Stud (24" o.c.) Wall Assembly with Protected SOPREMA SOPRA-ISO V ALU and ACS-S Thermal Clip Supporting Metal Cladding - Clear Wall	
Detail 5.1.133	A.5.133
Exterior and Interior Insulated 6" x 1 5/8" Steel Stud (16" o.c.) Wall Assembly with Protected SOPREMA SOPRA-ISO V PLUS and ACS-S Thermal Clip Supporting Metal Cladding with R-20 Cellulose Insulation in Stud Cavity - Clear Wall	
Detail 5.1.134	A.5.134
Exterior and Interior Insulated 6" x 1 5/8" Steel Stud (24" o.c.) Wall Assembly with Protected SOPREMA SOPRA-ISO V PLUS and ACS-S Thermal Clip Supporting Metal Cladding with R-20 Cellulose Insulation in Stud Cavity - Clear Wall	
Detail 5.1.135	A.5.135
Exterior Insulated 6" x 1 5/8" Steel Stud (16" o.c.) Wall Assembly with U-Kon ND-062 Brackets and Vertical Rail System Supporting Metal Cladding - Clear Wall	
Detail 5.2.1	A.5.136
Exterior Insulated 3 5/8" x 1 5/8" Steel Stud (16" o.c.) Wall Assembly with Horizontal Z-Girts (24" o.c.) Supporting Metal Cladding – Intermediate Floor Intersection	
Detail 5.2.2	A.5.137

Exterior Insulated 3 5/8" x 1 5/8" Steel Stud (16" o.c.) Wall Assembly with Horizontal Z-Girts (24" o.c.) Supporting Metal Cladding – Intermediate Floor Intersection with Top Side Insulation	
Detail 5.2.3	A.5.138
Exterior Insulated 3 5/8" x 1 5/8" Steel Stud (16" o.c.) Wall Assembly with Horizontal Z-Girts (24" o.c.) Supporting Metal Cladding – Intermediate Floor Intersection with Top & Under Side Insulation	
Detail 5.2.4	A.5.139
Exterior Insulated 3 5/8" x 1 5/8" Steel Stud (16" o.c.) Wall Assembly with Horizontal Z-girts (24" o.c.) Supporting Metal Cladding – Uninsulated Intermediate Floor Intersection with Uninsulated Curb	
Detail 5.2.5	A.5.140
Exterior and Interior Insulated 3 5/8" x 1 5/8" Steel Stud (16" o.c.) Wall Assembly with Horizontal Z-girts (24" o.c.) Supporting Metal Cladding and R-12 Batt Insulation in Stud Cavity – Uninsulated Intermediate Floor Intersection with Uninsulated Curb	
Detail 5.2.6	A.5.141
Exterior Insulated 3 5/8" x 1 5/8" Steel Stud (16" o.c.) Wall Assembly with Horizontal Z-girts (24" o.c.) Supporting Metal Cladding – Uninsulated Intermediate Floor Intersection with Insulated Curb	
Detail 5.2.7	A.5.142
Exterior and Interior Insulated 3 5/8" x 1 5/8" Steel Stud (16" o.c.) Wall Assembly with Horizontal Z-girts (24" o.c.) Supporting Metal Cladding and R-12 Batt Insulation in Stud Cavity – Uninsulated Intermediate Floor Intersection with Insulated Curb	
Detail 5.2.8	A.5.143
Exterior and Interior Insulated 3 5/8" x 1 5/8" Steel Stud (16" o.c.) Wall Assembly with Vertical Z Girts (16" o.c.) Supporting Stucco Cladding and R-12 Batt Insulation in Stud Cavity – Uninsulated Intermediate Floor Intersection	
Detail 5.2.9	A.5.144
Exterior Insulated 3 5/8" x 1 5/8" Steel Stud (16" o.c.) Drained EIFS Wall Assembly – Isokorb CM20 Thermally Broken Slab Projection without Concrete Curb	
Detail 5.2.10	A.5.145
Exterior and Interior Insulated 3 5/8" x 1 5/8" Steel Stud (16" o.c.) Drained EIFS Wall Assembly with R-12 Batt Insulation in Stud Cavity – Isokorb CM20 Thermally Broken Slab Projection without Concrete Curb	
Detail 5.2.11	A.5.146
Exterior and Interior Insulated 3 5/8" x 1 5/8" Steel Stud (16" o.c.) Wall Assembly with Horizontal Z-girts (24" o.c.) Supporting Metal Cladding and R-12 Batt Insulation in Stud Cavity – Isokorb CM20 Thermally Broken Slab Projection with Uninsulated Curb	

Detail 5.2.12	A.5.147
Exterior Insulated 3 5/8" x 1 5/8" Steel Stud (16" o.c.) Wall Assembly with Horizontal Z-girts (24" o.c.) Supporting Metal Cladding – Isokorb CM20 Thermally Broken Slab Projection with Uninsulated Curb	
Detail 5.2.13	A.5.148
Exterior Insulated 3 5/8" x 1 5/8" Steel Stud (16" o.c.) Wall Assembly with Horizontal Z-girts (24" o.c.) Supporting Metal Cladding – Isokorb CM20 Thermally Broken Slab Projection with Insulated Curb	
Detail 5.2.14	A.5.149
Exterior and Interior Insulated 3 5/8" x 1 5/8" Steel Stud (16" o.c.) Wall Assembly with Horizontal Z-girts (24" o.c.) Supporting Metal Cladding and R-12 Batt Insulation in Stud Cavity – Isokorb CM20 Thermally Broken Slab Projection with Insulated Curb	
Detail 5.2.15	A.5.150
Exterior Insulated 3 5/8" x 1 5/8" Steel Stud (16" o.c.) Drained EIFS Wall Assembly – Intermediate Floor Intersection	
Detail 5.2.16	A.5.151
Exterior and Interior Insulated 3 5/8" x 1 5/8" Steel Stud (16" o.c.) Drained EIFS Wall Assembly with R-12 Batt Insulation in Stud Cavity – Intermediate Floor Intersection	
Detail 5.2.17	A.5.152
Exterior Insulated 3 5/8" x 1 5/8" Steel Stud (16" o.c.) Wall Assembly with Thermally Broken ISO Clip System Supporting Vertical Sub-girts – Intermediate Concrete Floor Intersection	
Detail 5.2.18	A.5.153
Exterior Insulated 3 5/8" x 1 5/8" Steel Stud (16" o.c.) Wall Assembly with Thermally Broken ISO Clip System Supporting Horizontal Sub-girts – Intermediate Concrete Floor Intersection	
Detail 5.2.19	A.5.154
Exterior and Interior Insulated 3 5/8" x 1 5/8" Steel Stud (16" o.c.) Wall Assembly with Vertical Z-girts (16" o.c.) Supporting Stucco Cladding and R-12 Batt Insulation in Stud Cavity – Steel Framed Floor with Cross Cavity Flashing	
Detail 5.2.20	A.5.155
Exterior Insulated 3 5/8" x 1 5/8" Steel Stud (16" o.c.) Wall Assembly with Fiberglass Spacer and Through Insulation Fasteners Supporting Cladding – Insulated Intermediate Floor Intersection	
Detail 5.2.21	A.5.156
Exterior Insulated 3 5/8" x 1 5/8" Steel Stud (16" o.c.) Wall Assembly with Thermally Isolated Aluminum Clip Horizontal Sub-girt System Supporting Cladding – Intermediate Floor Intersection	
Detail 5.2.22	A.5.157

Exterior Insulated 3 5/8" x 1/58" Steel Stud (16"o.c.) Wall Assembly with TAC Fiber Reinforced Plastic Girts Supporting Cladding – Intermediate Floor Intersection	
Detail 5.2.23	A.5.158
Exterior Insulated 3 5/8" x 1 5/8" Steel Stud (16" o.c.) Wall Assembly with Thermally Broken Aluminum Clip Rail System (24" o.c.) Supporting Cladding – Intermediate Floor Intersection	
Detail 5.2.24	A.5.159
Exterior and Interior Insulated 3 5/8" x 1 5/8" Steel Stud (16" o.c.) Wall Assembly with Horizontal Z-Girts (24" o.c.) Supporting Metal Cladding and R-12 Batt Insulation in Stud Cavity – Structural Steel Framed Floor Intersection	
Detail 5.2.25	A.5.160
Interior Insulated 3 5/8" x 1 5/8" Steel Stud (16" o.c.) Wall Assembly with Horizontal Z-Girts (24" o.c.) Supporting Metal Cladding and R-12 Batt Insulation in Stud Cavity – Structural Steel Framed Floor Intersection	
Detail 5.2.26	A.5.161
Exterior and Interior Insulated Wall Assembly with Shelf Angle & Brick Ties Supporting Brick Veneer and R-12 Batt Insulation in Stud Cavity – Intermediate Floor Intersection	
Detail 5.2.27	A.5.162
Exterior and Interior Insulated Wall Assembly with Spaced Shelf Angle & Brick Ties Supporting Brick Veneer and R-12 Batt Insulation in Stud Cavity – Intermediate Floor Intersection	
Detail 5.2.28	A.5.163
Exterior and Interior Insulated Wall Assembly with Stainless Steel Shelf Angle & Brick Ties Supporting Brick Veneer and R-12 Batt Insulation in Stud Cavity – Intermediate Floor Intersection	
Detail 5.2.29	A.5.164
Exterior and Interior Insulated Wall Assembly with Thermally Broken Steel Shelf Angle & Brick Ties Supporting Brick Veneer and R-12 Batt Insulation in Stud Cavity – Slab Intersection	
Detail 5.2.30	A.5.165
Exterior Insulated 3 5/8" x 1 5/8" Steel Stud Wall Assembly with Horizontal Z-girts Supporting Metal Cladding – Armatherm 500 Thermally Broken Slab Projection with Insulated Curb	
Detail 5.2.31	A.5.166
Exterior Insulated 3 5/8" x 1 5/8" Steel Stud Wall Assembly with Armatherm Z-girts Supporting Metal Cladding – Armatherm 500-080 Thermally Broken Slab Projection with Insulated Curb	
Detail 5.2.32	A.5.167

- Exterior and Interior Insulated 3 5/8" x 1 5/8" Steel Stud (16" o.c.) Wall Assembly with Nvelope – Eko Thermobacket and NV1 Clip System Supporting Cladding and R-13 Batt Insulation in Stud Cavity – Intermediate Floor Intersection
- Detail 5.2.33****A.5.168**
- Exterior Insulated 3 5/8" x 1 5/8" Steel Stud (16" o.c.) Wall Assembly with FERO Slotted Rap Ties (24" o.c.) and FERO FAST Thermal Bracket (48" o.c.) Supporting Brick Veneer – Intermediate Floor Intersection
- Detail 5.2.34****A.5.169**
- Owens Corning Exterior Insulated 6" x 1 5/8" Steel Stud (16" o.c.) Wall Assembly with Thermally Isolated Vertical Brackets and Rail System (24" o.c.) Supporting Metal Cladding – Intermediate Floor Intersection
- Detail 5.2.35****A.5.170**
- Exterior and Interior Insulated 6" x 1 5/8" Steel Stud (16" o.c.) Wall Assembly with Thermally Isolated Vertical Brackets and Rail System (24" o.c.) Supporting Metal Cladding and Owens Corning R-20 Batt in Stud Cavity – Intermediate Floor Intersection
- Detail 5.2.36****A.5.171**
- Exterior and Interior Insulated 6" x 1 5/8" Steel Stud (16" o.c.) Wall Assembly with Thermally Isolated Vertical Brackets and Rail System (24" o.c.) Supporting Metal Cladding and Owens Corning R-22.5 Batt in Stud Cavity – Intermediate Floor Intersection
- Detail 5.2.37****A.5.172**
- Exterior and Interior Insulated 6" x 1 5/8" Steel Stud (16" o.c.) Wall Assembly with Thermally Isolated Vertical Brackets and Rail System (24" o.c.) Supporting Metal Cladding and Owens Corning R-24 Batt in Stud Cavity – Intermediate Floor Intersection
- Detail 5.2.38****A.5.173**
- Exterior Insulated 6" x 1 5/8" Steel Stud (16" o.c.) Wall Assembly with FRP Vertical Brackets and Rail System Supporting Metal Cladding – Intermediate Floor Intersection
- Detail 5.2.39****A.5.174**
- Exterior and Interior Insulated 6" x 1 5/8" Steel Stud (16" o.c.) Wall Assembly with FRP Vertical Brackets and Rail System Supporting Metal Cladding and R-19 Batt in Stud Cavity – Intermediate Floor Intersection
- Detail 5.2.40****A.5.175**
- Exterior Insulated 3 5/8" x 1 5/8" Steel Stud (16" o.c.) Wall Assembly with Horizontal Z-girts (24" o.c.) Supporting Metal Cladding – Isokorb K65-V8 Thermally Broken Slab Projection with Insulated Curb
- Detail 5.2.41****A.5.176**
- Exterior Insulated 3 5/8" x 1 5/8" Steel Stud (16" o.c.) Wall Assembly with Horizontal Z-girts (24" o.c.) Supporting Metal Cladding – Isokorb K10-V6 Thermally Broken Slab Projection with Insulated Curb

Detail 5.2.42	A.5.177
Exterior Insulated 3 5/8" x 1 5/8" Steel Stud (16" o.c.) Wall Assembly with Horizontal Z-girts (24" o.c.) Supporting Metal Cladding – Isokorb KXT65-V8 Thermally Broken Slab Projection with Insulated Curb	
Detail 5.2.43	A.5.178
Exterior Insulated 3 5/8" x 1 5/8" Steel Stud (16" o.c.) Wall Assembly with Horizontal Z-girts (24" o.c.) Supporting Metal Cladding – Isokorb KXT15-V6 Thermally Broken Slab Projection with Insulated Curb	
Detail 5.2.44	A.5.179
Exterior and Interior Insulated 3 5/8" x 1 5/8" Steel Stud (16" o.c.) Wall Assembly with Horizontal Z-girts (24" o.c.) Supporting Metal Cladding and R-12 Batt Insulation in Stud Cavity – Isokorb K65-V8 Thermally Broken Slab Projection with Insulated Curb	
Detail 5.2.45	A.5.180
Exterior and Interior Insulated 3 5/8" x 1 5/8" Steel Stud (16" o.c.) Wall Assembly with Horizontal Z-girts (24" o.c.) Supporting Metal Cladding and R-12 Batt Insulation in Stud Cavity – Isokorb K10-V6 Thermally Broken Slab Projection with Insulated Curb	
Detail 5.2.46	A.5.181
Exterior and Interior Insulated 3 5/8" x 1 5/8" Steel Stud (16" o.c.) Wall Assembly with Horizontal Z-girts (24" o.c.) Supporting Metal Cladding and R-12 Batt Insulation in Stud Cavity – Isokorb KXT65-V8 Thermally Broken Slab Projection with Insulated Curb	
Detail 5.2.47	A.5.182
Exterior and Interior Insulated 3 5/8" x 1 5/8" Steel Stud (16" o.c.) Wall Assembly with Horizontal Z-girts (24" o.c.) Supporting Metal Cladding and R-12 Batt Insulation in Stud Cavity – Isokorb KXT15-V6 Thermally Broken Slab Projection with Insulated Curb	
Detail 5.2.48	A.5.183
Exterior and Interior Insulated Wall Assembly with Stainless Steel Spaced Shelf Angle & Brick Ties Supporting Brick Veneer and R-12 Batt Insulation in Stud Cavity – Intermediate Floor Intersection	
Detail 5.2.49	A.5.184
Exterior and Interior Insulated Wall Assembly with Thermally Broken Stainless Steel Shelf Angle & Brick Ties Supporting Brick Veneer and R-12 Batt Insulation in Stud Cavity – Slab Intersection	
Detail 5.2.50	A.5.185
Exterior and Interior Insulated Wall Assembly with Stainless Steel Spaced Shelf Angle Without Flashing & Brick Ties Supporting Brick Veneer – Intermediate Floor Intersection	
Detail 5.2.51	A.5.186

Exterior Insulated 6" x 1 5/8" Steel Stud (16" o.c.) Wall Assembly with U-Kon ND 0-33 Bracket and Vertical Rail System Supporting Metal Cladding – Intermediate Floor Intersection	
Detail 5.3.1	A.5.187
Exterior Insulated 3 5/8" x 1 5/8" Steel Stud (16" o.c.) Drained EIFS Wall Assembly – Window and Intermediate Floor Intersection	
Detail 5.3.2	A.5.188
Exterior and Interior Insulated 3 5/8" x 1 5/8" Steel Stud (16" o.c.) Drained EIFS Wall Assembly with R-12 Batt Insulation in Stud Cavity – Window and Intermediate Floor Intersection	
Detail 5.3.3	A.5.189
Exterior Insulated 3 5/8" x 1 5/8" Steel Stud (16" o.c.) Drained EIFS Wall Assembly – Window with Aerogel and Intermediate Floor Intersection	
Detail 5.3.4	A.5.190
Exterior and Interior Insulated 3 5/8" x 1 5/8" Steel Stud (16" o.c.) Drained EIFS Wall Assembly with R-12 Batt Insulation in Stud Cavity – Window with Aerogel and Floor Slab Intersection	
Detail 5.3.5	A.5.191
Exterior Insulated 3 5/8" x 1 5/8" Steel Stud (16" o.c.) Wall Assembly with Horizontal Z-Girts (24" o.c.) Supporting Metal Cladding – Window & Intermediate Floor Intersection	
Detail 5.3.6	A.5.192
Exterior and Interior Insulated 3 5/8" x 1 5/8" Steel Stud (16" o.c.) Wall Assembly with Horizontal Z-girts (24" o.c.) Supporting Metal Cladding and R-12 Batt Insulation in Stud Cavity – Window and Intermediate Floor Intersection	
Detail 5.3.7	A.5.193
Exterior and Interior Insulated 3 5/8" x 1 5/8" Steel Stud (16" o.c.) Wall Assembly with Vertical Z Girts (16" o.c.) Supporting Stucco Cladding and R-12 Batt Insulation in Stud Cavity – Window and Intermediate Floor Intersection	
Detail 5.3.8	A.5.194
Interior Insulated Steel Frame Wall Assembly with Brick Cladding – Window Intersection	
Detail 5.3.9	A.5.195
Interior Insulated Steel Frame Wall Assembly with Brick Cladding – Window Intersection Aligned with Insulation	
Detail 5.3.10	A.5.196
Exterior Insulated 6" x 1 5/8" Steel Stud (16" o.c.) Wall Assembly with Thermally Isolated Vertical Brackets and Rail System (24" o.c.) Supporting Metal Cladding – Triple Glazed Aluminum Window & Intermediate Floor Intersection with Window Thermal Break Positioned in Steel Framing	
Detail 5.3.11	A.5.197

Exterior and Interior Insulated 6" x 1 5/8" Steel Stud (16" o.c.) Wall Assembly with Thermally Isolated Vertical Brackets and Rail System (24" o.c.) Supporting Metal Cladding and R-19 Batt Insulation in Stud Cavity – Triple Glazed Aluminum Window & Intermediate Floor Intersection with Window Thermal Break Positioned in Steel Framing	
Detail 5.3.12	A.5.198
Exterior Insulated 6" x 1 5/8" Steel Stud (16" o.c.) Wall Assembly with Thermally Isolated Vertical Brackets and Rail System (24" o.c.) Supporting Metal Cladding – Triple Glazed Aluminum Curtain Wall & Intermediate Floor Intersection with Window Thermal Break Positioned in the Exterior Insulation	
Detail 5.3.13	A.5.199
Exterior and Interior Insulated 6" x 1 5/8" Steel Stud (16" o.c.) Wall Assembly with Thermally Isolated Vertical Brackets and Rail System (24" o.c.) Supporting Metal Cladding and R-19 Batt Insulation in Stud Cavity – Triple Glazed Aluminum Curtain Wall & Intermediate Floor Intersection with Window Thermal Break Positioned in the Exterior Insulation	
Detail 5.3.14	A.5.200
Owens Corning Exterior Insulated 6" x 1 5/8" Steel Stud (16" o.c.) Wall Assembly with Thermally Isolated Vertical Brackets and Rail System (24" o.c.) Supporting Metal Cladding – Double Glazed Aluminum Window and Intermediate Floor Intersection	
Detail 5.3.15	A.5.201
Exterior and Interior Insulated 6" x 1 5/8" Steel Stud (16" o.c.) Wall Assembly with Thermally Isolated Vertical Brackets and Rail System (24" o.c.) Supporting Metal Cladding and Owens Corning R-20 Batt in Stud Cavity – Double Glazed Aluminum Window and Intermediate Floor Intersection	
Detail 5.3.16	A.5.202
Exterior and Interior Insulated 6" x 1 5/8" Steel Stud (16" o.c.) Wall Assembly with Thermally Isolated Vertical Brackets and Rail System (24" o.c.) Supporting Metal Cladding and Owens Corning R-22.5 Batt in Stud Cavity – Double Glazed Aluminum Window and Intermediate Floor Intersection	
Detail 5.3.17	A.5.203
Owens Corning Exterior Insulated 6" x 1 5/8" Steel Stud (16" o.c.) Wall Assembly with Thermally Isolated Vertical Brackets and Rail System (24" o.c.) Supporting Metal Cladding – Triple Glazed Aluminum Window and Intermediate Floor Intersection	
Detail 5.3.18	A.5.204
Exterior and Interior Insulated 6" x 1 5/8" Steel Stud (16" o.c.) Wall Assembly with Thermally Isolated Vertical Brackets and Rail System (24" o.c.) Supporting Metal Cladding and Owens Corning R-20 Batt in Stud Cavity – Triple Glazed Aluminum Window and Intermediate Floor Intersection	
Detail 5.3.19	A.5.205

Exterior and Interior Insulated 6" x 1 5/8" Steel Stud (16" o.c.) Wall Assembly with Thermally Isolated Vertical Brackets and Rail System (24" o.c.) Supporting Metal Cladding and Owens Corning R-22.5 Batt in Stud Cavity – Triple Glazed Aluminum Window and Intermediate Floor Intersection	
Detail 5.3.20	A.5.206
Exterior Insulated 6" x 1 5/8" Steel Stud (16" o.c.) Wall Assembly with FRP and Thermally Broken Vertical Brackets and Rail System Supporting Metal Cladding – Triple Glazed Vinyl Window and Intermediate Floor Intersection	
Detail 5.3.21	A.5.207
Exterior Insulated 6" x 1 5/8" Steel Stud (16" o.c.) Wall Assembly with FRP and Thermally Broken Vertical Brackets and Rail System Supporting Metal Cladding with Aerogel Insulation Blanket – Triple Glazed Vinyl Window and Intermediate Floor Intersection	
Detail 5.3.22	A.5.208
Exterior and Interior Insulated 6" x 1 5/8" Steel Stud (16" o.c.) Wall Assembly with FRP and Thermally Broken Vertical Brackets and Rail System Supporting Metal Cladding and R-19 Batt in Stud Cavity – Triple Glazed Vinyl Window and Intermediate Floor Intersection	
Detail 5.3.23	A.5.209
Exterior and Interior Insulated 6" x 1 5/8" Steel Stud (16" o.c.) Wall Assembly with FRP and Thermally Broken Vertical Brackets and Rail System Supporting Metal Cladding with Aerogel Insulation Blanket and R-19 Batt in Stud Cavity– Triple Glazed Vinyl Window and Intermediate Floor Intersection	
Detail 5.4.1	A.5.210
Exterior Insulated 3 5/8" x 1 5/8" Steel Stud (16" o.c.) Drained EIFS Wall Assembly – Conventional Curtain Wall Transition	
Detail 5.4.2	A.5.211
Exterior and Interior Insulated 3 5/8" x 1 5/8" Steel Stud (16" o.c.) Drained EIFS Wall Assembly with R-12 Batt Insulation in Stud Cavity – Conventional Curtain Wall Transition	
Detail 5.4.3	A.5.212
Exterior and Interior Insulated 3 5/8" x 1 5/8" Steel Stud (16" o.c.) Wall Assembly with R-12 Batt Insulation in Stud Cavity – Curtain Wall Transition	
Detail 5.4.4	A.5.213
Exterior and Interior Insulated 3 5/8" x 1 5/8" Steel Stud (16" o.c.) Wall Assembly with Horizontal Z-Girts (24" o.c.) Supporting Metal Cladding and R-12 Batt Insulation in Stud Cavity – Conventional Curtain Wall Intersection	
Detail 5.4.5	A.5.214
Exterior Insulated Concrete Wall and Steel Stud Assembly Supporting Metal Cladding – Curtain Wall Transition Intersection	
Detail 5.4.6	A.5.215

Exterior Insulated Concrete Wall and Steel Stud Assembly Supporting Metal Cladding with Cavity Insulation – Curtain Wall Transition Intersection	
Detail 5.5.1	A.5.216
Exterior Insulated 3 5/8" x 1 5/8" Steel Stud (16" o.c.) Drained EIFS Wall Assembly – Concrete Parapet & Slab Intersection	
Detail 5.5.2	A.5.217
Exterior Insulated 3 5/8" x 1 5/8" Steel Stud (16" o.c.) Drained EIFS Wall Assembly – Insulated Concrete Parapet & Slab Intersection	
Detail 5.5.3	A.5.218
Exterior and Interior Insulated 3 5/8" x 1 5/8" Steel Stud (16" o.c.) Drained EIFS Wall Assembly with R-12 Batt Insulation in Stud Cavity – Concrete Parapet & Slab Intersection	
Detail 5.5.4	A.5.219
Exterior and Interior Insulated 3 5/8" x 1 5/8" Steel Stud (16" o.c.) Drained EIFS Wall Assembly with R-12 Batt Insulation in Stud Cavity – Insulated Concrete Parapet & Slab Intersection	
Detail 5.5.5	A.5.220
Exterior Insulated 3 5/8" x 1 5/8" Steel Stud (16" o.c.) Wall Assembly with Horizontal Z-Girts (24" o.c.) Supporting Metal Cladding – Concrete Parapet & Slab Intersection	
Detail 5.5.6	A.5.221
Exterior and Interior Insulated 3 5/8" x 1 5/8" Steel Stud (16" o.c.) Wall Assembly with Horizontal Z-girts (24" o.c.) Supporting Metal Cladding and R-12 Batt Insulation in Stud Cavity – Concrete Parapet and Slab Intersection	
Detail 5.5.7	A.5.222
Exterior and Interior Insulated 3 5/8" x 1 5/8" Steel Stud (16" o.c.) Wall Assembly with Vertical Z Girts (16" o.c.) Supporting Stucco Cladding and R-12 Batt Insulation in Stud Cavity – Concrete Parapet & Slab Intersection	
Detail 5.5.8	A.5.223
Exterior and Interior Insulated 3 5/8" x 1 5/8" Steel Stud (16" o.c.) Wall Assembly with Intermittent Vertical Z Girts (16" o.c.) Supporting Metal Cladding and R-12 Batt Insulation in Stud Cavity – Concrete Roof Deck at Continuous Concrete Parapet	
Detail 5.5.9	A.5.224
Exterior and Interior Insulated 3 5/8" x 1 5/8" Steel Stud (16" o.c.) Wall Assembly with Intermittent Vertical Z Girts (16" o.c.) Supporting Metal Cladding and R-12 Batt Insulation in Stud Cavity – Concrete Roof Deck at Isokorb AXT1 Thermally Broken Concrete Parapet	
Detail 5.5.10	A.5.225
Exterior and Interior Insulated 3 5/8" x 1 5/8" Steel Stud (16" o.c.) Wall Assembly with Horizontal Z-Girts (24" o.c.) Supporting Metal Cladding and R-12 Batt	

Insulation in Stud Cavity – Steel Roof Deck with Open Web Steel Joist & Parapet Intersection

Detail 5.5.11A.5.226

Exterior and Interior Insulated 3 5/8" x 1 5/8" Steel Stud (16" o.c.) Wall Assembly with Horizontal Z-Girts (24" o.c.) Supporting Metal Cladding and R-12 Batt Insulation in Stud Cavity – Steel Roof Deck with Open Web Steel Joist & Parapet Intersection with Thermal Break under Parapet Stud Cavity

Detail 5.5.12A.5.227

Owens Corning Exterior Insulated 6" x 1 5/8" Steel Stud (16" o.c.) Wall Assembly with Thermally Isolated Vertical Brackets and Rail System (24" o.c.) Supporting Metal Cladding – Concrete Parapet and Roof Intersection

Detail 5.5.13A.5.228

Exterior and Interior Insulated 6" x 1 5/8" Steel Stud (16" o.c.) Wall Assembly with Thermally Isolated Vertical Brackets and Rail System (24" o.c.) Supporting Metal Cladding and Owens Corning R-20 Batt in Stud Cavity – Concrete Parapet and Roof Intersection

Detail 5.5.14A.5.229

Exterior and Interior Insulated 6" x 1 5/8" Steel Stud (16" o.c.) Wall Assembly with Thermally Isolated Vertical Brackets and Rail System (24" o.c.) Supporting Metal Cladding and Owens Corning R-22.5 Batt in Stud Cavity – Concrete Parapet and Roof Intersection

Detail 5.5.15A.5.230

Exterior and Interior Insulated 6" x 1 5/8" Steel Stud (16" o.c.) Wall Assembly with Thermally Isolated Vertical Brackets and Rail System (24" o.c.) Supporting Metal Cladding and Owens Corning R-24 Batt in Stud Cavity – Concrete Parapet and Roof Intersection

Detail 5.5.16A.5.231

Owens Corning Exterior Insulated 6" x 1 5/8" Steel Stud (16" o.c.) Wall Assembly with Thermally Isolated Vertical Brackets and Rail System (24" o.c.) Supporting Metal Cladding – Concrete Roof Deck at Isokorb AXTI Thermal Broken Concrete Parapet

Detail 5.5.17A.5.232

Exterior and Interior Insulated 6" x 1 5/8" Steel Stud (16" o.c.) Wall Assembly with Thermally Isolated Vertical Brackets and Rail System (24" o.c.) Supporting Metal Cladding and Owens Corning R-20 Batt in Stud Cavity – Concrete Roof Deck at Isokorb AXTI Thermal Broken Concrete Parapet

Detail 5.5.18A.5.233

Exterior and Interior Insulated 6" x 1 5/8" Steel Stud (16" o.c.) Wall Assembly with Thermally Isolated Vertical Brackets and Rail System (24" o.c.) Supporting Metal Cladding and Owens Corning R-22.5 Batt in Stud Cavity – Concrete Roof Deck at Isokorb AXTI Thermal Broken Concrete Parapet

Detail 5.5.19A.5.234

Exterior and Interior Insulated 6" x 1 5/8" Steel Stud (16" o.c.) Wall Assembly with Thermally Isolated Vertical Brackets and Rail System (24" o.c.) Supporting Metal Cladding and Owens Corning R-24 Batt in Stud Cavity – Concrete Roof Deck at Isokorb AXTI Thermal Broken Concrete Parapet	
Detail 5.5.20	A.5.235
Exterior Insulated 6" x 1 5/8" Steel Stud (16" o.c.) Wall Assembly with FRP and Thermally Broken Vertical Brackets and Rail System Supporting Metal Cladding – Concrete Roof Deck at Isokorb AXT Thermally Broken Concrete Parapet	
Detail 5.5.21	A.5.236
Exterior and Interior Insulated 6" x 1 5/8" Steel Stud (16" o.c.) Wall Assembly with FRP and Thermally Broken Vertical Brackets and Rail System Supporting Metal Cladding and R-19 Batt in Stud Cavity – Concrete Roof Deck at Isokorb AXT Thermally Broken Concrete Parapet	
Detail 5.5.22	A.5.237
Exterior Insulated 6" x 1 5/8" Steel Stud (16" o.c.) Wall Assembly with Thermally Isolated Vertical Brackets and Rail System (24" o.c.) Supporting Metal Cladding – Concrete Parapet and Roof Intersection	
Detail 5.5.23	A.5.238
Exterior and Interior Insulated 6" x 1 5/8" Steel Stud (16" o.c.) Wall Assembly with Thermally Isolated Vertical Brackets and Rail System (24" o.c.) Supporting Metal Cladding and R-20 Batt in Stud Cavity – Concrete Parapet and Roof Intersection	
Detail 5.5.24	A.5.239
Exterior Insulated 6" x 1 5/8" Steel Stud (16" o.c.) Wall Assembly with Thermally Isolated Vertical Brackets and Rail System (24" o.c.) Supporting Metal Cladding – Concrete Roof Deck at Isokorb AXTI Thermal Broken Concrete Parapet	
Detail 5.5.25	A.5.240
Exterior and Interior Insulated 6" x 1 5/8" Steel Stud (16" o.c.) Wall Assembly with Thermally Isolated Vertical Brackets and Rail System (24" o.c.) Supporting Metal Cladding and R-20 Batt in Stud Cavity – Concrete Roof Deck at Isokorb AXTI Thermal Broken Concrete Parapet	
Detail 5.6.1	A.5.241
Exterior Insulated 3 5/8" x 1 5/8" Steel Stud (16" o.c.) Drained EIFS Wall Assembly – Corner Intersection	
Detail 5.6.2	A.5.242
Exterior and Interior Insulated 3 5/8" x 1 5/8" Steel Stud (16" o.c.) Drained EIFS Wall Assembly with R-12 Batt Insulation in Stud Cavity – Corner Intersection	
Detail 5.6.3	A.5.243
Exterior Insulated 3 5/8" x 1 5/8" Steel Stud (16" o.c.) Wall Assembly with Horizontal Z-Girts (24" o.c.) Supporting Metal Cladding – Corner Intersection	
Detail 5.6.4	A.5.244

Exterior Insulated 3 5/8" x 1 5/8" Steel Stud (16" o.c.) Wall Assembly with Horizontal Z-Girts (24" o.c.) Supporting Metal Cladding – Corner Intersection with Alternative Framing

Detail 5.6.5**A.5.245**

Exterior and Interior Insulated 3 5/8" x 1 5/8" Steel Stud (16" o.c.) Wall Assembly with Horizontal Z-girts (24" o.c.) Supporting Metal Cladding and R-12 Batt Insulation in Stud Cavity – Corner Intersection

Detail 5.6.6**A.5.246**

Window Wall System – Transition to Exterior Insulated Steel Stud Wall Assembly with Horizontal Z-girts (24" o.c.) Supporting Metal Cladding & No Interior Stud Cavity Insulation

Detail 5.6.7**A.5.247**

Window Wall System – Transition to Exterior Insulated Steel Stud Wall Assembly with Horizontal Z-girts (24" o.c.) Supporting Metal Cladding & Interior Sprayfoam and Fibreglass Batt Insulation

Detail 5.7.1**A.5.248**

Exterior and Interior Insulated 3 5/8" x 1 5/8" Steel Stud (16" o.c.) Wall Assembly with Horizontal Z-Girts (24" o.c.) Supporting Metal Cladding and R-12 Batt Insulation in Stud Cavity – Structural Steel Column & Cantilever Beam Intersection (Canopy Support)

Detail 5.7.2**A.5.249**

Exterior and Interior Insulated 3 5/8" x 1 5/8" Steel Stud (16" o.c.) Wall Assembly with Horizontal Z-girts (24" o.c.) Supporting Metal Cladding and R-12 Batt Insulation in Stud Cavity – Structural Steel Floor Intersection with Uninterrupted Beam

Detail 5.7.3**A.5.250**

Exterior and Interior Insulated 3 5/8" x 1 5/8" Steel Stud (16" o.c.) Wall Assembly with Horizontal Z-girts (24" o.c.) Supporting Metal Cladding and R-12 Batt Insulation in Stud Cavity – Structural Steel Floor Intersection with Isolator Pad

Detail 5.7.4**A.5.251**

Exterior and Interior Insulated 3 5/8" x 1 5/8" Steel Stud (16" o.c.) Wall Assembly with Horizontal Z-girts (24" o.c.) Supporting Metal Cladding and R-12 Batt Insulation in Stud Cavity – Structural Steel Floor Intersection with Isokorb S22 Thermally Broken Beam

Detail 5.7.5**A.5.252**

Exterior Insulated 3 5/8" x 1 5/8" Steel Stud (16" o.c.) Wall Assembly with Intermittent Vertical Z-girts (16" o.c.) Supporting Metal Cladding – Concrete Floor to Steel Beam Connection

Detail 5.7.6**A.5.253**

Exterior Insulated 3 5/8" x 1 5/8" Steel Stud (16" o.c.) Wall Assembly with Intermittent Vertical Z-girts (16" o.c.) Supporting Metal Cladding – Concrete Floor to Steel Beam with a Thermal Isolator Pad Connection

Detail 5.7.7	A.5.254
Exterior Insulated 3 5/8" x 1 5/8" Steel Stud (16" o.c.) Wall Assembly with Intermittent Vertical Z-girts (16" o.c.) Supporting Metal Cladding – Concrete Floor to Steel Beam with Isokorb KS14 Connection	
Detail 5.7.8	A.5.255
Exterior and Interior Insulated 3 5/8" x 1 5/8" Steel Stud (16" o.c.) Wall Assembly with Horizontal Z-girts (24" o.c.) Supporting Metal Cladding and R-12 Batt Insulation in Stud Cavity – Structural Steel Floor Intersection with Beam Thermal Break	
Detail 5.7.9	A.5.256
Exterior and Interior Insulated 3 5/8" x 1 5/8" Steel Stud (16" o.c.) Wall Assembly with Horizontal Z-girts (24" o.c.) Supporting Metal Cladding and R-12 Batt Insulation in Stud Cavity – Structural Steel Floor Intersection with Aerolon Coating	
Detail 5.7.10	A.5.257
Exterior Insulated 6" x 1 5/8" Steel Stud (16" o.c.) Wall Assembly with FRP Vertical Brackets and Rail System Supporting Metal Cladding – Structural Steel Column & Knife Edge Cable Support Intersection	
Detail 5.7.11	A.5.258
Exterior and Interior Insulated 6" x 1 5/8" Steel Stud (16" o.c.) Wall Assembly with FRP Vertical Brackets and Rail System Supporting Metal Cladding with R-19 Batt in Stud Cavity – Structural Steel Column & Knife Edge Cable Support Intersection	
Detail 5.7.12	A.5.259
Exterior and Interior Insulated 3 5/8" x 1 5/8" Steel Stud (16" o.c.) Wall Assembly with Horizontal Z-girts (24" o.c.) Supporting Metal Cladding and R-12 Batt Insulation in Stud Cavity – Structural Steel Floor Intersection with Thermal Isolator Pad	
Detail 5.7.13	A.5.260
Exterior and Interior Insulated 3 5/8" x 1 5/8" Steel Stud (16" o.c.) Wall Assembly with Horizontal Z-girts (24" o.c.) Supporting Metal Cladding and R-12 Batt Insulation in Stud Cavity – Structural Steel Floor Intersection with Isokorb KST System Thermally Broken Beam	
Detail 5.8.1	A.5.261
Exterior and Interior Insulated 3 5/8" x 1 5/8" Steel Stud (16" o.c.) Wall Assembly with Horizontal Z-Girts (24" o.c.) Supporting Metal Cladding and R-12 Batt Insulation in Stud Cavity – Interior Wall Intersection	
Detail 5.8.2	A.5.262
Exterior Insulated 6" x 1 5/8" Steel Stud (16" o.c.) Wall Assembly with FRP Vertical Brackets and Rail System Supporting Metal Cladding – At-Grade Foundation Wall Intersection	
Detail 5.8.3	A.5.263

**Exterior and Interior Insulated 6" x 1 5/8" Steel Stud (16" o.c.) Wall Assembly
with FRP Vertical Brackets and Rail System Supporting Metal Cladding and R19
Batt Insulation in Stud Cavity – At-Grade Foundation Wall Intersection**

Detail 5.1.1

Interior Insulated 3 5/8" x 1 5/8" Steel Stud Wall Assembly – Clear Wall

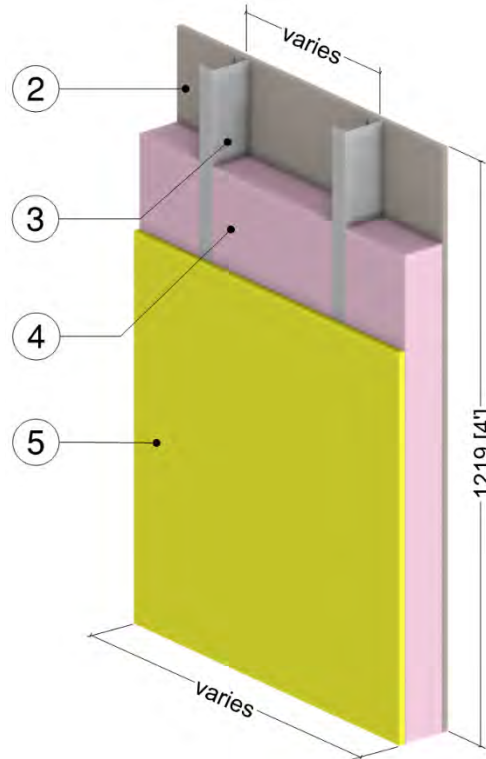

ID	Component	Thickness Inches (mm)	Conductivity Btu-in / ft ² -hr-°F (W/m K)	Nominal Resistance hr-ft ² -°F/Btu (m ² K/W)	Density lb/ft ³ (kg/m ³)	Specific Heat Btu/lb-°F (J/kg K)
1	Interior Film ¹	-	-	R-0.7 (0.12 RSI)	-	-
2	Gypsum Board	1/2" (13)	1.1 (0.16)	R-0.5 (0.08 RSI)	50 (800)	0.26 (1090)
3	3 5/8" x 1 5/8" Steel Studs	18 Gauge	430 (62)	-	489 (7830)	0.12 (500)
4	Air or Fiberglass Batt Insulation in Stud Cavity	3 5/8" (92)	-	R-0.9 to R-13 (0.16 to 2.29 RSI)	varies	varies
5	Exterior Sheathing	1/2" (13)	1.1 (0.16)	R-0.5 (0.08 RSI)	50 (800)	0.26 (1090)
6	Metal cladding with 1/2" (13 mm) vented air space is incorporated into exterior heat transfer coefficient					
7	Exterior Film ¹	-	-	R-0.7 (0.012 RSI)	-	-

¹ Value selected from table 1, p. 26.1 of 2009 ASHRAE Handbook – Fundamentals depending on surface orientation

Detail 5.1.2

Interior Insulated 6" x 1 5/8" Steel Stud Wall Assembly – Clear Wall

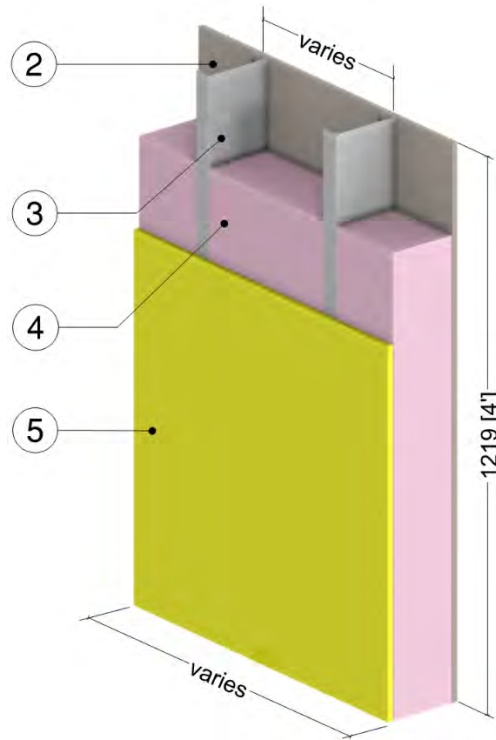

ID	Component	Thickness Inches (mm)	Conductivity Btu-in / ft ² ·hr·°F (W/m K)	Nominal Resistance hr·ft ² ·°F/Btu (m ² K/W)	Density lb/ft ³ (kg/m ³)	Specific Heat Btu/lb·°F (J/kg K)
1	Interior Film ¹	-	-	R-0.7 (0.12 RSI)	-	-
2	Gypsum Board	1/2" (13)	1.1 (0.16)	R-0.5 (0.08 RSI)	50 (800)	0.26 (1090)
3	6" x 1 5/8" Steel Studs	18 Gauge	430 (62)	-	489 (7830)	0.12 (500)
4	Air or Fiberglass Batt Insulation in Stud Cavity	6" (152)	-	R-0.9 to R-24 (0.16 to 4.23 RSI)	varies	varies
5	Exterior Sheathing	1/2" (13)	1.1 (0.16)	R-0.5 (0.08 RSI)	50 (800)	0.26 (1090)
6	Metal cladding with 1/2" (13 mm) vented air space is incorporated into exterior heat transfer coefficient					
7	Exterior Film ¹	-	-	R-0.7 (0.012 RSI)	-	-

¹ Value selected from table 1, p. 26.1 of 2009 ASHRAE Handbook – Fundamentals depending on surface orientation

Detail 5.1.3

Exterior Insulated 3 5/8" x 1 5/8" Steel Stud (16" o.c.) Drained EIFS Wall Assembly – Clear Wall

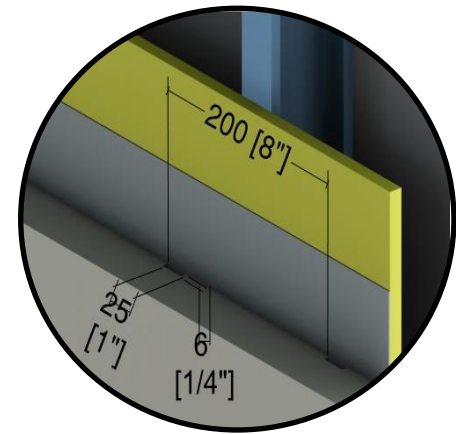
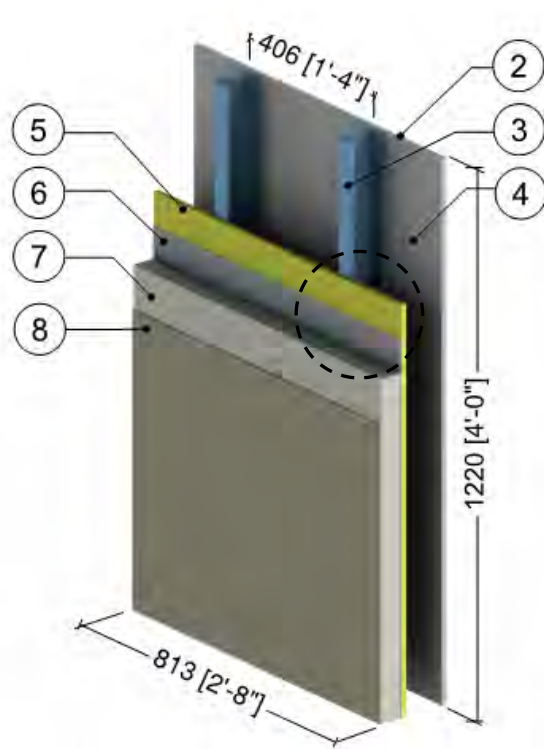

1" (25 mm)
Drained EIFS
Detail

ID	Component	Thickness Inches (mm)	Conductivity Btu-in / ft ² -hr-°F (W/m K)	Nominal Resistance hr-ft ² -°F/Btu (m ² K/W)	Density lb/ft ³ (kg/m ³)	Specific Heat Btu/lb-°F (J/kg K)
1	Interior Films ¹	-	-	R-0.7 (0.12 RSI)	-	-
2	Gypsum Board	1/2" (13)	1.1 (0.16)	R-0.5 (0.08 RSI)	50 (800)	0.26 (1090)
3	3 5/8" x 1 5/8" Steel Studs (16"o.c.)	18 Gauge	430 (62)	-	489 (7830)	0.12 (500)
4	Air in Stud Cavity	3 5/8" (92)	-	R-0.9 (0.16 RSI)	0.075 (1.2)	0.24 (1000)
5	Exterior Sheathing	1/2" (13)	1.1 (0.16)	R-0.5 (0.08 RSI)	50 (800)	0.26 (1090)
6	Weather Resistive Barrier with Adhesive	-	-	-	-	-
7	Insulation Board	2" to 4" (50 to 100)	0.27 (0.039)	R-7.5 to R-15 (1.32 to 2.64 RSI)	1 (16)	0.35 (1470)
8	Lamina	1/8" (4)	6 (0.9)	R-0.04 (0.01 RSI)	120 (1922)	0.20 (850)
9	Exterior Film ¹	-	-	R-0.2 (0.03 RSI)	-	-

¹ Value selected from table 1, p. 26.1 of 2009 ASHRAE Handbook – Fundamentals depending on surface orientation

Detail 5.1.4

Exterior and Interior Insulated 3 5/8" x 1 5/8" Steel Stud (16" o.c.) Drained EIFS Wall Assembly with R-12 Batt Insulation in Stud Cavity – Clear Wall

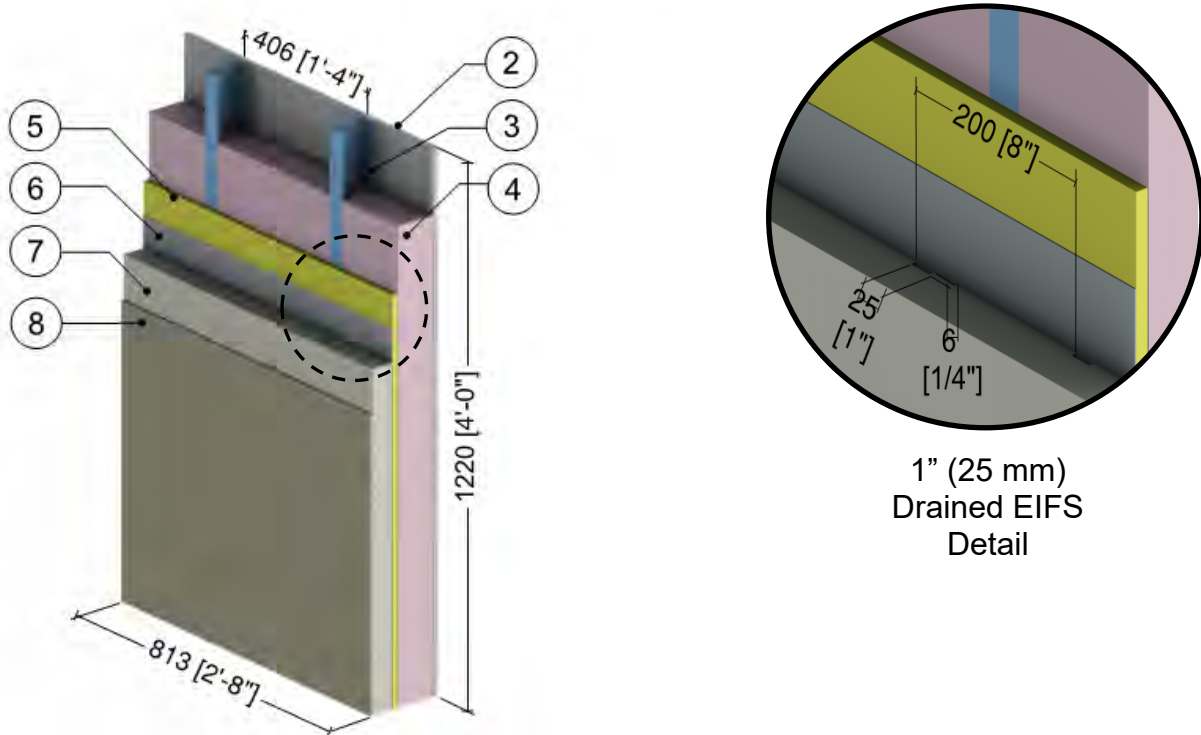

ID	Component	Thickness Inches (mm)	Conductivity Btu·in / ft ² ·hr·°F (W/m K)	Nominal Resistance hr·ft ² ·°F/Btu (m ² K/W)	Density lb/ft ³ (kg/m ³)	Specific Heat Btu/lb·°F (J/kg K)
1	Interior Films ¹	-	-	R-0.7 (0.12 RSI)	-	-
2	Gypsum Board	1/2" (13)	1.1 (0.16)	R-0.5 (0.08 RSI)	50 (800)	0.26 (1090)
3	3 5/8" x 1 5/8" Steel Studs (16"o.c.)	18 Gauge	430 (62)	-	489 (7830)	0.12 (500)
4	Fiberglass Batt Insulation	3 5/8" (92)	0.31 (0.044)	R-12 (2.1 RSI)	0.9 (14)	0.17 (710)
5	Exterior Sheathing	1/2" (13)	1.1 (0.16)	R-0.5 (0.08 RSI)	50 (800)	0.26 (1090)
6	Weather Resistive Barrier with Adhesive	-	-	-	-	-
7	Insulation Board	2" to 6" (50 to 152)	0.27 (0.038)	R-7.5 to R-22.5 (1.32 to 3.96 RSI)	1 (16)	0.35 (1470)
8	Lamina	1/8" (4)	6 (0.9)	R-0.04 (0.01 RSI)	120 (1922)	0.20 (850)
9	Exterior Film ¹	-	-	R-0.2 (0.03 RSI)	-	-

¹ Value selected from table 1, p. 26.1 of 2009 ASHRAE Handbook – Fundamentals depending on surface orientation

Detail 5.1.5

Exterior Insulated 3 5/8" x 1 5/8" Steel Stud (16" o.c.) Wall Assembly with Vertical Z-Girts (16" o.c.) Supporting Metal Cladding – Clear Wall

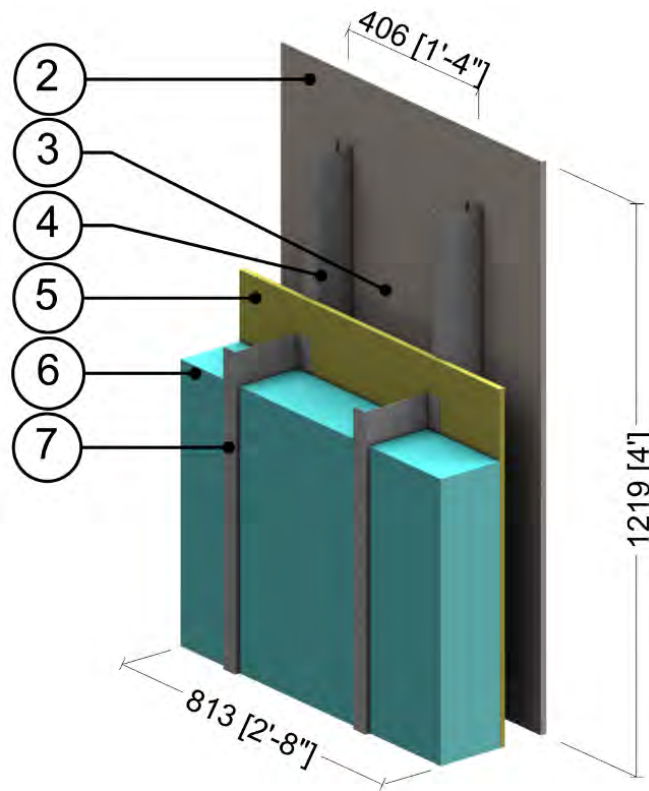

ID	Component	Thickness Inches (mm)	Conductivity Btu-in / ft ² -hr-°F (W/m K)	Nominal Resistance hr-ft ² -°F/Btu (m ² K/W)	Density lb/ft ³ (kg/m ³)	Specific Heat Btu/lb-°F (J/kg K)
1	Interior Film ¹	-	-	R-0.7 (0.12 RSI)	-	-
2	Gypsum Board	1/2" (13)	1.1 (0.16)	R-0.5 (0.08 RSI)	50 (800)	0.26 (1090)
3	Air in Stud Cavity	3 5/8" (92)	-	R-0.9 (0.16 RSI)	0.075 (1.2)	0.24 (1000)
4	3 5/8" x 1 5/8" Steel Studs	18 gauge	430 (62)	-	489 (7830)	0.12 (500)
5	Exterior Sheathing	1/2" (13)	1.1 (0.16)	R-0.5 (0.08 RSI)	50 (800)	0.26 (1090)
6	Exterior Insulation	Varies	-	R-5 to R-40 (0.88 to 7.0 RSI)	1.8 (28)	0.29 (1220)
7	Vertical Z-Girts w/ 1 1/2" Flange	18 gauge	430 (62)	-	489 (7830)	0.12 (500)
8	Metal cladding with 1/2" (13mm) vented air space is incorporated into exterior heat transfer coefficient					
9	Exterior Film ¹	-	-	R-0.7 (0.12 RSI)	-	-

¹ Value selected from table 1, p. 26.1 of 2009 ASHRAE Handbook – Fundamentals depending on surface orientation

Detail 5.1.6

Exterior and Interior Insulated 6" x 1 5/8" Steel Stud (16" o.c.) Wall Assembly with Vertical Z-Girts (16" o.c.) Supporting Metal Cladding and R-20 Batt Insulation in Stud Cavity – Clear Wall

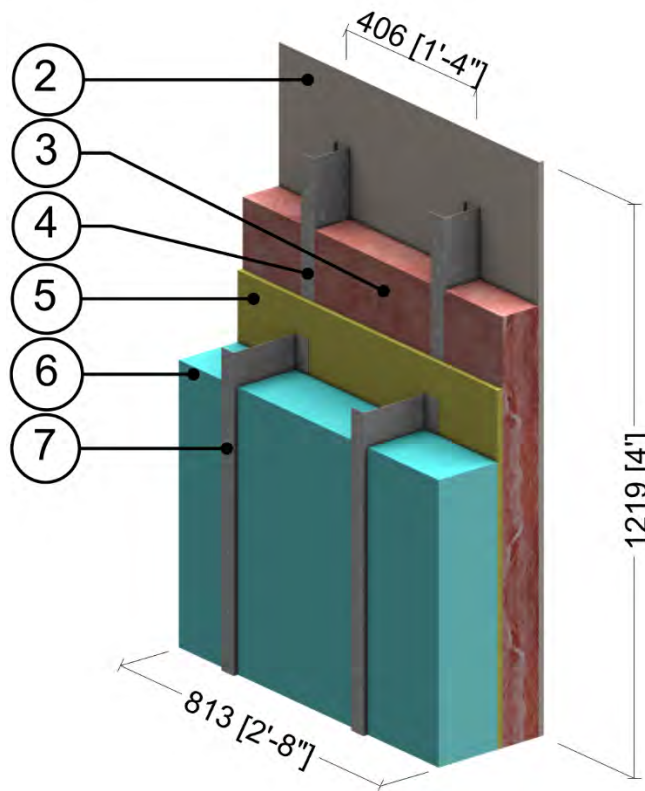

ID	Component	Thickness Inches (mm)	Conductivity Btu-in / ft ² -hr-°F (W/m K)	Nominal Resistance hr-ft ² -°F/Btu (m ² K/W)	Density lb/ft ³ (kg/m ³)	Specific Heat Btu/lb-°F (J/kg K)
1	Interior Film ¹	-	-	R-0.7 (0.12 RSI)	-	-
2	Gypsum Board	1/2" (13)	1.1 (0.16)	R-0.5 (0.08 RSI)	50 (800)	0.26 (1090)
3	Fiberglass Batt Insulation	6" (152)	0.30 (0.043)	R-20 (3.52 RSI)	0.9 (14)	0.17 (710)
4	6" x 1 5/8" Steel Studs	18 gauge	430 (62)	-	489 (7830)	0.12 (500)
5	Exterior Sheathing	1/2" (13)	1.1 (0.16)	R-0.5 (0.08 RSI)	50 (800)	0.26 (1090)
6	Exterior Insulation	Varies	0.20 (0.029)	R-20 to R-30 (3.52 to 5.28 RSI)	1.8 (28)	0.29 (1220)
7	Vertical Z-Girts w/ 1 1/2" Flange	18 gauge	430 (62)	-	489 (7830)	0.12 (500)
8	Metal cladding with 1/2" (13mm) vented air space is incorporated into exterior heat transfer coefficient					
9	Exterior Film ¹	-	-	R-0.7 (0.12 RSI)	-	-

¹ Value selected from table 1, p. 26.1 of 2009 ASHRAE Handbook – Fundamentals depending on surface orientation

Detail 5.1.7

Exterior and Interior Insulated 6" x 1 5/8" Steel Stud (16" o.c.) Wall Assembly with Vertical Z-Girts (16" o.c.) and 1 1/2" Spray Foam (R-9.8) in Stud Cavity – Clear Wall

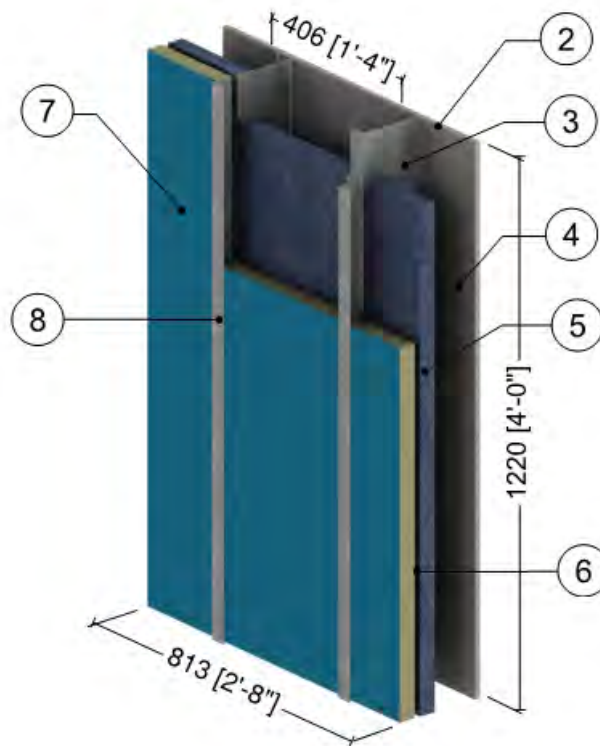

ID	Component	Thickness Inches (mm)	Conductivity Btu-in / ft ² ·hr·°F (W/m K)	Nominal Resistance hr·ft ² ·°F/Btu (m ² K/W)	Density lb/ft ³ (kg/m ³)	Specific Heat Btu/lb·°F (J/kg K)
1	Interior Films ¹	-	-	R-0.7 (0.12 RSI)	-	-
2	Gypsum Board	5/8" (16)	0.09 (0.16)	R-0.5 (0.08 RSI)	50 (800)	0.26 (1090)
3	6" x 1 5/8" Steel Studs (16" o.c.)	18 Gauge	250 (36)	-	489 (7830)	0.12 (500)
4	Air in Stud Cavity	4 1/2" (114)	-	R-0.9 (0.16 RSI)	0.075 (1.2)	0.24 (1000)
5	Spray Foam Insulation	1 1/2" (38)	-	R-9.8 (1.73 RSI)	-	-
6	Exterior Sheathing	5/8" (16)	0.09 (0.16)	R-0.5 (0.08 RSI)	50 (800)	0.26 (1090)
7	Exterior Polyisocyanurate Insulation	1 1/2" (38)	-	R-10.1 (1.78 RSI)	-	-
8	Vertical Z-Girts (16" o.c.)	18 Gauge	250 (36)	-	489 (7830)	0.12 (500)
9	Metal Cladding with vented airspace incorporated into exterior heat transfer coefficient					
10	Exterior Film ¹	-	-	R-0.7 (0.12 RSI)	-	-

¹ Value selected from table 1, p. 26.1 of 2009 ASHRAE Handbook – Fundamentals depending on surface orientation

Detail 5.1.8

Exterior and Interior Insulated 6" x 1 5/8" Steel Stud (16" o.c.) Wall Assembly with Vertical Z-Girts (16" o.c.) and 2" Spray Foam (R-11.4) in Stud Cavity – Clear Wall

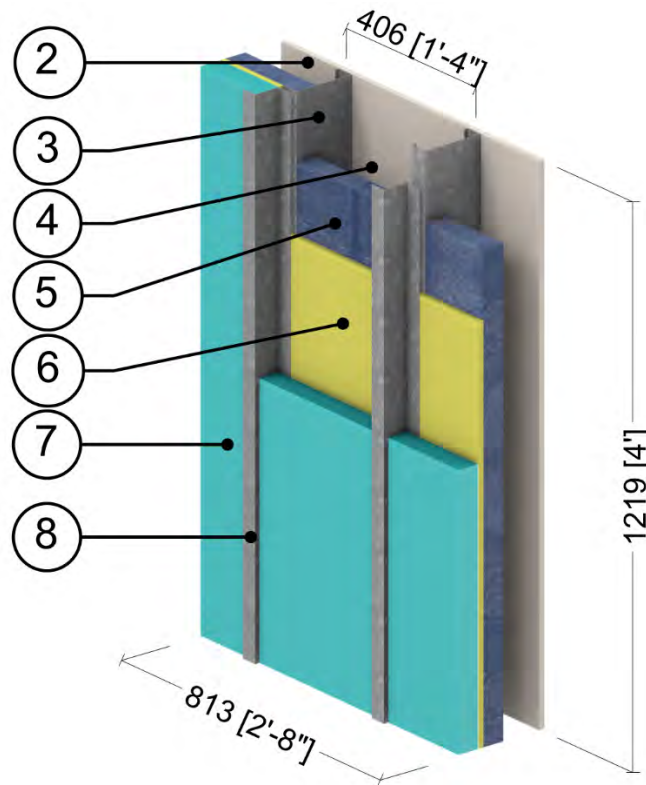

ID	Component	Thickness Inches (mm)	Conductivity Btu·in / ft ² ·hr·°F (W/m K)	Nominal Resistance hr·ft ² ·°F/Btu (m ² K/W)	Density lb/ft ³ (kg/m ³)	Specific Heat Btu/lb·°F (J/kg K)
1	Interior Films ¹	-	-	R-0.7 (0.12 RSI)	-	-
2	Gypsum Board	1/2" (13)	1.1 (0.16)	R-0.5 (0.08 RSI)	50 (800)	0.26 (1090)
3	6" x 1 5/8" Steel Studs (16" o.c.)	18 gauge	430 (62)	-	489 (7830)	0.12 (500)
4	Air in Stud Cavity	4" (102)	-	R-0.9 (0.16 RSI)	0.075 (1.2)	0.24 (1000)
5	Spray Foam Insulation	2" (51)	0.17 (0.025)	R-11.4 (2.01 RSI)	2.8 (39)	0.35 (1470)
6	Exterior Sheathing	1/2" (13)	1.1 (0.16)	R-0.5 (0.08 RSI)	50 (800)	0.26 (1090)
7	Exterior Insulation	Varies	0.20 (0.029)	R-10 to R-30 (1.76 to 5.28 RSI)	1.8 (28)	0.29 (1220)
8	Vertical Z-Girts (16" o.c.)	18 gauge	430 (62)	-	489 (7830)	0.12 (500)
9	Metal Cladding with vented airspace incorporated into exterior heat transfer coefficient					
10	Exterior Film ¹	-	-	R-0.7 (0.12 RSI)	-	-

¹ Value selected from table 1, p. 26.1 of 2009 ASHRAE Handbook – Fundamentals depending on surface orientation

Detail 5.1.9

Exterior Insulated 3 5/8" x 1 5/8" Steel Stud (16" o.c.) Wall Assembly with Horizontal Z-Girts (24" o.c.) Supporting Metal Cladding – Clear Wall

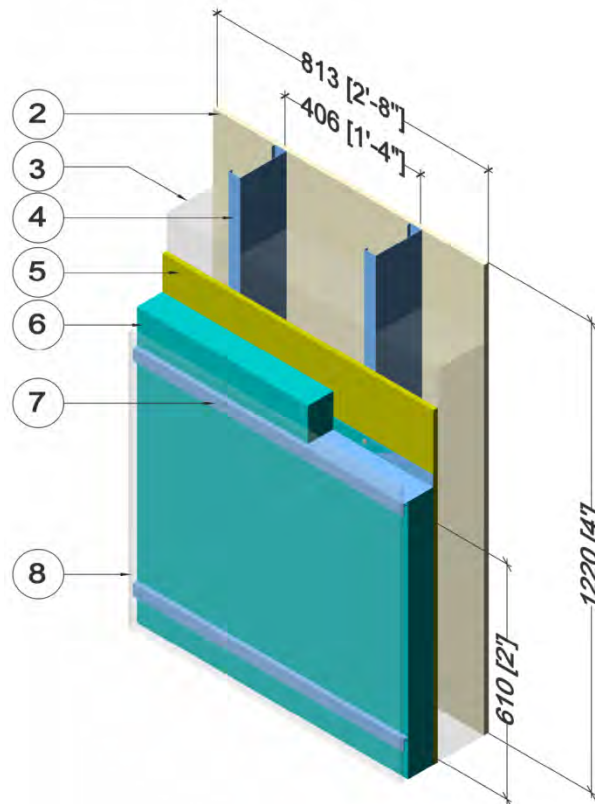

ID	Component	Thickness Inches (mm)	Conductivity Btu-in / ft ² ·hr·°F (W/m K)	Nominal Resistance hr·ft ² ·°F/Btu (m ² K/W)	Density lb/ft ³ (kg/m ³)	Specific Heat Btu/lb·°F (J/kg K)
1	Interior Film ¹	-	-	R-0.7 (0.12 RSI)	-	-
2	Gypsum Board	1/2" (13)	1.1 (0.16)	R-0.5 (0.08 RSI)	50 (800)	0.26 (1090)
3	Air in Stud Cavity	3 5/8" (92)	-	R-0.9 (0.16 RSI)	0.075 (1.2)	0.24 (1000)
4	3 5/8" x 1 5/8" Steel Studs	18 gauge	430 (62)	-	489 (7830)	0.12 (500)
5	Exterior Sheathing	1/2" (13)	1.1 (0.16)	R-0.5 (0.08 RSI)	50 (800)	0.26 (1090)
6	Exterior Insulation	Varies	-	R-5 to R-25 (0.88 to 4.4 RSI)	1.8 (28)	0.29 (1220)
7	Horizontal Z-Girts w/ 1 1/2" Flange	18 gauge	430 (62)	-	489 (7830)	0.12 (500)
8	Metal cladding with 1/2" (13mm) vented air space is incorporated into exterior heat transfer coefficient					
9	Exterior Film ¹	-	-	R-0.7 (0.12 RSI)	-	-

¹ Value selected from table 1, p. 26.1 of 2009 ASHRAE Handbook – Fundamentals depending on surface orientation

Detail 5.1.10

Exterior and Interior Insulated 6" x 1 5/8" Steel Stud (16" o.c.) Wall Assembly with Horizontal Z-Girts (24" o.c.) Supporting Cladding, Owens Corning ThermaFiber RainBarrier HC Max Insulation and R-20 Batt Insulation in Stud Cavity – Clear Wall

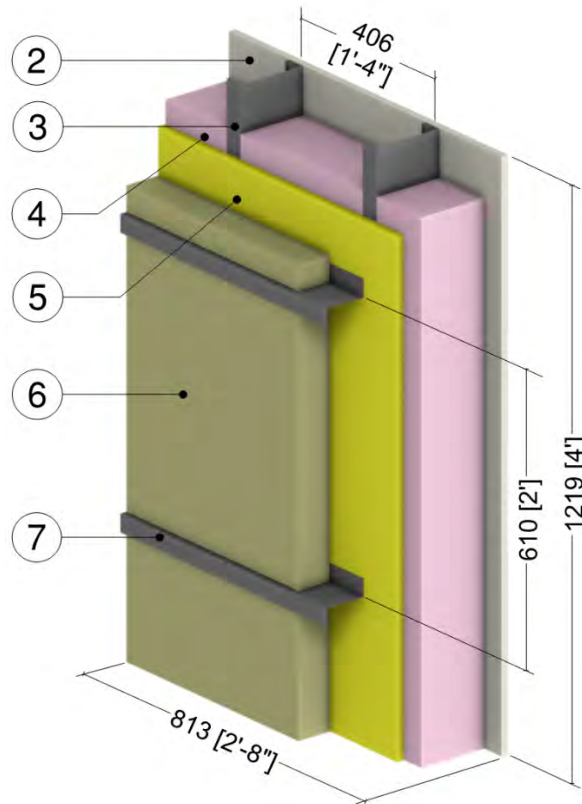

ID	Component	Thickness Inches (mm)	Conductivity Btu-in / ft ² ·hr·°F (W/m K)	Nominal Resistance hr·ft ² ·°F/Btu (m ² K/W)	Density lb/ft ³ (kg/m ³)	Specific Heat Btu/lb·°F (J/kg K)
1	Interior Film ¹	-	-	R-0.7 (0.12 RSI)	-	-
2	Gypsum Board	5/8" (16)	1.1 (0.16)	R-0.6 (0.10 RSI)	50 (800)	0.26 (1090)
3	6" x 1 5/8" Steel Studs	18 Gauge	430 (62)	-	489 (7830)	0.12 (500)
4	Ecotouch Pink Fiberglass Batt	6" (152)	0.30 (0.043)	R-20 (3.52 RSI)	0.55 (8.8)	0.17 (710)
5	Exterior Sheathing	5/8" (16)	1.1 (0.16)	R-0.6 (0.10 RSI)	50 (800)	0.26 (1090)
6	ThermaFiber RainBarrier HC Max Mineral Wool Semi Rigid Insulation	Varies	0.25 (0.036)	R-4 to R-24 (0.70 to 4.23 RSI)	11 (176)	0.20 (850)
7	Horizontal Z-Girts with 1-1/2" Flange	18 gauge	430 (62)	-	489 (7830)	0.12 (500)
8	Metal Cladding with 1/2" (13 mm) vented airspace incorporated into exterior heat transfer coefficient					
9	Exterior Film ¹	-	-	R-0.7 (0.12 RSI)	-	-

¹ Value selected from table 1, p. 26.1 of 2009 ASHRAE Handbook – Fundamentals depending on surface orientation

Detail 5.1.11

Exterior and Interior Insulated 6" x 1 5/8" Steel Stud (16" o.c.) Wall Assembly with Horizontal Z-Girts (24" o.c.) Supporting Cladding, Owens Corning ThermaFiber RainBarrier HC Plus 110 Insulation and R-20 Batt Insulation in Stud Cavity – Clear Wall

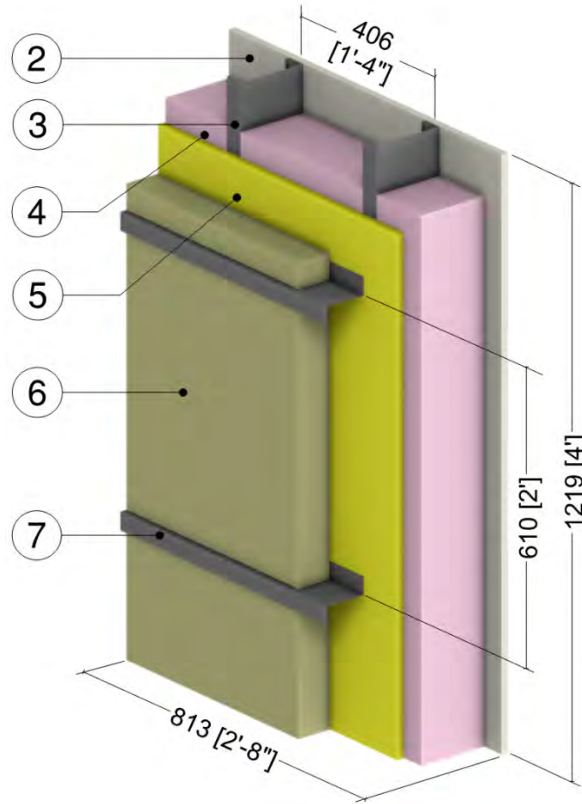

ID	Component	Thickness Inches (mm)	Conductivity Btu·in / ft ² ·hr·°F (W/m K)	Nominal Resistance hr·ft ² ·°F/Btu (m ² K/W)	Density lb/ft ³ (kg/m ³)	Specific Heat Btu/lb·°F (J/kg K)
1	Interior Film ¹	-	-	R-0.7 (0.12 RSI)	-	-
2	Gypsum Board	5/8" (16)	1.1 (0.16)	R-0.6 (0.10 RSI)	50 (800)	0.26 (1090)
3	6" x 1 5/8" Steel Studs	18 Gauge	430 (62)	-	489 (7830)	0.12 (500)
4	Ecotouch Pink Fiberglass Batt	6" (152)	0.30 (0.043)	R-20 (3.52 RSI)	0.55 (8.8)	0.17 (710)
5	Exterior Sheathing	5/8" (16)	1.1 (0.16)	R-0.6 (0.10 RSI)	50 (800)	0.26 (1090)
6	ThermaFiber RainBarrier HC Plus 110 Mineral Wool Semi Rigid Insulation	Varies	0.24 (0.035)	R-4.1 to R-24.6 (0.72 to 4.33 RSI)	8 (128)	0.20 (850)
7	Horizontal Z-Girts with 1-1/2" Flange	18 gauge	430 (62)	-	489 (7830)	0.12 (500)
8	Metal Cladding with 1/2" (13 mm) vented airspace incorporated into exterior heat transfer coefficient					
9	Exterior Film ¹	-	-	R-0.7 (0.12 RSI)	-	-

¹ Value selected from table 1, p. 26.1 of 2009 ASHRAE Handbook – Fundamentals depending on surface orientation

Detail 5.1.12

Exterior and Interior Insulated 6" x 1 5/8" Steel Stud (16" o.c.) Wall Assembly with Horizontal Z-Girts (24" o.c.) Supporting Cladding, Owens Corning ThermaFiber RainBarrier 45 Insulation and R-20 Batt Insulation in Stud Cavity – Clear Wall

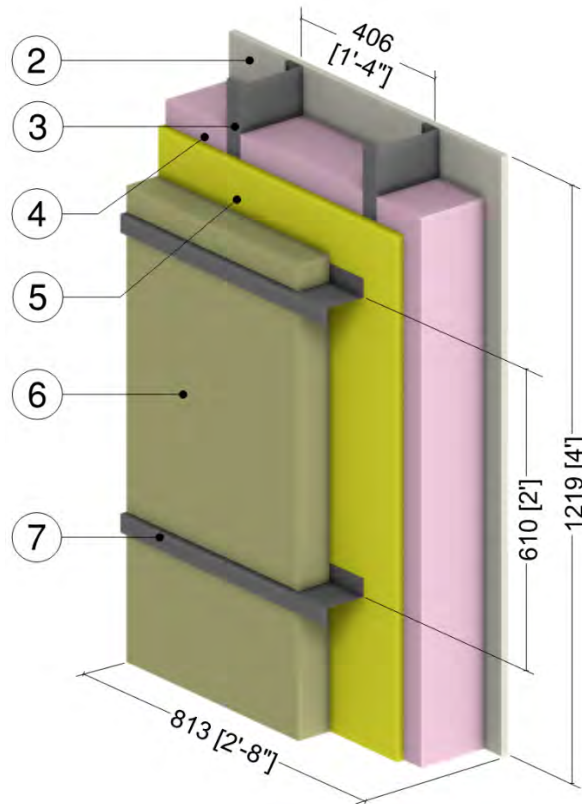

ID	Component	Thickness Inches (mm)	Conductivity Btu-in / ft ² ·hr·°F (W/m K)	Nominal Resistance hr·ft ² ·°F/Btu (m ² K/W)	Density lb/ft ³ (kg/m ³)	Specific Heat Btu/lb·°F (J/kg K)
1	Interior Film ¹	-	-	R-0.7 (0.12 RSI)	-	-
2	Gypsum Board	5/8" (16)	1.1 (0.16)	R-0.6 (0.10 RSI)	50 (800)	0.26 (1090)
3	6" x 1 5/8" Steel Studs	18 Gauge	430 (62)	-	489 (7830)	0.12 (500)
4	Ecotouch Pink Fiberglass Batt	6" (152)	0.30 (0.043)	R-20 (3.52 RSI)	0.55 (8.8)	0.17 (710)
5	Exterior Sheathing	5/8" (16)	1.1 (0.16)	R-0.6 (0.10 RSI)	50 (800)	0.26 (1090)
6	ThermaFiber RainBarrier 45 Mineral Wool Semi Rigid Insulation	Varies	0.24 (0.034)	R-4.2 to R-25.2 (0.74 to 4.44 RSI)	4.5 (72)	0.20 (850)
7	Horizontal Z-Girts with 1-1/2" Flange	18 gauge	430 (62)	-	489 (7830)	0.12 (500)
8	Metal Cladding with 1/2" (13 mm) vented airspace incorporated into exterior heat transfer coefficient					
9	Exterior Film ¹	-	-	R-0.7 (0.12 RSI)	-	-

¹ Value selected from table 1, p. 26.1 of 2009 ASHRAE Handbook – Fundamentals depending on surface orientation

Detail 5.1.13

Exterior and Interior Insulated 3 5/8" x 1 5/8" Steel Stud (16" o.c.) Wall Assembly with Vertical Z-girts (16" o.c.) Supporting Stucco Cladding and R-12 Batt Insulation in Stud Cavity – Clear Wall

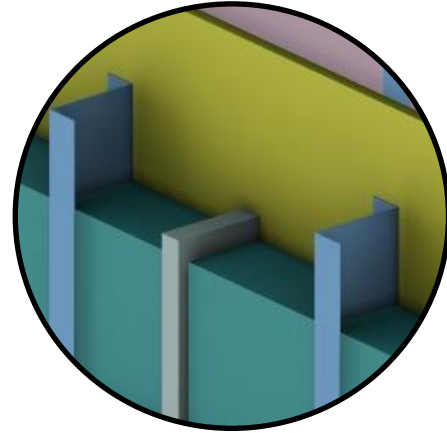
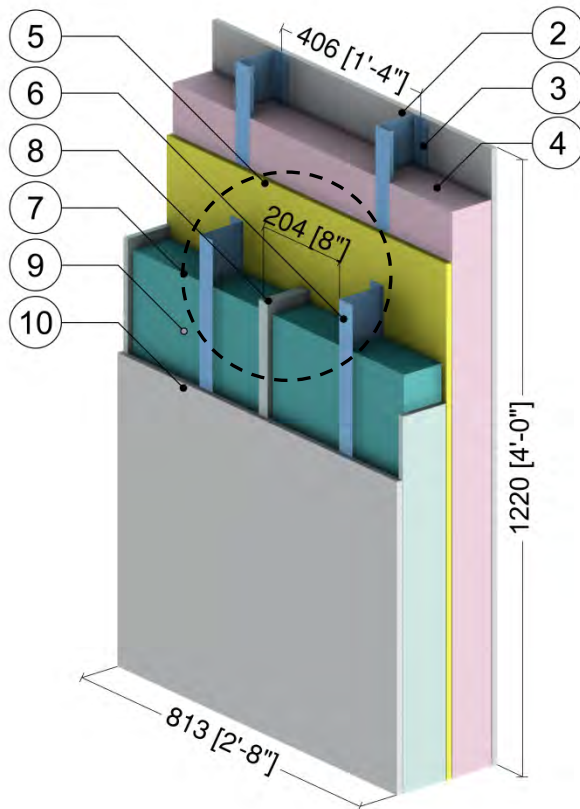

Bracing Detail

ID	Component	Thickness Inches (mm)	Conductivity Btu-in / ft ² ·hr·°F (W/m K)	Nominal Resistance hr·ft ² ·°F/Btu (m ² K/W)	Density lb/ft ³ (kg/m ³)	Specific Heat Btu/lb·°F (J/kg K)
1	Interior Film ¹	-	-	R-0.7 (0.12 RSI)	-	-
2	Gypsum Board	1/2" (13)	1.1 (0.16)	R-0.5 (0.08 RSI)	50 (800)	0.26 (1090)
3	3 5/8" x 1 5/8" Steel Studs	18 Gauge	430 (62)	-	489 (7830)	0.12 (500)
4	Fiberglass Batt Insulation	3 5/8" (92)	0.31 (0.044)	R-12 (2.1 RSI)	0.9 (14)	0.17 (710)
5	Exterior Sheathing	1/2" (13)	1.1 (0.16)	R-0.5 (0.08 RSI)	50 (800)	0.26 (1090)
6	Vertical Z-Girts with 1 1/2" Flange	18 Gauge	430 (62)	-	489 (7830)	0.12 (500)
7	Exterior Insulation	Varies	-	R-10 to R-20 (1.76 to 3.52 RSI)	1.8 (28)	0.29 (1220)
8	Rigid Insulation Bracing	Varies	0.2 (0.029)	-	1.8 (28)	0.29 (1220)
9	Rainscreen Cavity	1/2" (13)	-	R-0.5 (0.09 RSI)	0.075 (1.2)	0.24 (1000)
10	Stucco Cement with Breather Board	1/2" (13)	6 (0.9)	R-0.1 (0.01 RSI)	120 (1922)	0.20 (850)
11	Exterior Film ¹	-	-	R-0.2 (0.03 RSI)	-	-

¹ Value selected from table 1, p. 26.1 of 2009 ASHRAE Handbook – Fundamentals depending on surface orientation

Detail 5.1.14

Exterior and Interior Insulated 3 5/8" x 1 5/8" Steel Stud (16" o.c.) Wall Assembly with Horizontal Z-Girts (24" o.c.) Supporting Metal Cladding and R-12 Batt Insulation in Stud Cavity – Clear Wall

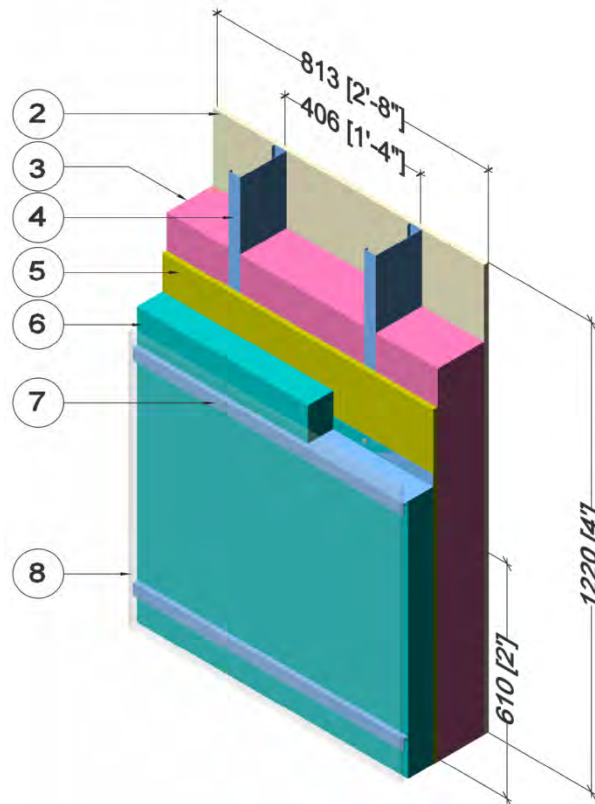

ID	Component	Thickness Inches (mm)	Conductivity Btu·in / ft ² ·hr·°F (W/m K)	Nominal Resistance hr·ft ² ·°F/Btu (m ² K/W)	Density lb/ft ³ (kg/m ³)	Specific Heat Btu/lb·°F (J/kg K)
1	Interior Film ¹	-	-	R-0.7 (0.12 RSI)	-	-
2	Gypsum Board	1/2" (13)	1.1 (0.16)	R-0.5 (0.08 RSI)	50 (800)	0.26 (1090)
3	Fiberglass Batt Insulation	3 5/8" (92)	0.31 (0.044)	R-12 (2.1 RSI)	0.9 (14)	0.17 (710)
4	3 5/8" x 1 5/8" Steel Studs	18 gauge	430 (62)	-	489 (7830)	0.12 (500)
5	Exterior Sheathing	1/2" (13)	1.1 (0.16)	R-0.5 (0.08 RSI)	50 (800)	0.26 (1090)
6	Exterior Insulation	Varies	-	R-5 to R-25 (0.88 to 4.4 RSI)	1.8 (28)	0.29 (1220)
7	Horizontal Z-girts w/ 1 1/2" Flange	18 gauge	430 (62)	-	489 (7830)	0.12 (500)
8	Metal cladding with 1/2" (13mm) vented air space is incorporated into exterior heat transfer coefficient					
9	Exterior Film ¹	-	-	R-0.7 (0.12 RSI)	-	-

¹ Value selected from table 1, p. 26.1 of 2009 ASHRAE Handbook – Fundamentals depending on surface orientation

Detail 5.1.15

Exterior and Interior Insulated 6" x 1 5/8" Steel Stud (16" o.c.) Wall Assembly with Horizontal Z-Girts (24" o.c.) and 1 1/2" Spray Foam (R-9.8) in Stud Cavity – Clear Wall

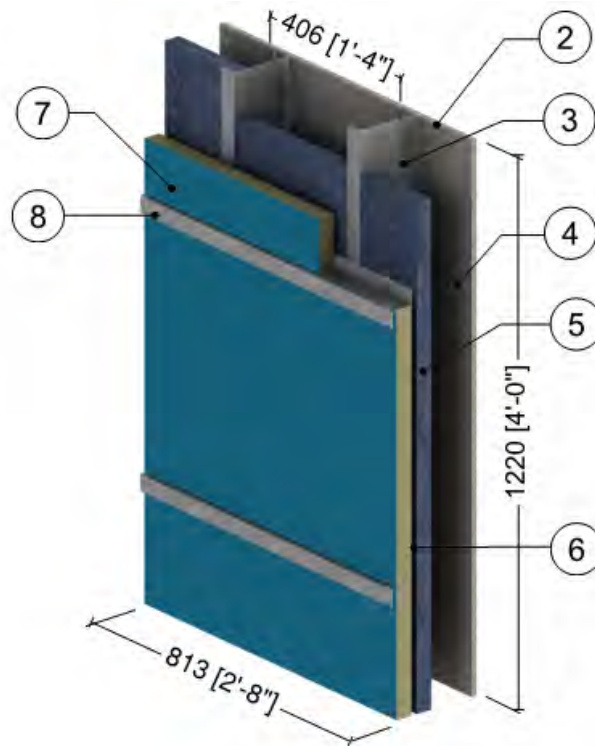

ID	Component	Thickness Inches (mm)	Conductivity Btu-in / ft ² -hr-°F (W/m K)	Nominal Resistance hr-ft ² -°F/Btu (m ² K/W)	Density lb/ft ³ (kg/m ³)	Specific Heat Btu/lb-°F (J/kg K)
1	Interior Films ¹	-	-	R-0.7 (0.12 RSI)	-	-
2	Gypsum Board	1/2" (13)	1.1 (0.16)	R-0.5 (0.08 RSI)	50 (800)	0.26 (1090)
3	6" x 1 5/8" Steel Studs (16" o.c.)	18 Gauge	250 (36)	-	489 (7830)	0.12 (500)
4	Air in Stud Cavity	4 1/2" (114)	-	R-0.9 (0.16 RSI)	0.075 (1.2)	0.24 (1000)
5	Spray Foam Insulation	1 1/2" (38)	-	R-9.8 (1.73 RSI)	-	-
6	Exterior Sheathing	1/2" (13)	1.1 (0.16)	R-0.5 (0.08 RSI)	50 (800)	0.26 (1090)
7	Exterior Polyisocyanurate Insulation	1 1/2" (38)	-	R-10.1 (1.78 RSI)	-	-
8	Horizontal Z-Girts (24" o.c.)	18 Gauge	250 (36)	-	489 (7830)	0.12 (500)
9	Metal Cladding with vented airspace incorporated into exterior heat transfer coefficient					
10	Exterior Film ¹	-	-	R-0.7 (0.12 RSI)	-	-

¹ Value selected from table 1, p. 26.1 of 2009 ASHRAE Handbook – Fundamentals depending on surface orientation

Detail 5.1.16

Exterior Insulated 3 5/8" x 1 5/8" Steel Stud (16" o.c.) Wall Assembly with Vertical Z-Girts (24" o.c.) & Horizontal Z-Girts (24" o.c.) Supporting Metal Cladding – Clear Wall

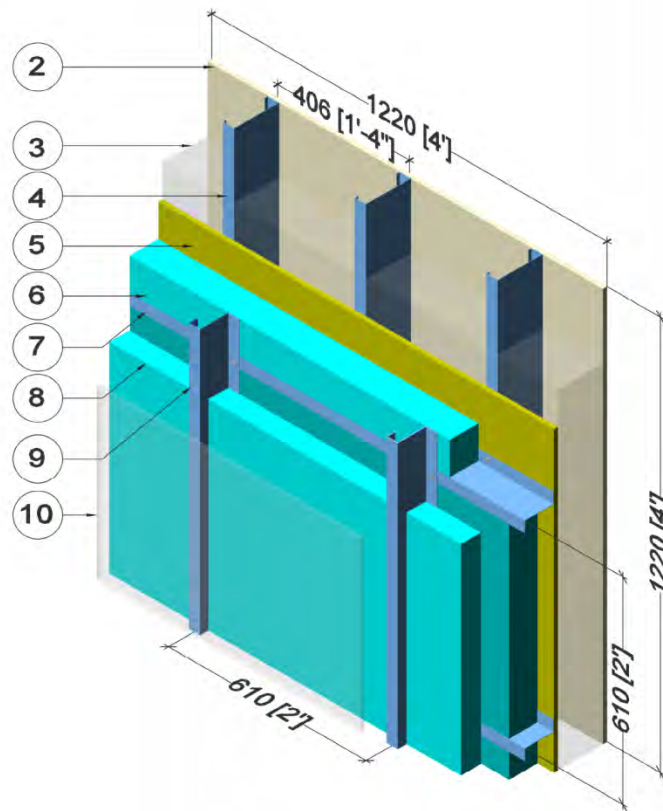

ID	Component	Thickness Inches (mm)	Conductivity Btu-in / ft ² -hr-°F (W/m K)	Nominal Resistance hr-ft ² -°F/Btu (m ² K/W)	Density lb/ft ³ (kg/m ³)	Specific Heat Btu/lb-°F (J/kg K)
1	Interior Film ¹	-	-	R-0.7 (0.12 RSI)	-	-
2	Gypsum Board	1/2" (13)	1.1 (0.16)	R-0.5 (0.08 RSI)	50 (800)	0.26 (1090)
3	Air in Stud Cavity	3 5/8" (92)	-	R-0.9 (0.16 RSI)	0.075 (1.2)	0.24 (1000)
4	3 5/8" x 1 5/8" Steel Studs	18 Gauge	430 (62)	-	489 (7830)	0.12 (500)
5	Exterior Sheathing	1/2" (13)	1.1 (0.16)	R-0.5 (0.08 RSI)	50 (800)	0.26 (1090)
6	Exterior Insulation – Horizontal Z-Girts	Varies	-	R-5 to R-25 (0.88 to 4.4 RSI)	1.8 (28)	0.29 (1220)
7	Horizontal Z-Girts w/ 1 1/2" flange	18 Gauge	430 (62)	-	489 (7830)	0.12 (500)
8	Exterior Insulation – Vertical Z-girts	1" (25)	-	R-5 (0.88 RSI)	1.8 (28)	0.29 (1220)
9	Vertical Z-Girts w/ 1 1/2" Flange	18 Gauge	430 (62)	-	489 (7830)	0.12 (500)
10	Metal cladding with 1/2" (13mm) vented air space is incorporated into exterior heat transfer coefficient					
11	Exterior Film ¹	-	-	R-0.7 (0.12 RSI)	-	-

¹ Value selected from table 1, p. 26.1 of 2009 ASHRAE Handbook – Fundamentals depending on surface orientation

Detail 5.1.17

Exterior Insulated 3 5/8" x 1 5/8" Steel Stud (16" o.c.) Wall Assembly with Intermittent Vertical Z-Girts (16" o.c.) Supporting Metal Cladding – Clear Wall

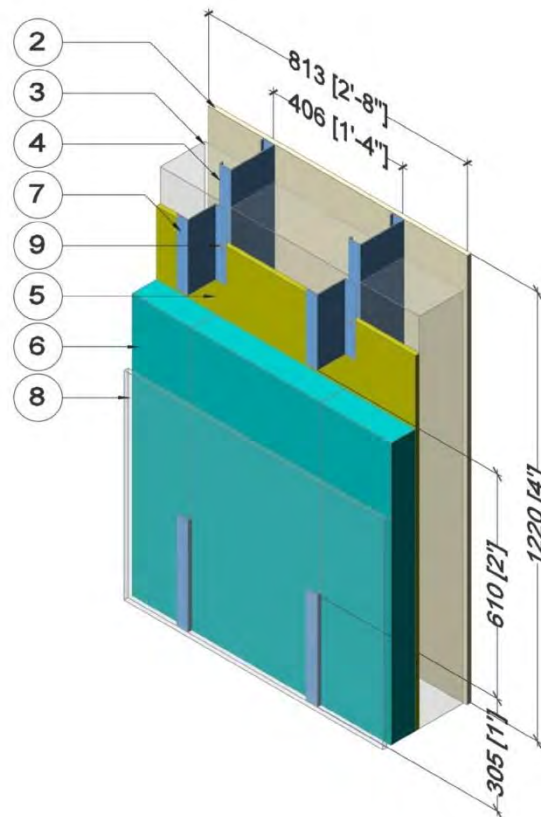

ID	Component	Thickness Inches (mm)	Conductivity Btu·in / ft ² ·hr·°F (W/m K)	Nominal Resistance hr·ft ² ·°F/Btu (m ² K/W)	Density lb/ft ³ (kg/m ³)	Specific Heat Btu/lb·°F (J/kg K)
1	Interior Film ¹	-	-	R-0.7 (0.12 RSI)	-	-
2	Gypsum Board	1/2" (13)	1.1 (0.16)	R-0.5 (0.08 RSI)	50 (800)	0.26 (1090)
3	Air in Stud Cavity	3 5/8" (92)	-	R-0.9 (0.16 RSI)	0.075 (1.2)	0.24 (1000)
4	3 5/8" x 1 5/8" Steel Studs	18 Gauge	430 (62)	-	489 (7830)	0.12 (500)
5	Exterior Sheathing	1/2" (13)	1.1 (0.16)	R-0.5 (0.08 RSI)	50 (800)	0.26 (1090)
6	Exterior Insulation	Varies	-	R-5 to R-25 (0.88 to 4.4 RSI)	1.8 (28)	0.29 (1220)
7	Intermittent vertical Z-Girts w/ 1 1/2" Flange ²	18 Gauge	430 (62)	-	489 (7830)	0.12 (500)
8	Metal cladding with 1/2" (13mm) vented air space is incorporated into exterior heat transfer coefficient					
9	Exterior Film ¹	-	-	R-0.7 (0.12 RSI)	-	-

¹ Value selected from table 1, p. 26.1 of 2009 ASHRAE Handbook – Fundamentals depending on surface orientation

² Vertical spacing of the girts Varies at 12" (304mm), 24" (610mm) & 36" (915mm)

Detail 5.1.18

Exterior Insulated 3 5/8" x 1 5/8" Steel Stud (16" o.c.) Wall Assembly with Horizontal Clips (24" o.c.) Supporting Metal Cladding – Clear Wall

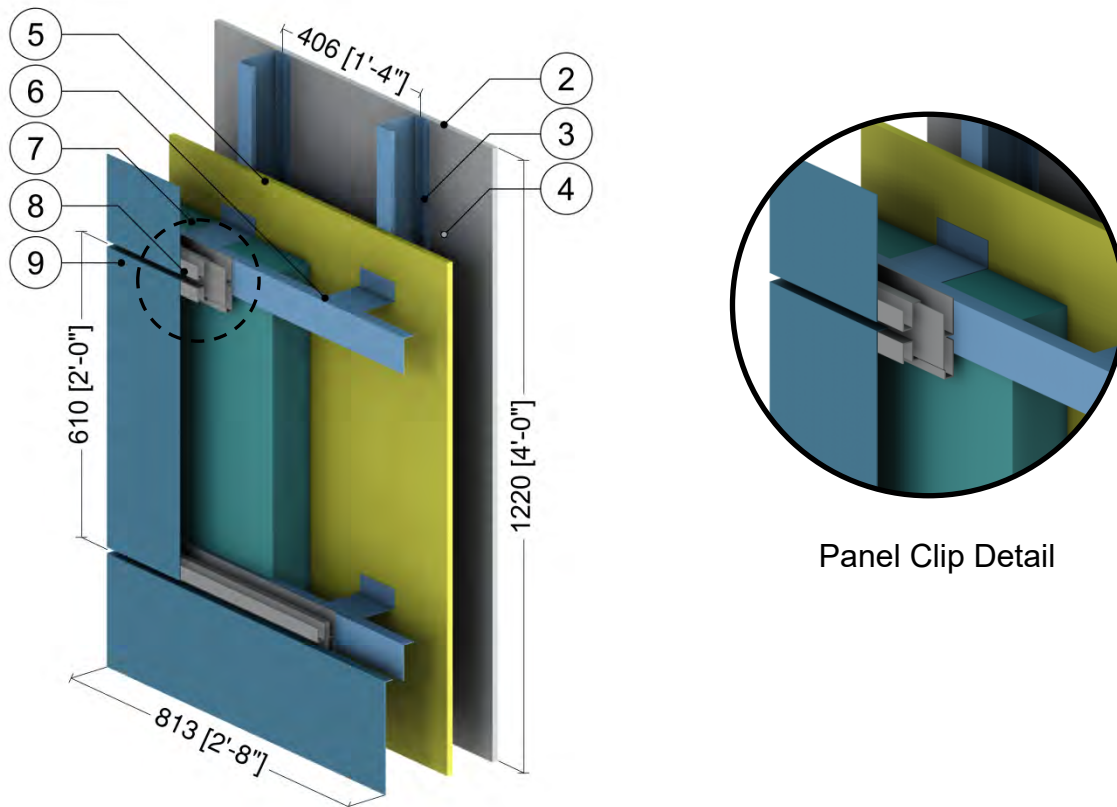

ID	Component	Thickness Inches (mm)	Conductivity Btu-in / ft ² ·hr·°F (W/m K)	Nominal Resistance hr·ft ² ·°F/Btu (m ² K/W)	Density lb/ft ³ (kg/m ³)	Specific Heat Btu/lb·°F (J/kg K)
1	Interior Film ¹	-	-	R-0.7 (0.12 RSI)	-	-
2	Gypsum Board	1/2" (13)	1.1 (0.16)	R-0.5 (0.08 RSI)	50 (800)	0.26 (1090)
3	3 5/8" x 1 5/8" Steel Studs	18 Gauge	430 (62)	-	489 (7830)	0.12 (500)
4	Air in Stud Cavity	3 5/8" (92)	-	R-0.9 (0.16 RSI)	0.075 (1.2)	0.24 (1000)
5	Exterior Sheathing	1/2" (13)	1.1 (0.16)	R-0.5 (0.09 RSI)	50 (800)	0.26 (1090)
6	Horizontal Clips w/ 1 1/2" Horizontal Rail	18 Gauge	430 (62)	-	489 (7830)	0.12 (500)
7	Exterior Insulation	Varies	-	R-15 to R-25 (2.64 to 4.4 RSI)	1.8 (28)	0.29 (1220)
8	Panel Clip	14 Gauge	430 (62)	-	489 (7830)	0.12 (500)
9	Metal Cladding with 1/2" vented airspace incorporated into exterior heat transfer coefficient					
10	Exterior Film ¹	-	-	R-0.7 (0.12 RSI)	-	-

¹ Value selected from table 1, p. 26.1 of 2009 ASHRAE Handbook – Fundamentals depending on surface orientation

Detail 5.1.19

Exterior and Interior Insulated 3 5/8" x 1 5/8" Steel Stud (16" o.c.) Wall Assembly with Horizontal Clips (24" o.c.) Supporting Metal Cladding and R-12 Batt Insulation in Stud Cavity – Clear Wall

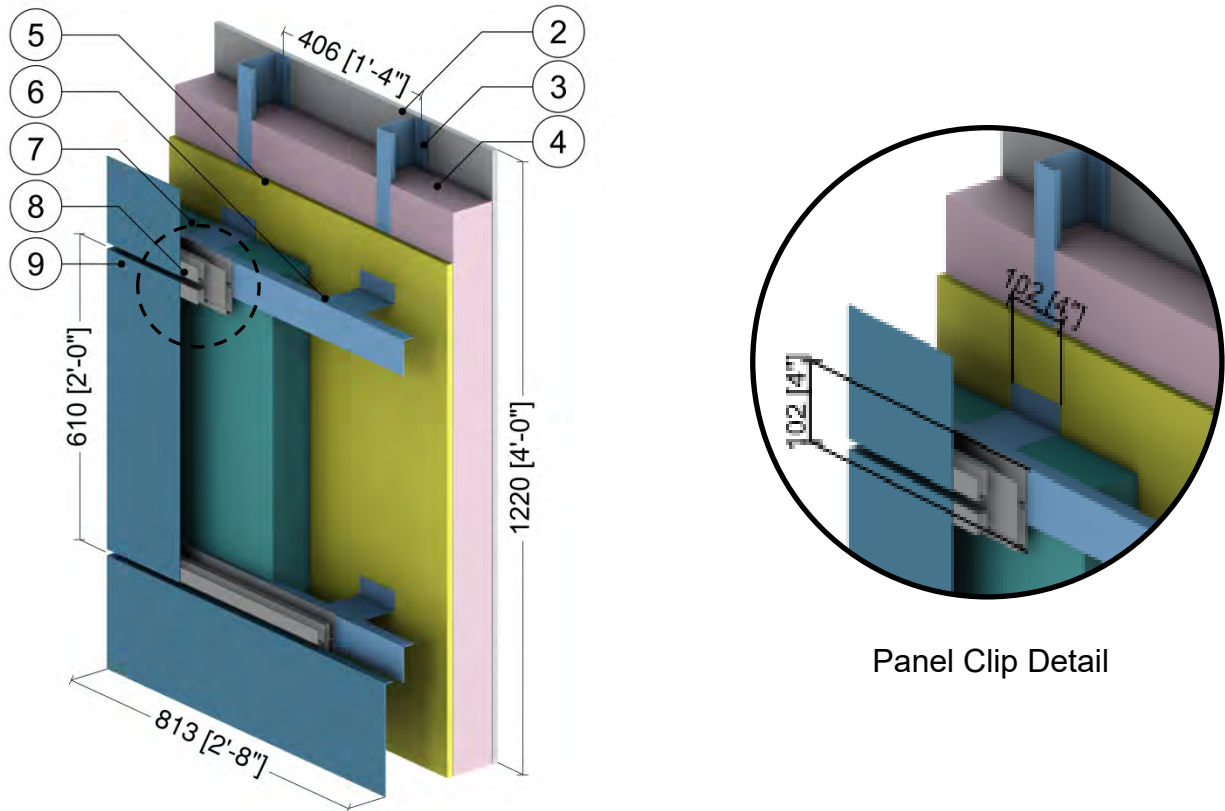

Panel Clip Detail

ID	Component	Thickness Inches (mm)	Conductivity Btu-in / ft ² -hr-°F (W/m K)	Nominal Resistance hr-ft ² -°F/Btu (m ² K/W)	Density lb/ft ³ (kg/m ³)	Specific Heat Btu/lb-°F (J/kg K)
1	Interior Film ¹	-	-	R-0.7 (0.12 RSI)	-	-
2	Gypsum Board	1/2" (13)	1.1 (0.16)	R-0.5 (0.08 RSI)	50 (800)	0.26 (1090)
3	3 5/8" x 1 5/8" Steel Studs	18 Gauge	430 (62)	-	489 (7830)	0.12 (500)
4	Fiberglass Batt Insulation	3 5/8" (92)	0.31 (0.044)	R-12 (2.1 RSI)	0.9 (14)	0.17 (710)
5	Exterior Sheathing	1/2" (13)	1.1 (0.16)	R-0.5 (0.08 RSI)	50 (800)	0.26 (1090)
6	Horizontal Clips w/ 1 1/2" Horizontal Rail	18 Gauge	430 (62)	-	489 (7830)	0.12 (500)
7	Exterior Insulation	Varies	-	R-10 to R-20 (1.76 to 3.5 RSI)	1.8 (28)	0.29 (1220)
8	Panel Clip	14 Gauge	430 (62)	-	489 (7830)	0.12 (500)
9	Metal Cladding with 1/2" vented airspace incorporated into exterior heat transfer coefficient					
10	Exterior Film ¹	-	-	R-0.7 (0.12 RSI)	-	-

¹ Value selected from table 1, p. 26.1 of 2009 ASHRAE Handbook – Fundamentals depending on surface orientation

Detail 5.1.20

Exterior and Interior Insulated 3 5/8" x 1 5/8" Steel Stud (16" o.c.) Wall Assembly with Vertical Z Clips (16" o.c.) Supporting Stucco Cladding and R-12 Batt Insulation in Stud Cavity – Clear Wall

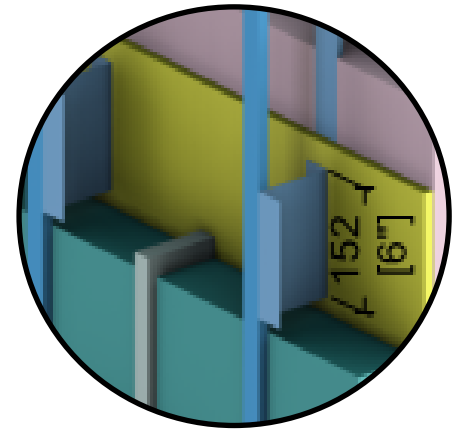
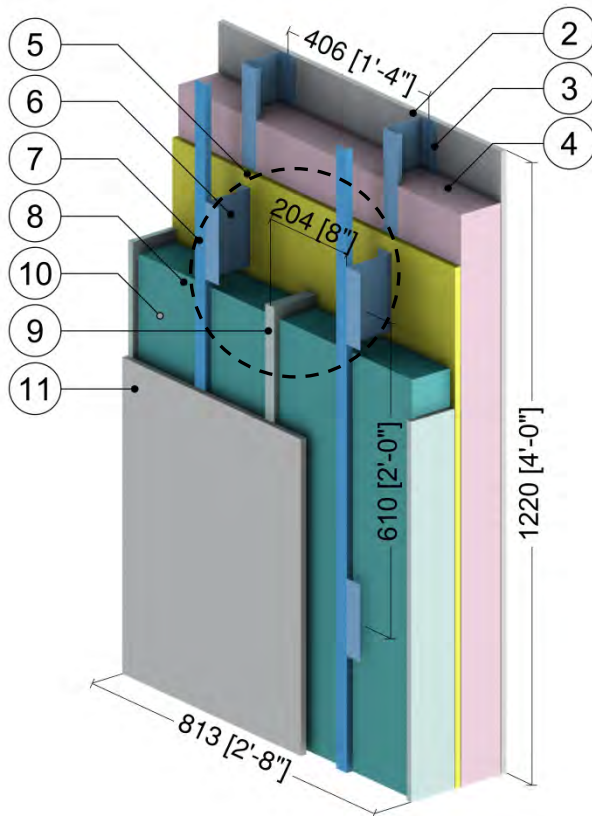

Bracing Detail

ID	Component	Thickness Inches (mm)	Conductivity Btu-in / ft ² ·hr·°F (W/m K)	Nominal Resistance hr·ft ² ·°F/Btu (m ² K/W)	Density lb/ft ³ (kg/m ³)	Specific Heat Btu/lb·°F (J/kg K)
1	Interior Film ¹	-	-	R-0.7 (0.12 RSI)	-	-
2	Gypsum Board	1/2" (13)	1.1 (0.16)	R-0.5 (0.08 RSI)	50 (800)	0.26 (1090)
3	3 5/8" x 1 5/8" Steel Studs	18 Gauge	430 (62)	-	489 (7830)	0.12 (500)
4	Fiberglass Batt Insulation	3 5/8" (92)	0.31 (0.044)	R-12 (2.1 RSI)	0.9 (14)	0.17 (710)
5	Exterior Sheathing	1/2" (13)	1.1 (0.16)	R-0.5 (0.08 RSI)	50 (800)	0.26 (1090)
6	Vertical Z-Clips with 1 1/2" Flange	18 Gauge	430 (62)	-	489 (7830)	0.12 (500)
7	Vertical Tracks	18 Gauge	430 (62)	-	489 (7830)	0.12 (500)
8	Exterior Insulation	Varies	-	R-10 to R-20 (1.76 to 3.52 RSI)	1.8 (28)	0.29 (1220)
9	Rigid Insulation Bracing	Varies	0.2 (0.029)	-	1.8 (28)	0.29 (1220)
10	Rainscreen Cavity	1/2" (13)	-	R-0.5 (0.09 RSI)	0.075 (1.2)	0.24 (1000)
11	Stucco Cement with Breather Board	1/2" (13)	6 (0.9)	R-0.1 (0.01 RSI)	120 (1922)	0.20 (850)
12	Exterior Film ¹	-	-	R-0.2 (0.03 RSI)	-	-

¹ Value selected from table 1, p. 26.1 of 2009 ASHRAE Handbook – Fundamentals depending on surface orientation

Detail 5.1.21

Exterior Insulated 6" x 1 5/8" Steel Stud (16" o.c.) Wall Assembly with Knight MFI-System (24" o.c.) Supporting Cladding – Clear Wall

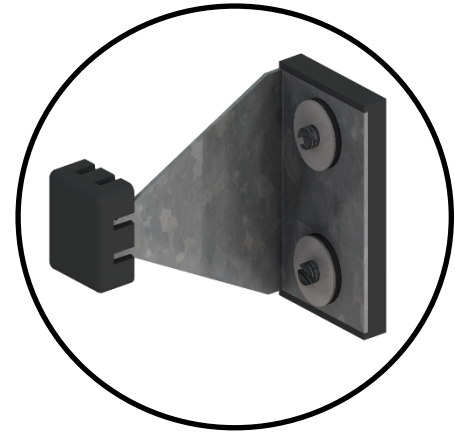
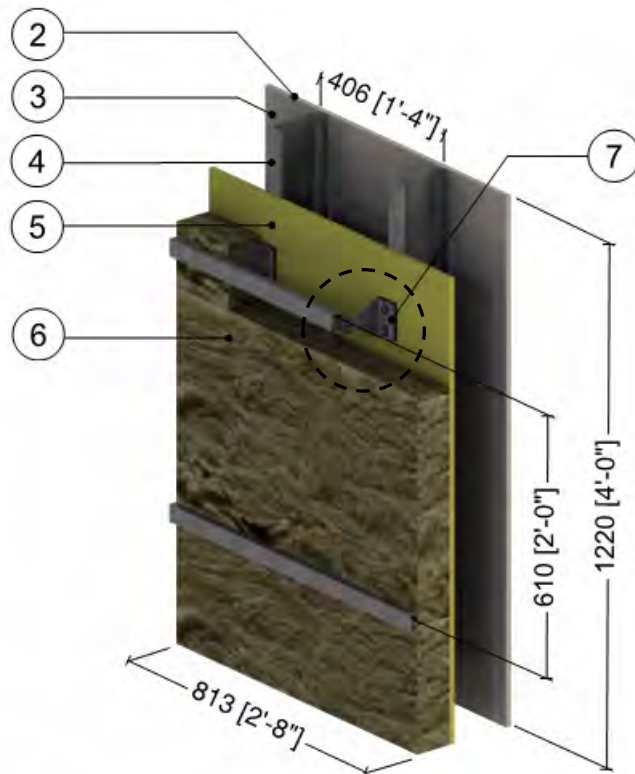

ThermaBracket Detail

ID	Component	Thickness Inches (mm)	Conductivity Btu-in / ft ² ·hr·°F (W/m K)	Nominal Resistance hr·ft ² ·°F/Btu (m ² K/W)	Density lb/ft ³ (kg/m ³)	Specific Heat Btu/lb·°F (J/kg K)
1	Interior Films ¹	-	-	R-0.7 (0.12 RSI)	-	-
2	Gypsum Board	1/2" (13)	1.1 (0.16)	R-0.5 (0.08 RSI)	50 (800)	0.26 (1090)
3	Air in Stud Cavity	6" (152)	-	R-0.9 (0.16 RSI)	0.075 (1.2)	0.24 (1000)
4	6" x 1 5/8" Steel Studs (16" o.c.)	18 Gauge	430 (62)	-	489 (7830)	0.12 (500)
5	Exterior Sheathing	1/2" (13)	1.1 (0.16)	R-0.5 (0.08 RSI)	50 (800)	0.26 (1090)
6	Exterior Insulation	Varies	0.24 (0.034)	R-8.4 to R-25.2 (1.48 to 4.44 RSI)	1.8 (28)	0.29 (1220)
7	ThermaBrackets (24" o.c. vertically)	18 Gauge	347 (50)	-	489 (7830)	0.12 (500)
8	Metal Cladding with 1/2" vented airspace incorporated into exterior heat transfer coefficient					
9	Exterior Film ¹	-	-	R-0.7 (0.12 RSI)	-	-

¹ Value selected from table 1, p. 26.1 of 2009 ASHRAE Handbook – Fundamentals depending on surface orientation

Detail 5.1.22

Exterior and Interior Insulated 6" x 1 5/8" Steel Stud (16" o.c.) Wall Assembly with Knight MFI-System (24" o.c.) Supporting Cladding and R-19 Batt Insulation in Stud Cavity – Clear Wall

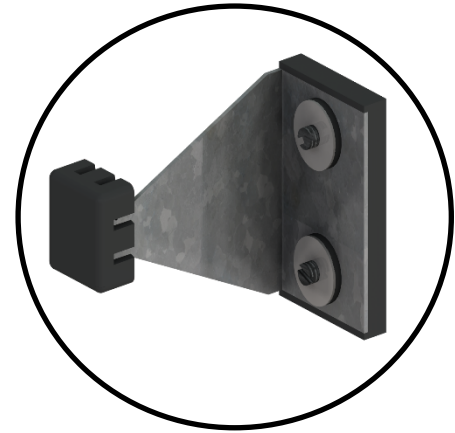
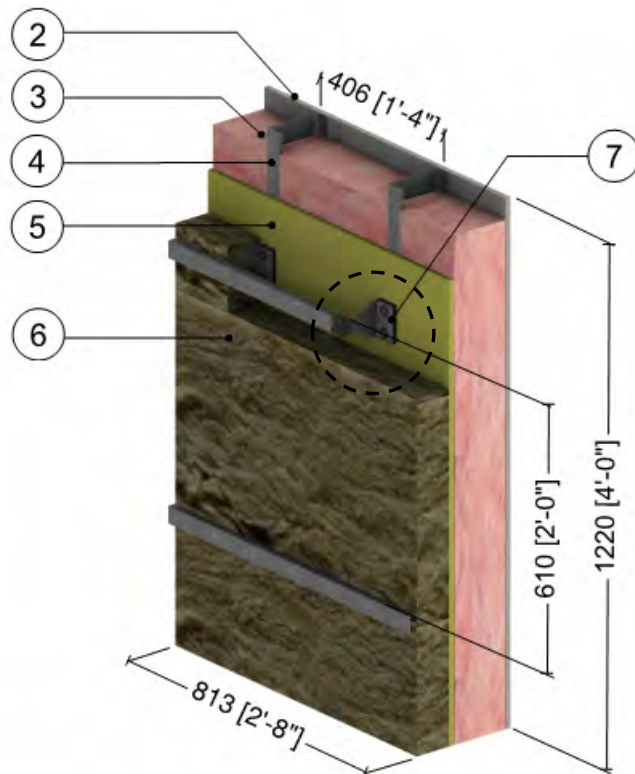

ThermaBracket Detail

ID	Component	Thickness Inches (mm)	Conductivity Btu-in / ft ² ·hr·°F (W/m K)	Nominal Resistance hr·ft ² ·°F/Btu (m ² K/W)	Density lb/ft ³ (kg/m ³)	Specific Heat Btu/lb·°F (J/kg K)
1	Interior Films ¹	-	-	R-0.7 (0.12 RSI)	-	-
2	Gypsum Board	1/2" (13)	1.1 (0.16)	R-0.5 (0.08 RSI)	50 (800)	0.26 (1090)
3	Fiberglass Batt Insulation	6" (152)	-	R-19 (3.35 RSI)	0.9 (14)	0.17 (710)
4	6" x 1 5/8" Steel Studs (16" o.c.)	18 Gauge	430 (62)	-	489 (7830)	0.12 (500)
5	Exterior Sheathing	1/2" (13)	1.1 (0.16)	R-0.5 (0.08 RSI)	50 (800)	0.26 (1090)
6	Exterior Insulation	Varies	0.24 (0.034)	R-8.4 to R-25.2 (1.48 to 4.44 RSI)	1.8 (28)	0.29 (1220)
7	ThermaBrackets (24" o.c. vertically)	18 Gauge	347 (50)	-	489 (7830)	0.12 (500)
8	Metal Cladding with 1/2" vented airspace incorporated into exterior heat transfer coefficient					
9	Exterior Film ¹	-	-	R-0.7 (0.12 RSI)	-	-

¹ Value selected from table 1, p. 26.1 of 2009 ASHRAE Handbook – Fundamentals depending on surface orientation

Detail 5.1.23 Exterior Insulated 3 5/8" x 1 5/8" Steel Stud (16" o.c.) Wall Assembly with CL-Talon 300 Clip System Supporting Cladding – Clear Wall

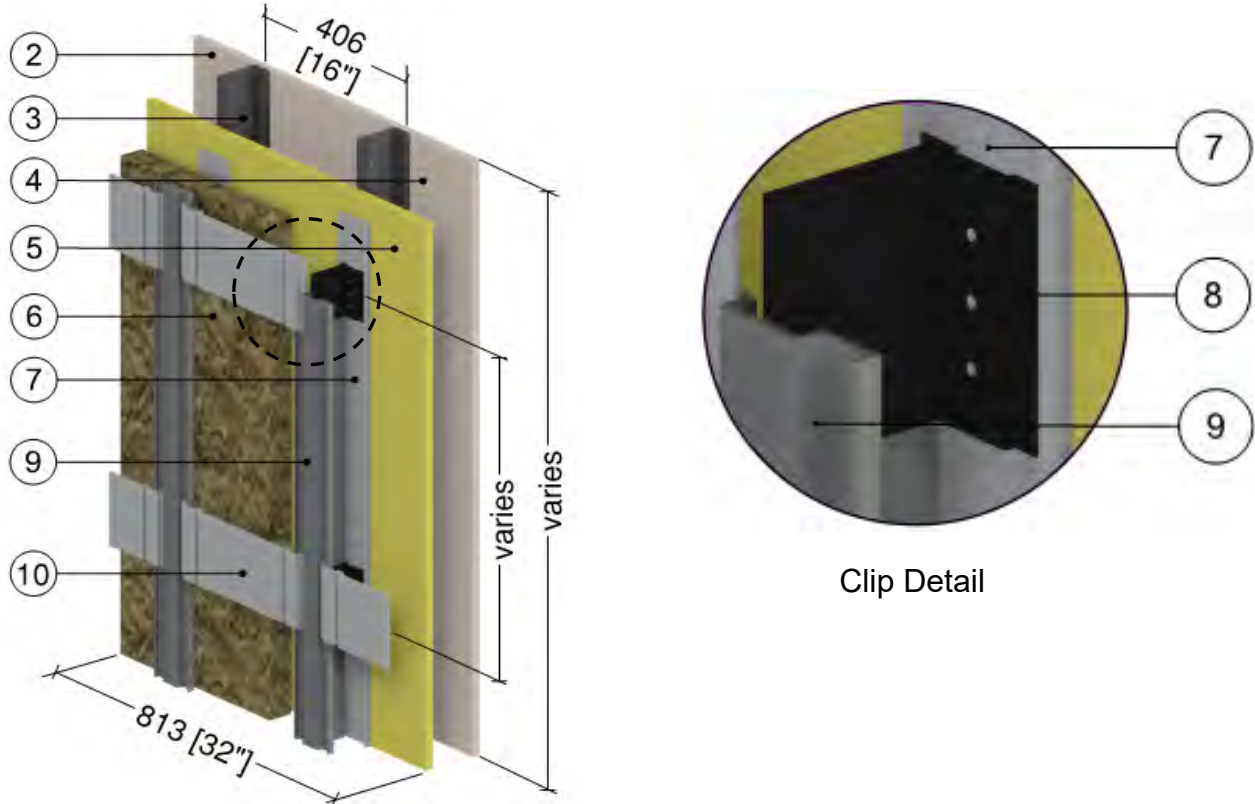

ID	Component	Thickness Inches (mm)	Conductivity Btu-in / ft ² ·hr·°F (W/m K)	Nominal Resistance hr·ft ² ·°F/Btu (m ² K/W)	Density lb/ft ³ (kg/m ³)	Specific Heat Btu/lb·°F (J/kg K)
1	Interior Film ¹	-	-	R-0.7 (0.12 RSI)	-	-
2	Gypsum Board	1/2" (13)	1.1 (0.16)	R-0.5 (0.08 RSI)	50 (800)	0.26 (1090)
3	3 5/8" x 1 5/8" Steel Studs	16 Gauge	430 (62)	-	489 (7830)	0.12 (500)
4	Air in Stud Cavity	3 5/8" (92)	-	R-0.9 (0.16 RSI)	0.075 (1.2)	0.24 (1000)
5	Exterior Sheathing	1/2" (13)	1.1 (0.16)	R-0.5 (0.08 RSI)	50 (800)	0.26 (1090)
6	Exterior Mineral Wool Insulation	2" to 4" (51 to 102)	0.24 (0.034)	R-8.4 to R-16.8 (1.48 RSI to 2.96 RSI)	4 (64)	0.20 (850)
7	Aluminum Base Track, 16" o.c. horizontally	1/8" (3.3)	1422 (205)	-	171 (2739)	0.21 (900)
8	Therme Polyamide Clip	-	1.73 (0.25)	-	-	-
9	Aluminum T-Track, 16" o.c. horizontally	1/8" (3.3)	1422 (205)	-	171 (2739)	0.21 (900)
10	Aluminum Wall Mount Supports	1/8" (3.3)	1422 (205)	-	171 (2739)	0.21 (900)
11	Generic Cladding with 1" (25mm) vented air space is incorporated into exterior heat transfer coefficient					
12	Exterior Film ¹	-	-	R-0.7 (0.12 RSI)	-	-

¹ Value selected from table 1, p. 26.1 of 2009 ASHRAE Handbook – Fundamentals depending on surface orientation

Detail 5.1.24

Exterior Insulated 3 5/8" x 1 5/8" Steel Stud (16" o.c.) Wall Assembly with Thermally Broken Aluminum Clip Supporting Cladding – Clear Wall

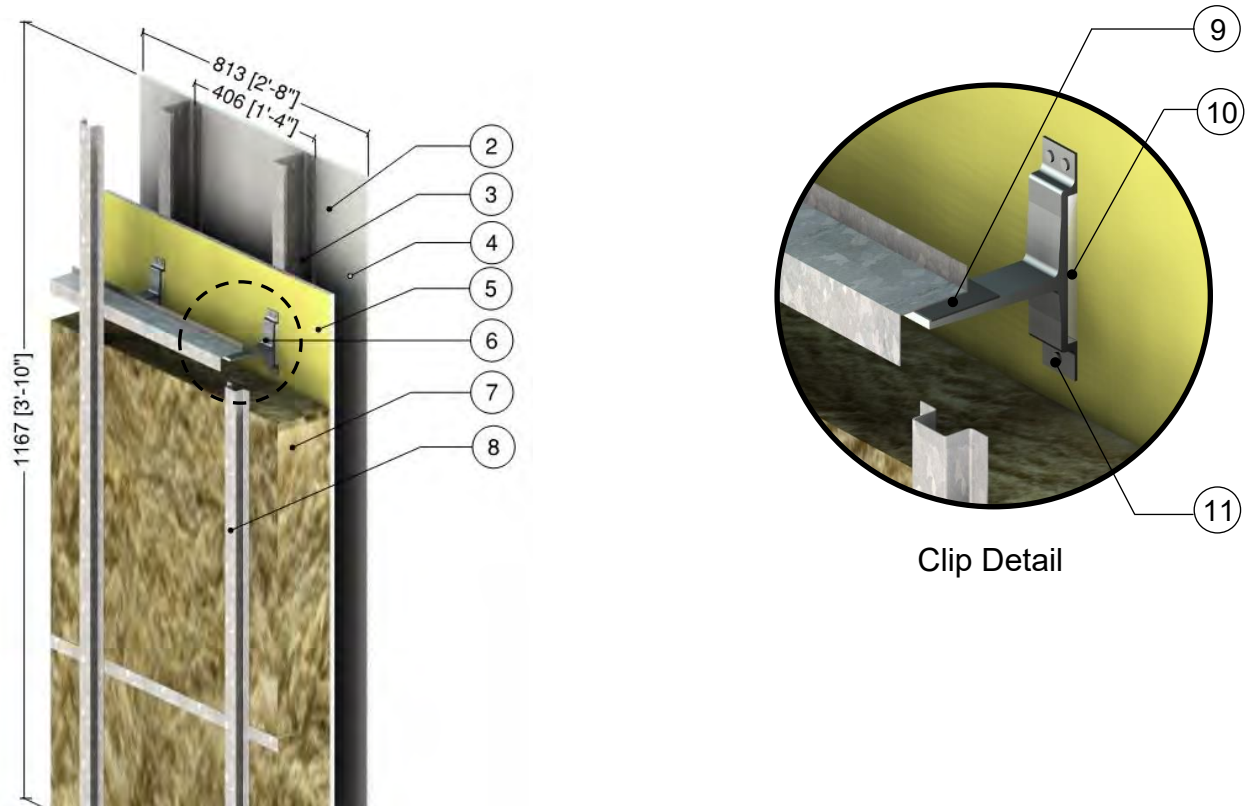

ID	Component	Thickness Inches (mm)	Conductivity Btu-in / ft ² ·hr·°F (W/m K)	Nominal Resistance hr·ft ² ·°F/Btu (m ² K/W)	Density lb/ft ³ (kg/m ³)	Specific Heat Btu/lb·°F (J/kg K)
1	Interior Film ¹	-	-	R-0.7 (0.12 RSI)	-	-
2	Gypsum Board	1/2" (13)	1.1 (0.16)	R-0.5 (0.08 RSI)	50 (800)	0.26 (1090)
3	3 5/8" x 1 5/8" Steel Studs	18 Gauge	430 (62)	-	489 (7830)	0.12 (500)
4	Air in Stud Cavity	3 5/8" (92)	-	R-0.9 (0.16 RSI)	0.075 (1.2)	0.24 (1000)
5	Exterior Sheathing	1/2" (13)	1.1 (0.16)	R-0.5 (0.08 RSI)	50 (800)	0.26 (1090)
6	Engineered Assemblies Aluminum Panel Clip (models T100 T125 150)	1/5" to 3/8" (5 to 10)	1110 (160)	-	-	-
7	Exterior Insulation	Varies	0.24 (0.034)	R-16.8 to R-25.2 (2.96 to 4.44 RSI)	1.8 (28)	0.29 (1220)
8	Vertical/Horizontal Steel Girts	18 Gauge	430 (62)	-	489 (7830)	0.12 (500)
9	Cork/Neoprene pad	1/16" (1.5)	0.329 (0.058)	R-0.15 (0.03 RSI)	-	-
10	Aerogel	3/8" (10)	0.086 (0.015)	R-3.9 (0.68 RSI)		
11	Steel Fasteners	5/16" (8) Ø	347 (50)	-	489 (7830)	0.12 (500)
12	Cladding with 1/2" (13mm) vented airspace incorporated into exterior heat transfer coefficient					
13	Exterior Film ¹	-	-	R-0.7 (0.12 RSI)	-	-

¹ Value selected from table 1, p. 26.1 of 2009 ASHRAE Handbook – Fundamentals depending on surface orientation

Detail 5.1.25

Exterior Insulated 3 5/8" x 1 5/8" Steel Stud (16"o.c.) Wall Assembly with TAC Fiber Reinforced Plastic Girts Supporting Cladding – Clear Wall

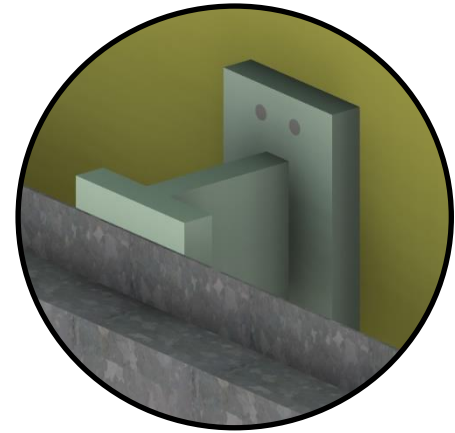
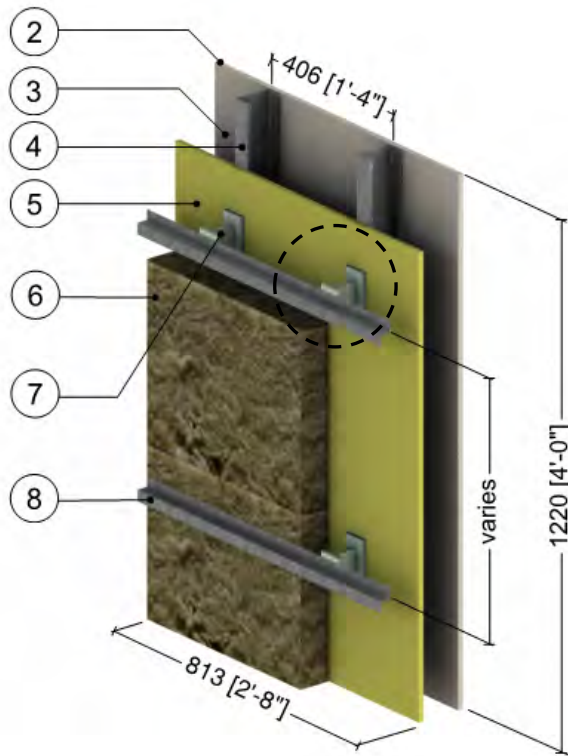

Fiber Reinforced Clip Detail

ID	Component	Thickness Inches (mm)	Conductivity Btu-in / ft ² ·hr·°F (W/m K)	Nominal Resistance hr·ft ² ·°F/Btu (m ² K/W)	Density lb/ft ³ (kg/m ³)	Specific Heat Btu/lb·°F (J/kg K)
1	Interior Films ¹	-	-	R-0.7 (0.12 RSI)	-	-
2	Gypsum Board	1/2" (13)	1.1 (0.16)	R-0.5 (0.08 RSI)	50 (800)	0.26 (1090)
3	Air in Stud Cavity	3 5/8" (92)	-	R-0.9 (0.16 RSI)	0.075 (1.2)	0.24 (1000)
4	3 5/8" x 1 5/8" Steel Studs (16"o.c.)	18 Gauge	430 (62)	-	489 (7830)	0.12 (500)
5	Exterior Sheathing	1/2" (13)	1.1 (0.16)	R-0.5 (0.08 RSI)	50 (800)	0.26 (1090)
6	Exterior Insulation	Varies	0.24 (0.034)	R-12.6 to R-25.2 (2.22 to 4.40 RSI)	489 (7830)	0.12 (500)
7	Fiber Reinforced Plastic (FRP) Girts	-	2.4 (0.35)	-	-	-
8	Horizontal Girts	18 Gauge	430 (62)	-	489 (7830)	0.12 (500)
9	Metal Cladding with 1/2" vented airspace incorporated into exterior heat transfer coefficient					
10	Exterior Film ¹	-	-	R-0.7 (0.12 RSI)	-	-

¹ Value selected from table 1, p. 26.1 of 2009 ASHRAE Handbook – Fundamentals depending on surface orientation

Detail 5.1.26

Exterior Insulated 3 5/8" x 1 5/8" Steel Stud (16" o.c.) Wall Assembly with Thermally Broken Aluminum Clip Rail System (24" o.c.) Supporting Cladding – Clear Wall

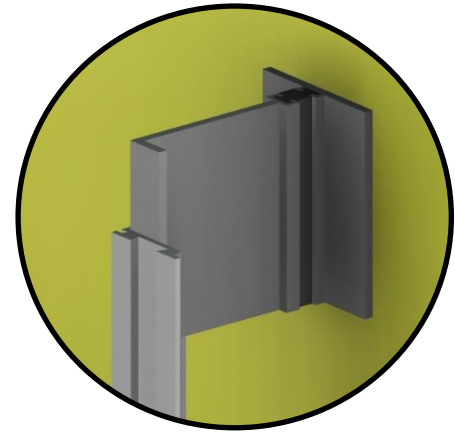
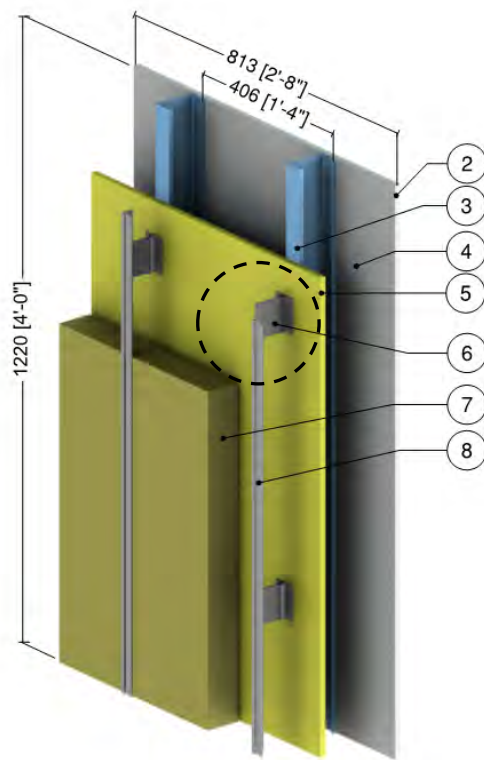

Clip Detail

ID	Component	Thickness Inches (mm)	Conductivity Btu·in / ft ² ·hr·°F (W/m K)	Nominal Resistance hr·ft ² ·°F/Btu (m ² K/W)	Density lb/ft ³ (kg/m ³)	Specific Heat Btu/lb·°F (J/kg K)
1	Interior Film ¹	-	-	R-0.7 (0.12 RSI)	-	-
2	Gypsum Board	1/2" (13)	1.1 (0.16)	R-0.5 (0.08 RSI)	50 (800)	0.26 (1090)
3	3 5/8" x 1 5/8" Steel Studs	18 Gauge	430 (62)	-	489 (7830)	0.12 (500)
4	Air in Stud Cavity	3 5/8" (92)	-	R-0.9 (0.16 RSI)	0.075 (1.2)	0.24 (1000)
5	Exterior Sheathing	1/2" (13)	1.1 (0.16)	R-0.5 (0.08 RSI)	50 (800)	0.26 (1090)
6	Longboard Aluminum Panel Clip	1/5" to 3/8" (5 to 10)	1110 (160)	-	-	-
7	Exterior Insulation	Varies	-	R-12.6 to R-25.2 (2.22 to 4.44 RSI)	1.8 (28)	0.29 (1220)
8	Vertical Steel Girts	18 Gauge	430 (62)	-	489 (7830)	0.12 (500)
9	Cladding with 1/2" (13mm) vented airspace incorporated into exterior heat transfer coefficient					
10	Exterior Film ¹	-	-	R-0.7 (0.12 RSI)	-	-

¹ Value selected from table 1, p. 26.1 of 2009 ASHRAE Handbook – Fundamentals depending on surface orientation

Detail 5.1.27

Exterior and Interior Insulated 6" x 1 5/8" Steel Stud (16" o.c.) Wall Assembly with High Compression Insulation and Through Insulation Steel Fasteners (12" o.c.) Supporting Cladding, Owens Corning ThermaFiber RainBarrier HC Max Insulation and R-20 Batt Insulation in Stud Cavity – Clear Wall

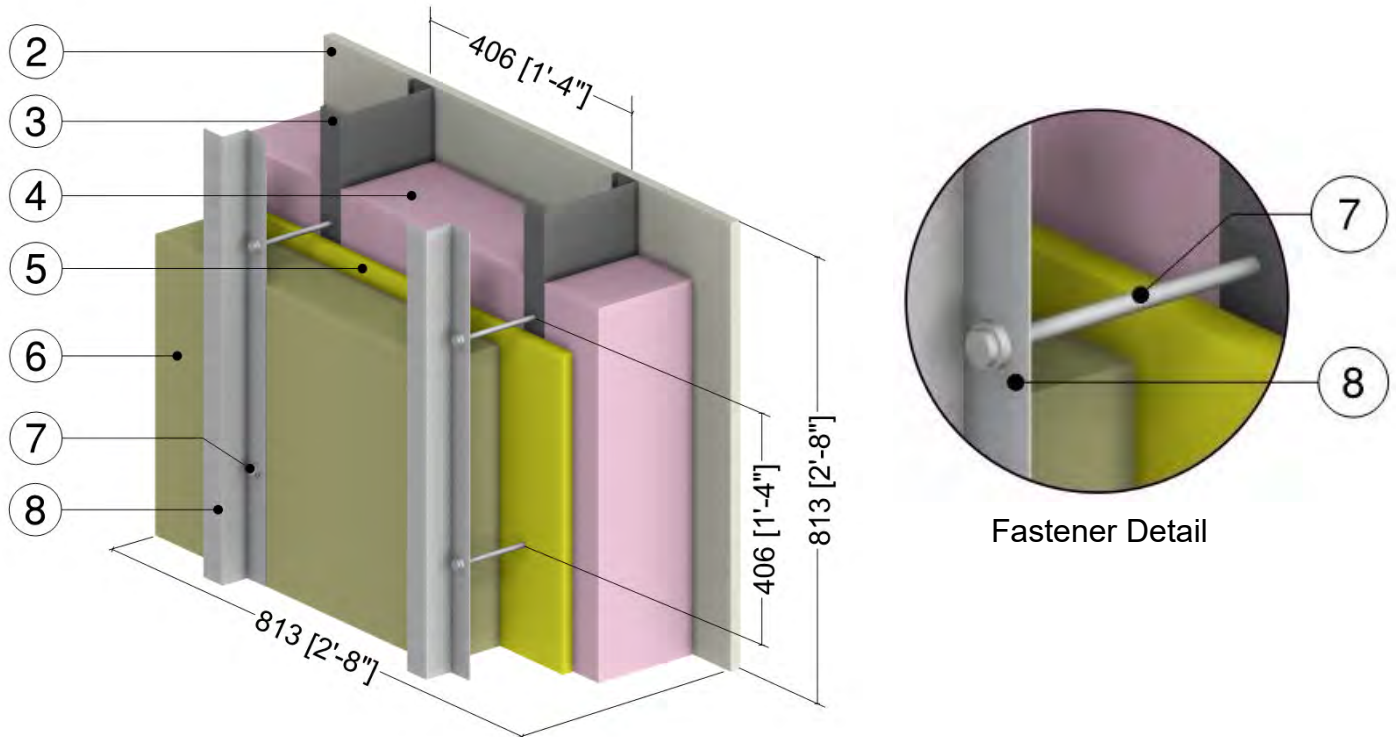

ID	Component	Thickness Inches (mm)	Conductivity Btu-in / ft ² ·hr·°F (W/m K)	Nominal Resistance hr·ft ² ·°F/Btu (m ² K/W)	Density lb/ft ³ (kg/m ³)	Specific Heat Btu/lb·°F (J/kg K)
1	Interior Film ¹	-	-	R-0.7 (0.12 RSI)	-	-
2	Gypsum Board	5/8" (16)	1.1 (0.16)	R-0.6 (0.10 RSI)	50 (800)	0.26 (1090)
3	6" x 1 5/8" Steel Studs	18 Gauge	430 (62)	-	489 (7830)	0.12 (500)
4	Ecotouch Pink Fiberglass Batt	6" (152)	0.28 (0.041)	R-20 (3.52 RSI)	0.55 (8.8)	0.17 (710)
5	Exterior Sheathing	5/8" (16)	1.1 (0.16)	R-0.6 (0.10 RSI)	50 (800)	0.26 (1090)
6	ThermaFiber RainBarrier HC Max Mineral Wool Semi Rigid Insulation	Varies	0.25 (0.036)	R-4.0 to R-16.0 (0.70 to 2.82 RSI)	11 (176)	0.20 (850)
7	#12 Steel Fasteners (12" o.c.)	0.21" (5.3) Ø	430 (62)	-	489 (7830)	0.12 (500)
8	Vertical Z-Girts	18 Gauge	430 (62)	-	489 (7830)	0.12 (500)
9	Metal Cladding with 1/2" (13 mm) vented airspace incorporated into exterior heat transfer coefficient					
10	Exterior Film ¹	-	-	R-0.7 (0.12 RSI)	-	-

¹ Value selected from table 1, p. 26.1 of 2009 ASHRAE Handbook – Fundamentals depending on surface orientation

Detail 5.1.28

Exterior and Interior Insulated 6" x 1 5/8" Steel Stud (16" o.c.) Wall Assembly with High Compression Insulation and Through Insulation Steel Fasteners (12" o.c.) Supporting Cladding, Owens Corning ThermaFiber RainBarrier HC Plus 110 Exterior Insulation and R-20 Batt Insulation in Stud Cavity – Clear Wall

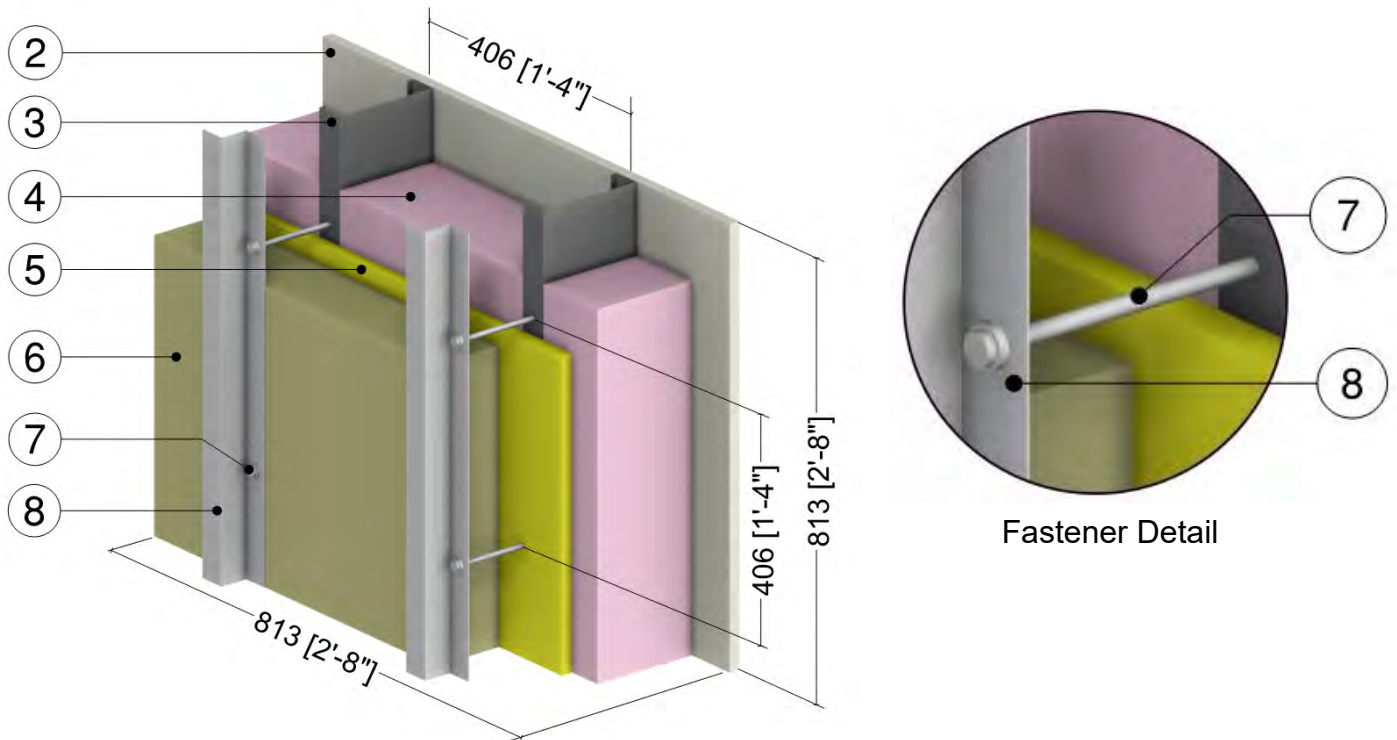

ID	Component	Thickness Inches (mm)	Conductivity Btu-in / ft ² -hr-°F (W/m K)	Nominal Resistance hr-ft ² -°F/Btu (m ² K/W)	Density lb/ft ³ (kg/m ³)	Specific Heat Btu/lb-°F (J/kg K)
1	Interior Film ¹	-	-	R-0.7 (0.12 RSI)	-	-
2	Gypsum Board	5/8" (16)	1.1 (0.16)	R-0.6 (0.10 RSI)	50 (800)	0.26 (1090)
3	6" x 1 5/8" Steel Studs	18 Gauge	430 (62)	-	489 (7830)	0.12 (500)
4	Ecotouch Pink Fiberglass Batt	6" (152)	0.28 (0.041)	R-20 (3.52 RSI)	0.55 (8.8)	0.17 (710)
5	Exterior Sheathing	5/8" (16)	1.1 (0.16)	R-0.6 (0.10 RSI)	50 (800)	0.26 (1090)
6	ThermaFiber RainBarrier HC Plus 110 Mineral Wool Semi Rigid Insulation	Varies	0.24 (0.035)	R-4.1 to R-16.4 (0.72 to 2.89 RSI)	8 (128)	0.20 (850)
7	#12 Steel Fasteners (12" o.c.)	0.21" (5.3) Ø	430 (62)	-	489 (7830)	0.12 (500)
8	Vertical Z-Girts	18 Gauge	430 (62)	-	489 (7830)	0.12 (500)
9	Metal Cladding with 1/2" (13 mm) vented airspace incorporated into exterior heat transfer coefficient					
10	Exterior Film ¹	-	-	R-0.7 (0.12 RSI)	-	-

¹ Value selected from table 1, p. 26.1 of 2009 ASHRAE Handbook – Fundamentals depending on surface orientation

Detail 5.1.29

Exterior and Interior Insulated 6" x 1 5/8" Steel Stud (16" o.c.) Wall Assembly with High Compression Insulation and Through Insulation Steel Fasteners (12" o.c.) Supporting Cladding, Owens Corning ThermaFiber RainBarrier 45 Insulation and R-20 Batt Insulation in Stud Cavity – Clear Wall

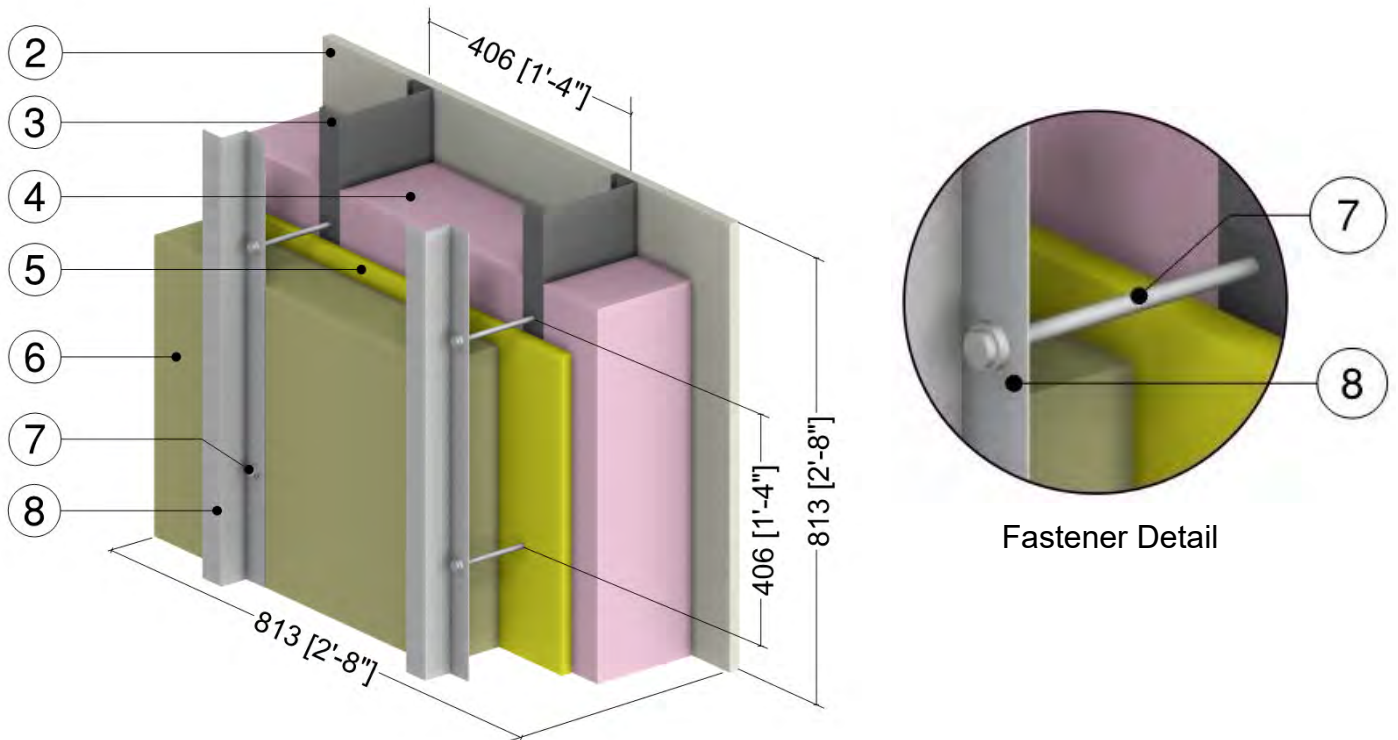

ID	Component	Thickness Inches (mm)	Conductivity Btu-in / ft ² -hr-°F (W/m K)	Nominal Resistance hr-ft ² -°F/Btu (m ² K/W)	Density lb/ft ³ (kg/m ³)	Specific Heat Btu/lb-°F (J/kg K)
1	Interior Film ¹	-	-	R-0.7 (0.12 RSI)	-	-
2	Gypsum Board	5/8" (16)	1.1 (0.16)	R-0.6 (0.10 RSI)	50 (800)	0.26 (1090)
3	6" x 1 5/8" Steel Studs	18 Gauge	430 (62)	-	489 (7830)	0.12 (500)
4	Ecotouch Pink Fiberglass Batt	6" (152)	0.28 (0.041)	R-20 (3.52 RSI)	0.55 (8.8)	0.17 (710)
5	Exterior Sheathing	5/8" (16)	1.1 (0.16)	R-0.6 (0.10 RSI)	50 (800)	0.26 (1090)
6	ThermaFiber RainBarrier 45 Mineral Wool Semi Rigid Insulation	Varies	0.24 (0.034)	R-4.2 to R-16.8 (0.74 to 2.96 RSI)	4.5 (72)	0.20 (850)
7	#12 Steel Fasteners (12" o.c.)	0.21" (5.3) Ø	430 (62)	-	489 (7830)	0.12 (500)
8	Vertical Z-Girts	18 Gauge	430 (62)	-	489 (7830)	0.12 (500)
9	Metal Cladding with 1/2" (13 mm) vented airspace incorporated into exterior heat transfer coefficient					
10	Exterior Film ¹	-	-	R-0.7 (0.12 RSI)	-	-

¹ Value selected from table 1, p. 26.1 of 2009 ASHRAE Handbook – Fundamentals depending on surface orientation

Detail 5.1.30

Exterior and Interior Insulated 6" x 1 5/8" Steel Stud (16" o.c.) Wall Assembly with High Compression Insulation and Through Insulation Steel Fasteners (12" o.c.) Supporting Cladding, Owens Corning ThermaFiber RainBarrier HC Max Insulation and R-22 Batt Insulation in Stud Cavity – Clear Wall

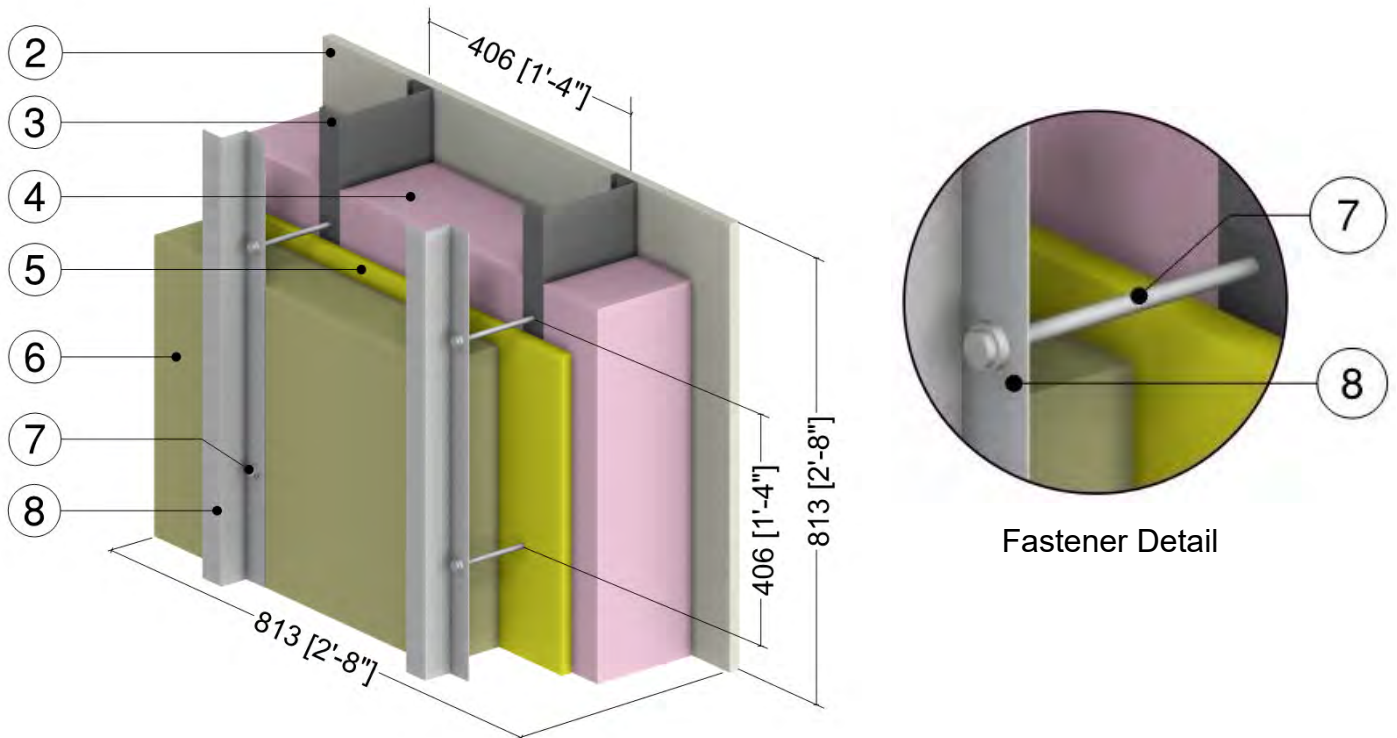

ID	Component	Thickness Inches (mm)	Conductivity Btu-in / ft ² -hr-°F (W/m K)	Nominal Resistance hr-ft ² -°F/Btu (m ² K/W)	Density lb/ft ³ (kg/m ³)	Specific Heat Btu/lb-°F (J/kg K)
1	Interior Film ¹	-	-	R-0.7 (0.12 RSI)	-	-
2	Gypsum Board	5/8" (16)	1.1 (0.16)	R-0.6 (0.10 RSI)	50 (800)	0.26 (1090)
3	6" x 1 5/8" Steel Studs	18 Gauge	430 (62)	-	489 (7830)	0.12 (500)
4	Ecotouch Pink Fiberglass Batt	6" (152)	0.27 (0.039)	R-22 (3.87 RSI)	0.91 (14.5)	0.17 (710)
5	Exterior Sheathing	5/8" (16)	1.1 (0.16)	R-0.6 (0.10 RSI)	50 (800)	0.26 (1090)
6	ThermaFiber RainBarrier HC Max Mineral Wool Semi Rigid Insulation	Varies	0.25 (0.036)	R-4.0 to R-16.0 (0.70 to 2.82 RSI)	11 (176)	0.20 (850)
7	#12 Steel Fasteners (12" o.c.)	0.21" (5.3) Ø	430 (62)	-	489 (7830)	0.12 (500)
8	Vertical Z-Girts	18 Gauge	430 (62)	-	489 (7830)	0.12 (500)
9	Metal Cladding with 1/2" (13 mm) vented airspace incorporated into exterior heat transfer coefficient					
10	Exterior Film ¹	-	-	R-0.7 (0.12 RSI)	-	-

¹ Value selected from table 1, p. 26.1 of 2009 ASHRAE Handbook – Fundamentals depending on surface orientation

Detail 5.1.31

Exterior and Interior Insulated 6" x 1 5/8" Steel Stud (16" o.c.) Wall Assembly with High Compression Insulation and Through Insulation Steel Fasteners (12" o.c.) Supporting Cladding, Owens Corning ThermaFiber RainBarrier HC Plus 110 Exterior Insulation and R-22 Batt Insulation in Stud Cavity – Clear Wall

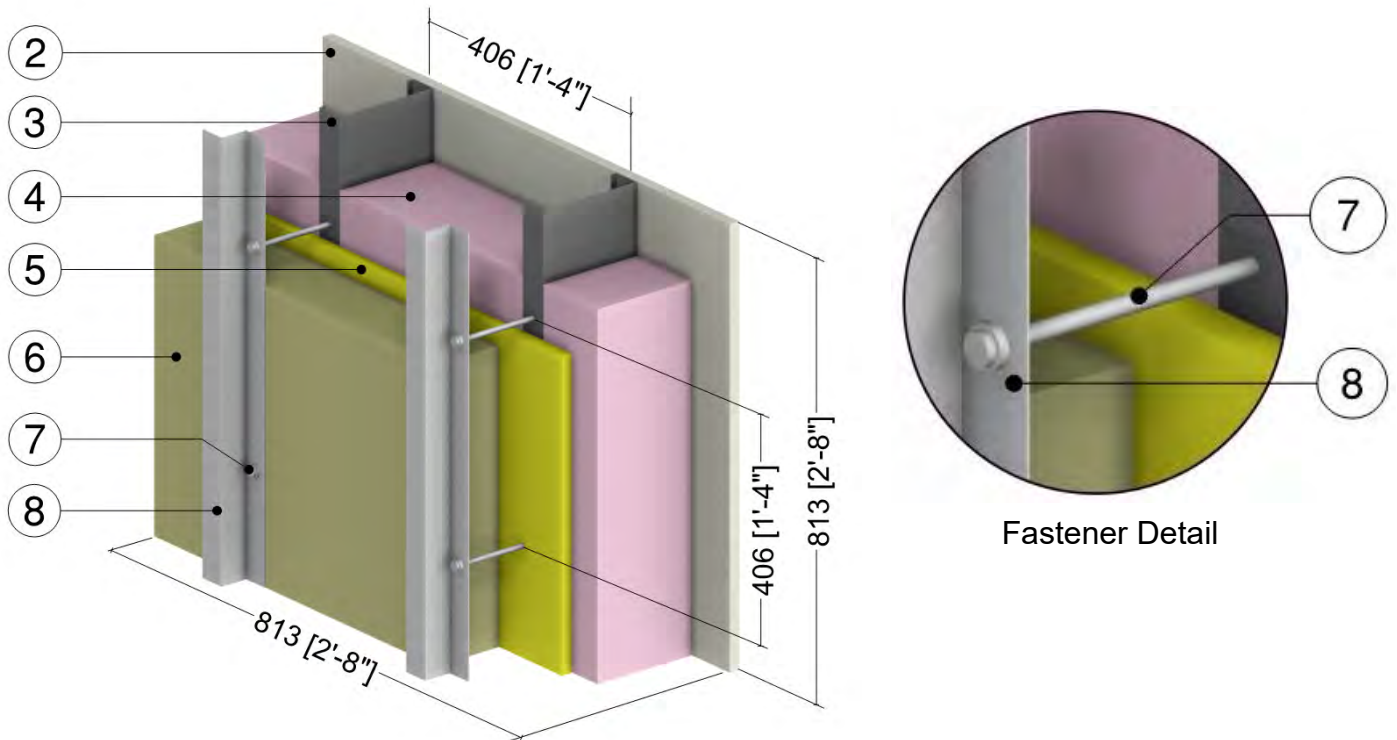

ID	Component	Thickness Inches (mm)	Conductivity Btu-in / ft ² ·hr·°F (W/m K)	Nominal Resistance hr·ft ² ·°F/Btu (m ² K/W)	Density lb/ft ³ (kg/m ³)	Specific Heat Btu/lb·°F (J/kg K)
1	Interior Film ¹	-	-	R-0.7 (0.12 RSI)	-	-
2	Gypsum Board	5/8" (16)	1.1 (0.16)	R-0.6 (0.10 RSI)	50 (800)	0.26 (1090)
3	6" x 1 5/8" Steel Studs	18 Gauge	430 (62)	-	489 (7830)	0.12 (500)
4	Ecotouch Pink Fiberglass Batt	6" (152)	0.27 (0.039)	R-22 (3.87 RSI)	0.91 (14.5)	0.17 (710)
5	Exterior Sheathing	5/8" (16)	1.1 (0.16)	R-0.6 (0.10 RSI)	50 (800)	0.26 (1090)
6	ThermaFiber RainBarrier HC Plus 110 Mineral Wool Semi Rigid Insulation	Varies	0.24 (0.035)	R-4.1 to R-16.4 (0.72 to 2.89 RSI)	8 (128)	0.20 (850)
7	#12 Steel Fasteners (12" o.c.)	0.21" (5.3) Ø	430 (62)	-	489 (7830)	0.12 (500)
8	Vertical Z-Girts	18 Gauge	430 (62)	-	489 (7830)	0.12 (500)
9	Metal Cladding with 1/2" (13 mm) vented airspace incorporated into exterior heat transfer coefficient					
10	Exterior Film ¹	-	-	R-0.7 (0.12 RSI)	-	-

¹ Value selected from table 1, p. 26.1 of 2009 ASHRAE Handbook – Fundamentals depending on surface orientation

Detail 5.1.32

Exterior and Interior Insulated 6" x 1 5/8" Steel Stud (16" o.c.) Wall Assembly with High Compression Insulation and Through Insulation Steel Fasteners (12" o.c.) Supporting Cladding, Owens Corning ThermaFiber RainBarrier 45 Insulation and R-22 Batt Insulation in Stud Cavity – Clear Wall

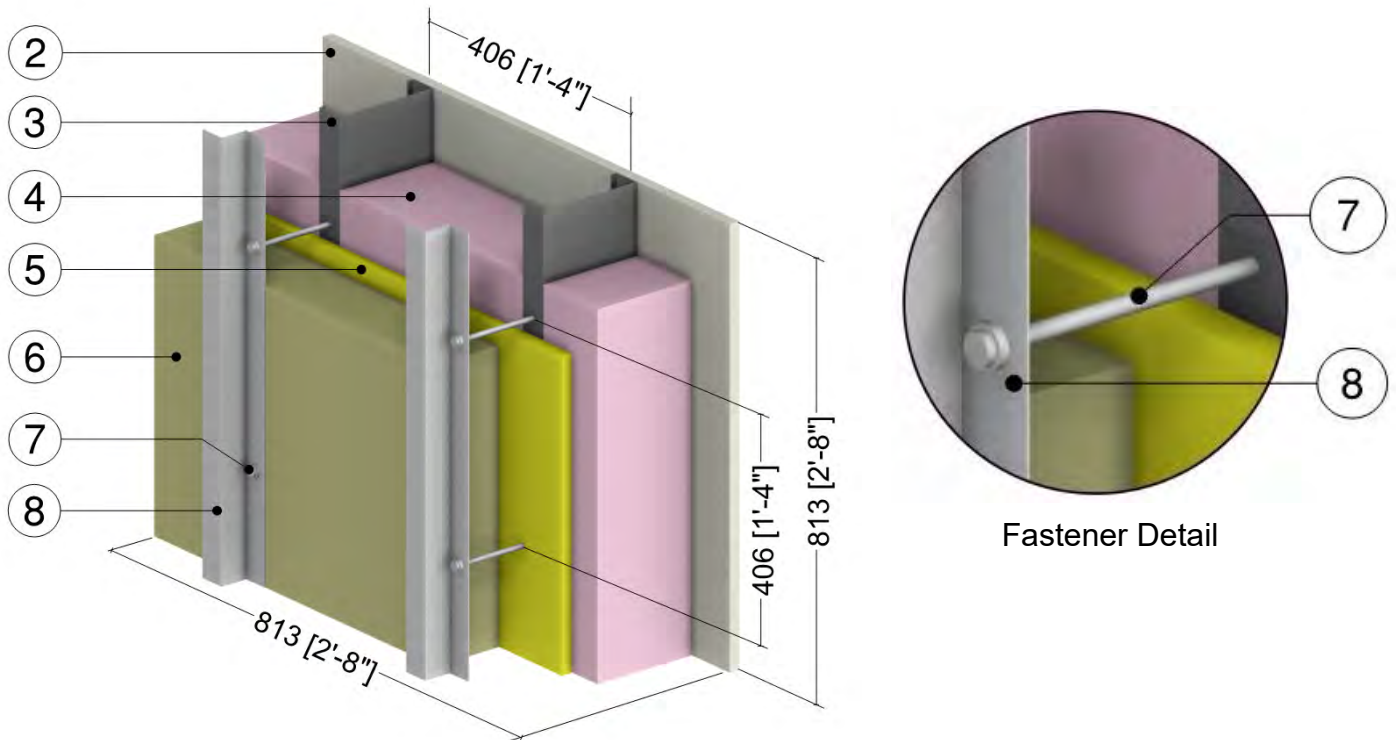

ID	Component	Thickness Inches (mm)	Conductivity Btu-in / ft ² ·hr·°F (W/m K)	Nominal Resistance hr·ft ² ·°F/Btu (m ² K/W)	Density lb/ft ³ (kg/m ³)	Specific Heat Btu/lb·°F (J/kg K)
1	Interior Film ¹	-	-	R-0.7 (0.12 RSI)	-	-
2	Gypsum Board	5/8" (16)	1.1 (0.16)	R-0.6 (0.10 RSI)	50 (800)	0.26 (1090)
3	6" x 1 5/8" Steel Studs	18 Gauge	430 (62)	-	489 (7830)	0.12 (500)
4	Ecotouch Pink Fiberglass Batt	6" (152)	0.27 (0.039)	R-22 (3.87 RSI)	0.91 (14.5)	0.17 (710)
5	Exterior Sheathing	5/8" (16)	1.1 (0.16)	R-0.6 (0.10 RSI)	50 (800)	0.26 (1090)
6	ThermaFiber RainBarrier 45 Mineral Wool Semi Rigid Insulation	Varies	0.24 (0.034)	R-4.2 to R-16.8 (0.74 to 2.96 RSI)	4.5 (72)	0.20 (850)
7	#12 Steel Fasteners (12" o.c.)	0.21" (5.3) Ø	430 (62)	-	489 (7830)	0.12 (500)
8	Vertical Z-Girts	18 Gauge	430 (62)	-	489 (7830)	0.12 (500)
9	Metal Cladding with 1/2" (13 mm) vented airspace incorporated into exterior heat transfer coefficient					
10	Exterior Film ¹	-	-	R-0.7 (0.12 RSI)	-	-

¹ Value selected from table 1, p. 26.1 of 2009 ASHRAE Handbook – Fundamentals depending on surface orientation

Detail 5.1.33

Exterior and Interior Insulated 6" x 1 5/8" Steel Stud (16" o.c.) Wall Assembly with High Compression Insulation and Through Insulation Steel Fasteners (12" o.c.) Supporting Cladding, Owens Corning ThermaFiber RainBarrier HC Max Insulation and R-24 Batt Insulation in Stud Cavity – Clear Wall

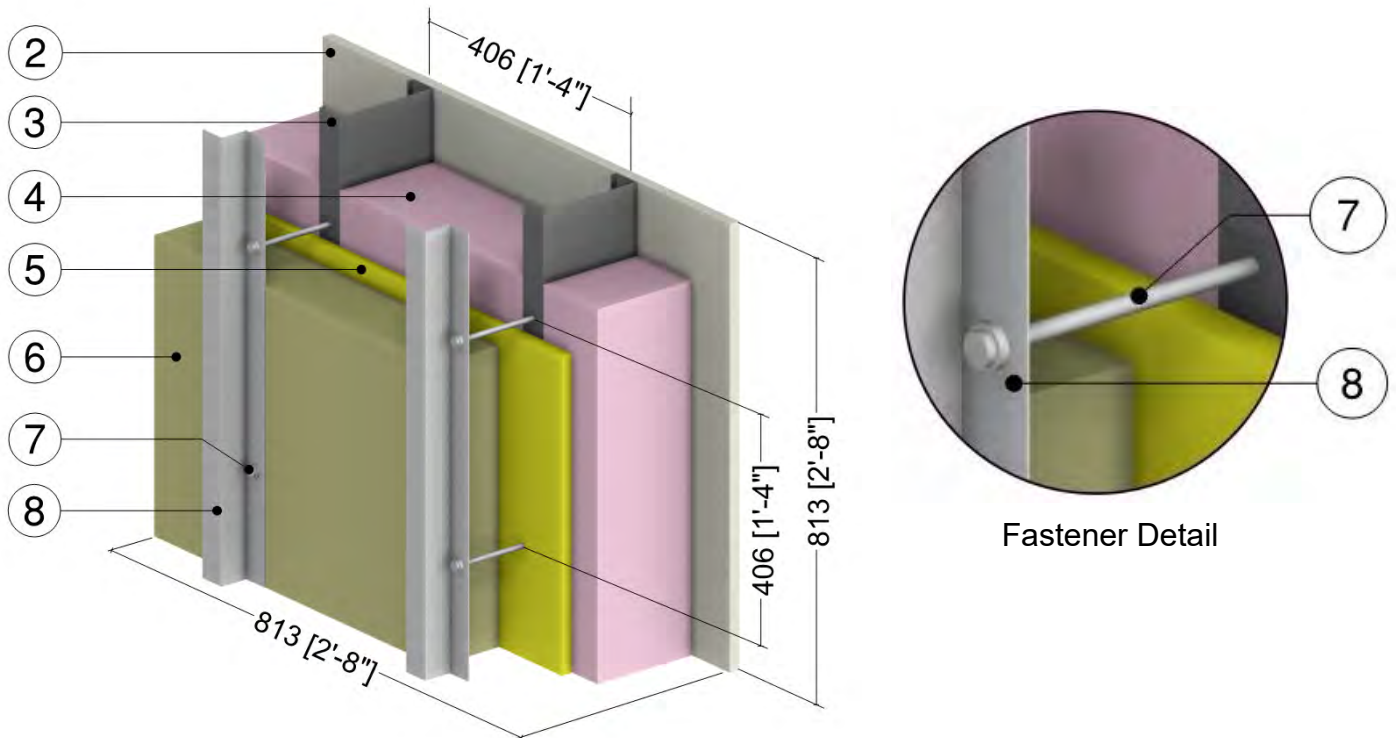

ID	Component	Thickness Inches (mm)	Conductivity Btu-in / ft ² ·hr·°F (W/m K)	Nominal Resistance hr·ft ² ·°F/Btu (m ² K/W)	Density lb/ft ³ (kg/m ³)	Specific Heat Btu/lb·°F (J/kg K)
1	Interior Film ¹	-	-	R-0.7 (0.12 RSI)	-	-
2	Gypsum Board	5/8" (16)	1.1 (0.16)	R-0.6 (0.10 RSI)	50 (800)	0.26 (1090)
3	6" x 1 5/8" Steel Studs	18 Gauge	430 (62)	-	489 (7830)	0.12 (500)
4	Ecotouch Pink Fiberglass Batt	6" (152)	0.25 (0.036)	R-24 (4.23 RSI)	1.42 (22.7)	0.17 (710)
5	Exterior Sheathing	5/8" (16)	1.1 (0.16)	R-0.6 (0.10 RSI)	50 (800)	0.26 (1090)
6	ThermaFiber RainBarrier HC Max Mineral Wool Semi Rigid Insulation	Varies	0.25 (0.036)	R-4.0 to R-16.0 (0.70 to 2.82 RSI)	11 (176)	0.20 (850)
7	#12 Steel Fasteners (12" o.c.)	0.21" (5.3) Ø	430 (62)	-	489 (7830)	0.12 (500)
8	Vertical Z-Girts	18 Gauge	430 (62)	-	489 (7830)	0.12 (500)
9	Metal Cladding with 1/2" (13 mm) vented airspace incorporated into exterior heat transfer coefficient					
10	Exterior Film ¹	-	-	R-0.7 (0.12 RSI)	-	-

¹ Value selected from table 1, p. 26.1 of 2009 ASHRAE Handbook – Fundamentals depending on surface orientation

Detail 5.1.34

Exterior and Interior Insulated 6" x 1 5/8" Steel Stud (16" o.c.) Wall Assembly with High Compression Insulation and Through Insulation Steel Fasteners (12" o.c.) Supporting Cladding, Owens Corning ThermaFiber RainBarrier HC Plus 110 Exterior Insulation and R-24 Batt Insulation in Stud Cavity – Clear Wall

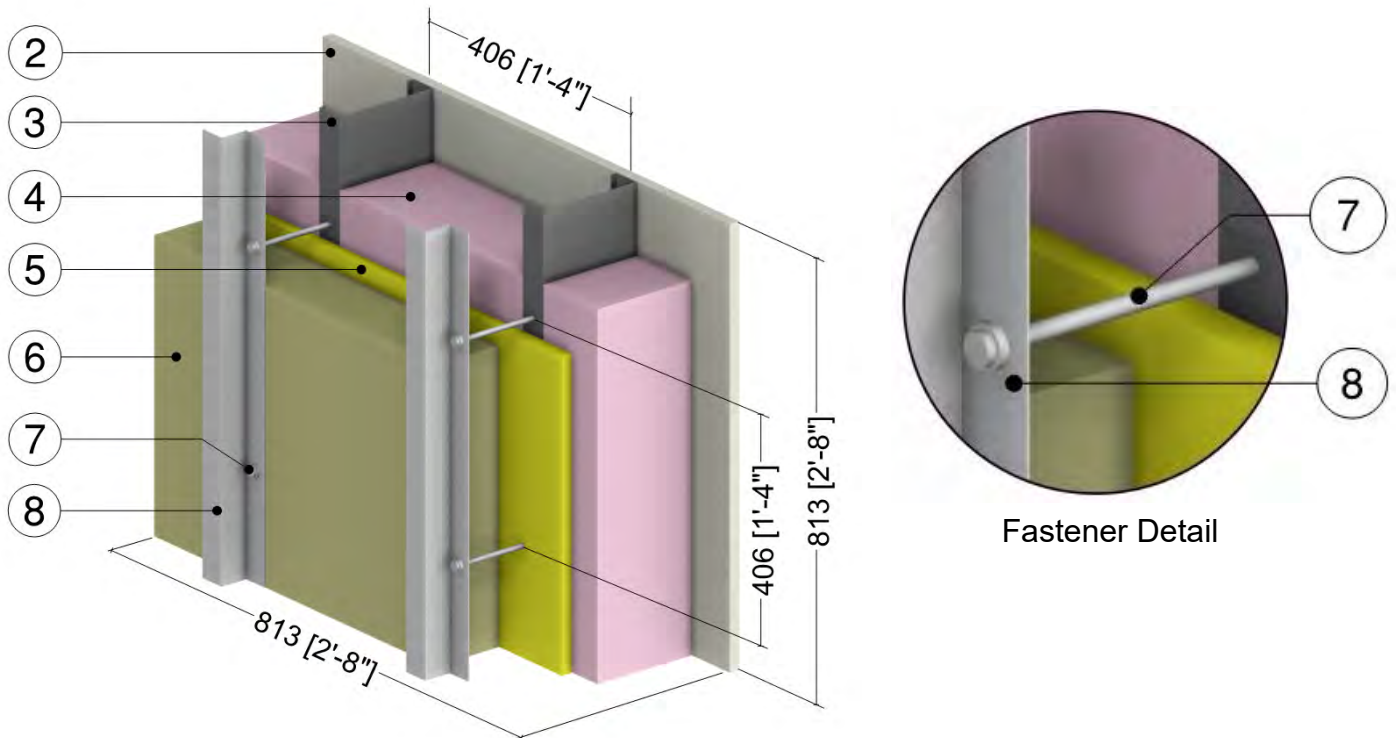

ID	Component	Thickness Inches (mm)	Conductivity Btu-in / ft ² ·hr·°F (W/m K)	Nominal Resistance hr·ft ² ·°F/Btu (m ² K/W)	Density lb/ft ³ (kg/m ³)	Specific Heat Btu/lb·°F (J/kg K)
1	Interior Film ¹	-	-	R-0.7 (0.12 RSI)	-	-
2	Gypsum Board	5/8" (16)	1.1 (0.16)	R-0.6 (0.10 RSI)	50 (800)	0.26 (1090)
3	6" x 1 5/8" Steel Studs	18 Gauge	430 (62)	-	489 (7830)	0.12 (500)
4	Ecotouch Pink Fiberglass Batt	6" (152)	0.25 (0.036)	R-24 (4.23 RSI)	1.42 (22.7)	0.17 (710)
5	Exterior Sheathing	5/8" (16)	1.1 (0.16)	R-0.6 (0.10 RSI)	50 (800)	0.26 (1090)
6	ThermaFiber RainBarrier HC Plus 110 Mineral Wool Semi Rigid Insulation	Varies	0.24 (0.035)	R-4.1 to R-16.4 (0.72 to 2.89 RSI)	8 (128)	0.20 (850)
7	#12 Steel Fasteners (12" o.c.)	0.21" (5.3) Ø	430 (62)	-	489 (7830)	0.12 (500)
8	Vertical Z-Girts	18 Gauge	430 (62)	-	489 (7830)	0.12 (500)
9	Metal Cladding with 1/2" (13 mm) vented airspace incorporated into exterior heat transfer coefficient					
10	Exterior Film ¹	-	-	R-0.7 (0.12 RSI)	-	-

¹ Value selected from table 1, p. 26.1 of 2009 ASHRAE Handbook – Fundamentals depending on surface orientation

Detail 5.1.35

Exterior and Interior Insulated 6" x 1 5/8" Steel Stud (16" o.c.) Wall Assembly with High Compression Insulation and Through Insulation Steel Fasteners (12" o.c.) Supporting Cladding, Owens Corning ThermaFiber RainBarrier 45 Insulation and R-24 Batt Insulation in Stud Cavity – Clear Wall

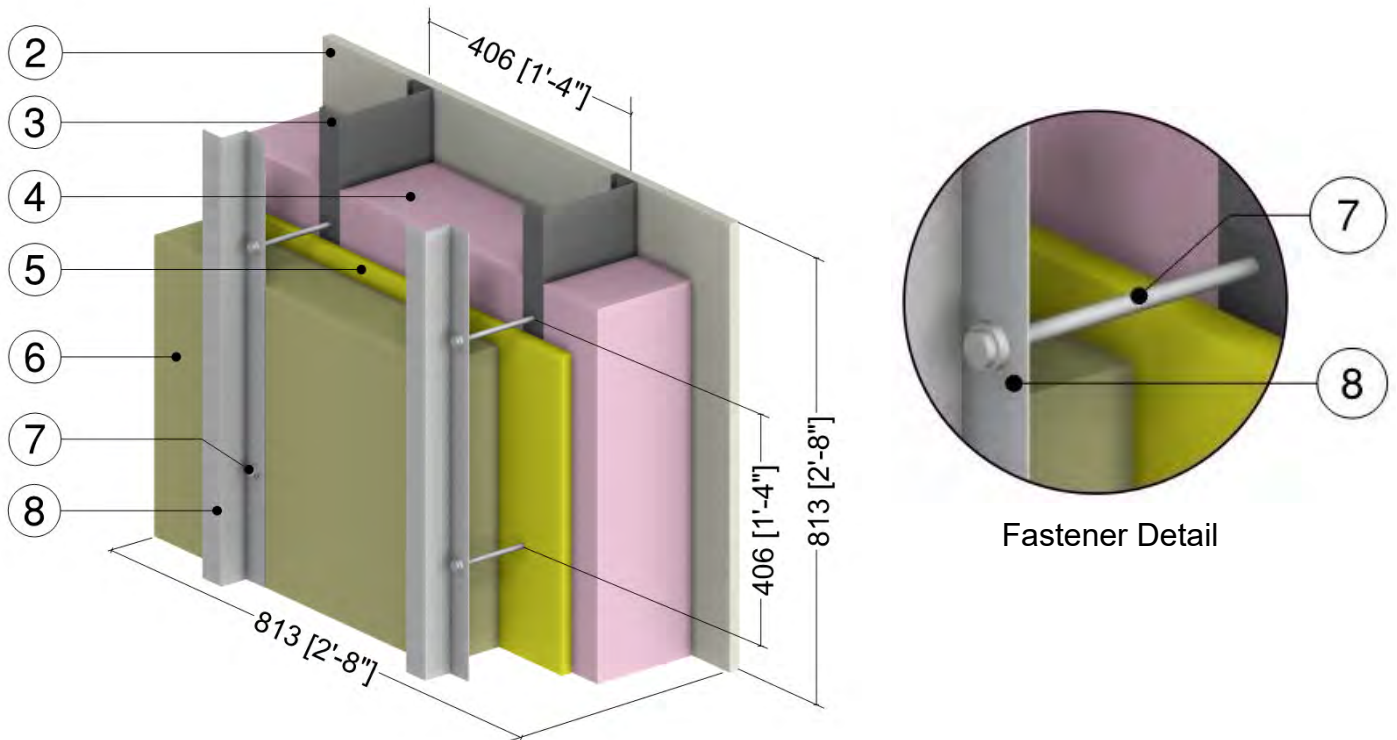

ID	Component	Thickness Inches (mm)	Conductivity Btu-in / ft ² -hr-°F (W/m K)	Nominal Resistance hr-ft ² -°F/Btu (m ² K/W)	Density lb/ft ³ (kg/m ³)	Specific Heat Btu/lb-°F (J/kg K)
1	Interior Film ¹	-	-	R-0.7 (0.12 RSI)	-	-
2	Gypsum Board	5/8" (16)	1.1 (0.16)	R-0.6 (0.10 RSI)	50 (800)	0.26 (1090)
3	6" x 1 5/8" Steel Studs	18 Gauge	430 (62)	-	489 (7830)	0.12 (500)
4	Ecotouch Pink Fiberglass Batt	6" (152)	0.25 (0.036)	R-24 (4.23 RSI)	1.42 (22.7)	0.17 (710)
5	Exterior Sheathing	5/8" (16)	1.1 (0.16)	R-0.6 (0.10 RSI)	50 (800)	0.26 (1090)
6	ThermaFiber RainBarrier 45 Mineral Wool Semi Rigid Insulation	Varies	0.24 (0.034)	R-4.2 to R-16.8 (0.74 to 2.96 RSI)	4.5 (72)	0.20 (850)
7	#12 Steel Fasteners (12" o.c.)	0.21" (5.3) Ø	430 (62)	-	489 (7830)	0.12 (500)
8	Vertical Z-Girts	18 Gauge	430 (62)	-	489 (7830)	0.12 (500)
9	Metal Cladding with 1/2" (13 mm) vented airspace incorporated into exterior heat transfer coefficient					
10	Exterior Film ¹	-	-	R-0.7 (0.12 RSI)	-	-

¹ Value selected from table 1, p. 26.1 of 2009 ASHRAE Handbook – Fundamentals depending on surface orientation

Detail 5.1.36

Exterior and Interior Insulated 6" x 1 5/8" Steel Stud (16" o.c.) Wall Assembly with Knight CI-System (8" o.c.) and 1 1/2" Spray Foam (R-9.8) in Stud Cavity – Clear Wall

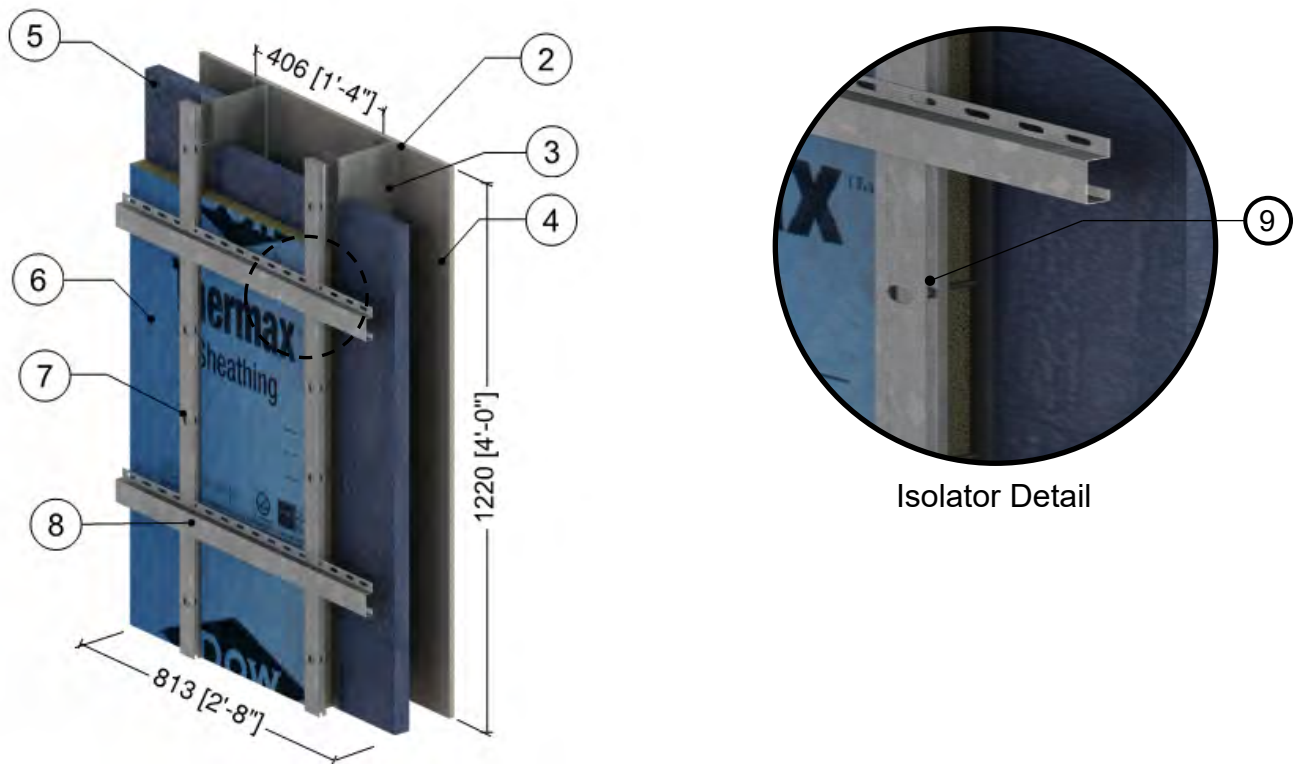

ID	Component	Thickness Inches (mm)	Conductivity Btu·in / ft ² ·hr·°F (W/m K)	Nominal Resistance hr·ft ² ·°F/Btu (m ² K/W)	Density lb/ft ³ (kg/m ³)	Specific Heat Btu/lb·°F (J/kg K)
1	Interior Films ¹	-	-	R-0.7 (0.12 RSI)	-	-
2	Gypsum Board	1/2" (13)	1.1 (0.16)	R-0.5 (0.08 RSI)	50 (800)	0.26 (1090)
3	6" x 1 5/8" Steel Studs (16"o.c.)	18 Gauge	250 (36)	-	489 (7830)	0.12 (500)
4	Air in Stud Cavity	4 1/2" (114)	-	R-0.9 (0.16 RSI)	0.075 (1.2)	0.24 (1000)
5	Spray Foam Insulation	1 1/2" (38)	-	R-9.8 (1.73 RSI)	-	-
6	Exterior Polyisocyanurate Insulation	Varies	-	R-10.1 to R-19.0 (1.78 to 3.35 RSI)	-	-
7	#12 Stainless Steel Fasteners (8" o.c.)	0.21" (5.3) Ø	12 (20)	-	489 (7830)	0.12 (500)
8	Steel Vertical and Horizontal Rails	18 Gauge	250 (36)	-	489 (7830)	0.12 (500)
9	Isolator	3/16" (4)	0.12 (0.21)	-	-	-
10	Metal Cladding with vented airspace incorporated into exterior heat transfer coefficient					
11	Exterior Film ¹	-	-	R-0.7 (0.12 RSI)	-	-

¹ Value selected from table 1, p. 26.1 of 2009 ASHRAE Handbook – Fundamentals depending on surface orientation

Detail 5.1.37

Exterior and Interior Insulated 6" x 1 5/8" Steel Stud (16" o.c.) Wall Assembly with Knight CI-System (16" o.c.) and 1 1/2" Spray Foam (R-9.8) in Stud Cavity – Clear Wall

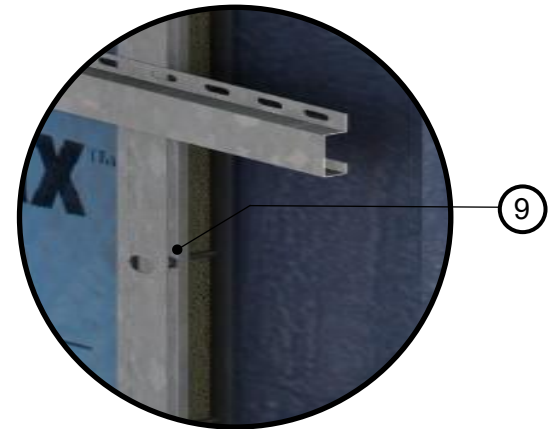
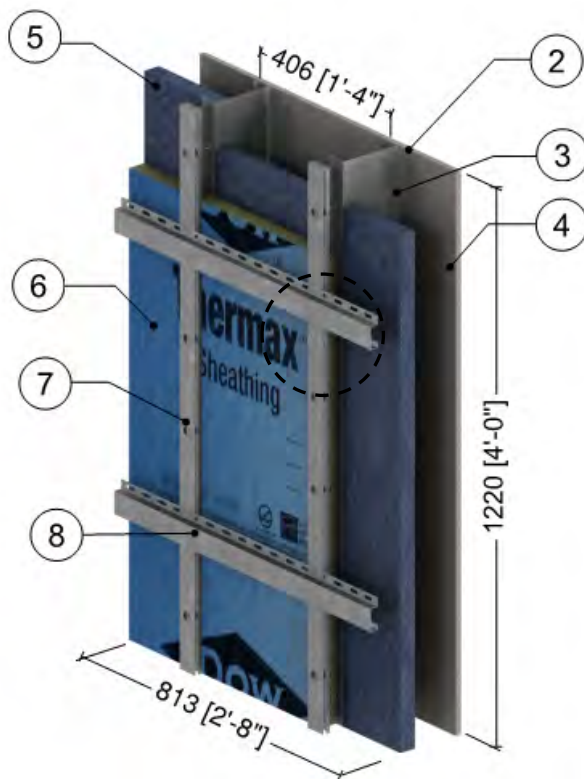

Isolator Detail

ID	Component	Thickness Inches (mm)	Conductivity Btu·in / ft ² ·hr·°F (W/m K)	Nominal Resistance hr·ft ² ·°F/Btu (m ² K/W)	Density lb/ft ³ (kg/m ³)	Specific Heat Btu/lb·°F (J/kg K)
1	Interior Films ¹	-	-	R-0.7 (0.12 RSI)	-	-
2	Gypsum Board	1/2" (13)	1.1 (0.16)	R-0.5 (0.08 RSI)	50 (800)	0.26 (1090)
3	6" x 1 5/8" Steel Studs (16" o.c.)	18 Gauge	250 (36)	-	489 (7830)	0.12 (500)
4	Air in Stud Cavity	4 1/2" (114)	-	R-0.9 (0.16 RSI)	0.075 (1.2)	0.24 (1000)
5	Spray Foam Insulation	1 1/2" (38)	-	R-9.8 (1.73 RSI)	-	-
6	Exterior Polyisocyanurate Insulation	Varies	-	R-10.1 to R-19.0 (1.78 to 3.35 RSI)	-	-
7	#12 Stainless Steel Fasteners (16" o.c.)	0.21" (5.3) Ø	12 (20)	-	489 (7830)	0.12 (500)
8	Steel Vertical and Horizontal Rails	18 Gauge	250 (36)	-	489 (7830)	0.12 (500)
9	Isolator	3/16" (4)	0.12 (0.21)	-	-	-
10	Metal Cladding with vented airspace incorporated into exterior heat transfer coefficient					
11	Exterior Film ¹	-	-	R-0.7 (0.12 RSI)	-	-

¹ Value selected from table 1, p. 26.1 of 2009 ASHRAE Handbook – Fundamentals depending on surface orientation

Detail 5.1.38

Exterior Insulated 6" x 1 5/8" Steel Stud (16" o.c.) Wall Assembly with Knight CI-System (8" o.c.) – Clear Wall

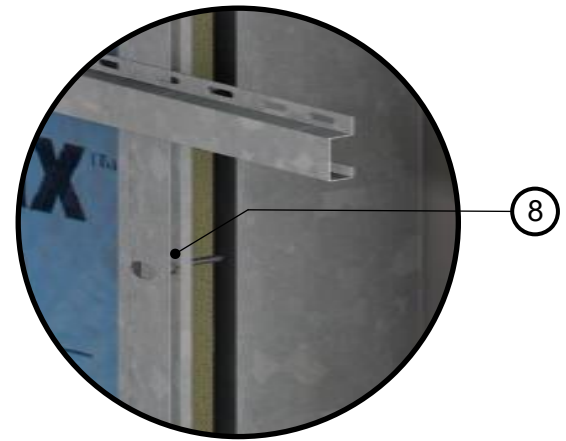
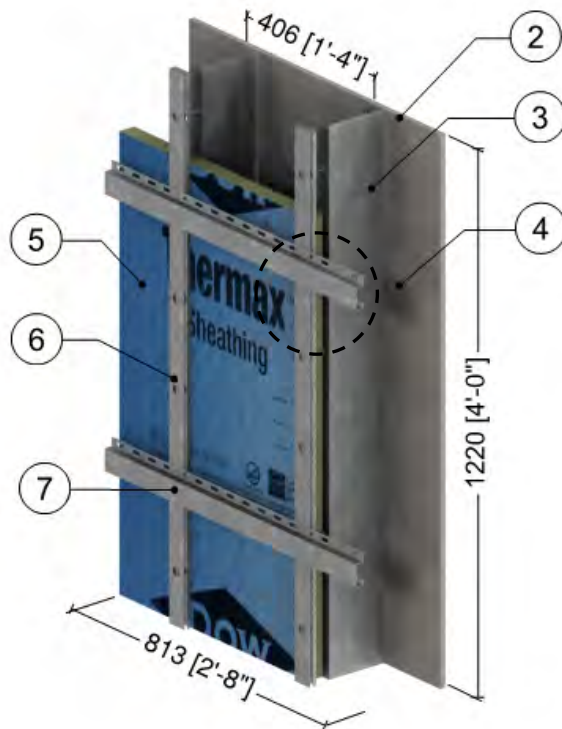

Isolator Detail

ID	Component	Thickness Inches (mm)	Conductivity Btu-in / ft ² ·hr·°F (W/m K)	Nominal Resistance hr·ft ² ·°F/Btu (m ² K/W)	Density lb/ft ³ (kg/m ³)	Specific Heat Btu/lb·°F (J/kg K)
1	Interior Films ¹	-	-	R-0.7 (0.12 RSI)	-	-
2	Gypsum Board	1/2" (13)	1.1 (0.16)	R-0.5 (0.08 RSI)	50 (800)	0.26 (1090)
3	6" x 1 5/8" Steel Studs (16" o.c.)	18 Gauge	250 (36)	-	489 (7830)	0.12 (500)
4	Air in Stud Cavity	4 1/2" (114)	-	R-0.9 (0.16 RSI)	0.075 (1.2)	0.24 (1000)
5	Exterior Polyisocyanurate Insulation	Varies	-	R-10.1 to R-19.0 (1.78 to 3.35 RSI)	-	-
6	#12 Stainless Steel Fasteners (8" o.c.)	0.21" (5.3) Ø	12 (20)	-	489 (7830)	0.12 (500)
7	Steel Vertical and Horizontal Rails	18 Gauge	250 (36)	-	489 (7830)	0.12 (500)
8	Isolator	3/16" (4)	0.12 (0.21)	-	-	-
9	Metal Cladding with vented airspace incorporated into exterior heat transfer coefficient					
10	Exterior Film ¹	-	-	R-0.7 (0.12 RSI)	-	-

¹ Value selected from table 1, p. 26.1 of 2009 ASHRAE Handbook – Fundamentals depending on surface orientation

Detail 5.1.39

Exterior Insulated 3 5/8" x 1 5/8" Steel Stud (16" o.c.) Wall Assembly with R-TEC CI Bracket System Supporting Vertical Sub-girts – Clear Wall

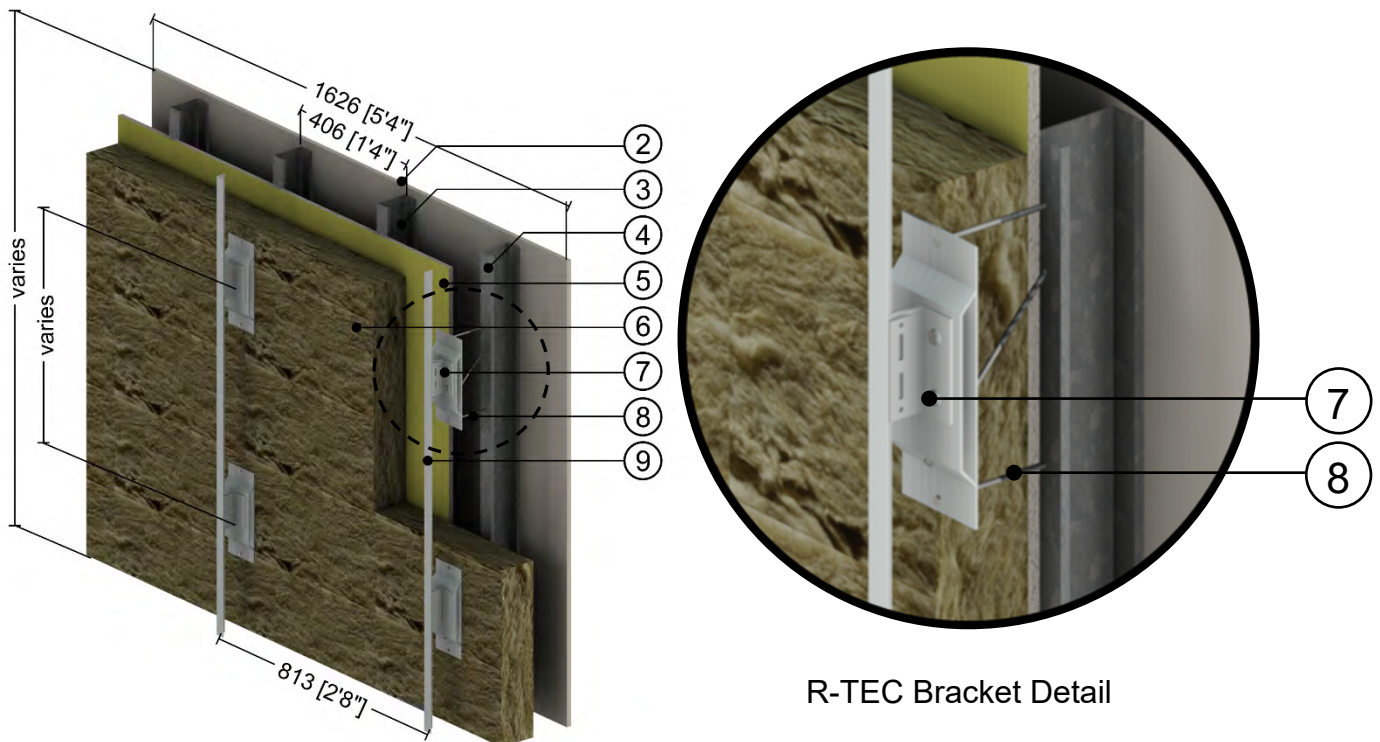

R-TEC Bracket Detail

ID	Component	Thickness Inches (mm)	Conductivity Btu-in / ft ² ·hr·°F (W/m K)	Nominal Resistance hr·ft ² ·°F/Btu (m ² K/W)	Density lb/ft ³ (kg/m ³)	Specific Heat Btu/lb·°F (J/kg K)
1	Interior Film ¹	-	-	R-0.7 (0.12 RSI)	-	-
2	Gypsum Board	1/2" (13)	1.1 (0.16)	R-0.5 (0.08 RSI)	50 (800)	0.26 (1090)
3	Air in Stud Cavity	3 5/8" (92)	-	R-0.9 (0.16 RSI)	0.075 (1.2)	0.24 (1000)
4	3 5/8" x 1 5/8" Steel Studs	18 Gauge	430 (62)	-	489 (7830)	0.12 (500)
5	Exterior Sheathing	1/2" (13)	1.1 (0.16)	R-0.5 (0.08 RSI)	50 (800)	0.26 (1090)
6	Exterior Mineral Wool Insulation	3" to 6" (76 to 152)	0.24 (0.034)	R-12.6 to R-25.2 (2.22 RSI to 4.44 RSI)	4 (64)	0.20 (850)
7	R-TEC CI Bracket Aluminum 6063	-	1390 (200)	-	168 (2700)	0.22 (900)
8	#14 Stainless Steel Fasteners	1/4" (6) Ø	118 (17)	-	500 (8000)	0.13 (530)
9	Vertical Sub-girt	0.09" (2.2)	1390 (200)	-	168 (2700)	0.22 (900)
10	Generic Cladding with 1/2" (13mm) vented air space is incorporated into exterior heat transfer coefficient					
11	Exterior Film ¹	-	-	R-0.7 (0.12 RSI)	-	-

¹ Value selected from table 1, p. 26.1 of 2009 ASHRAE Handbook – Fundamentals depending on surface orientation

Detail 5.1.40

Exterior and Interior Insulated 3 5/8" x 1 5/8" Steel Stud (16" o.c.) Wall Assembly with R-TEC CI Bracket System Supporting Vertical Sub-girts and R-13 Batt Insulation in Stud Cavity – Clear Wall

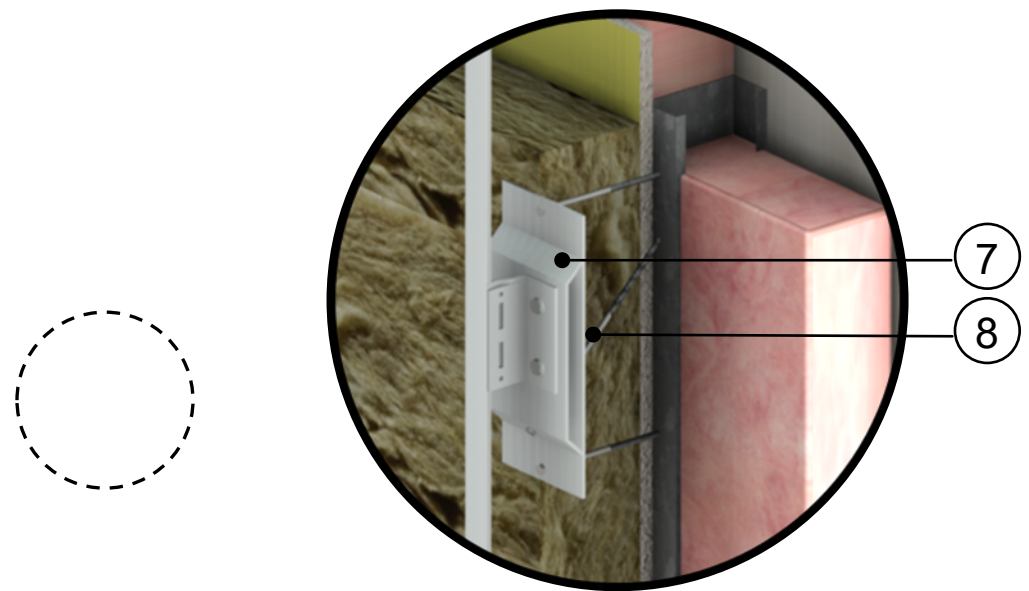

R-TEC Bracket Detail

ID	Component	Thickness Inches (mm)	Conductivity Btu-in / ft ² -hr-°F (W/m K)	Nominal Resistance hr-ft ² -°F/Btu (m ² K/W)	Density lb/ft ³ (kg/m ³)	Specific Heat Btu/lb-°F (J/kg K)
1	Interior Film ¹	-	-	R-0.7 (0.12 RSI)	-	-
2	Gypsum Board	1/2" (13)	1.1 (0.16)	R-0.5 (0.08 RSI)	50 (800)	0.26 (1090)
3	Fiberglass Batt Insulation	3 5/8" (92)	0.28 (0.040)	R-13 (2.29 RSI)	0.9 (14)	0.17 (710)
4	3 5/8" x 1 5/8" Steel Studs	18 Gauge	430 (62)	-	489 (7830)	0.12 (500)
5	Exterior Sheathing	1/2" (13)	1.1 (0.16)	R-0.5 (0.08 RSI)	50 (800)	0.26 (1090)
6	Exterior Mineral Wool Insulation	3" to 6" (76 to 152)	0.24 (0.034)	R-12.6 to R-25.2 (2.22 RSI to 4.44 RSI)	4 (64)	0.20 (850)
7	R-TEC CI Bracket Aluminum 6063	-	1390 (200)	-	168 (2700)	0.22 (900)
8	#14 Stainless Steel Fasteners	1/4" (6) Ø	118 (17)	-	500 (8000)	0.13 (530)
9	Vertical Sub-girt	0.09" (2.2)	1390 (200)	-	168 (2700)	0.22 (900)
10	Generic Cladding with 1/2" (13mm) vented air space is incorporated into exterior heat transfer coefficient					
11	Exterior Film ¹	-	-	R-0.7 (0.12 RSI)	-	-

¹ Value selected from table 1, p. 26.1 of 2009 ASHRAE Handbook – Fundamentals depending on surface orientation

Detail 5.1.41

Exterior Insulated 3 5/8" x 1 5/8" Steel Stud (16" o.c.) Wall Assembly with Thermally Broken ISO Clip System Supporting Vertical Sub-girts – Clear Wall

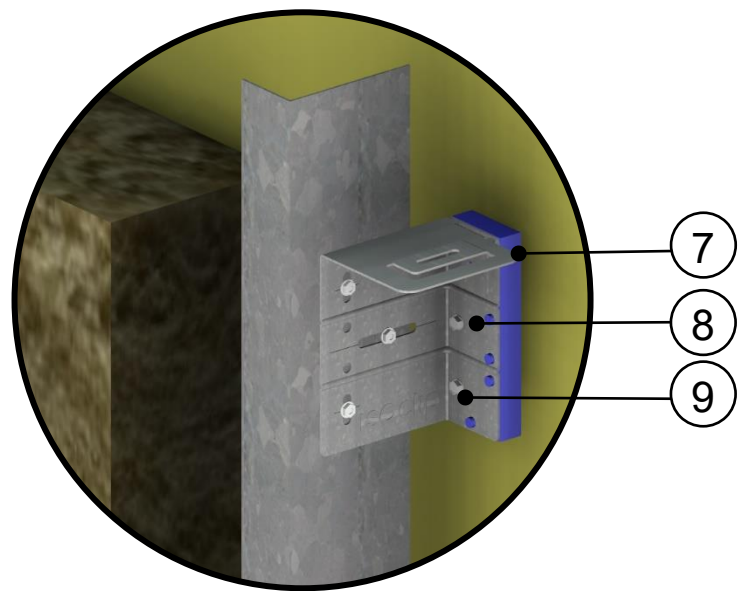
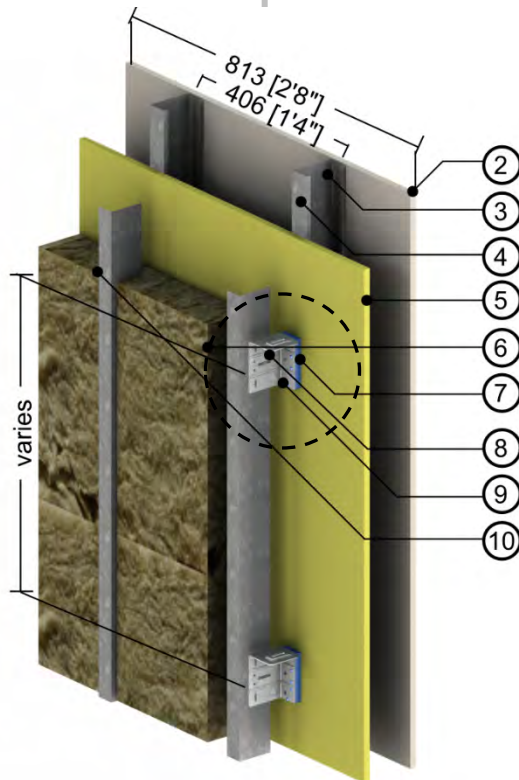

ISO Clip Detail

ID	Component	Thickness Inches (mm)	Conductivity Btu·in / ft ² ·hr·°F (W/m K)	Nominal Resistance hr·ft ² ·°F/Btu (m ² K/W)	Density lb/ft ³ (kg/m ³)	Specific Heat Btu/lb·°F (J/kg K)
1	Interior Film ¹	-	-	R-0.7 (0.12 RSI)	-	-
2	Gypsum Board	1/2" (13)	1.1 (0.16)	R-0.5 (0.08 RSI)	50 (800)	0.26 (1090)
3	Air in Stud Cavity	3 5/8" (92)	-	R-0.9 (0.16 RSI)	0.075 (1.2)	0.24 (1000)
4	3 5/8" x 1 5/8" Steel Studs	18 Gauge	430 (62)	-	489 (7830)	0.12 (500)
5	Exterior Sheathing	1/2" (13)	1.1 (0.16)	R-0.5 (0.08 RSI)	50 (800)	0.26 (1090)
6	Exterior Mineral Wool Insulation	4" to 6" (102 to 152)	0.24 (0.034)	R-16.8 to R-25.2 (2.96 RSI to 4.44 RSI)	4 (64)	0.20 (850)
7	ISO Clip - HDPE Isolator	1/2" (12.7)	3.1 (0.45)	-	-	-
8	ISO Clip - Galvanized Metal	14 Gauge	430 (62)	-	489 (7830)	0.12 (500)
9	#14 Steel Fasteners	1/4" (6) Ø	347 (50)	-	489 (7830)	0.12 (500)
10	Vertical Sub-girt	16 Gauge	430 (62)	-	489 (7830)	0.12 (500)
11	Generic Cladding with 1/2" (13mm) vented air space is incorporated into exterior heat transfer coefficient					
12	Exterior Film ¹	-	-	R-0.7 (0.12 RSI)	-	-

¹ Value selected from table 1, p. 26.1 of 2009 ASHRAE Handbook – Fundamentals depending on surface orientation

Detail 5.1.42 Exterior Insulated 3 5/8" x 1 5/8" Steel Stud (16" o.c.) Wall Assembly with Thermally Broken ISO Clip System Supporting Horizontal Sub-girts – Clear Wall

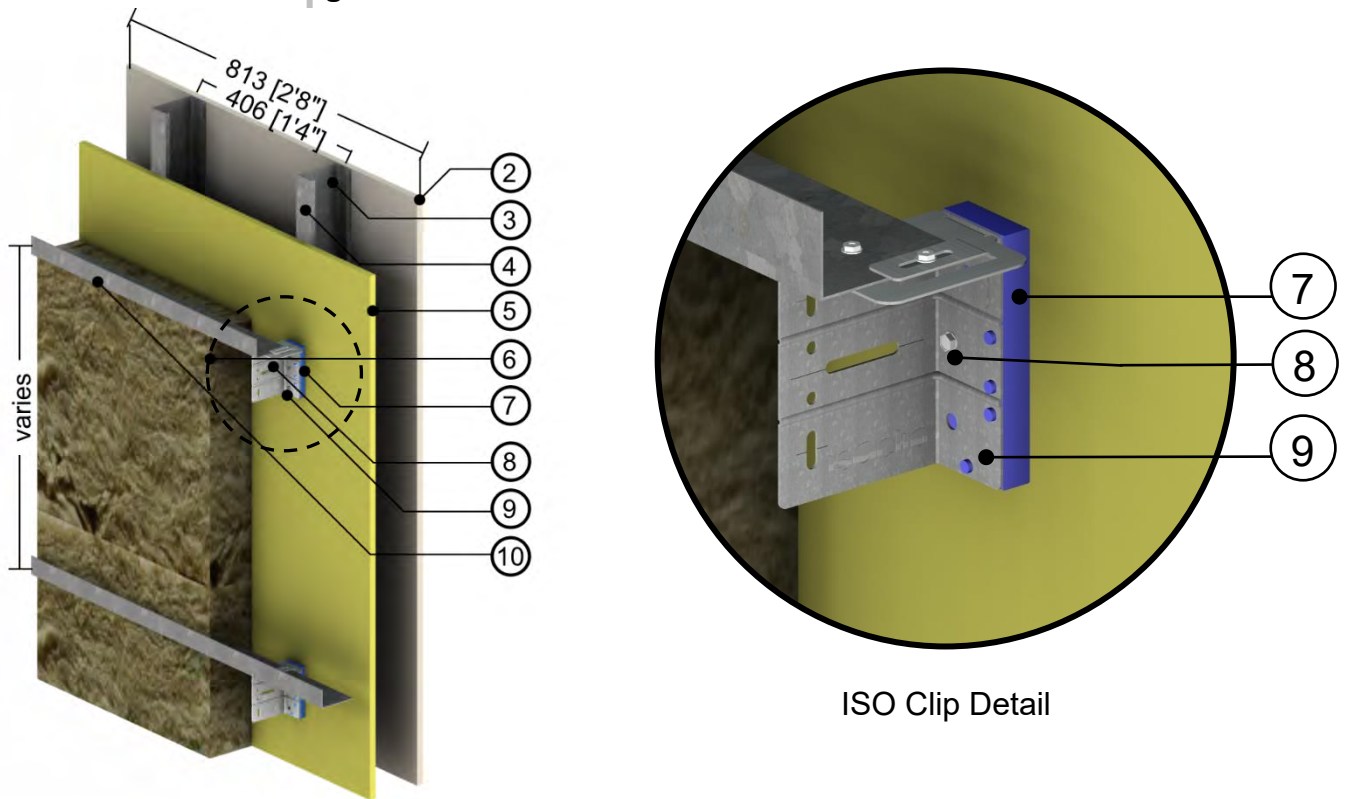

ID	Component	Thickness Inches (mm)	Conductivity Btu-in / ft ² -hr-°F (W/m K)	Nominal Resistance hr-ft ² -°F/Btu (m ² K/W)	Density lb/ft ³ (kg/m ³)	Specific Heat Btu/lb-°F (J/kg K)
1	Interior Film ¹	-	-	R-0.7 (0.12 RSI)	-	-
2	Gypsum Board	1/2" (13)	1.1 (0.16)	R-0.5 (0.08 RSI)	50 (800)	0.26 (1090)
3	Air in Stud Cavity	3 5/8" (92)	-	R-0.9 (0.16 RSI)	0.075 (1.2)	0.24 (1000)
4	3 5/8" x 1 5/8" Steel Studs	18 Gauge	430 (62)	-	489 (7830)	0.12 (500)
5	Exterior Sheathing	1/2" (13)	1.1 (0.16)	R-0.5 (0.08 RSI)	50 (800)	0.26 (1090)
6	Exterior Mineral Wool Insulation	4" to 6" (102 to 152)	0.24 (0.034)	R-16.8 to R-25.2 (2.96 RSI to 4.44 RSI)	4 (64)	0.20 (850)
7	ISO Clip - HDPE Isolator	1/2" (12.7)	3.1 (0.45)	-	-	-
8	#14 Steel Fasteners	1/4" (6) Ø	347 (50)	-	489 (7830)	0.12 (500)
9	ISO Clip - Galvanized Metal	14 Gauge	430 (62)	-	489 (7830)	0.12 (500)
10	Horizontal Sub-girt	16 Gauge	430 (62)	-	489 (7830)	0.12 (500)
11	Generic Cladding with 1/2" (13mm) vented air space is incorporated into exterior heat transfer coefficient					
12	Exterior Film ¹	-	-	R-0.7 (0.12 RSI)	-	-

¹ Value selected from table 1, p. 26.1 of 2009 ASHRAE Handbook – Fundamentals depending on surface orientation

Detail 5.1.43

Exterior and Interior Insulated 3 5/8" x 1 5/8" Steel Stud (16" o.c.) Wall Assembly with Thermally Broken ISO Clip System Supporting Vertical Sub-girts and R-12 Batt Insulation in Stud Cavity – Clear Wall

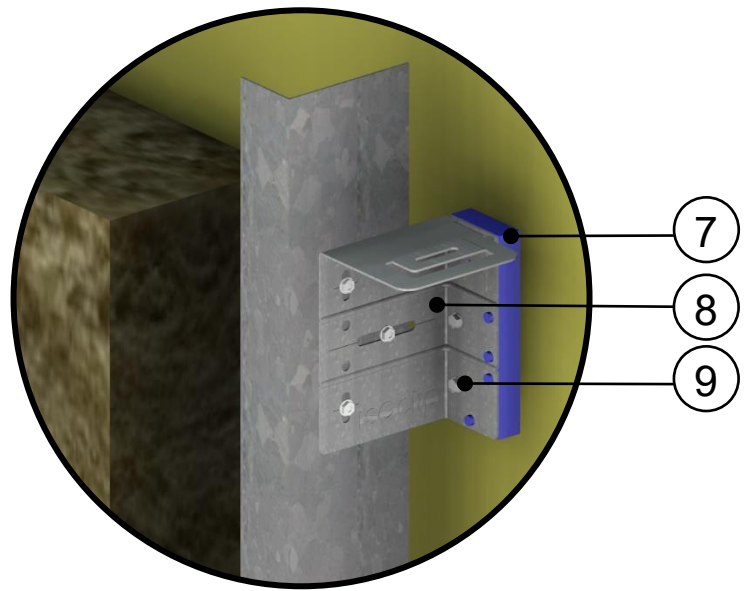
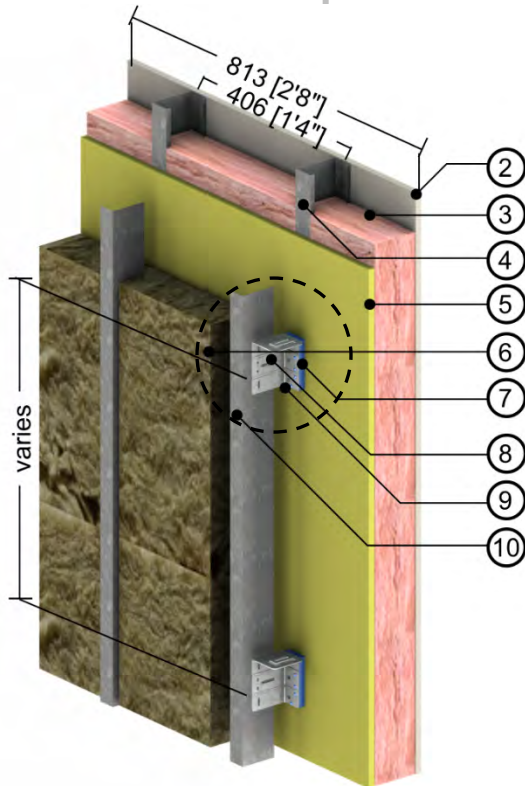

ISO Clip Detail

ID	Component	Thickness Inches (mm)	Conductivity Btu-in / ft ² ·hr·°F (W/m K)	Nominal Resistance hr·ft ² ·°F/Btu (m ² K/W)	Density lb/ft ³ (kg/m ³)	Specific Heat Btu/lb·°F (J/kg K)
1	Interior Film ¹	-	-	R-0.7 (0.12 RSI)	-	-
2	Gypsum Board	1/2" (13)	1.1 (0.16)	R-0.5 (0.08 RSI)	50 (800)	0.26 (1090)
3	Fiberglass Batt Insulation	3 5/8" (92)	0.31 (0.044)	R-12 (2.2 RSI)	0.9 (14)	0.17 (710)
4	3 5/8" x 1 5/8" Steel Studs	18 Gauge	430 (62)	-	489 (7830)	0.12 (500)
5	Exterior Sheathing	1/2" (13)	1.1 (0.16)	R-0.5 (0.08 RSI)	50 (800)	0.26 (1090)
6	Exterior Mineral Wool Insulation	4" to 6" (102 to 152)	0.24 (0.034)	R-16.8 to R-25.2 (2.96 RSI to 4.44 RSI)	4 (64)	0.20 (850)
7	ISO Clip - HDPE Isolator	1/2" (12.7)	3.1 (0.45)	-	-	-
8	ISO Clip - Galvanized Metal	14 Gauge	430 (62)	-	489 (7830)	0.12 (500)
9	#14 Steel Fasteners	1/4" (6) Ø	347 (50)	-	489 (7830)	0.12 (500)
10	Vertical Sub-girt	16 Gauge	430 (62)	-	489 (7830)	0.12 (500)
11	Generic Cladding with 1/2" (13mm) vented air space is incorporated into exterior heat transfer coefficient					
12	Exterior Film ¹	-	-	R-0.7 (0.12 RSI)	-	-

¹ Value selected from table 1, p. 26.1 of 2009 ASHRAE Handbook – Fundamentals depending on surface orientation

Detail 5.1.44

Exterior and Interior Insulated 3 5/8" x 1 5/8" Steel Stud (16" o.c.) Wall Assembly with Thermally Broken ISO Clip System Supporting Horizontal Sub-girts and R-12 Batt Insulation in Stud Cavity – Clear Wall

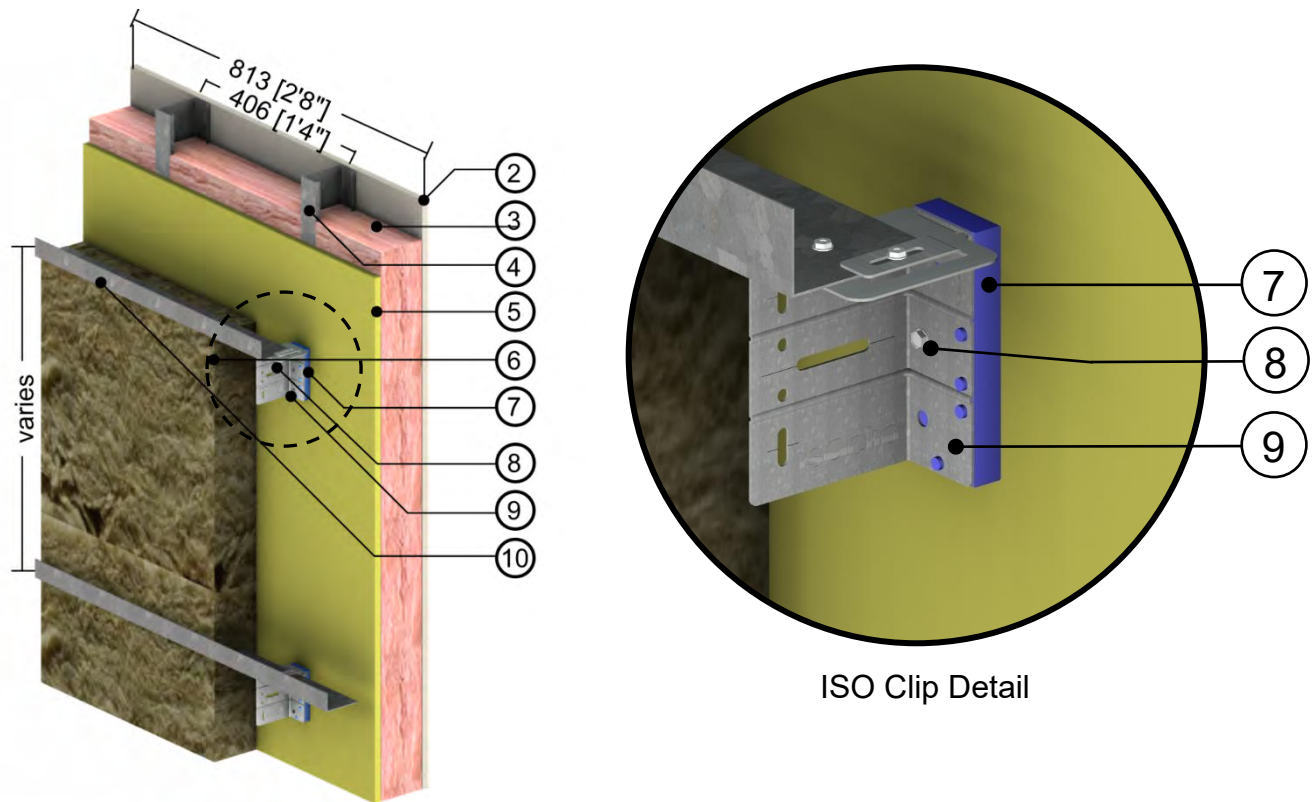

ID	Component	Thickness Inches (mm)	Conductivity Btu-in / ft ² ·hr·°F (W/m K)	Nominal Resistance hr·ft ² ·°F/Btu (m ² K/W)	Density lb/ft ³ (kg/m ³)	Specific Heat Btu/lb·°F (J/kg K)
1	Interior Film ¹	-	-	R-0.7 (0.12 RSI)	-	-
2	Gypsum Board	1/2" (13)	1.1 (0.16)	R-0.5 (0.08 RSI)	50 (800)	0.26 (1090)
3	Fiberglass Batt Insulation	3 5/8" (92)	0.31 (0.044)	R-12 (2.2 RSI)	0.9 (14)	0.17 (710)
4	3 5/8" x 1 5/8" Steel Studs	18 Gauge	430 (62)	-	489 (7830)	0.12 (500)
5	Exterior Sheathing	1/2" (13)	1.1 (0.16)	R-0.5 (0.08 RSI)	50 (800)	0.26 (1090)
6	Exterior Mineral Wool Insulation	4" to 6" (102 to 152)	0.24 (0.034)	R-16.8 to R-25.2 (2.96 RSI to 4.44 RSI)	4 (64)	0.20 (850)
7	ISO Clip - HDPE Isolator	1/2" (12.7)	3.1 (0.45)	-	-	-
8	#14 Steel Fasteners	1/4" (6) Ø	347 (50)	-	489 (7830)	0.12 (500)
9	ISO Clip - Galvanized Metal	14 Gauge	430 (62)	-	489 (7830)	0.12 (500)
10	Horizontal Sub-girt	16 Gauge	430 (62)	-	489 (7830)	0.12 (500)
11	Generic Cladding with 1/2" (13mm) vented air space is incorporated into exterior heat transfer coefficient					
12	Exterior Film ¹	-	-	R-0.7 (0.12 RSI)	-	-

¹ Value selected from table 1, p. 26.1 of 2009 ASHRAE Handbook – Fundamentals depending on surface orientation

Detail 5.1.45 Exterior Insulated 3 5/8" x 1 5/8" Steel Stud (16" o.c.) Wall Assembly with Thermally Broken ISO Clip System (16" o.c.) Supporting Horizontal and Vertical Sub-girts – Clear Wall

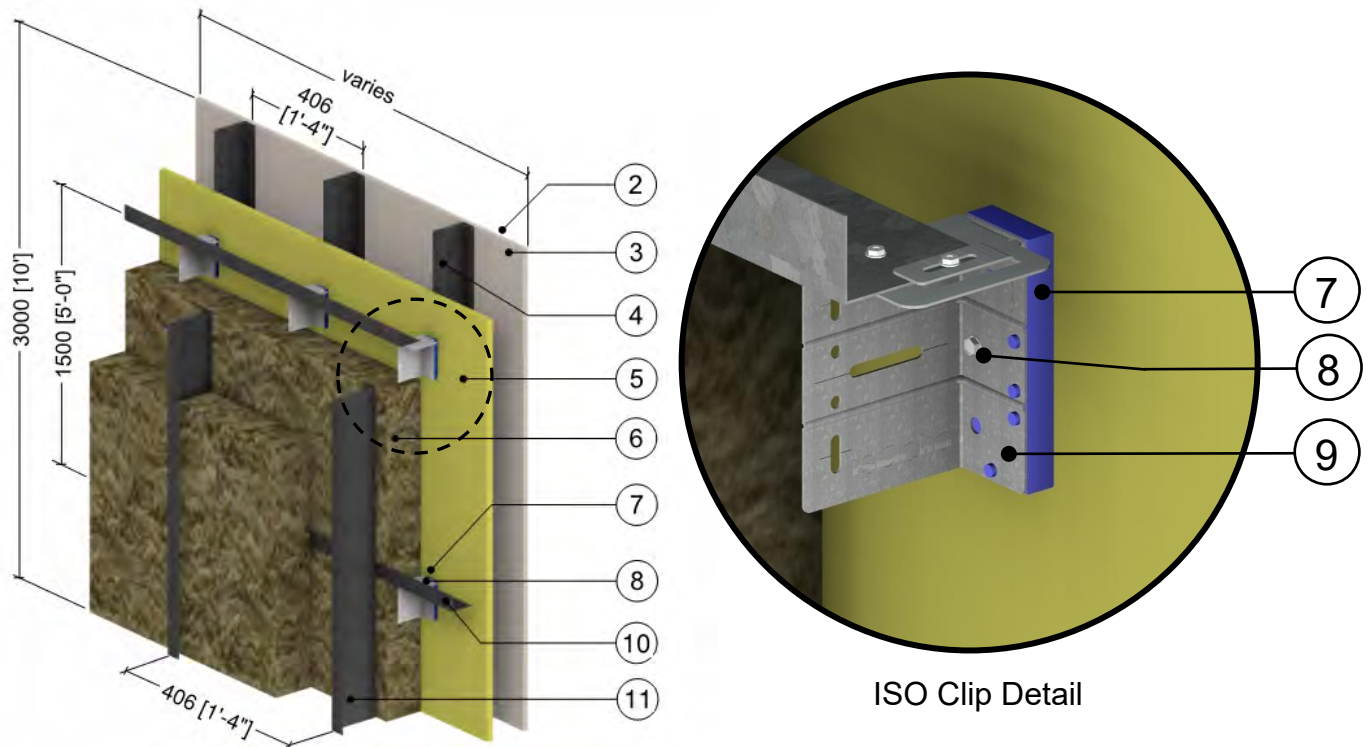

ID	Component	Thickness Inches (mm)	Conductivity Btu-in / ft ² -hr-°F (W/m K)	Nominal Resistance hr-ft ² -°F/Btu (m ² K/W)	Density lb/ft ³ (kg/m ³)	Specific Heat Btu/lb-°F (J/kg K)
1	Interior Film ¹	-	-	R-0.7 (0.12 RSI)	-	-
2	Gypsum Board	1/2" (13)	1.1 (0.16)	R-0.5 (0.08 RSI)	50 (800)	0.26 (1090)
3	Air in Stud Cavity	3 5/8" (92)	-	R-0.9 (0.16 RSI)	0.075 (1.2)	0.24 (1000)
4	3 5/8" x 1 5/8" Steel Studs	18 Gauge	430 (62)	-	489 (7830)	0.12 (500)
5	Exterior Sheathing	1/2" (13)	1.1 (0.16)	R-0.5 (0.08 RSI)	50 (800)	0.26 (1090)
6	Exterior Mineral Wool Insulation	4" to 6" (102 to 152)	0.24 (0.034)	R-16.8 to R-25.2 (2.96 RSI to 4.44 RSI)	4 (64)	0.20 (850)
7	ISO Clip - HDPE Isolator	1/2" (12.7)	3.1 (0.45)	-	-	-
8	Fasteners	1/4" (6) ∅	347 (50)	-	489 (7830)	0.12 (500)
9	ISO Clip - Galvanized Metal	14 Gauge	430 (62)	-	489 (7830)	0.12 (500)
10	Horizontal Sub-girt	16 Gauge	430 (62)	-	489 (7830)	0.12 (500)
11	Vertical Sub-girt	16 Gauge	430 (62)	-	489 (7830)	0.12 (500)
11	Generic Cladding with 1/2" (13mm) vented air space is incorporated into exterior heat transfer coefficient					
12	Exterior Film ¹	-	-	R-0.7 (0.12 RSI)	-	-

¹ Value selected from table 1, p. 26.1 of 2009 ASHRAE Handbook – Fundamentals depending on surface orientation

Detail 5.1.46

Exterior Insulated 3 5/8" x 1 5/8" Steel Stud (16" o.c.) Wall Assembly with Thermally Broken ISO Clip System (32" o.c.) Supporting Horizontal and Vertical Sub-girts – Clear Wall

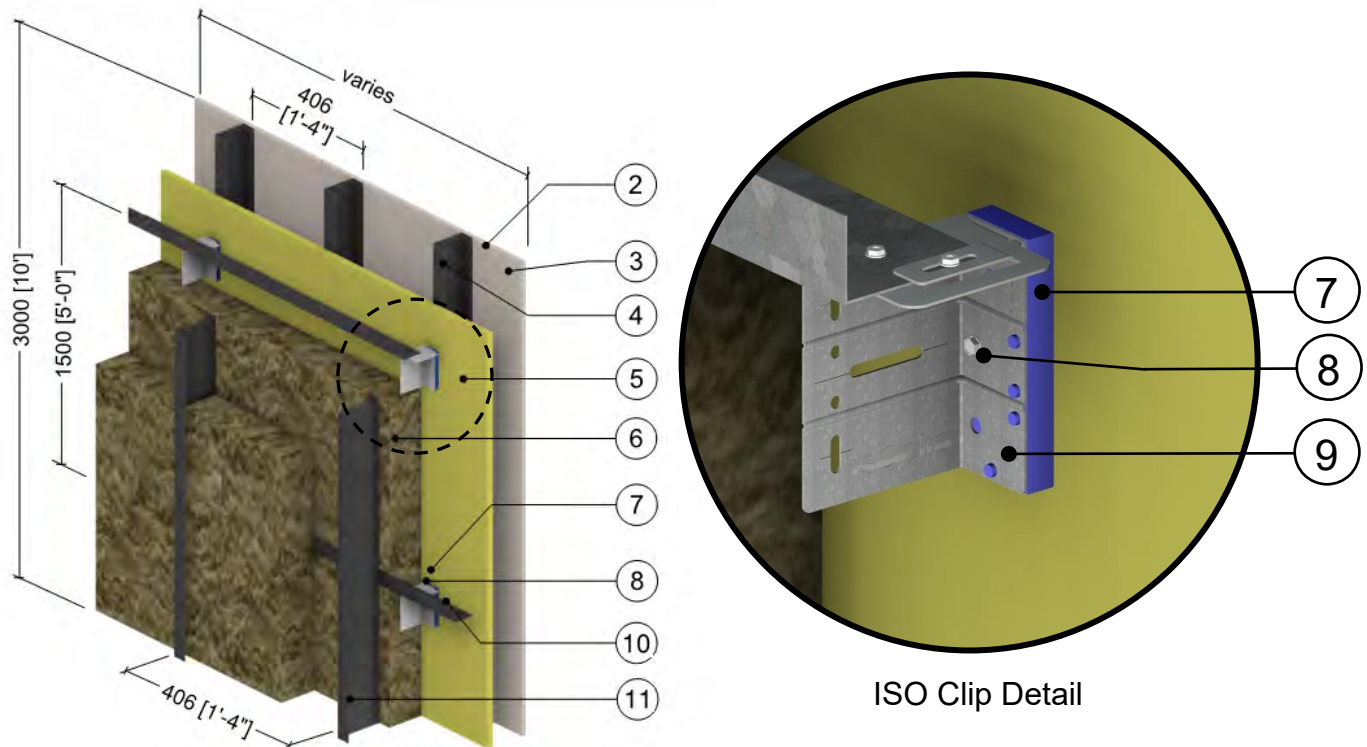

ID	Component	Thickness Inches (mm)	Conductivity Btu-in / ft ² -hr-°F (W/m K)	Nominal Resistance hr-ft ² -°F/Btu (m ² K/W)	Density lb/ft ³ (kg/m ³)	Specific Heat Btu/lb-°F (J/kg K)
1	Interior Film ¹	-	-	R-0.7 (0.12 RSI)	-	-
2	Gypsum Board	1/2" (13)	1.1 (0.16)	R-0.5 (0.08 RSI)	50 (800)	0.26 (1090)
3	Air in Stud Cavity	3 5/8" (92)	-	R-0.9 (0.16 RSI)	0.075 (1.2)	0.24 (1000)
4	3 5/8" x 1 5/8" Steel Studs	18 Gauge	430 (62)	-	489 (7830)	0.12 (500)
5	Exterior Sheathing	1/2" (13)	1.1 (0.16)	R-0.5 (0.08 RSI)	50 (800)	0.26 (1090)
6	Exterior Mineral Wool Insulation	4" to 6" (102 to 152)	0.24 (0.034)	R-16.8 to R-25.2 (2.96 RSI to 4.44 RSI)	4 (64)	0.20 (850)
7	ISO Clip - HDPE Isolator	1/2" (12.7)	3.1 (0.45)	-	-	-
8	Fasteners	1/4" (6) ∅	347 (50)	-	489 (7830)	0.12 (500)
9	ISO Clip - Galvanized Metal	14 Gauge	430 (62)	-	489 (7830)	0.12 (500)
10	Horizontal Sub-girt	16 Gauge	430 (62)	-	489 (7830)	0.12 (500)
11	Vertical Sub-girt	16 Gauge	430 (62)	-	489 (7830)	0.12 (500)
11	Generic Cladding with 1/2" (13mm) vented air space is incorporated into exterior heat transfer coefficient					
12	Exterior Film ¹	-	-	R-0.7 (0.12 RSI)	-	-

¹ Value selected from table 1, p. 26.1 of 2009 ASHRAE Handbook – Fundamentals depending on surface orientation

Detail 5.1.47

Exterior Insulated 3 5/8" x 1 5/8" Steel Stud (16" o.c.) Wall Assembly with Nvelope – NV1 Clip System Supporting Cladding – Clear Wall

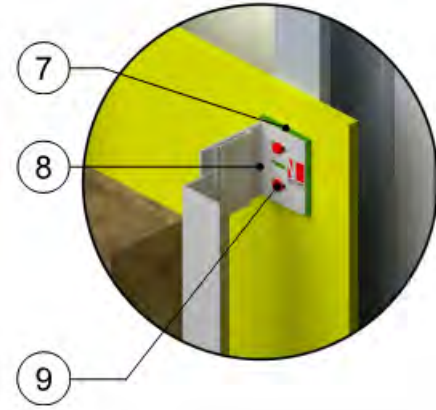
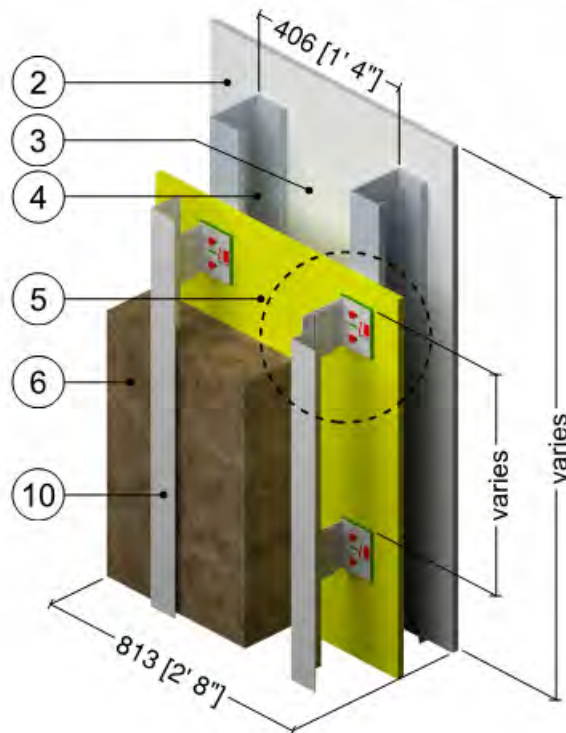

NV1 Clip Detail

ID	Component	Thickness Inches (mm)	Conductivity Btu-in / ft ² ·hr·°F (W/m K)	Nominal Resistance hr·ft ² ·°F/Btu (m ² K/W)	Density lb/ft ³ (kg/m ³)	Specific Heat Btu/lb·°F (J/kg K)
1	Interior Films ¹	-	-	R-0.7 (0.12 RSI)	-	-
2	Gypsum Board	1/2" (13)	1.1 (0.16)	R-0.5 (0.08 RSI)	50 (800)	0.26 (1090)
3	Air in Stud Cavity	3 5/8" (92)	-	R-0.9 (0.16 RSI)	0.075 (1.2)	0.24 (1000)
4	3 5/8" x 1 5/8" Steel Studs	18 Gauge	430 (62)	-	489 (7830)	0.12 (500)
5	Exterior Sheathing	1/2" (13)	1.1 (0.16)	R-0.5 (0.08 RSI)	50 (800)	0.26 (1090)
6	Exterior Mineral Wool Insulation	3" to 6" (76 to 152)	0.24 (0.034)	R-12.6 to R-25.2 (2.22 RSI to 4.44 RSI)	4 (64)	0.20 (850)
7	NV1 Clip Isolator	0.2" (5)	0.82 (0.117)	-	87 (1400)	0.20 (840)
8	NV1 Clip Extrusion – Aluminum 6005A alloy	Varies	1340 (193)	-	169 (2700)	0.22 (900)
9	#14 Stainless Steel Fasteners	1/4" (6) Ø	118 (17)	-	500 (8000)	0.12 (500)
10	Vertical Sub-girt	0.09" (2.2)	1340 (193)	-	169 (2700)	0.22 (900)
11	Generic Cladding with 1/2" (13mm) vented air space is incorporated into exterior heat transfer coefficient					
12	Exterior Film ¹	-	-	R-0.7 (0.12 RSI)	-	-

¹ Value selected from table 1, p. 26.1 of 2009 ASHRAE Handbook – Fundamentals depending on surface orientation

Detail 5.1.48

Exterior and Interior Insulated 3 5/8" x 1 5/8" Steel Stud (16" o.c.) Wall Assembly with Nvelope – NV1 Clip System Supporting Cladding and R-12 Batt Insulation in Stud Cavity – Clear Wall

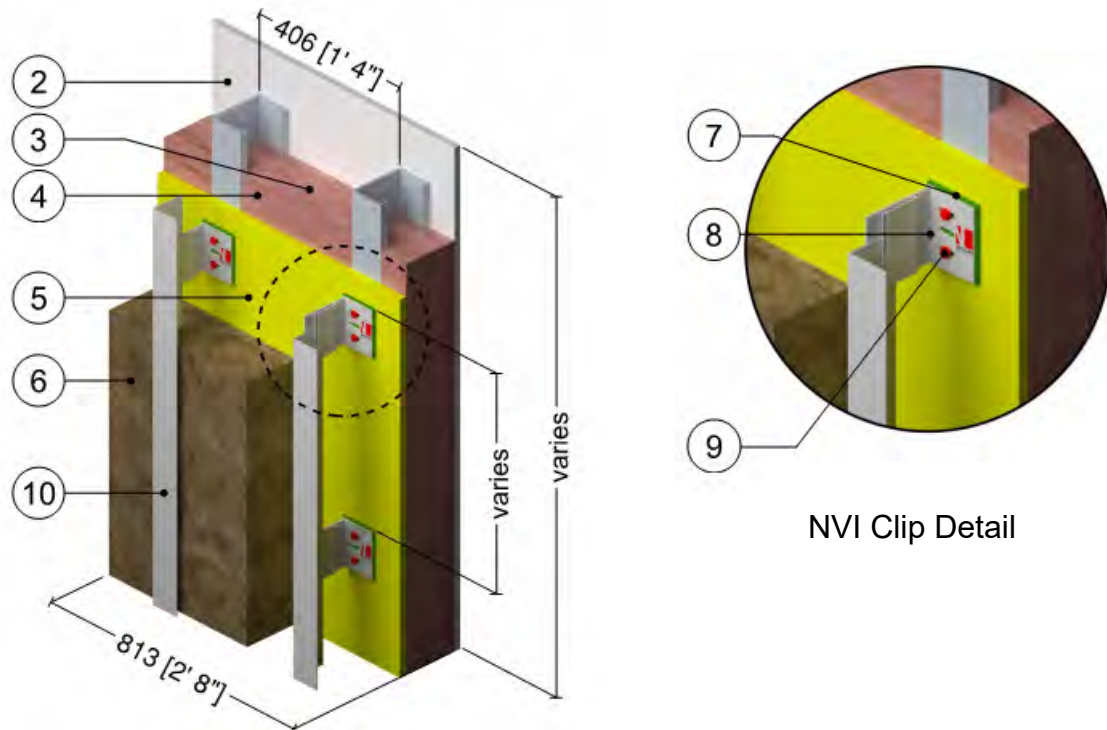

ID	Component	Thickness Inches (mm)	Conductivity Btu-in / ft ² -hr-°F (W/m K)	Nominal Resistance hr-ft ² -°F/Btu (m ² K/W)	Density lb/ft ³ (kg/m ³)	Specific Heat Btu/lb-°F (J/kg K)
1	Interior Films ¹	-	-	R-0.7 (0.12 RSI)	-	-
2	Gypsum Board	1/2" (13)	1.1 (0.16)	R-0.5 (0.08 RSI)	50 (800)	0.26 (1090)
3	Fiberglass Batt Insulation	3 5/8" (92)	0.31 (0.044)	R-12 (2.2 RSI)	0.9 (14)	0.17 (710)
4	3 5/8" x 1 5/8" Steel Studs	18 Gauge	430 (62)	-	489 (7830)	0.12 (500)
5	Exterior Sheathing	1/2" (13)	1.1 (0.16)	R-0.5 (0.08 RSI)	50 (800)	0.26 (1090)
6	Exterior Mineral Wool Insulation	2" to 6" (50 152)	0.24 (0.034)	R-8.4 to R-25.2 (1.48 RSI to 4.44 RSI)	4 (64)	0.20 (850)
7	NV1 Clip Isolator	0.2" (5)	0.82 (0.117)	-	87 (1400)	0.20 (840)
8	NV1 Clip Extrusion – Aluminum 6005A alloy	Varies	1340 (193)	-	169 (2700)	0.22 (900)
9	#14 Stainless Steel Fasteners	1/4" (6) Ø	118 (17)	-	500 (8000)	0.12 (500)
10	Vertical Sub-girt	0.09" (2.2)	1340 (193)	-	169 (2700)	0.22 (900)
11	Generic Cladding with 1/2" (13mm) vented air space is incorporated into exterior heat transfer coefficient					
12	Exterior Film ¹	-	-	R-0.7 (0.12 RSI)	-	-

¹ Value selected from table 1, p. 26.1 of 2009 ASHRAE Handbook – Fundamentals depending on surface orientation

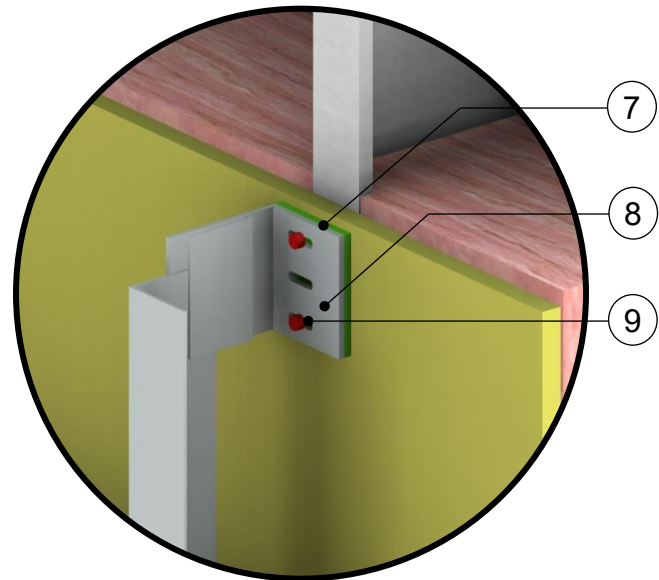
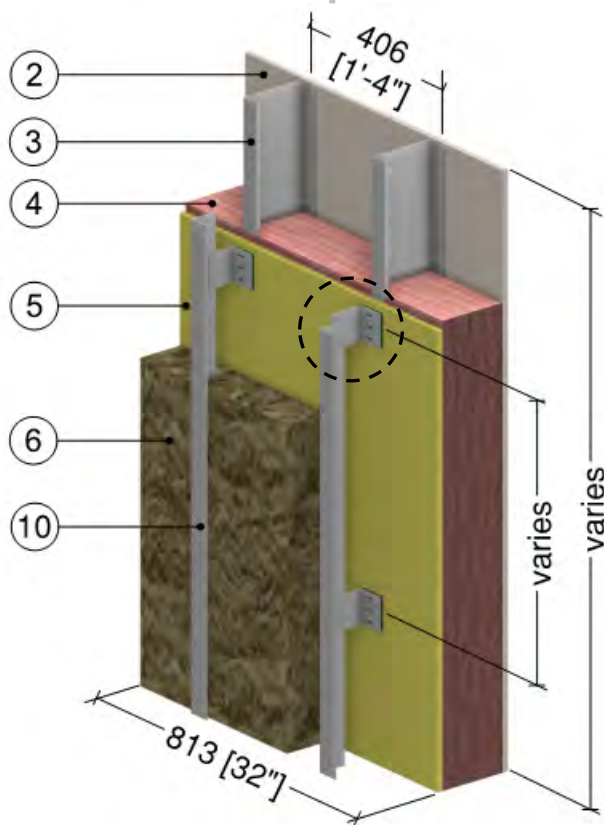
Detail 5.1.49**Exterior and Interior Insulated 6" x 1 5/8" Steel Stud (16" o.c.) Wall Assembly with Nvelope – NV1 Clip System Supporting Cladding and R-19 Batt Insulation in Stud Cavity – Clear Wall**

Nvelope NV1 Clip Detail

ID	Component	Thickness Inches (mm)	Conductivity Btu·in / ft ² ·hr·°F (W/m K)	Nominal Resistance hr·ft ² ·°F/Btu (m ² K/W)	Density lb/ft ³ (kg/m ³)	Specific Heat Btu/lb·°F (J/kg K)
1	Interior Film ¹	-	-	R-0.7 (0.12 RSI)	-	-
2	Gypsum Board	1/2" (13)	1.1 (0.16)	R-0.5 (0.08 RSI)	50 (800)	0.26 (1090)
3	6" x 1 5/8" Steel Studs	18 Gauge	430 (62)	-	489 (7830)	0.12 (500)
4	Fiberglass Batt Insulation	6" (152)	0.31 (0.045)	R-19 (3.35 RSI)	0.9 (14)	0.17 (710)
5	Exterior Sheathing	1/2" (13)	1.1 (0.16)	R-0.5 (0.08 RSI)	50 (800)	0.26 (1090)
6	Exterior Mineral Wool Insulation	1.5" to 4" (38 to 102)	0.24 (0.034)	R-6.3 to R-16.8 (1.11 RSI to 2.96 RSI)	4 (64)	0.20 (850)
7	Nvelope Clip Isolator	0.2" (5)	0.82 (0.117)	-	-	-
8	Nvelope Clip Extrusion – Aluminum 6005A alloy	Varies	1340 (193)	-	169 (2700)	0.22 (900)
9	#14 Stainless Steel Fastener	1/4" (6) ∅	118 (17)	-	500 (8000)	0.13 (530)
10	Vertical Aluminum Sub-girt	0.09" (2.2)	1340 (193)	-	169 (2700)	0.22 (900)
11	Generic Cladding with 1" (25mm) vented air space is incorporated into exterior heat transfer coefficient					
12	Exterior Film ¹	-	-	R-0.7 (0.12 RSI)	-	-

¹ Value selected from table 1, p. 26.1 of 2009 ASHRAE Handbook – Fundamentals depending on surface orientation

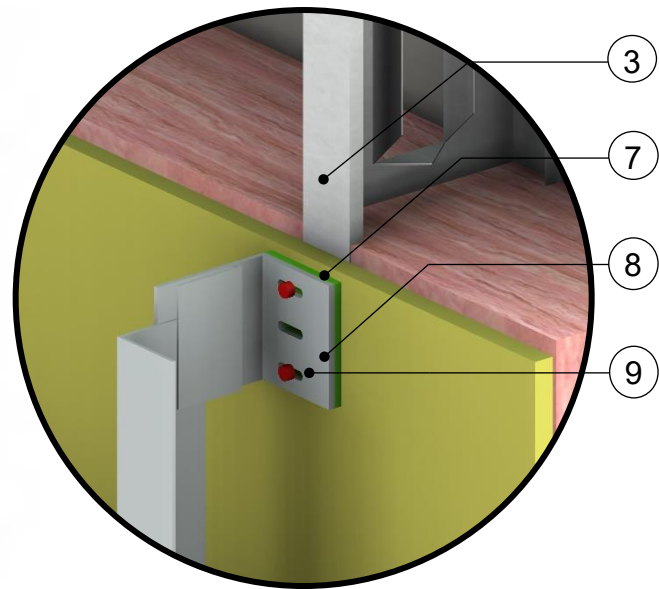
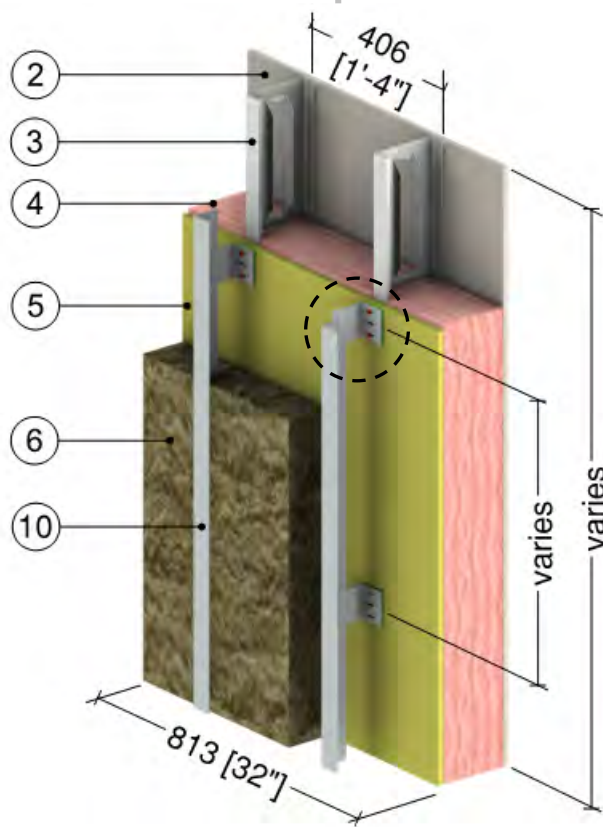
Detail 5.1.50**Exterior and Interior Insulated 6" x 1 5/8" Slotted Steel R-Stud (16" o.c.) Wall Assembly with Nvelope – NV1 Clip System Supporting Cladding and R-19 Batt Insulation in Stud Cavity – Clear Wall**

Nvelope NV1 Clip Detail

ID	Component	Thickness Inches (mm)	Conductivity Btu-in / ft ² ·hr·°F (W/m K)	Nominal Resistance hr·ft ² ·°F/Btu (m ² K/W)	Density lb/ft ³ (kg/m ³)	Specific Heat Btu/lb·°F (J/kg K)
1	Interior Film ¹	-	-	R-0.7 (0.12 RSI)	-	-
2	Gypsum Board	1/2" (13)	1.1 (0.16)	R-0.5 (0.08 RSI)	50 (800)	0.26 (1090)
3	6" x 1 5/8" Slotted Steel R-Studs	18 Gauge	430 (62)	-	489 (7830)	0.12 (500)
4	Fiberglass Batt Insulation	6" (152)	0.31 (0.045)	R-19 (3.35 RSI)	0.9 (14)	0.17 (710)
5	Exterior Sheathing	1/2" (13)	1.1 (0.16)	R-0.5 (0.08 RSI)	50 (800)	0.26 (1090)
6	Exterior Mineral Wool Insulation	1.5" to 4" (38 to 102)	0.24 (0.034)	R-6.3 to R-16.8 (1.11 RSI to 2.96 RSI)	4 (64)	0.20 (850)
7	Nvelope Clip Isolator	0.2" (5)	0.82 (0.117)	-	-	-
8	Nvelope Clip Extrusion – Aluminum 6005A alloy	Varies	1340 (193)	-	169 (2700)	0.22 (900)
9	#14 Stainless Steel Fastener	1/4" (6) ∅	118 (17)	-	500 (8000)	0.13 (530)
10	Vertical Aluminum Sub-girt	0.09" (2.2)	1340 (193)	-	169 (2700)	0.22 (900)
11	Generic Cladding with 1" (25mm) vented air space is incorporated into exterior heat transfer coefficient					
12	Exterior Film ¹	-	-	R-0.7 (0.12 RSI)	-	-

¹ Value selected from table 1, p. 26.1 of 2009 ASHRAE Handbook – Fundamentals depending on surface orientation

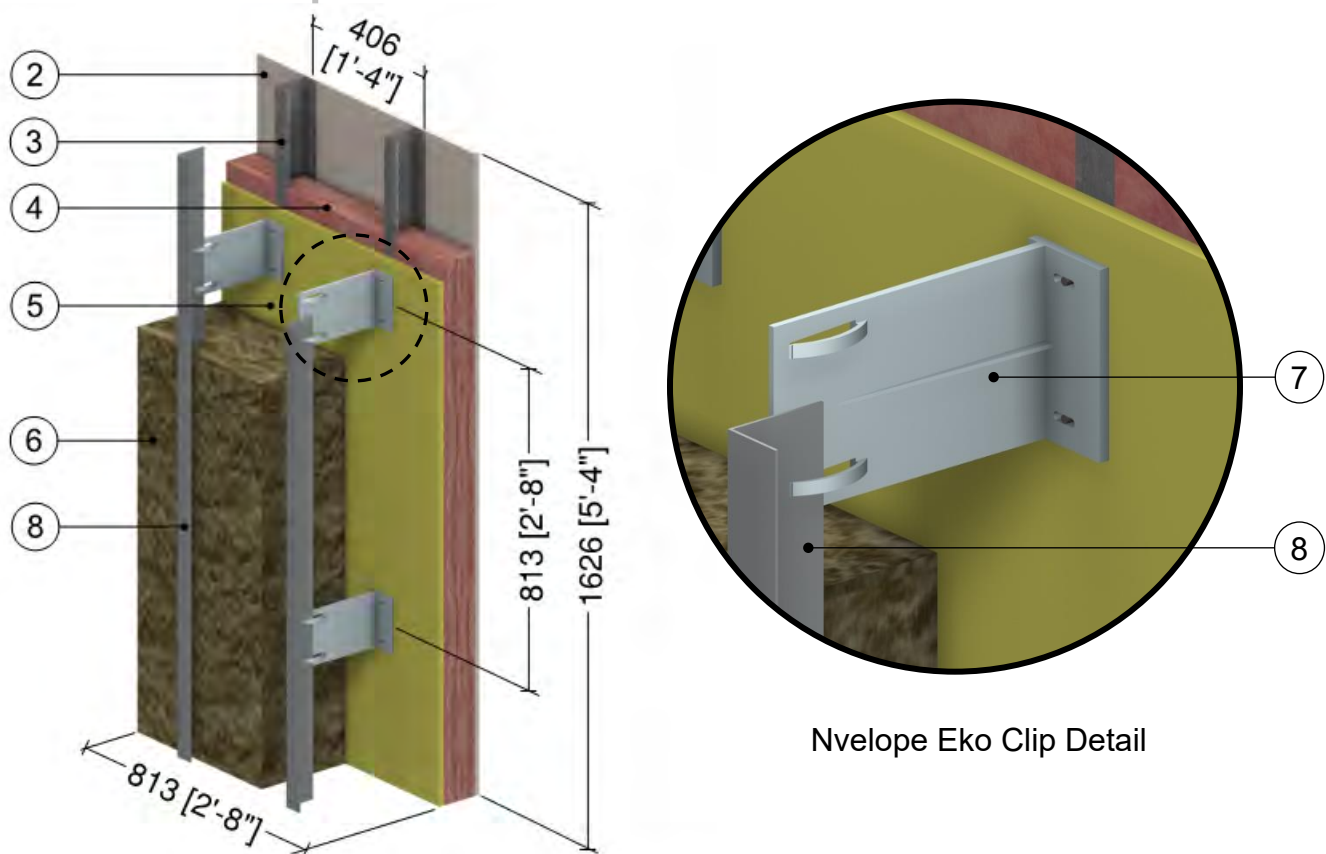
Detail 5.1.51**Exterior and Interior Insulated 3 5/8" x 1 5/8" Steel Stud (16" o.c.) Wall Assembly with Nvelope – Eko Thermobacket Clip System Supporting Cladding and R-13 Batt Insulation in Stud Cavity – Clear Wall**

Nvelope Eko Clip Detail

ID	Component	Thickness Inches (mm)	Conductivity Btu-in / ft ² ·hr·°F (W/m K)	Nominal Resistance hr·ft ² ·°F/Btu (m ² K/W)	Density lb/ft ³ (kg/m ³)	Specific Heat Btu/lb·°F (J/kg K)
1	Interior Film ¹	-	-	R-0.7 (0.12 RSI)	-	-
2	Gypsum Board	1/2" (13)	1.1 (0.16)	R-0.5 (0.08 RSI)	50 (800)	0.26 (1090)
3	3 5/8" x 1 5/8" Steel Studs	18 Gauge	430 (62)	-	489 (7830)	0.12 (500)
4	Fiberglass Batt Insulation	3 5/8" (92)	0.28 (0.040)	R-13 (2.29 RSI)	0.9 (14)	0.17 (710)
5	Exterior Sheathing	1/2" (13)	1.1 (0.16)	R-0.5 (0.08 RSI)	50 (800)	0.26 (1090)
6	Exterior Mineral Wool Insulation	10" (254)	0.24 (0.034)	R-42.0 (7.40 RSI)	4 (64)	0.20 (850)
7	Nvelope Eko Thermobacket (Polymer Composite)	-	4.86 (0.70)	-	-	-
8	Vertical Aluminum Sub-girt	0.09" (2.2)	1340 (193)	-	169 (2700)	0.22 (900)
9	Generic Cladding with 1" (25mm) vented air space is incorporated into exterior heat transfer coefficient					
10	Exterior Film ¹	-	-	R-0.7 (0.12 RSI)	-	-

¹ Value selected from table 1, p. 26.1 of 2009 ASHRAE Handbook – Fundamentals depending on surface orientation

Detail 5.1.52

Exterior and Interior Insulated 3 5/8" x 1 5/8" Steel Stud (16" o.c.) Wall Assembly with Nvelope – Eko Thermobacket and NV1 Clip System Supporting Cladding and R-13 Batt Insulation in Stud Cavity – Clear Wall

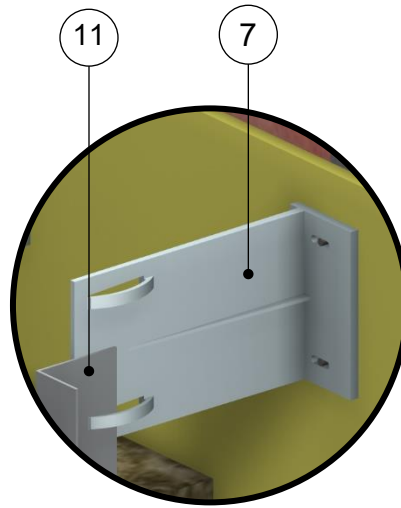
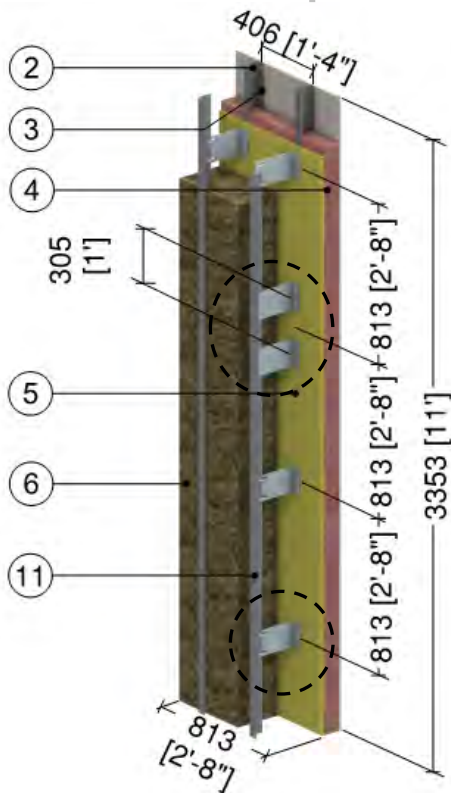

Nvelope Eko Thermobacket Clip Detail

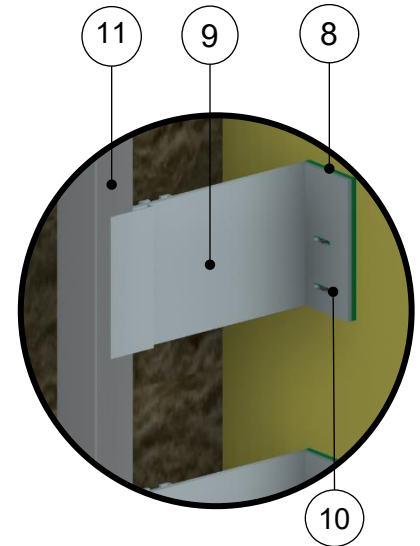

Nvelope NV1 Clip Detail

ID	Component	Thickness Inches (mm)	Conductivity Btu-in / ft ² -hr-°F (W/m K)	Nominal Resistance hr-ft ² -°F/Btu (m ² K/W)	Density lb/ft ³ (kg/m ³)	Specific Heat Btu/lb-°F (J/kg K)
1	Interior Film ¹	-	-	R-0.7 (0.12 RSI)	-	-
2	Gypsum Board	1/2" (13)	1.1 (0.16)	R-0.5 (0.08 RSI)	50 (800)	0.26 (1090)
3	3 5/8" x 1 5/8" Steel Studs	18 Gauge	430 (62)	-	489 (7830)	0.12 (500)
4	Fiberglass Batt Insulation	3 5/8" (92)	0.28 (0.040)	R-13 (2.29 RSI)	0.9 (14)	0.17 (710)
5	Exterior Sheathing	1/2" (13)	1.1 (0.16)	R-0.5 (0.08 RSI)	50 (800)	0.26 (1090)
6	Exterior Mineral Wool Insulation	10" (254)	0.24 (0.034)	R-42.0 (7.40 RSI)	4 (64)	0.20 (850)
7	Nvelope Eko Thermobacket (Polymer Composite)	-	4.86 (0.70)	-	-	-
8	Nvelope Clip Isolator	0.2" (5)	0.82 (0.117)	-	-	-
9	Nvelope Clip Extrusion – Aluminum 6005A alloy	Varies	1340 (193)	-	169 (2700)	0.22 (900)
10	#14 Stainless Steel Fastener	1/4" (6) ∅	118 (17)	-	-	-
11	Vertical Aluminum Sub-girt	0.09" (2.2)	1340 (193)	-	169 (2700)	0.22 (900)
12	Generic Cladding with 1" (25mm) vented air space is incorporated into exterior heat transfer coefficient					
13	Exterior Film ¹	-	-	R-0.2 (0.03 RSI)	-	-

¹ Value selected from table 1, p. 26.1 of 2009 ASHRAE Handbook – Fundamentals depending on surface orientation

Detail 5.1.53

Exterior Insulated 3 5/8" x 1 5/8" Steel Stud (16" O.C.) Wall Assembly with Cascadia Clip Fiberglass Thermal Spacers – Clear Wall

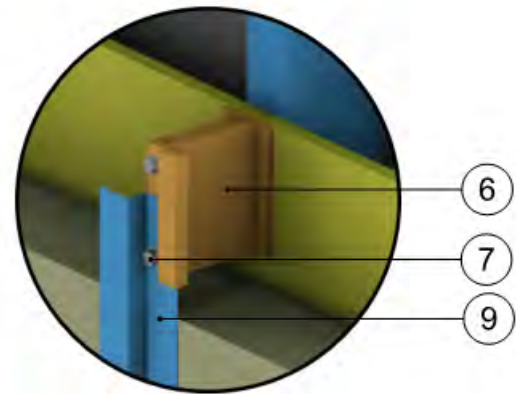
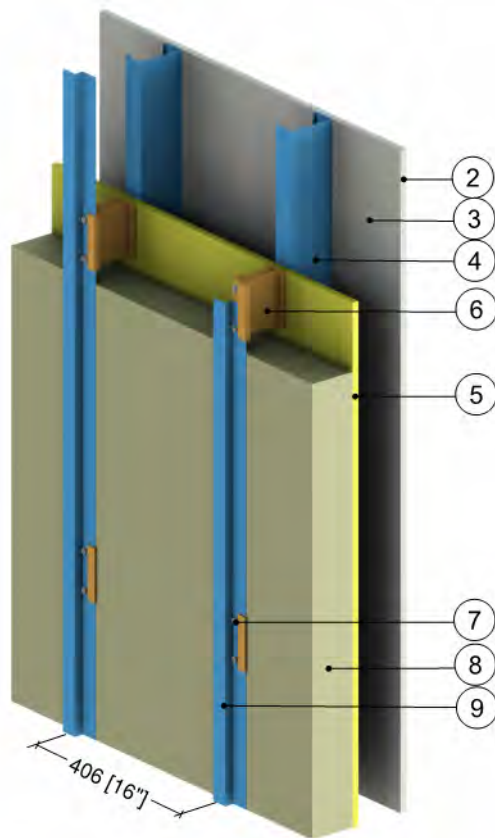

Cascadia Clip
Fiberglass Thermal
Spacer Detail

ID	Component	Thickness Inches (mm)	Conductivity Btu-in / ft ² -hr-°F (W/m K)	Nominal Resistance hr-ft ² -°F/Btu (m ² K/W)	Density lb/ft ³ (kg/m ³)	Specific Heat Btu/lb-°F (J/kg K)
1	Interior Films ¹	-	-	R-0.7 (0.12 RSI)	-	-
2	Gypsum Board	1/2" (13)	1.1 (0.16)	R-0.5 (0.09 RSI)	50 (800)	0.26 (1090)
3	Air in Stud Cavity	3 5/8" (92)	-	R-0.9 (0.16 RSI)	0.075 (1.2)	0.24 (1000)
4	3 5/8" x 1 5/8" Steel Studs	18 Gauge	430 (62)	-	489 (7830)	0.12 (500)
5	Exterior Sheathing	1/2" (13)	1.1 (0.16)	R-0.5 (0.09 RSI)	50 (800)	0.26 (1090)
6	Cascadia Clip	Varies	2.07 (0.299)	-	-	-
7	#14 Stainless Steel Fasteners	1/4" (6) Ø	118 (17)	-	500 (8000)	0.12 (500)
8	Exterior Mineral Wool Insulation	Varies	-	R-8.4 to R-33.6 (1.48 to 5.92 RSI)	4 (64)	0.20 (850)
9	Vertical Z-girts	18 Gauge	430 (62)	-	489 (7830)	0.12 (500)
10	Cladding with 1/2" (13mm) vented airspace incorporated into exterior heat transfer coefficient					
11	Exterior Film ¹	-	-	R-0.7 (0.12 RSI)	-	-

¹ Value selected from table 1, p. 26.1 of 2009 ASHRAE Handbook – Fundamentals depending on surface orientation

Detail 5.1.54

Exterior and Interior Insulated 6" x 1 5/8" Steel Stud (16" o.c. and 24" o.c.) Wall Assembly with Vertical Clips (24" o.c. and 36" o.c.) Supporting Cladding and Owens Corning R-20 Batt Insulation in Stud Cavity – Clear Wall

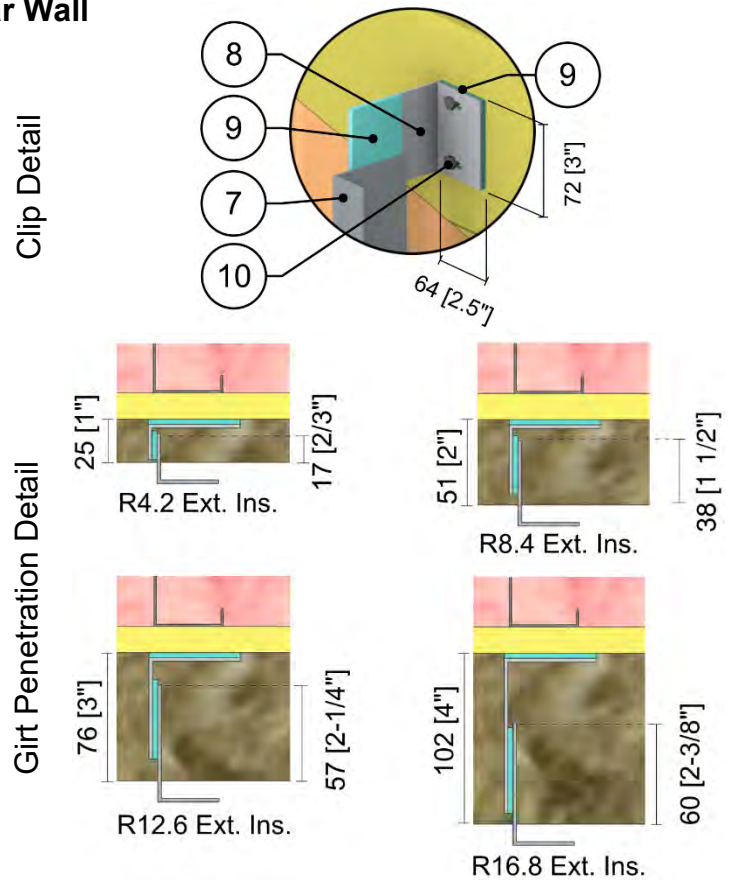
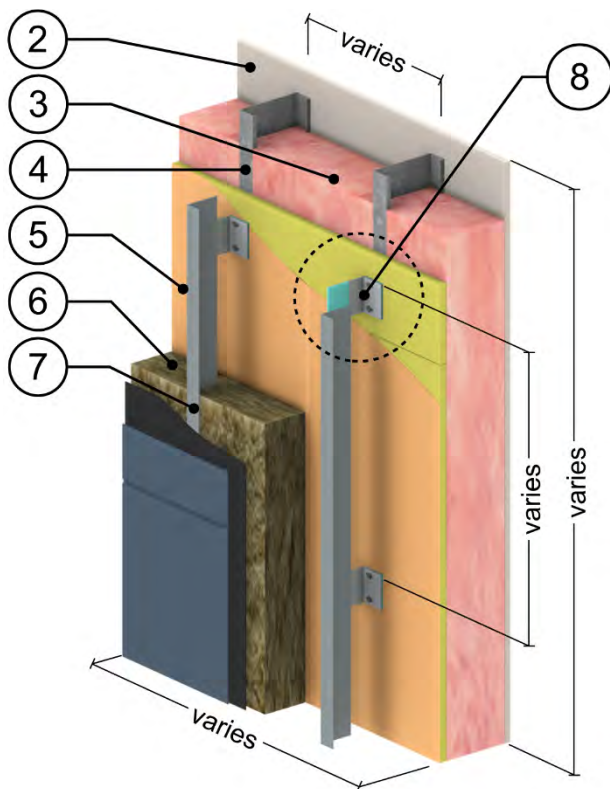

ID	Component	Thickness Inches (mm)	Conductivity Btu-in / ft ² ·hr·°F (W/m K)	Nominal Resistance hr·ft ² ·°F/Btu (m ² K/W)	Density lb/ft ³ (kg/m ³)	Specific Heat Btu/lb·°F (J/kg K)
1	Interior Films ¹	-	-	R-0.7 (0.12 RSI)	-	-
2	Gypsum Board	1/2" (13)	1.1 (0.16)	R-0.5 (0.08 RSI)	50 (800)	0.26 (1090)
3	Ecotouch Pink Fiberglass Batt	6" (152)	0.30 (0.043)	R-20 (3.5 RSI)	0.55 (8.8)	0.17 (710)
4	6" x 1 5/8" Steel Studs	18 Gauge	430 (62)	-	489 (7830)	0.12 (500)
5	Exterior Sheathing	5/8" (16)	1.1 (0.16)	R-0.6 (0.10 RSI)	50 (800)	0.26 (1090)
6	Thermafiber RainBarrier 45 Mineral Wool Semi Rigid Insulation	Varies	0.24 (0.034)	R-4.2 to R-16.8 (0.75 to 3.0 RSI)	4.5 (72)	0.20 (850)
7	Vertical Aluminum L-girt	0.09" (2.2)	1340 (193)	-	169 (2700)	0.22 (900)
8	Aluminum Clip	0.09" (2.2)	1110 (160)	-	171 (2739)	0.22 (900)
9	HDPE Isolator	1/8" (3)	3.5 (0.5)	-	59 (950)	0.48 (2000)
10	#14 Stainless Steel Fasteners	1/4" (6) Ø	118 (17)	-	500 (8000)	0.12 (500)
11	Cladding with 1/2" vented airspace incorporated into exterior heat transfer coefficient					
12	Exterior Film ¹	-	-	R-0.7 (0.12 RSI)	-	-

¹ Value selected from table 1, p. 26.1 of 2009 ASHRAE Handbook – Fundamentals depending on surface orientation

Detail 5.1.55

Exterior and Interior Insulated 6" x 1 5/8" Steel Stud (16" o.c. and 24" o.c.) Wall Assembly with Vertical Clips (24" o.c. and 36" o.c.) Supporting Cladding and Owens Corning R-22.5 Batt Insulation in Stud Cavity– Clear Wall

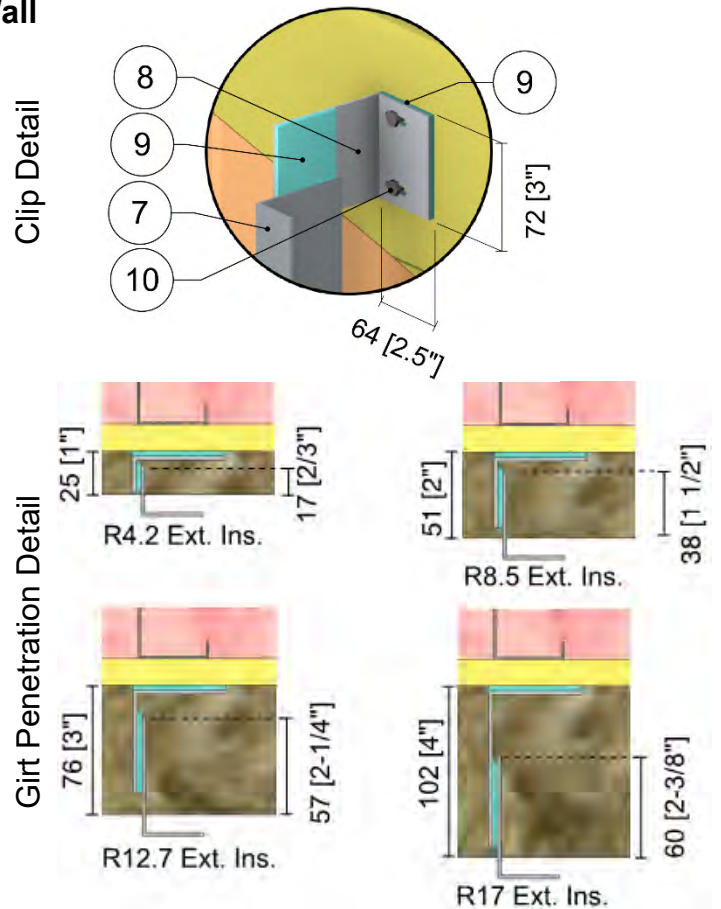
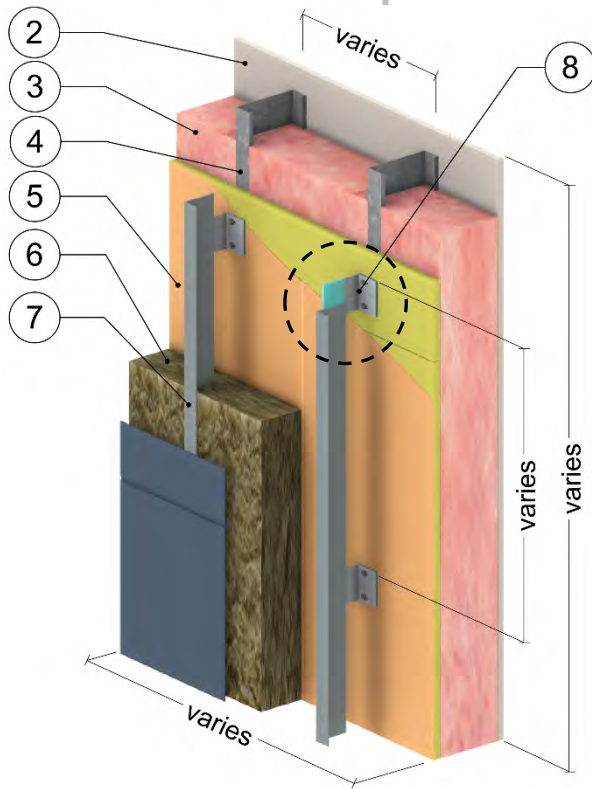

ID	Component	Thickness Inches (mm)	Conductivity Btu·in / ft ² ·hr·°F (W/m K)	Nominal Resistance hr·ft ² ·°F/Btu (m ² K/W)	Density lb/ft ³ (kg/m ³)	Specific Heat Btu/lb·°F (J/kg K)
1	Interior Films ¹	-	-	R-0.7 (0.12 RSI)	-	-
2	Gypsum Board	1/2" (13)	1.1 (0.16)	R-0.5 (0.09 RSI)	50 (800)	0.26 (1090)
3	Ecotouch Pink Fiberglass Batt	6" (152)	0.26 (0.038)	R-22.5 (4.0 RSI)	0.99 (15.9)	0.17 (710)
4	6" x 1 5/8" Steel Studs	18 Gauge	430 (62)	-	489 (7830)	0.12 (500)
5	Exterior Sheathing	5/8" (16)	1.1 (0.16)	R-0.6 (0.10 RSI)	50 (800)	0.26 (1090)
6	Thermafiber RainBarrier 45 Mineral Wool Semi Rigid Insulation	Varies	0.24 (0.034)	R-4.2 to R-16.8 (0.75 to 2.96 RSI)	4.5 (72)	0.20 (850)
7	Vertical Aluminum L-girt	0.09" (2.2)	1110 (160)	-	171 (2739)	0.21 (900)
8	Aluminum Clip	0.09" (2.2)	1110 (160)	-	171 (2739)	0.21 (900)
9	HDPE Isolator	1/8" (3)	3.5 (0.5)	-	59 (950)	0.48 (2000)
10	Stainless Steel Fastener	1/4" (6) ∅	118 (17)	-	500 (8000)	0.12 (500)
11	Cladding with 1/2" vented airspace incorporated into exterior heat transfer coefficient					
12	Exterior Film ¹	-	-	R-0.7 (0.12 RSI)	-	-

¹ Value selected from table 1, p. 26.1 of 2009 ASHRAE Handbook – Fundamentals depending on surface orientation

Detail 5.1.56

Exterior and Interior Insulated 6" x 1/8" Steel Stud (16" o.c. and 24" o.c.) Wall Assembly with Vertical Clips (24" o.c. and 36" o.c.) Supporting Cladding and Owens Corning R-24 Batt Insulation in Stud Cavity– Clear Wall

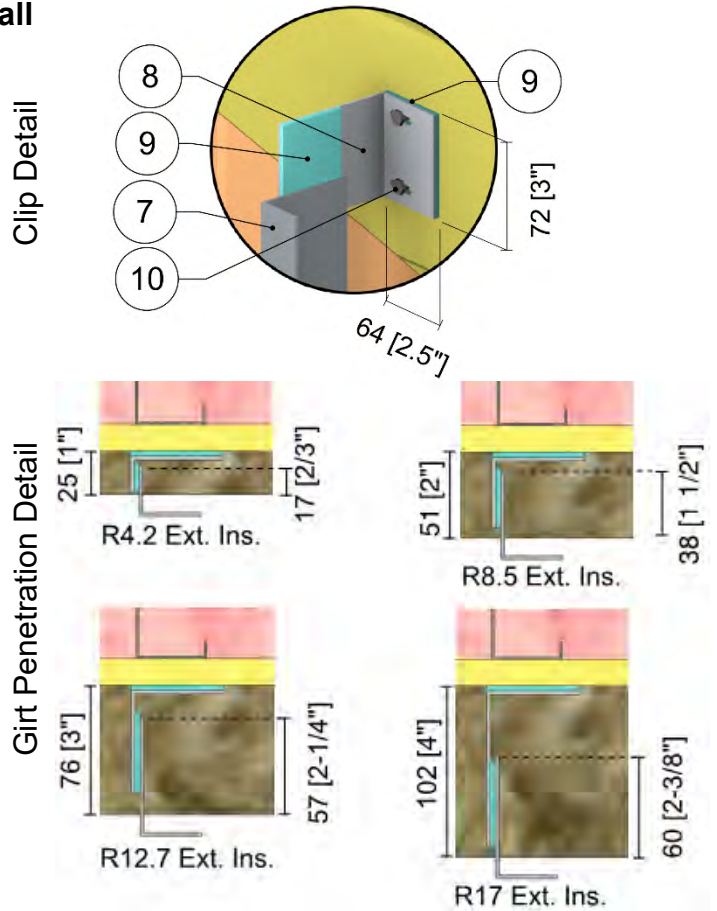
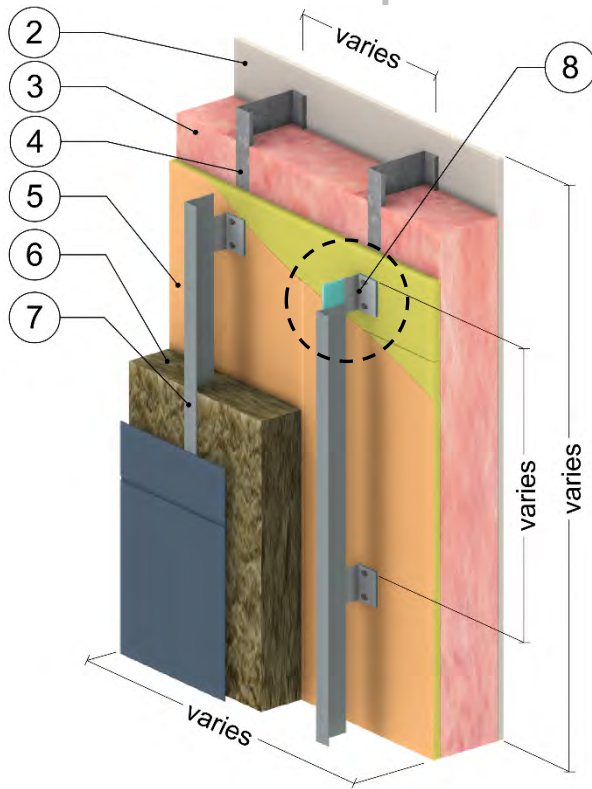

ID	Component	Thickness Inches (mm)	Conductivity Btu-in / ft ² ·hr·°F (W/m K)	Nominal Resistance hr·ft ² ·°F/Btu (m ² K/W)	Density lb/ft ³ (kg/m ³)	Specific Heat Btu/lb·°F (J/kg K)
1	Interior Films ¹	-	-	R-0.7 (0.12 RSI)	-	-
2	Gypsum Board	1/2" (13)	1.1 (0.16)	R-0.5 (0.09 RSI)	50 (800)	0.26 (1090)
3	Ecotouch Pink Fiberglass Batt	6" (152)	0.25 (0.036)	R-24 (4.2 RSI)	1.42 (22.7)	0.17 (710)
4	6" x 1 5/8" Steel Studs	18 Gauge	430 (62)	-	489 (7830)	0.12 (500)
5	Exterior Sheathing	5/8" (16)	1.1 (0.16)	R-0.6 (0.10 RSI)	50 (800)	0.26 (1090)
6	Thermafiber RainBarrier 45 Mineral Wool Semi Rigid Insulating Sheathing	Varies	0.24 (0.034)	R-4.2 (0.75) to R-16.8 (2.96 RSI)	4.5 (72)	0.20 (850)
7	Vertical Aluminum L-girt	0.09" (2.2)	1110 (160)	-	171 (2739)	0.21 (900)
8	Aluminum Clip	0.09" (2.2)	1110 (160)	-	171 (2739)	0.21 (900)
9	HDPE Isolator	1/8" (3)	3.5 (0.5)	-	59 (950)	0.48 (2000)
10	#14 Stainless Steel Fasteners	1/4" (6) Ø	118 (17)	-	500 (8000)	0.12 (500)
11	Cladding with 1/2" vented airspace incorporated into exterior heat transfer coefficient					
12	Exterior Film ¹	-	-	R-0.7 (0.12 RSI)	-	-

¹ Value selected from table 1, p. 26.1 of 2009 ASHRAE Handbook – Fundamentals depending on surface orientation

Detail 5.1.57

Exterior Insulated 6" x 1 5/8" Steel Stud (16" o.c. and 24" o.c.) Wall Assembly with Vertical Clips (24" o.c. and 36" o.c.) Supporting Cladding – Clear Wall

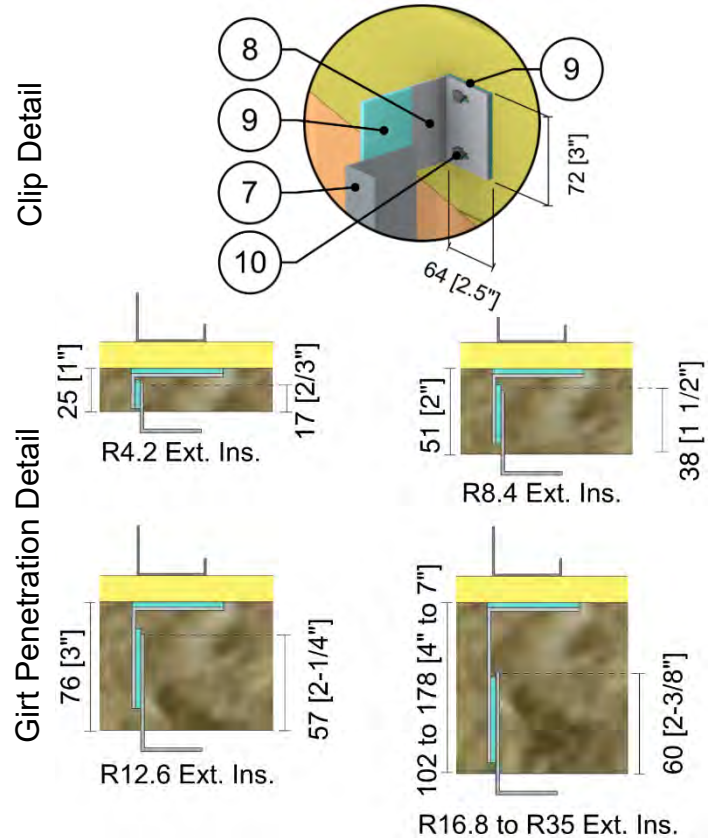
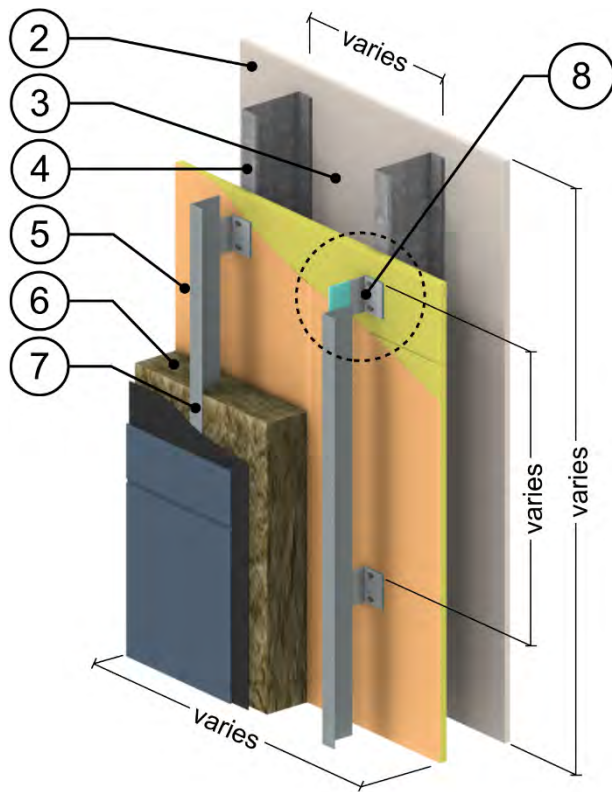

ID	Component	Thickness Inches (mm)	Conductivity Btu-in / ft ² -hr-°F (W/m K)	Nominal Resistance hr-ft ² -°F/Btu (m ² K/W)	Density lb/ft ³ (kg/m ³)	Specific Heat Btu/lb-°F (J/kg K)
1	Interior Films ¹	-	-	R-0.7 (0.12 RSI)	-	-
2	Gypsum Board	1/2" (13)	1.1 (0.16)	R-0.5 (0.08 RSI)	50 (800)	0.26 (1090)
3	Air in Stud Cavity	6" (152)	-	R-0.9 (0.16 RSI)	0.075 (1.2)	0.24 (1000)
4	6" x 1 5/8" Steel Studs	18 Gauge	430 (62)	-	489 (7830)	0.12 (500)
5	Exterior Sheathing	5/8" (16)	1.1 (0.16)	R-0.6 (0.10 RSI)	50 (800)	0.26 (1090)
6	Exterior Insulation	Varies	0.24 (0.034)	R-4.2 to R-29.4 (0.74 to 5.18 RSI)	4 (64)	0.20 (850)
7	Vertical Aluminum L-girt – Aluminum 6005A alloy	0.09" (2.2)	1340 (193)	-	169 (2700)	0.22 (900)
8	Aluminum Bracket	0.09" (2.2)	1110 (160)	-	171 (2739)	0.22 (900)
9	HDPE Isolator	1/8" (3)	3.5 (0.5)	-	59 (950)	0.48 (2000)
10	#14 Stainless Steel Fasteners	1/4" (6) Ø	118 (17)	-	500 (8000)	0.12 (500)
11	Cladding with 1/2" vented airspace incorporated into exterior heat transfer coefficient					
12	Exterior Film ¹	-	-	R-0.7 (0.12 RSI)	-	-

¹ Value selected from table 1, p. 26.1 of 2009 ASHRAE Handbook – Fundamentals depending on surface orientation

Detail 5.1.58

Owens Corning Exterior Insulated 6" x 1 5/8" Steel Stud (16" o.c.) Wall Assembly with Thermally Isolated Vertical Brackets and Rail System (24" o.c.) Supporting Metal Cladding – Clear Wall

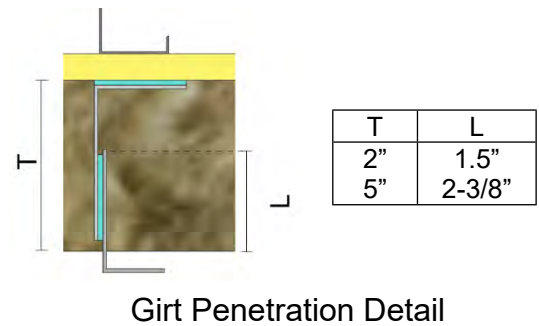
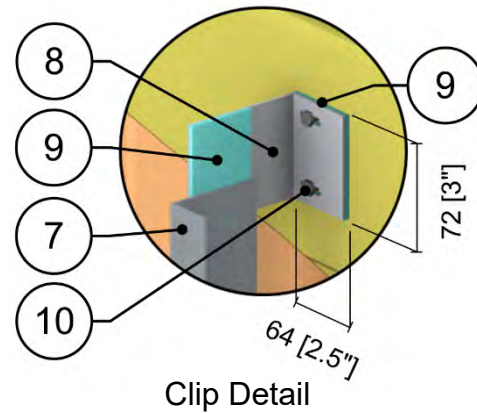
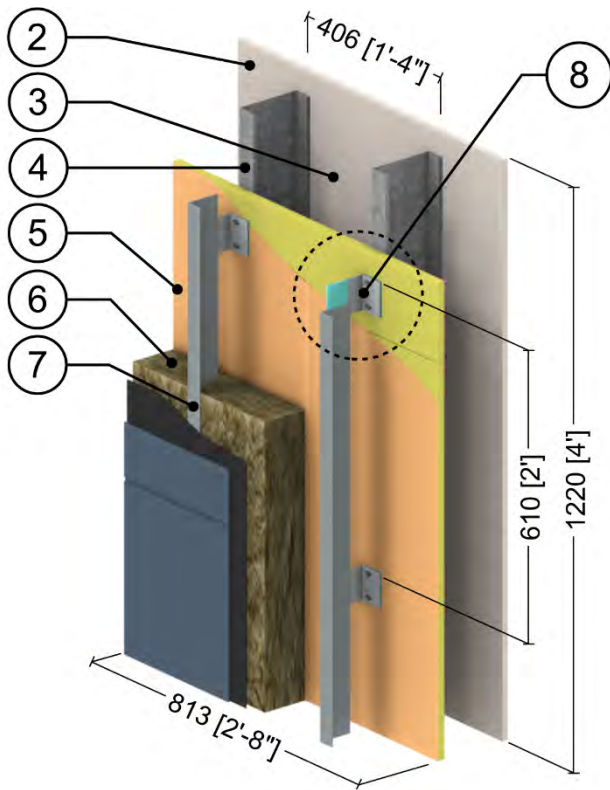

ID	Component	Thickness Inches (mm)	Conductivity Btu·in / ft ² ·hr·°F (W/m K)	Nominal Resistance hr·ft ² ·°F/Btu (m ² K/W)	Density lb/ft ³ (kg/m ³)	Specific Heat Btu/lb·°F (J/kg K)
1	Interior Films ¹	-	-	R-0.7 (0.12 RSI)	-	-
2	Gypsum Board	1/2" (13)	1.1 (0.16)	R-0.5 (0.09 RSI)	50 (800)	0.26 (1090)
3	Air in Stud Cavity	6" (152)	-	R-0.9 (0.16 RSI)	0.075 (1.2)	0.24 (1000)
4	6" x 1 5/8" Steel Studs	18 Gauge	430 (62)	-	489 (7830)	0.12 (500)
5	Exterior Sheathing	5/8" (16)	1.1 (0.16)	R-0.6 (0.10 RSI)	50 (800)	0.26 (1090)
6	Thermafiber RainBarrier 45 Mineral Wool Semi Rigid Insulation	Varies	0.24 (0.034)	R-8.4 to R-21.0 (1.11 to 3.70 RSI)	4.5 (72)	0.20 (850)
7	Vertical Aluminum L-girt	0.09" (2.2)	1110 (160)	-	171 (2739)	0.22 (900)
8	Aluminum Bracket	0.09" (2.2)	1110 (160)	-	171 (2739)	0.22 (900)
9	HDPE Isolator	1/8" (3)	3.5 (0.5)	-	59 (950)	0.48 (2000)
10	#14 Stainless Steel Fastener	1/4" (6) Ø	118 (17)	-	500 (8000)	0.12 (500)
11	Cladding with 1/2" vented airspace incorporated into exterior heat transfer coefficient					
12	Exterior Film ¹	-	-	R-0.7 (0.12 RSI)	-	-

¹ Value selected from table 1, p. 26.1 of 2009 ASHRAE Handbook – Fundamentals depending on surface orientation

Detail 5.1.59

Exterior and Interior Insulated 6" x 1 5/8" Steel Stud (16" o.c. and 24" o.c.) Wall Assembly with Vertical Clips (24" o.c. and 36" o.c.) Supporting Cladding and R-20 Batt Insulation in Stud Cavity – Clear Wall

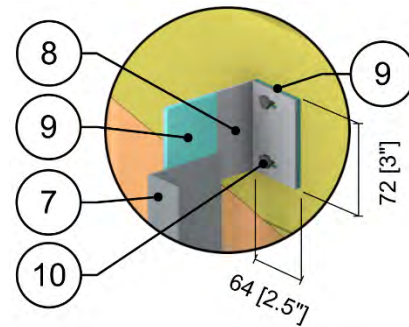
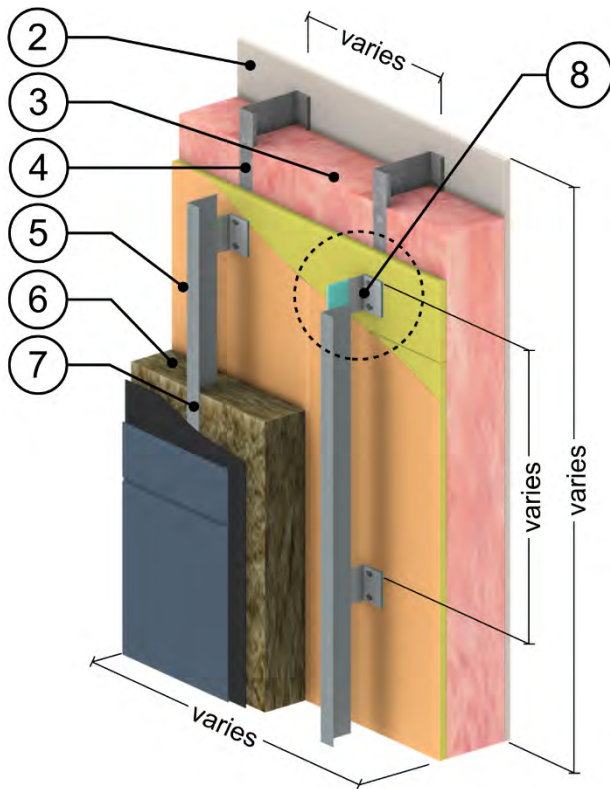

Clip Detail

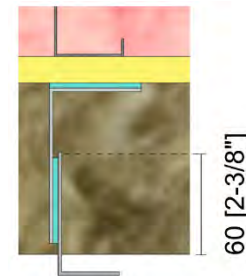

Girt Penetration Detail

ID	Component	Thickness Inches (mm)	Conductivity Btu-in / ft ² ·hr·°F (W/m K)	Nominal Resistance hr·ft ² ·°F/Btu (m ² K/W)	Density lb/ft ³ (kg/m ³)	Specific Heat Btu/lb·°F (J/kg K)
1	Interior Films ¹	-	-	R-0.7 (0.12 RSI)	-	-
2	Gypsum Board	1/2" (13)	1.1 (0.16)	R-0.5 (0.08 RSI)	50 (800)	0.26 (1090)
3	Fiberglass Batt Insulation	6" (152)	0.30(0.043)	R-20 (3.5 RSI)	0.55 (8.8)	0.17 (710)
4	6" x 1 5/8" Steel Studs	18 Gauge	430 (62)	-	489 (7830)	0.12 (500)
5	Exterior Sheathing	5/8" (16)	1.1 (0.16)	R-0.6 (0.10 RSI)	50 (800)	0.26 (1090)
6	Exterior Mineral Wool Insulation	Varies	0.24 (0.034)	R-16.8 to R-29.4 (2.96 to 5.18 RSI)	4 (64)	0.20 (850)
7	Vertical Aluminum L-girt – Aluminum 6005A alloy	0.09" (2.2)	1340 (193)	-	169 (2700)	0.22 (900)
8	Aluminum Bracket	0.09" (2.2)	1110 (160)	-	171 (2739)	0.22 (900)
9	HDPE Isolator	1/8" (3)	3.5 (0.5)	-	59 (950)	0.48 (2000)
10	#14 Stainless Steel Fasteners	1/4" (6) Ø	118 (17)	-	500 (8000)	0.12 (500)
11	Cladding with 1/2" vented airspace incorporated into exterior heat transfer coefficient					
12	Exterior Film ¹	-	-	R-0.7 (0.12 RSI)	-	-

¹ Value selected from table 1, p. 26.1 of 2009 ASHRAE Handbook – Fundamentals depending on surface orientation

Detail 5.1.60

Exterior and Interior Insulated 6" x 1 5/8" Steel Stud (16" o.c. and 24" o.c.) Wall Assembly with Steel Brick Anchors Supporting Brick Veneer and Owens Corning R-20 Batt Insulation in Stud Cavity – Clear Wall

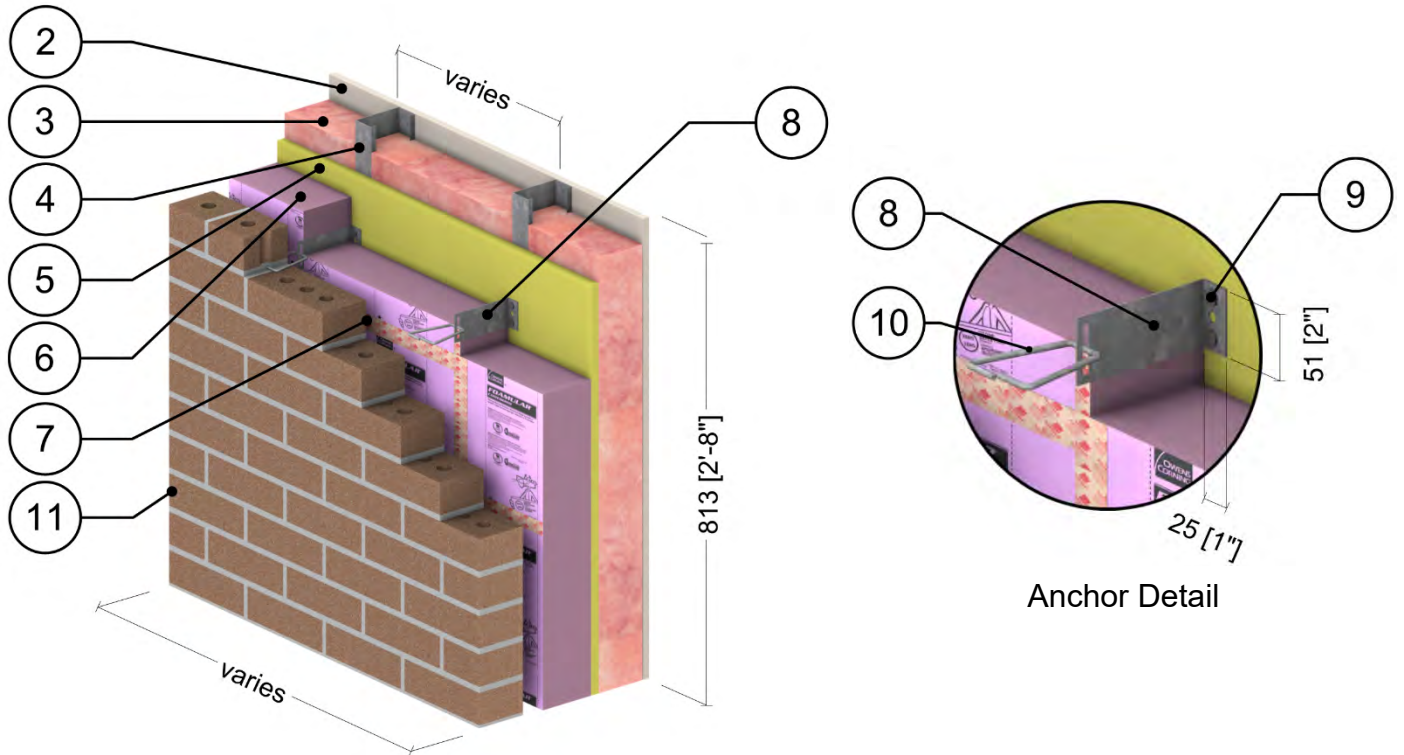

ID	Component	Thickness Inches (mm)	Conductivity Btu-in / ft ² ·hr·°F (W/m K)	Nominal Resistance hr·ft ² ·°F/Btu (m ² K/W)	Density lb/ft ³ (kg/m ³)	Specific Heat Btu/lb·°F (J/kg K)
1	Interior Films ¹	-	-	R-0.7 (0.12 RSI)	-	-
2	Gypsum Board	1/2" (13)	1.1 (0.16)	R-0.5 (0.08 RSI)	50 (800)	0.26 (1090)
3	Ecotouch Pink Fiberglass Batt	6" (152)	0.30 (0.043)	R-20 (3.5 RSI)	0.55 (8.8)	0.17 (710)
4	6" x 1 5/8" Steel Studs	18 Gauge	430 (62)	-	489 (7830)	0.12 (500)
5	Exterior Sheathing	5/8" (16)	1.1 (0.16)	R-0.6 (0.10 RSI)	50 (800)	0.26 (1090)
6	Foamular CodeBord/C-200 Extruded Polystyrene Rigid Insulation (XPS) Type 3	Varies	0.20 (0.029)	R-5 to R-15 (0.88 to 2.64 RSI)	Varies	0.29 (1220)
7	Vented Air Cavity	1 1/2" (38)	-	R-0.4 (0.07 RSI)	0.075 (1.2)	0.24 (1000)
8	Galvanized Steel Veneer Anchor	Varies	430 (62)	-	489 (7830)	0.12 (500)
9	Galvanized Steel Fasteners	0.28" (7) Ø	430 (62)	-	489 (7830)	0.12 (500)
10	Galvanized Steel Wire Pintle	-	430 (62)	-	489 (7830)	0.12 (500)
11	Brick Veneer	3 5/8" (92)	5.4 (0.78)	-	120 (1920)	0.19 (720)
12	Exterior Film ¹	-	-	R-0.2 (0.03 RSI)	-	-

¹ Value selected from table 1, p. 26.1 of 2009 ASHRAE Handbook – Fundamentals depending on surface orientation

Detail 5.1.61

Exterior and Interior Insulated 6" x 1 5/8" Steel Stud (16" o.c. and 24" o.c.) Wall Assembly with Steel Brick Anchors Supporting Brick Veneer and Owens Corning R-22.5 Batt Insulation in Stud Cavity – Clear Wall

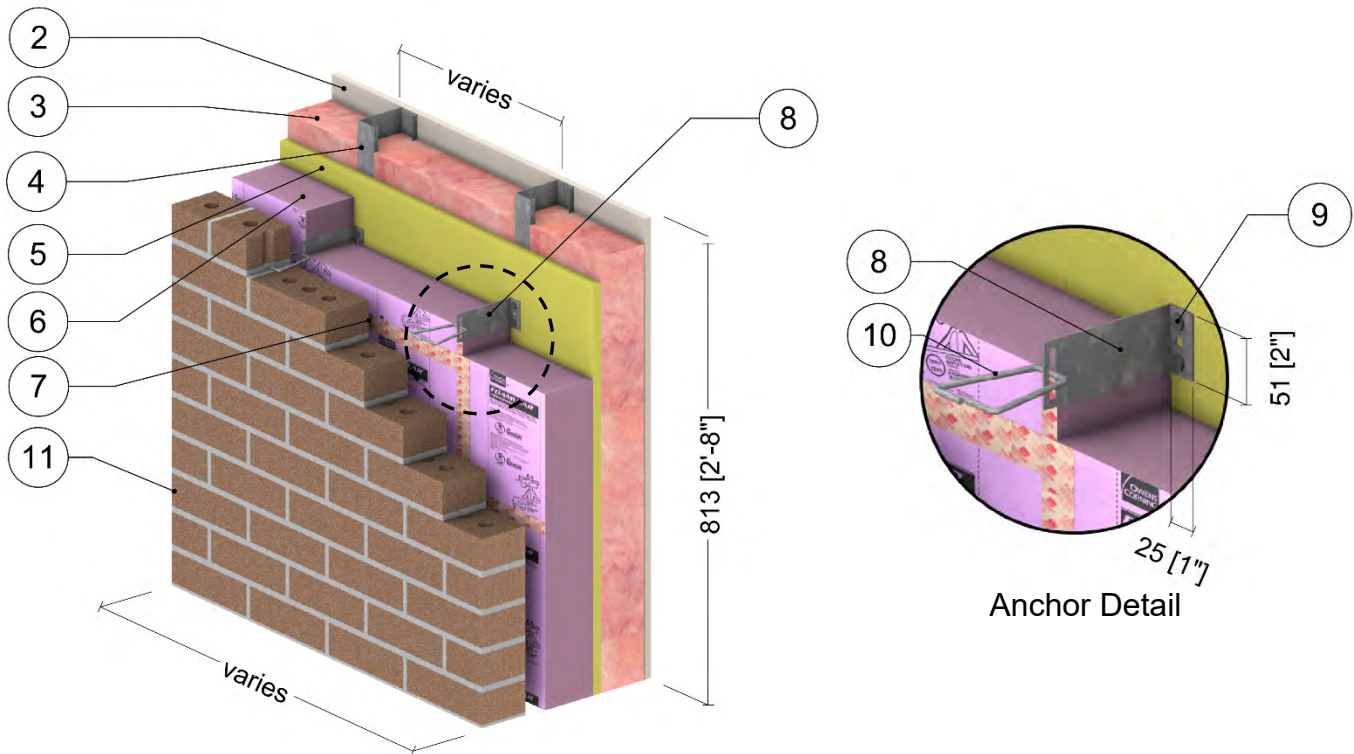

ID	Component	Thickness Inches (mm)	Conductivity Btu-in / ft ² -hr-°F (W/m K)	Nominal Resistance hr-ft ² -°F/Btu (m ² K/W)	Density lb/ft ³ (kg/m ³)	Specific Heat Btu/lb-°F (J/kg K)
1	Interior Films ¹	-	-	R-0.7 (0.12 RSI)	-	-
2	Gypsum Board	1/2" (13)	1.1 (0.16)	R-0.5 (0.09 RSI)	50 (800)	0.26 (1090)
3	Ecotouch Pink Fiberglass Batt	6" (152)	0.26 (0.038)	R-22.5 (4.0 RSI)	0.99 (15.9)	0.17 (710)
4	6" x 1 5/8" Steel Studs	18 Gauge	430 (62)	-	489 (7830)	0.12 (500)
5	Exterior Sheathing	5/8" (16)	1.1 (0.16)	R-0.6 (0.10 RSI)	50 (800)	0.26 (1090)
6	Foamular CodeBord/C-200 Extruded Polystyrene Rigid Insulation (XPS) Type 3	Varies	0.20 (0.029)	R-5 to R-15 (0.88 to 2.64 RSI)	Varies	0.29 (1220)
7	Vented Air Cavity	1 1/2" (38)	-	R-0.4 (0.07 RSI)	0.075 (1.2)	0.24 (1000)
8	Galvanized Steel Veneer Anchor	Varies	430 (62)	-	489 (7830)	0.12 (500)
9	Galvanized Steel Fasteners	0.28" (7) Ø	430 (62)	-	489 (7830)	0.12 (500)
10	Galvanized Steel Wire Pintle	-	430 (62)	-	489 (7830)	0.12 (500)
11	Brick Veneer	3 5/8" (92)	5.4 (0.78)	-	120 (1920)	0.19 (720)
12	Exterior Film ¹	-	-	R-0.2 (0.03 RSI)	-	-

¹ Value selected from table 1, p. 26.1 of 2009 ASHRAE Handbook – Fundamentals depending on surface orientation

Detail 5.1.62

Exterior and Interior Insulated 6" x 1 5/8" Steel Stud (16" o.c. and 24" o.c.) Wall Assembly with Steel Brick Anchors Supporting Brick Veneer and Owens Corning R-24 Batt Insulation in Stud Cavity – Clear Wall

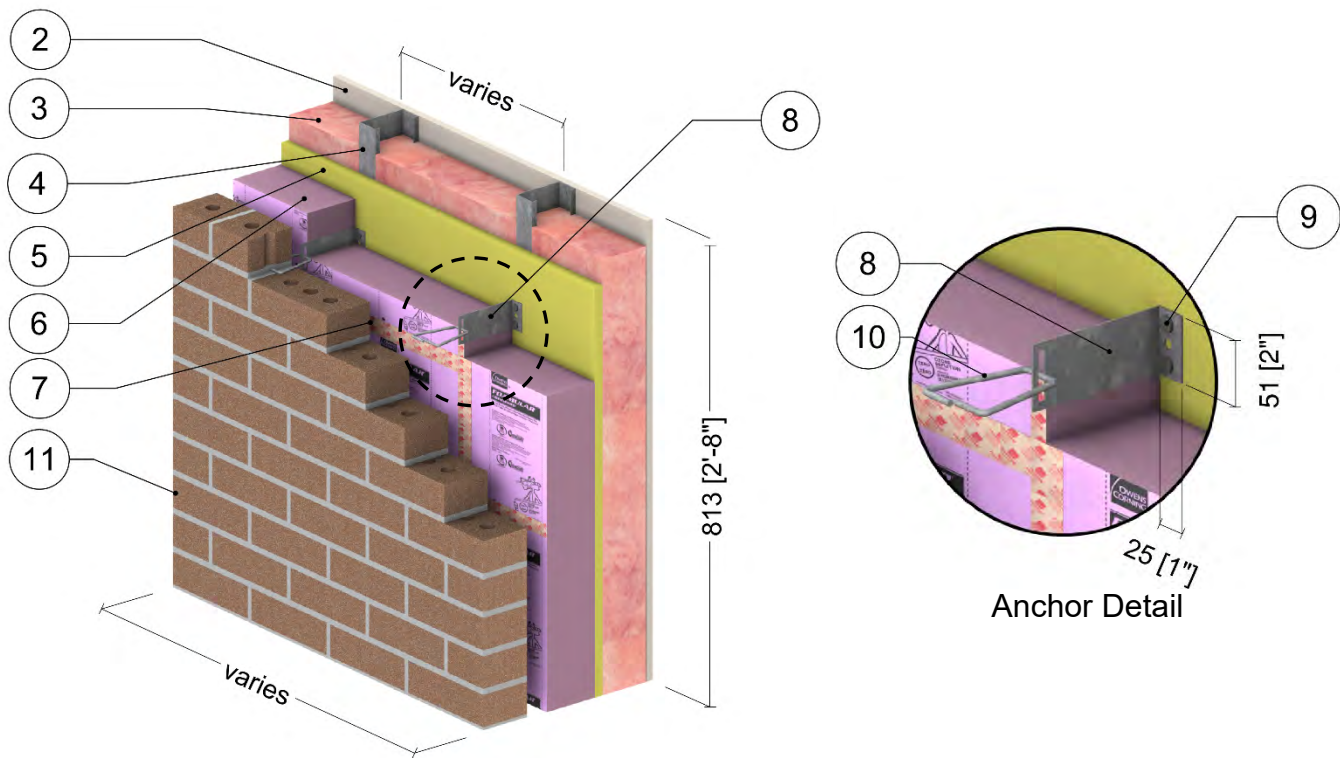

ID	Component	Thickness Inches (mm)	Conductivity Btu-in / ft ² -hr-°F (W/m K)	Nominal Resistance hr-ft ² -°F/Btu (m ² K/W)	Density lb/ft ³ (kg/m ³)	Specific Heat Btu/lb-°F (J/kg K)
1	Interior Films ¹	-	-	R-0.7 (0.12 RSI)	-	-
2	Gypsum Board	1/2" (13)	1.1 (0.16)	R-0.5 (0.09 RSI)	50 (800)	0.26 (1090)
3	Ecotouch Pink Fiberglass Batt	6" (152)	0.25 (0.036)	R-24 (4.2 RSI)	1.42 (22.7)	0.17 (710)
4	6" x 1 5/8" Steel Studs	18 Gauge	430 (62)	-	489 (7830)	0.12 (500)
5	Exterior Sheathing	5/8" (16)	1.1 (0.16)	R-0.6 (0.10 RSI)	50 (800)	0.26 (1090)
6	Foamular CodeBord/C-200 Extruded Polystyrene Rigid Insulation (XPS) Type 3	Varies	0.20 (0.029)	R-5 to R-15 (0.88 to 2.64 RSI)	Varies	0.29 (1220)
7	Vented Air Cavity	1 1/2" (38)	-	R-0.4 (0.07 RSI)	0.075 (1.2)	0.24 (1000)
8	Galvanized Steel Veneer Anchor	Varies	430 (62)	-	489 (7830)	0.12 (500)
9	Galvanized Steel Fasteners	0.28" (7) Ø	430 (62)	-	489 (7830)	0.12 (500)
10	Galvanized Steel Wire Pintle	-	430 (62)	-	489 (7830)	0.12 (500)
11	Brick Veneer	3 5/8" (92)	5.4 (0.78)	-	120 (1920)	0.19 (720)
12	Exterior Film ¹	-	-	R-0.2 (0.03 RSI)	-	-

¹ Value selected from table 1, p. 26.1 of 2009 ASHRAE Handbook – Fundamentals depending on surface orientation

Detail 5.1.63

Exterior and Interior Insulated 6" x 1 5/8" Steel Stud (16" o.c.) Wall Assembly with Heckmann Pos-I-Tie Veneer Anchoring System Supporting Brick Veneer and Owens Corning R-20 Batt Insulation in Stud Cavity – Clear Wall

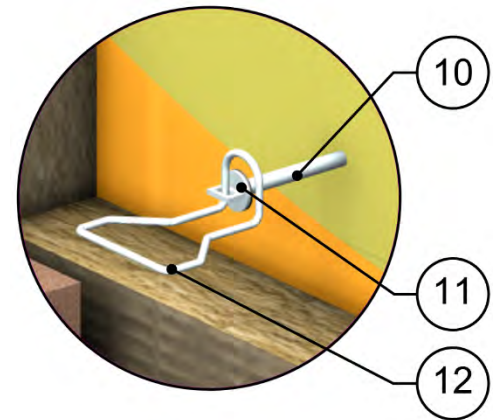
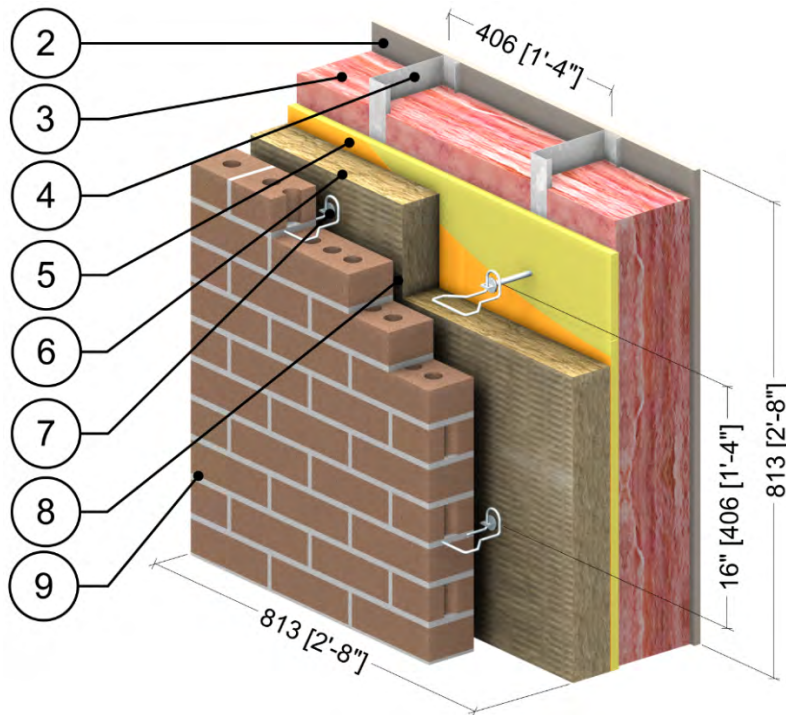

Anchor Detail

ID	Component	Thickness Inches (mm)	Conductivity Btu-in / ft ² ·hr·°F (W/m K)	Nominal Resistance hr·ft ² ·°F/Btu (m ² K/W)	Density lb/ft ³ (kg/m ³)	Specific Heat Btu/lb·°F (J/kg K)
1	Interior Film ¹	-	-	R-0.7 (0.12 RSI)	-	-
2	Gypsum Board	1/2" (13)	1.1 (0.16)	R-0.5 (0.08 RSI)	50 (800)	0.26 (1090)
3	Ecotouch Pink Fiberglass Batt	6" (152)	0.30 (0.043)	R-20 (3.5 RSI)	0.55 (8.8)	0.17 (710)
4	6" x 1 5/8" Steel Studs	18 Gauge	430 (62)	-	489 (7830)	0.12 (500)
5	Exterior Sheathing	5/8" (16)	1.1 (0.16)	R-0.6 (0.10 RSI)	50 (800)	0.26 (1090)
6	Thermafiber RainBarrier 45 Mineral Wool Semi Rigid Insulation	Varies	0.24 (0.034)	R-6.3 to R-21.0 (1.11 to 3.70 RSI)	4.5 (72)	0.29 (1220)
7	Heckmann Pos-I-Tie Masonry Tie 16" (406) o.c.	Varies	-	-	-	-
8	Vented Air Cavity ²	1.5" (38)	-	R-0.4 (0.07 RSI)	0.075 (1.2)	0.24 (1000)
9	Brick Veneer	3 5/8" (92)	5.4 (0.78)	-	120 (1920)	0.19 (720)
10	Zinc Barrel	-	726 (105)	-	412 (6600)	-
11	Rubber Washer (EPDM)	1/16" (1.59)	1.7 (0.25)	-	62 (997)	-
12	Galvanized Steel Wire Pintle	3/16" (5) Ø	645 (93)	-	489 (7830)	0.12 (500)
13	Exterior Film ¹	-	-	R-0.2 (0.03 RSI)	-	-

¹ Value selected from table 1, p. 26.1 of 2009 ASHRAE Handbook – Fundamentals depending on surface orientation

² The thermal conductivity of air spaces was found using ISO 100077-2

Detail 5.1.64

Exterior and Interior Insulated 6" x 1 5/8" Steel Stud (16" o.c.) Wall Assembly with Heckmann Pos-I-Tie Veneer Anchoring System Supporting Brick Veneer and Owens Corning R-22.5 Batt Insulation in Stud Cavity – Clear Wall

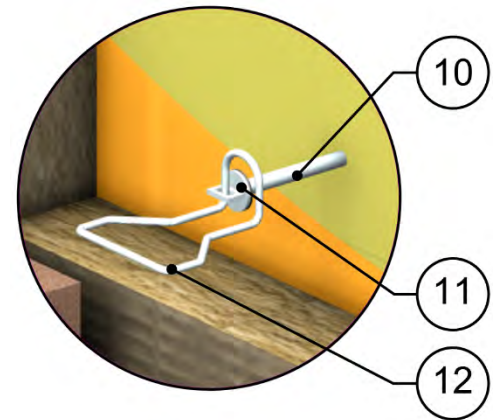
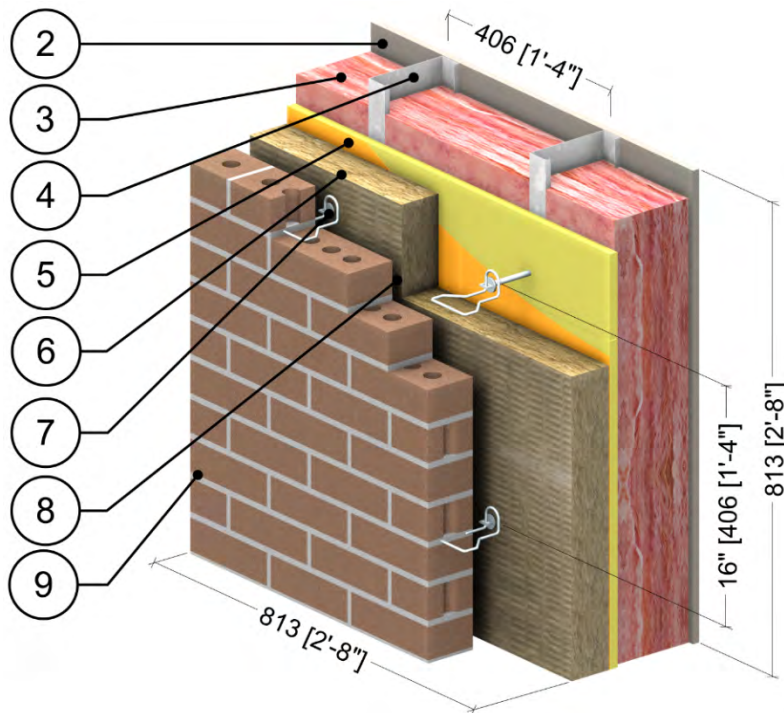

Anchor Detail

ID	Component	Thickness Inches (mm)	Conductivity Btu-in / ft ² ·hr·°F (W/m K)	Nominal Resistance hr·ft ² ·°F/Btu (m ² K/W)	Density lb/ft ³ (kg/m ³)	Specific Heat Btu/lb·°F (J/kg K)
1	Interior Film ¹	-	-	R-0.7 (0.12 RSI)	-	-
2	Gypsum Board	1/2" (13)	1.1 (0.16)	R-0.5 (0.08 RSI)	50 (800)	0.26 (1090)
3	Ecotouch Pink Fiberglass Batt	6" (152)	0.26 (0.038)	R-22.5 (4.0 RSI)	0.99 (15.9)	0.17 (710)
4	6" x 1 5/8" Steel Studs	18 Gauge	430 (62)	-	489 (7830)	0.12 (500)
5	Exterior Sheathing	5/8" (16)	1.1 (0.16)	R-0.6 (0.10 RSI)	50 (800)	0.26 (1090)
6	Thermafiber RainBarrier 45 Mineral Wool Semi Rigid Insulation	Varies	0.24 (0.034)	R-6.3 to R-21.0 (1.11 to 3.70 RSI)	4.5 (72)	0.29 (1220)
7	Heckmann Pos-I-Tie Masonry Tie 16" (406) o.c.	Varies	-	-	-	-
8	Vented Air Cavity ²	1.5" (38)	-	R-0.4 (0.07 RSI)	0.075 (1.2)	0.24 (1000)
9	Brick Veneer	3 5/8" (92)	5.4 (0.78)	-	120 (1920)	0.19 (720)
10	Zinc Barrel	-	726 (105)	-	412 (6600)	-
11	Rubber Washer (EPDM)	1/16" (1.59)	1.7 (0.25)	-	62 (997)	-
12	Galvanized Steel Wire Pintle	3/16" (5) Ø	645 (93)	-	489 (7830)	0.12 (500)
13	Exterior Film ¹	-	-	R-0.2 (0.03 RSI)	-	-

¹ Value selected from table 1, p. 26.1 of 2009 ASHRAE Handbook – Fundamentals depending on surface orientation

² The thermal conductivity of air spaces was found using ISO 100077-2

Detail 5.1.65

Exterior and Interior Insulated 6" x 1 5/8" Steel Stud (16" o.c.) Wall Assembly with Heckmann Pos-I-Tie Veneer Anchoring System Supporting Brick Veneer and Owens Corning R-24 Batt Insulation in Stud Cavity – Clear Wall

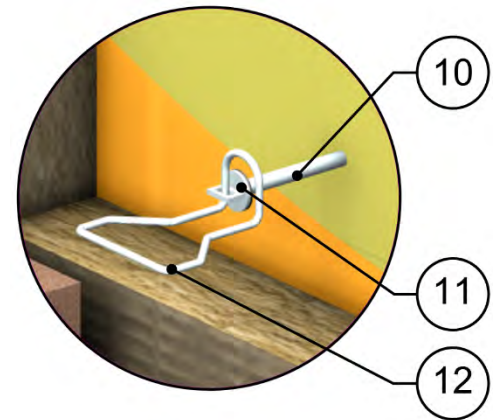
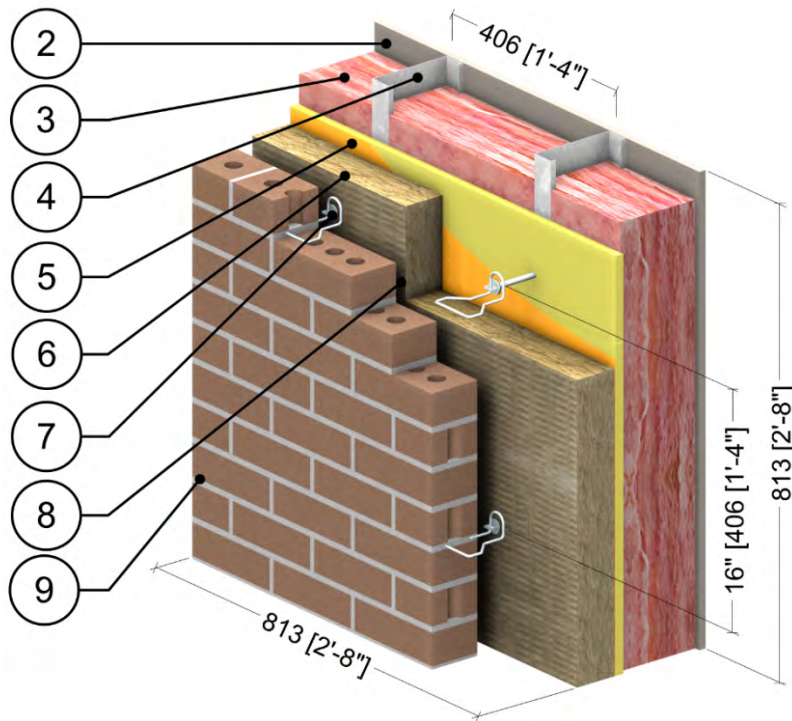

Anchor Detail

ID	Component	Thickness Inches (mm)	Conductivity Btu-in / ft ² ·hr·°F (W/m K)	Nominal Resistance hr·ft ² ·°F/Btu (m ² K/W)	Density lb/ft ³ (kg/m ³)	Specific Heat Btu/lb·°F (J/kg K)
1	Interior Film ¹	-	-	R-0.7 (0.12 RSI)	-	-
2	Gypsum Board	1/2" (13)	1.1 (0.16)	R-0.5 (0.08 RSI)	50 (800)	0.26 (1090)
3	Ecotouch Pink Fiberglass Batt	6" (152)	0.25 (0.036)	R-24 (4.2 RSI)	1.42 (22.7)	0.17 (710)
4	6" x 1 5/8" Steel Studs	18 Gauge	430 (62)	-	489 (7830)	0.12 (500)
5	Exterior Sheathing	5/8" (16)	1.1 (0.16)	R-0.6 (0.10 RSI)	50 (800)	0.26 (1090)
6	Thermafiber RainBarrier 45 Mineral Wool Semi Rigid Insulation	Varies	0.24 (0.034)	R-6.3 to R-21.0 (1.11 to 3.70 RSI)	4.5 (72)	0.29 (1220)
7	Heckmann Pos-I-Tie Masonry Tie 16" (406) o.c.	Varies	-	-	-	-
8	Vented Air Cavity ²	1.5" (38)	-	R-0.4 (0.07 RSI)	0.075 (1.2)	0.24 (1000)
9	Brick Veneer	3 5/8" (92)	5.4 (0.78)	-	120 (1920)	0.19 (720)
10	Zinc Barrel	-	726 (105)	-	412 (6600)	-
11	Rubber Washer (EPDM)	1/16" (1.59)	1.7 (0.25)	-	62 (997)	-
12	Galvanized Steel Wire Pintle	3/16" (5) Ø	645 (93)	-	489 (7830)	0.12 (500)
13	Exterior Film ¹	-	-	R-0.2 (0.03 RSI)	-	-

¹ Value selected from table 1, p. 26.1 of 2009 ASHRAE Handbook – Fundamentals depending on surface orientation

² The thermal conductivity of air spaces was found using ISO 100077-2

Detail 5.1.66

Exterior and Interior Insulated 6" x 1 5/8" Steel Stud (16" o.c.) Wall Assembly with Steel Anchor Supporting Brick Veneer, Owens Corning XPS Exterior Insulation and R-20 Batt Insulation in Stud Cavity – Clear Wall

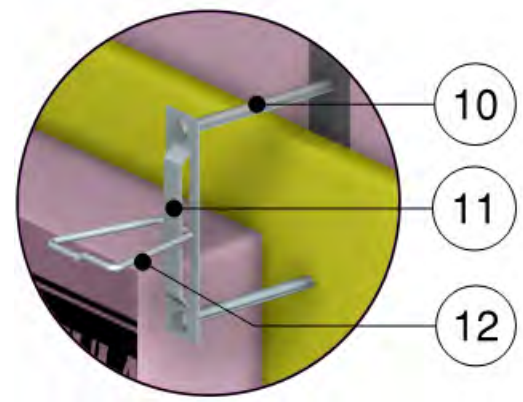
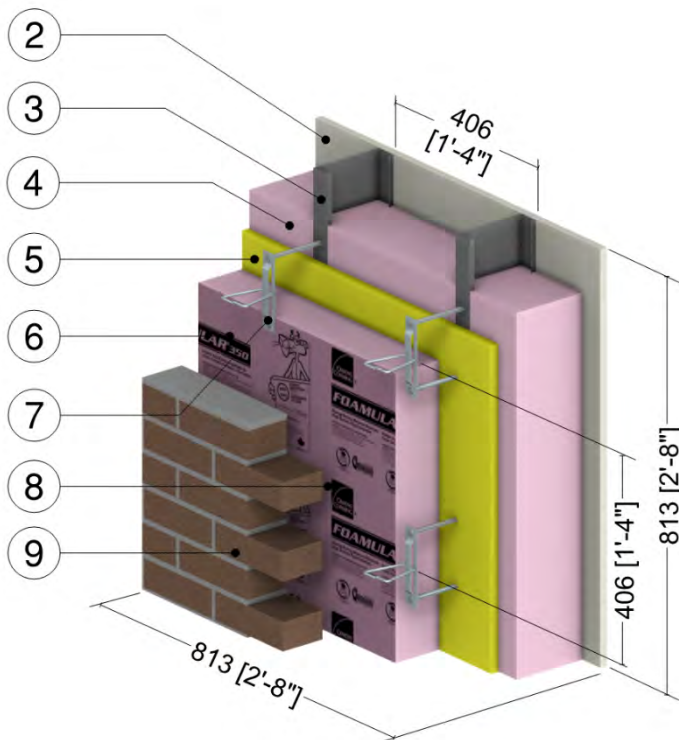

X-Seal Byna-Lok Anchor Detail

ID	Component	Thickness Inches (mm)	Conductivity Btu-in / ft ² -hr-°F (W/m K)	Nominal Resistance hr-ft ² -°F/Btu (m ² K/W)	Density lb/ft ³ (kg/m ³)	Specific Heat Btu/lb-°F (J/kg K)
1	Interior Film ¹	-	-	R-0.7 (0.12 RSI)	-	-
2	Gypsum Board	5/8" (16)	1.1 (0.16)	R-0.6 (0.10 RSI)	50 (800)	0.26 (1090)
3	6" x 1 5/8" Steel Studs	18 Gauge	430 (62)	-	489 (7830)	0.12 (500)
4	Ecotouch Pink Fiberglass Batt	6" (152)	0.30 (0.043)	R-20 (3.52 RSI)	0.55 (8.8)	0.17 (710)
5	Exterior Sheathing	5/8" (16)	1.1 (0.16)	R-0.6 (0.10 RSI)	50 (800)	0.26 (1090)
6	FOAMULAR 250 extruded polystyrene insulation (XPS, Type IV)	Varies	0.20 (0.029)	R-5 to R-25 (0.88 to 4.40 RSI)	1.55 (25)	0.29 (1220)
7	Hohmann and Barnard X-Seal Byna-Lok Anchor	1" to 4" (25 to 102)	347 (50)	-	-	-
8	Vented Air Cavity	1.5" (38)	-	R-0.4 (0.70 RSI)	0.075 (1.2)	0.24 (1000)
9	Brick Veneer	3-5/8" (92)	5.4 (0.78)	-	120 (1920)	0.19 (720)
10	X-Seal Steel Veneer Anchor	0.31" (8) Ø	347 (50)	-	489 (7830)	0.12 (500)
11	Byna-Lok Steel Tie	-	347 (50)	-	489 (7830)	0.12 (500)
12	Steel Wire	-	347 (50)	-	489 (7830)	0.12 (500)
13	Exterior Film ¹	-	-	R-0.2 (0.03 RSI)	-	-

¹ Value selected from table 1, p. 26.1 of 2009 ASHRAE Handbook – Fundamentals depending on surface orientation



Detail 5.1.67 Exterior Insulated 3 5/8" x 1 5/8" Steel Stud (16" o.c.) Wall Assembly with Hohmann & Barnard Masonry Zinc 2-Seal Anchor Supporting Brick Veneer – Clear Wall

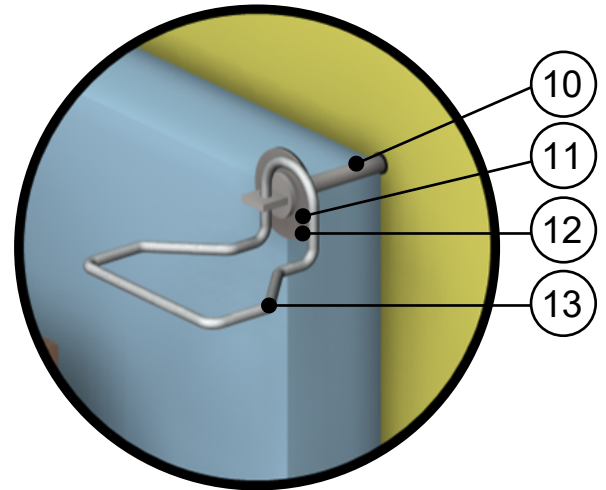
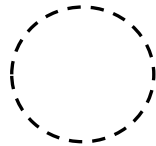

Anchor Detail

ID	Component	Thickness Inches (mm)	Conductivity Btu-in / ft ² ·hr·°F (W/m K)	Nominal Resistance hr·ft ² ·°F/Btu (m ² K/W)	Density lb/ft ³ (kg/m ³)	Specific Heat Btu/lb·°F (J/kg K)
1	Interior Film ¹	-	-	R-0.7 (0.12 RSI)	-	-
2	Gypsum Board	1/2" (13)	1.1 (0.16)	R-0.5 (0.08 RSI)	50 (800)	0.26 (1090)
3	Air in Stud Cavity	3 5/8" (92)	-	R-0.9 (0.16 RSI)	0.075 (1.2)	0.24 (1000)
4	3 5/8" x 1 5/8" Steel Studs	18 Gauge	430 (62)	-	489 (7830)	0.12 (500)
5	Exterior Sheathing	5/8" (16)	1.1 (0.16)	R-0.6 (0.10 RSI)	50 (800)	0.26 (1090)
6	Exterior Mineral Wool Insulation	1" to 4" (25 to 102)	0.24 (0.034)	R-4.2 to R-16.8 (0.74 to 2.96 RSI)	4 (64)	0.20 (850)
7	Brick Tie	1" to 4" (25 to 102)	Varies	-	-	-
8	Vented Air Cavity	1.5" (38)	-	R-0.4 (0.07 RSI)	0.075 (1.2)	0.24 (1000)
9	Brick Veneer	3 5/8" (92)	5.4 (0.78)	-	120 (1920)	0.19 (720)
10	Zinc Barrel	-	784 (113)	-	-	-
11	Steel Washer	1.5" (38) Ø	347 (50)	-	489 (7830)	0.12 (500)
12	Rubber Washer (EPDM)	-	1.7 (0.25)	-	-	-
13	Galvanized Steel Wire Pintle	3/16" (5) Ø	430 (62)	-	489 (7830)	0.12 (500)
14	Exterior Film ¹	-	-	R-0.2 (0.03 RSI)	-	-

¹ Value selected from table 1, p. 26.1 of 2009 ASHRAE Handbook – Fundamentals depending on surface orientation

Detail 5.1.68

Exterior Insulated 3 5/8" x 1 5/8" Steel Stud (16" o.c.) Wall Assembly with Hohmann & Barnard Masonry Stainless Steel 2-Seal Thermal Anchor Supporting Brick Veneer – Clear Wall

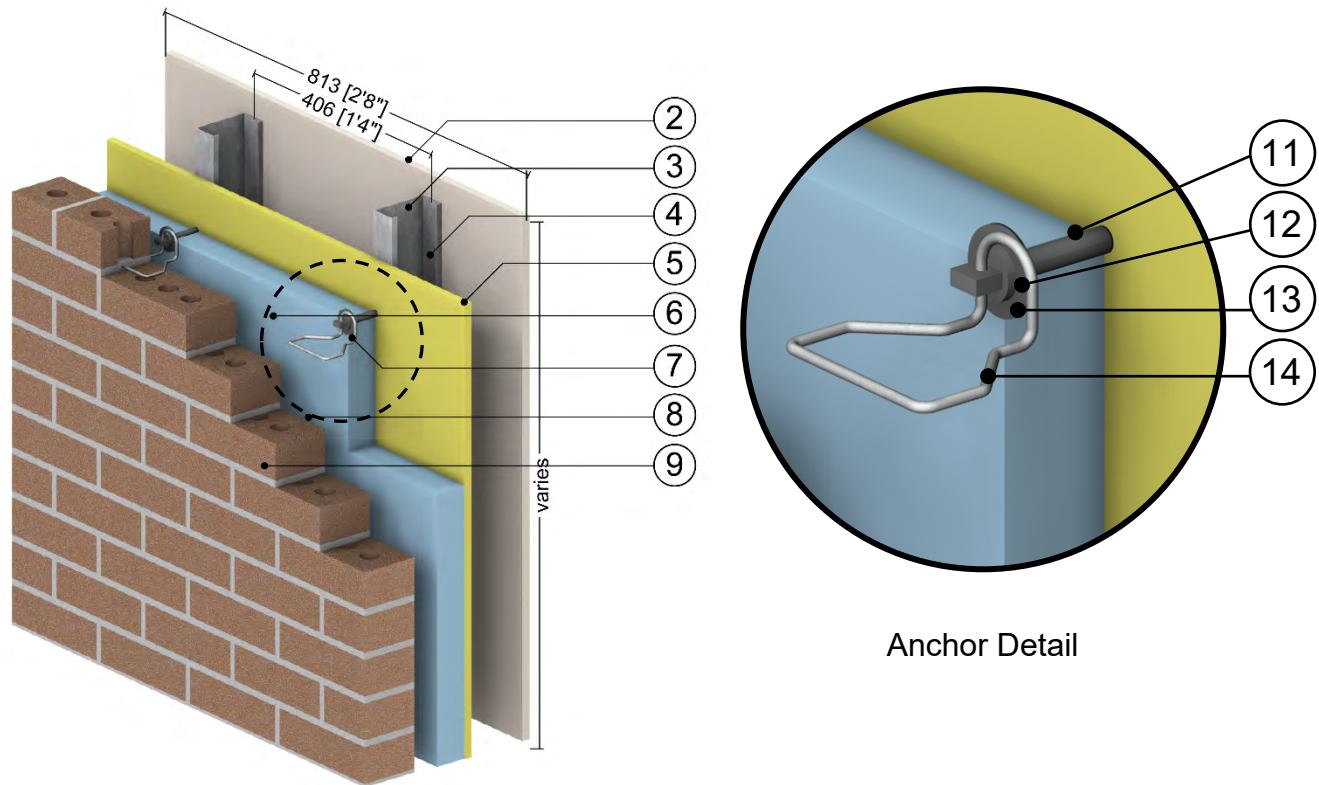

ID	Component	Thickness Inches (mm)	Conductivity Btu-in / ft ² -hr-°F (W/m K)	Nominal Resistance hr-ft ² -°F/Btu (m ² K/W)	Density lb/ft ³ (kg/m ³)	Specific Heat Btu/lb-°F (J/kg K)
1	Interior Film ¹	-	-	R-0.7 (0.12 RSI)	-	-
2	Gypsum Board	1/2" (13)	1.1 (0.16)	R-0.5 (0.08 RSI)	50 (800)	0.26 (1090)
3	Air in Stud Cavity	3 5/8" (92)	-	R-0.9 (0.16 RSI)	0.075 (1.2)	0.24 (1000)
4	3 5/8" x 1 5/8" Steel Studs	18 Gauge	430 (62)	-	489 (7830)	0.12 (500)
5	Exterior Sheathing	5/8" (16)	1.1 (0.16)	R-0.6 (0.10 RSI)	50 (800)	0.26 (1090)
6	Exterior Mineral Wool Insulation	1" to 4" (25 to 102)	0.24 (0.034)	R-4.2 to R-16.8 (0.74 to 2.96 RSI)	4 (64)	0.20 (850)
7	Brick Tie	1" to 4" (25 to 102)	Varies	-	-	-
8	Vented Air Cavity	1.5" (38)	-	R-0.4 (0.07 RSI)	0.075 (1.2)	0.24 (1000)
9	Brick Veneer	3 5/8" (92)	5.4 (0.78)	-	120 (1920)	0.19 (720)
10	Stainless Steel Barrel	-	118 (17)	-	489 (7830)	0.12 (500)
11	Nylon Coating	Varies	1.7 (0.25)	-	-	-
12	Steel Washer	1.5" (38) Ø	347 (50)	-	489 (7830)	0.12 (500)
13	Rubber Washer (EPDM)	-	1.7 (0.25)	-	-	-
14	Galvanized Steel Wire Pintle	3/16" (5) Ø	430 (62)	-	489 (7830)	0.12 (500)
15	Exterior Film ¹	-	-	R-0.2 (0.03 RSI)	-	-

¹ Value selected from table 1, p. 26.1 of 2009 ASHRAE Handbook – Fundamentals depending on surface orientation

Detail 5.1.69 Exterior Insulated 3 5/8" x 1 5/8" Steel Stud (16" o.c.) Wall Assembly with Hohmann & Barnard Masonry Stainless Steel 2-Seal Thermal Wing Nut Anchor Supporting Brick Veneer – Clear Wall

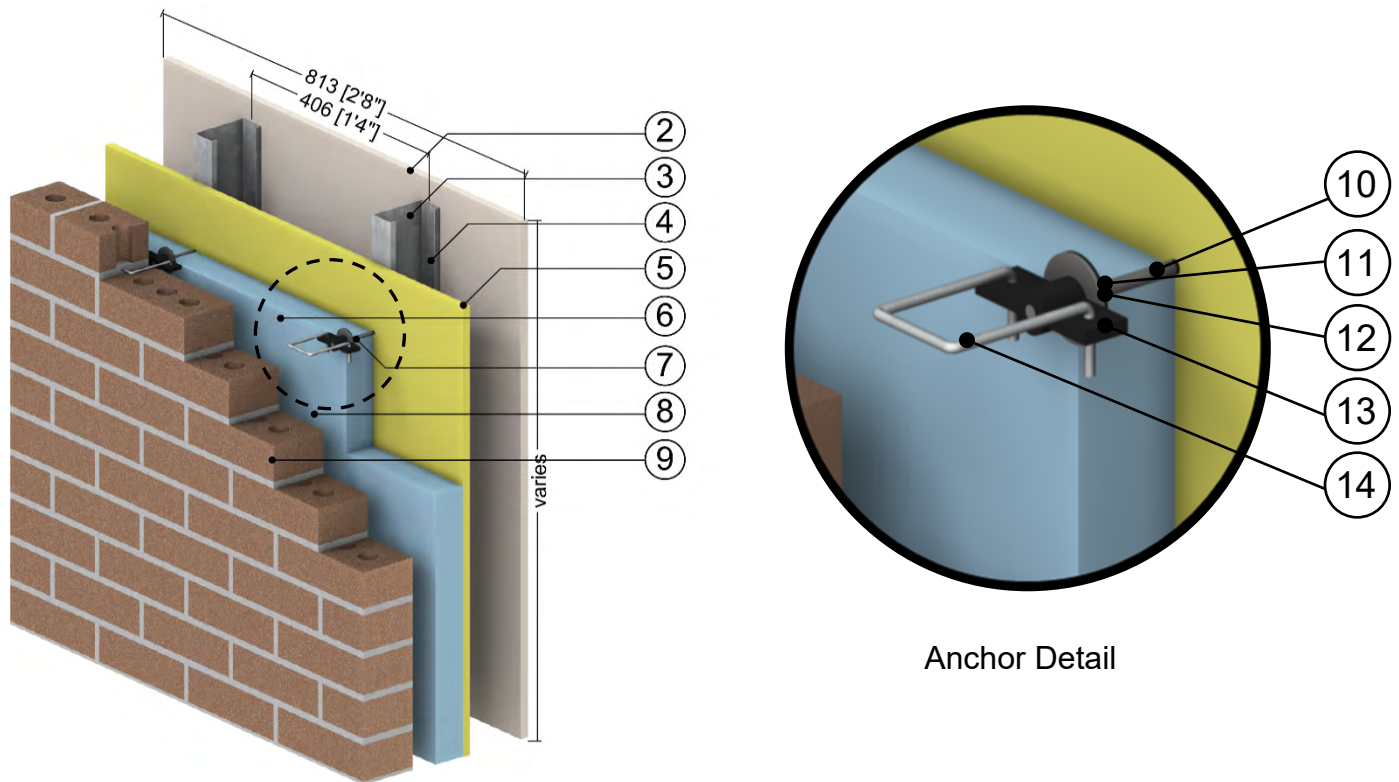

ID	Component	Thickness Inches (mm)	Conductivity Btu-in / ft ² ·hr·°F (W/m K)	Nominal Resistance hr·ft ² ·°F/Btu (m ² K/W)	Density lb/ft ³ (kg/m ³)	Specific Heat Btu/lb·°F (J/kg K)
1	Interior Film ¹	-	-	R-0.7 (0.12 RSI)	-	-
2	Gypsum Board	1/2" (13)	1.1 (0.16)	R-0.5 (0.08 RSI)	50 (800)	0.26 (1090)
3	Air in Stud Cavity	3 5/8" (92)	-	R-0.9 (0.16 RSI)	0.075 (1.2)	0.24 (1000)
4	3 5/8" x 1 5/8" Steel Studs	18 Gauge	430 (62)	-	489 (7830)	0.12 (500)
5	Exterior Sheathing	5/8" (16)	1.1 (0.16)	R-0.6 (0.10 RSI)	50 (800)	0.26 (1090)
6	Exterior Insulation (Mineral Wool)	1" to 4" (25 to 102)	0.24 (0.034)	R-4.2 to R-16.8 (0.74 to 2.96 RSI)	4 (64)	0.20 (850)
7	Brick Tie	1" to 4" (25 to 102)	Varies	-	-	-
8	Vented Air Cavity	1.5" (38)	-	R-0.4 (0.07 RSI)	0.075 (1.2)	0.24 (1000)
9	Brick Veneer	3 5/8" (92)	5.4 (0.78)	-	120 (1920)	0.19 (720)
10	Stainless Steel Barrel	-	118 (17)	-	489 (7830)	0.12 (500)
11	Steel Washer	1.5" (38) Ø	347 (50)	-	489 (7830)	0.12 (500)
12	Rubber Washer (EPDM)	-	1.7 (0.25)	-	-	-
13	Steel Wing Nut with Plastic Coating	Varies	347 (50)	-	489 (7830)	0.12 (500)
14	Galvanized Steel Wire Pintle	3/16" (5) Ø	430 (62)	-	489 (7830)	0.12 (500)
15	Exterior Film ¹	-	-	R-0.2 (0.03 RSI)	-	-

¹ Value selected from table 1, p. 26.1 of 2009 ASHRAE Handbook – Fundamentals depending on surface orientation

Detail 5.1.70

Exterior Insulated 3 5/8" x 1 5/8" Steel Stud (16" o.c.) Wall Assembly with Hohmann & Barnard Masonry Carbon Steel X-Seal Anchor Supporting Brick Veneer – Clear Wall

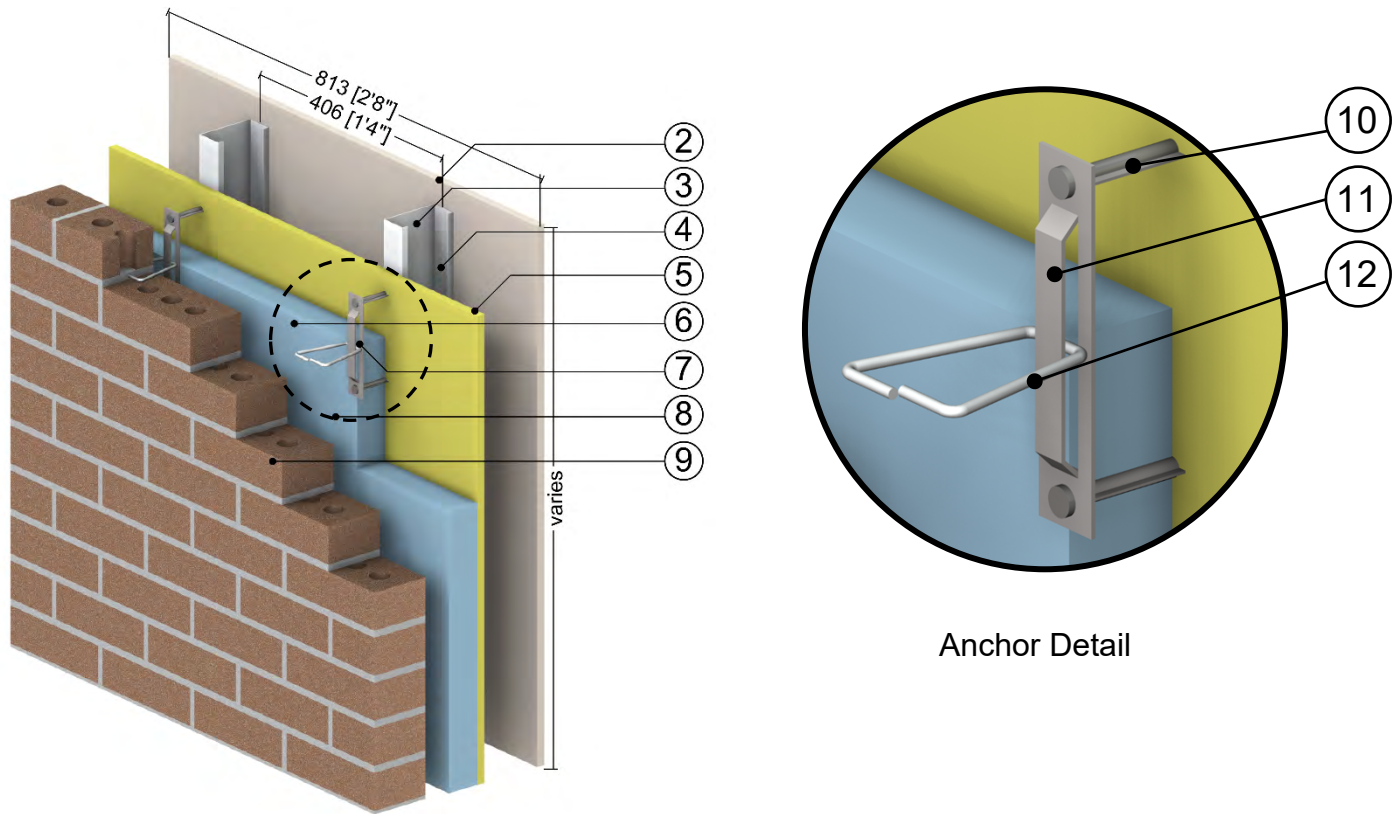

ID	Component	Thickness Inches (mm)	Conductivity Btu-in / ft ² ·hr·°F (W/m K)	Nominal Resistance hr·ft ² ·°F/Btu (m ² K/W)	Density lb/ft ³ (kg/m ³)	Specific Heat Btu/lb·°F (J/kg K)
1	Interior Film ¹	-	-	R-0.7 (0.12 RSI)	-	-
2	Gypsum Board	1/2" (13)	1.1 (0.16)	R-0.5 (0.08 RSI)	50 (800)	0.26 (1090)
3	Air in Stud Cavity	3 5/8" (92)	-	R-0.9 (0.16 RSI)	0.075 (1.2)	0.24 (1000)
4	3 5/8" x 1 5/8" Steel Studs	18 Gauge	430 (62)	-	489 (7830)	0.12 (500)
5	Exterior Sheathing	5/8" (16)	1.1 (0.16)	R-0.6 (0.10 RSI)	50 (800)	0.26 (1090)
6	Exterior Mineral Wool Insulation	1" to 4" (25 to 102)	0.24 (0.034)	R-4.2 to R-16.8 (0.74 to 2.96 RSI)	4 (64)	0.20 (850)
7	Brick Tie	1" to 4" (25 to 102)	Varies	-	-	-
8	Vented Air Cavity	1.5" (38)	-	R-0.4 (0.07 RSI)	0.075 (1.2)	0.24 (1000)
9	Brick Veneer	3 5/8" (92)	5.4 (0.78)	-	120 (1920)	0.19 (720)
10	Steel Fasteners	0.31" (8) Ø	347 (50)	-	489 (7830)	0.12 (500)
11	Steel Veneer Anchor	-	347 (50)	-	489 (7830)	0.12 (500)
12	Steel Triangle Tie	-	347 (50)	-	489 (7830)	0.12 (500)
13	Exterior Film ¹	-	-	R-0.2 (0.03 RSI)	-	-

¹ Value selected from table 1, p. 26.1 of 2009 ASHRAE Handbook – Fundamentals depending on surface orientation

Detail 5.1.71

Exterior Insulated 3 5/8" x 1 5/8" Steel Stud (16" o.c.) Wall Assembly with Hohmann & Barnard Masonry Stainless Steel X-Seal Anchor Supporting Brick Veneer – Clear Wall

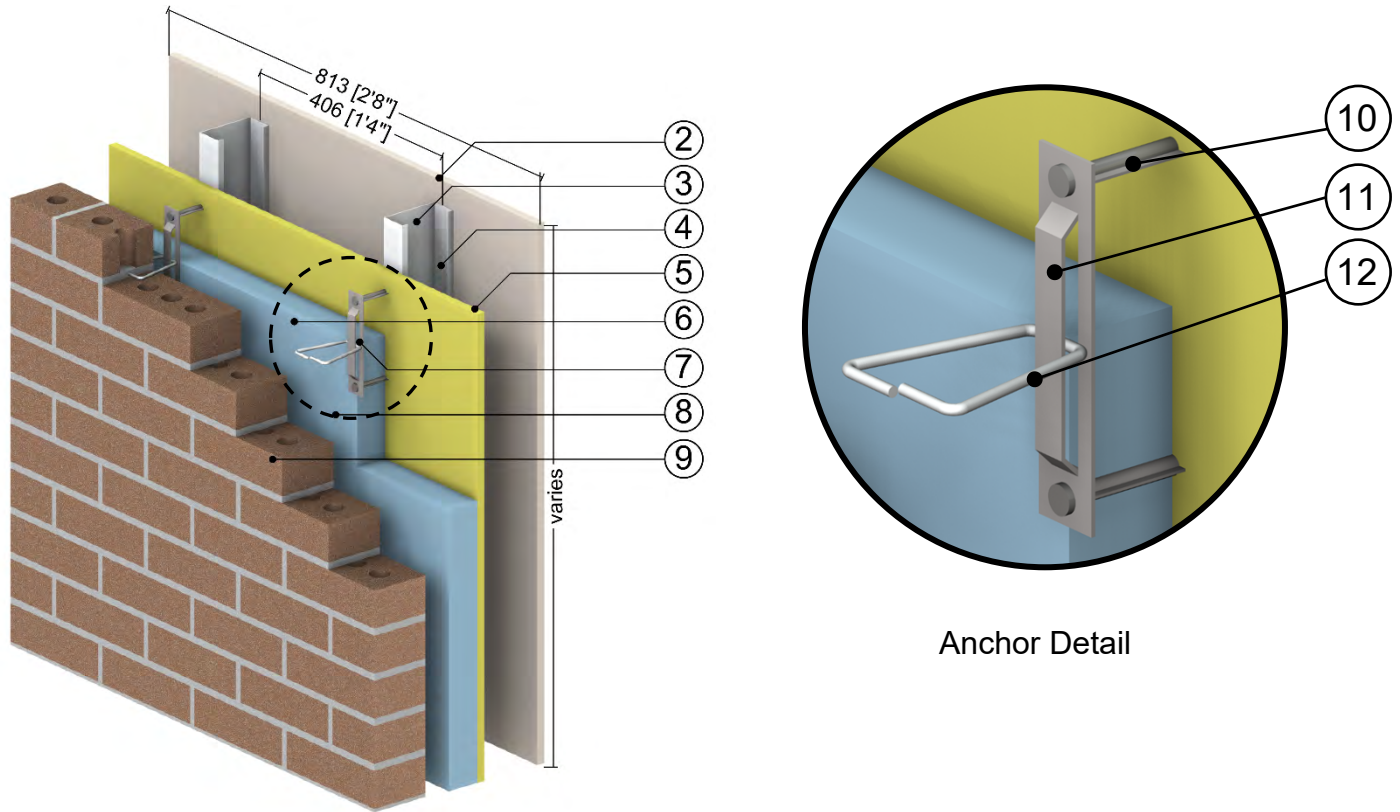

ID	Component	Thickness Inches (mm)	Conductivity Btu-in / ft ² ·hr·°F (W/m K)	Nominal Resistance hr·ft ² ·°F/Btu (m ² K/W)	Density lb/ft ³ (kg/m ³)	Specific Heat Btu/lb·°F (J/kg K)
1	Interior Film ¹	-	-	R-0.7 (0.12 RSI)	-	-
2	Gypsum Board	1/2" (13)	1.1 (0.16)	R-0.5 (0.08 RSI)	50 (800)	0.26 (1090)
3	Air in Stud Cavity	3 5/8" (92)	-	R-0.9 (0.16 RSI)	0.075 (1.2)	0.24 (1000)
4	3 5/8" x 1 5/8" Steel Studs	18 Gauge	430 (62)	-	489 (7830)	0.12 (500)
5	Exterior Sheathing	5/8" (16)	1.1 (0.16)	R-0.6 (0.10 RSI)	50 (800)	0.26 (1090)
6	Exterior Mineral Wool Insulation	1" to 4" (25 to 102)	0.24 (0.034)	R-4.2 to R-16.8 (0.74 to 2.96 RSI)	4 (64)	0.20 (850)
7	Brick Tie	1" to 4" (25 to 102)	Varies	-	-	-
8	Vented Air Cavity	1.5" (38)	-	R-0.4 (0.07 RSI)	0.075 (1.2)	0.24 (1000)
9	Brick Veneer	3 5/8" (92)	5.4 (0.78)	-	120 (1920)	0.19 (720)
10	Stainless Steel Fasteners	0.31" (8) Ø	118 (17)	-	489 (7830)	0.12 (500)
11	Stainless Steel Tie	-	118 (17)	-	489 (7830)	0.12 (500)
12	Stainless Steel Triangle Tie	-	118 (17)	-	489 (7830)	0.12 (500)
13	Exterior Film ¹	-	-	R-0.2 (0.03 RSI)	-	-

¹ Value selected from table 1, p. 26.1 of 2009 ASHRAE Handbook – Fundamentals depending on surface orientation

Detail 5.1.72 Exterior Insulated 3 5/8" x 1 5/8" Steel Stud (16" o.c.) Wall Assembly with Hohmann & Barnard Masonry Carbon Steel HB-213 2X Anchor Supporting Brick Veneer – Clear Wall

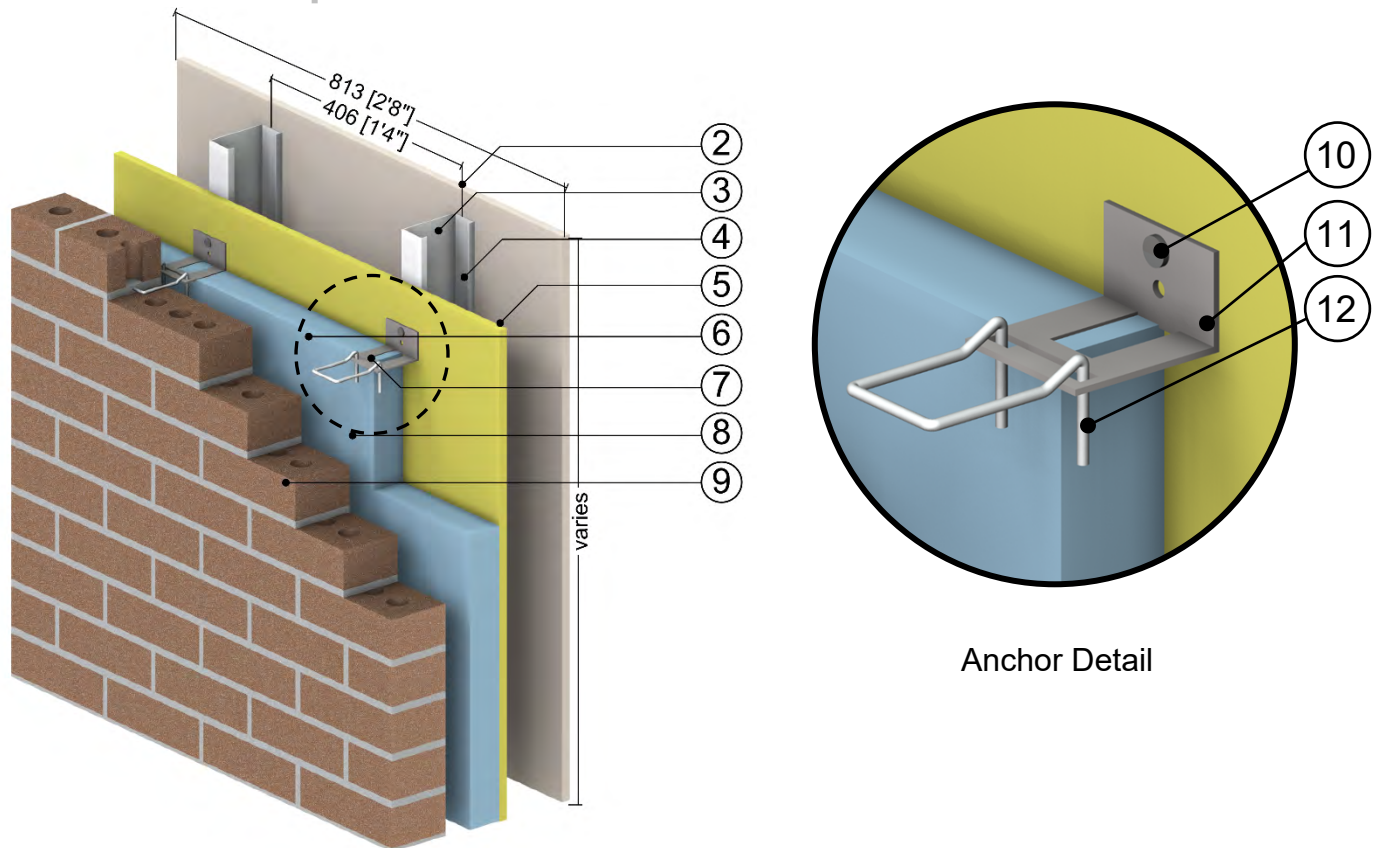

ID	Component	Thickness Inches (mm)	Conductivity Btu-in / ft ² -hr-°F (W/m K)	Nominal Resistance hr-ft ² -°F/Btu (m ² K/W)	Density lb/ft ³ (kg/m ³)	Specific Heat Btu/lb-°F (J/kg K)
1	Interior Film ¹	-	-	R-0.7 (0.12 RSI)	-	-
2	Gypsum Board	1/2" (13)	1.1 (0.16)	R-0.5 (0.08 RSI)	50 (800)	0.26 (1090)
3	Air in Stud Cavity	3 5/8" (92)	-	R-0.9 (0.16 RSI)	0.075 (1.2)	0.24 (1000)
4	3 5/8" x 1 5/8" Steel Studs	18 Gauge	430 (62)	-	489 (7830)	0.12 (500)
5	Exterior Sheathing	5/8" (16)	1.1 (0.16)	R-0.6 (0.10 RSI)	50 (800)	0.26 (1090)
6	Exterior Mineral Wool Insulation	1" to 4" (25 to 102)	0.24 (0.034)	R-4.2 to R-16.8 (0.74 to 2.96 RSI)	4 (64)	0.20 (850)
7	Brick Tie	1" to 4" (25 to 102)	Varies	-	-	-
8	Vented Air Cavity	1.5" (38)	-	R-0.4 (0.07 RSI)	0.075 (1.2)	0.24 (1000)
9	Brick Veneer	3 5/8" (92)	5.4 (0.78)	-	120 (1920)	0.19 (720)
10	Steel Fasteners	0.28" (7) Ø	347 (50)	-	489 (7830)	0.12 (500)
11	Steel Veneer Anchor	-	347 (50)	-	489 (7830)	0.12 (500)
12	Steel Wire Pintle	-	347 (50)	-	489 (7830)	0.12 (500)
13	Exterior Film ¹	-	-	R-0.2 (0.03 RSI)	-	-

¹ Value selected from table 1, p. 26.1 of 2009 ASHRAE Handbook – Fundamentals depending on surface orientation

Detail 5.1.73

Exterior Insulated 3 5/8" x 1 5/8" Steel Stud (16" o.c.) Wall Assembly with Hohmann & Barnard Masonry Stainless Steel HB-213 2X Anchor Supporting Brick Veneer – Clear Wall

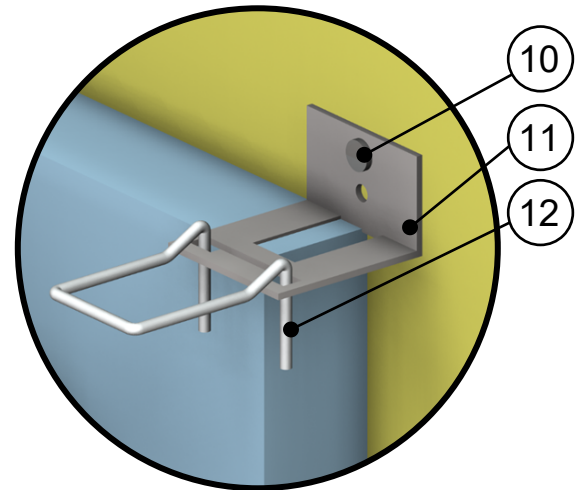
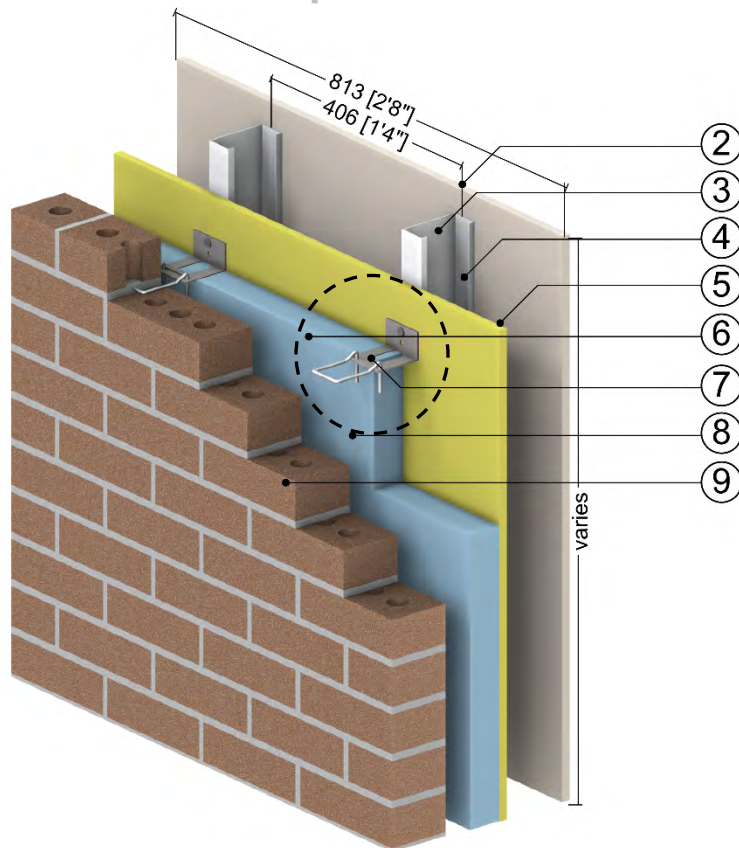

Anchor Detail

ID	Component	Thickness Inches (mm)	Conductivity Btu-in / ft ² -hr-°F (W/m K)	Nominal Resistance hr-ft ² -°F/Btu (m ² K/W)	Density lb/ft ³ (kg/m ³)	Specific Heat Btu/lb-°F (J/kg K)
1	Interior Film ¹	-	-	R-0.7 (0.12 RSI)	-	-
2	Gypsum Board	1/2" (13)	1.1 (0.16)	R-0.5 (0.08 RSI)	50 (800)	0.26 (1090)
3	Air in Stud Cavity	3 5/8" (92)	-	R-0.9 (0.16 RSI)	0.075 (1.2)	0.24 (1000)
4	3 5/8" x 1 5/8" Steel Studs	18 Gauge	430 (62)	-	489 (7830)	0.12 (500)
5	Exterior Sheathing	5/8" (16)	1.1 (0.16)	R-0.6 (0.10 RSI)	50 (800)	0.26 (1090)
6	Exterior Mineral Wool Insulation	1" to 4" (25 to 102)	0.24 (0.034)	R-4.2 to R-16.8 (0.74 to 2.96 RSI)	4 (64)	0.20 (850)
7	Brick Tie	1" to 4" (25 to 102)	Varies	-	-	-
8	Vented Air Cavity	1.5" (38)	-	R-0.4 (0.07 RSI)	0.075 (1.2)	0.24 (1000)
9	Brick Veneer	3 5/8" (92)	5.4 (0.78)	-	120 (1920)	0.19 (720)
10	Stainless Steel Fasteners	0.28" (7) Ø	118 (17)	-	489 (7830)	0.12 (500)
11	Stainless Steel Veneer Anchor	-	118 (17)	-	489 (7830)	0.12 (500)
12	Stainless Steel Wire Pintle	-	118 (17)	-	489 (7830)	0.12 (500)
13	Exterior Film ¹	-	-	R-0.2 (0.03 RSI)	-	-

¹ Value selected from table 1, p. 26.1 of 2009 ASHRAE Handbook – Fundamentals depending on surface orientation

Detail 5.1.74 Exterior Insulated 3 5/8" x 1 5/8" Steel Stud (16" o.c.) Wall Assembly with Hohmann & Barnard Masonry Carbon Steel HB-200-X Anchor Supporting Brick Veneer – Clear Wall

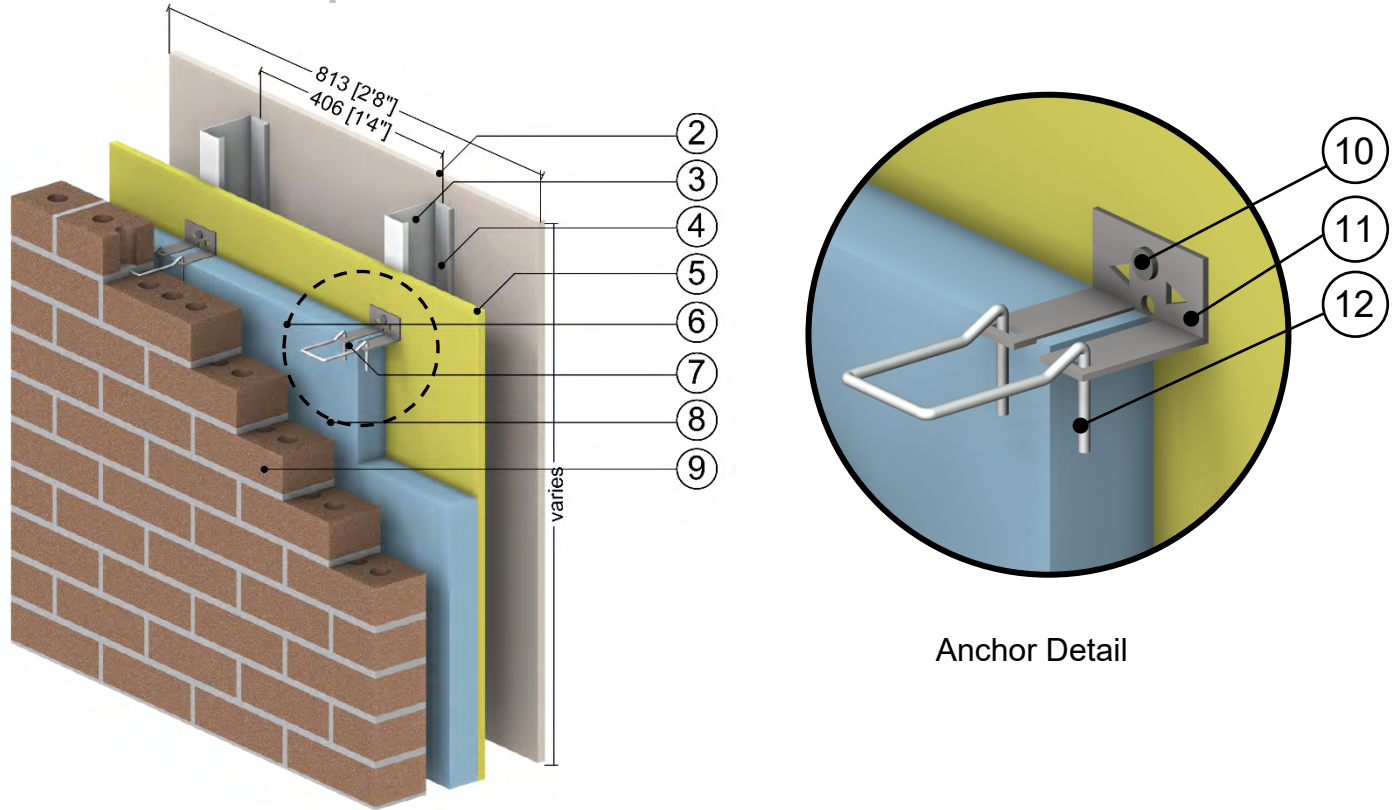

ID	Component	Thickness Inches (mm)	Conductivity Btu-in / ft ² -hr-°F (W/m K)	Nominal Resistance hr-ft ² -°F/Btu (m ² K/W)	Density lb/ft ³ (kg/m ³)	Specific Heat Btu/lb-°F (J/kg K)
1	Interior Film ¹	-	-	R-0.7 (0.12 RSI)	-	-
2	Gypsum Board	1/2" (13)	1.1 (0.16)	R-0.5 (0.08 RSI)	50 (800)	0.26 (1090)
3	Air in Stud Cavity	3 5/8" (92)	-	R-0.9 (0.16 RSI)	0.075 (1.2)	0.24 (1000)
4	3 5/8" x 1 5/8" Steel Studs	18 Gauge	430 (62)	-	489 (7830)	0.12 (500)
5	Exterior Sheathing	5/8" (16)	1.1 (0.16)	R-0.6 (0.10 RSI)	50 (800)	0.26 (1090)
6	Exterior Mineral Wool Insulation	1" to 4" (25 to 102)	0.24 (0.034)	R-4.2 to R-16.8 (0.74 to 2.96 RSI)	4 (64)	0.20 (850)
7	Brick Tie	1" to 4" (25 to 102)	Varies	-	-	-
8	Vented Air Cavity	1.5" (38)	-	R-0.4 (0.07 RSI)	0.075 (1.2)	0.24 (1000)
9	Brick Veneer	3 5/8" (92)	5.4 (0.78)	-	120 (1920)	0.19 (720)
10	Steel Fasteners	0.31" (8) Ø	347 (50)	-	489 (7830)	0.12 (500)
11	Steel Veneer Anchor	-	347 (50)	-	489 (7830)	0.12 (500)
12	Steel Wire Pintel	-	347 (50)	-	489 (7830)	0.12 (500)
13	Exterior Film ¹	-	-	R-0.2 (0.03 RSI)	-	-

¹ Value selected from table 1, p. 26.1 of 2009 ASHRAE Handbook – Fundamentals depending on surface orientation

Detail 5.1.75

Exterior Insulated 3 5/8" x 1 5/8" Steel Stud (16" o.c.) Wall Assembly with Hohmann & Barnard Masonry Stainless Steel HB-200-X Anchor Supporting Brick Veneer – Clear Wall

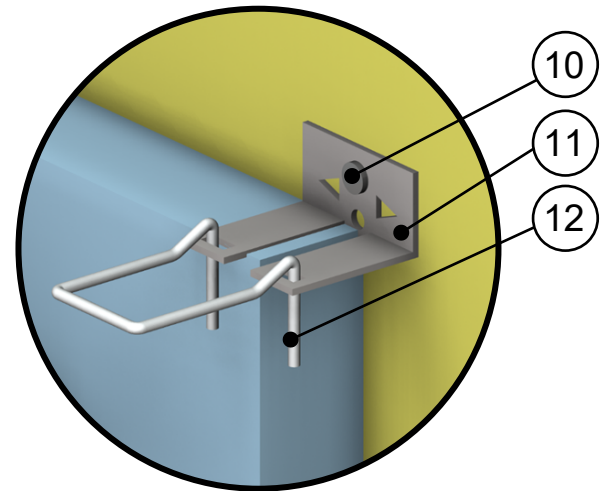
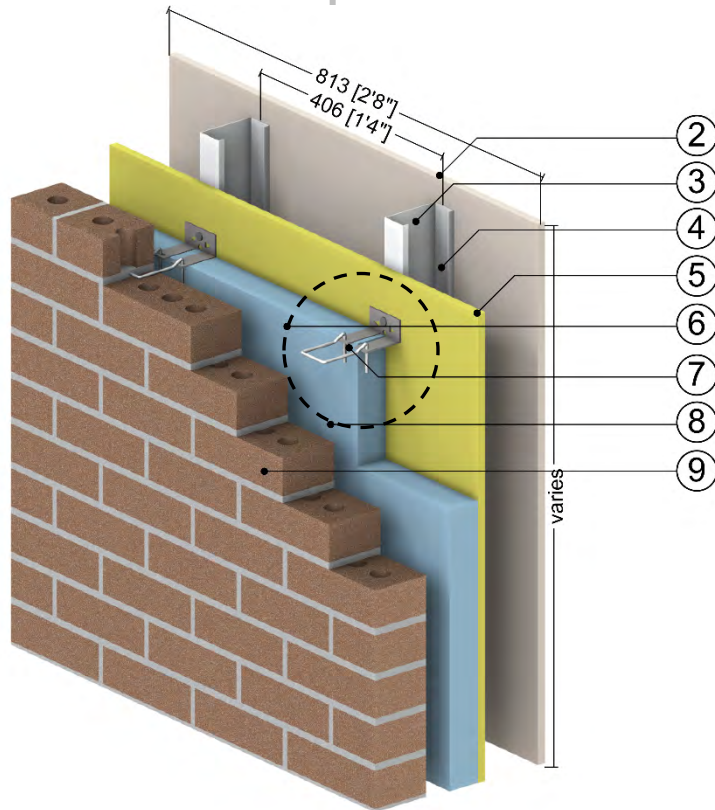

Anchor Detail

ID	Component	Thickness Inches (mm)	Conductivity Btu-in / ft ² -hr-°F (W/m K)	Nominal Resistance hr-ft ² -°F/Btu (m ² K/W)	Density lb/ft ³ (kg/m ³)	Specific Heat Btu/lb-°F (J/kg K)
1	Interior Film ¹	-	-	R-0.7 (0.12 RSI)	-	-
2	Gypsum Board	1/2" (13)	1.1 (0.16)	R-0.5 (0.08 RSI)	50 (800)	0.26 (1090)
3	Air in Stud Cavity	3 5/8" (92)	-	R-0.9 (0.16 RSI)	0.075 (1.2)	0.24 (1000)
4	3 5/8" x 1 5/8" Steel Studs	18 Gauge	430 (62)	-	489 (7830)	0.12 (500)
5	Exterior Sheathing	5/8" (16)	1.1 (0.16)	R-0.6 (0.10 RSI)	50 (800)	0.26 (1090)
6	Exterior Mineral Wool Insulation	1" to 4" (25 to 102)	0.24 (0.034)	R-4.2 to R-16.8 (0.74 to 2.96 RSI)	4 (64)	0.20 (850)
7	Brick Tie	1" to 4" (25 to 102)	Varies	-	-	-
8	Vented Air Cavity	1.5" (38)	-	R-0.4 (0.07 RSI)	0.075 (1.2)	0.24 (1000)
9	Brick Veneer	3 5/8" (92)	5.4 (0.78)	-	120 (1920)	0.19 (720)
10	Stainless Steel Fasteners	0.31" (8) Ø	118 (17)	-	489 (7830)	0.12 (500)
11	Stainless Steel Veneer Anchor	-	118 (17)	-	489 (7830)	0.12 (500)
12	Stainless Steel Wire Pintle	-	118 (17)	-	489 (7830)	0.12 (500)
13	Exterior Film ¹	-	-	R-0.2 (0.03 RSI)	-	-

¹ Value selected from table 1, p. 26.1 of 2009 ASHRAE Handbook – Fundamentals depending on surface orientation

Detail 5.1.76

Exterior Insulated 3 5/8" x 1 5/8" Steel Stud (16" o.c.) Wall Assembly with Hohmann & Barnard Masonry Carbon Steel BL-407 Anchor Supporting Brick Veneer – Clear Wall

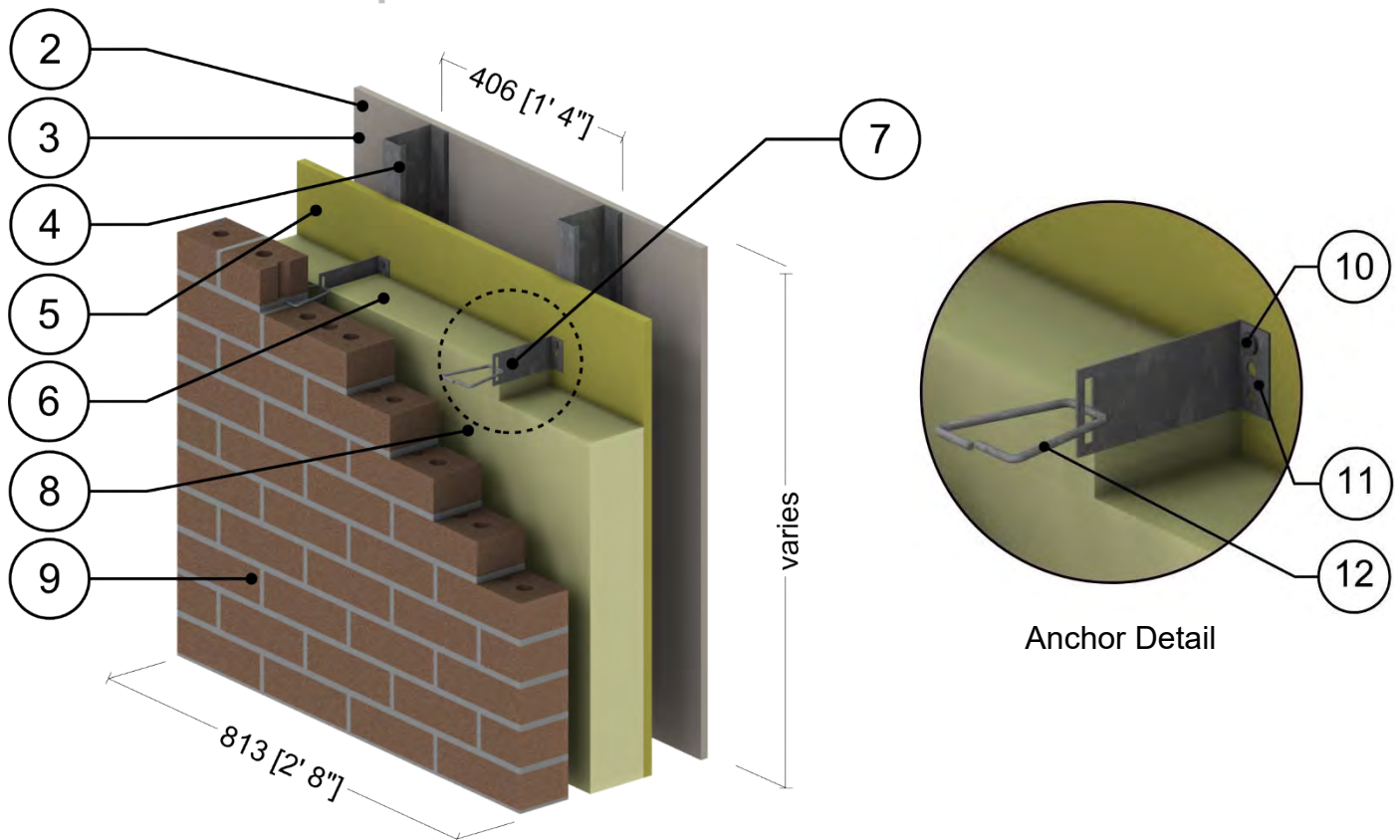

ID	Component	Thickness Inches (mm)	Conductivity Btu-in / ft ² -hr-°F (W/m K)	Nominal Resistance hr-ft ² -°F/Btu (m ² K/W)	Density lb/ft ³ (kg/m ³)	Specific Heat Btu/lb-°F (J/kg K)
1	Interior Film ¹	-	-	R-0.7 (0.12 RSI)	-	-
2	Gypsum Board	1/2" (13)	1.1 (0.16)	R-0.5 (0.08 RSI)	50 (800)	0.26 (1090)
3	Air in Stud Cavity	3 5/8" (92)	-	R-0.9 (0.16 RSI)	0.075 (1.2)	0.24 (1000)
4	3 5/8" x 1 5/8" Steel Studs	18 Gauge	430 (62)	-	489 (7830)	0.12 (500)
5	Exterior Sheathing	5/8" (16)	1.1 (0.16)	R-0.6 (0.10 RSI)	50 (800)	0.26 (1090)
6	Exterior Mineral Wool Insulation	Varies	0.24 (0.034)	R-4.2 to R-29.4 (0.74 to 5.18 RSI)	4 (64)	0.20 (850)
7	Brick Tie	1" to 7" (25 to 178)	Varies	-	-	-
8	Vented Air Cavity	1.5" (38)	-	R-0.4 (0.07 RSI)	0.075 (1.2)	0.24 (1000)
9	Brick Veneer	3 5/8" (92)	5.4 (0.78)	-	120 (1920)	0.19 (720)
10	Steel Fasteners	0.28" (7) Ø	347 (50)	-	489 (7830)	0.12 (500)
11	Steel Veneer Anchor	-	347 (50)	-	489 (7830)	0.12 (500)
12	Steel Wire Pintle	-	347 (50)	-	489 (7830)	0.12 (500)
13	Exterior Film ¹	-	-	R-0.2 (0.03 RSI)	-	-

¹ Value selected from table 1, p. 26.1 of 2009 ASHRAE Handbook – Fundamentals depending on surface orientation

Detail 5.1.77 Exterior Insulated 3 5/8" x 1 5/8" Steel Stud (16" o.c.) Wall Assembly with Hohmann & Barnard Masonry Stainless Steel BL-407 Anchor Supporting Brick Veneer – Clear Wall

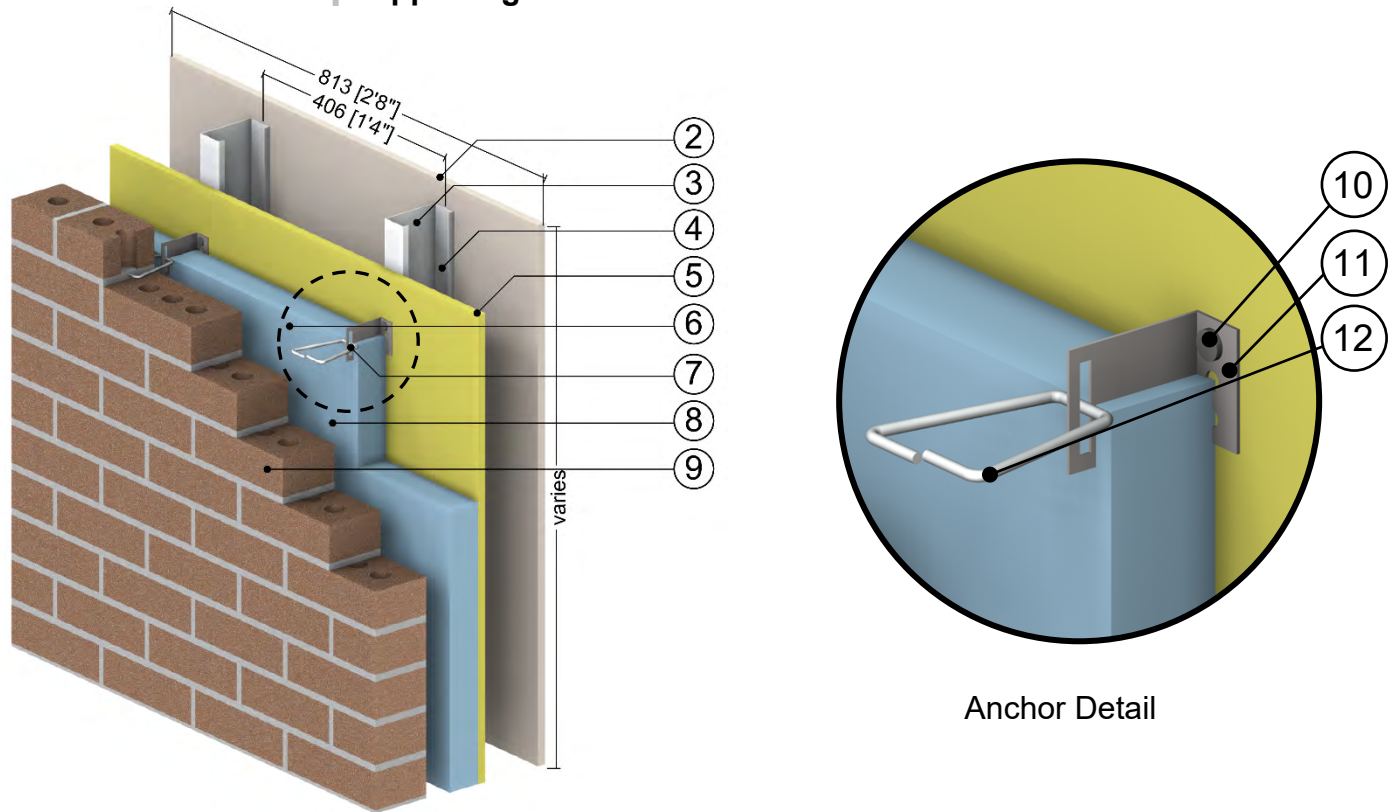

ID	Component	Thickness Inches (mm)	Conductivity Btu-in / ft ² -hr-°F (W/m K)	Nominal Resistance hr-ft ² -°F/Btu (m ² K/W)	Density lb/ft ³ (kg/m ³)	Specific Heat Btu/lb-°F (J/kg K)
1	Interior Film ¹	-	-	R-0.7 (0.12 RSI)	-	-
2	Gypsum Board	1/2" (13)	1.1 (0.16)	R-0.5 (0.08 RSI)	50 (800)	0.26 (1090)
3	Air in Stud Cavity	3 5/8" (92)	-	R-0.9 (0.16 RSI)	0.075 (1.2)	0.24 (1000)
4	3 5/8" x 1 5/8" Steel Studs	18 Gauge	430 (62)	-	489 (7830)	0.12 (500)
5	Exterior Sheathing	5/8" (16)	1.1 (0.16)	R-0.6 (0.10 RSI)	50 (800)	0.26 (1090)
6	Exterior Mineral Wool Insulation	1" to 4" (25 to 102)	0.24 (0.034)	R-4.2 to R-16.8 (0.74 to 2.96 RSI)	4 (64)	0.20 (850)
7	Brick Tie	1" to 4" (25 to 102)	Varies	-	-	-
8	Vented Air Cavity	1.5" (38)	-	R-0.4 (0.07 RSI)	0.075 (1.2)	0.24 (1000)
9	Brick Veneer	3 5/8" (92)	5.4 (0.78)	-	120 (1920)	0.19 (720)
10	Stainless Steel Fasteners	0.28" (7) Ø	118 (17)	-	489 (7830)	0.12 (500)
11	Stainless Steel Veneer Anchor	-	118 (17)	-	489 (7830)	0.12 (500)
12	Stainless Steel Wire Pintle	-	118 (17)	-	489 (7830)	0.12 (500)
13	Exterior Film ¹	-	-	R-0.2 (0.03 RSI)	-	-

¹ Value selected from table 1, p. 26.1 of 2009 ASHRAE Handbook – Fundamentals depending on surface orientation

Detail 5.1.78

Exterior and Interior Insulated 6" x 1 5/8" Steel Stud (16" o.c. and 24" o.c.) Wall Assembly with Stainless Steel Brick Anchors Supporting Brick Veneer and R-20 Batt Insulation in Stud Cavity – Clear Wall

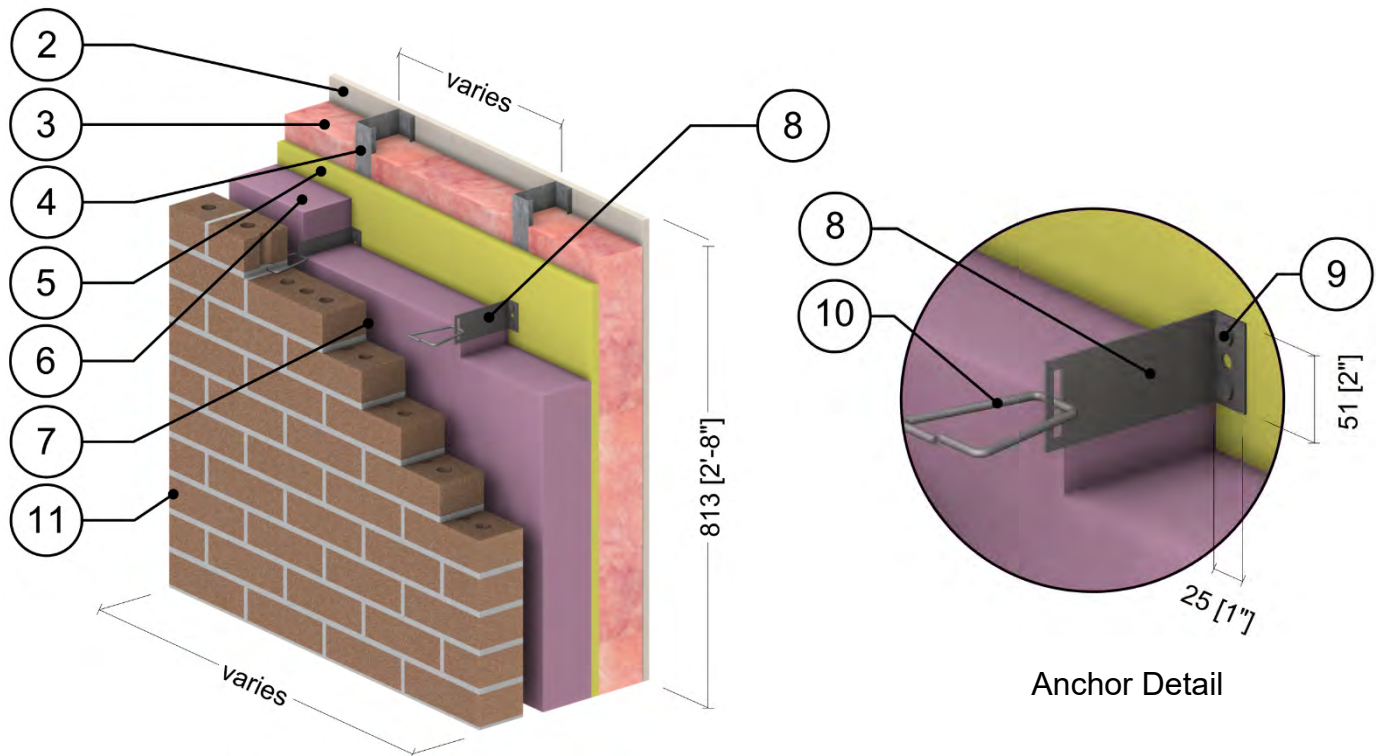

ID	Component	Thickness Inches (mm)	Conductivity Btu-in / ft ² ·hr·°F (W/m K)	Nominal Resistance hr·ft ² ·°F/Btu (m ² K/W)	Density lb/ft ³ (kg/m ³)	Specific Heat Btu/lb·°F (J/kg K)
1	Interior Films ¹	-	-	R-0.7 (0.12 RSI)	-	-
2	Gypsum Board	1/2" (13)	1.1 (0.16)	R-0.5 (0.08 RSI)	50 (800)	0.26 (1090)
3	Fiberglass Batt Insulation	6" (152)	0.30 (0.043)	R-20 (3.5 RSI)	0.55 (8.8)	0.17 (710)
4	6" x 1 5/8" Steel Studs	18 Gauge	430 (62)	-	489 (7830)	0.12 (500)
5	Exterior Sheathing	5/8" (16)	1.1 (0.16)	R-0.6 (0.10 RSI)	50 (800)	0.26 (1090)
6	Exterior Insulation	1" to 7" (25 to 178)	0.20 (0.029)	R-5 to R-35 (0.88 to 6.16 RSI)	1.8 (28)	0.29 (1220)
7	Vented Air Cavity	1 1/2" (38)	-	R-0.4 (0.07 RSI)	0.075 (1.2)	0.24 (1000)
8	Stainless Steel Veneer Anchor	Varies	118 (17)	-	500 (8000)	0.12 (500)
9	Stainless Steel Fasteners	0.28" (7) Ø	118 (17)	-	500 (8000)	0.12 (500)
10	Stainless Steel Wire Pintle	-	118 (17)	-	500 (8000)	0.12 (500)
11	Brick Veneer	3 5/8" (92)	5.4 (0.78)	-	120 (1920)	0.19 (720)
12	Exterior Film ¹	-	-	R-0.2 (0.03 RSI)	-	-

¹ Value selected from table 1, p. 26.1 of 2009 ASHRAE Handbook – Fundamentals depending on surface orientation

Detail 5.1.79

Exterior and Interior Insulated 6" x 1 5/8" Steel Stud (16" o.c. and 24" o.c.) Wall Assembly with Steel Brick Anchors Supporting Brick Veneer and R-20 Batt Insulation in Stud Cavity – Clear Wall

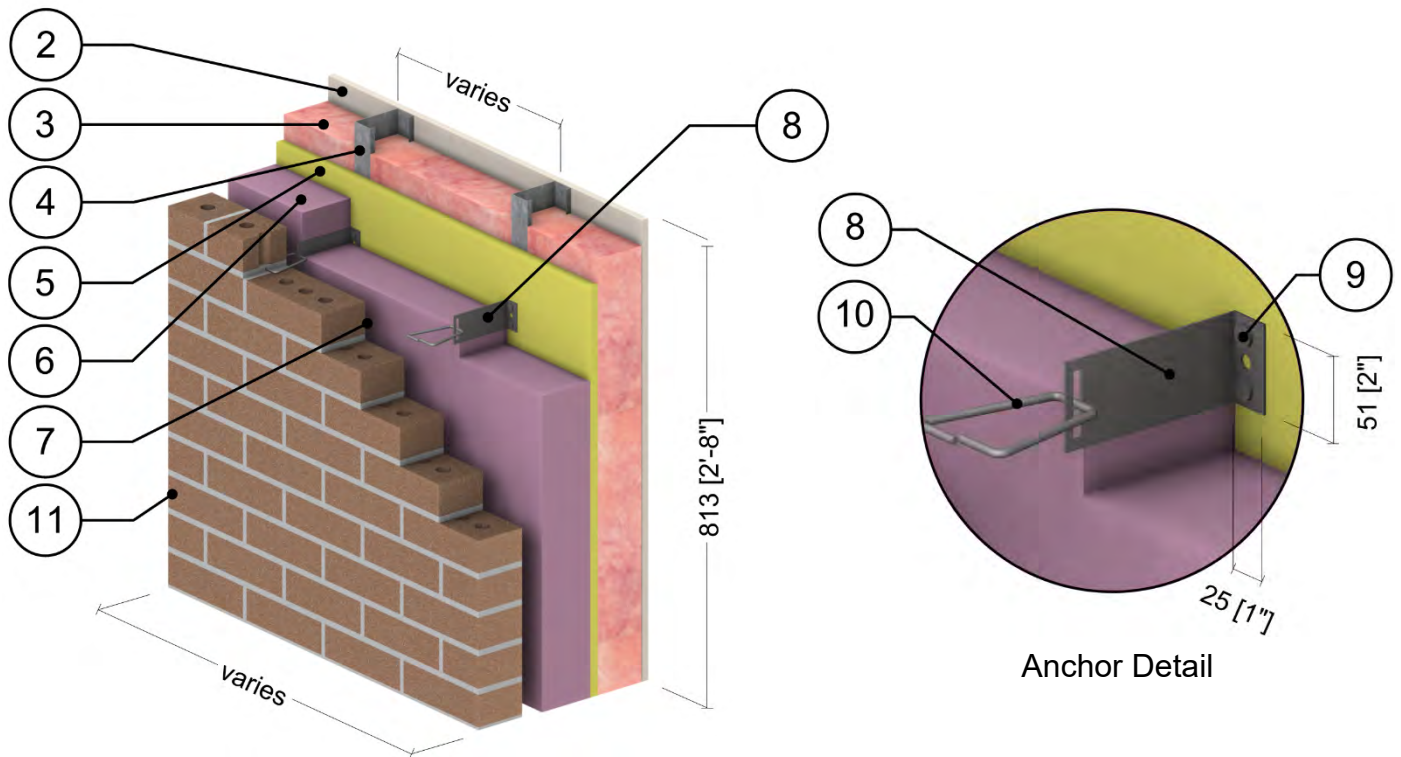

ID	Component	Thickness Inches (mm)	Conductivity Btu-in / ft ² -hr-°F (W/m K)	Nominal Resistance hr-ft ² -°F/Btu (m ² K/W)	Density lb/ft ³ (kg/m ³)	Specific Heat Btu/lb-°F (J/kg K)
1	Interior Films ¹	-	-	R-0.7 (0.12 RSI)	-	-
2	Gypsum Board	1/2" (13)	1.1 (0.16)	R-0.5 (0.08 RSI)	50 (800)	0.26 (1090)
3	Fiberglass Batt Insulation	6" (152)	0.30 (0.043)	R-20 (3.5 RSI)	0.55 (8.8)	0.17 (710)
4	6" x 1 5/8" Steel Studs	18 Gauge	430 (62)	-	489 (7830)	0.12 (500)
5	Exterior Sheathing	5/8" (16)	1.1 (0.16)	R-0.6 (0.10 RSI)	50 (800)	0.26 (1090)
6	Rigid Insulation	Varies	0.20 (0.029)	R-20 to R-35 (3.52 to 6.16 RSI)	Varies	0.29 (1220)
7	Vented Air Cavity	1 1/2" (38)	-	R-0.4 (0.07 RSI)	0.075 (1.2)	0.24 (1000)
8	Galvanized Steel Veneer Anchor	Varies	430 (62)	-	489 (7830)	0.12 (500)
9	Galvanized Steel Fasteners	0.28" (7) Ø	430 (62)	-	489 (7830)	0.12 (500)
10	Galvanized Steel Wire Pintle	-	430 (62)	-	489 (7830)	0.12 (500)
11	Brick Veneer	3 5/8" (92)	5.4 (0.78)	-	120 (1920)	0.19 (720)
12	Exterior Film ¹	-	-	R-0.2 (0.03 RSI)	-	-

¹ Value selected from table 1, p. 26.1 of 2009 ASHRAE Handbook – Fundamentals depending on surface orientation

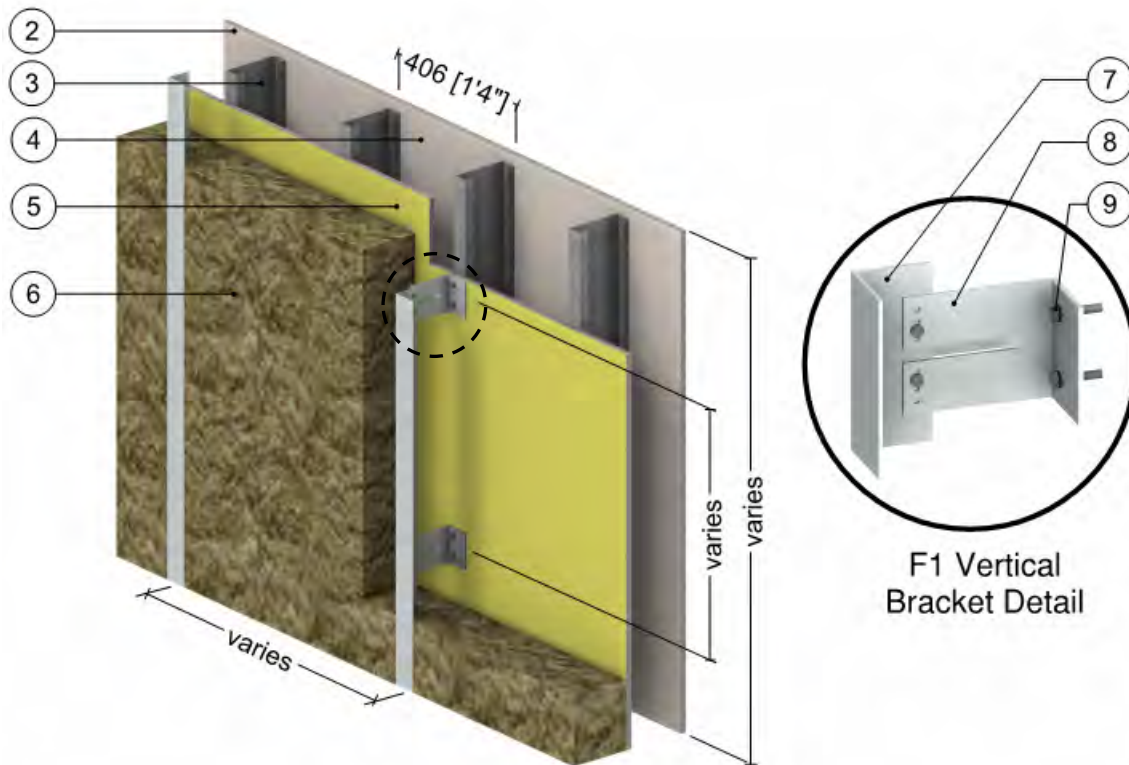
Detail 5.1.80**Exterior Insulated 6" x 1 5/8" Steel Stud (16" o.c.) Wall Assembly with ECO Cladding Alpha Vci Vertical System – Clear Wall**

ID	Component	Thickness Inches (mm)	Conductivity Btu-in / ft ² ·hr·°F (W/m K)	Nominal Resistance hr-ft ² ·°F/Btu (m ² K/W)	Density lb/ft ³ (kg/m ³)	Specific Heat Btu/lb·°F (J/kg K)
1	Interior Film ¹	-	-	R-0.7 (0.12 RSI)	-	-
2	Gypsum Board	1/2" (13)	1.1 (0.16)	R-0.5 (0.08 RSI)	50 (800)	0.26 (1090)
3	6" x 1 5/8" Steel Studs	18 Gauge	430 (62)	-	489 (7830)	0.12 (500)
4	Air in Stud Cavity	6" (152)	-	R-0.9 (0.16 RSI)	0.075 (1.2)	0.24 (1000)
5	Exterior Sheathing	5/8" (15)	1.1 (0.16)	R-0.5 (0.08 RSI)	50 (800)	0.26 (1090)
6	Exterior Mineral Wool Insulation	2" to 6" (51 to 152)	0.24 (0.034)	R-8.4 to R-25.2 (1.48 RSI to 4.44 RSI)	4 (64)	0.20 (850)
7	L Angle Aluminum 6063	-	1450 (209)	-	168 (2700)	0.22 (900)
8	ECO Cladding Alpha V Bracket Aluminum 6063	-	1450 (209)	-	168 (2700)	0.22 (900)
9	#14 Stainless Steel Fasteners	1/4" (6) ∅	118 (17)	-	500 (8000)	0.13 (530)
10	Generic Cladding with 1" (25mm) vented air space is incorporated into exterior heat transfer coefficient					
11	Exterior Film ¹	-	-	R-0.7 (0.12 RSI)	-	-

¹ Value selected from table 1, p. 26.1 of 2009 ASHRAE Handbook – Fundamentals depending on surface orientation

Detail 5.1.81

Exterior and Interior Insulated 6" x 1 5/8" Steel Stud (16" o.c.) Wall Assembly with ECO Cladding Alpha Vci Vertical System and R-19 Batt Insulation in Stud Cavity – Clear Wall

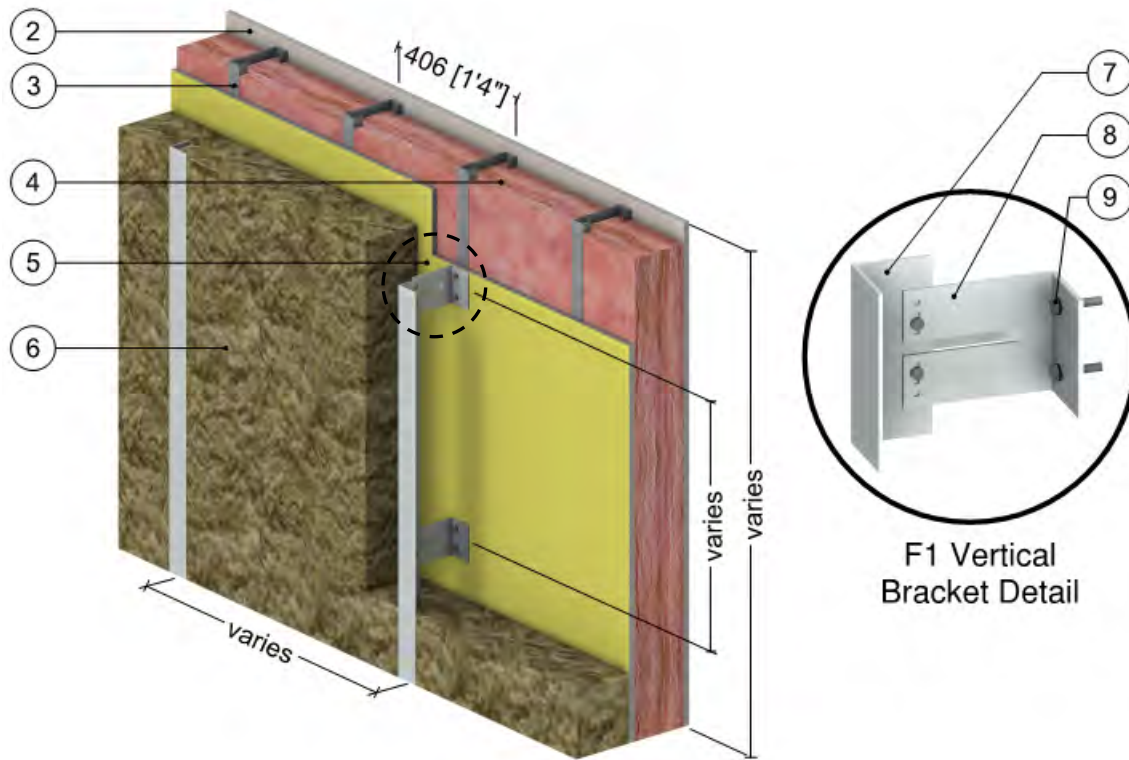

ID	Component	Thickness Inches (mm)	Conductivity Btu-in / ft ² ·hr·°F (W/m K)	Nominal Resistance hr·ft ² ·°F/Btu (m ² K/W)	Density lb/ft ³ (kg/m ³)	Specific Heat Btu/lb·°F (J/kg K)
1	Interior Film ¹	-	-	R-0.7 (0.12 RSI)	-	-
2	Gypsum Board	1/2" (13)	1.1 (0.16)	R-0.5 (0.08 RSI)	50 (800)	0.26 (1090)
3	6" x 1 5/8" Steel Studs	18 Gauge	430 (62)	-	489 (7830)	0.12 (500)
4	Fiberglass Batt Insulation	6" (152)	-	R-19 (3.35 RSI)	0.9 (14)	0.17 (710)
5	Exterior Sheathing	5/8" (15)	1.1 (0.16)	R-0.5 (0.08 RSI)	50 (800)	0.26 (1090)
6	Exterior Mineral Wool Insulation	2" to 6" (51 to 152)	0.24 (0.034)	R-8.4 to R-25.2 (1.48 RSI to 4.44 RSI)	4 (64)	0.20 (850)
7	L Angle Aluminum 6063	-	1450 (209)	-	168 (2700)	0.22 (900)
8	ECO Cladding Alpha V Bracket Aluminum 6063	-	1450 (209)	-	168 (2700)	0.22 (900)
9	#14 Stainless Steel Fasteners	1/4" (6) ∅	118 (17)	-	500 (8000)	0.13 (530)
10	Generic Cladding with 1" (25mm) vented air space is incorporated into exterior heat transfer coefficient					
11	Exterior Film ¹	-	-	R-0.7 (0.12 RSI)	-	-

¹ Value selected from table 1, p. 26.1 of 2009 ASHRAE Handbook – Fundamentals depending on surface orientation

Detail 5.1.82 Exterior Insulated 6" x 1 5/8" Steel Stud (16" o.c.) Wall Assembly with ECO Cladding Alpha Hci Horizontal System – Clear Wall

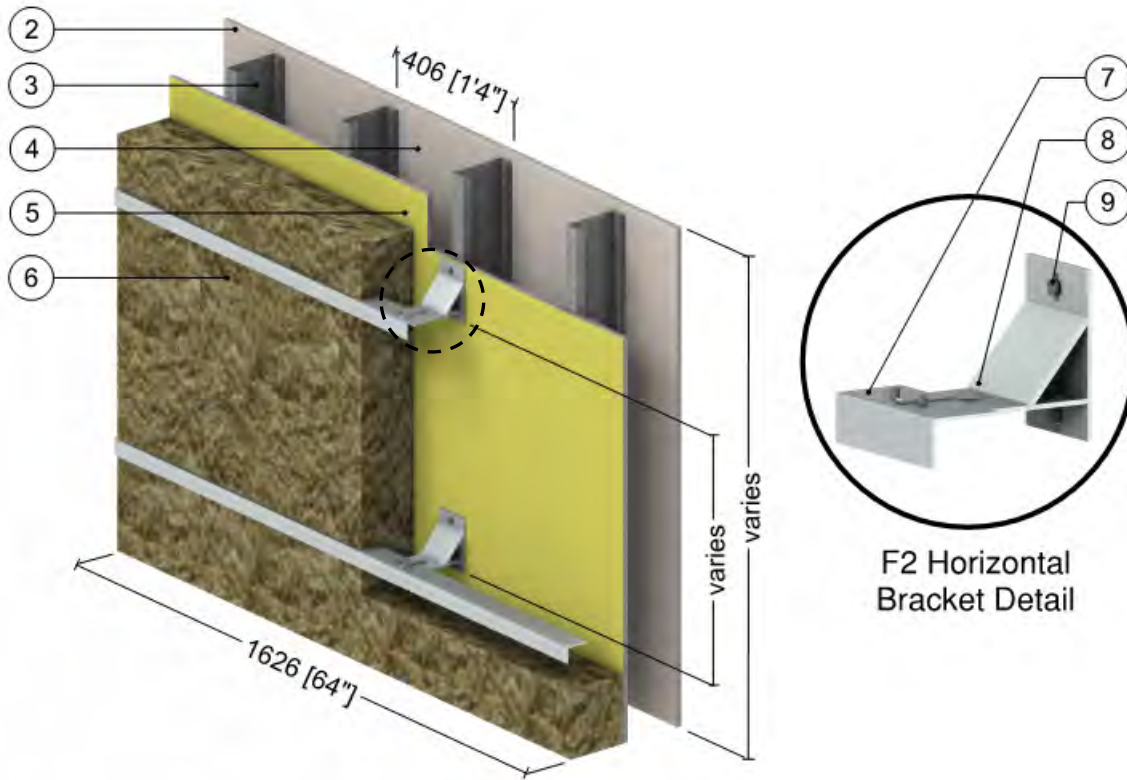

ID	Component	Thickness Inches (mm)	Conductivity Btu-in / ft ² ·hr·°F (W/m K)	Nominal Resistance hr·ft ² ·°F/Btu (m ² K/W)	Density lb/ft ³ (kg/m ³)	Specific Heat Btu/lb·°F (J/kg K)
1	Interior Film ¹	-	-	R-0.7 (0.12 RSI)	-	-
2	Gypsum Board	1/2" (13)	1.1 (0.16)	R-0.5 (0.08 RSI)	50 (800)	0.26 (1090)
3	6" x 1 5/8" Steel Studs	18 Gauge	430 (62)	-	489 (7830)	0.12 (500)
4	Air in Stud Cavity	6" (152)	-	R-0.9 (0.16 RSI)	0.075 (1.2)	0.24 (1000)
5	Exterior Sheathing	5/8" (15)	1.1 (0.16)	R-0.5 (0.08 RSI)	50 (800)	0.26 (1090)
6	Exterior Mineral Wool Insulation	2" to 6" (51 to 152)	0.24 (0.034)	R-8.4 to R-25.2 (1.48 RSI to 4.44 RSI)	4 (64)	0.20 (850)
7	L Angle Aluminum 6063	-	1450 (209)	-	168 (2700)	0.22 (900)
8	ECO Cladding Alpha H Bracket Aluminum 6063	-	1450 (209)	-	168 (2700)	0.22 (900)
9	#14 Stainless Steel Fasteners	1/4" (6) ∅	118 (17)	-	500 (8000)	0.13 (530)
10	Generic Cladding with 1" (25mm) vented air space is incorporated into exterior heat transfer coefficient					
11	Exterior Film ¹	-	-	R-0.7 (0.12 RSI)	-	-

¹ Value selected from table 1, p. 26.1 of 2009 ASHRAE Handbook – Fundamentals depending on surface orientation

Detail 5.1.83

Exterior and Interior Insulated 6" x 1 5/8" Steel Stud (16" o.c.) Wall Assembly with ECO Cladding Alpha Hci Horizontal System and R-19 Batt Insulation in Stud Cavity – Clear Wall

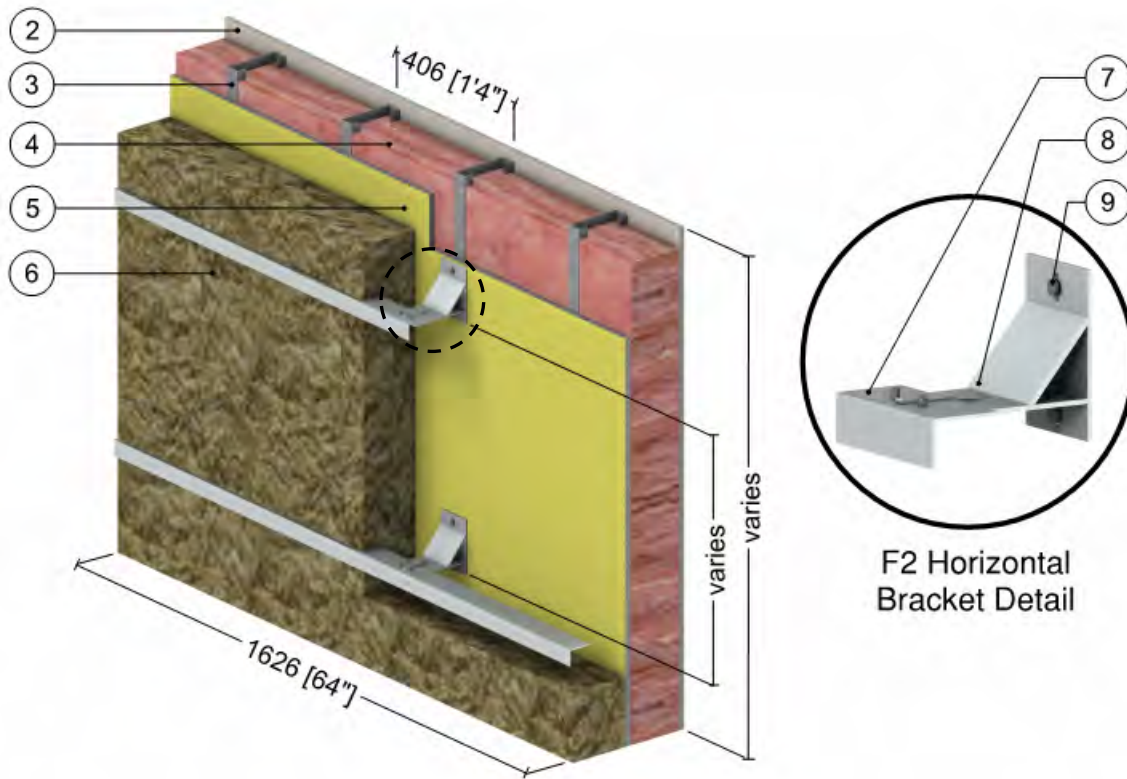

ID	Component	Thickness Inches (mm)	Conductivity Btu·in / ft ² ·hr·°F (W/m K)	Nominal Resistance hr·ft ² ·°F/Btu (m ² K/W)	Density lb/ft ³ (kg/m ³)	Specific Heat Btu/lb·°F (J/kg K)
1	Interior Film ¹	-	-	R-0.7 (0.12 RSI)	-	-
2	Gypsum Board	1/2" (13)	1.1 (0.16)	R-0.5 (0.08 RSI)	50 (800)	0.26 (1090)
3	6" x 1 5/8" Steel Studs	18 Gauge	430 (62)	-	489 (7830)	0.12 (500)
4	Fiberglass Batt Insulation	6" (152)	-	R-19 (3.35 RSI)	0.9 (14)	0.17 (710)
5	Exterior Sheathing	5/8" (15)	1.1 (0.16)	R-0.5 (0.08 RSI)	50 (800)	0.26 (1090)
6	Exterior Mineral Wool Insulation	2" to 6" (51 to 152)	0.24 (0.034)	R-8.4 to R-25.2 (1.48 RSI to 4.44 RSI)	4 (64)	0.20 (850)
7	L Angle Aluminum 6063	-	1450 (209)	-	168 (2700)	0.22 (900)
8	ECO Cladding Alpha H Bracket Aluminum 6063	-	1450 (209)	-	168 (2700)	0.22 (900)
9	#14 Stainless Steel Fasteners	1/4" (6) ∅	118 (17)	-	500 (8000)	0.13 (530)
10	Generic Cladding with 1" (25mm) vented air space is incorporated into exterior heat transfer coefficient					
11	Exterior Film ¹	-	-	R-0.7 (0.12 RSI)	-	-

¹ Value selected from table 1, p. 26.1 of 2009 ASHRAE Handbook – Fundamentals depending on surface orientation

Detail 5.1.84

Exterior Insulated 3 5/8" x 1 5/8" Steel Stud (16" O.C.) Wall Assembly with Armadillo FRR Horizontal Z-Girts Supporting Cladding – Clear Wall

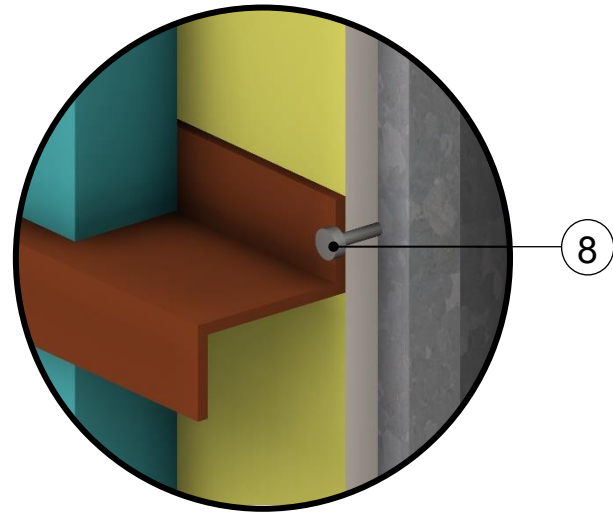
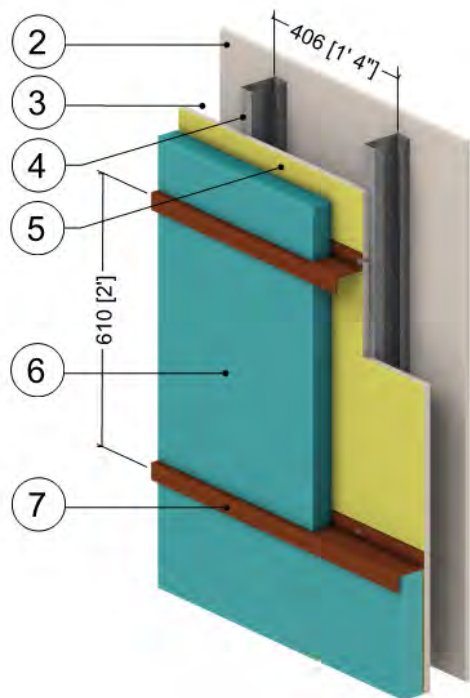

FRR Girt Detail

ID	Component	Thickness Inches (mm)	Conductivity Btu·in / ft ² ·hr·°F (W/m K)	Nominal Resistance hr·ft ² ·°F/Btu (m ² K/W)	Density lb/ft ³ (kg/m ³)	Specific Heat Btu/lb·°F (J/kg K)
1	Interior Film ¹	-	-	R-0.7 (0.12 RSI)	-	-
2	Gypsum Board	1/2" (13)	1.1 (0.16)	R-0.5 (0.08 RSI)	50 (800)	0.26 (1090)
3	Air Cavity	3 5/8" (92)	-	R-0.9 (0.16 RSI)	0.075 (1.2)	0.24 (1000)
4	3 5/8" x 1 5/8" Steel Studs	18 Gauge	430 (62)	-	489 (7830)	0.12 (500)
5	Exterior Sheathing	5/8" (16)	1.1 (0.16)	R-0.6 (0.10 RSI)	50 (800)	0.26 (1090)
6	Exterior Insulation	Varies	-	R-5.0 to R-35.0 (0.88 RSI to 6.16 RSI)	4 (64)	0.20 (850)
7	Armadillo FRR Girt	-	1.4 (0.2)	-	85 (5.3)	-
8	#12 Steel Fasteners (16" o.c.)	7/32" (5.5) ∅	347 (50)	-	489 (7830)	0.12 (500)
9	Generic Cladding with 1/2" (13mm) vented air space is incorporated into exterior heat transfer coefficient					
10	Exterior Film ¹	-	-	R-0.7 (0.12 RSI)	-	-

¹ Value selected from table 1, p. 26.1 of 2009 ASHRAE Handbook – Fundamentals depending on surface orientation

Detail 5.1.85

Exterior and Interior Insulated 3 5/8" x 1 5/8" Steel Stud (16" O.C.) Wall Assembly with Armadillo FRR Horizontal Z-Girts Supporting Cladding and R-13 Batt Insulation in Stud Cavity – Clear Wall

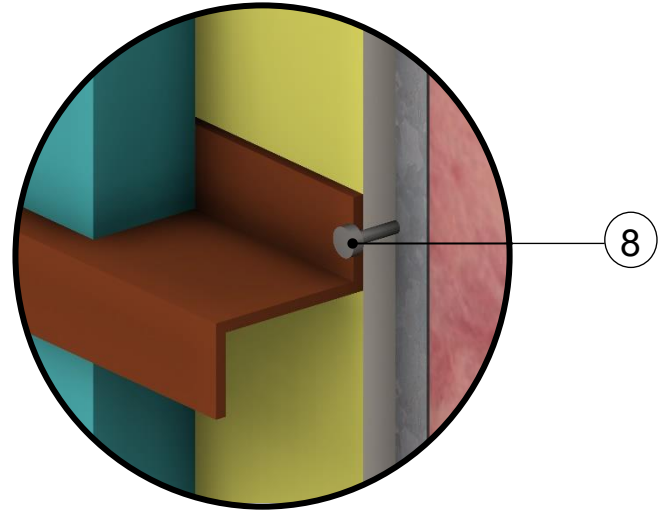
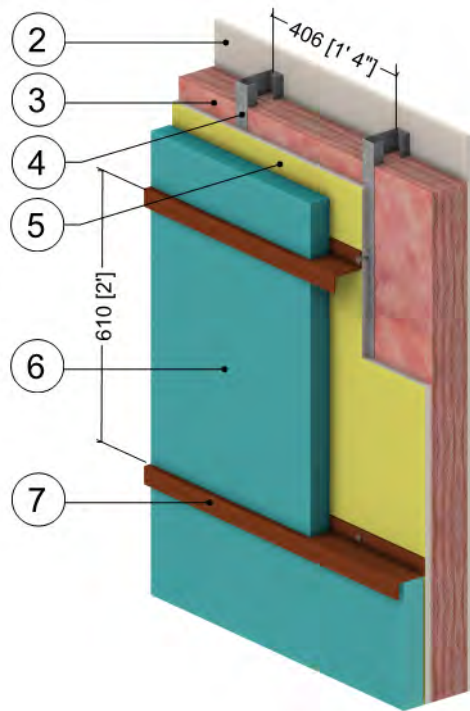

FRR Girt Detail

ID	Component	Thickness Inches (mm)	Conductivity Btu·in / ft ² ·hr·°F (W/m K)	Nominal Resistance hr·ft ² ·°F/Btu (m ² K/W)	Density lb/ft ³ (kg/m ³)	Specific Heat Btu/lb·°F (J/kg K)
1	Interior Film ¹	-	-	R-0.7 (0.12 RSI)	-	-
2	Gypsum Board	1/2" (13)	1.1 (0.16)	R-0.5 (0.08 RSI)	50 (800)	0.26 (1090)
3	Fiberglass Batt Insulation	3 5/8" (92)	-	R-13.0 (2.29 RSI)	4 (64)	0.20 (850)
4	3 5/8" x 1 5/8" Steel Studs	18 Gauge	430 (62)	-	489 (7830)	0.12 (500)
5	Exterior Sheathing	5/8" (16)	1.1 (0.16)	R-0.6 (0.10 RSI)	50 (800)	0.26 (1090)
6	Exterior Insulation	Varies	-	R-5.0 to R-35.0 (0.88 RSI to 6.16 RSI)	4 (64)	0.20 (850)
7	Armadillo FRR Girt	-	1.4 (0.2)	-	85 (5.3)	-
8	#12 Steel Fasteners (16" o.c.)	7/32" (5.5) ∅	347 (50)	-	489 (7830)	0.12 (500)
9	Generic Cladding with 1/2" (13mm) vented air space is incorporated into exterior heat transfer coefficient					
10	Exterior Film ¹	-	-	R-0.7 (0.12 RSI)	-	-

¹ Value selected from table 1, p. 26.1 of 2009 ASHRAE Handbook – Fundamentals depending on surface orientation

Detail 5.1.86

Exterior Insulated 3 5/8" x 1 5/8" Steel Stud (16" O.C.) Wall Assembly with Armadillo FRR Vertical Z-Girts Supporting Cladding – Clear Wall

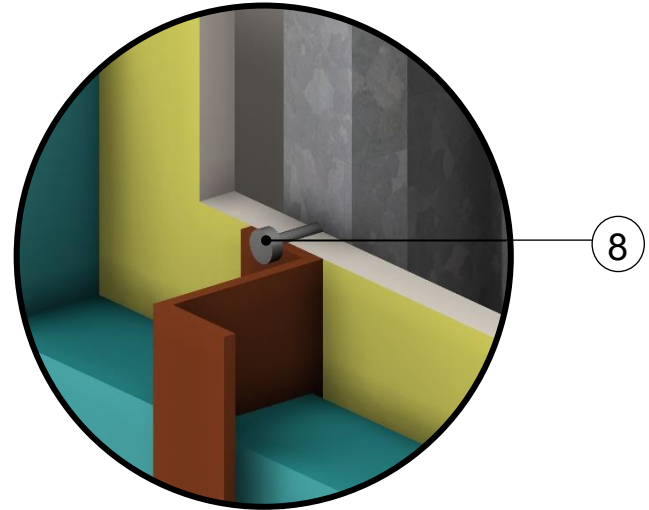
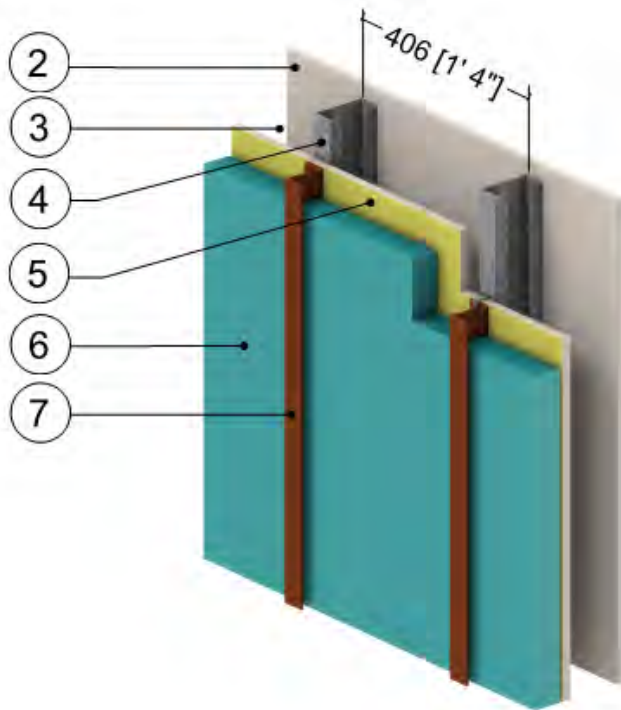

FRR Girt Detail

ID	Component	Thickness Inches (mm)	Conductivity Btu·in / ft ² ·hr·°F (W/m K)	Nominal Resistance hr·ft ² ·°F/Btu (m ² K/W)	Density lb/ft ³ (kg/m ³)	Specific Heat Btu/lb·°F (J/kg K)
1	Interior Film ¹	-	-	R-0.7 (0.12 RSI)	-	-
2	Gypsum Board	1/2" (13)	1.1 (0.16)	R-0.5 (0.08 RSI)	50 (800)	0.26 (1090)
3	Air Cavity	3 5/8" (92)	-	R-0.9 (0.16 RSI)	0.075 (1.2)	0.24 (1000)
4	3 5/8" x 1 5/8" Steel Studs	18 Gauge	430 (62)	-	489 (7830)	0.12 (500)
5	Exterior Sheathing	5/8" (16)	1.1 (0.16)	R-0.6 (0.10 RSI)	50 (800)	0.26 (1090)
6	Exterior Insulation	Varies	-	R-5.0 to R-35.0 (0.88 RSI to 6.16 RSI)	4 (64)	0.20 (850)
7	Armadillo FRR Girt	-	1.4 (0.2)	-	85 (5.3)	-
8	#12 Steel Fasteners (16" o.c.)	7/32" (5.5) ∅	347 (50)	-	489 (7830)	0.12 (500)
9	Generic Cladding with 1/2" (13mm) vented air space is incorporated into exterior heat transfer coefficient					
10	Exterior Film ¹	-	-	R-0.7 (0.12 RSI)	-	-

¹ Value selected from table 1, p. 26.1 of 2009 ASHRAE Handbook – Fundamentals depending on surface orientation

Detail 5.1.87

Exterior and Interior Insulated 3 5/8" x 1 5/8" Steel Stud (16" O.C.) Wall Assembly with Armadillo FRR Vertical Z-Girts Supporting Cladding and R-13 Batt Insulation in Stud Cavity – Clear Wall

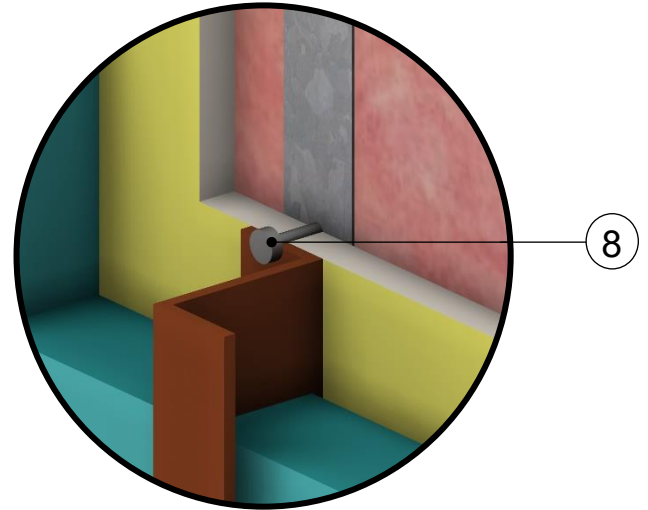
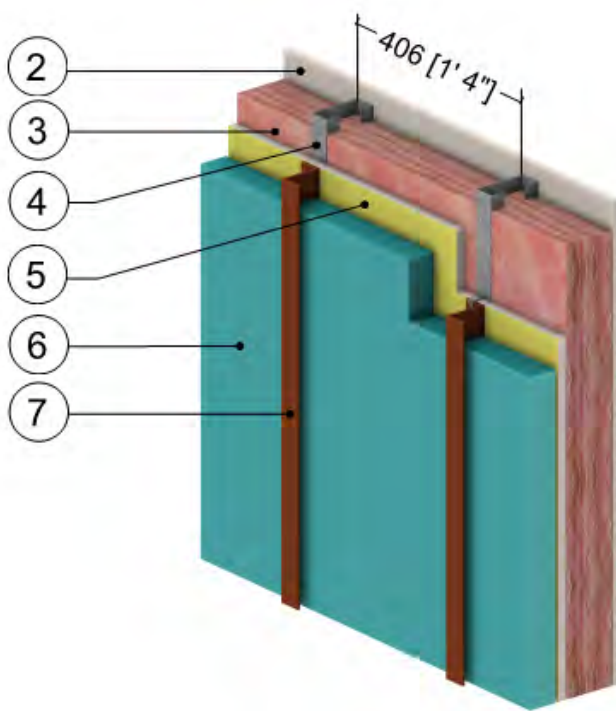

FRR Girt Detail

ID	Component	Thickness Inches (mm)	Conductivity Btu-in / ft ² -hr-°F (W/m K)	Nominal Resistance hr-ft ² -°F/Btu (m ² K/W)	Density lb/ft ³ (kg/m ³)	Specific Heat Btu/lb-°F (J/kg K)
1	Interior Film ¹	-	-	R-0.7 (0.12 RSI)	-	-
2	Gypsum Board	1/2" (13)	1.1 (0.16)	R-0.5 (0.08 RSI)	50 (800)	0.26 (1090)
3	Fiberglass Batt Insulation	3 5/8" (92)	-	R-13.0 (2.29 RSI)	4 (64)	0.20 (850)
4	3 5/8" x 1 5/8" Steel Studs	18 Gauge	430 (62)	-	489 (7830)	0.12 (500)
5	Exterior Sheathing	5/8" (16)	1.1 (0.16)	R-0.6 (0.10 RSI)	50 (800)	0.26 (1090)
6	Exterior Insulation	Varies	-	R-5.0 to R-35.0 (0.88 RSI to 6.16 RSI)	4 (64)	0.20 (850)
7	Armadillo FRR Girt	-	1.4 (0.2)	-	85 (5.3)	-
8	#12 Steel Fasteners (16" o.c.)	7/32" (5.5) ∅	347 (50)	-	489 (7830)	0.12 (500)
9	Generic Cladding with 1/2" (13mm) vented air space is incorporated into exterior heat transfer coefficient					
10	Exterior Film ¹	-	-	R-0.7 (0.12 RSI)	-	-

¹ Value selected from table 1, p. 26.1 of 2009 ASHRAE Handbook – Fundamentals depending on surface orientation

Detail 5.1.88

Exterior Insulated 3 5/8" x 1 5/8" Steel Stud (16" o.c.) Wall Assembly with Brick Ties (24" o.c.) Supporting Brick Veneer – Clear Wall

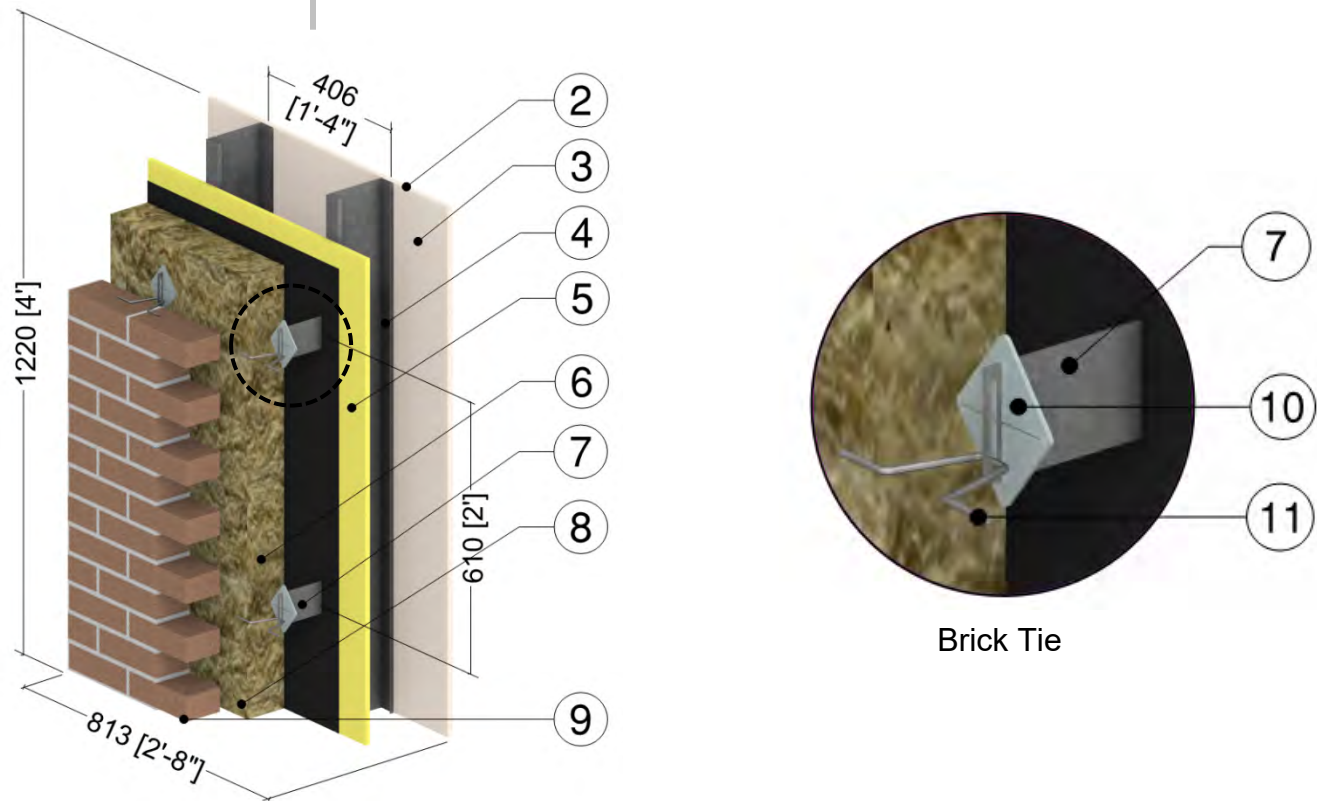

ID	Component	Thickness Inches (mm)	Conductivity Btu·in / ft ² ·hr·°F (W/m K)	Nominal Resistance hr·ft ² ·°F/Btu (m ² K/W)	Density lb/ft ³ (kg/m ³)	Specific Heat Btu/lb·°F (J/kg K)
1	Interior Film ¹	-	-	R-0.7 (0.12 RSI)	-	-
2	Gypsum Board	1/2" (13)	1.1 (0.16)	R-0.5 (0.08 RSI)	50 (800)	0.26 (1090)
3	Air in Stud Cavity	3 5/8" (92)	-	R-0.9 (0.16 RSI)	0.075 (1.2)	0.24 (1000)
4	3 5/8" x 1 5/8" Steel Studs	20 Gauge	430 (62)	-	489 (7830)	0.12 (500)
5	Exterior Sheathing	1/2" (13)	1.1 (0.16)	R-0.5 (0.08 RSI)	50 (800)	0.26 (1090)
6	Exterior Insulation	4" (102)	varies	R-16.8 (2.96 RSI) to R-24.0 (4.23 RSI)	varies	varies
7	Brick Ties	4" (102)	430 (62)	-	445 (7130)	0.09 (390)
8	Vented Air Cavity	1" (25)	-	R-0.4 (0.07 RSI)	0.075 (1.2)	0.24 (1000)
9	Brick Veneer	3 5/8" (92)	5.4 (0.78)	-	120 (1920)	0.19 (720)
10	Insulation Support	1/8" (3)	2.9 (0.42)	-	-	-
11	Brick Tie Wire	-	430 (62)	-	445 (7130)	0.09 (390)
12	Exterior Film ¹	-	-	R-0.2 (0.03 RSI)	-	-

¹ Value selected from table 1, p. 26.1 of 2009 ASHRAE Handbook – Fundamentals depending on surface orientation

Detail 5.1.89

Exterior Insulated 3 5/8" x 1 5/8" Steel Stud (16" o.c.) Wall Assembly with FERO Slotted Rap Ties (24" o.c.) Supporting Brick Veneer – Clear Wall

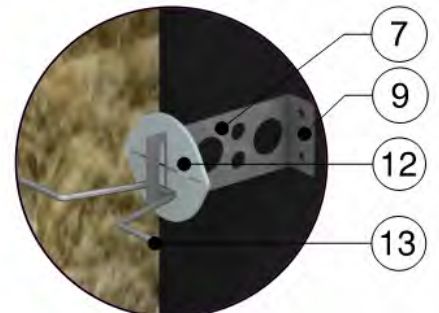
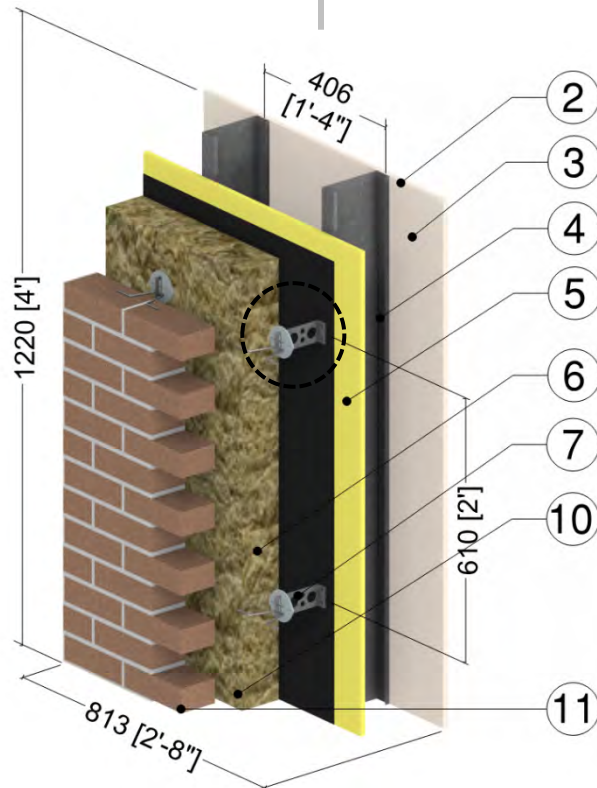

Slotted Rap-Tie

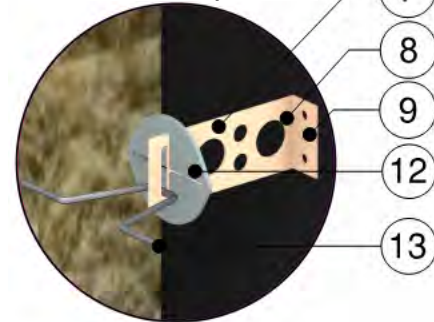

Slotted Rap-Tie with Aerogel Coating

ID	Component	Thickness Inches (mm)	Conductivity Btu-in / ft ² -hr-°F (W/m K)	Nominal Resistance hr-ft ² -°F/Btu (m ² K/W)	Density lb/ft ³ (kg/m ³)	Specific Heat Btu/lb-°F (J/kg K)
1	Interior Film ¹	-	-	R-0.7 (0.12 RSI)	-	-
2	Gypsum Board	1/2" (13)	1.1 (0.16)	R-0.5 (0.08 RSI)	50 (800)	0.26 (1090)
3	Air in Stud Cavity	3 5/8" (92)	-	R-0.9 (0.16 RSI)	0.075 (1.2)	0.24 (1000)
4	3 5/8" x 1 5/8" Steel Studs	20 Gauge	430 (62)	-	489 (7830)	0.12 (500)
5	Exterior Sheathing	1/2" (13)	1.1 (0.16)	R-0.5 (0.08 RSI)	50 (800)	0.26 (1090)
6	Exterior Insulation	4" (102)	varies	R-16.8 (2.96 RSI) to R-24.0 (4.23 RSI)	varies	varies
7	FERO Slotted Rap-Ties	4" (102)	430 (62)	-	445 (7130)	0.09 (390)
8	Aerogel Coating	1/8" (3)	0.24 (0.035)	-	-	-
9	Tie Fastener	5/16" (8) Ø	118 (17)	-	489 (7830)	0.12 (500)
10	Vented Air Cavity	1" (25)	-	R-0.4 (0.07 RSI)	0.075 (1.2)	0.24 (1000)
11	Brick Veneer	3 5/8" (92)	5.4 (0.78)	-	120 (1920)	0.19 (720)
12	Insulation Support	1/8" (3)	2.9 (0.42)	-	-	-
13	Brick Tie Wire	-	430 (62)	-	445 (7130)	0.09 (390)
14	Exterior Film ¹	-	-	R-0.2 (0.03 RSI)	-	-

¹ Value selected from table 1, p. 26.1 of 2009 ASHRAE Handbook – Fundamentals depending on surface orientation

Detail 5.1.90

Exterior Insulated 6" x 1 5/8" Steel Stud (16" O.C.) Wall Assembly with Fiber Reinforced Plastic Clip Supporting Cladding – Clear Wall

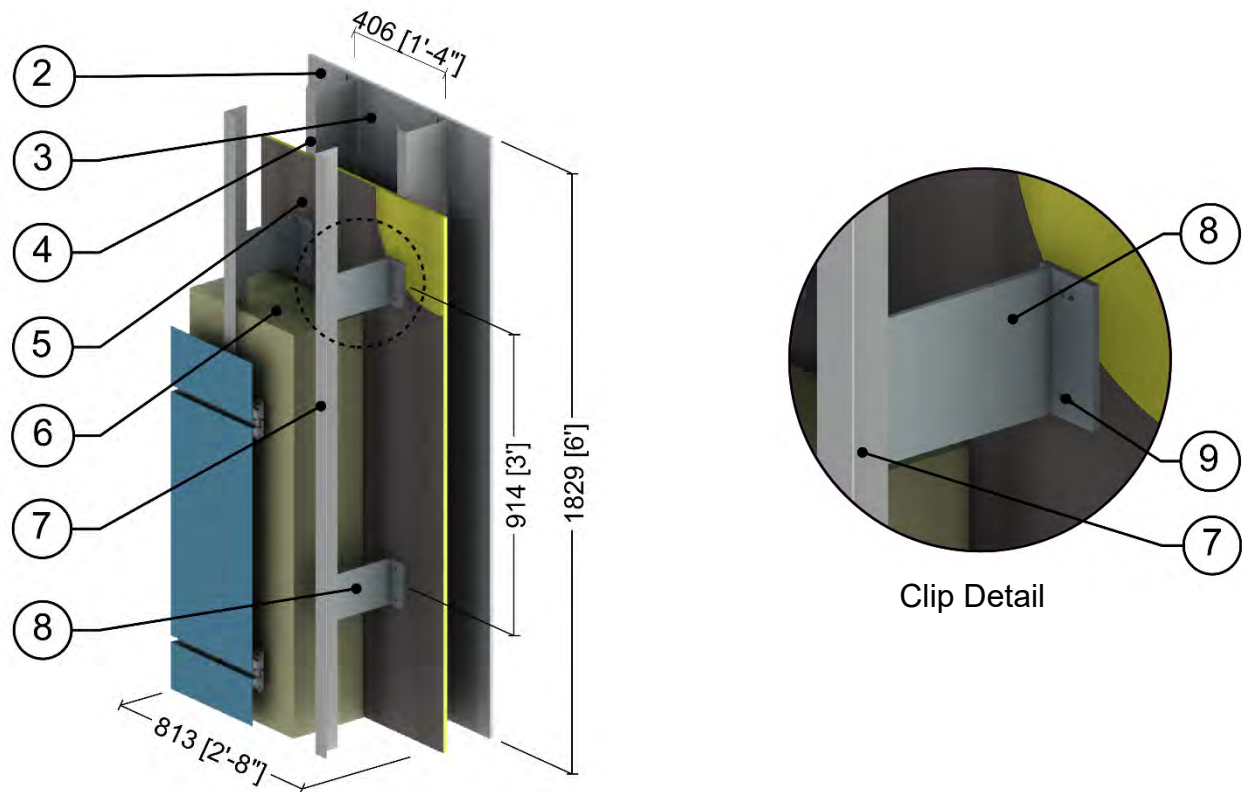

ID	Component	Thickness Inches (mm)	Conductivity Btu-in / ft ² -hr-°F (W/m K)	Nominal Resistance hr-ft ² -°F/Btu (m ² K/W)	Density lb/ft ³ (kg/m ³)	Specific Heat Btu/lb-°F (J/kg K)
1	Interior Films ¹	-	-	R-0.7 (0.12 RSI)	-	-
2	Gypsum Board	1/2" (13)	1.1 (0.16)	R-0.5 (0.08 RSI)	50 (800)	0.26 (1090)
3	Air in Stud Cavity	6" (152)	-	R-0.9 (0.16 RSI)	0.075 (1.2)	0.24 (1000)
4	6" x 1 5/8" Steel Studs	18 Gauge	430 (62)	-	489 (7830)	0.12 (500)
5	Exterior Sheathing	1/2" (13)	1.1 (0.16)	R-0.5 (0.08 RSI)	50 (800)	0.26 (1090)
6	Exterior Mineral Wool Insulation	Varies	0.24 (0.034)	R-25.2 to R-42.0 (4.44 to 7.40 RSI)	4 (64)	0.20 (850)
7	Vertical Aluminum L-girt	0.10" (2.5)	1339 (193)	-	169 (2700)	0.22 (900)
8	Fiber Reinforced Plastic Clip	0.22" (5.5)	4.9 (0.7)	-	-	-
9	#14 Stainless Steel Fasteners	1/4" (6) Ø	118 (17)	-	500 (8000)	0.12 (500)
10	Cladding with 1/2" vented airspace incorporated into exterior heat transfer coefficient					
11	Exterior Film ¹	-	-	R-0.7 (0.12 RSI)	-	-

¹ Value selected from table 1, p. 26.1 of 2009 ASHRAE Handbook – Fundamentals depending on surface orientation

Detail 5.1.91

Exterior and Interior Insulated 6" x 1 5/8" Steel Stud (16" O.C.) Wall Assembly with Fiber Reinforced Plastic Clip Supporting Metal Cladding and R-19 Batt in Stud Cavity – Clear Wall

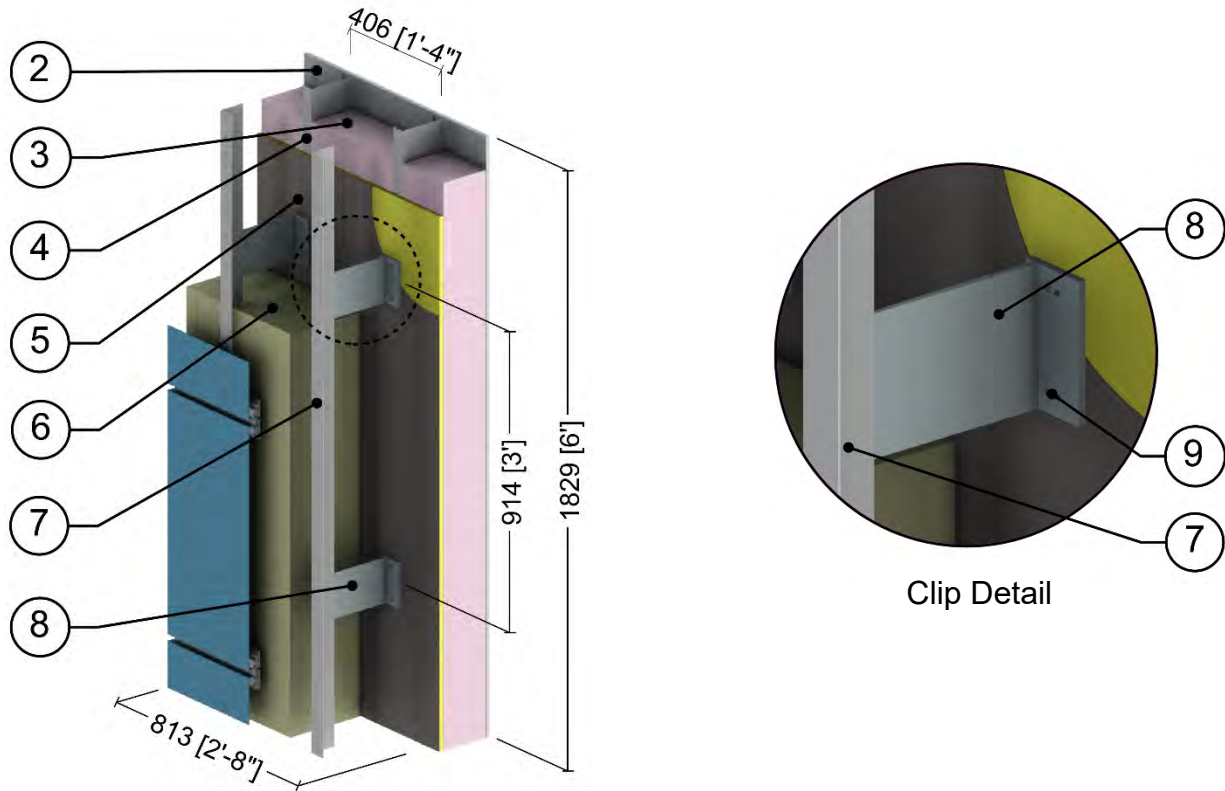

ID	Component	Thickness Inches (mm)	Conductivity Btu-in / ft ² -hr-°F (W/m K)	Nominal Resistance hr-ft ² -°F/Btu (m ² K/W)	Density lb/ft ³ (kg/m ³)	Specific Heat Btu/lb-°F (J/kg K)
1	Interior Films ¹	-	-	R-0.7 (0.12 RSI)	-	-
2	Gypsum Board	1/2" (13)	1.1 (0.16)	R-0.5 (0.08 RSI)	50 (800)	0.26 (1090)
3	Fiberglass Batt Insulation	6" (152)	0.32 (0.046)	R-19 (3.3 RSI)	0.9 (14)	0.17 (710)
4	6" x 1 5/8" Steel Studs	18 Gauge	430 (62)	-	489 (7830)	0.12 (500)
5	Exterior Sheathing	1/2" (13)	1.1 (0.16)	R-0.5 (0.08 RSI)	50 (800)	0.26 (1090)
6	Exterior Mineral Wool Insulation	Varies	0.24 (0.034)	R-25.2 to R-42.0 (4.44 to 7.40 RSI)	4 (64)	0.20 (850)
7	Vertical Aluminum L-girt	0.10" (2.5)	1339 (193)	-	169 (2700)	0.22 (900)
8	Fiber Reinforced Plastic Clip	0.22" (5.5)	4.9 (0.7)	-	-	-
9	#14 Stainless Steel Fasteners	1/4" (6) Ø	118 (17)	-	500 (8000)	0.12 (500)
10	Cladding with 1/2" vented airspace incorporated into exterior heat transfer coefficient					
11	Exterior Film ¹	-	-	R-0.7 (0.12 RSI)	-	-

¹ Value selected from table 1, p. 26.1 of 2009 ASHRAE Handbook – Fundamentals depending on surface orientation

Detail 5.1.92 Exterior Insulated 6" x 1 5/8" Steel Stud (16" O.C.) Wall Assembly with Double Aluminum Bracket Supporting Metal Cladding

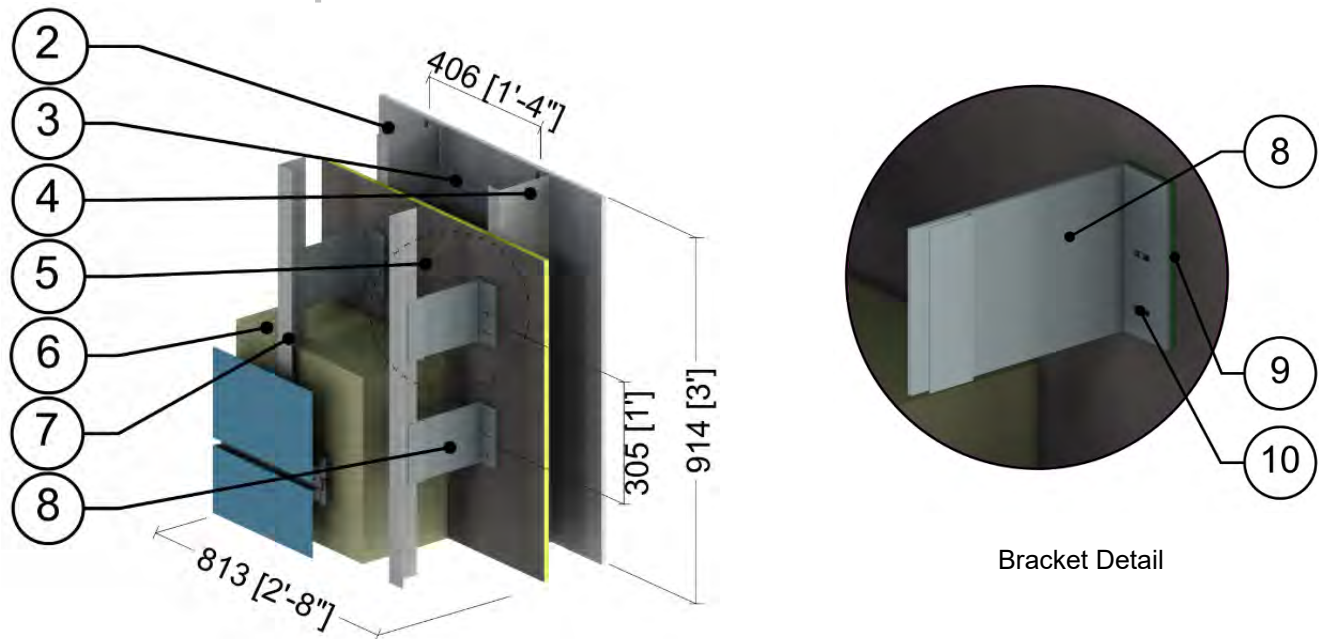

ID	Component	Thickness Inches (mm)	Conductivity Btu·in / ft ² ·hr·°F (W/m K)	Nominal Resistance hr·ft ² ·°F/Btu (m ² K/W)	Density lb/ft ³ (kg/m ³)	Specific Heat Btu/lb·°F (J/kg K)
1	Interior Films ¹	-	-	R-0.7 (0.12 RSI)	-	-
2	Gypsum Board	1/2" (13)	1.1 (0.16)	R-0.5 (0.08 RSI)	50 (800)	0.26 (1090)
3	Air in Stud Cavity	6" (152)	-	R-0.9 (0.16 RSI)	0.075 (1.2)	0.24 (1000)
4	6" x 1 5/8" Steel Studs	18 Gauge	430 (62)	-	489 (7830)	0.12 (500)
5	Exterior Sheathing	1/2" (13)	1.1 (0.16)	R-0.5 (0.08 RSI)	50 (800)	0.26 (1090)
6	Exterior Mineral Wool Insulation	Varies	0.24 (0.034)	R-25.2 to R-42.0 (4.44 to 7.40 RSI)	4 (64)	0.20 (850)
7	Vertical Aluminum L-girt	0.10" (2.5)	1339 (193)	-	169 (2700)	0.22 (900)
8	Aluminum Bracket	Varies	1339 (193)	-	169 (2700)	0.22 (900)
9	Isolator Pad	0.2" (5)	0.82 (0.117)	-	87 (1400)	0.20 (840)
10	#14 Stainless Steel Fasteners	1/4" (6) Ø	118 (17)	-	500 (8000)	0.12 (500)
11	Cladding with 1/2" vented airspace incorporated into exterior heat transfer coefficient					
12	Exterior Film ¹	-	-	R-0.7 (0.12 RSI)	-	-

¹ Value selected from table 1, p. 26.1 of 2009 ASHRAE Handbook – Fundamentals depending on surface orientation

Detail 5.1.93

Exterior and Interior Insulated 6" x 1 5/8" Steel Stud (16" O.C.) Wall Assembly with Double Aluminum Bracket Supporting Metal Cladding and R-19 Batt Insulation in Stud Cavity

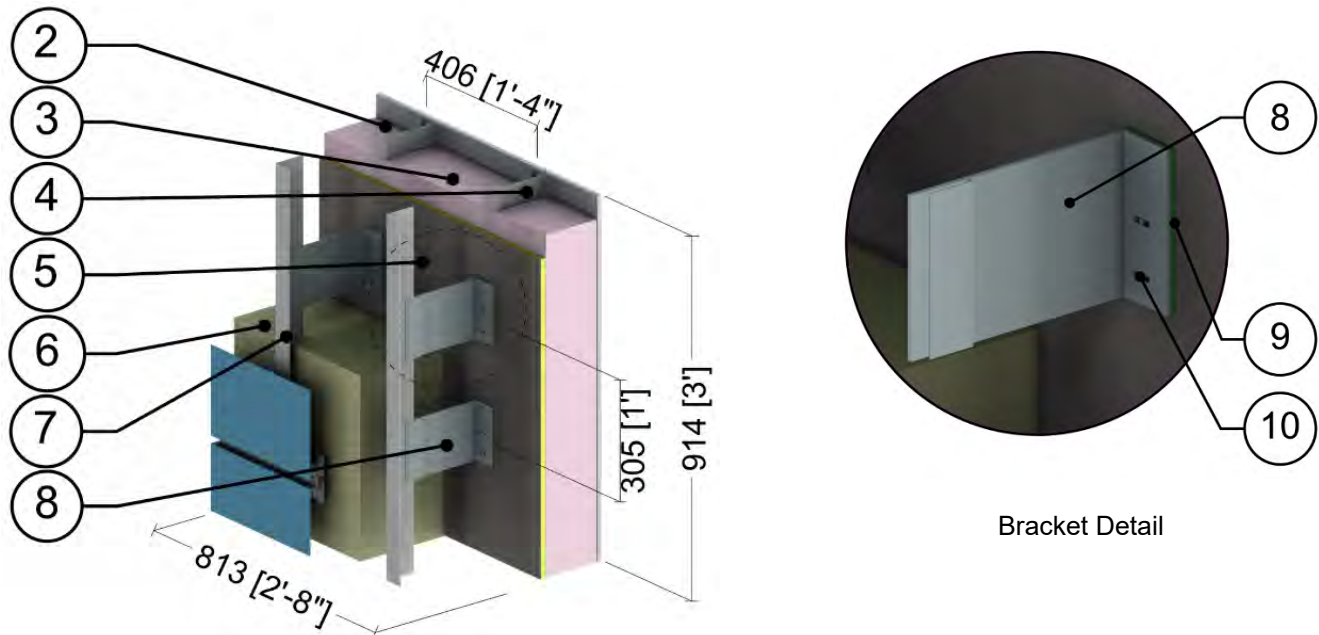

ID	Component	Thickness Inches (mm)	Conductivity Btu·in / ft ² ·hr·°F (W/m K)	Nominal Resistance hr·ft ² ·°F/Btu (m ² K/W)	Density lb/ft ³ (kg/m ³)	Specific Heat Btu/lb·°F (J/kg K)
1	Interior Films ¹	-	-	R-0.7 (0.12 RSI)	-	-
2	Gypsum Board	1/2" (13)	1.1 (0.16)	R-0.5 (0.08 RSI)	50 (800)	0.26 (1090)
3	Fiberglass Batt Insulation	6" (152)	0.32 (0.046)	R-19 (3.3 RSI)	0.9 (14)	0.17 (710)
4	6" x 1 5/8" Steel Studs	18 Gauge	430 (62)	-	489 (7830)	0.12 (500)
5	Exterior Sheathing	1/2" (13)	1.1 (0.16)	R-0.5 (0.08 RSI)	50 (800)	0.26 (1090)
6	Exterior Mineral Wool Insulation	Varies	0.24 (0.034)	R-25.2 to R-42.0 (4.44 to 7.40 RSI)	4 (64)	0.20 (850)
7	Vertical Aluminum L-girt	0.10" (2.5)	1339 (193)	-	169 (2700)	0.22 (900)
8	Aluminum Bracket	Varies	1340 (193)	-	169 (2700)	0.22 (900)
9	Isolator Pad	0.2" (5)	0.82 (0.117)	-	87 (1400)	0.20 (840)
10	#14 Stainless Steel Fasteners	1/4" (6) Ø	118 (17)	-	500 (8000)	0.12 (500)
11	Cladding with 1/2" vented airspace incorporated into exterior heat transfer coefficient					
12	Exterior Film ¹	-	-	R-0.7 (0.12 RSI)	-	-

¹ Value selected from table 1, p. 26.1 of 2009 ASHRAE Handbook – Fundamentals depending on surface orientation

Detail 5.1.94 Exterior Insulated 6" x 1 5/8" Steel Stud (16" O.C.) Wall Assembly with Technoform Clip and Steel Fasteners - Clear Wall

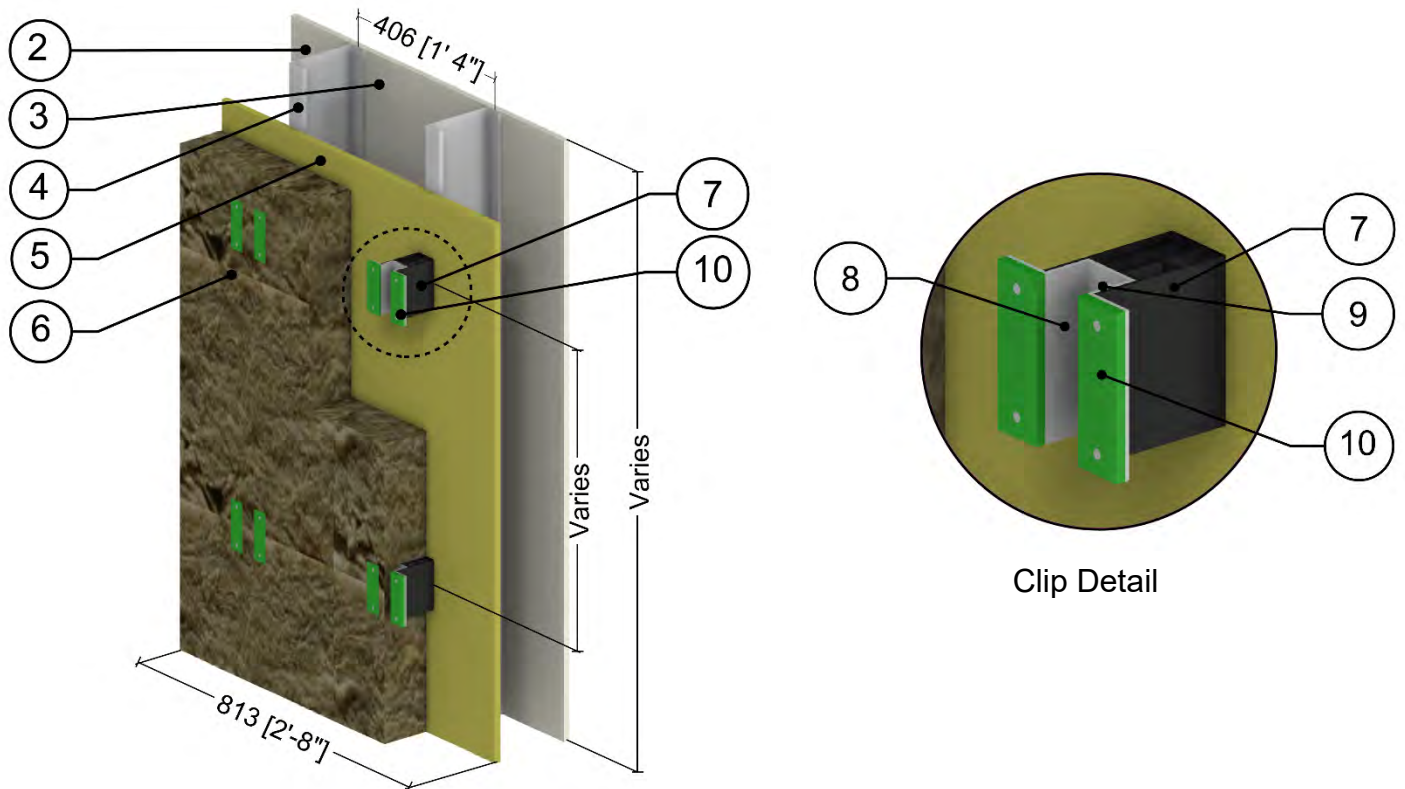

ID	Component	Thickness Inches (mm)	Conductivity Btu-in / ft ² ·hr·°F (W/m K)	Nominal Resistance hr·ft ² ·°F/Btu (m ² K/W)	Density lb/ft ³ (kg/m ³)	Specific Heat Btu/lb·°F (J/kg K)
1	Interior Films ¹	-	-	R-0.7 (0.12 RSI)	-	-
2	Gypsum Board	1/2" (13)	1.1 (0.16)	R-0.5 (0.09 RSI)	50 (800)	0.26 (1090)
3	Air in Stud Cavity	6" (152)	-	R-0.9 (0.16 RSI)	0.075 (1.2)	0.24 (1000)
4	6" x 1 5/8" Steel Studs	18 Gauge	430 (62)	-	489 (7830)	0.12 (500)
5	Exterior Sheathing	5/8" (16)	1.1 (0.16)	R-0.5 (0.09 RSI)	50 (800)	0.26 (1090)
6	Exterior Mineral Wool Insulation	Varies	-	R-8.4 to R-33.6 (1.48 to 5.92 RSI)	4 (64)	0.20 (850)
7	Polyamide Thermal Break	Varies	1.7 (0.25)	-	-	-
8	Aluminum C-Channel	-	1390 (200)	-	168 (2700)	0.22 (900)
9	Fasteners	1/4" (6) Ø	347 (50)	-	489 (7830)	0.12 (500)
10	Spacer Shims	1/4" (6)	1.7 (0.25)	-	-	-
11	Cladding with 1/2" vented airspace incorporated into exterior heat transfer coefficient					
12	Exterior Film ¹	-	-	R-0.7 (0.12 RSI)	-	-

¹ Value selected from table 1, p. 26.1 of 2009 ASHRAE Handbook – Fundamentals depending on surface orientation

Detail 5.1.95

Exterior Insulated 6" x 1 5/8" Steel Stud (16" O.C.) Wall Assembly with Technoform Clip and Stainless Steel Fasteners - Clear Wall

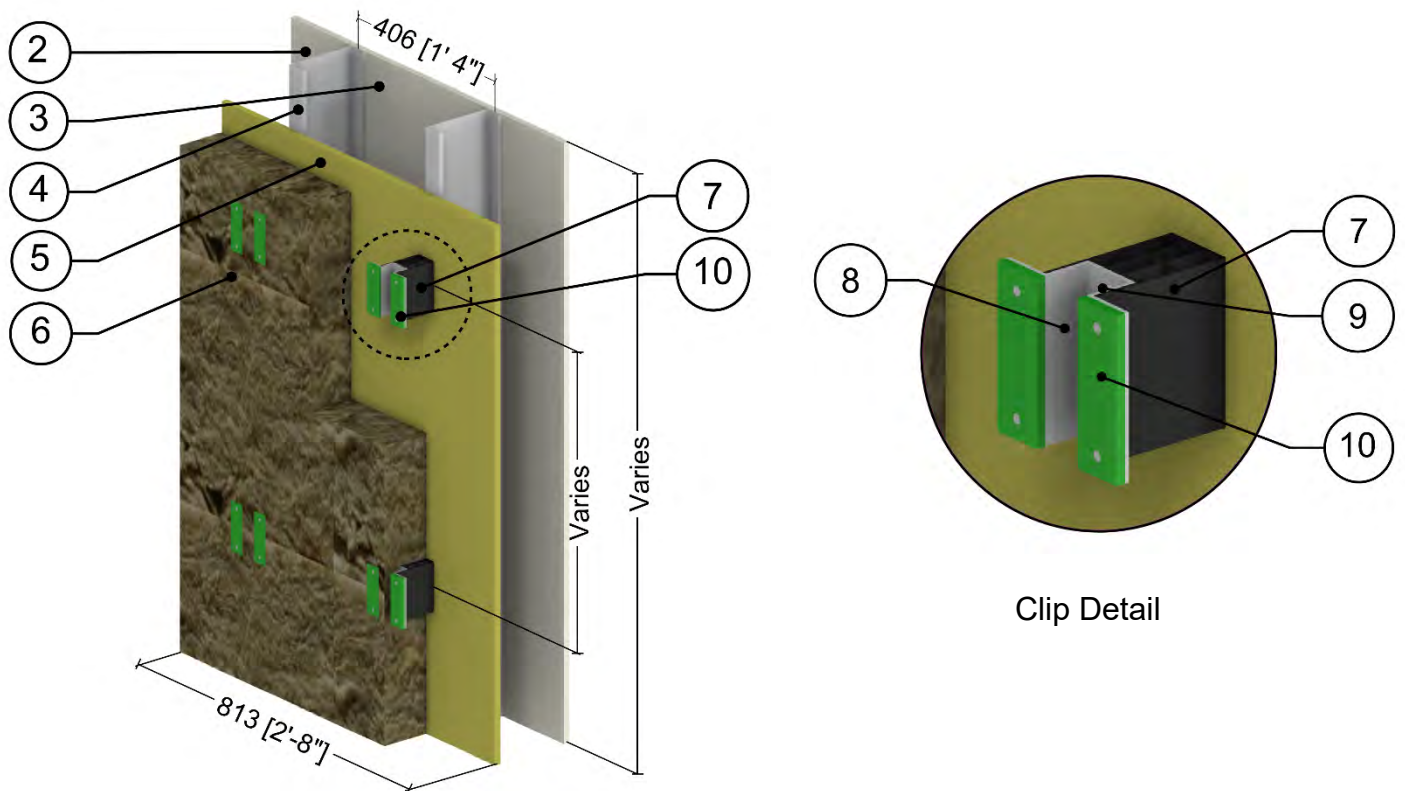

ID	Component	Thickness Inches (mm)	Conductivity Btu-in / ft ² -hr-°F (W/m K)	Nominal Resistance hr-ft ² -°F/Btu (m ² K/W)	Density lb/ft ³ (kg/m ³)	Specific Heat Btu/lb-°F (J/kg K)
1	Interior Films ¹	-	-	R-0.7 (0.12 RSI)	-	-
2	Gypsum Board	1/2" (13)	1.1 (0.16)	R-0.5 (0.09 RSI)	50 (800)	0.26 (1090)
3	Air in Stud Cavity	6" (152)	-	R-0.9 (0.16 RSI)	0.075 (1.2)	0.24 (1000)
4	6" x 1 5/8" Steel Studs	18 Gauge	430 (62)	-	489 (7830)	0.12 (500)
5	Exterior Sheathing	5/8" (16)	1.1 (0.16)	R-0.5 (0.09 RSI)	50 (800)	0.26 (1090)
6	Exterior Mineral Wool Insulation	Varies	-	R-8.4 to R-33.6 (1.48 to 5.92 RSI)	4 (64)	0.20 (850)
7	Polyamide Thermal Break	Varies	1.7 (0.25)	-	-	-
8	Aluminum C-Channel	-	1390 (200)	-	168 (2700)	0.22 (900)
9	Fasteners	1/4" (6) Ø	111 (16)	-	500 (8000)	0.12 (500)
10	Spacer Shims	1/4" (6)	1.7 (0.25)	-	-	-
11	Cladding with 1/2" vented airspace incorporated into exterior heat transfer coefficient					
12	Exterior Film ¹	-	-	R-0.7 (0.12 RSI)	-	-

¹ Value selected from table 1, p. 26.1 of 2009 ASHRAE Handbook – Fundamentals depending on surface orientation

Detail 5.1.96

Exterior and Interior Insulated 6" x 1 5/8" Steel Stud (16" o.c.) Wall Assembly with Galvanized Horizontal Intermittent Clips (24" o.c.) Supporting Metal Cladding and Owens Corning R-20 Batt Insulation in Stud Cavity – Clear Wall

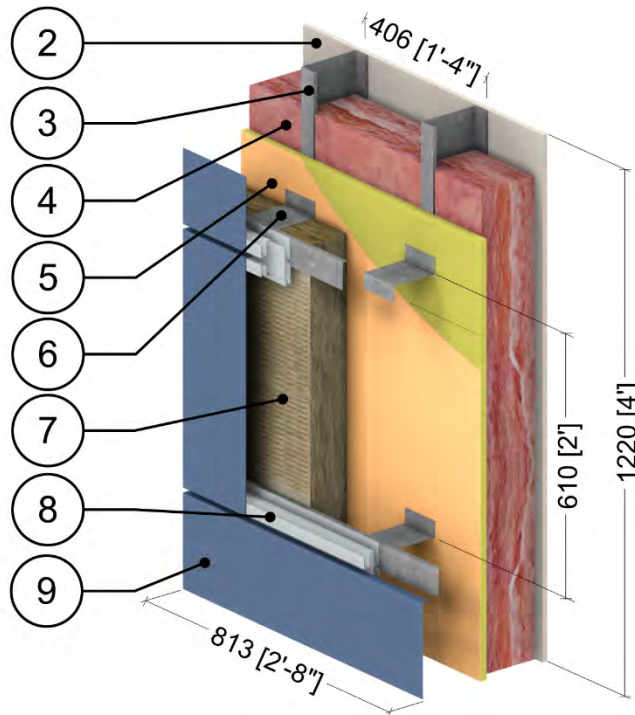

ID	Component	Thickness Inches (mm)	Conductivity Btu-in / ft ² ·hr·°F (W/m K)	Nominal Resistance hr·ft ² ·°F/Btu (m ² K/W)	Density lb/ft ³ (kg/m ³)	Specific Heat Btu/lb·°F (J/kg K)
1	Interior Film ¹	-	-	R-0.7 (0.12 RSI)	-	-
2	Gypsum Board	1/2" (13)	1.1 (0.16)	R-0.5 (0.08 RSI)	50 (800)	0.26 (1090)
3	6" x 1 5/8" Steel Studs	18 Gauge	430 (62)	-	489 (7830)	0.12 (500)
4	Ecotouch Pink Fiberglass Batt	6" (152)	-	R-20 (3.52 RSI)	varies	0.17 (710)
5	Exterior Sheathing	5/8" (16)	1.1 (0.16)	R-0.6 (0.10 RSI)	50 (800)	0.26 (1090)
6	Horizontal Clips w/ 1 1/2" horizontal rail	18 Gauge	430 (62)	-	489 (7830)	0.12 (500)
7	Thermafiber RainBarrier 45 Mineral Wool Semi Rigid Insulation	Varies	0.24 (0.034)	R-6.3 to R-21.0 (1.11 to 3.70 RSI)	4.5 (72)	0.20 (850)
8	Panel Clip	14 Gauge	430 (62)	-	489 (7830)	0.12 (500)
9	Metal Cladding with 1/2" vented airspace incorporated into exterior heat transfer coefficient					
10	Exterior Film ¹	-	-	R-0.7 (0.12 RSI)	-	-

¹ Value selected from table 1, p. 26.1 of 2009 ASHRAE Handbook – Fundamentals depending on surface orientation

Detail 5.1.97

Exterior and Interior Insulated 6" x 1 5/8" Steel Stud (16" o.c.) Wall Assembly with Galvanized Horizontal Intermittent Clips (24" o.c.) Supporting Metal Cladding and Owens Corning R-22.5 Batt Insulation in Stud Cavity – Clear Wall

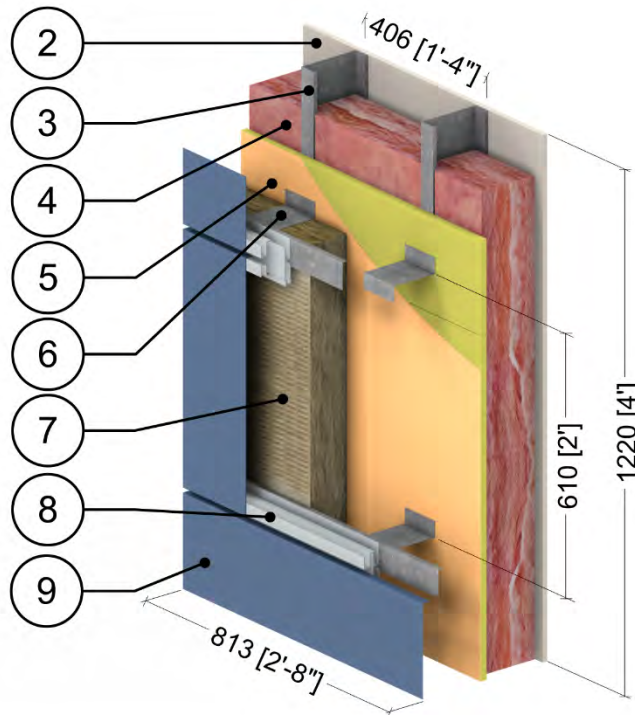

ID	Component	Thickness Inches (mm)	Conductivity Btu-in / ft ² ·hr·°F (W/m K)	Nominal Resistance hr·ft ² ·°F/Btu (m ² K/W)	Density lb/ft ³ (kg/m ³)	Specific Heat Btu/lb·°F (J/kg K)
1	Interior Film ¹	-	-	R-0.7 (0.12 RSI)	-	-
2	Gypsum Board	1/2" (13)	1.1 (0.16)	R-0.5 (0.08 RSI)	50 (800)	0.26 (1090)
3	6" x 1 5/8" Steel Studs	18 Gauge	430 (62)	-	489 (7830)	0.12 (500)
4	Ecotouch Pink Fiberglass Batt	6" (152)	0.26 (0.038)	R-22.5 (4.0 RSI)	0.99 (15.9)	0.17 (710)
5	Exterior Sheathing	5/8" (16)	1.1 (0.16)	R-0.6 (0.10 RSI)	50 (800)	0.26 (1090)
6	Horizontal Clips w/ 1 1/2" horizontal rail	18 Gauge	430 (62)	-	489 (7830)	0.12 (500)
7	Thermafiber RainBarrier 45 Mineral Wool Semi Rigid Insulation	Varies	0.24 (0.034)	R-6.3 to R-21.0 (1.11 to 3.70 RSI)	4.5 (72)	0.20 (850)
8	Panel Clip	14 Gauge	430 (62)	-	489 (7830)	0.12 (500)
9	Metal Cladding with 1/2" vented airspace incorporated into exterior heat transfer coefficient					
10	Exterior Film ¹	-	-	R-0.7 (0.12 RSI)	-	-

¹ Value selected from table 1, p. 26.1 of 2009 ASHRAE Handbook – Fundamentals depending on surface orientation

Detail 5.1.98

Exterior and Interior Insulated 6" x 1 5/8" Steel Stud (16" o.c.) Wall Assembly with Galvanized Horizontal Intermittent Clips (24" o.c.) Supporting Metal Cladding and Owens Corning R-24 Batt Insulation in Stud Cavity – Clear Wall

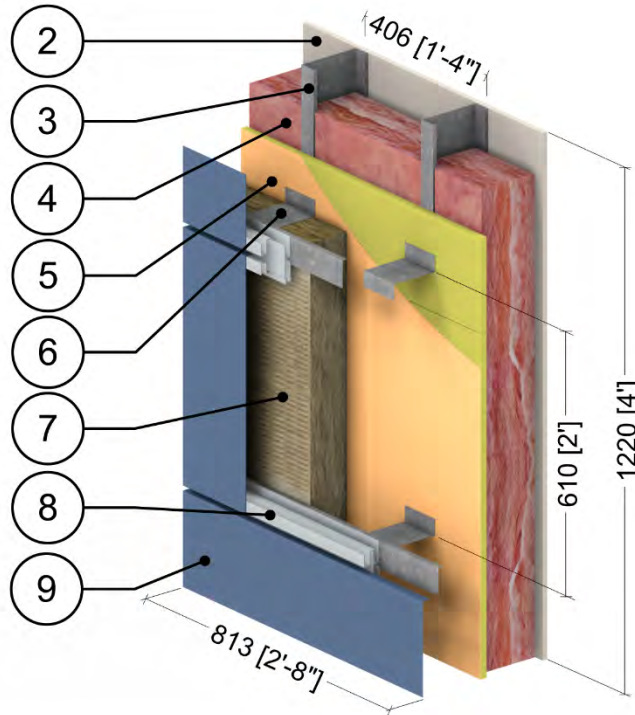

ID	Component	Thickness Inches (mm)	Conductivity Btu-in / ft ² ·hr·°F (W/m K)	Nominal Resistance hr·ft ² ·°F/Btu (m ² K/W)	Density lb/ft ³ (kg/m ³)	Specific Heat Btu/lb·°F (J/kg K)
1	Interior Film ¹	-	-	R-0.7 (0.12 RSI)	-	-
2	Gypsum Board	1/2" (13)	1.1 (0.16)	R-0.5 (0.08 RSI)	50 (800)	0.26 (1090)
3	6" x 1 5/8" Steel Studs	18 Gauge	430 (62)	-	489 (7830)	0.12 (500)
4	Ecotouch Pink Fiberglass Batt	6" (152)	0.25 (0.036)	R-24 (4.2 RSI)	1.42 (22.7)	0.17 (710)
5	Exterior Sheathing	5/8" (16)	1.1 (0.16)	R-0.6 (0.10 RSI)	50 (800)	0.26 (1090)
6	Horizontal Clips w/ 1 1/2" horizontal rail	18 Gauge	430 (62)	-	489 (7830)	0.12 (500)
7	Thermafiber RainBarrier 45 Mineral Wool Semi Rigid Insulation	Varies	0.24 (0.034)	R-6.3 to R-21.0 (1.11 to 3.70 RSI)	4.5 (72)	0.20 (850)
8	Panel Clip	14 Gauge	430 (62)	-	489 (7830)	0.12 (500)
9	Metal Cladding with 1/2" vented airspace incorporated into exterior heat transfer coefficient					
10	Exterior Film ¹	-	-	R-0.7 (0.12 RSI)	-	-

¹ Value selected from table 1, p. 26.1 of 2009 ASHRAE Handbook – Fundamentals depending on surface orientation

Detail 5.1.99

Exterior Insulated 6" x 1 5/8" Steel Stud (16" o.c.) Wall Assembly with EJOT Crossfix Console and Horizontal Rail System Supporting Metal Cladding - Clear Wall

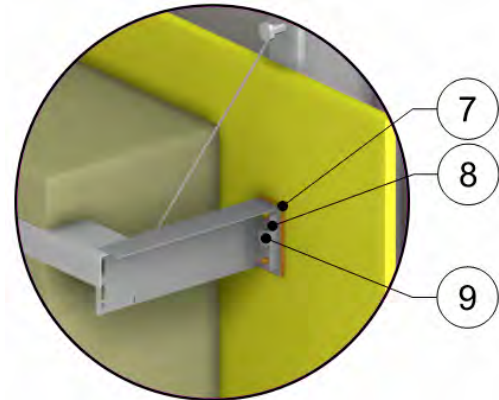
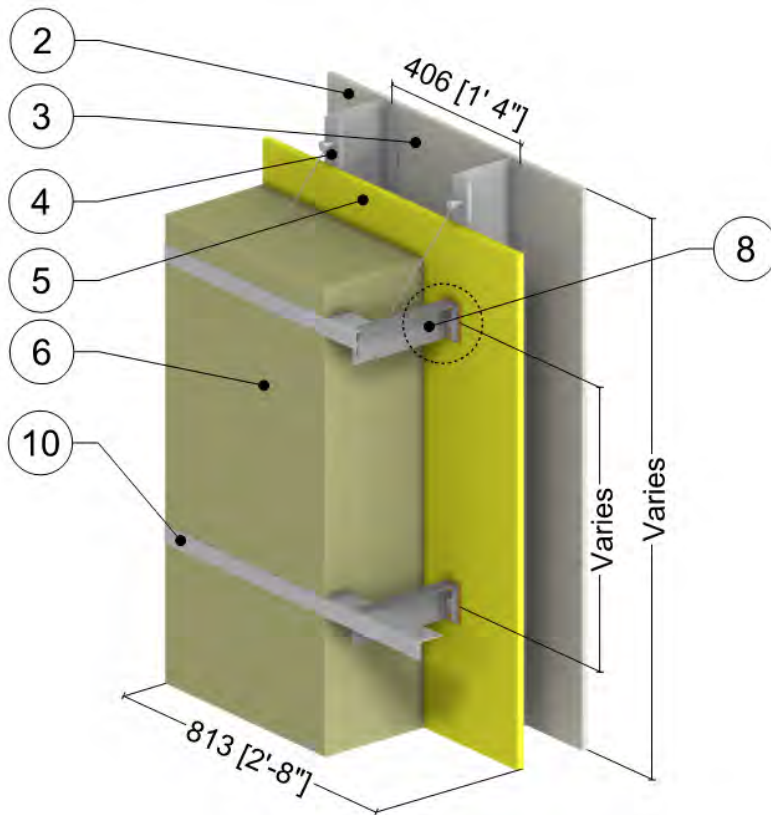

Console Detail

Exterior Insulation Thickness for Console Sizes

Crossfix Console Size	Exterior Insulation Thickness in (mm)
40	2 (51)
80	3.5 (89)
120	5 (127)
200	8.5 (216)
240	10 (254)
320	13 (330)
400	16 (406)

ID	Component	Thickness Inches (mm)	Conductivity Btu-in / ft ² -hr-°F (W/m K)	Nominal Resistance hr-ft ² -°F/Btu (m ² K/W)	Density lb/ft ³ (kg/m ³)	Specific Heat Btu/lb-°F (J/kg K)
1	Interior Film ¹	-	-	R-0.7 (0.12 RSI)	-	-
2	Gypsum Board	1/2" (13)	1.1 (0.16)	R-0.5 (0.09 RSI)	50 (800)	0.26 (1090)
3	Air in Stud Cavity	6" (152)	-	R-0.9 (0.16 RSI)	0.075 (1.2)	0.24 (1000)
4	6" x 1 5/8" Steel Studs	18 Gauge	430 (62)	-	489 (7830)	0.12 (500)
5	Exterior Sheathing	5/8" (16)	1.1 (0.16)	R-0.6 (0.10 RSI)	50 (800)	0.26 (1090)
6	Exterior Mineral Wool Insulation	Varies	0.24 (0.034)	R-8.4 to R-67.2 (1.48 to 11.84 RSI)	4 (64)	0.20 (850)
7	Thermostop	0.2" (5)	2.2 (0.32)	-	69 (1100)	0.36 (1500)
8	EJOT Console and Components	0.06" (1.5)	112 (16)	-	499 (8000)	0.12 (500)
9	Fastener	0.22" (5.5) Ø	112 (16)	-	499 (8000)	0.12 (500)
10	Rail	0.08" (2)	1110 (160)	-	-	-
11	Cladding with 1/2" vented airspace incorporated into exterior heat transfer coefficient					
12	Exterior Film ¹	-	-	R-0.7 (0.12 RSI)	-	-

¹ Value selected from table 1, p. 26.1 of 2009 ASHRAE Handbook – Fundamentals depending on surface orientation

Detail 5.1.100

Exterior and Interior Insulated 6" x 1 5/8" Steel Stud (16" o.c.) Wall Assembly with EJOT Crossfix Console and Horizontal Rail System Supporting Metal Cladding and R-20 Batt Insulation in Stud Cavity - Clear Wall

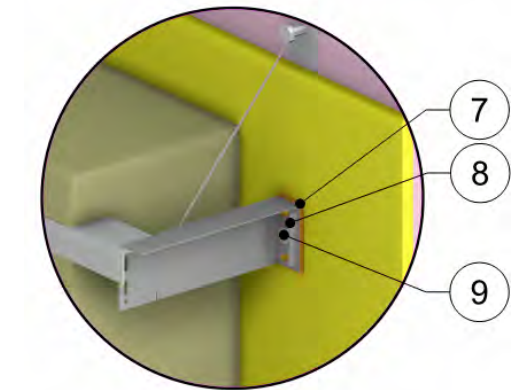
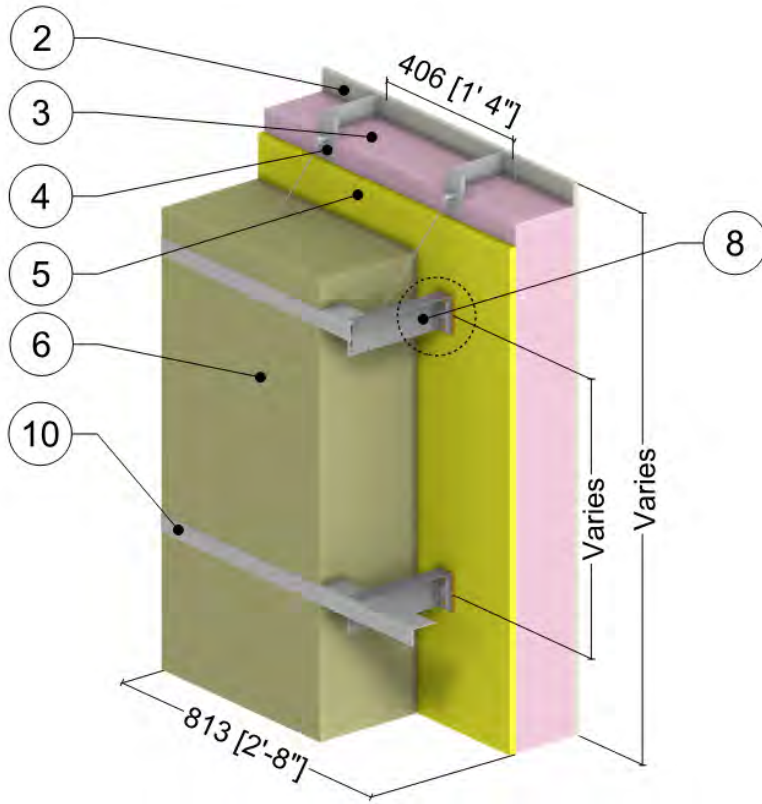

Console Detail

Exterior Insulation Thickness for Console Sizes

Crossfix Console Size	Exterior Insulation Thickness in (mm)
40	2 (51)
80	3.5 (89)
120	5 (127)
200	8.5 (216)
240	10 (254)
320	13 (330)
400	16 (406)

ID	Component	Thickness Inches (mm)	Conductivity Btu·in / ft ² ·hr·°F (W/m K)	Nominal Resistance hr·ft ² ·°F/Btu (m ² K/W)	Density lb/ft ³ (kg/m ³)	Specific Heat Btu/lb·°F (J/kg K)
1	Interior Film ¹	-	-	R-0.7 (0.12 RSI)	-	-
2	Gypsum Board	1/2" (13)	1.1 (0.16)	R-0.5 (0.09 RSI)	50 (800)	0.26 (1090)
3	Fiberglass Batt Insulation	6" (152)	0.30 (0.043)	R-20 (3.5 RSI)	0.55 (8.8)	0.17 (710)
4	6" x 1 5/8" Steel Studs	18 Gauge	430 (62)	-	489 (7830)	0.12 (500)
5	Exterior Sheathing	5/8" (16)	1.1 (0.16)	R-0.6 (0.10 RSI)	50 (800)	0.26 (1090)
6	Exterior Mineral Wool Insulation	Varies	0.24 (0.034)	R-8.4 to R-67.2 (1.48 to 11.84 RSI)	4 (64)	0.20 (850)
7	Thermostop	0.2" (5)	2.2 (0.32)	-	69 (1100)	0.36 (1500)
8	EJOT Console and Components	0.06" (1.5)	112 (16)	-	499 (8000)	0.12 (500)
9	Fastener	0.22" (5.5) Ø	112 (16)	-	499 (8000)	0.12 (500)
10	Rail	0.08" (2)	1110 (160)	-	-	-
11	Cladding with 1/2" vented airspace incorporated into exterior heat transfer coefficient					
12	Exterior Film ¹	-	-	R-0.7 (0.12 RSI)	-	-

¹ Value selected from table 1, p. 26.1 of 2009 ASHRAE Handbook – Fundamentals depending on surface orientation

Detail 5.1.101

Exterior Insulated 6" x 1 5/8" Steel Stud (24" o.c.) Wall Assembly with EJOT Crossfix Console and Horizontal Rail System Supporting Metal Cladding - Clear Wall

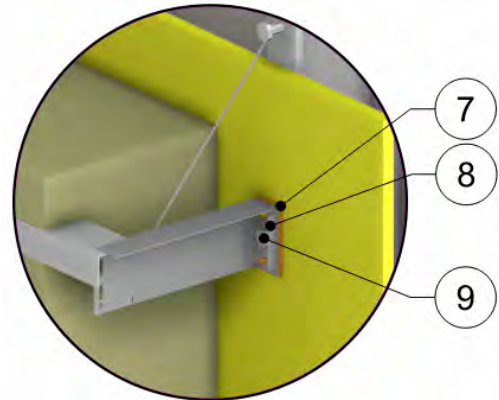
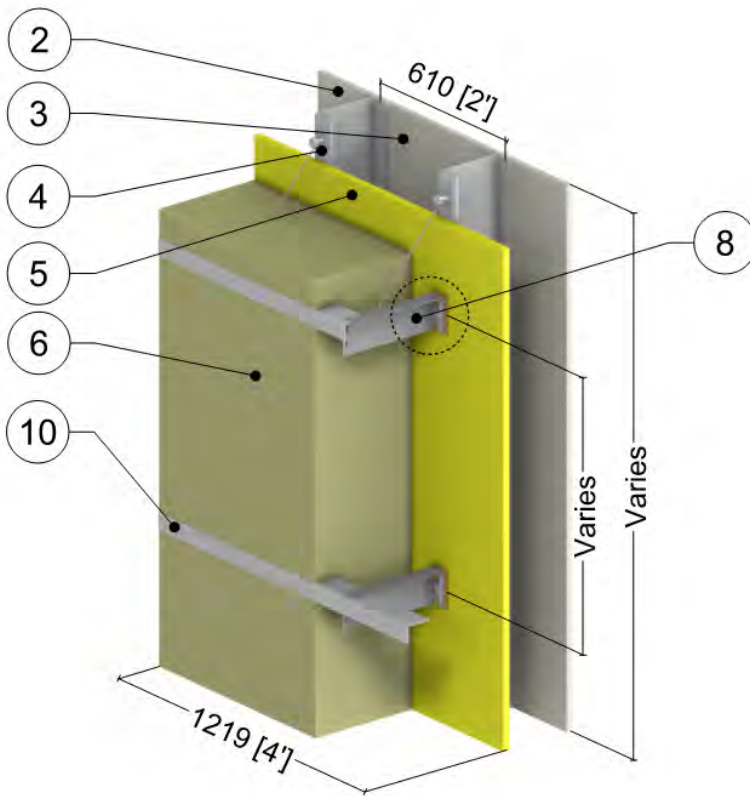

Console Detail

Exterior Insulation Thickness for Console Sizes

Crossfix Console Size	Exterior Insulation Thickness in (mm)
40	2 (51)
80	3.5 (89)
120	5 (127)
200	8.5 (216)
240	10 (254)
320	13 (330)
400	16 (406)

ID	Component	Thickness Inches (mm)	Conductivity Btu-in / ft ² -hr-°F (W/m K)	Nominal Resistance hr-ft ² -°F/Btu (m ² K/W)	Density lb/ft ³ (kg/m ³)	Specific Heat Btu/lb-°F (J/kg K)
1	Interior Film ¹	-	-	R-0.7 (0.12 RSI)	-	-
2	Gypsum Board	1/2" (13)	1.1 (0.16)	R-0.5 (0.09 RSI)	50 (800)	0.26 (1090)
3	Air in Stud Cavity	6" (152)	-	R-0.9 (0.16 RSI)	0.075 (1.2)	0.24 (1000)
4	6" x 1 5/8" Steel Studs	18 Gauge	430 (62)	-	489 (7830)	0.12 (500)
5	Exterior Sheathing	5/8" (16)	1.1 (0.16)	R-0.6 (0.10 RSI)	50 (800)	0.26 (1090)
6	Exterior Mineral Wool Insulation	Varies	0.24 (0.034)	R-8.4 to R-67.2 (1.48 to 11.84 RSI)	4 (64)	0.20 (850)
7	Thermostop	0.2" (5)	2.2 (0.32)	-	69 (1100)	0.36 (1500)
8	EJOT Console and Components	0.06" (1.5)	112 (16)	-	499 (8000)	0.12 (500)
9	Fastener	0.22" (5.5) Ø	112 (16)	-	499 (8000)	0.12 (500)
10	Rail	0.08" (2)	1110 (160)	-	-	-
11	Cladding with 1/2" vented airspace incorporated into exterior heat transfer coefficient					
12	Exterior Film ¹	-	-	R-0.7 (0.12 RSI)	-	-

¹ Value selected from table 1, p. 26.1 of 2009 ASHRAE Handbook – Fundamentals depending on surface orientation

Detail 5.1.102

Exterior and Interior Insulated 6" x 1 5/8" Steel Stud (24" o.c.) Wall Assembly with EJOT Crossfix Console and Horizontal Rail System Supporting Metal Cladding and R-20 Batt Insulation in Stud Cavity - Clear Wall

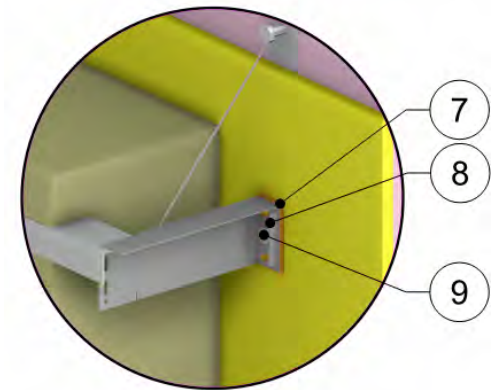
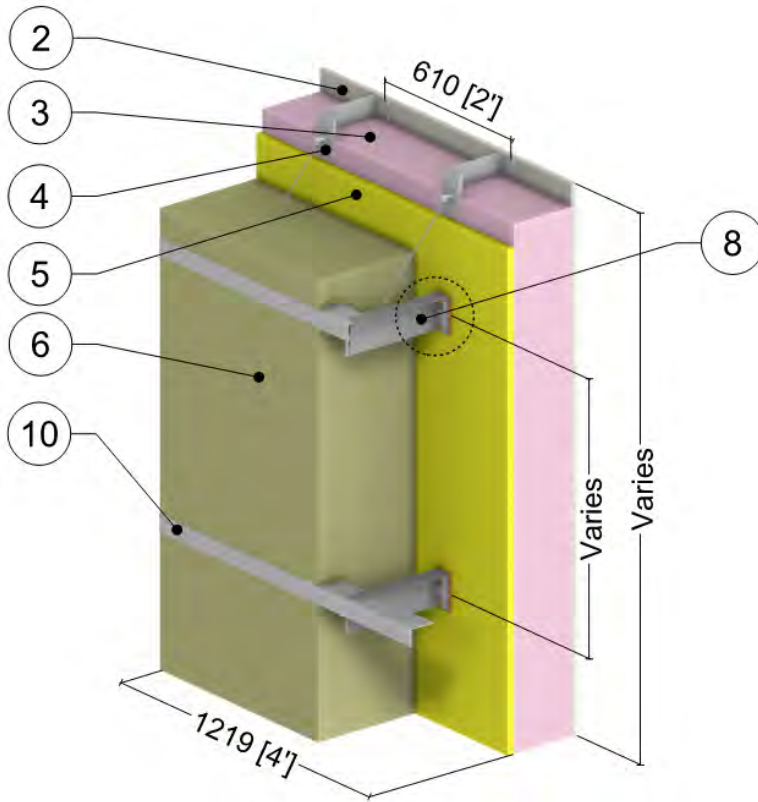

Console Detail

Exterior Insulation Thickness for Console Sizes

Crossfix Console Size	Exterior Insulation Thickness in (mm)
40	2 (51)
80	3.5 (89)
120	5 (127)
200	8.5 (216)
240	10 (254)
320	13 (330)
400	16 (406)

ID	Component	Thickness Inches (mm)	Conductivity Btu-in / ft ² -hr-°F (W/m K)	Nominal Resistance hr-ft ² -°F/Btu (m ² K/W)	Density lb/ft ³ (kg/m ³)	Specific Heat Btu/lb-°F (J/kg K)
1	Interior Film ¹	-	-	R-0.7 (0.12 RSI)	-	-
2	Gypsum Board	1/2" (13)	1.1 (0.16)	R-0.5 (0.09 RSI)	50 (800)	0.26 (1090)
3	Fiberglass Batt Insulation	6" (152)	0.30 (0.043)	R-20 (3.5 RSI)	0.55 (8.8)	0.17 (710)
4	6" x 1 5/8" Steel Studs	18 Gauge	430 (62)	-	489 (7830)	0.12 (500)
5	Exterior Sheathing	5/8" (16)	1.1 (0.16)	R-0.6 (0.10 RSI)	50 (800)	0.26 (1090)
6	Exterior Mineral Wool Insulation	Varies	0.24 (0.034)	R-8.4 to R-67.2 (1.48 to 11.84 RSI)	4 (64)	0.20 (850)
7	Thermostop	0.2" (5)	2.2 (0.32)	-	69 (1100)	0.36 (1500)
8	EJOT Console and Components	0.06" (1.5)	112 (16)	-	499 (8000)	0.12 (500)
9	Fastener	0.22" (5.5) Ø	112 (16)	-	499 (8000)	0.12 (500)
10	Rail	0.08" (2)	1110 (160)	-	-	-
11	Cladding with 1/2" vented airspace incorporated into exterior heat transfer coefficient					
12	Exterior Film ¹	-	-	R-0.7 (0.12 RSI)	-	-

¹ Value selected from table 1, p. 26.1 of 2009 ASHRAE Handbook – Fundamentals depending on surface orientation

Detail 5.1.103

Exterior Insulated 6" x 1 5/8" Steel Stud (16" o.c.) Wall Assembly with EJOT Crossfix Console and Vertical Rail System Supporting Metal Cladding - Clear Wall

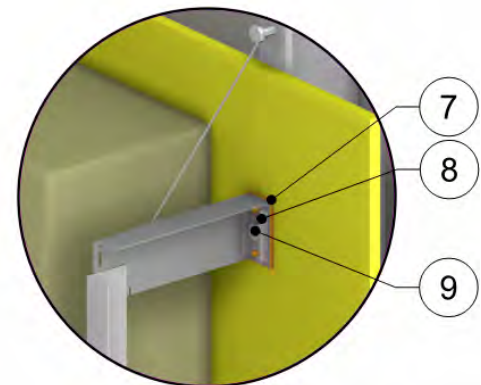
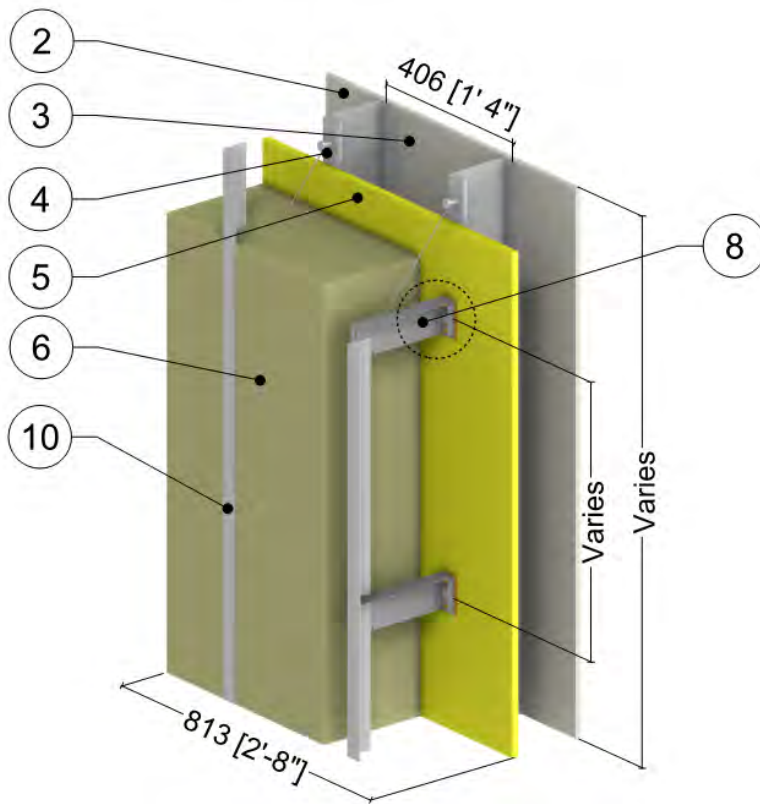

Console Detail

Exterior Insulation Thickness for Console Sizes

Crossfix Console Size	Exterior Insulation Thickness in (mm)
40	2 (51)
80	3.5 (89)
120	5 (127)
200	8.5 (216)
240	10 (254)
320	13 (330)
400	16 (406)

ID	Component	Thickness Inches (mm)	Conductivity Btu-in / ft ² -hr-°F (W/m K)	Nominal Resistance hr-ft ² -°F/Btu (m ² K/W)	Density lb/ft ³ (kg/m ³)	Specific Heat Btu/lb-°F (J/kg K)
1	Interior Film ¹	-	-	R-0.7 (0.12 RSI)	-	-
2	Gypsum Board	1/2" (13)	1.1 (0.16)	R-0.5 (0.09 RSI)	50 (800)	0.26 (1090)
3	Air in Stud Cavity	6" (152)	-	R-0.9 (0.16 RSI)	0.075 (1.2)	0.24 (1000)
4	6" x 1 5/8" Steel Studs	18 Gauge	430 (62)	-	489 (7830)	0.12 (500)
5	Exterior Sheathing	5/8" (16)	1.1 (0.16)	R-0.6 (0.10 RSI)	50 (800)	0.26 (1090)
6	Exterior Mineral Wool Insulation	Varies	0.24 (0.034)	R-8.4 to R-67.2 (1.48 to 11.84 RSI)	4 (64)	0.20 (850)
7	Thermostop	0.2" (5)	2.2 (0.32)	-	69 (1100)	0.36 (1500)
8	EJOT Console and Components	0.06" (1.5)	112 (16)	-	499 (8000)	0.12 (500)
9	Fastener	0.22" (5.5) Ø	112 (16)	-	499 (8000)	0.12 (500)
10	Rail	0.08" (2)	1110 (160)	-	-	-
11	Cladding with 1/2" vented airspace incorporated into exterior heat transfer coefficient					
12	Exterior Film ¹	-	-	R-0.7 (0.12 RSI)	-	-

¹ Value selected from table 1, p. 26.1 of 2009 ASHRAE Handbook – Fundamentals depending on surface orientation

Detail 5.1.104

Exterior and Interior Insulated 6" x 1 5/8" Steel Stud (16" o.c.) Wall Assembly with EJOT Crossfix Console and Vertical Rail System Supporting Metal Cladding and R-20 Batt Insulation in Stud Cavity - Clear Wall

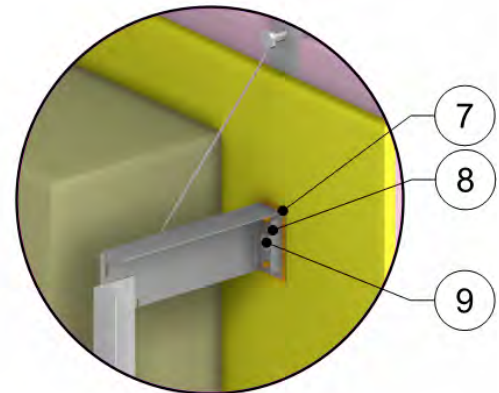
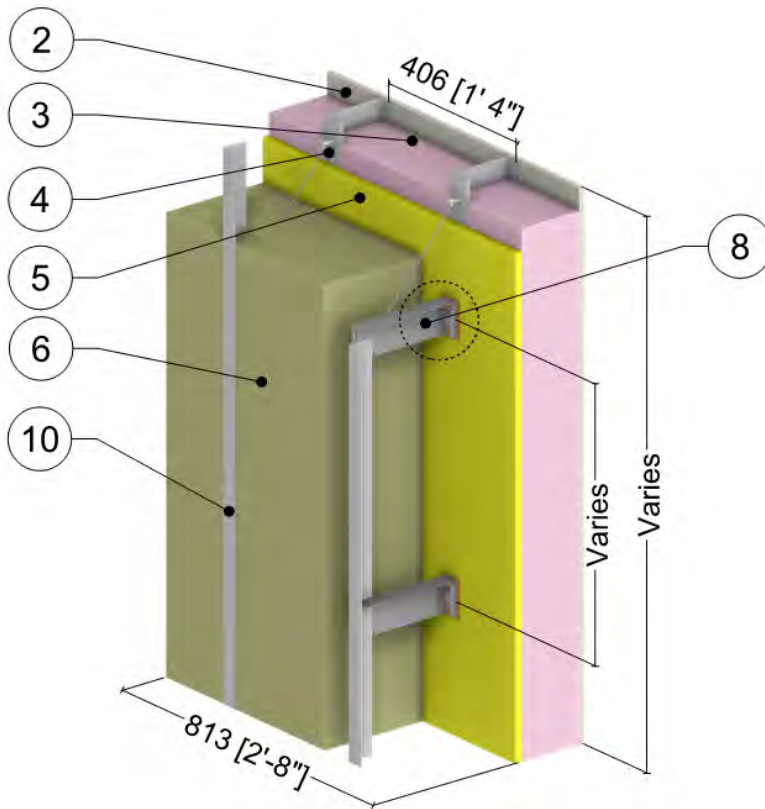

Console Detail

Exterior Insulation Thickness for Console Sizes

Crossfix Console Size	Exterior Insulation Thickness in (mm)
40	2 (51)
80	3.5 (89)
120	5 (127)
200	8.5 (216)
240	10 (254)
320	13 (330)
400	16 (406)

ID	Component	Thickness Inches (mm)	Conductivity Btu·in / ft ² ·hr·°F (W/m K)	Nominal Resistance hr·ft ² ·°F/Btu (m ² K/W)	Density lb/ft ³ (kg/m ³)	Specific Heat Btu/lb·°F (J/kg K)
1	Interior Film ¹	-	-	R-0.7 (0.12 RSI)	-	-
2	Gypsum Board	1/2" (13)	1.1 (0.16)	R-0.5 (0.09 RSI)	50 (800)	0.26 (1090)
3	Fiberglass Batt Insulation	6" (152)	0.30 (0.043)	R-20 (3.5 RSI)	0.55 (8.8)	0.17 (710)
4	6" x 1 5/8" Steel Studs	18 Gauge	430 (62)	-	489 (7830)	0.12 (500)
5	Exterior Sheathing	5/8" (16)	1.1 (0.16)	R-0.6 (0.10 RSI)	50 (800)	0.26 (1090)
6	Exterior Mineral Wool Insulation	Varies	0.24 (0.034)	R-8.4 to R-67.2 (1.48 to 11.84 RSI)	4 (64)	0.20 (850)
7	Thermostop	0.2" (5)	2.2 (0.32)	-	69 (1100)	0.36 (1500)
8	EJOT Console and Components	0.06" (1.5)	112 (16)	-	499 (8000)	0.12 (500)
9	Fastener	0.22" (5.5) Ø	112 (16)	-	499 (8000)	0.12 (500)
10	Rail	0.08" (2)	1110 (160)	-	-	-
11	Cladding with 1/2" vented airspace incorporated into exterior heat transfer coefficient					
12	Exterior Film ¹	-	-	R-0.7 (0.12 RSI)	-	-

¹ Value selected from table 1, p. 26.1 of 2009 ASHRAE Handbook – Fundamentals depending on surface orientation

Detail 5.1.105

Exterior Insulated 6" x 1 5/8" Steel Stud (24" o.c.) Wall Assembly with EJOT Crossfix Console and Vertical Rail System Supporting Metal Cladding - Clear Wall

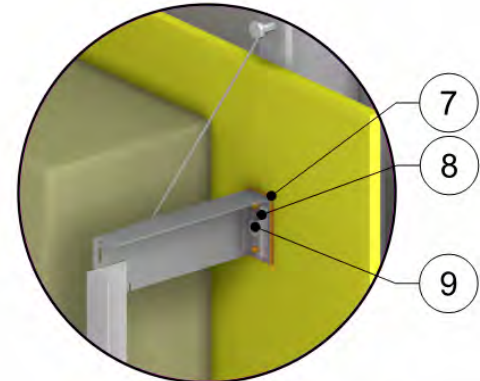
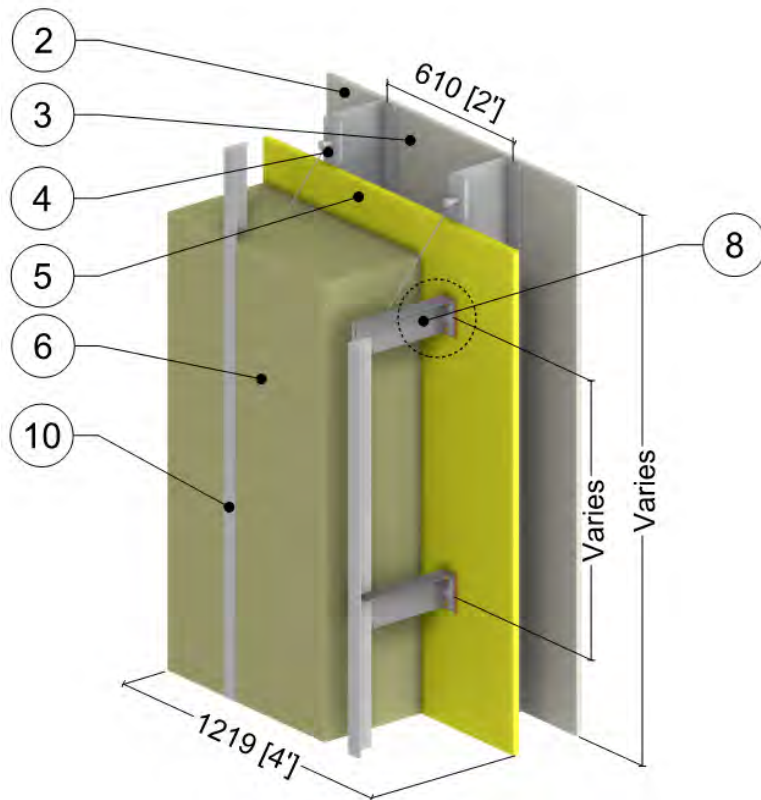

Console Detail

Exterior Insulation Thickness for Console Sizes

Crossfix Console Size	Exterior Insulation Thickness in (mm)
40	2 (51)
80	3.5 (89)
120	5 (127)
200	8.5 (216)
240	10 (254)
320	13 (330)
400	16 (406)

ID	Component	Thickness Inches (mm)	Conductivity Btu-in / ft ² -hr-°F (W/m K)	Nominal Resistance hr-ft ² -°F/Btu (m ² K/W)	Density lb/ft ³ (kg/m ³)	Specific Heat Btu/lb-°F (J/kg K)
1	Interior Film ¹	-	-	R-0.7 (0.12 RSI)	-	-
2	Gypsum Board	1/2" (13)	1.1 (0.16)	R-0.5 (0.09 RSI)	50 (800)	0.26 (1090)
3	Air in Stud Cavity	6" (152)	-	R-0.9 (0.16 RSI)	0.075 (1.2)	0.24 (1000)
4	6" x 1 5/8" Steel Studs	18 Gauge	430 (62)	-	489 (7830)	0.12 (500)
5	Exterior Sheathing	5/8" (16)	1.1 (0.16)	R-0.6 (0.10 RSI)	50 (800)	0.26 (1090)
6	Exterior Mineral Wool Insulation	Varies	0.24 (0.034)	R-8.4 to R-67.2 (1.48 to 11.84 RSI)	4 (64)	0.20 (850)
7	Thermostop	0.2" (5)	2.2 (0.32)	-	69 (1100)	0.36 (1500)
8	EJOT Console and Components	0.06" (1.5)	112 (16)	-	499 (8000)	0.12 (500)
9	Fastener	0.22" (5.5) Ø	112 (16)	-	499 (8000)	0.12 (500)
10	Rail	0.08" (2)	1110 (160)	-	-	-
11	Cladding with 1/2" vented airspace incorporated into exterior heat transfer coefficient					
12	Exterior Film ¹	-	-	R-0.7 (0.12 RSI)	-	-

¹ Value selected from table 1, p. 26.1 of 2009 ASHRAE Handbook – Fundamentals depending on surface orientation

Detail 5.1.106

Exterior and Interior Insulated 6" x 1 5/8" Steel Stud (24" o.c.) Wall Assembly with EJOT Crossfix Console and Vertical Rail System Supporting Metal Cladding and R-20 Batt Insulation in Stud Cavity - Clear Wall

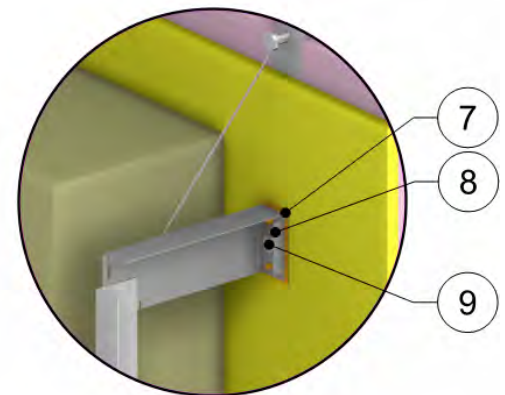
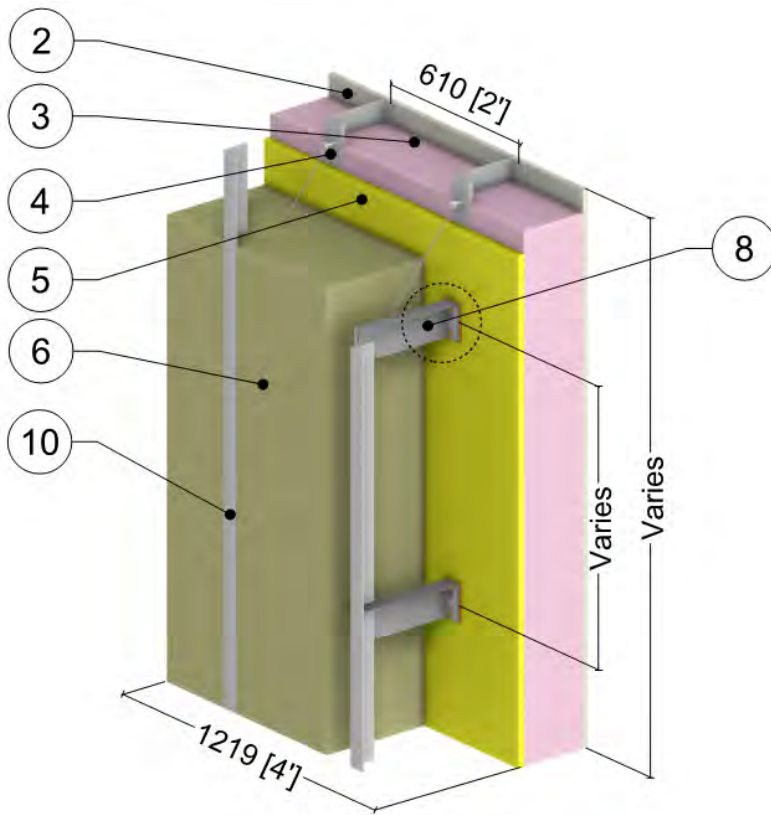

Console Detail

Exterior Insulation Thickness for Console Sizes

Crossfix Console Size	Exterior Insulation Thickness in (mm)
40	2 (51)
80	3.5 (89)
120	5 (127)
200	8.5 (216)
240	10 (254)
320	13 (330)
400	16 (406)

ID	Component	Thickness Inches (mm)	Conductivity Btu-in / ft ² -hr-°F (W/m K)	Nominal Resistance hr-ft ² -°F/Btu (m ² K/W)	Density lb/ft ³ (kg/m ³)	Specific Heat Btu/lb-°F (J/kg K)
1	Interior Film ¹	-	-	R-0.7 (0.12 RSI)	-	-
2	Gypsum Board	1/2" (13)	1.1 (0.16)	R-0.5 (0.09 RSI)	50 (800)	0.26 (1090)
3	Fiberglass Batt Insulation	6" (152)	0.30 (0.043)	R-20 (3.5 RSI)	0.55 (8.8)	0.17 (710)
4	6" x 1 5/8" Steel Studs	18 Gauge	430 (62)	-	489 (7830)	0.12 (500)
5	Exterior Sheathing	5/8" (16)	1.1 (0.16)	R-0.6 (0.10 RSI)	50 (800)	0.26 (1090)
6	Exterior Mineral Wool Insulation	Varies	0.24 (0.034)	R-8.4 to R-67.2 (1.48 to 11.84 RSI)	4 (64)	0.20 (850)
7	Thermostop	0.2" (5)	2.2 (0.32)	-	69 (1100)	0.36 (1500)
8	EJOT Console and Components	0.06" (1.5)	112 (16)	-	499 (8000)	0.12 (500)
9	Fastener	0.22" (5.5) Ø	112 (16)	-	499 (8000)	0.12 (500)
10	Rail	0.08" (2)	1110 (160)	-	-	-
11	Cladding with 1/2" vented airspace incorporated into exterior heat transfer coefficient					
12	Exterior Film ¹	-	-	R-0.7 (0.12 RSI)	-	-

¹ Value selected from table 1, p. 26.1 of 2009 ASHRAE Handbook – Fundamentals depending on surface orientation

Detail 5.1.107

Exterior Insulated 6" x 1 5/8" Steel Stud (16" o.c.) Wall Assembly with Horizontal Z-Girts (24" o.c.) Supporting Cladding and Owens Corning ThermaFiber RainBarrier HC Max Insulation – Clear Wall

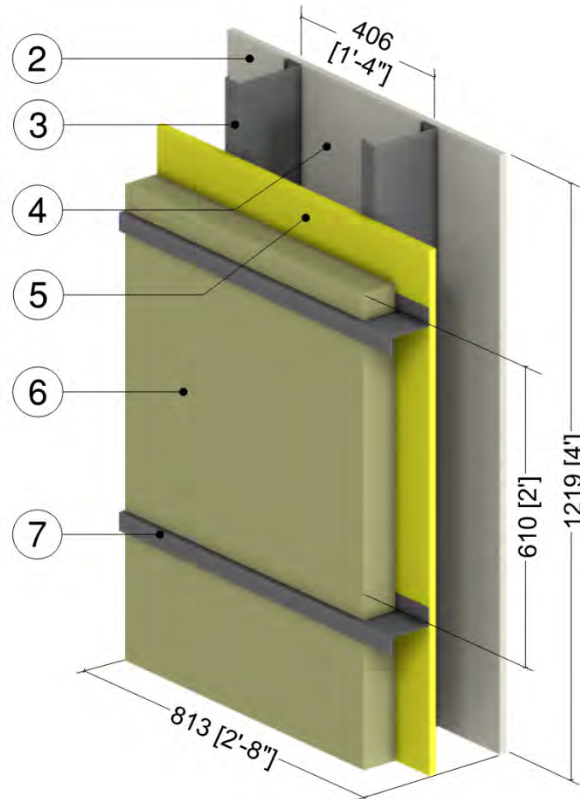

ID	Component	Thickness Inches (mm)	Conductivity Btu-in / ft ² ·hr·°F (W/m K)	Nominal Resistance hr·ft ² ·°F/Btu (m ² K/W)	Density lb/ft ³ (kg/m ³)	Specific Heat Btu/lb·°F (J/kg K)
1	Interior Film ¹	-	-	R-0.7 (0.12 RSI)	-	-
2	Gypsum Board	5/8" (16)	1.1 (0.16)	R-0.6 (0.10 RSI)	50 (800)	0.26 (1090)
3	6" x 1 5/8" Steel Studs	18 Gauge	430 (62)	-	489 (7830)	0.12 (500)
4	Air in Stud Cavity	6" (152)	-	R-0.9 (0.16 RSI)	0.075 (1.2)	0.24 (1000)
5	Exterior Sheathing	5/8" (16)	1.1 (0.16)	R-0.6 (0.10 RSI)	50 (800)	0.26 (1090)
6	ThermaFiber RainBarrier HC Max Mineral Wool Semi Rigid Insulation	Varies	0.25 (0.036)	R-4 to R-24 (0.70 to 4.23 RSI)	11 (176)	0.20 (850)
7	Horizontal Z-Girts with 1-1/2" Flange	18 gauge	430 (62)	-	489 (7830)	0.12 (500)
8	Metal Cladding with 1/2" (13 mm) vented airspace incorporated into exterior heat transfer coefficient					
9	Exterior Film ¹	-	-	R-0.7 (0.12 RSI)	-	-

¹ Value selected from table 1, p. 26.1 of 2009 ASHRAE Handbook – Fundamentals depending on surface orientation

Detail 5.1.108

Exterior Insulated 6" x 1 5/8" Steel Stud (16" o.c.) Wall Assembly with High Compression Insulation and Through Insulation Steel Fasteners (12" o.c.) Supporting Cladding, Owens Corning ThermaFiber RainBarrier HC Max Insulation – Clear Wall

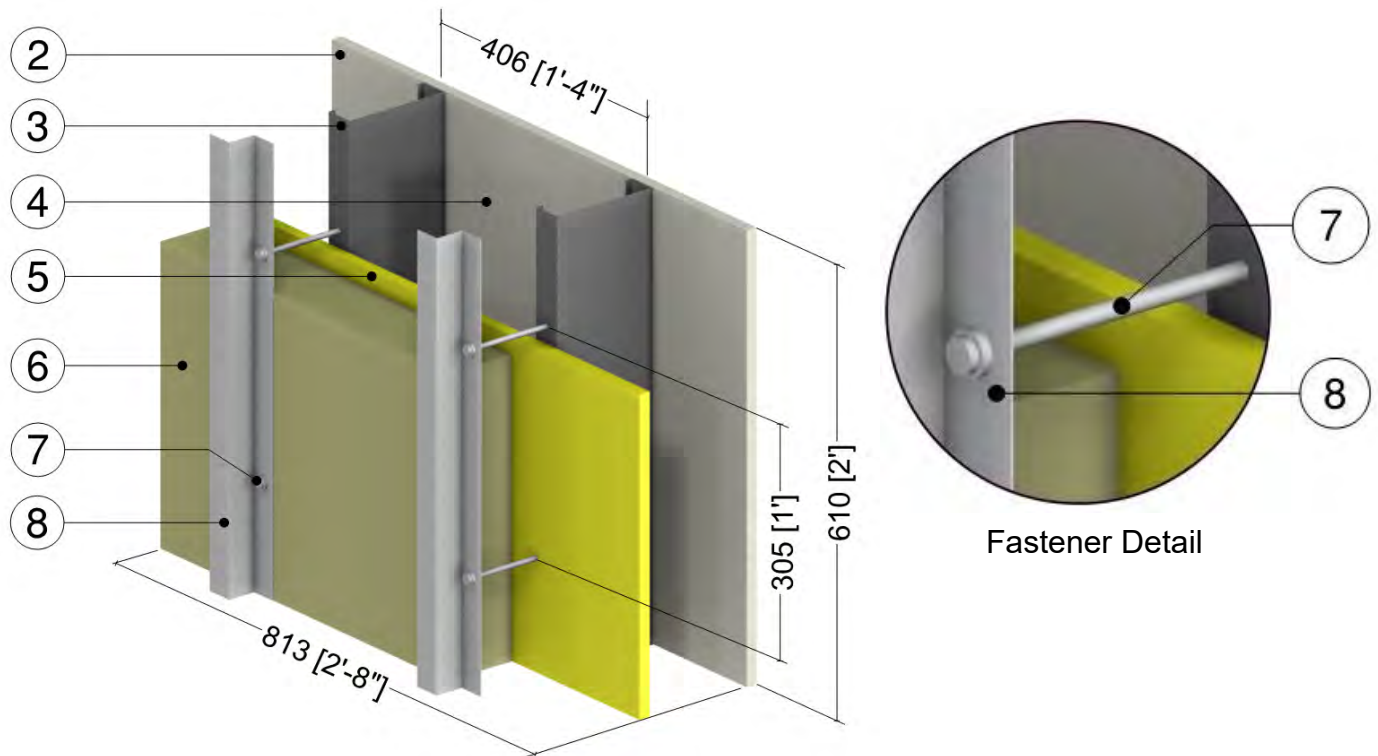

ID	Component	Thickness Inches (mm)	Conductivity Btu·in / ft ² ·hr·°F (W/m K)	Nominal Resistance hr·ft ² ·°F/Btu (m ² K/W)	Density lb/ft ³ (kg/m ³)	Specific Heat Btu/lb·°F (J/kg K)
1	Interior Film ¹	-	-	R-0.7 (0.12 RSI)	-	-
2	Gypsum Board	5/8" (16)	1.1 (0.16)	R-0.6 (0.10 RSI)	50 (800)	0.26 (1090)
3	6" x 1 5/8" Steel Studs	18 Gauge	430 (62)	-	489 (7830)	0.12 (500)
4	Air in Stud Cavity	6" (152)	-	R-0.9 (0.16 RSI)	0.075 (1.2)	0.24 (1000)
5	Exterior Sheathing	5/8" (16)	1.1 (0.16)	R-0.6 (0.10 RSI)	50 (800)	0.26 (1090)
6	ThermaFiber RainBarrier HC Max Mineral Wool Semi Rigid Insulation	Varies	0.25 (0.036)	R-4.0 to R-16.0 (0.70 to 2.82 RSI)	11 (176)	0.20 (850)
7	#12 Steel Fasteners (12" o.c.)	0.21" (5.3) Ø	430 (62)	-	489 (7830)	0.12 (500)
8	Vertical Z-Girts	18 Gauge	430 (62)	-	489 (7830)	0.12 (500)
9	Metal Cladding with 1/2" (13 mm) vented airspace incorporated into exterior heat transfer coefficient					
10	Exterior Film ¹	-	-	R-0.7 (0.12 RSI)	-	-

¹ Value selected from table 1, p. 26.1 of 2009 ASHRAE Handbook – Fundamentals depending on surface orientation

Detail 5.1.109

Exterior Insulated 6" x 1 5/8" Steel Stud (16" o.c.) Wall Assembly with High Compression Insulation and Through Insulation Steel Fasteners (12" o.c.) Supporting Cladding, Owens Corning ThermaFiber RainBarrier Ci HC 80/45 Insulation – Clear Wall

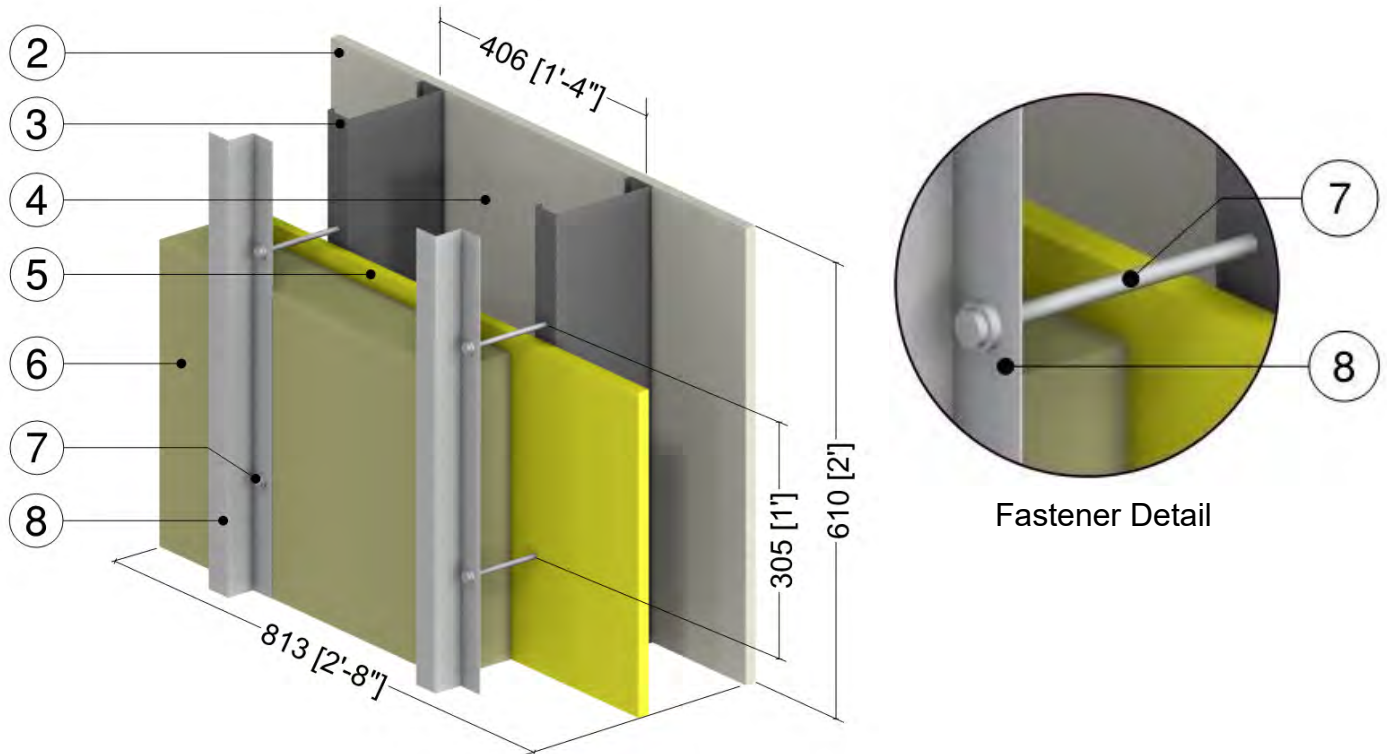

ID	Component	Thickness Inches (mm)	Conductivity Btu-in / ft ² -hr-°F (W/m K)	Nominal Resistance hr-ft ² -°F/Btu (m ² K/W)	Density lb/ft ³ (kg/m ³)	Specific Heat Btu/lb-°F (J/kg K)
1	Interior Film ¹	-	-	R-0.7 (0.12 RSI)	-	-
2	Gypsum Board	5/8" (16)	1.1 (0.16)	R-0.6 (0.10 RSI)	50 (800)	0.26 (1090)
3	6" x 1 5/8" Steel Studs	18 Gauge	430 (62)	-	489 (7830)	0.12 (500)
4	Air in Stud Cavity	6" (152)	-	R-0.9 (0.16 RSI)	0.075 (1.2)	0.24 (1000)
5	Exterior Sheathing	5/8" (16)	1.1 (0.16)	R-0.6 (0.10 RSI)	50 (800)	0.26 (1090)
6	ThermaFiber RainBarrier Ci HC 80/45 Mineral Wool Semi Rigid Insulation	Varies	0.24 (0.034)	R-4.2 to R-16.8 (0.74 to 2.96 RSI)	4.5 (72)	0.20 (850)
7	#12 Steel Fasteners (12" o.c.)	0.21" (5.3) Ø	430 (62)	-	489 (7830)	0.12 (500)
8	Vertical Z-Girts	18 Gauge	430 (62)	-	489 (7830)	0.12 (500)
9	Metal Cladding with 1/2" (13 mm) vented airspace incorporated into exterior heat transfer coefficient					
10	Exterior Film ¹	-	-	R-0.7 (0.12 RSI)	-	-

¹ Value selected from table 1, p. 26.1 of 2009 ASHRAE Handbook – Fundamentals depending on surface orientation

Detail 5.1.110

**Exterior Insulated 6" x 1 5/8" Steel Stud (16" o.c.) Wall Assembly with High Compression Insulation and Through Insulation
Stainless Steel Fasteners (12" o.c.) Supporting Cladding, Owens Corning ThermaFiber RainBarrier HC Max Insulation – Clear Wall**

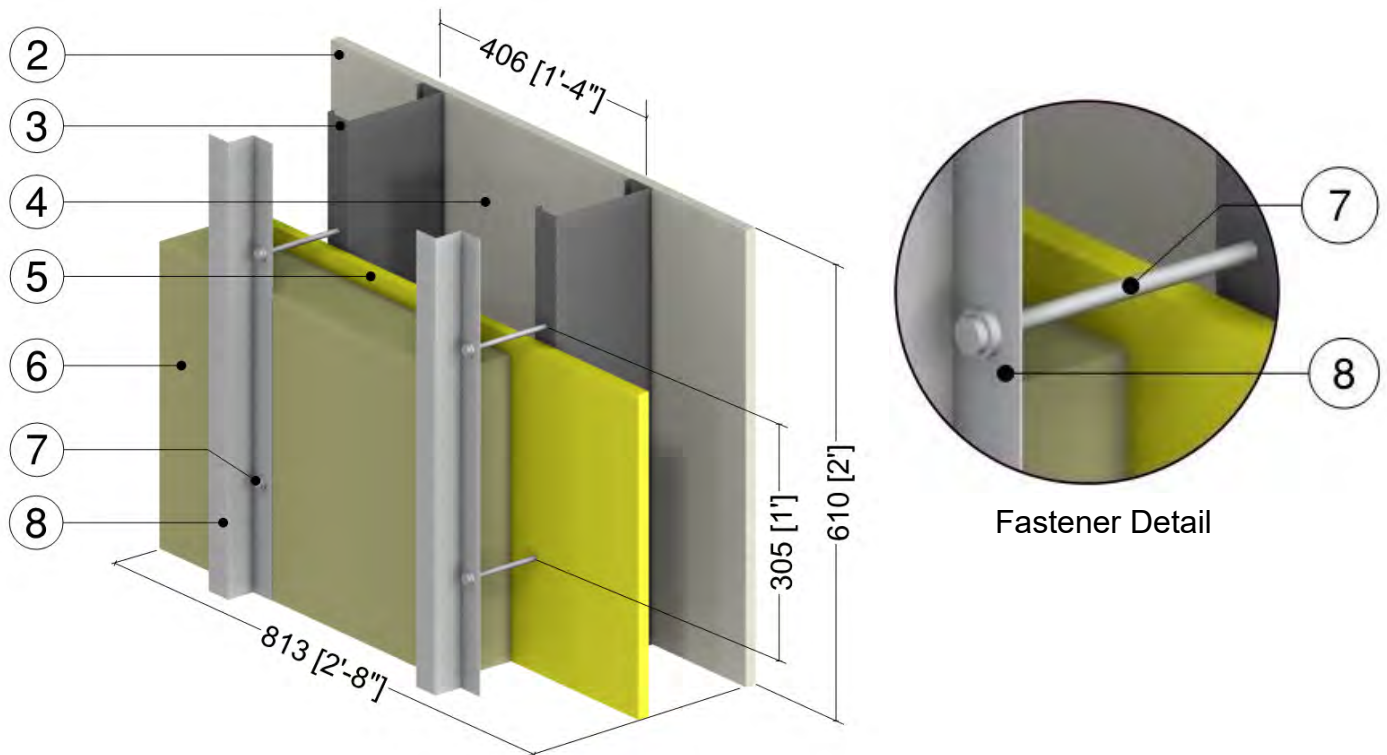

ID	Component	Thickness Inches (mm)	Conductivity Btu·in / ft ² ·hr·°F (W/m K)	Nominal Resistance hr·ft ² ·°F/Btu (m ² K/W)	Density lb/ft ³ (kg/m ³)	Specific Heat Btu/lb·°F (J/kg K)
1	Interior Film ¹	-	-	R-0.7 (0.12 RSI)	-	-
2	Gypsum Board	5/8" (16)	1.1 (0.16)	R-0.6 (0.10 RSI)	50 (800)	0.26 (1090)
3	6" x 1 5/8" Steel Studs	18 Gauge	430 (62)	-	489 (7830)	0.12 (500)
4	Air in Stud Cavity	6" (152)	-	R-0.9 (0.16 RSI)	0.075 (1.2)	0.24 (1000)
5	Exterior Sheathing	5/8" (16)	1.1 (0.16)	R-0.6 (0.10 RSI)	50 (800)	0.26 (1090)
6	ThermaFiber RainBarrier HC Max Mineral Wool Semi Rigid Insulation	Varies	0.25 (0.036)	R-4.0 to R-16.0 (0.70 to 2.82 RSI)	11 (176)	0.20 (850)
7	#12 Stainless Steel Fasteners (12" o.c.)	0.21" (5.3) Ø	118 (17)	-	500 (8000)	0.12 (500)
8	Vertical Z-Girts	18 Gauge	430 (62)	-	489 (7830)	0.12 (500)
9	Metal Cladding with 1/2" (13 mm) vented airspace incorporated into exterior heat transfer coefficient					
10	Exterior Film ¹	-	-	R-0.7 (0.12 RSI)	-	-

¹ Value selected from table 1, p. 26.1 of 2009 ASHRAE Handbook – Fundamentals depending on surface orientation

Detail 5.1.111

**Exterior Insulated 6" x 1 5/8" Steel Stud (16" o.c.) Wall Assembly with High Compression Insulation and Through Insulation
Stainless Steel Fasteners (12" o.c.) Supporting Cladding, Owens Corning ThermaFiber RainBarrier Ci HC 80/45 Insulation – Clear Wall**

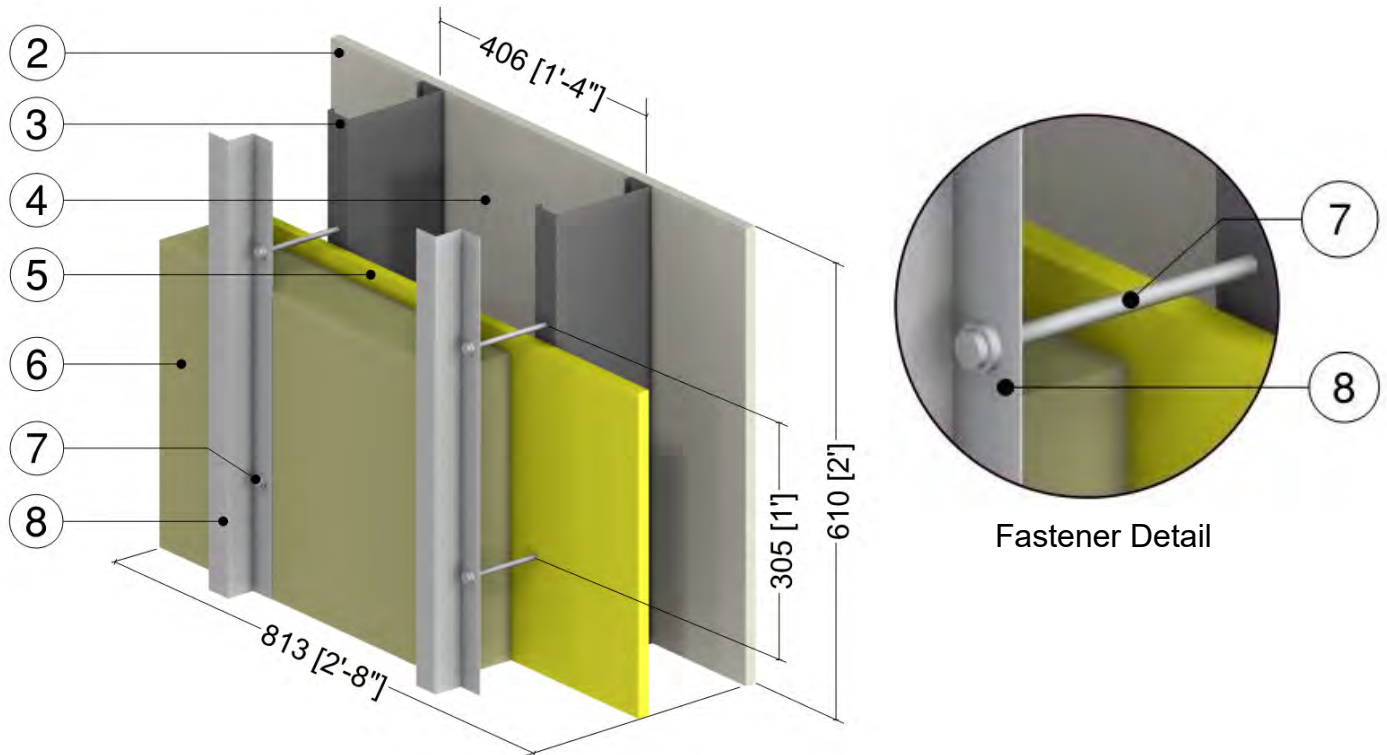

ID	Component	Thickness Inches (mm)	Conductivity Btu-in / ft ² ·hr·°F (W/m K)	Nominal Resistance hr·ft ² ·°F/Btu (m ² K/W)	Density lb/ft ³ (kg/m ³)	Specific Heat Btu/lb·°F (J/kg K)
1	Interior Film ¹	-	-	R-0.7 (0.12 RSI)	-	-
2	Gypsum Board	5/8" (16)	1.1 (0.16)	R-0.6 (0.10 RSI)	50 (800)	0.26 (1090)
3	6" x 1 5/8" Steel Studs	18 Gauge	430 (62)	-	489 (7830)	0.12 (500)
4	Air in Stud Cavity	6" (152)	-	R-0.9 (0.16 RSI)	0.075 (1.2)	0.24 (1000)
5	Exterior Sheathing	5/8" (16)	1.1 (0.16)	R-0.6 (0.10 RSI)	50 (800)	0.26 (1090)
6	ThermaFiber RainBarrier Ci HC 80/45 Mineral Wool Semi Rigid Insulation	Varies	0.24 (0.034)	R-4.2 to R-16.8 (0.74 to 2.96 RSI)	4.5 (72)	0.20 (850)
7	#12 Stainless Steel Fasteners (12" o.c.)	0.21" (5.3) Ø	118 (17)	-	500 (8000)	0.12 (500)
8	Vertical Z-Girts	18 Gauge	430 (62)	-	489 (7830)	0.12 (500)
9	Metal Cladding with 1/2" (13 mm) vented airspace incorporated into exterior heat transfer coefficient					
10	Exterior Film ¹	-	-	R-0.7 (0.12 RSI)	-	-

¹ Value selected from table 1, p. 26.1 of 2009 ASHRAE Handbook – Fundamentals depending on surface orientation

Detail 5.1.112 Exterior and Interior Insulated 6" x 1 5/8" Steel Stud (16" o.c.) Wall Assembly with High Compression Insulation and Through Insulation Stainless Steel Fasteners (16" o.c.) Supporting Cladding, Owens Corning ThermaFiber RainBarrier HC Max Insulation and R-20 Batt Insulation in Stud Cavity – Clear Wall

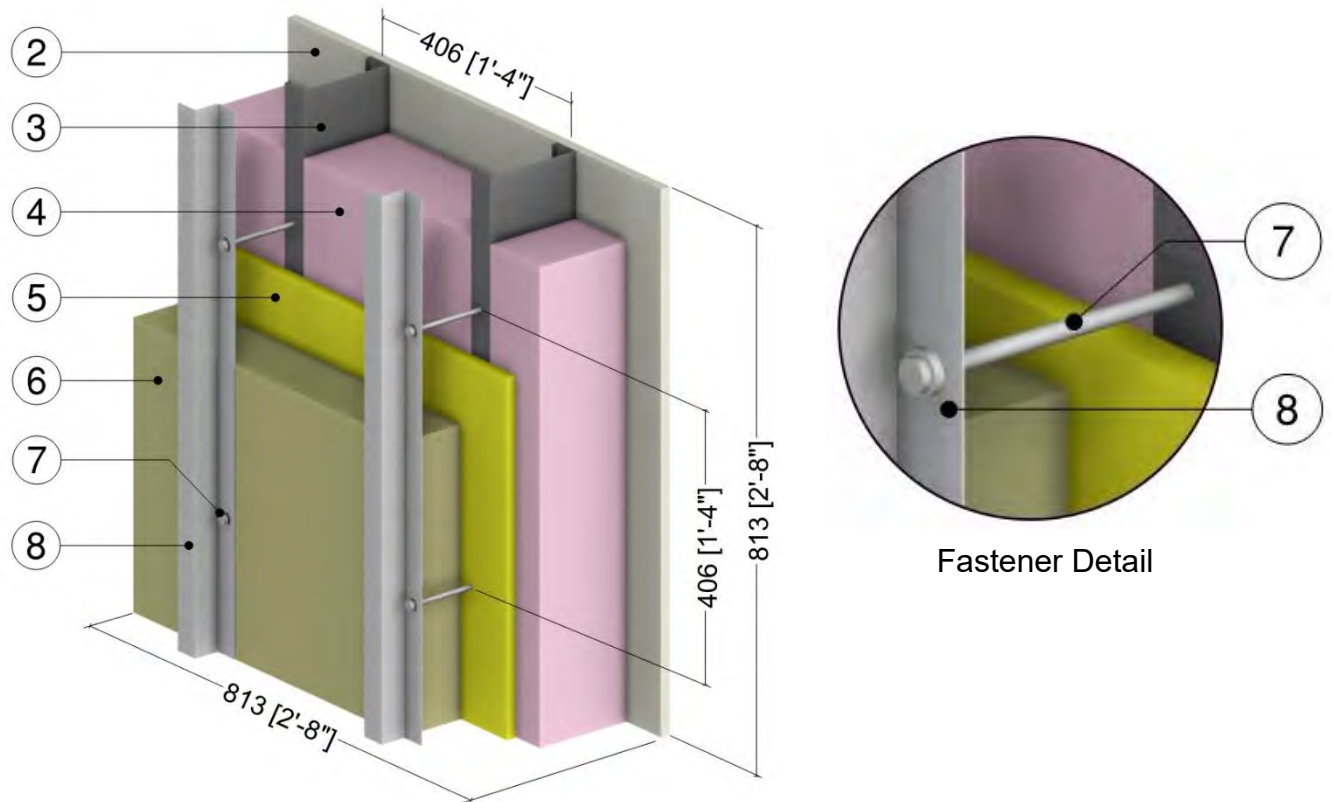

ID	Component	Thickness Inches (mm)	Conductivity Btu-in / ft ² -hr-°F (W/m K)	Nominal Resistance hr-ft ² -°F/Btu (m ² K/W)	Density lb/ft ³ (kg/m ³)	Specific Heat Btu/lb-°F (J/kg K)
1	Interior Film ¹	-	-	R-0.7 (0.12 RSI)	-	-
2	Gypsum Board	5/8" (16)	1.1 (0.16)	R-0.6 (0.10 RSI)	50 (800)	0.26 (1090)
3	6" x 1 5/8" Steel Studs	18 Gauge	430 (62)	-	489 (7830)	0.12 (500)
4	Ecotouch Pink Fiberglass Batt	6" (152)	0.28 (0.041)	R-20 (3.52 RSI)	0.55 (8.8)	0.17 (710)
5	Exterior Sheathing	5/8" (16)	1.1 (0.16)	R-0.6 (0.10 RSI)	50 (800)	0.26 (1090)
6	ThermaFiber RainBarrier HC Max Mineral Wool Semi Rigid Insulation	Varies	0.25 (0.036)	R-4.0 to R-16.0 (0.70 to 2.82 RSI)	11 (176)	0.20 (850)
7	#12 Stainless Steel Fasteners (16" o.c.)	0.21" (5.3) Ø	118 (17)	-	500 (8000)	0.12 (500)
8	Vertical Z-Girts	18 Gauge	430 (62)	-	489 (7830)	0.12 (500)
9	Metal Cladding with 1/2" (13 mm) vented airspace incorporated into exterior heat transfer coefficient					
10	Exterior Film ¹	-	-	R-0.7 (0.12 RSI)	-	-

¹ Value selected from table 1, p. 26.1 of 2009 ASHRAE Handbook – Fundamentals depending on surface orientation

Detail 5.1.113

Exterior and Interior Insulated 6" x 1 5/8" Steel Stud (16" o.c.) Wall Assembly with High Compression Insulation and Through Insulation Stainless Steel Fasteners (16" o.c.) Supporting Cladding, Owens Corning ThermaFiber RainBarrier Ci HC 80/45 Insulation and R-20 Batt Insulation in Stud Cavity – Clear Wall

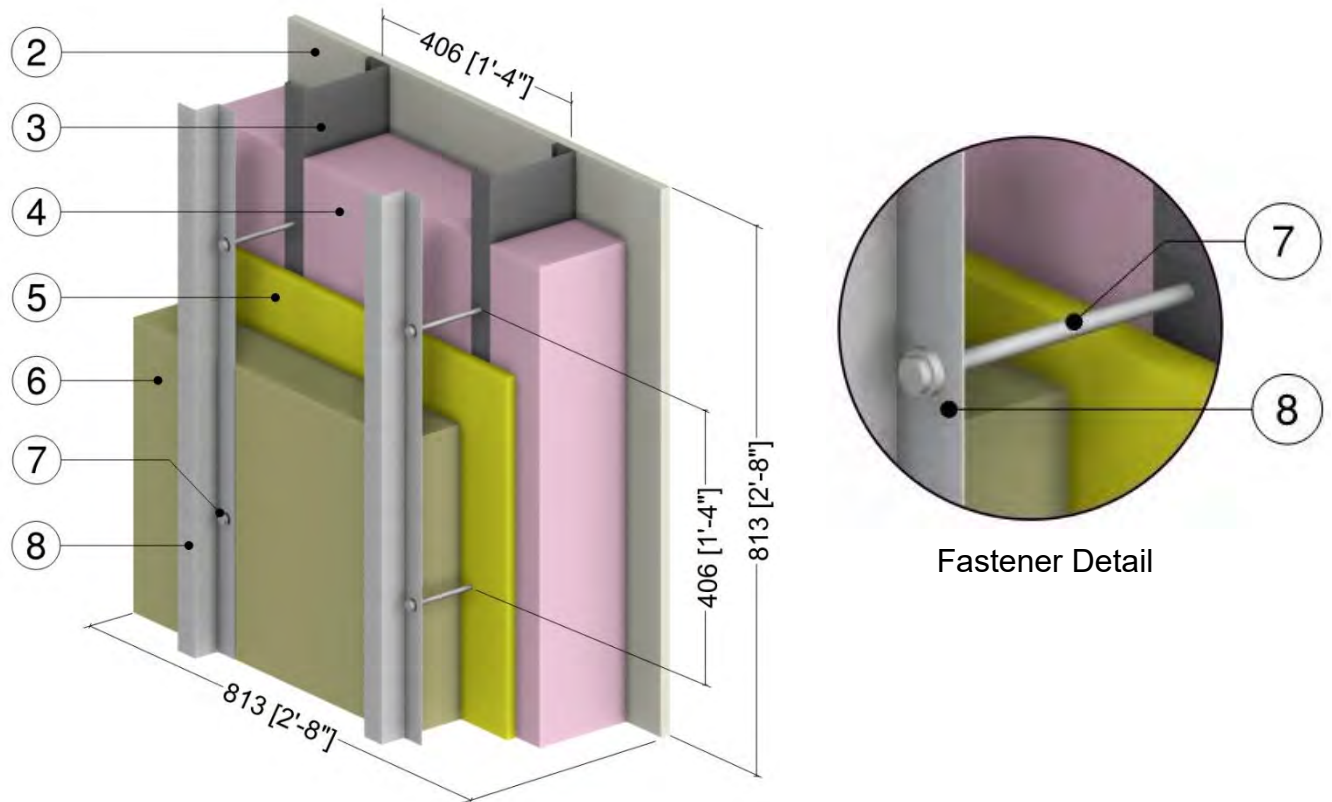

ID	Component	Thickness Inches (mm)	Conductivity Btu-in / ft ² -hr-°F (W/m K)	Nominal Resistance hr-ft ² -°F/Btu (m ² K/W)	Density lb/ft ³ (kg/m ³)	Specific Heat Btu/lb-°F (J/kg K)
1	Interior Film ¹	-	-	R-0.7 (0.12 RSI)	-	-
2	Gypsum Board	5/8" (16)	1.1 (0.16)	R-0.6 (0.10 RSI)	50 (800)	0.26 (1090)
3	6" x 1 5/8" Steel Studs	18 Gauge	430 (62)	-	489 (7830)	0.12 (500)
4	Ecotouch Pink Fiberglass Batt	6" (152)	0.28 (0.041)	R-20 (3.52 RSI)	0.55 (8.8)	0.17 (710)
5	Exterior Sheathing	5/8" (16)	1.1 (0.16)	R-0.6 (0.10 RSI)	50 (800)	0.26 (1090)
6	ThermaFiber RainBarrier Ci HC 80/45 Mineral Wool Semi Rigid Insulation	Varies	0.24 (0.034)	R-4.2 to R-16.8 (0.74 to 2.96 RSI)	4.5 (72)	0.20 (850)
7	#12 Stainless Steel Fasteners (16" o.c.)	0.21" (5.3) Ø	118 (17)	-	500 (8000)	0.12 (500)
8	Vertical Z-Girts	18 Gauge	430 (62)	-	489 (7830)	0.12 (500)
9	Metal Cladding with 1/2" (13 mm) vented airspace incorporated into exterior heat transfer coefficient					
10	Exterior Film ¹	-	-	R-0.7 (0.12 RSI)	-	-

¹ Value selected from table 1, p. 26.1 of 2009 ASHRAE Handbook – Fundamentals depending on surface orientation

Detail 5.1.114 Exterior and Interior Insulated Wall Assembly with Brick Ties Supporting Brick Veneer and R-12 Batt Insulation in Stud Cavity – Clear Wall

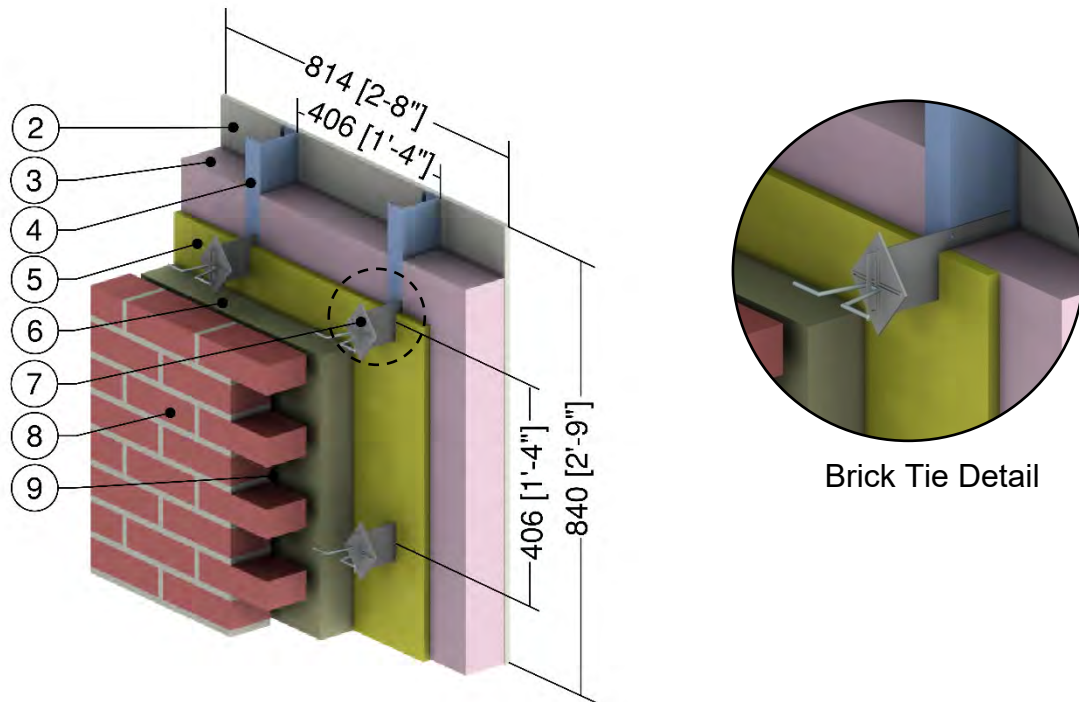

ID	Component	Thickness Inches (mm)	Conductivity Btu-in / ft ² ·hr·°F (W/m K)	Nominal Resistance hr·ft ² ·°F/Btu (m ² K/W)	Density lb/ft ³ (kg/m ³)	Specific Heat Btu/lb·°F (J/kg K)
1	Interior Film ¹	-	-	R-0.7 (0.12 RSI)	-	-
2	Gypsum Board	1/2" (13)	1.1 (0.16)	R-0.5 (0.08 RSI)	50 (800)	0.26 (1090)
3	Fiberglass Batt Insulation	3 5/8" (92)	0.30 (0.044)	R-12 (2.1 RSI)	0.9 (14)	0.17 (710)
4	3 5/8" x 1 5/8" Steel Studs	18 Gauge	430 (62)	-	489 (7830)	0.12 (500)
5	Exterior Sheathing	1/2" (13)	1.1 (0.16)	R-0.5 (0.08 RSI)	50 (800)	0.26 (1090)
6	Exterior Insulation	Varies	-	R-5 to R-25 (0.88 RSI to 4.4 RSI)	1.8 (28)	0.29 (1220)
7	Brick Ties	14 Gauge	347 (50)	-	489 (7830)	0.12 (500)
8	Brick Veneer	3 5/8" (92)	5.4 (0.78)	-	120 (1920)	0.19 (720)
9	Air Gap	1" (25)	-	R-0.9 (0.16 RSI)	0.075 (1.2)	0.24 (1000)
10	Exterior Film ¹	-	-	R-0.2 (0.03 RSI)	-	-

¹ Value selected from table 1, p. 26.1 of 2009 ASHRAE Handbook – Fundamentals depending on surface orientation

Detail 5.1.115

Exterior Insulated 6" x 1 5/8" Steel Stud (16" o.c.) Wall Assembly with SOPREMA SOPRA-XPS 20 and ACS-S Thermal Clip Supporting Metal Cladding - Clear Wall

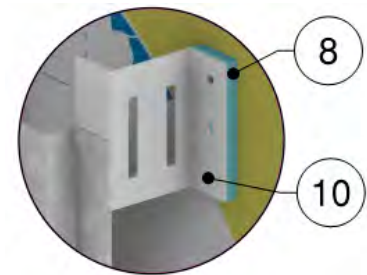
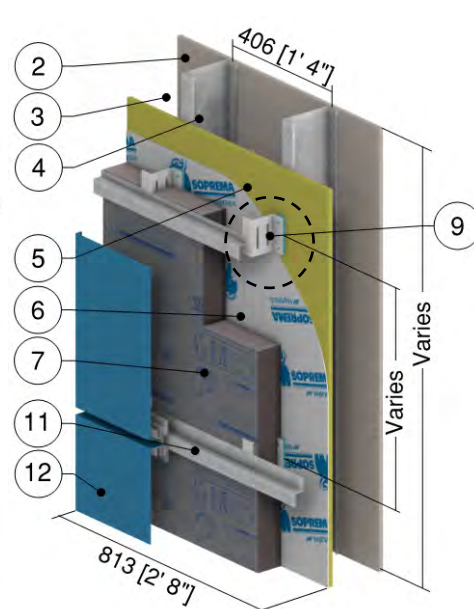
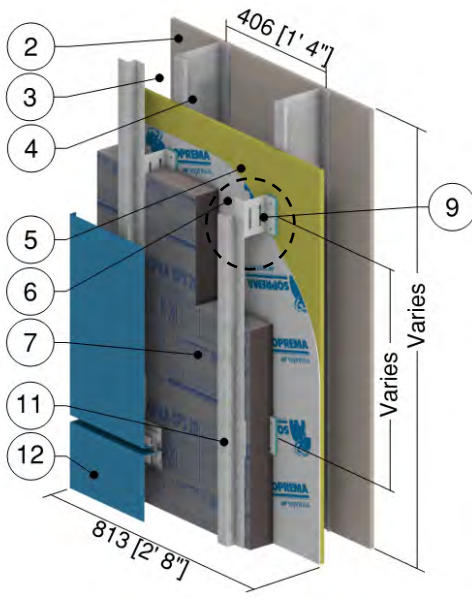

Vertical Girt: ACS Clip Detail

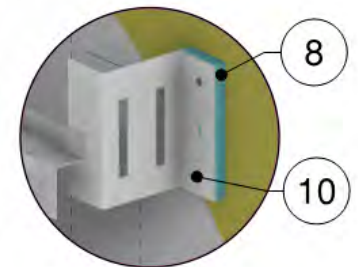

Horizontal Girt: ACS Clip Detail

ID	Component	Thickness Inches (mm)	Conductivity Btu-in / ft ² ·hr·°F (W/m K)	Nominal Resistance hr·ft ² ·°F/Btu (m ² K/W)	Density lb/ft ³ (kg/m ³)	Specific Heat Btu/lb·°F (J/kg K)
1	Interior Film ¹	-	-	R-0.7 (0.12 RSI)	-	-
2	Gypsum Board	1/2" (13)	1.1 (0.16)	R-0.5 (0.09 RSI)	50 (800)	0.26 (1090)
3	Air in Stud Cavity	6" (152)	-	R-0.9 (0.16 RSI)	0.075 (1.2)	0.24 (1000)
4	6" x 1 5/8" Steel Studs	18 Gauge	430 (62)	-	489 (7830)	0.12 (500)
5	Exterior Sheathing	1/2" (13)	1.1 (0.16)	R-0.5 (0.09 RSI)	50 (800)	0.26 (1090)
6	SOPREMA SOPRASEAL STICK 1100T membrane installed with SOPRASEAL STICK PRIMER	-	-	-	-	-
7	SOPRA-XPS 20 Exterior Insulation	Varies	0.20 (0.029)	R-15.0 to R-35.0 (2.64 RSI to 6.16 RSI)	2.5 (40)	0.29 (1220)
8	Thermal Break	1/2" (13)	0.13 (0.019)	-	2.1 (33)	0.50 (2100)
9	ACS-S Thermal Clip	16 Gauge	118 (17)	-	500 (8000)	0.13 (530)
10	Fastener	1/4" (6.4) Ø	347 (50)	-	489 (7830)	0.12 (500)
11	Girt	18 Gauge	430 (62)	-	489 (7830)	0.12 (500)
12	Cladding with 1/2" vented airspace incorporated into exterior heat transfer coefficient					
13	Exterior Film ¹	-	-	R-0.7 (0.12 RSI)	-	-

¹ Value selected from table 1, p. 26.1 of 2009 ASHRAE Handbook – Fundamentals depending on surface orientation

Detail 5.1.116

Exterior Insulated 6" x 1 5/8" Steel Stud (24" o.c.) Wall Assembly with SOPREMA SOPRA-XPS 20 and ACS-S Thermal Clip Supporting Metal Cladding - Clear Wall

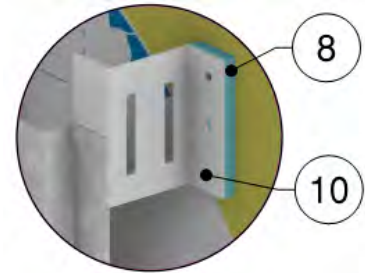
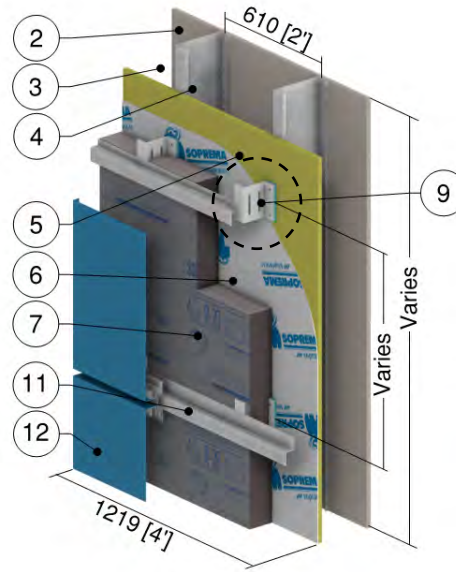
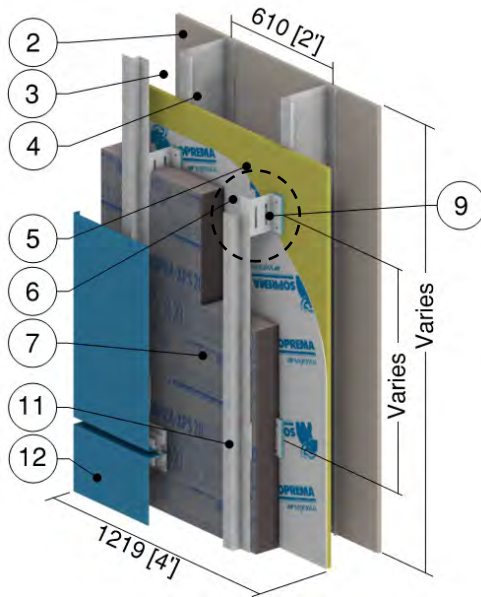

Vertical Girt: ACS Clip Detail

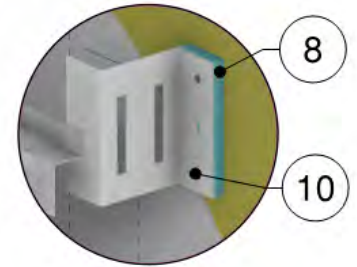

Horizontal Girt: ACS Clip Detail

ID	Component	Thickness Inches (mm)	Conductivity Btu·in / ft ² ·hr·°F (W/m K)	Nominal Resistance hr·ft ² ·°F/Btu (m ² K/W)	Density lb/ft ³ (kg/m ³)	Specific Heat Btu/lb·°F (J/kg K)
1	Interior Film ¹	-	-	R-0.7 (0.12 RSI)	-	-
2	Gypsum Board	1/2" (13)	1.1 (0.16)	R-0.5 (0.09 RSI)	50 (800)	0.26 (1090)
3	Air in Stud Cavity	6" (152)	-	R-0.9 (0.16 RSI)	0.075 (1.2)	0.24 (1000)
4	6" x 1 5/8" Steel Studs	18 Gauge	430 (62)	-	489 (7830)	0.12 (500)
5	Exterior Sheathing	1/2" (13)	1.1 (0.16)	R-0.5 (0.09 RSI)	50 (800)	0.26 (1090)
6	SOPREMA SOPRASEAL STICK 1100T membrane installed with SOPRASEAL STICK PRIMER	-	-	-	-	-
7	SOPRA-XPS 20 Exterior Insulation	Varies	0.20 (0.029)	R-15.0 to R-35.0 (2.64 RSI to 6.16 RSI)	2.5 (40)	0.29 (1220)
8	Thermal Break	1/2" (13)	0.13 (0.019)	-	2.1 (33)	0.50 (2100)
9	ACS-S Thermal Clip	16 Gauge	118 (17)	-	500 (8000)	0.13 (530)
10	Fastener	1/4" (6.4) Ø	347 (50)	-	489 (7830)	0.12 (500)
11	Girt	18 Gauge	430 (62)	-	489 (7830)	0.12 (500)
12	Cladding with 1/2" vented airspace incorporated into exterior heat transfer coefficient					
13	Exterior Film ¹	-	-	R-0.7 (0.12 RSI)	-	-

¹ Value selected from table 1, p. 26.1 of 2009 ASHRAE Handbook – Fundamentals depending on surface orientation

Detail 5.1.117

Exterior Insulated 6" x 1 5/8" Steel Stud (16" o.c.) Wall Assembly with SOPREMA SOPRA-SPF 202 and ACS-S Thermal Clip Supporting Metal Cladding - Clear Wall

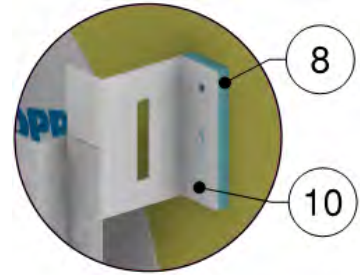
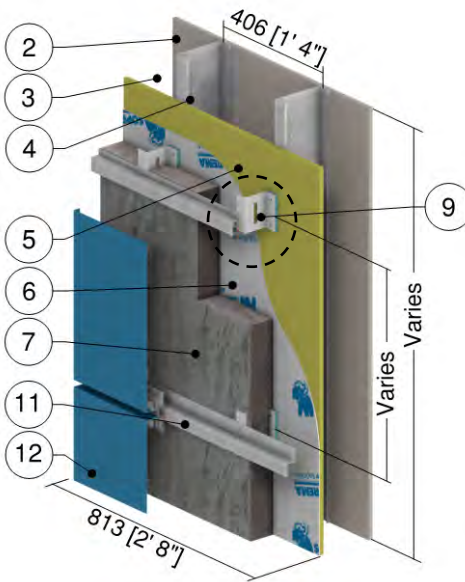
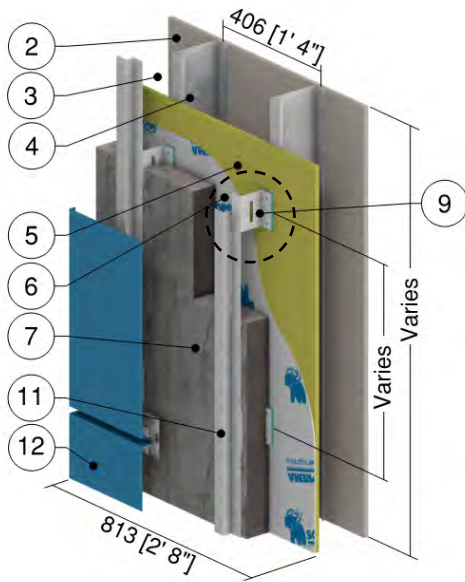

Vertical Girt: ACS Clip Detail

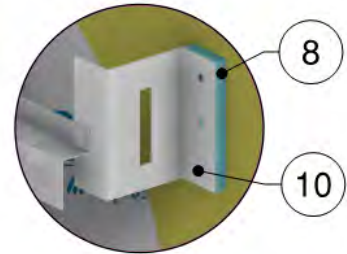

Horizontal Girt: ACS Clip Detail

ID	Component	Thickness Inches (mm)	Conductivity Btu-in / ft ² ·hr·°F (W/m K)	Nominal Resistance hr·ft ² ·°F/Btu (m ² K/W)	Density lb/ft ³ (kg/m ³)	Specific Heat Btu/lb·°F (J/kg K)
1	Interior Film ¹	-	-	R-0.7 (0.12 RSI)	-	-
2	Gypsum Board	1/2" (13)	1.1 (0.16)	R-0.5 (0.09 RSI)	50 (800)	0.26 (1090)
3	Air in Stud Cavity	6" (152)	-	R-0.9 (0.16 RSI)	0.075 (1.2)	0.24 (1000)
4	6" x 1 5/8" Steel Studs	18 Gauge	430 (62)	-	489 (7830)	0.12 (500)
5	Exterior Sheathing	1/2" (13)	1.1 (0.16)	R-0.5 (0.09 RSI)	50 (800)	0.26 (1090)
6	SOPREMA SOPRASEAL STICK 1100T membrane installed with SOPRASEAL STICK PRIMER	-	-	-	-	-
7	SOPRA-SPF 202 Exterior Insulation	Varies	0.16 (0.023)	R-6.2 to R-37.2 (1.09 RSI to 6.55 RSI)	1.8 (28)	0.29 (1220)
8	Thermal Break	1/2" (13)	0.13 (0.019)	-	2.1 (33)	0.50 (2100)
9	ACS-S Thermal Clip	16 Gauge	118 (17)	-	500 (8000)	0.13 (530)
10	Fastener	1/4" (6.4) Ø	347 (50)	-	489 (7830)	0.12 (500)
11	Girt	18 Gauge	430 (62)	-	489 (7830)	0.12 (500)
12	Cladding with 1/2" vented airspace incorporated into exterior heat transfer coefficient					
13	Exterior Film ¹	-	-	R-0.7 (0.12 RSI)	-	-

¹ Value selected from table 1, p. 26.1 of 2009 ASHRAE Handbook – Fundamentals depending on surface orientation

Detail 5.1.118

Exterior Insulated 6" x 1 5/8" Steel Stud (24" o.c.) Wall Assembly with SOPREMA SOPRA-SPF 202 and ACS-S Thermal Clip Supporting Metal Cladding - Clear Wall

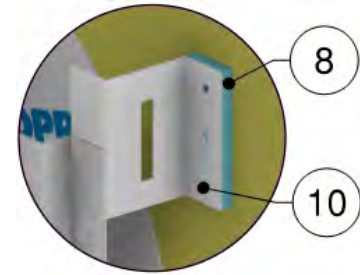
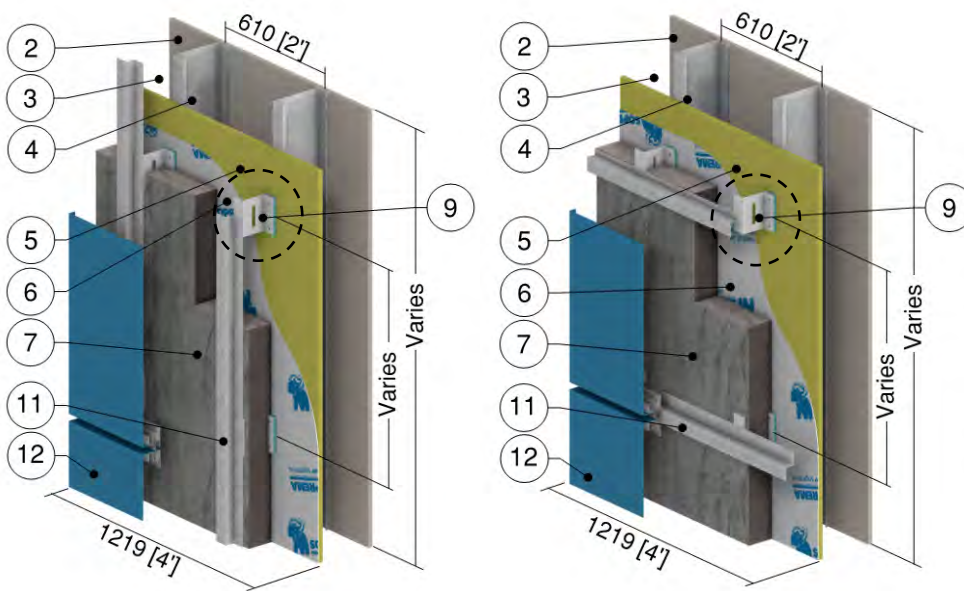

Vertical Girt: ACS Clip Detail

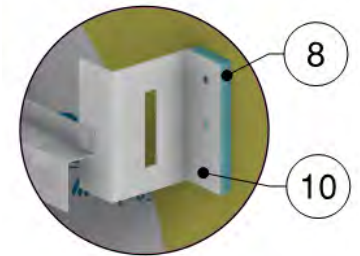

Horizontal Girt: ACS Clip Detail

ID	Component	Thickness Inches (mm)	Conductivity Btu-in / ft ² ·hr·°F (W/m K)	Nominal Resistance hr·ft ² ·°F/Btu (m ² K/W)	Density lb/ft ³ (kg/m ³)	Specific Heat Btu/lb·°F (J/kg K)
1	Interior Film ¹	-	-	R-0.7 (0.12 RSI)	-	-
2	Gypsum Board	1/2" (13)	1.1 (0.16)	R-0.5 (0.09 RSI)	50 (800)	0.26 (1090)
3	Air in Stud Cavity	6" (152)	-	R-0.9 (0.16 RSI)	0.075 (1.2)	0.24 (1000)
4	6" x 1 5/8" Steel Studs	18 Gauge	430 (62)	-	489 (7830)	0.12 (500)
5	Exterior Sheathing	1/2" (13)	1.1 (0.16)	R-0.5 (0.09 RSI)	50 (800)	0.26 (1090)
6	SOPREMA SOPRASEAL STICK 1100T membrane installed with SOPRASEAL STICK PRIMER	-	-	-	-	-
7	SOPRA-SPF 202 Exterior Insulation	Varies	0.16 (0.023)	R-6.2 to R-37.2 (1.09 RSI to 6.55 RSI)	1.8 (28)	0.29 (1220)
8	Thermal Break	1/2" (13)	0.13 (0.019)	-	2.1 (33)	0.50 (2100)
9	ACS-S Thermal Clip	16 Gauge	118 (17)	-	500 (8000)	0.13 (530)
10	Fastener	1/4" (6.4) Ø	347 (50)	-	489 (7830)	0.12 (500)
11	Girt	18 Gauge	430 (62)	-	489 (7830)	0.12 (500)
12	Cladding with 1/2" vented airspace incorporated into exterior heat transfer coefficient					
13	Exterior Film ¹	-	-	R-0.7 (0.12 RSI)	-	-

¹ Value selected from table 1, p. 26.1 of 2009 ASHRAE Handbook – Fundamentals depending on surface orientation

Detail 5.1.119

Exterior Insulated 6" x 1 5/8" Steel Stud (16" o.c.) Wall Assembly with SOPREMA SOPRA-ISO V ALU and ACS-S Thermal Clip Supporting Metal Cladding - Clear Wall

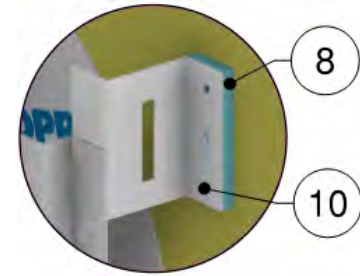
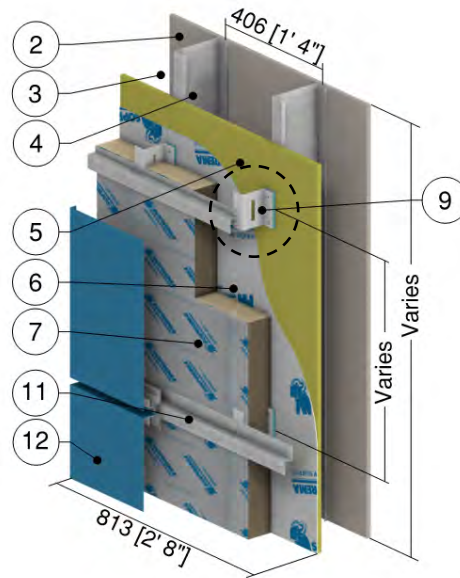
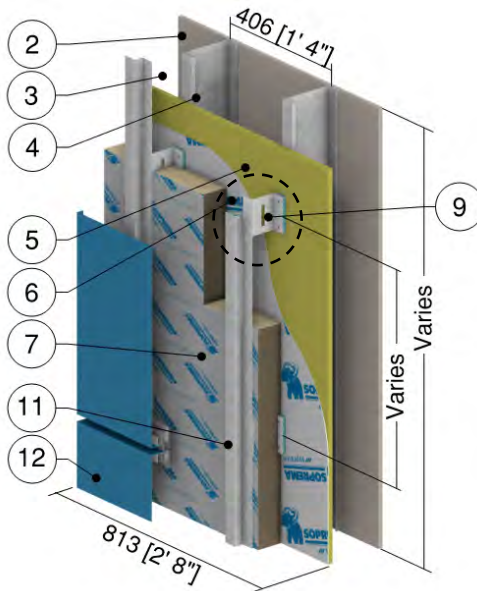

Vertical Girt: ACS Clip Detail

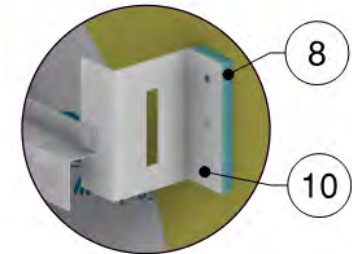

Horizontal Girt: ACS Clip Detail

ID	Component	Thickness Inches (mm)	Conductivity Btu-in / ft ² ·hr·°F (W/m K)	Nominal Resistance hr·ft ² ·°F/Btu (m ² K/W)	Density lb/ft ³ (kg/m ³)	Specific Heat Btu/lb·°F (J/kg K)
1	Interior Film ¹	-	-	R-0.7 (0.12 RSI)	-	-
2	Gypsum Board	1/2" (13)	1.1 (0.16)	R-0.5 (0.09 RSI)	50 (800)	0.26 (1090)
3	Air in Stud Cavity	6" (152)	-	R-0.9 (0.16 RSI)	0.075 (1.2)	0.24 (1000)
4	6" x 1 5/8" Steel Studs	18 Gauge	430 (62)	-	489 (7830)	0.12 (500)
5	Exterior Sheathing	1/2" (13)	1.1 (0.16)	R-0.5 (0.09 RSI)	50 (800)	0.26 (1090)
6	SOPREMA SOPRASEAL STICK 1100T membrane installed with SOPRASEAL STICK PRIMER	-	-	-	-	-
7	SOPRA-ISO V ALU Exterior Insulation	Varies	0.15 (0.022)	R-6.5 to R-39.0 (1.14 RSI to 6.87 RSI)	1.9 (30)	0.36 (1500)
8	Thermal Break	1/2" (13)	0.13 (0.019)	-	2.1 (33)	0.50 (2100)
9	ACS-S Thermal Clip	16 Gauge	118 (17)	-	500 (8000)	0.13 (530)
10	Fastener	1/4" (6.4) Ø	347 (50)	-	489 (7830)	0.12 (500)
11	Girt	18 Gauge	430 (62)	-	489 (7830)	0.12 (500)
12	Cladding with 1/2" vented airspace incorporated into exterior heat transfer coefficient					
13	Exterior Film ¹	-	-	R-0.7 (0.12 RSI)	-	-

¹ Value selected from table 1, p. 26.1 of 2009 ASHRAE Handbook – Fundamentals depending on surface orientation

Detail 5.1.120

Exterior Insulated 6" x 1 5/8" Steel Stud (24" o.c.) Wall Assembly with SOPREMA SOPRA-ISO V ALU and ACS-S Thermal Clip Supporting Metal Cladding - Clear Wall

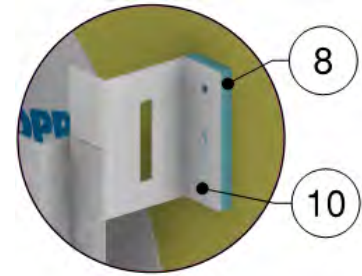
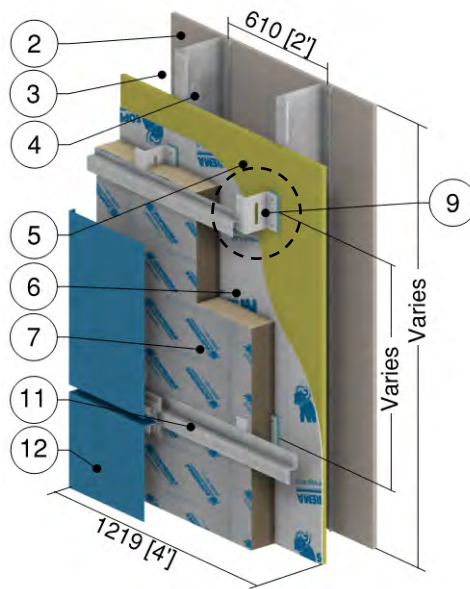
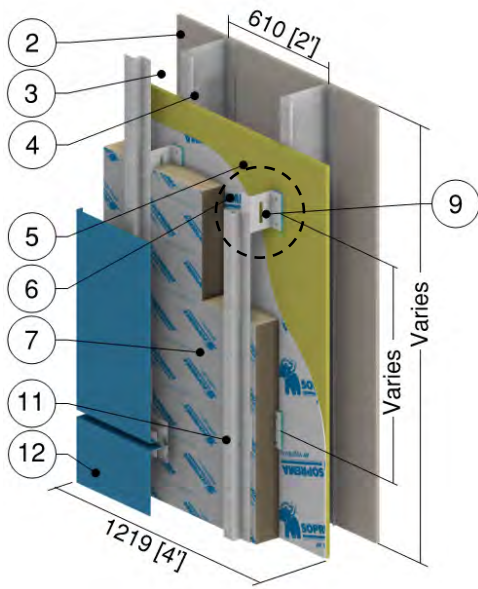

Vertical Girt: ACS Clip Detail

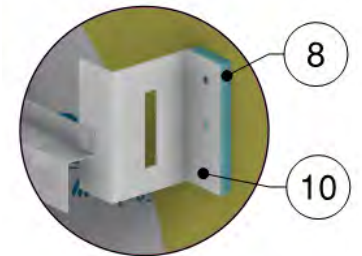

Horizontal Girt: ACS Clip Detail

ID	Component	Thickness Inches (mm)	Conductivity Btu-in / ft ² -hr-°F (W/m K)	Nominal Resistance hr-ft ² -°F/Btu (m ² K/W)	Density lb/ft ³ (kg/m ³)	Specific Heat Btu/lb-°F (J/kg K)
1	Interior Film ¹	-	-	R-0.7 (0.12 RSI)	-	-
2	Gypsum Board	1/2" (13)	1.1 (0.16)	R-0.5 (0.09 RSI)	50 (800)	0.26 (1090)
3	Air in Stud Cavity	6" (152)	-	R-0.9 (0.16 RSI)	0.075 (1.2)	0.24 (1000)
4	6" x 1 5/8" Steel Studs	18 Gauge	430 (62)	-	489 (7830)	0.12 (500)
5	Exterior Sheathing	1/2" (13)	1.1 (0.16)	R-0.5 (0.09 RSI)	50 (800)	0.26 (1090)
6	SOPREMA SOPRASEAL STICK 1100T membrane installed with SOPRASEAL STICK PRIMER	-	-	-	-	-
7	SOPRA-ISO V ALU Exterior Insulation	Varies	0.15 (0.022)	R-6.5 to R-39.0 (1.14 RSI to 6.87 RSI)	1.9 (30)	0.36 (1500)
8	Thermal Break	1/2" (13)	0.13 (0.019)	-	2.1 (33)	0.50 (2100)
9	ACS-S Thermal Clip	16 Gauge	118 (17)	-	500 (8000)	0.13 (530)
10	Fastener	1/4" (6.4) Ø	347 (50)	-	489 (7830)	0.12 (500)
11	Girt	18 Gauge	430 (62)	-	489 (7830)	0.12 (500)
12	Cladding with 1/2" vented airspace incorporated into exterior heat transfer coefficient					
13	Exterior Film ¹	-	-	R-0.7 (0.12 RSI)	-	-

¹ Value selected from table 1, p. 26.1 of 2009 ASHRAE Handbook – Fundamentals depending on surface orientation

Detail 5.1.121

Exterior Insulated 6" x 1 5/8" Steel Stud (16" o.c.) Wall Assembly with Mineral Wool and ACS-S Thermal Clip Supporting Metal Cladding - Clear Wall

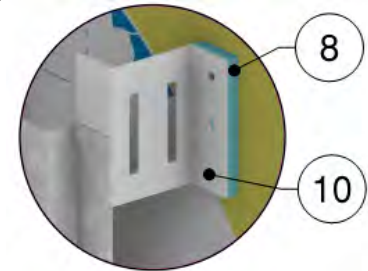
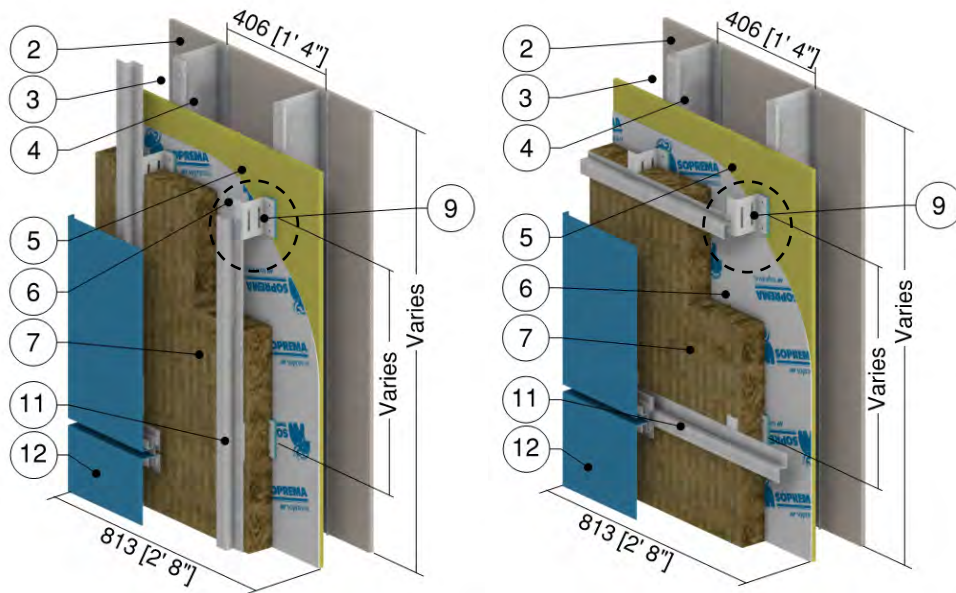

Vertical Girt: ACS Clip Detail

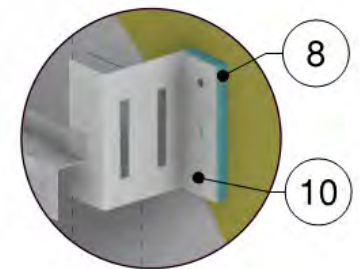

Horizontal Girt: ACS Clip Detail

ID	Component	Thickness Inches (mm)	Conductivity Btu-in / ft ² ·hr·°F (W/m K)	Nominal Resistance hr·ft ² ·°F/Btu (m ² K/W)	Density lb/ft ³ (kg/m ³)	Specific Heat Btu/lb·°F (J/kg K)
1	Interior Film ¹	-	-	R-0.7 (0.12 RSI)	-	-
2	Gypsum Board	1/2" (13)	1.1 (0.16)	R-0.5 (0.09 RSI)	50 (800)	0.26 (1090)
3	Air in Stud Cavity	6" (152)	-	R-0.9 (0.16 RSI)	0.075 (1.2)	0.24 (1000)
4	6" x 1 5/8" Steel Studs	18 Gauge	430 (62)	-	489 (7830)	0.12 (500)
5	Exterior Sheathing	1/2" (13)	1.1 (0.16)	R-0.5 (0.09 RSI)	50 (800)	0.26 (1090)
6	SOPREMA SOPRASEAL STICK 1100T membrane installed with SOPRASEAL STICK PRIMER	-	-	-	-	-
7	Exterior Mineral Wool Insulation	Varies	0.23 (0.034)	R-12.9 to R-34.4 (2.27 RSI to 6.06 RSI)	1.8 (28)	0.29 (1220)
8	Thermal Break	1/2" (13)	0.13 (0.019)	-	2.1 (33)	0.50 (2100)
9	ACS-S Thermal Clip	16 Gauge	118 (17)	-	500 (8000)	0.13 (530)
10	Fastener	1/4" (6.4) Ø	347 (50)	-	489 (7830)	0.12 (500)
11	Girt	18 Gauge	430 (62)	-	489 (7830)	0.12 (500)
Cladding with 1/2" vented airspace incorporated into exterior heat transfer coefficient						
12	Exterior Film ¹	-	-	R-0.7 (0.12 RSI)	-	-

¹ Value selected from table 1, p. 26.1 of 2009 ASHRAE Handbook – Fundamentals depending on surface orientation

Detail 5.1.122

Exterior Insulated 6" x 1 5/8" Steel Stud (24" o.c.) Wall Assembly with Mineral Wool and ACS-S Thermal Clip Supporting Metal Cladding - Clear Wall

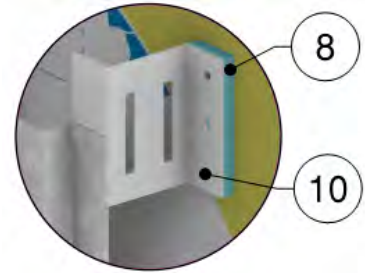
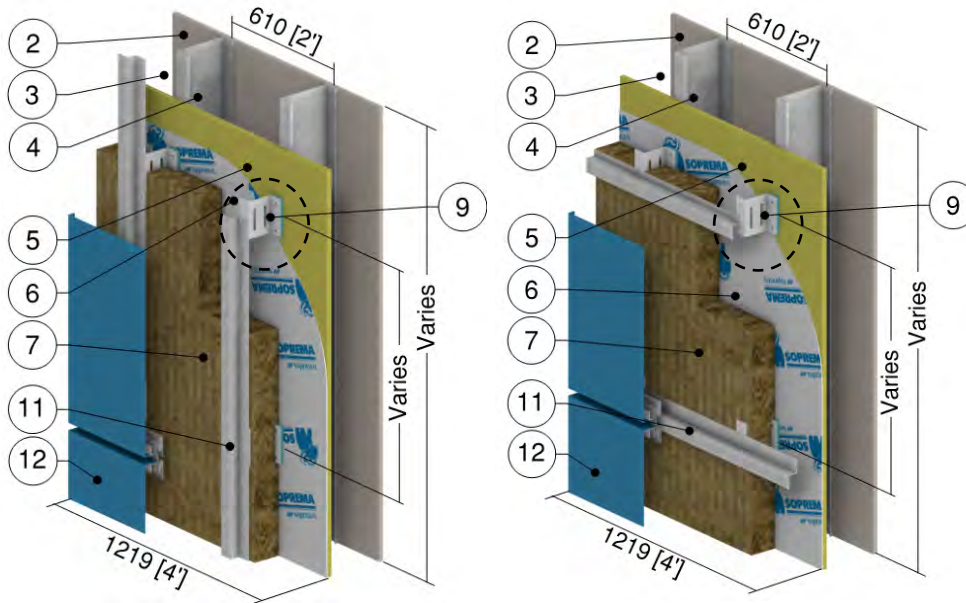

Vertical Girt: ACS Clip Detail

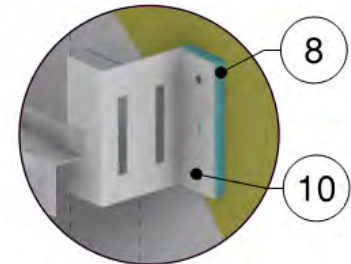

Horizontal Girt: ACS Clip Detail

ID	Component	Thickness Inches (mm)	Conductivity Btu-in / ft ² ·hr·°F (W/m K)	Nominal Resistance hr·ft ² ·°F/Btu (m ² K/W)	Density lb/ft ³ (kg/m ³)	Specific Heat Btu/lb·°F (J/kg K)
1	Interior Film ¹	-	-	R-0.7 (0.12 RSI)	-	-
2	Gypsum Board	1/2" (13)	1.1 (0.16)	R-0.5 (0.09 RSI)	50 (800)	0.26 (1090)
3	Air in Stud Cavity	6" (152)	-	R-0.9 (0.16 RSI)	0.075 (1.2)	0.24 (1000)
4	6" x 1 5/8" Steel Studs	18 Gauge	430 (62)	-	489 (7830)	0.12 (500)
5	Exterior Sheathing	1/2" (13)	1.1 (0.16)	R-0.5 (0.09 RSI)	50 (800)	0.26 (1090)
6	SOPREMA SOPRASEAL STICK 1100T membrane installed with SOPRASEAL STICK PRIMER	-	-	-	-	-
7	Exterior Mineral Wool Insulation	Varies	0.23 (0.034)	R-12.9 to R-34.4 (2.27 RSI to 6.06 RSI)	1.8 (28)	0.29 (1220)
8	Thermal Break	1/2" (13)	0.13 (0.019)	-	2.1 (33)	0.50 (2100)
9	ACS-S Thermal Clip	16 Gauge	118 (17)	-	500 (8000)	0.13 (530)
10	Fastener	1/4" (6.4) Ø	347 (50)	-	489 (7830)	0.12 (500)
11	Girt	18 Gauge	430 (62)	-	489 (7830)	0.12 (500)
Cladding with 1/2" vented airspace incorporated into exterior heat transfer coefficient						
12						
13	Exterior Film ¹	-	-	R-0.7 (0.12 RSI)	-	-

¹ Value selected from table 1, p. 26.1 of 2009 ASHRAE Handbook – Fundamentals depending on surface orientation

Detail 5.1.123

Exterior and Interior Insulated 6" x 1 5/8" Steel Stud (16" o.c.) Wall Assembly with SOPREMA SOPRA-XPS 20 and ACS-S Thermal Clip Supporting Metal Cladding with R-20 Cellulose Insulation in Stud Cavity - Clear Wall

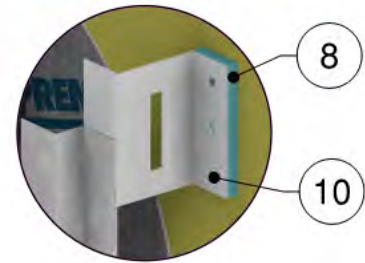
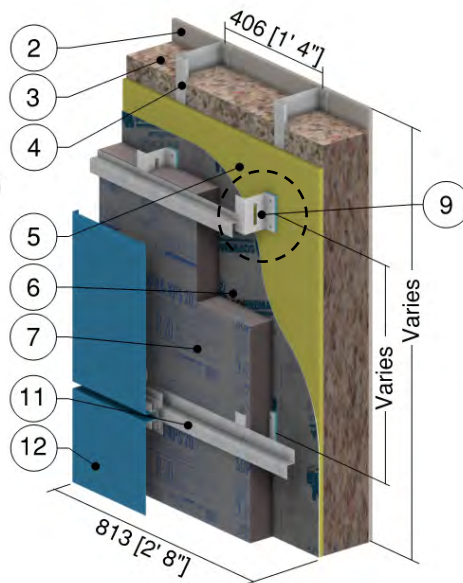
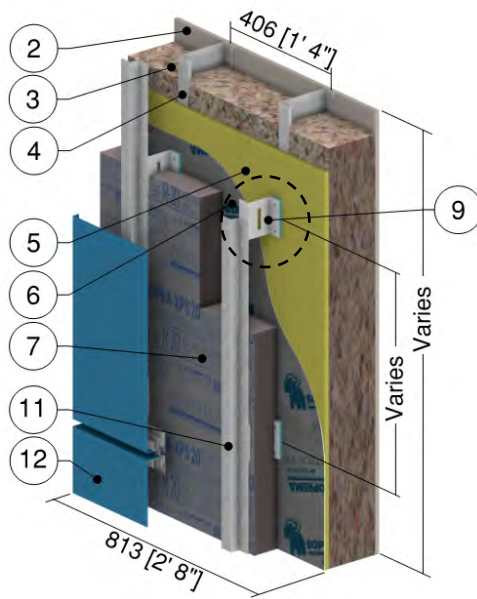

Vertical Girt: ACS Clip Detail

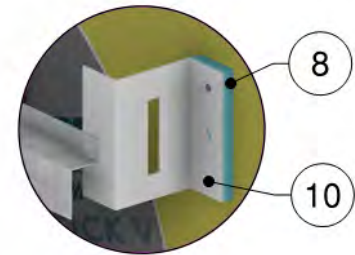

Horizontal Girt: ACS Clip Detail

ID	Component	Thickness Inches (mm)	Conductivity Btu-in / ft ² -hr-°F (W/m K)	Nominal Resistance hr-ft ² -°F/Btu (m ² K/W)	Density lb/ft ³ (kg/m ³)	Specific Heat Btu/lb-°F (J/kg K)
1	Interior Film ¹	-	-	R-0.7 (0.12 RSI)	-	-
2	Gypsum Board	1/2" (13)	1.1 (0.16)	R-0.5 (0.09 RSI)	50 (800)	0.26 (1090)
3	Cellulose Insulation in Stud Cavity	6" (152)	0.30 (0.043)	R-20.0 (3.52 RSI)	1.2 (19)	0.33 (1400)
4	6" x 1 5/8" Steel Studs	18 Gauge	430 (62)	-	489 (7830)	0.12 (500)
5	Exterior Sheathing	1/2" (13)	1.1 (0.16)	R-0.5 (0.09 RSI)	50 (800)	0.26 (1090)
6	SOPREMA SOPRASEAL STICK VP membrane	-	-	-	-	-
7	SOPRA-XPS 20 Exterior Insulation	Varies	0.20 (0.029)	R-5.0 to R-35.0 (0.88 RSI to 6.16 RSI)	2.5 (40)	0.29 (1220)
8	Thermal Break	1/2" (13)	0.13 (0.019)	-	2.1 (33)	0.50 (2100)
9	ACS-S Thermal Clip	16 Gauge	118 (17)	-	500 (8000)	0.13 (530)
10	Fastener	1/4" (6.4) Ø	347 (50)	-	489 (7830)	0.12 (500)
11	Girt	18 Gauge	430 (62)	-	489 (7830)	0.12 (500)
12	Cladding with 1/2" vented airspace incorporated into exterior heat transfer coefficient					
13	Exterior Film ¹	-	-	R-0.7 (0.12 RSI)	-	-

¹ Value selected from table 1, p. 26.1 of 2009 ASHRAE Handbook – Fundamentals depending on surface orientation

Detail 5.1.124

Exterior and Interior Insulated 6" x 1 5/8" Steel Stud (24" o.c.) Wall Assembly with SOPREMA SOPRA-XPS 20 and ACS-S Thermal Clip Supporting Metal Cladding with R-20 Cellulose Insulation in Stud Cavity - Clear Wall

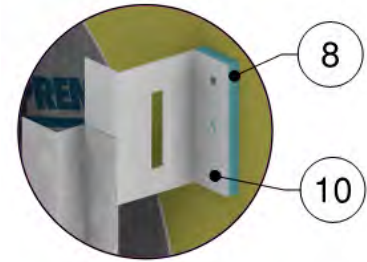
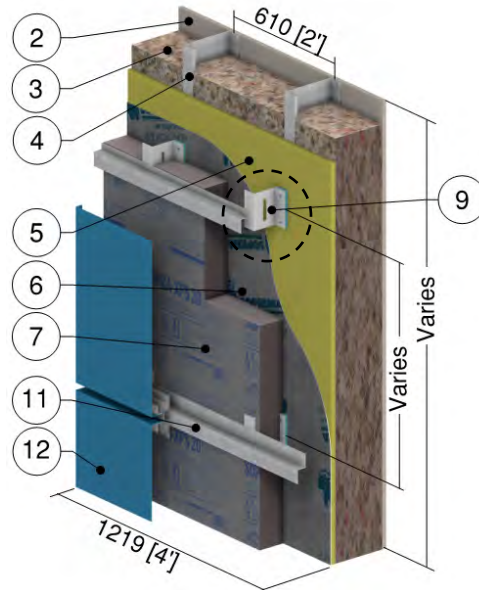
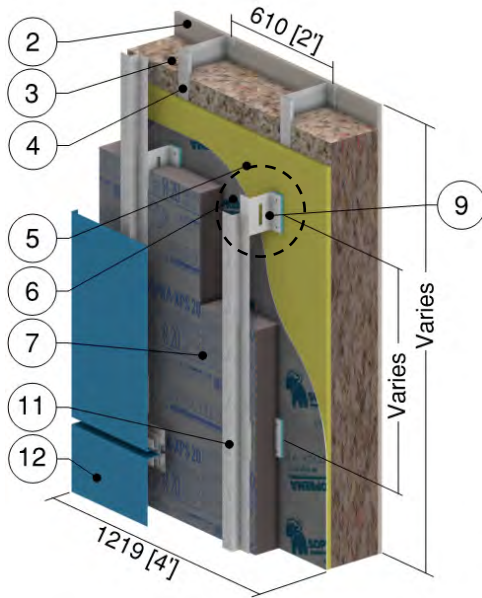

Vertical Girt: ACS Clip Detail

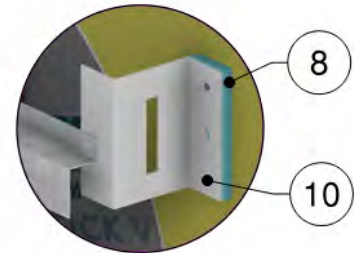

Horizontal Girt: ACS Clip Detail

ID	Component	Thickness Inches (mm)	Conductivity Btu-in / ft ² -hr-°F (W/m K)	Nominal Resistance hr-ft ² -°F/Btu (m ² K/W)	Density lb/ft ³ (kg/m ³)	Specific Heat Btu/lb-°F (J/kg K)
1	Interior Film ¹	-	-	R-0.7 (0.12 RSI)	-	-
2	Gypsum Board	1/2" (13)	1.1 (0.16)	R-0.5 (0.09 RSI)	50 (800)	0.26 (1090)
3	Cellulose Insulation in Stud Cavity	6" (152)	0.30 (0.043)	R-20.0 (3.52 RSI)	1.2 (19)	0.33 (1400)
4	6" x 1 5/8" Steel Studs	18 Gauge	430 (62)	-	489 (7830)	0.12 (500)
5	Exterior Sheathing	1/2" (13)	1.1 (0.16)	R-0.5 (0.09 RSI)	50 (800)	0.26 (1090)
6	SOPREMA SOPRASEAL STICK VP membrane	-	-	-	-	-
7	SOPRA-XPS 20 Exterior Insulation	Varies	0.20 (0.029)	R-5.0 to R-35.0 (0.88 RSI to 6.16 RSI)	2.5 (40)	0.29 (1220)
8	Thermal Break	1/2" (13)	0.13 (0.019)	-	2.1 (33)	0.50 (2100)
9	ACS-S Thermal Clip	16 Gauge	118 (17)	-	500 (8000)	0.13 (530)
10	Fastener	1/4" (6.4) Ø	347 (50)	-	489 (7830)	0.12 (500)
11	Girt	18 Gauge	430 (62)	-	489 (7830)	0.12 (500)
12	Cladding with 1/2" vented airspace incorporated into exterior heat transfer coefficient					
13	Exterior Film ¹	-	-	R-0.7 (0.12 RSI)	-	-

¹ Value selected from table 1, p. 26.1 of 2009 ASHRAE Handbook – Fundamentals depending on surface orientation

Detail 5.1.125

Exterior and Interior Insulated 6" x 1 5/8" Steel Stud (16" o.c.) Wall Assembly with SOPREMA SOPRA-SPF 202 and ACS-S Thermal Clip Supporting Metal Cladding with R-20 Cellulose Insulation in Stud Cavity - Clear Wall

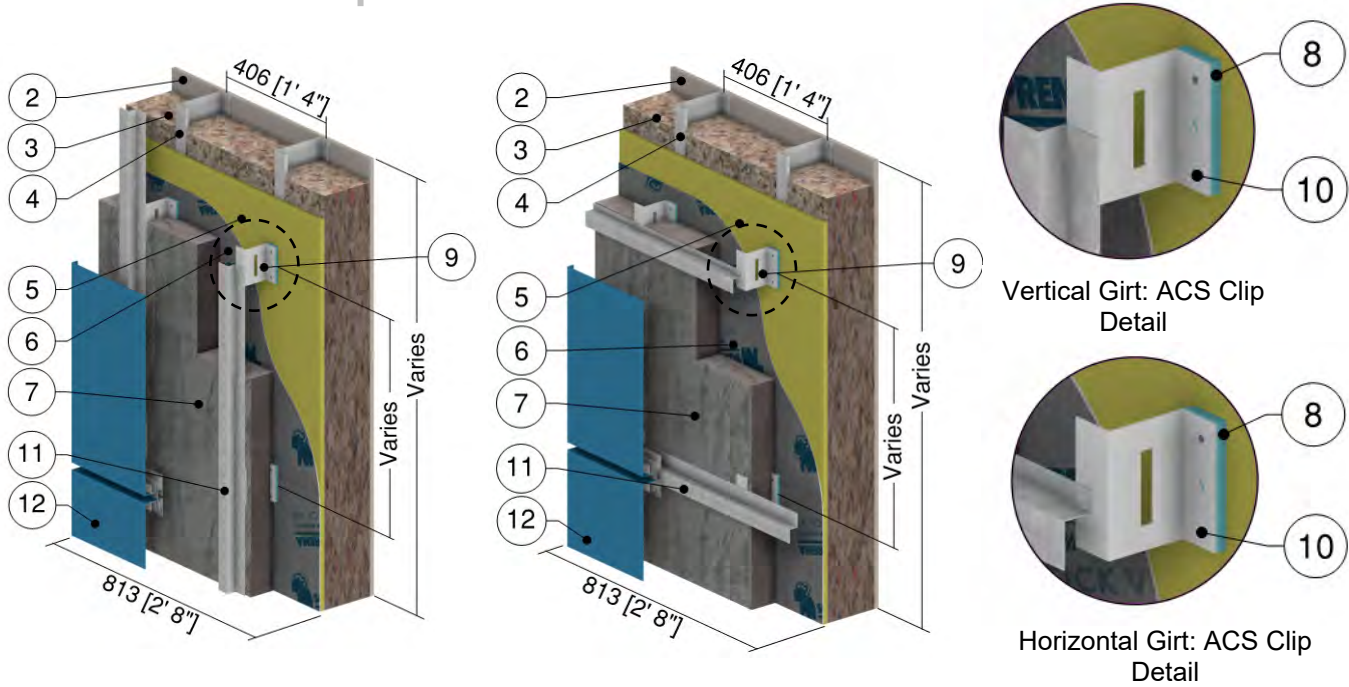

ID	Component	Thickness Inches (mm)	Conductivity Btu-in / ft ² -hr-°F (W/m K)	Nominal Resistance hr-ft ² -°F/Btu (m ² K/W)	Density lb/ft ³ (kg/m ³)	Specific Heat Btu/lb-°F (J/kg K)
1	Interior Film ¹	-	-	R-0.7 (0.12 RSI)	-	-
2	Gypsum Board	1/2" (13)	1.1 (0.16)	R-0.5 (0.09 RSI)	50 (800)	0.26 (1090)
3	Cellulose Insulation in Stud Cavity	6" (152)	0.30 (0.043)	R-20.0 (3.52 RSI)	1.2 (19)	0.33 (1400)
4	6" x 1 5/8" Steel Studs	18 Gauge	430 (62)	-	489 (7830)	0.12 (500)
5	Exterior Sheathing	1/2" (13)	1.1 (0.16)	R-0.5 (0.09 RSI)	50 (800)	0.26 (1090)
6	SOPREMA SOPRASEAL STICK VP membrane	-	-	-	-	-
7	SOPRA-SPF 202 Exterior Insulation	Varies	0.16 (0.023)	R-6.2 to R-43.4 (1.09 RSI to 7.64 RSI)	1.8 (28)	0.29 (1220)
8	Thermal Break	1/2" (13)	0.13 (0.019)	-	2.1 (33)	0.50 (2100)
9	ACS-S Thermal Clip	16 Gauge	118 (17)	-	500 (8000)	0.13 (530)
10	Fastener	1/4" (6.4) Ø	347 (50)	-	489 (7830)	0.12 (500)
11	Girt	18 Gauge	430 (62)	-	489 (7830)	0.12 (500)
12	Cladding with 1/2" vented airspace incorporated into exterior heat transfer coefficient					
13	Exterior Film ¹	-	-	R-0.7 (0.12 RSI)	-	-

¹ Value selected from table 1, p. 26.1 of 2009 ASHRAE Handbook – Fundamentals depending on surface orientation

Detail 5.1.126

Exterior and Interior Insulated 6" x 1 5/8" Steel Stud (24" o.c.) Wall Assembly with SOPREMA SOPRA-SPF 202 and ACS-S Thermal Clip Supporting Metal Cladding with R-20 Cellulose Insulation in Stud Cavity - Clear Wall

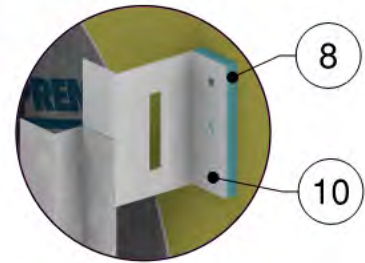
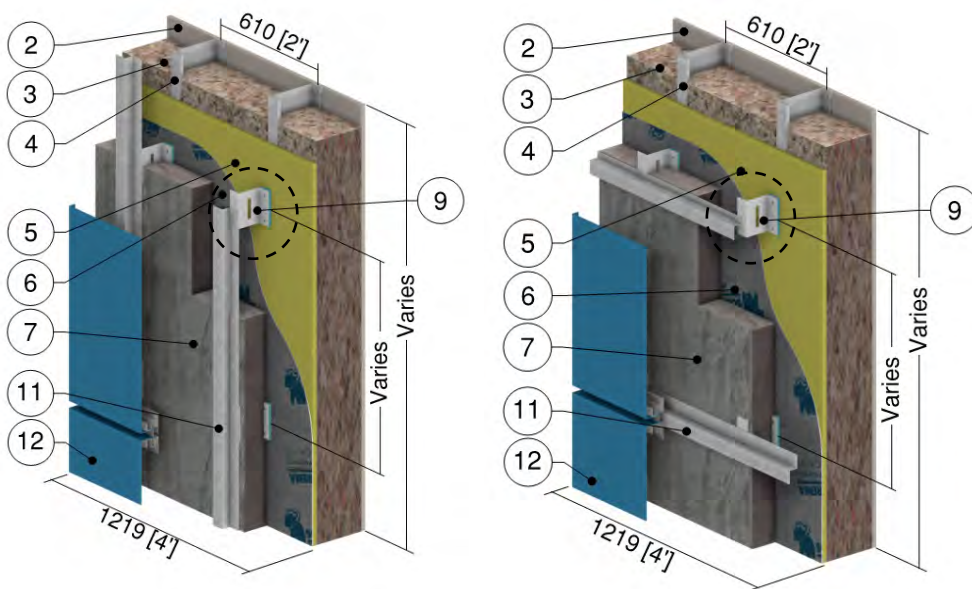

Vertical Girt: ACS Clip Detail

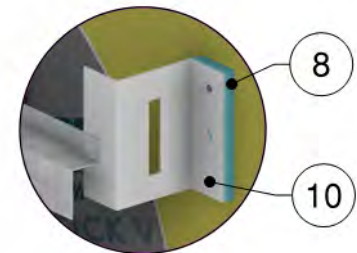

Horizontal Girt: ACS Clip Detail

ID	Component	Thickness Inches (mm)	Conductivity Btu-in / ft ² ·hr·°F (W/m K)	Nominal Resistance hr·ft ² ·°F/Btu (m ² K/W)	Density lb/ft ³ (kg/m ³)	Specific Heat Btu/lb·°F (J/kg K)
1	Interior Film ¹	-	-	R-0.7 (0.12 RSI)	-	-
2	Gypsum Board	1/2" (13)	1.1 (0.16)	R-0.5 (0.09 RSI)	50 (800)	0.26 (1090)
3	Cellulose Insulation in Stud Cavity	6" (152)	0.30 (0.043)	R-20.0 (3.52 RSI)	1.2 (19)	0.33 (1400)
4	6" x 1 5/8" Steel Studs	18 Gauge	430 (62)	-	489 (7830)	0.12 (500)
5	Exterior Sheathing	1/2" (13)	1.1 (0.16)	R-0.5 (0.09 RSI)	50 (800)	0.26 (1090)
6	SOPREMA SOPRASEAL STICK VP membrane	-	-	-	-	-
7	SOPRA-SPF 202 Exterior Insulation	Varies	0.16 (0.023)	R-6.2 to R-43.4 (1.09 RSI to 7.64 RSI)	1.8 (28)	0.29 (1220)
8	Thermal Break	1/2" (13)	0.13 (0.019)	-	2.1 (33)	0.50 (2100)
9	ACS-S Thermal Clip	16 Gauge	118 (17)	-	500 (8000)	0.13 (530)
10	Fastener	1/4" (6.4) Ø	347 (50)	-	489 (7830)	0.12 (500)
11	Girt	18 Gauge	430 (62)	-	489 (7830)	0.12 (500)
12	Cladding with 1/2" vented airspace incorporated into exterior heat transfer coefficient					
13	Exterior Film ¹	-	-	R-0.7 (0.12 RSI)	-	-

¹ Value selected from table 1, p. 26.1 of 2009 ASHRAE Handbook – Fundamentals depending on surface orientation

Detail 5.1.127

Exterior and Interior Insulated 6" x 1 5/8" Steel Stud (16" o.c.) Wall Assembly with SOPREMA SOPRA-ISO V PLUS and ACS-S Thermal Clip Supporting Metal Cladding with R-20 Cellulose Insulation in Stud Cavity - Clear Wall

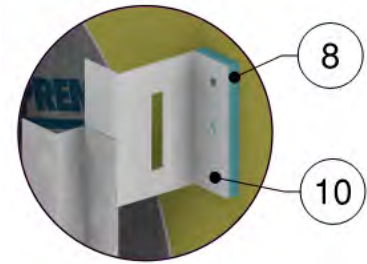
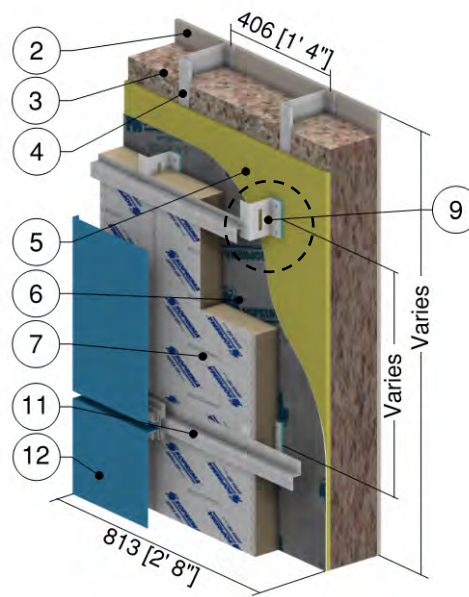
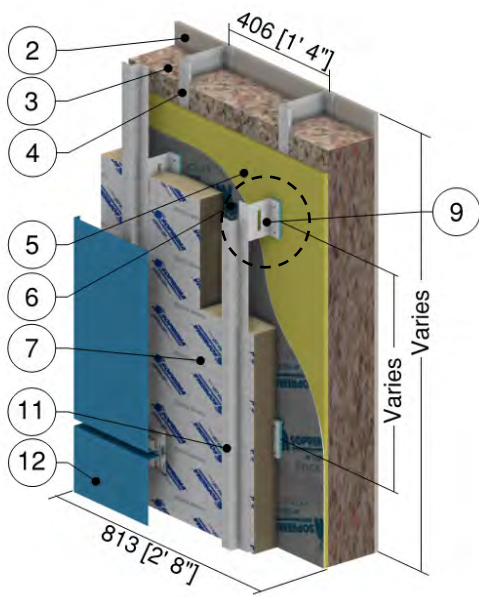

Vertical Girt: ACS Clip Detail

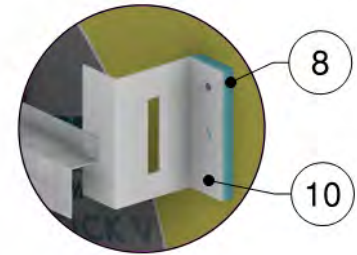

Horizontal Girt: ACS Clip Detail

ID	Component	Thickness Inches (mm)	Conductivity Btu-in / ft ² -hr-°F (W/m K)	Nominal Resistance hr-ft ² -°F/Btu (m ² K/W)	Density lb/ft ³ (kg/m ³)	Specific Heat Btu/lb-°F (J/kg K)
1	Interior Film ¹	-	-	R-0.7 (0.12 RSI)	-	-
2	Gypsum Board	1/2" (13)	1.1 (0.16)	R-0.5 (0.09 RSI)	50 (800)	0.26 (1090)
3	Cellulose Insulation in Stud Cavity	6" (152)	0.30 (0.043)	R-20.0 (3.52 RSI)	1.2 (19)	0.33 (1400)
4	6" x 1 5/8" Steel Studs	18 Gauge	430 (62)	-	489 (7830)	0.12 (500)
5	Exterior Sheathing	1/2" (13)	1.1 (0.16)	R-0.5 (0.09 RSI)	50 (800)	0.26 (1090)
6	SOPREMA SOPRASEAL STICK VP membrane	-	-	-	-	-
7	SOPRA-ISO V PLUS Exterior Insulation	Varies	0.17 (0.024)	R-6.0 to R-42.0 (1.06 RSI to 7.40 RSI)	1.9 (30)	0.36 (1500)
8	Thermal Break	1/2" (13)	0.13 (0.019)	-	2.1 (33)	0.50 (2100)
9	ACS-S Thermal Clip	16 Gauge	118 (17)	-	500 (8000)	0.13 (530)
10	Fastener	1/4" (6.4) Ø	347 (50)	-	489 (7830)	0.12 (500)
11	Girt	18 Gauge	430 (62)	-	489 (7830)	0.12 (500)
12	Cladding with 1/2" vented airspace incorporated into exterior heat transfer coefficient					
13	Exterior Film ¹	-	-	R-0.7 (0.12 RSI)	-	-

¹ Value selected from table 1, p. 26.1 of 2009 ASHRAE Handbook – Fundamentals depending on surface orientation

Detail 5.1.128

Exterior and Interior Insulated 6" x 1 5/8" Steel Stud (24" o.c.) Wall Assembly with SOPREMA SOPRA-ISO V PLUS and ACS-S Thermal Clip Supporting Metal Cladding with R-20 Cellulose Insulation in Stud Cavity - Clear Wall

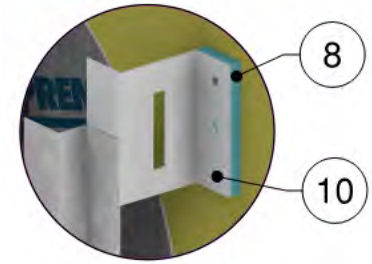
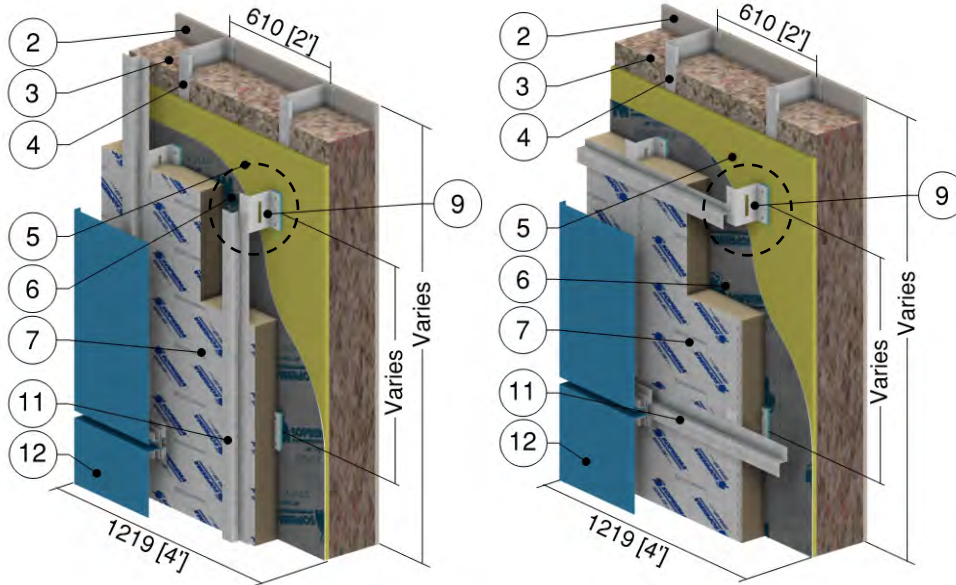

Vertical Girt: ACS Clip Detail

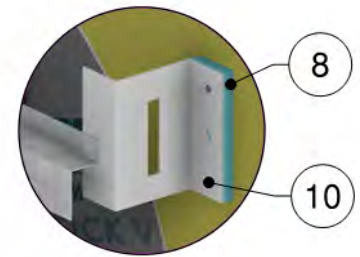

Horizontal Girt: ACS Clip Detail

ID	Component	Thickness Inches (mm)	Conductivity Btu-in / ft ² ·hr·°F (W/m K)	Nominal Resistance hr·ft ² ·°F/Btu (m ² K/W)	Density lb/ft ³ (kg/m ³)	Specific Heat Btu/lb·°F (J/kg K)
1	Interior Film ¹	-	-	R-0.7 (0.12 RSI)	-	-
2	Gypsum Board	1/2" (13)	1.1 (0.16)	R-0.5 (0.09 RSI)	50 (800)	0.26 (1090)
3	Cellulose Insulation in Stud Cavity	6" (152)	0.30 (0.043)	R-20.0 (3.52 RSI)	1.2 (19)	0.33 (1400)
4	6" x 1 5/8" Steel Studs	18 Gauge	430 (62)	-	489 (7830)	0.12 (500)
5	Exterior Sheathing	1/2" (13)	1.1 (0.16)	R-0.5 (0.09 RSI)	50 (800)	0.26 (1090)
6	SOPREMA SOPRASEAL STICK VP membrane	-	-	-	-	-
7	SOPRA-ISO V PLUS Exterior Insulation	Varies	0.17 (0.024)	R-6.0 to R-42.0 (1.06 RSI to 7.40 RSI)	1.9 (30)	0.36 (1500)
8	Thermal Break	1/2" (13)	0.13 (0.019)	-	2.1 (33)	0.50 (2100)
9	ACS-S Thermal Clip	16 Gauge	118 (17)	-	500 (8000)	0.13 (530)
10	Fastener	1/4" (6.4) Ø	347 (50)	-	489 (7830)	0.12 (500)
11	Girt	18 Gauge	430 (62)	-	489 (7830)	0.12 (500)
12	Cladding with 1/2" vented airspace incorporated into exterior heat transfer coefficient					
13	Exterior Film ¹	-	-	R-0.7 (0.12 RSI)	-	-

¹ Value selected from table 1, p. 26.1 of 2009 ASHRAE Handbook – Fundamentals depending on surface orientation

Detail 5.1.129

Exterior and Interior Insulated 6" x 1 5/8" Steel Stud (16" o.c.) Wall Assembly with Mineral Wool and ACS-S Thermal Clip Supporting Metal Cladding with R-20 Cellulose Insulation in Stud Cavity - Clear Wall

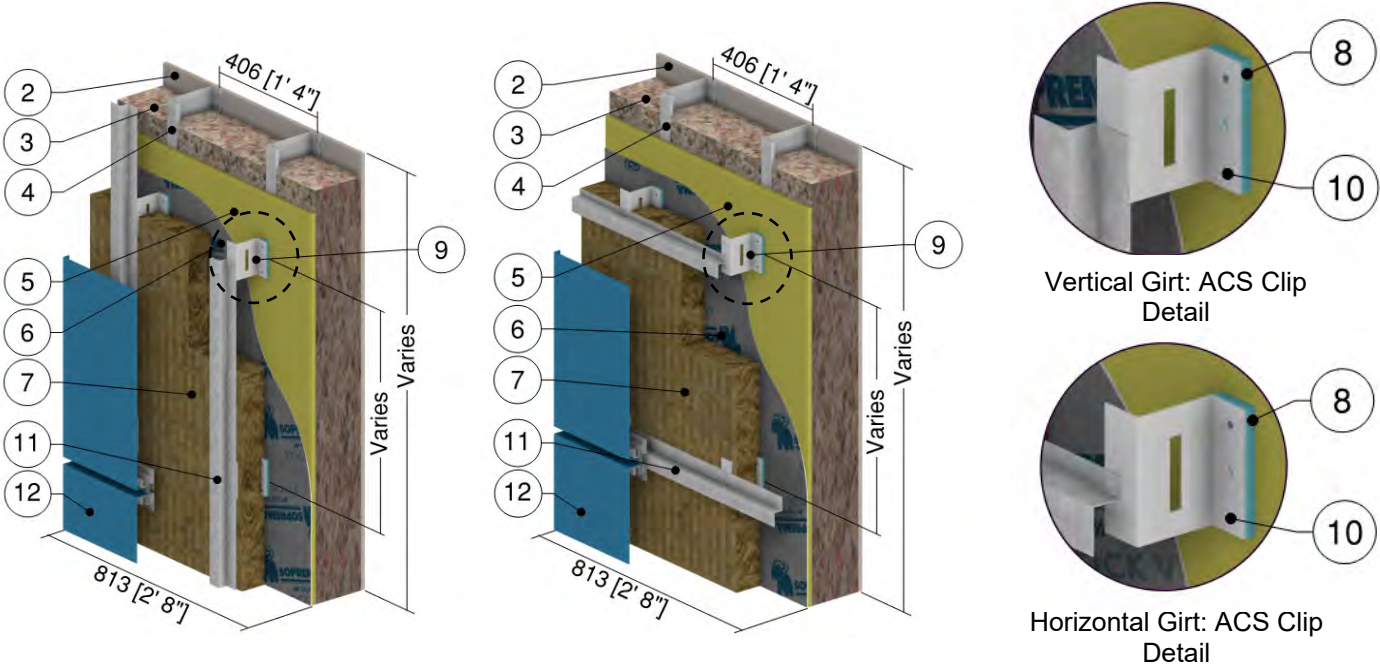

ID	Component	Thickness Inches (mm)	Conductivity Btu-in / ft ² ·hr·°F (W/m K)	Nominal Resistance hr·ft ² ·°F/Btu (m ² K/W)	Density lb/ft ³ (kg/m ³)	Specific Heat Btu/lb·°F (J/kg K)
1	Interior Film ¹	-	-	R-0.7 (0.12 RSI)	-	-
2	Gypsum Board	1/2" (13)	1.1 (0.16)	R-0.5 (0.09 RSI)	50 (800)	0.26 (1090)
3	Cellulose Insulation in Stud Cavity	6" (152)	0.30 (0.043)	R-20.0 (3.52 RSI)	1.2 (19)	0.33 (1400)
4	6" x 1 5/8" Steel Studs	18 Gauge	430 (62)	-	489 (7830)	0.12 (500)
5	Exterior Sheathing	1/2" (13)	1.1 (0.16)	R-0.5 (0.09 RSI)	50 (800)	0.26 (1090)
6	SOPREMA SOPRASEAL STICK VP membrane	-	-	-	-	-
7	Exterior Mineral Wool Insulation	Varies	0.23 (0.034)	R-4.3 to R-34.4 (0.76 RSI to 6.06 RSI)	1.8 (28)	0.29 (1220)
8	Thermal Break	1/2" (13)	0.13 (0.019)	-	2.1 (33)	0.50 (2100)
9	ACS-S Thermal Clip	16 Gauge	118 (17)	-	500 (8000)	0.13 (530)
10	Fastener	1/4" (6.4) Ø	347 (50)	-	489 (7830)	0.12 (500)
11	Girt	18 Gauge	430 (62)	-	489 (7830)	0.12 (500)
12	Cladding with 1/2" vented airspace incorporated into exterior heat transfer coefficient					
13	Exterior Film ¹	-	-	R-0.7 (0.12 RSI)	-	-

¹ Value selected from table 1, p. 26.1 of 2009 ASHRAE Handbook – Fundamentals depending on surface orientation

Detail 5.1.130

Exterior and Interior Insulated 6" x 1 5/8" Steel Stud (24" o.c.) Wall Assembly with Mineral Wool and ACS-S Thermal Clip Supporting Metal Cladding with R-20 Cellulose Insulation in Stud Cavity - Clear Wall

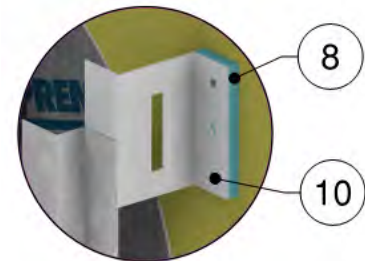
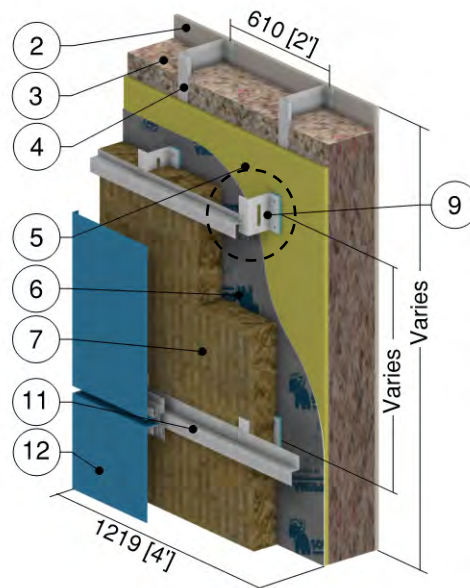
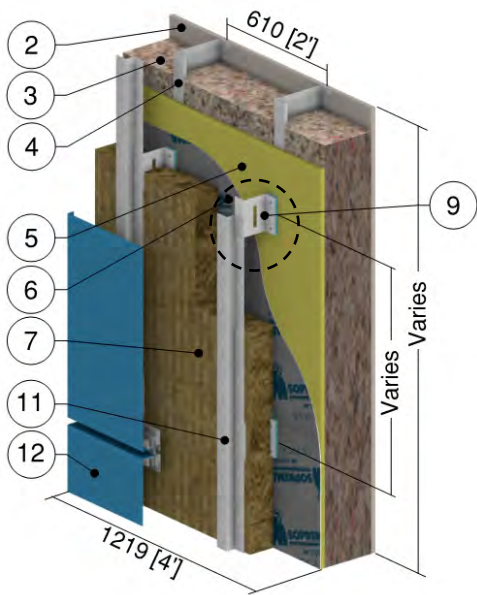

Vertical Girt: ACS Clip Detail

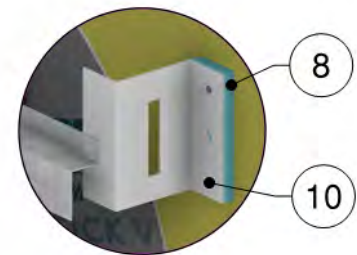

Horizontal Girt: ACS Clip Detail

ID	Component	Thickness Inches (mm)	Conductivity Btu-in / ft ² ·hr·°F (W/m K)	Nominal Resistance hr·ft ² ·°F/Btu (m ² K/W)	Density lb/ft ³ (kg/m ³)	Specific Heat Btu/lb·°F (J/kg K)
1	Interior Film ¹	-	-	R-0.7 (0.12 RSI)	-	-
2	Gypsum Board	1/2" (13)	1.1 (0.16)	R-0.5 (0.09 RSI)	50 (800)	0.26 (1090)
3	Cellulose Insulation in Stud Cavity	6" (152)	0.30 (0.043)	R-20.0 (3.52 RSI)	1.2 (19)	0.33 (1400)
4	6" x 1 5/8" Steel Studs	18 Gauge	430 (62)	-	489 (7830)	0.12 (500)
5	Exterior Sheathing	1/2" (13)	1.1 (0.16)	R-0.5 (0.09 RSI)	50 (800)	0.26 (1090)
6	SOPREMA SOPRASEAL STICK VP membrane	-	-	-	-	-
7	Exterior Mineral Wool Insulation	Varies	0.23 (0.034)	R-4.3 to R-34.4 (0.76 RSI to 6.06 RSI)	1.8 (28)	0.29 (1220)
8	Thermal Break	1/2" (13)	0.13 (0.019)	-	2.1 (33)	0.50 (2100)
9	ACS-S Thermal Clip	16 Gauge	118 (17)	-	500 (8000)	0.13 (530)
10	Fastener	1/4" (6.4) Ø	347 (50)	-	489 (7830)	0.12 (500)
11	Girt	18 Gauge	430 (62)	-	489 (7830)	0.12 (500)
12	Cladding with 1/2" vented airspace incorporated into exterior heat transfer coefficient					
13	Exterior Film ¹	-	-	R-0.7 (0.12 RSI)	-	-

¹ Value selected from table 1, p. 26.1 of 2009 ASHRAE Handbook – Fundamentals depending on surface orientation

Detail 5.1.131

Exterior Insulated 6" x 1 5/8" Steel Stud (16" o.c.) Wall Assembly with Protected SOPREMA SOPRA-ISO V ALU and ACS-S Thermal Clip Supporting Metal Cladding - Clear Wall

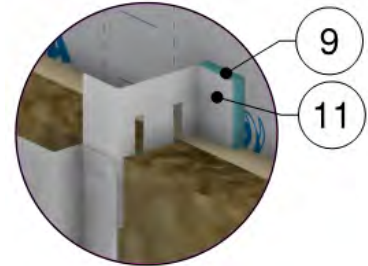
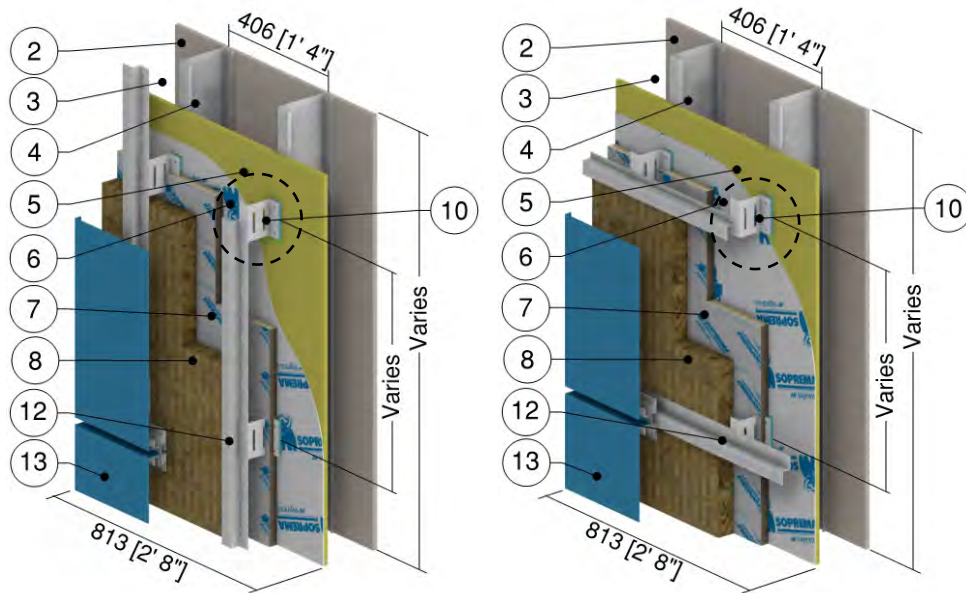

Vertical Girt: ACS Clip Detail

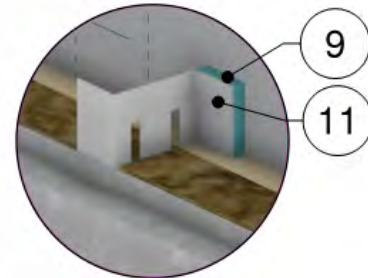

Horizontal Girt: ACS Clip Detail

ID	Component	Thickness Inches (mm)	Conductivity Btu-in / ft ² ·hr·°F (W/m K)	Nominal Resistance hr·ft ² ·°F/Btu (m ² K/W)	Density lb/ft ³ (kg/m ³)	Specific Heat Btu/lb·°F (J/kg K)
1	Interior Film ¹	-	-	R-0.7 (0.12 RSI)	-	-
2	Gypsum Board	1/2" (13)	1.1 (0.16)	R-0.5 (0.09 RSI)	50 (800)	0.26 (1090)
3	Air in Stud Cavity	6" (152)	-	R-0.9 (0.16 RSI)	0.075 (1.2)	0.24 (1000)
4	6" x 1 5/8" Steel Studs	18 Gauge	430 (62)	-	489 (7830)	0.12 (500)
5	Exterior Sheathing	1/2" (13)	1.1 (0.16)	R-0.5 (0.09 RSI)	50 (800)	0.26 (1090)
6	SOPREMA SOPRASEAL STICK 1100T membrane installed with SOPRASEAL STICK PRIMER	-	-	-	-	-
7	SOPRA-ISO V ALU Exterior Insulation	Varies	0.15 (0.022)	R-6.5 to R-39.0 (1.14 RSI to 6.87 RSI)	1.9 (30)	0.36 (1500)
8	Exterior Mineral Wool Insulation	2" (50)	0.23 (0.034)	R-8.6 (1.51 RSI)	1.8 (28)	0.29 (1220)
9	Thermal Break	1/2" (13)	0.13 (0.019)	-	2.1 (33)	0.50 (2100)
10	ACS-S Thermal Clip	16 Gauge	118 (17)	-	500 (8000)	0.13 (530)
11	Fastener	1/4" (6.4) Ø	347 (50)	-	489 (7830)	0.12 (500)
12	Girt	18 Gauge	430 (62)	-	489 (7830)	0.12 (500)
13	Cladding with 1/2" vented airspace incorporated into exterior heat transfer coefficient					
14	Exterior Film ¹	-	-	R-0.7 (0.12 RSI)	-	-

¹ Value selected from table 1, p. 26.1 of 2009 ASHRAE Handbook – Fundamentals depending on surface orientation

Detail 5.1.132

Exterior Insulated 6" x 1 5/8" Steel Stud (24" o.c.) Wall Assembly with Protected SOPREMA SOPRA-ISO V ALU and ACS-S Thermal Clip Supporting Metal Cladding - Clear Wall

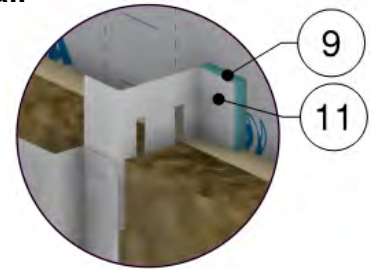
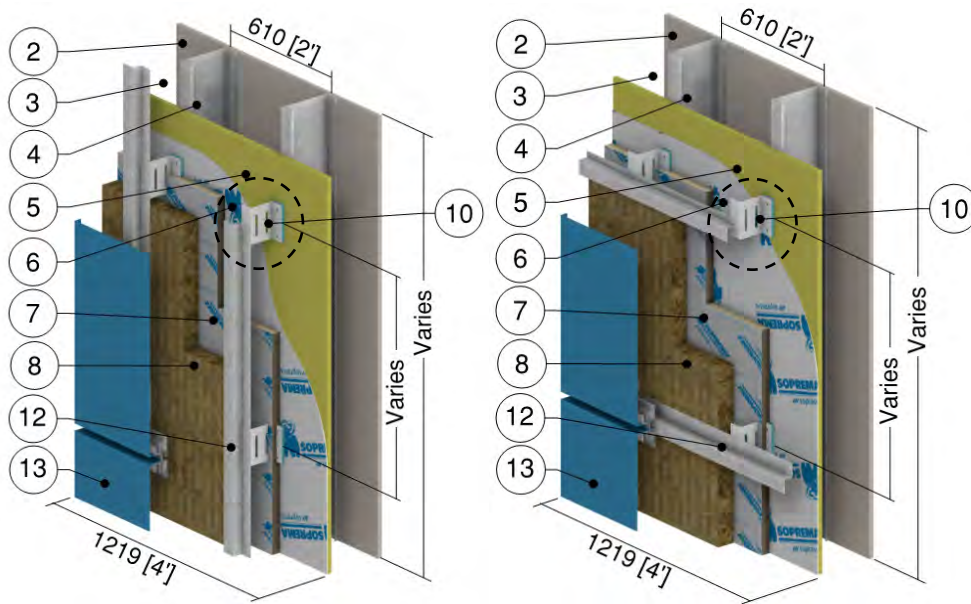

Vertical Girt: ACS Clip Detail

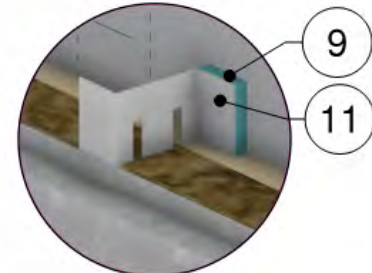

Horizontal Girt: ACS Clip Detail

ID	Component	Thickness Inches (mm)	Conductivity Btu-in / ft ² ·hr·°F (W/m K)	Nominal Resistance hr·ft ² ·°F/Btu (m ² K/W)	Density lb/ft ³ (kg/m ³)	Specific Heat Btu/lb·°F (J/kg K)
1	Interior Film ¹	-	-	R-0.7 (0.12 RSI)	-	-
2	Gypsum Board	1/2" (13)	1.1 (0.16)	R-0.5 (0.09 RSI)	50 (800)	0.26 (1090)
3	Air in Stud Cavity	6" (152)	-	R-0.9 (0.16 RSI)	0.075 (1.2)	0.24 (1000)
4	6" x 1 5/8" Steel Studs	18 Gauge	430 (62)	-	489 (7830)	0.12 (500)
5	Exterior Sheathing	1/2" (13)	1.1 (0.16)	R-0.5 (0.09 RSI)	50 (800)	0.26 (1090)
6	SOPREMA SOPRASEAL STICK 1100T membrane installed with SOPRASEAL STICK PRIMER	-	-	-	-	-
7	SOPRA-ISO V ALU Exterior Insulation	Varies	0.15 (0.022)	R-6.5 to R-39.0 (1.14 RSI to 6.87 RSI)	1.9 (30)	0.36 (1500)
8	Exterior Mineral Wool Insulation	2" (50)	0.23 (0.034)	R-8.6 (1.51 RSI)	1.8 (28)	0.29 (1220)
9	Thermal Break	1/2" (13)	0.13 (0.019)	-	2.1 (33)	0.50 (2100)
10	ACS-S Thermal Clip	16 Gauge	118 (17)	-	500 (8000)	0.13 (530)
11	Fastener	1/4" (6.4) Ø	347 (50)	-	489 (7830)	0.12 (500)
12	Girt	18 Gauge	430 (62)	-	489 (7830)	0.12 (500)
13	Cladding with 1/2" vented airspace incorporated into exterior heat transfer coefficient					
14	Exterior Film ¹	-	-	R-0.7 (0.12 RSI)	-	-

¹ Value selected from table 1, p. 26.1 of 2009 ASHRAE Handbook – Fundamentals depending on surface orientation

Detail 5.1.133

Exterior and Interior Insulated 6" x 1 5/8" Steel Stud (16" o.c.) Wall Assembly with Protected SOPREMA SOPRA-ISO V PLUS and ACS-S Thermal Clip Supporting Metal Cladding with R-20 Cellulose Insulation in Stud Cavity - Clear Wall

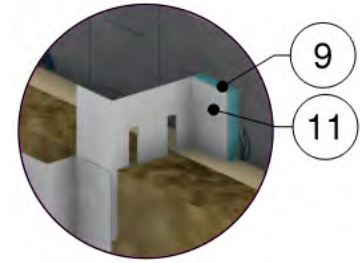
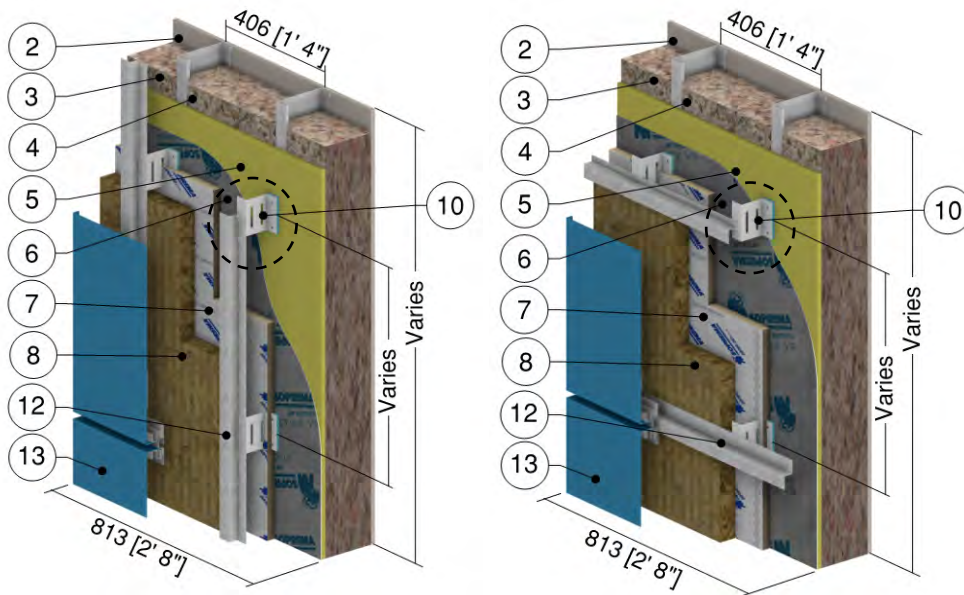

Vertical Girt: ACS Clip Detail

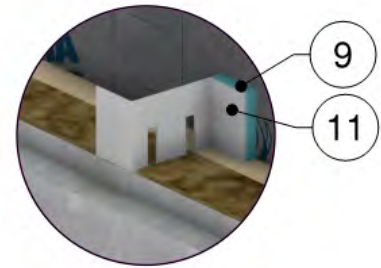

Horizontal Girt: ACS Clip Detail

ID	Component	Thickness Inches (mm)	Conductivity Btu-in / ft ² -hr-°F (W/m K)	Nominal Resistance hr-ft ² -°F/Btu (m ² K/W)	Density lb/ft ³ (kg/m ³)	Specific Heat Btu/lb-°F (J/kg K)
1	Interior Film ¹	-	-	R-0.7 (0.12 RSI)	-	-
2	Gypsum Board	1/2" (13)	1.1 (0.16)	R-0.5 (0.09 RSI)	50 (800)	0.26 (1090)
3	Cellulose Insulation in Stud Cavity	6" (152)	0.30 (0.043)	R-20.0 (3.52 RSI)	1.2 (19)	0.33 (1400)
4	6" x 1 5/8" Steel Studs	18 Gauge	430 (62)	-	489 (7830)	0.12 (500)
5	Exterior Sheathing	1/2" (13)	1.1 (0.16)	R-0.5 (0.09 RSI)	50 (800)	0.26 (1090)
6	SOPREMA SOPRASEAL STICK VP membrane	-	-	-	-	-
7	SOPRA-ISO V PLUS Exterior Insulation	Varies	0.17 (0.024)	R-6.0 to R-30.0 (1.06 RSI to 5.28 RSI)	1.9 (30)	0.36 (1500)
8	Exterior Mineral Wool Insulation	2" (50)	0.23 (0.034)	R-8.6 (1.51 RSI)	1.8 (28)	0.29 (1220)
9	Thermal Break	1/2" (13)	0.13 (0.019)	-	2.1 (33)	0.50 (2100)
10	ACS-S Thermal Clip	16 Gauge	118 (17)	-	500 (8000)	0.13 (530)
11	Fastener	1/4" (6.4) Ø	347 (50)	-	489 (7830)	0.12 (500)
12	Girt	18 Gauge	430 (62)	-	489 (7830)	0.12 (500)
13	Cladding with 1/2" vented airspace incorporated into exterior heat transfer coefficient					
14	Exterior Film ¹	-	-	R-0.7 (0.12 RSI)	-	-

¹ Value selected from table 1, p. 26.1 of 2009 ASHRAE Handbook – Fundamentals depending on surface orientation

Detail 5.1.134

Exterior and Interior Insulated 6" x 1 5/8" Steel Stud (24" o.c.) Wall Assembly with Protected SOPREMA SOPRA-ISO V PLUS and ACS-S Thermal Clip Supporting Metal Cladding with R-20 Cellulose Insulation in Stud Cavity - Clear Wall

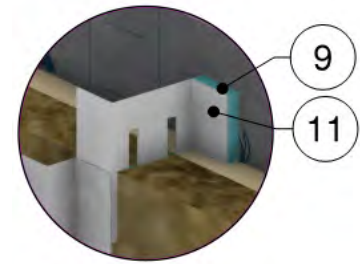
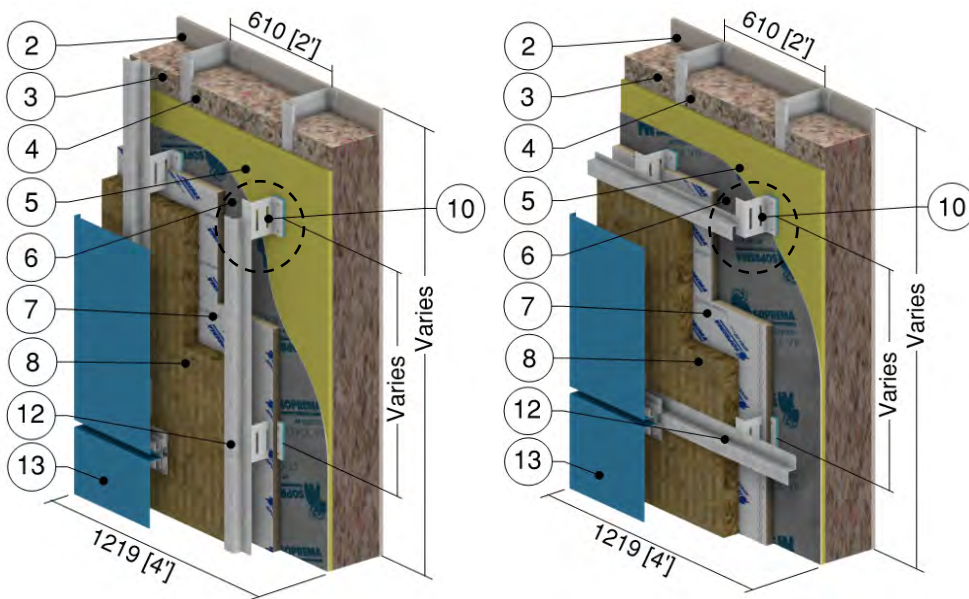

Vertical Girt: ACS Clip Detail

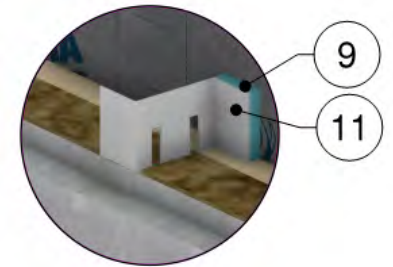

Horizontal Girt: ACS Clip Detail

ID	Component	Thickness Inches (mm)	Conductivity Btu-in / ft ² -hr-°F (W/m K)	Nominal Resistance hr-ft ² -°F/Btu (m ² K/W)	Density lb/ft ³ (kg/m ³)	Specific Heat Btu/lb-°F (J/kg K)
1	Interior Film ¹	-	-	R-0.7 (0.12 RSI)	-	-
2	Gypsum Board	1/2" (13)	1.1 (0.16)	R-0.5 (0.09 RSI)	50 (800)	0.26 (1090)
3	Cellulose Insulation in Stud Cavity	6" (152)	0.30 (0.043)	R-20.0 (3.52 RSI)	1.2 (19)	0.33 (1400)
4	6" x 1 5/8" Steel Studs	18 Gauge	430 (62)	-	489 (7830)	0.12 (500)
5	Exterior Sheathing	1/2" (13)	1.1 (0.16)	R-0.5 (0.09 RSI)	50 (800)	0.26 (1090)
6	SOPREMA SOPRASEAL STICK VP membrane	-	-	-	-	-
7	SOPRA-ISO V PLUS Exterior Insulation	Varies	0.17 (0.024)	R-6.0 to R-30.0 (1.06 RSI to 5.28 RSI)	1.9 (30)	0.36 (1500)
8	Exterior Mineral Wool Insulation	2" (50)	0.23 (0.034)	R-8.6 (1.51 RSI)	1.8 (28)	0.29 (1220)
9	Thermal Break	1/2" (13)	0.13 (0.019)	-	2.1 (33)	0.50 (2100)
10	ACS-S Thermal Clip	16 Gauge	118 (17)	-	500 (8000)	0.13 (530)
11	Fastener	1/4" (6.4) Ø	347 (50)	-	489 (7830)	0.12 (500)
12	Girt	18 Gauge	430 (62)	-	489 (7830)	0.12 (500)
13	Cladding with 1/2" vented airspace incorporated into exterior heat transfer coefficient					
14	Exterior Film ¹	-	-	R-0.7 (0.12 RSI)	-	-

¹ Value selected from table 1, p. 26.1 of 2009 ASHRAE Handbook – Fundamentals depending on surface orientation

Detail 5.1.135

Exterior Insulated 6" x 1 5/8" Steel Stud (16" o.c.) Wall Assembly with U-Kon ND-062 Brackets and Vertical Rail System Supporting Metal Cladding - Clear Wall

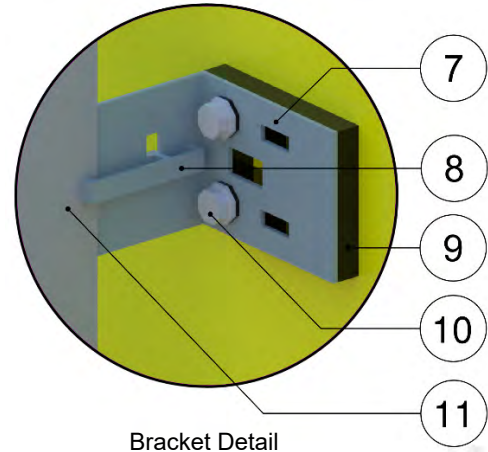
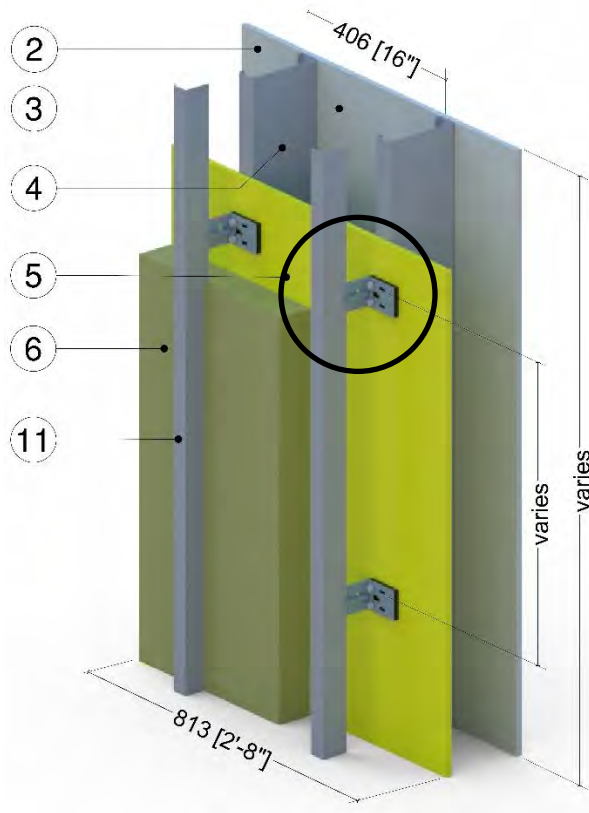

Exterior Insulation Thickness for Bracket Sizes

Bracket Size	Exterior Insulation Thickness in (mm)
80	3 (76)
100	4 (102)
120	5 (127)
150	6 (152)
250	10 (254)

ID	Component	Thickness Inches (mm)	Conductivity Btu-in / ft ² ·hr·°F (W/m K)	Nominal Resistance hr·ft ² ·°F/Btu (m ² K/W)	Density lb/ft ³ (kg/m ³)	Specific Heat Btu/lb·°F (J/kg K)
1	Interior Film ¹	-	-	R-0.7 (0.12 RSI)	-	-
2	Gypsum Board	1/2" (13)	1.1 (0.16)	R-0.5 (0.09 RSI)	50 (800)	0.26 (1090)
3	Air in Stud Cavity	6" (152)	-	R-0.9 (0.16 RSI)	0.075 (1.2)	0.24 (1000)
4	6" x 1 5/8" Steel Studs	18 Gauge	430 (62)	-	489 (7830)	0.12 (500)
5	Exterior Sheathing	1/2" (13)	1.1 (0.16)	R-0.5 (0.09 RSI)	50 (800)	0.26 (1090)
6	Exterior Mineral Wool Insulation	Varies	0.24 (0.034)	R-12.6 to R-42.0 (2.22 to 7.40 RSI)	4 (64)	0.20 (850)
7	U-Kon ND-062 Bracket	14 Gauge	118 (17)	-	499 (8000)	0.12 (500)
8	U-Kon Bracket to Rail Thumb	18 Gauge	430 (147)	-	-	-
9	Thermal Isolator	3/8" (10)	0.11 (0.12)	-	-	-
10	Fastener	3/8" (10) Ø	118 (17)	-	499 (8000)	0.12 (500)
11	Vertical Rail	18 Gauge	430 (147)	-	-	-
12	Cladding with vented airspace incorporated into exterior heat transfer coefficient					
13	Exterior Film ¹	-	-	R-0.7 (0.12 RSI)	-	-

¹ Value selected from table 1, p. 26.1 of 2009 ASHRAE Handbook – Fundamentals depending on surface orientation

Detail 5.2.1

Exterior Insulated 3 5/8" x 1 5/8" Steel Stud (16" o.c.) Wall Assembly with Horizontal Z-Girts (24" o.c.) Supporting Metal Cladding – Intermediate Floor Intersection

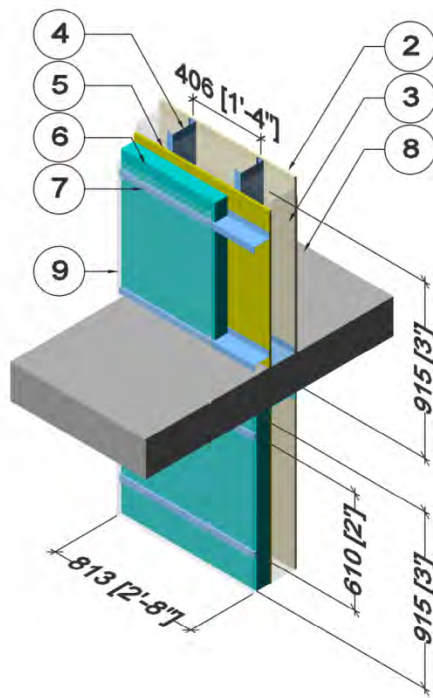

ID	Component	Thickness Inches (mm)	Conductivity Btu-in / ft ² ·hr·°F (W/m K)	Nominal Resistance hr·ft ² ·°F/Btu (m ² K/W)	Density lb/ft ³ (kg/m ³)	Specific Heat Btu/lb·°F (J/kg K)
1	Interior Film ¹	-	-	R-0.6 to R-0.9 (0.11 RSI to 0.16 RSI)	-	-
2	Gypsum Board	1/2" (13)	1.1 (0.16)	R-0.5 (0.08 RSI)	50 (800)	0.26 (1090)
3	Air in Stud Cavity	3 5/8" (92)	-	R-0.9 (0.16 RSI)	0.075 (1.2)	0.24 (1000)
4	3 5/8" x 1 5/8" Steel Studs with Top and Bottom Tracks	18 gauge	430 (62)	-	489 (7830)	0.12 (500)
5	Exterior Sheathing	1/2" (13)	1.1 (0.16)	R-0.5 (0.08 RSI)	50 (800)	0.26 (1090)
6	Exterior Insulation	Varies	-	R-5 to R-25 (0.88 to 4.4 RSI)	1.8 (28)	0.29 (1220)
7	Horizontal Z-Girts w/ 1 1/2" Flange	18 gauge	430 (62)	-	489 (7830)	0.12 (500)
8	Concrete Slab	8" (203)	12.5 (1.8)	-	140 (2250)	0.20 (850)
9	Metal cladding with 1/2" (13mm) vented air space is incorporated into exterior heat transfer coefficient					
10	Exterior Film ¹	-	-	R-0.2 to R-0.7 (0.03 RSI to 0.12 RSI)	-	-

¹ Value selected from table 1, p. 26.1 of 2009 ASHRAE Handbook – Fundamentals depending on surface orientation

Detail 5.2.2

Exterior Insulated 3 5/8" x 1 5/8" Steel Stud (16" o.c.) Wall Assembly with Horizontal Z-Girts (24" o.c.) Supporting Metal Cladding – Intermediate Floor Intersection with Top Side Insulation

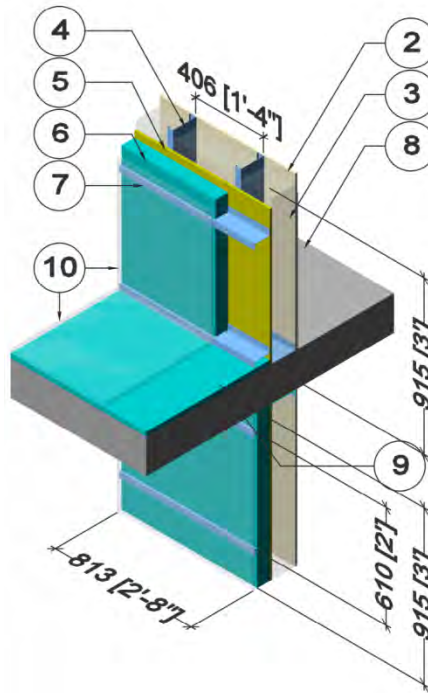

ID	Component	Thickness Inches (mm)	Conductivity Btu-in / ft ² -hr-°F (W/m K)	Nominal Resistance hr-ft ² -°F/Btu (m ² K/W)	Density lb/ft ³ (kg/m ³)	Specific Heat Btu/lb-°F (J/kg K)
1	Interior Film ¹	-	-	R-0.6 to R-0.9 (0.11 RSI to 0.16 RSI)	-	-
2	Gypsum Board	1/2" (13)	1.1 (0.16)	R-0.5 (0.08 RSI)	50 (800)	0.26 (1090)
3	Air in Stud Cavity	3 5/8" (92)	-	R-0.9 (0.16 RSI)	0.075 (1.2)	0.24 (1000)
4	3 5/8" x 1 5/8" Steel Studs with Top and Bottom Tracks	18 gauge	430 (62)	-	489 (7830)	0.12 (500)
5	Exterior Sheathing	1/2" (13)	1.1 (0.16)	R-0.5 (0.08 RSI)	50 (800)	0.26 (1090)
6	Exterior Insulation	3" (76)	-	R-15 (2.64 RSI)	1.8 (28)	0.29 (1220)
7	Horizontal Z-Girts w/ 1 1/2" Flange	18 gauge	430 (62)	-	489 (7830)	0.12 (500)
8	Concrete Slab	8" (203)	12 (1.8)	-	140 (2250)	0.20 (850)
9	Exterior Balcony Insulation ²	1" (25)	-	R-5 (0.88 RSI)	1.8 (28)	0.29 (1220)
10	Metal cladding/flashing/ finished soffit/pavers with vented air space is incorporated into exterior heat transfer coefficient					
11	Exterior Film ¹	-	-	R-0.2 to R-0.7 (0.03 RSI to 0.12 RSI)	-	-

¹ Value selected from table 1, p. 26.1 of 2009 ASHRAE Handbook – Fundamentals depending on surface orientation

² Exterior Balcony Insulation Length varies at 0" (0mm), 7 7/8" (200mm), 15 3/4" (400mm), 31 1/2" (800mm) from wall

Detail 5.2.3

Exterior Insulated 3 5/8" x 1 5/8" Steel Stud (16" o.c.) Wall Assembly with Horizontal Z-Girts (24" o.c.) Supporting Metal Cladding – Intermediate Floor Intersection with Top & Under Side Insulation

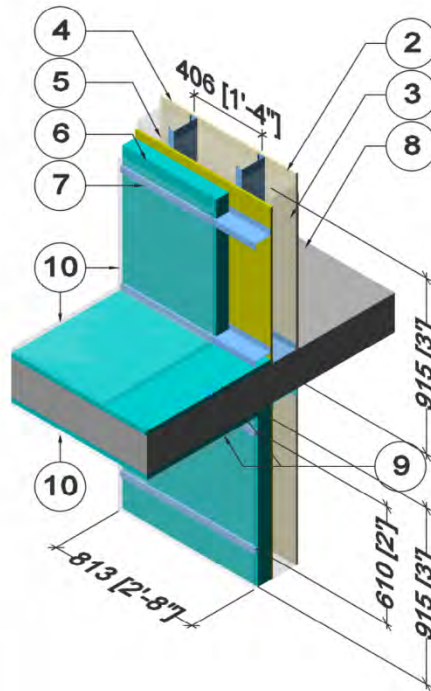

ID	Component	Thickness Inches (mm)	Conductivity Btu·in / ft ² ·hr·°F (W/m K)	Nominal Resistance hr·ft ² ·°F/Btu (m ² K/W)	Density lb/ft ³ (kg/m ³)	Specific Heat Btu/lb·°F (J/kg K)
1	Interior Film ¹	-	-	R-0.6 to R-0.9 (0.11 RSI to 0.16 RSI)	-	-
2	Gypsum Board	1/2" (13)	1.1 (0.16)	R-0.5 (0.08 RSI)	50 (800)	0.26 (1090)
3	Air in Stud Cavity	3 5/8" (92)	-	R-0.9 (0.16 RSI)	0.075 (1.2)	0.24 (1000)
4	3 5/8" x 1 5/8" Steel Studs with Top and Bottom Tracks	18 gauge	430 (62)	-	489 (7830)	0.12 (500)
5	Exterior Sheathing	1/2" (13)	1.1 (0.16)	R-0.5 (0.08 RSI)	50 (800)	0.26 (1090)
6	Exterior Insulation	3" (76)	-	R-15 (2.64 RSI)	1.8 (28)	0.29 (1220)
7	Horizontal Z-Girts w/ 1 1/2" Flange	18 gauge	430 (62)	-	489 (7830)	0.12 (500)
8	Concrete Slab	8" (203)	12.5 (1.8)	-	140 (2250)	0.20 (850)
9	Exterior Balcony & Soffit Insulation ²	1" (25)	-	R-5 (0.88 RSI)	1.8 (28)	0.29 (1220)
10	Metal cladding/flushing/ finished soffit/pavers with vented air space is incorporated into exterior heat transfer coefficient					
11	Exterior Film ¹	-	-	R-0.2 to R-0.7 (0.03 RSI to 0.12 RSI)	-	-

¹ Value selected from table 1, p. 26.1 of 2009 ASHRAE Handbook – Fundamentals depending on surface orientation

² Exterior Balcony Insulation Length varies at 0" (0mm), 7 7/8" (200mm), 15 3/4" (400mm), 31 1/2" (800mm) from wall

Detail 5.2.4

Exterior Insulated 3 5/8" x 1 5/8" Steel Stud (16" o.c.) Wall Assembly with Horizontal Z-girts (24" o.c.) Supporting Metal Cladding – Uninsulated Intermediate Floor Intersection with Uninsulated Curb

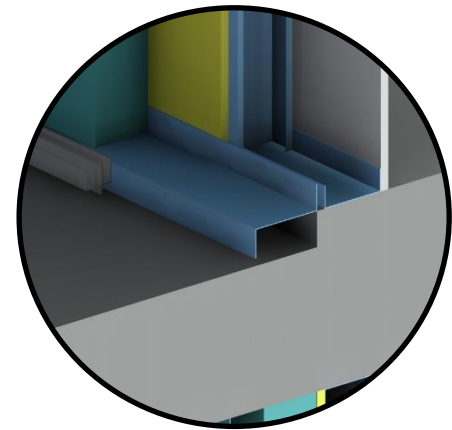
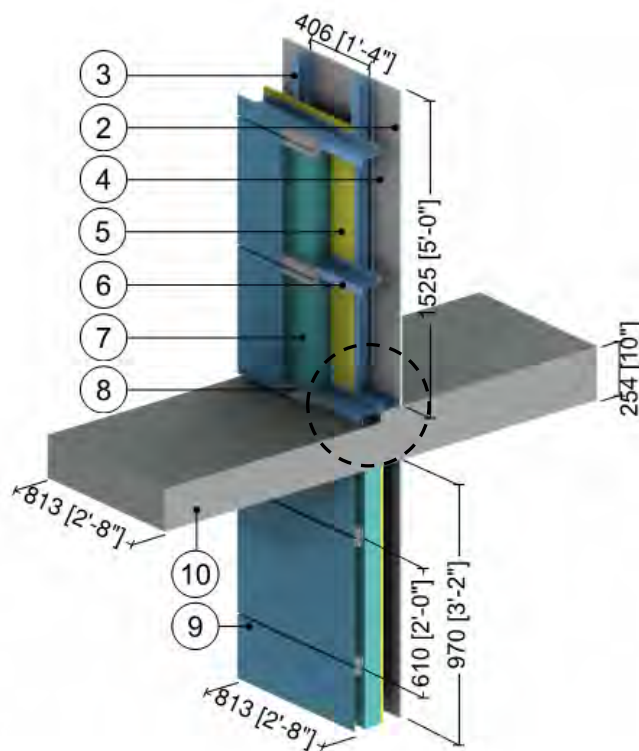

Balcony Stepdown Detail

ID	Component	Thickness Inches (mm)	Conductivity Btu·in / ft ² ·hr·°F (W/m K)	Nominal Resistance hr·ft ² ·°F/Btu (m ² K/W)	Density lb/ft ³ (kg/m ³)	Specific Heat Btu/lb·°F (J/kg K)
1	Interior Film ¹	-	-	R-0.6 to R-0.9 (0.11 RSI to 0.16 RSI)	-	-
2	Gypsum Board	1/2" (13)	1.1 (0.16)	R-0.5 (0.08 RSI)	50 (800)	0.26 (1090)
3	3 5/8" x 1 5/8" Steel Studs with Top and Bottom Tracks	18 Gauge	430 (62)	-	489 (7830)	0.12 (500)
4	Air in Stud Cavity	3 5/8" (92)	-	R-0.9 (0.16 RSI)	0.075 (1.2)	0.24 (1000)
5	Exterior Sheathing	1/2" (13)	1.1 (0.16)	R-0.5 (0.08 RSI)	50 (800)	0.26 (1090)
6	Horizontal Z-Girt with 1 1/2" Flange	18 Gauge	430 (62)	-	489 (7830)	0.12 (500)
7	Exterior Insulation	3" (76)	-	R-15 (2.64 RSI)	1.8 (28)	0.29 (1220)
8	Panel Clip	14 Gauge	430 (62)	-	489 (7830)	0.12 (500)
9	Metal Cladding with 1/2" vented airspace incorporated into exterior heat transfer coefficient					
10	Concrete Slab	8" (204)	12.5 (1.8)	-	140 (2250)	0.20 (850)
11	Exterior Film ¹	-	-	R-0.2 to R-0.7 (0.03 RSI to 0.12 RSI)	-	-

¹ Value selected from table 1, p. 26.1 of 2009 ASHRAE Handbook – Fundamentals depending on surface orientation

Detail 5.2.5

Exterior and Interior Insulated 3 5/8" x 1 5/8" Steel Stud (16" o.c.) Wall Assembly with Horizontal Z-girts (24" o.c.) Supporting Metal Cladding and R-12 Batt Insulation in Stud Cavity – Uninsulated Intermediate Floor Intersection with Uninsulated Curb

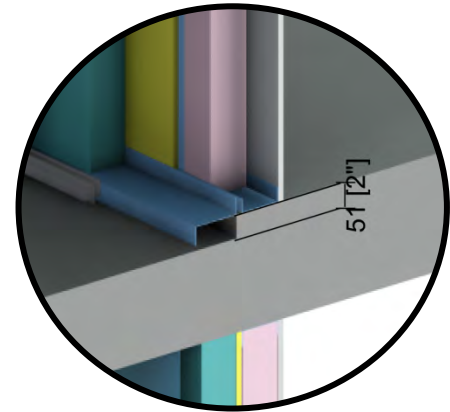
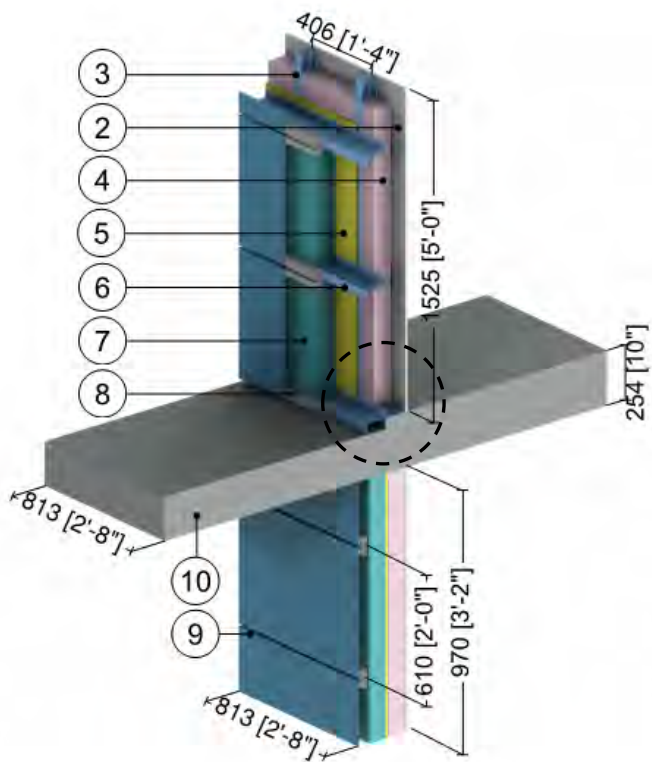

Balcony Stepdown Detail

ID	Component	Thickness Inches (mm)	Conductivity Btu-in / ft ² -hr-°F (W/m K)	Nominal Resistance hr-ft ² -°F/Btu (m ² K/W)	Density lb/ft ³ (kg/m ³)	Specific Heat Btu/lb-°F (J/kg K)
1	Interior Film ¹	-	-	R-0.6 to R-0.9 (0.11 RSI to 0.16 RSI)	-	-
2	Gypsum Board	1/2" (13)	1.1 (0.16)	R-0.5 (0.08 RSI)	50 (800)	0.26 (1090)
3	3 5/8" x 1 5/8" Steel Studs with Top and Bottom Tracks	18 Gauge	430 (62)	-	489 (7830)	0.12 (500)
4	Fiberglass Batt Insulation	3 5/8" (92)	0.30 (0.044)	R-12 (2.11 RSI)	0.9 (14)	0.17 (710)
5	Exterior Sheathing	1/2" (13)	1.1 (0.16)	R-0.5 (0.08 RSI)	50 (800)	0.26 (1090)
6	Horizontal Z-Girt with 1 1/2" Flange	18 Gauge	430 (62)	-	489 (7830)	0.12 (500)
7	Exterior Insulation	3" (76)	-	R-15 (2.64 RSI)	1.8 (28)	0.29 (1220)
8	Panel Clip	14 Gauge	430 (62)	-	489 (7830)	0.12 (500)
9	Metal Cladding with 1/2" vented airspace incorporated into exterior heat transfer coefficient					
10	Concrete Slab	8" (204)	12.5 (1.8)	-	140 (2250)	0.20 (850)
11	Exterior Film ¹	-	-	R-0.2 to R-0.7 (0.03 RSI to 0.12 RSI)	-	-

¹ Value selected from table 1, p. 26.1 of 2009 ASHRAE Handbook – Fundamentals depending on surface orientation

Detail 5.2.6

Exterior Insulated 3 5/8" x 1 5/8" Steel Stud (16" o.c.) Wall Assembly with Horizontal Z-girts (24" o.c.) Supporting Metal Cladding – Uninsulated Intermediate Floor Intersection with Insulated Curb

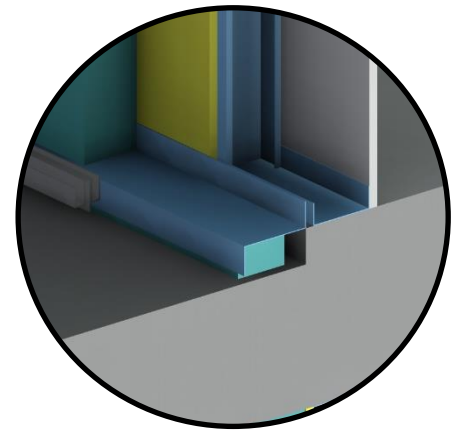
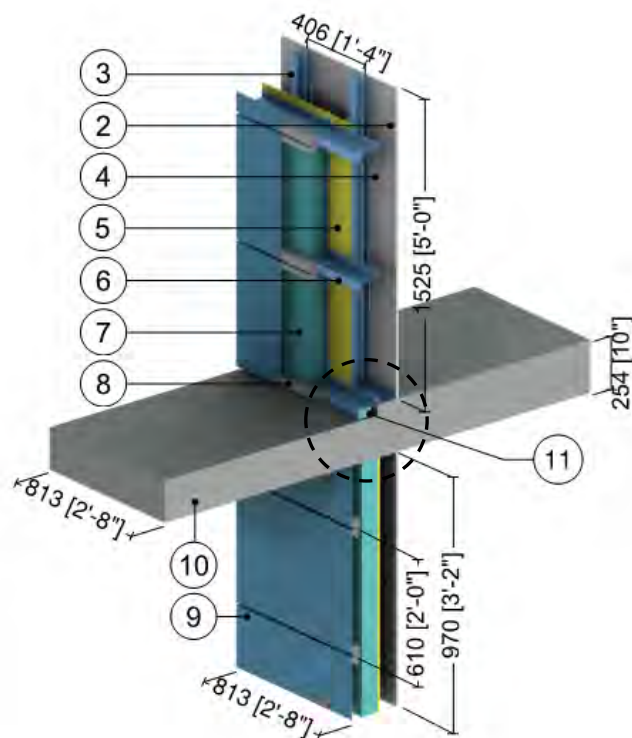

Balcony Stepdown Detail

ID	Component	Thickness Inches (mm)	Conductivity Btu-in / ft ² ·hr·°F (W/m K)	Nominal Resistance hr·ft ² ·°F/Btu (m ² K/W)	Density lb/ft ³ (kg/m ³)	Specific Heat Btu/lb·°F (J/kg K)
1	Interior Film ¹	-	-	R-0.6 to R-0.9 (0.11 RSI to 0.16 RSI)	-	-
2	Gypsum Board	1/2" (13)	1.1 (0.16)	R-0.5 (0.08 RSI)	50 (800)	0.26 (1090)
3	3 5/8" x 1 5/8" Steel Studs with Top and Bottom Tracks	18 Gauge	430 (62)	-	489 (7830)	0.12 (500)
4	Air in Stud Cavity	3 5/8" (92)	-	R-0.9 (0.16 RSI)	0.075 (1.2)	0.24 (1000)
5	Exterior Sheathing	1/2" (13)	1.1 (0.16)	R-0.5 (0.08 RSI)	50 (800)	0.26 (1090)
6	Horizontal Z-Girt with 1 1/2" Flange	18 Gauge	430 (62)	-	489 (7830)	0.12 (500)
7	Exterior Insulation	3" (76)	-	R-15 (2.64 RSI)	1.8 (28)	0.29 (1220)
8	Panel Clip	14 Gauge	430 (62)	-	489 (7830)	0.12 (500)
9	Metal Cladding with 1/2" vented airspace incorporated into exterior heat transfer coefficient					
10	Concrete Slab	8" (204)	12.5 (1.8)	-	140 (2250)	0.20 (850)
11	Curb Insulation	3" (76)	-	R-15 (2.64 RSI)	1.8 (28)	0.29 (1220)
12	Exterior Film ¹	-	-	R-0.2 to R-0.7 (0.03 RSI to 0.12 RSI)	-	-

¹ Value selected from table 1, p. 26.1 of 2009 ASHRAE Handbook – Fundamentals depending on surface orientation

Detail 5.2.7

Exterior and Interior Insulated 3 5/8" x 1 5/8" Steel Stud (16" o.c.) Wall Assembly with Horizontal Z-girts (24" o.c.) Supporting Metal Cladding and R-12 Batt Insulation in Stud Cavity – Uninsulated Intermediate Floor Intersection with Insulated Curb

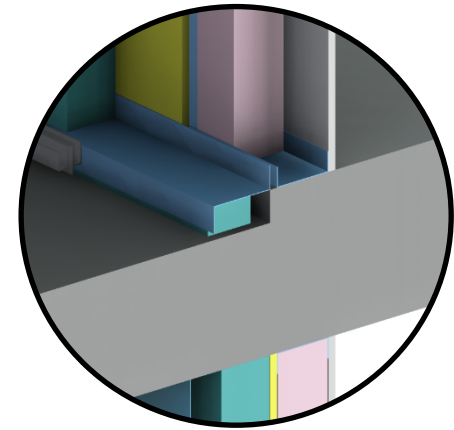
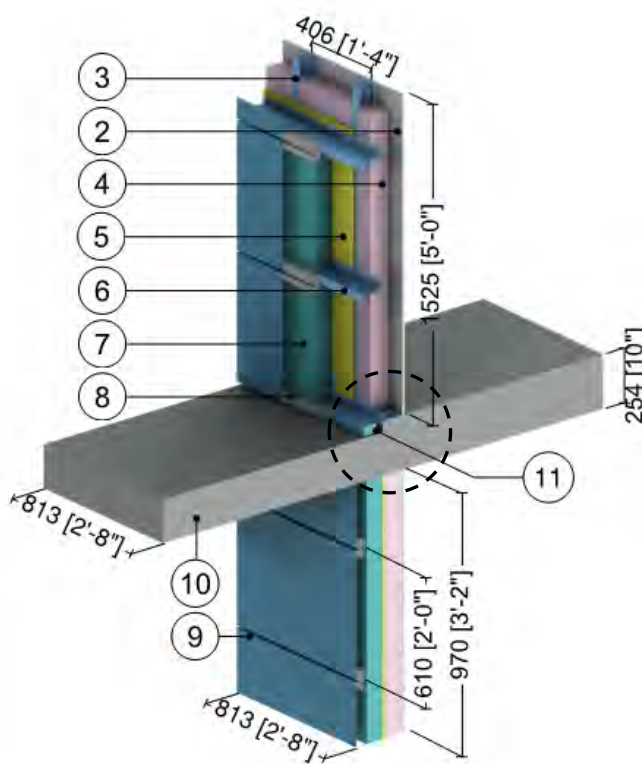

Balcony Stepdown Detail

ID	Component	Thickness Inches (mm)	Conductivity Btu-in / ft ² -hr-°F (W/m K)	Nominal Resistance hr-ft ² -°F/Btu (m ² K/W)	Density lb/ft ³ (kg/m ³)	Specific Heat Btu/lb-°F (J/kg K)
1	Interior Film ¹	-	-	R-0.6 to R-0.9 (0.11 RSI to 0.16 RSI)	-	-
2	Gypsum Board	1/2" (13)	1.1 (0.16)	R-0.5 (0.08 RSI)	50 (800)	0.26 (1090)
3	3 5/8" x 1 5/8" Steel Studs with Top and Bottom Tracks	18 Gauge	430 (62)	-	489 (7830)	0.12 (500)
4	Fiberglass Batt Insulation	3 5/8" (92)	0.30 (0.044)	R-12.0 (2.11 RSI)	0.9 (14)	0.17 (710)
5	Exterior Sheathing	1/2" (13)	1.1 (0.16)	R-0.5 (0.08 RSI)	50 (800)	0.26 (1090)
6	Horizontal Z-Girt with 1 1/2" Flange	18 Gauge	430 (62)	-	489 (7830)	0.12 (500)
7	Exterior Insulation	3" (76)	-	R-15 (2.64 RSI)	1.8 (28)	0.29 (1220)
8	Panel Clip	14 Gauge	430 (62)	-	489 (7830)	0.12 (500)
9	Metal Cladding with 1/2" vented airspace incorporated into exterior heat transfer coefficient					
10	Concrete Slab	8" (204)	12.5 (1.8)	-	140 (2250)	0.20 (850)
11	Curb Insulation	-	-	R-15 (2.64 RSI)	1.8 (28)	0.29 (1220)
12	Exterior Film ¹	-	-	R-0.2 to R-0.7 (0.03 RSI to 0.12 RSI)	-	-

¹ Value selected from table 1, p. 26.1 of 2009 ASHRAE Handbook – Fundamentals depending on surface orientation

Detail 5.2.8

Exterior and Interior Insulated 3 5/8" x 1 5/8" Steel Stud (16" o.c.) Wall Assembly with Vertical Z Girts (16" o.c.) Supporting Stucco Cladding and R-12 Batt Insulation in Stud Cavity – Uninsulated Intermediate Floor Intersection

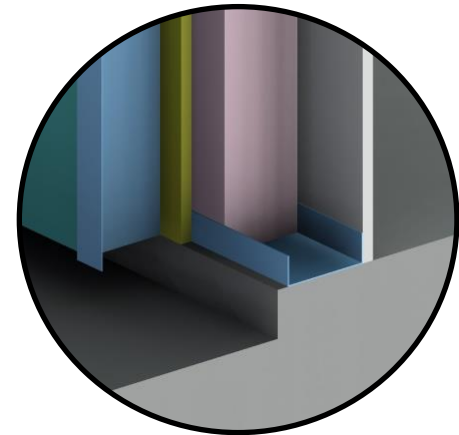
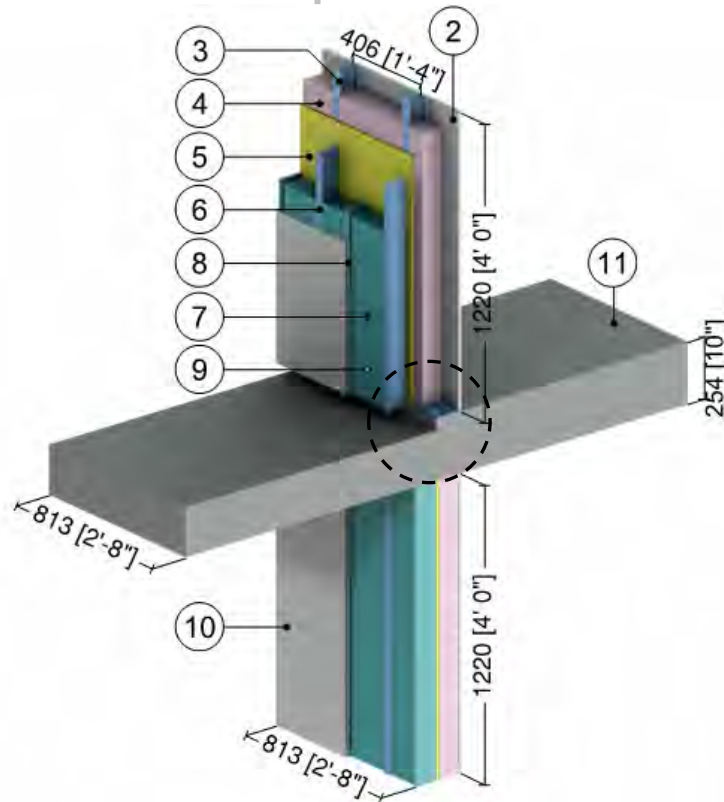

Balcony Stepdown Detail

ID	Component	Thickness Inches (mm)	Conductivity Btu-in / ft ² ·hr·°F (W/m K)	Nominal Resistance hr·ft ² ·°F/Btu (m ² K/W)	Density lb/ft ³ (kg/m ³)	Specific Heat Btu/lb·°F (J/kg K)
1	Interior Films ¹	-	-	R-0.6 to R-0.9 (0.11 RSI to 0.16 RSI)	-	-
2	Gypsum Board	1/2" (13)	1.1 (0.16)	R-0.5 (0.08 RSI)	50 (800)	0.26 (1090)
3	3 5/8" x 1 5/8" Steel Studs with Top and Bottom Tracks	18 Gauge	430 (62)	-	489 (7830)	0.12 (500)
4	Fiberglass Batt Insulation	3 5/8" (92)	0.30 (0.044)	R-12 (2.1 RSI)	0.9 (14)	0.17 (710)
5	Exterior Sheathing	1/2" (13)	1.1 (0.16)	R-0.5 (0.08 RSI)	50 (800)	0.26 (1090)
6	Vertical Z-Girts with 1 1/2" Flange	18 Gauge	430 (62)	-	489 (7830)	0.12 (500)
7	Exterior Insulation	Varies	-	R-10 to R-15 (1.76 RSI to 2.64 RSI)	1.8 (28)	0.29 (1220)
8	Rigid Insulation Bracing	Varies	0.2 (0.29)	-	1.8 (28)	0.29 (1220)
9	Rainscreen Cavity	1/2" (13)	-	R-0.5 (0.09 RSI)	0.075 (1.2)	0.24 (1000)
10	Stucco Cement with Breather Board	1/2" (13)	6 (0.9)	R-0.1 (0.01 RSI)	120 (1922)	0.20 (850)
11	Concrete Slab	8" (203)	12.5 (1.8)	-	140 (2250)	0.20 (850)
12	Exterior Film ¹	-	-	R-0.2 (0.03 RSI)	-	-

¹ Value selected from table 1, p. 26.1 of 2009 ASHRAE Handbook – Fundamentals depending on surface orientation

Detail 5.2.9

Exterior Insulated 3 5/8" x 1 5/8" Steel Stud (16" o.c.) Drained EIFS Wall Assembly – Isokorb CM20 Thermally Broken Slab Projection without Concrete Curb

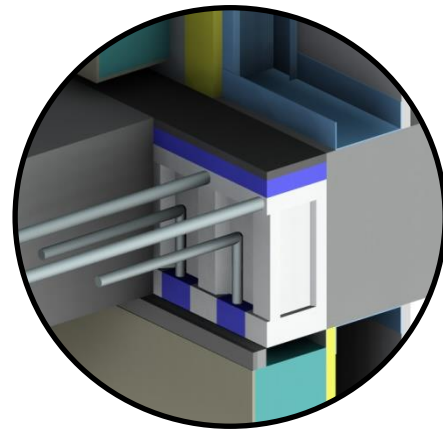
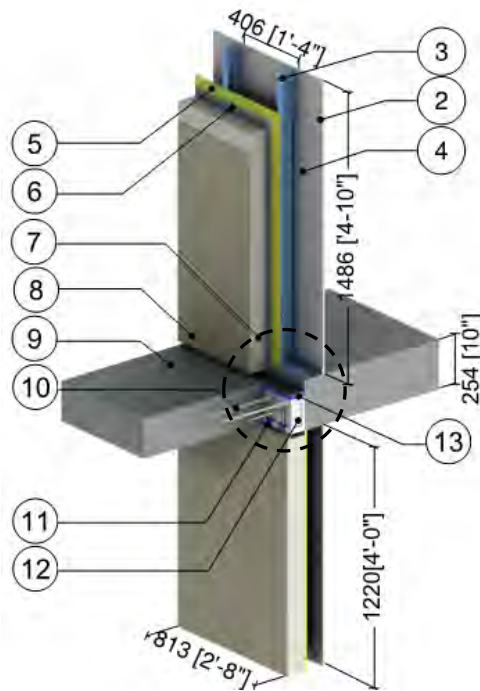

Thermally Broken Slab Detail
(Isokorb CM20)

ID	Component	Thickness Inches (mm)	Conductivity Btu-in / ft ² -hr-°F (W/m K)	Nominal Resistance hr-ft ² -°F/Btu (m ² K/W)	Density lb/ft ³ (kg/m ³)	Specific Heat Btu/lb-°F (J/kg K)
1	Interior Films ¹	-	-	R-0.6 to R-0.9 (0.11 RSI to 0.16 RSI)	-	-
2	Gypsum Board	1/2" (13)	1.1 (0.16)	R-0.5 (0.08 RSI)	50 (800)	0.26 (1090)
3	3 5/8" x 1 5/8" Steel Studs with Top and Bottom Tracks	18 Gauge	430 (62)	-	489 (7830)	0.12 (500)
4	Air in Stud Cavity	3 5/8" (92)	-	R-0.9 (0.16 RSI)	0.075 (1.2)	0.24 (1000)
5	Exterior Sheathing	1/2" (13)	1.1 (0.16)	R-0.5 (0.08 RSI)	50 (800)	0.26 (1090)
6	Weather Resistant Barrier with Adhesive	-	-	-	-	-
7	Insulation Board	4" (100)	0.27 (0.039)	R-14.6 (2.56 RSI)	1.0 (16)	0.35 (1470)
8	Lamina	1/8" (4)	6 (0.9)	R-0.04 (0.01 RSI)	120 (1922)	0.20 (850)
9	Concrete Slab	8" (203)	12.5 (1.8)	-	140 (2250)	0.20 (850)
10	Stainless Steel Rebar	-	118 (17)	-	500 (8000)	0.12 (500)
11	HDPE Plastic Sleeve	-	1.7 (0.25)	-	59 (950)	0.48 (2000)
	UHPC Concrete Mix	-	5.5 (0.80)	-	140 (2250)	0.20 (850)
12	Polystyrene Hard Foam Insulation	3 1/8" (80)	0.217 (0.031)	R-14.7 (2.58 RSI)	66 (1060)	0.35 (1500)
13	Cement Board	1/2" (13)	1.7 (0.25)	-	72 (1150)	0.20 (850)
14	Exterior Film ¹	-	-	R-0.2 (0.03 RSI)	-	-

¹ Value selected from table 1, p. 26.1 of 2009 ASHRAE Handbook – Fundamentals depending on surface orientation

Detail 5.2.10

Exterior and Interior Insulated 3 5/8" x 1 5/8" Steel Stud (16" o.c.) Drained EIFS Wall Assembly with R-12 Batt Insulation in Stud Cavity – Isokorb CM20 Thermally Broken Slab Projection without Concrete Curb

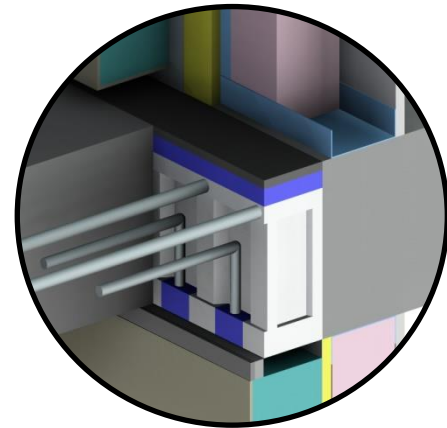
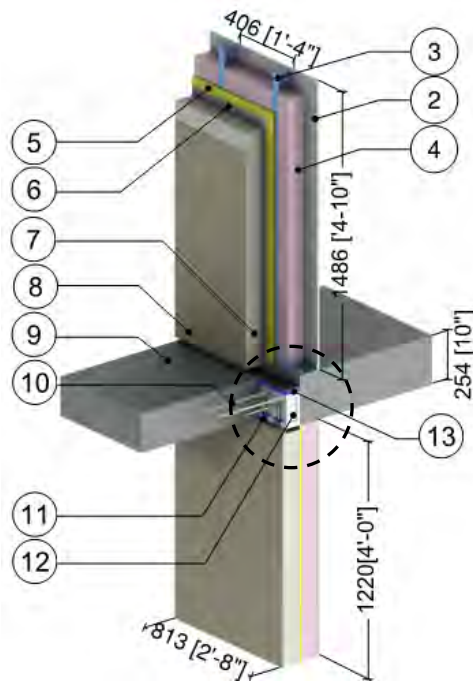

Thermally Broken Slab Detail
(Isokorb CM20)

ID	Component	Thickness Inches (mm)	Conductivity Btu-in / ft ² ·hr·°F (W/m K)	Nominal Resistance hr·ft ² ·°F/Btu (m ² K/W)	Density lb/ft ³ (kg/m ³)	Specific Heat Btu/lb·°F (J/kg K)
1	Interior Films ¹	-	-	R-0.6 to R-0.9 (0.11 RSI to 0.16 RSI)	-	-
2	Gypsum Board	1/2" (13)	1.1 (0.16)	R-0.5 (0.08 RSI)	50 (800)	0.26 (1090)
3	3 5/8" x 1 5/8" Steel Studs with Top and Bottom Tracks	18 Gauge	430 (62)	-	489 (7830)	0.12 (500)
4	Fibreglass Batt Insulation	3 5/8" (92)	0.30 (0.044)	R-12.0 (2.10 RSI)	0.9 (14)	0.17 (710)
5	Exterior Sheathing	1/2" (13)	1.1 (0.16)	R-0.5 (0.08 RSI)	50 (800)	0.26 (1090)
6	Weather Resistive Barrier with Adhesive	-	-	-	-	-
7	Insulation Board	4" (100)	0.27 (0.039)	R-14.6 (2.56 RSI)	1.0 (16)	0.35 (1470)
8	Lamina	1/8" (4)	6 (0.9)	R-0.04 (0.01 RSI)	120 (1922)	0.20 (850)
9	Concrete Slab	8" (203)	12.5 (1.8)	-	140 (2250)	0.20 (850)
10	Stainless Steel Rebar	-	118 (17)	-	500 (8000)	0.12 (500)
11	HDPE Plastic Sleeve	-	1.7 (0.25)	-	59 (950)	0.48 (2000)
	UHPC Concrete Mix	-	5.5 (0.80)	-	140 (2250)	0.20 (850)
12	Polystyrene Hard Foam Insulation	3 1/8" (80)	0.217 (0.031)	R-14.7 (2.58 RSI)	66 (1060)	0.35 (1500)
13	Cement Board	1/2" (13)	1.7 (0.25)	-	72 (1150)	0.20 (850)
14	Exterior Film ¹	-	-	R-0.2 (0.03 RSI)	-	-

¹ Value selected from table 1, p. 26.1 of 2009 ASHRAE Handbook – Fundamentals depending on surface orientation

Detail 5.2.11

Exterior and Interior Insulated 3 5/8" x 1 5/8" Steel Stud (16" o.c.) Wall Assembly with Horizontal Z-girts (24" o.c.) Supporting Metal Cladding and R-12 Batt Insulation in Stud Cavity – Isokorb CM20 Thermally Broken Slab Projection with Uninsulated Curb

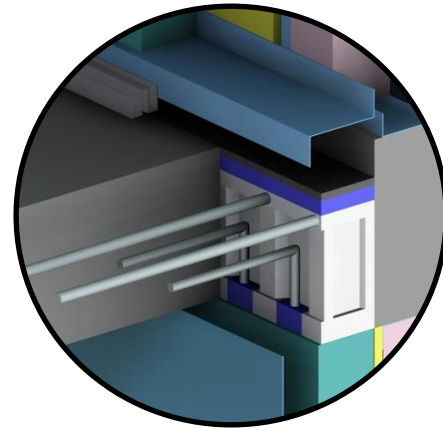
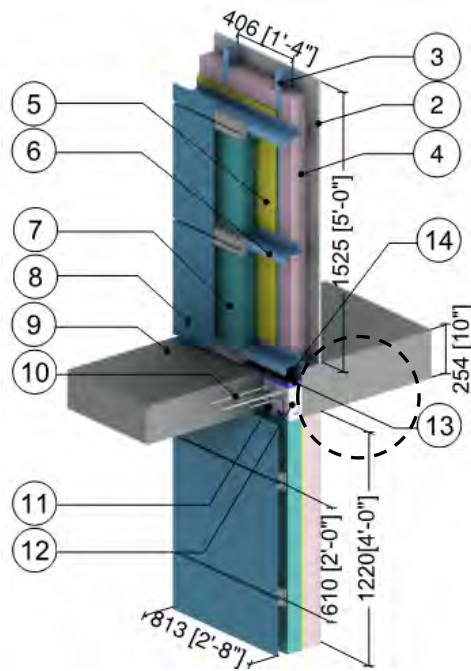

Thermally Broken Slab Detail
(Isokorb CM20)

ID	Component	Thickness Inches (mm)	Conductivity Btu-in / ft ² -hr-°F (W/m K)	Nominal Resistance hr-ft ² -°F/Btu (m ² K/W)	Density lb/ft ³ (kg/m ³)	Specific Heat Btu/lb-°F (J/kg K)
1	Interior Films ¹	-	-	R-0.6 to R-0.9 (0.11 RSI to 0.16 RSI)	-	-
2	Gypsum Board	1/2" (13)	1.1 (0.16)	R-0.5 (0.08 RSI)	50 (800)	0.26 (1090)
3	3 5/8" x 1 5/8" Steel Studs with Top and Bottom Tracks	18 Gauge	430 (62)	-	489 (7830)	0.12 (500)
4	Fibreglass Batt Insulation	3 5/8" (92)	0.30 (0.044)	R-12.0 (2.11 RSI)	0.9 (14)	0.17 (710)
5	Exterior Sheathing	1/2" (13)	1.1 (0.16)	R-0.5 (0.08 RSI)	50 (800)	0.26 (1090)
6	Horizontal Z-girts w/ 1 1/2" Flange	18 Gauge	430 (62)	-	489 (7830)	0.12 (500)
7	Exterior Insulation	3" (76)	-	R-15.0 (2.64 RSI)	1.8 (28)	0.29 (1220)
8	Metal Cladding with 1/2" vented airspace incorporated into exterior heat transfer coefficient					
9	Concrete Slab	8" (203)	12.5 (1.8)	-	140 (2250)	0.20 (850)
10	Stainless Steel Rebar	-	118 (17)	-	500 (8000)	0.12 (500)
11	HDPE Plastic Sleeve	-	1.7 (0.25)	-	59 (950)	0.48 (2000)
	UHPC Concrete Mix	-	5.5 (0.80)	-	140 (2250)	0.20 (850)
12	Polystyrene Hard Foam Insulation	3 1/8" (80)	0.2 (0.031)	R-14.7 (2.58 RSI)	66 (1060)	0.35 (1500)
13	Cement Board	1/2" (13)	1.7 (0.25)	-	72 (1150)	0.20 (850)
14	Exterior Film ¹	-	-	R-0.2 to R-0.7 (0.03 RSI to 0.12 RSI)	-	-

¹ Value selected from table 1, p. 26.1 of 2009 ASHRAE Handbook – Fundamentals depending on surface orientation

Detail 5.2.12

Exterior Insulated 3 5/8" x 1 5/8" Steel Stud (16" o.c.) Wall Assembly with Horizontal Z-girts (24" o.c.) Supporting Metal Cladding – Isokorb CM20 Thermally Broken Slab Projection with Uninsulated Curb

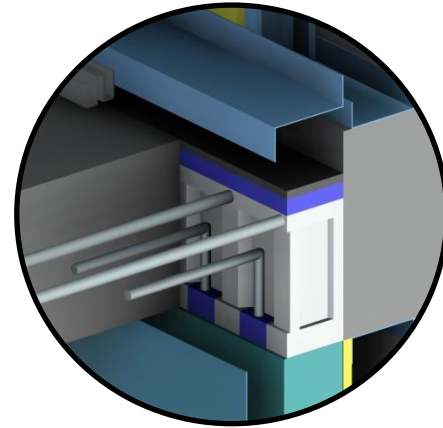
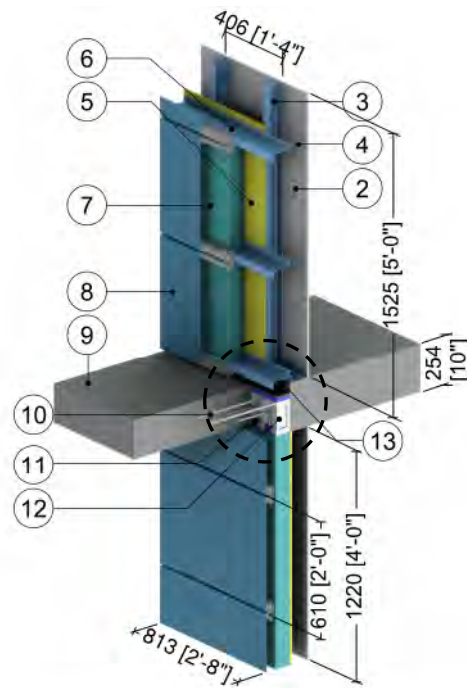

Thermally Broken Slab Detail
(Isokorb CM20)

ID	Component	Thickness Inches (mm)	Conductivity Btu-in / ft ² -hr-°F (W/m K)	Nominal Resistance hr-ft ² -°F/Btu (m ² K/W)	Density lb/ft ³ (kg/m ³)	Specific Heat Btu/lb-°F (J/kg K)
1	Interior Films ¹	-	-	R-0.6 to R-0.9 (0.11 RSI to 0.16 RSI)	-	-
2	Gypsum Board	1/2" (13)	1.1 (0.16)	R-0.5 (0.08 RSI)	50 (800)	0.26 (1090)
3	3 5/8" x 1 5/8" Steel Studs with Top and Bottom Tracks	18 Gauge	430 (62)	-	489 (7830)	0.12 (500)
4	Air in Stud Cavity	3 5/8" (92)	-	R-0.9 (0.16 RSI)	0.075 (1.2)	0.24 (1000)
5	Exterior Sheathing	1/2" (13)	1.1 (0.16)	R-0.5 (0.08 RSI)	50 (800)	0.26 (1090)
6	Horizontal Z-girts w/ 1 1/2" Flange	18 Gauge	430 (62)	-	489 (7830)	0.12 (500)
7	Exterior Insulation	3" (76)	-	R-15.0 (2.64 RSI)	1.8 (28)	0.29 (1220)
8	Metal Cladding with 1/2" vented airspace incorporated into exterior heat transfer coefficient					
9	Concrete Slab	8" (203)	12.5 (1.8)	-	140 (2250)	0.20 (850)
10	Stainless Steel Rebar	-	118 (17)	-	500 (8000)	0.12 (500)
11	HDPE Plastic Sleeve	-	1.7 (0.25)	-	59 (950)	0.48 (2000)
	UHPC Concrete Mix	-	5.5 (0.80)	-	140 (2250)	0.20 (850)
12	Polystyrene Hard Foam Insulation	3" (76)	0.217 (0.031)	R-14.7 (2.58 RSI)	66 (1060)	0.35 (1500)
13	Cement Board	1/2" (13)	1.7 (0.25)	-	72 (1150)	0.20 (850)
14	Exterior Film ¹	-	-	R-0.2 to R-0.7 (0.03 RSI to 0.12 RSI)	-	-

¹ Value selected from table 1, p. 26.1 of 2009 ASHRAE Handbook – Fundamentals depending on surface orientation

Detail 5.2.13

Exterior Insulated 3 5/8" x 1 5/8" Steel Stud (16" o.c.) Wall Assembly with Horizontal Z-girts (24" o.c.) Supporting Metal Cladding – Isokorb CM20 Thermally Broken Slab Projection with Insulated Curb

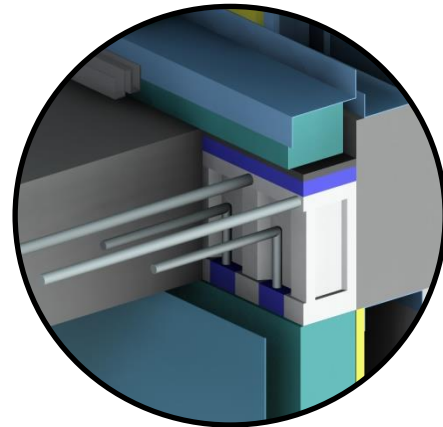
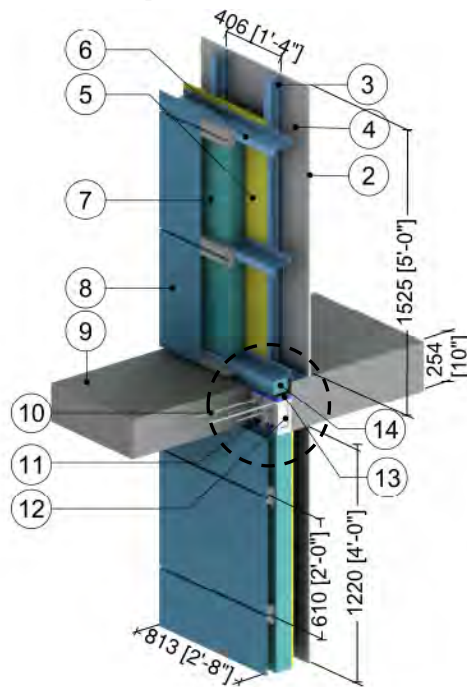

Thermally Broken Slab Detail
(Isokorb CM20)

ID	Component	Thickness Inches (mm)	Conductivity Btu-in / ft ² -hr-°F (W/m K)	Nominal Resistance hr-ft ² -°F/Btu (m ² K/W)	Density lb/ft ³ (kg/m ³)	Specific Heat Btu/lb-°F (J/kg K)
1	Interior Films ¹	-	-	R-0.6 to R-0.9 (0.11 RSI to 0.16 RSI)	-	-
2	Gypsum Board	1/2" (13)	1.1 (0.16)	R-0.5 (0.08 RSI)	50 (800)	0.26 (1090)
3	3 5/8" x 1 5/8" Steel Studs with Top and Bottom Tracks	18 Gauge	430 (62)	-	489 (7830)	0.12 (500)
4	Air in Stud Cavity	3 5/8" (92)	-	R-0.9 (0.16 RSI)	0.075 (1.2)	0.24 (1000)
5	Exterior Sheathing	1/2" (13)	1.1 (0.16)	R-0.5 (0.08 RSI)	50 (800)	0.26 (1090)
6	Horizontal Z-girts w/ 1 1/2" Flange	18 Gauge	430 (62)	-	489 (7830)	0.12 (500)
7	Exterior Insulation	3" (76)	-	R-15.0 (2.64 RSI)	1.8 (28)	0.29 (1220)
8	Metal Cladding with 1/2" vented airspace incorporated into exterior heat transfer coefficient					
9	Concrete Slab	8" (203)	12.5 (1.8)	-	140 (2250)	0.20 (850)
10	Stainless Steel Rebar	-	118 (17)	-	500 (8000)	0.12 (500)
11	HDPE Plastic Sleeve	-	1.7 (0.25)	-	59 (950)	0.48 (2000)
	UHPC Concrete Mix	-	5.5 (0.80)	-	140 (2250)	0.20 (850)
12	Polystyrene Hard Foam Insulation	3 1/8" (80)	0.217 (0.031)	R-14.7 (2.58 RSI)	66 (1060)	0.35 (1500)
13	Cement Board	1/2" (13)	1.7 (0.25)	-	72 (1150)	0.20 (850)
14	Curb Insulation	3" (76)	-	R-15 (2.64 RSI)	1.8 (28)	0.29 (1220)
15	Exterior Film ¹	-	-	R-0.2 to R-0.7 (0.03 RSI to 0.12 RSI)	-	-

¹ Value selected from table 1, p. 26.1 of 2009 ASHRAE Handbook – Fundamentals depending on surface orientation

Detail 5.2.14

Exterior and Interior Insulated 3 5/8" x 1 5/8" Steel Stud (16" o.c.) Wall Assembly with Horizontal Z-girts (24" o.c.) Supporting Metal Cladding and R-12 Batt Insulation in Stud Cavity – Isokorb CM20 Thermally Broken Slab Projection with Insulated Curb

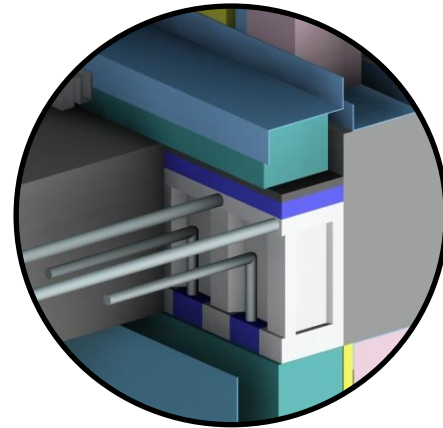
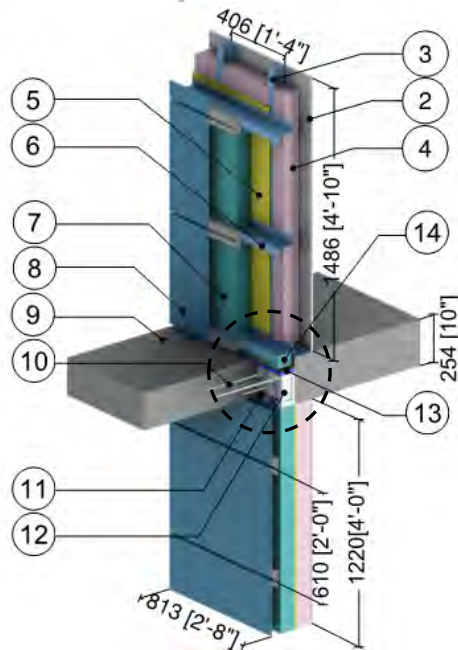

Thermally Broken Slab Detail
(Isokorb CM20)

ID	Component	Thickness Inches (mm)	Conductivity Btu-in / ft ² ·hr·°F (W/m K)	Nominal Resistance hr·ft ² ·°F/Btu (m ² K/W)	Density lb/ft ³ (kg/m ³)	Specific Heat Btu/lb·°F (J/kg K)
1	Interior Films ¹	-	-	R-0.6 to R-0.9 (0.11 RSI to 0.16 RSI)	-	-
2	Gypsum Board	1/2" (13)	1.1 (0.16)	R-0.5 (0.08 RSI)	50 (800)	0.26 (1090)
3	3 5/8" x 1 5/8" Steel Studs with Top and Bottom Tracks	18 Gauge	430 (62)	-	489 (7830)	0.12 (500)
4	Fibreglass Batt Insulation	3 5/8" (92)	0.30 (0.044)	R-12.0 (2.11 RSI)	0.9 (14)	0.17 (710)
5	Exterior Sheathing	1/2" (13)	1.1 (0.16)	R-0.5 (0.08 RSI)	50 (800)	0.26 (1090)
6	Horizontal Z-girts w/ 1 1/2" Flange	18 Gauge	430 (62)	-	489 (7830)	0.12 (500)
7	Exterior Insulation	3" (76)	-	R-15 (2.64 RSI)	1.8 (28)	0.29 (1220)
8	Metal Cladding with 1/2" vented airspace incorporated into exterior heat transfer coefficient					
9	Concrete Slab	8" (203)	12.5 (1.8)	-	140 (2250)	0.20 (850)
10	Stainless Steel Rebar	-	118 (17)	-	500 (8000)	0.12 (500)
11	HDPE Plastic Sleeve	-	1.7 (0.25)	-	59 (950)	0.48 (2000)
	UHPC Concrete Mix	-	5.5 (0.80)	-	140 (2250)	0.20 (850)
12	Polystyrene Hard Foam Insulation	3 1/8" (80)	0.217 (0.031)	R-14.7 (2.58 RSI)	66 (1060)	0.35 (1500)
13	Cement Board	1/2" (13)	1.7 (0.25)	-	72 (1150)	0.20 (850)
14	Curb Insulation	3" (76)	-	R-15 (2.64 RSI)	1.8 (28)	0.29 (1220)
15	Exterior Film ¹	-	-	R-0.2 to R-0.7 (0.03 RSI to 0.12 RSI)	-	-

¹ Value selected from table 1, p. 26.1 of 2009 ASHRAE Handbook – Fundamentals depending on surface orientation

Detail 5.2.15

Exterior Insulated 3 5/8" x 1 5/8" Steel Stud (16" o.c.) Drained EIFS Wall Assembly – Intermediate Floor Intersection

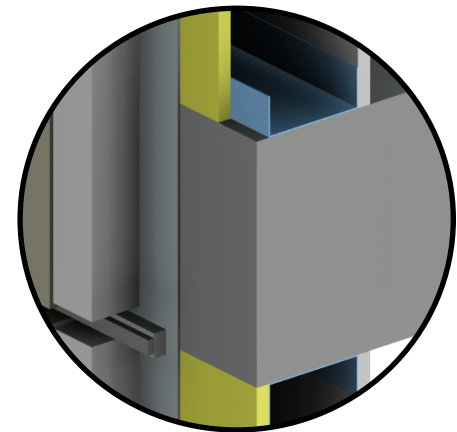
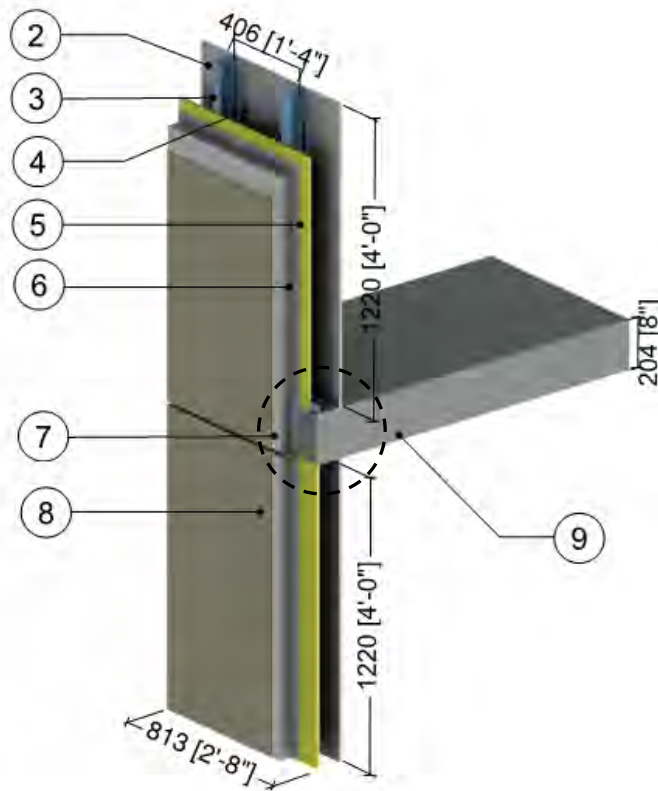

1" (25 mm)
Drained EIFS
at Slab Detail

ID	Component	Thickness Inches (mm)	Conductivity Btu-in / ft ² -hr-°F (W/m K)	Nominal Resistance hr-ft ² -°F/Btu (m ² K/W)	Density lb/ft ³ (kg/m ³)	Specific Heat Btu/lb-°F (J/kg K)
1	Interior Films ¹	-	-	R-0.6 to R-0.9 (0.11 RSI to 0.16 RSI)	-	-
2	Gypsum Board	1/2" (13)	1.1 (0.16)	R-0.5 (0.08 RSI)	50 (800)	0.26 (1090)
3	3 5/8" x 1 5/8" Steel Studs (16" o.c.) with Top and Bottom Tracks	18 Gauge	430 (62)	-	489 (7830)	0.12 (500)
4	Air in Stud Cavity	3 5/8" (92)	-	R-0.9 (0.16 RSI)	0.075 (1.2)	0.24 (1000)
5	Exterior Sheathing	1/2" (13)	1.1 (0.16)	R-0.5 (0.08 RSI)	50 (800)	0.26 (1090)
6	Weather Resistive Barrier with Adhesive	-	-	-	-	-
7	Insulation Board	2" to 4" (50 to 100)	0.27 (0.039)	R-7.5 to R-15 (1.32 RSI to 2.64 RSI)	1 (16)	0.35 (1470)
8	Lamina	1/8" (4)	6 (0.9)	R-0.04 (0.01 RSI)	120 (1922)	0.20 (850)
9	Concrete Slab	8" (203)	12.5 (1.8)	-	140 (2250)	0.20 (850)
10	Exterior Film ¹	-	-	R-0.2 (0.03 RSI)	-	-

¹ Value selected from table 1, p. 26.1 of 2009 ASHRAE Handbook – Fundamentals depending on surface orientation

Detail 5.2.16

Exterior and Interior Insulated 3 5/8" x 1 5/8" Steel Stud (16" o.c.) Drained EIFS Wall Assembly with R-12 Batt Insulation in Stud Cavity – Intermediate Floor Intersection

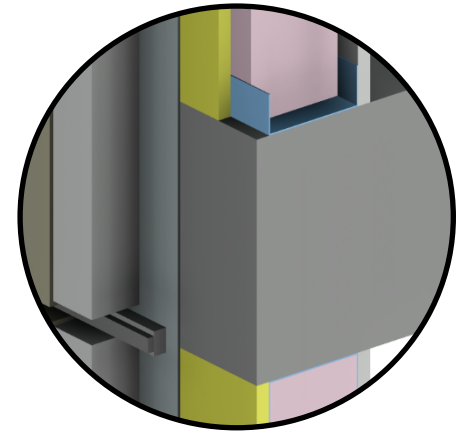
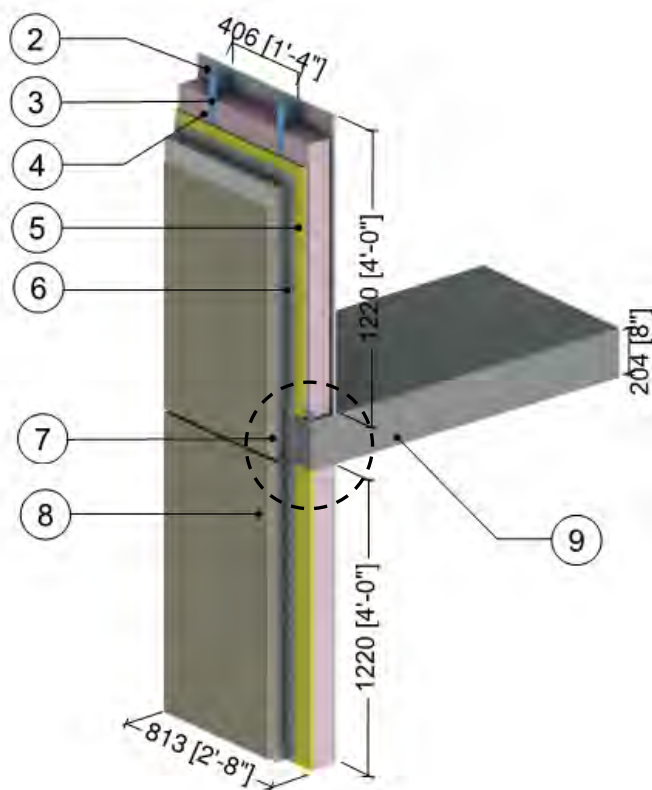

1" (25 mm)
Drained EIFS
at Slab Detail

ID	Component	Thickness Inches (mm)	Conductivity Btu-in / ft ² ·hr·°F (W/m K)	Nominal Resistance hr·ft ² ·°F/Btu (m ² K/W)	Density lb/ft ³ (kg/m ³)	Specific Heat Btu/lb·°F (J/kg K)
1	Interior Films ¹	-	-	R-0.6 to R-0.9 (0.11 RSI to 0.16 RSI)	-	-
2	Gypsum Board	1/2" (13)	1.1 (0.16)	R-0.5 (0.08 RSI)	50 (800)	0.26 (1090)
3	3 5/8" x 3 5/8" Steel Studs (16"o.c.) with Top and Bottom Tracks	18 Gauge	430 (62)	-	489 (7830)	0.12 (500)
4	Fiberglass Batt Insulation	3 5/8" (92)	0.30 (0.044)	R-12.0 (2.1 RSI)	0.9 (1.1)	0.17 (710)
5	Exterior Sheathing	1/2" (13)	1.1 (0.16)	R-0.5 (0.08 RSI)	50 (800)	0.26 (1090)
6	Weather Resistive Barrier with Adhesive	-	-	-	-	-
7	Insulation Board	2" to 4" (50 to 100)	0.27 (0.039)	R-7.5 to R-15 (1.32 RSI to 2.64 RSI)	1 (16)	0.35 (1470)
8	Lamina	1/8" (4)	6 (0.9)	R-0.04 (0.01 RSI)	120 (1922)	0.20 (850)
9	Concrete Slab	8" (203)	12 (1.8)	-	140 (2250)	0.20 (850)
10	Exterior Film ¹	-	-	R-0.2 (0.03 RSI)	-	-

¹ Value selected from table 1, p. 26.1 of 2009 ASHRAE Handbook – Fundamentals depending on surface orientation

Detail 5.2.17

Exterior Insulated 3 5/8" x 1 5/8" Steel Stud (16" o.c.) Wall Assembly with Thermally Broken ISO Clip System Supporting Vertical Sub-girts – Intermediate Concrete Floor Intersection

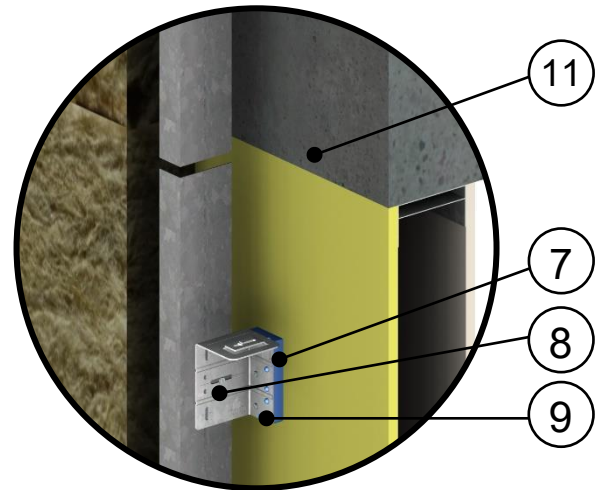
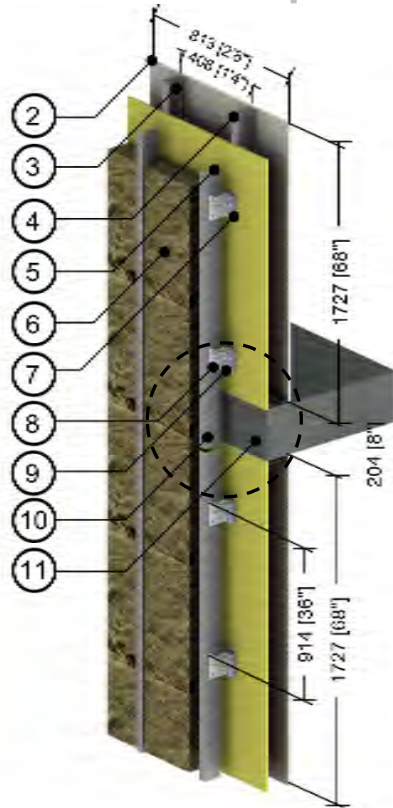

Concrete Floor Intersection

ID	Component	Thickness Inches (mm)	Conductivity Btu-in / ft ² ·hr·°F (W/m K)	Nominal Resistance hr·ft ² ·°F/Btu (m ² K/W)	Density lb/ft ³ (kg/m ³)	Specific Heat Btu/lb·°F (J/kg K)
1	Interior Film ¹	-	-	R-0.6 to R-0.9 (0.11 RSI to 0.16 RSI)	-	-
2	Gypsum Board	1/2" (13)	1.1 (0.16)	R-0.5 (0.08 RSI)	50 (800)	0.26 (1090)
3	Air in Stud Cavity	3 5/8" (92)	-	R-0.9 (0.16 RSI)	0.075 (1.2)	0.24 (1000)
4	3 5/8" x 1 5/8" Steel Studs	18 Gauge	430 (62)	-	489 (7830)	0.12 (500)
5	Exterior Sheathing	1/2" (13)	1.1 (0.16)	R-0.5 (0.08 RSI)	50 (800)	0.26 (1090)
6	Exterior Mineral Wool Insulation	4" to 6" (102 to 152)	0.24 (0.034)	R-16.8 to R-25.2 (2.96 RSI to 4.44 RSI)	4 (64)	0.20 (850)
7	ISO Clip - HDPE Isolator	1/2" (12.7)	3.1 (0.45)	-	-	-
8	ISO Clip - Galvanized Metal	14 gauge	430 (62)	-	489 (7830)	0.12 (500)
9	#14 Steel Fasteners	1/4" (6) Ø	347 (50)	-	489 (7830)	0.12 (500)
10	Vertical Sub-girt	16 gauge	430 (62)	-	489 (7830)	0.12 (500)
11	Concrete Slab	8" (203)	12.5 (1.8)	-	140 (2250)	0.20 (850)
12	Generic Cladding with 1/2" (13mm) vented air space is incorporated into exterior heat transfer coefficient					
13	Exterior Film ¹	-	-	R-0.7 (0.12 RSI)	-	-

¹ Value selected from table 1, p. 26.1 of 2009 ASHRAE Handbook – Fundamentals depending on surface orientation

Detail 5.2.18

Exterior Insulated 3 5/8" x 1 5/8" Steel Stud (16" o.c.) Wall Assembly with Thermally Broken ISO Clip System Supporting Horizontal Sub-girts – Intermediate Concrete Floor Intersection

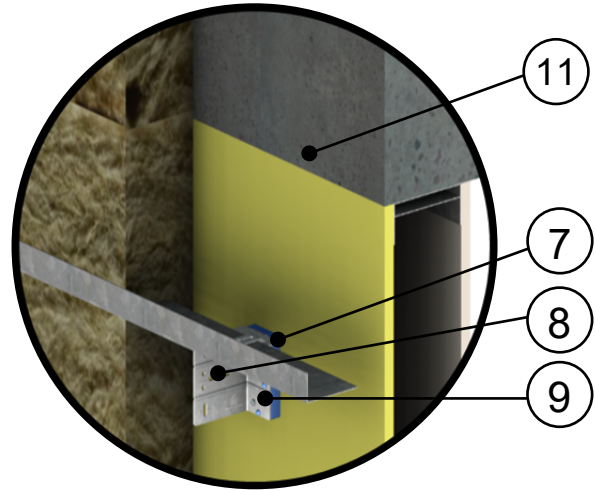
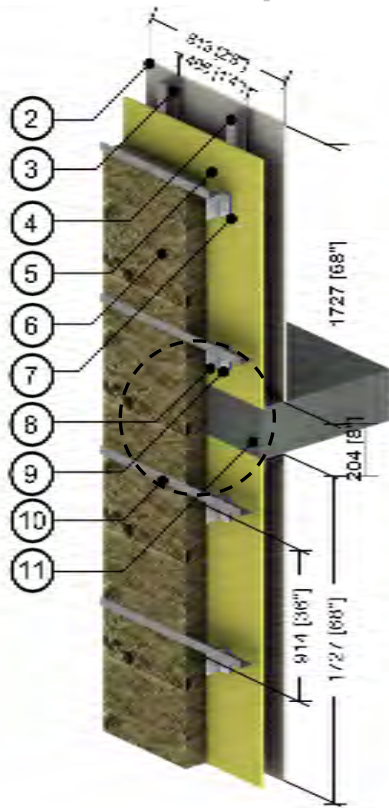

Concrete Floor Intersection

ID	Component	Thickness Inches (mm)	Conductivity Btu-in / ft ² -hr-°F (W/m K)	Nominal Resistance hr-ft ² -°F/Btu (m ² K/W)	Density lb/ft ³ (kg/m ³)	Specific Heat Btu/lb-°F (J/kg K)
1	Interior Film ¹	-	-	R-0.6 to R-0.9 (0.11 RSI to 0.16 RSI)	-	-
2	Gypsum Board	1/2" (13)	1.1 (0.16)	R-0.5 (0.08 RSI)	50 (800)	0.26 (1090)
3	Air in Stud Cavity	3 5/8" (92)	-	R-0.9 (0.16 RSI)	0.075 (1.2)	0.24 (1000)
4	3 5/8" x 1 5/8" Steel Studs	18 Gauge	430 (62)	-	489 (7830)	0.12 (500)
5	Exterior Sheathing	1/2" (13)	1.1 (0.16)	R-0.5 (0.08 RSI)	50 (800)	0.26 (1090)
6	Exterior Mineral Wool Insulation	4" to 6" (102 to 152)	0.24 (0.034)	R-16.8 to R-25.2 (2.96 RSI to 4.44 RSI)	4 (64)	0.20 (850)
7	ISO Clip - HDPE Isolator	1/2" (12.7)	3.1 (0.45)	-	-	-
8	ISO Clip - Galvanized Metal	14 gauge	430 (62)	-	489 (7830)	0.12 (500)
9	#14 Steel Fasteners	1/4" (6) Ø	347 (50)	-	489 (7830)	0.12 (500)
10	Horizontal Sub-girt	16 gauge	430 (62)	-	489 (7830)	0.12 (500)
11	Concrete Slab	8" (203)	12.5 (1.8)	-	140 (2250)	0.20 (850)
12	Generic Cladding with 1/2" (13mm) vented air space is incorporated into exterior heat transfer coefficient					
13	Exterior Film ¹	-	-	R-0.7 (0.12 RSI)	-	-

¹ Value selected from table 1, p. 26.1 of 2009 ASHRAE Handbook – Fundamentals depending on surface orientation

Detail 5.2.19

Exterior and Interior Insulated 3 5/8" x 1 5/8" Steel Stud (16" o.c.) Wall Assembly with Vertical Z-girts (16" o.c.) Supporting Stucco Cladding and R-12 Batt Insulation in Stud Cavity – Steel Framed Floor with Cross Cavity Flashing

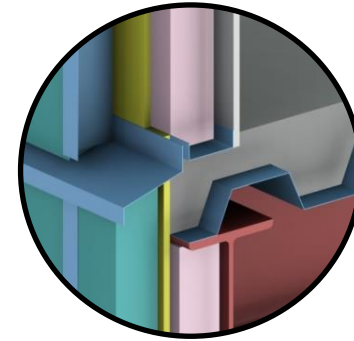
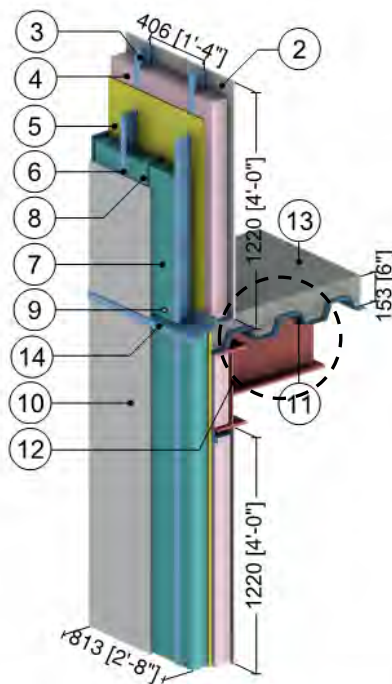

Slab Edge Detail

ID	Component	Thickness Inches (mm)	Conductivity Btu-in / ft ² -hr-°F (W/m K)	Nominal Resistance hr-ft ² -°F/Btu (m ² K/W)	Density lb/ft ³ (kg/m ³)	Specific Heat Btu/lb-°F (J/kg K)
1	Interior Film ¹	-	-	R-0.6 to R-0.9 (0.11 RSI to 0.16 RSI)	-	-
2	Gypsum Board	1/2" (13)	1.1 (0.16)	R-0.5 (0.08 RSI)	50 (800)	0.26 (1090)
3	3 5/8" x 1 5/8" Steel Studs with Top and Bottom Tracks	18 Gauge	430 (62)	-	489 (7830)	0.12 (500)
4	Fiberglass Batt Insulation	3 5/8" (92)	0.30 (0.044)	R-12 (2.1 RSI)	0.9 (14)	0.17 (710)
5	Exterior Sheathing	1/2" (13)	1.1 (0.16)	R-0.5 (0.08 RSI)	50 (800)	0.26 (1090)
6	Vertical Z-girts with 1 1/2" Flange	18 Gauge	430 (62)	-	489 (7830)	0.12 (500)
7	Exterior Insulation	Varies	-	R-10 to R-15 (1.76 RSI to 2.64 RSI)	1.8 (28)	0.29 (1220)
8	Rigid Insulation Bracing	Varies	0.2 (0.029)	-	1.8 (28)	0.29 (1220)
9	Rainscreen Cavity	1/2" (13)	-	R-0.5 (0.09 RSI)	0.075 (1.2)	0.24 (1000)
10	Stucco Cement with Breather Board	1/2" (13)	6.3 (0.9)	R-0.1 (0.01 RSI)	120 (1922)	0.20 (850)
11	Steel Deck	1/16" (1.6)	347 (50)	-	489 (7830)	0.12 (500)
12	Steel Beam (W410)	-	347 (50)	-	489 (7830)	0.12 (500)
13	Concrete Topping	6" (203)	6.3 (0.9)	-	120 (1920)	0.20 (850)
14	Cross Cavity Steel Flashing	18 Gauge	430 (62)	-	489 (7830)	0.12 (500)
15	Exterior Film ¹	-	-	R-0.2 (0.03 RSI)	-	-

¹ Value selected from table 1, p. 26.1 of 2009 ASHRAE Handbook – Fundamentals depending on surface orientation

Detail 5.2.20

Exterior Insulated 3 5/8" x 1 5/8" Steel Stud (16" o.c.) Wall Assembly with Fiberglass Spacer and Through Insulation Fasteners Supporting Cladding – Insulated Intermediate Floor Intersection

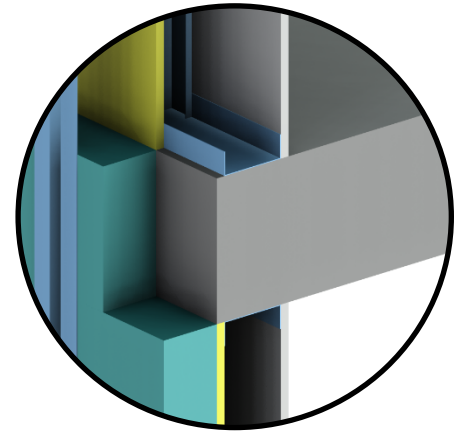
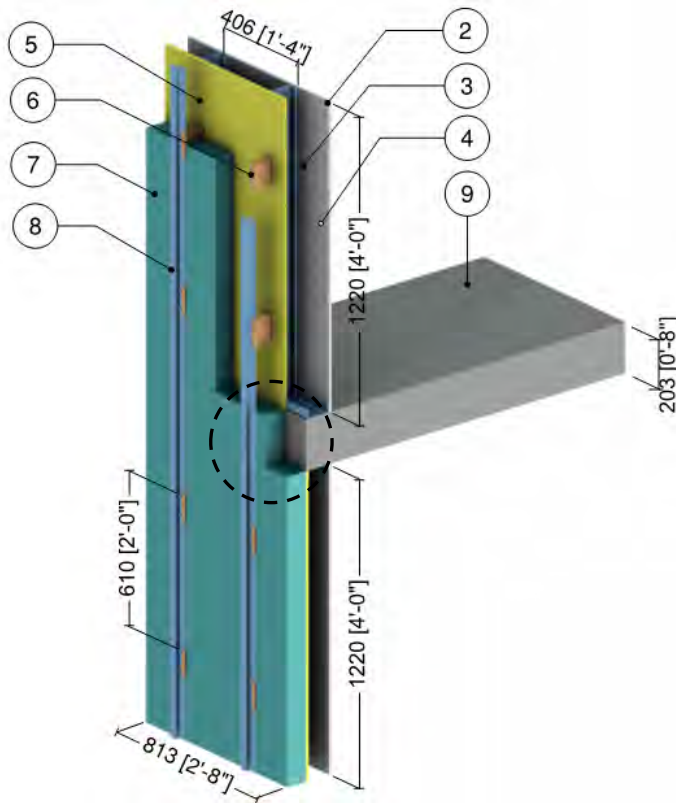

Slab Edge Detail

ID	Component	Thickness Inches (mm)	Conductivity Btu-in / ft ² -hr-°F (W/m K)	Nominal Resistance hr-ft ² -°F/Btu (m ² K/W)	Density lb/ft ³ (kg/m ³)	Specific Heat Btu/lb-°F (J/kg K)
1	Interior Film ¹	-	-	R-0.6 to R-0.9 (0.11 RSI to 0.16 RSI)	-	-
2	Gypsum Board	1/2" (13)	1.1 (0.16)	R-0.5 (0.08 RSI)	50 (800)	0.26 (1090)
3	3 5/8" x 1 5/8" Steel Studs	18 Gauge	430 (62)	-	489 (7830)	0.12 (500)
4	Air in Stud Cavity	3 5/8" (92)	-	R-0.9 (0.16 RSI)	0.075 (1.2)	0.24 (1000)
5	Exterior Sheathing	1/2" (13)	1.1 (0.16)	R-0.5 (0.08 RSI)	50 (800)	0.26 (1090)
6	Fiberglass Spacer	3 1/2" (89)	1.7 (0.299)			
6	#14 Stainless Steel Fasteners	1/4" (6) Ø	118 (17)	-	500 (8000)	0.12 (500)
7	Exterior Insulation	3 1/2" (89)	-	R-15 (2.59 RSI)	1.8 (28)	0.29 (1220)
8	Vertical Steel Z-girts	18 Gauge	430 (62)	-	489 (7830)	0.12 (500)
9	Concrete Slab	8" (203)	12.5 (1.8)	-	140 (2250)	0.20 (850)
10	Cladding with 1/2" vented airspace incorporated into exterior heat transfer coefficient					
11	Exterior Film ¹	-	-	R-0.7 (0.12 RSI)	-	-

¹ Value selected from table 1, p. 26.1 of 2009 ASHRAE Handbook – Fundamentals depending on surface orientation

Detail 5.2.21

Exterior Insulated 3 5/8" x 1 5/8" Steel Stud (16" o.c.) Wall Assembly with Thermally Isolated Aluminum Clip Horizontal Sub-girt System Supporting Cladding – Intermediate Floor Intersection

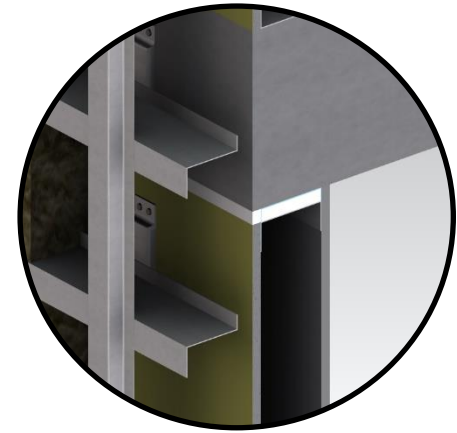
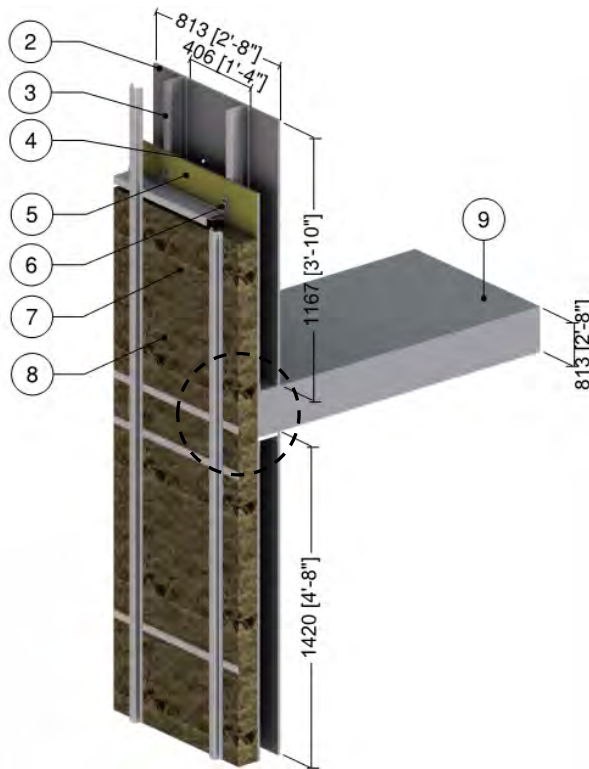

Slab Edge Detail

ID	Component	Thickness Inches (mm)	Conductivity Btu-in / ft ² -hr-°F (W/m K)	Nominal Resistance hr-ft ² -°F/Btu (m ² K/W)	Density lb/ft ³ (kg/m ³)	Specific Heat Btu/lb-°F (J/kg K)
1	Interior Film ¹	-	-	R-0.6 to R-0.9 (0.11 RSI to 0.16 RSI)	-	-
2	Gypsum Board	1/2" (13)	1.1 (0.16)	R-0.5 (0.08 RSI)	50 (800)	0.26 (1090)
3	3 5/8" x 1 5/8" Steel Studs	18 Gauge	430 (62)	-	489 (7830)	0.12 (500)
4	Air in Stud Cavity	3 5/8" (92)	-	R-0.9 (0.16 RSI)	0.075 (1.2)	0.24 (1000)
5	Exterior Sheathing	1/2" (13)	1.1 (0.16)	R-0.5 (0.08 RSI)	50 (800)	0.26 (1090)
6	Engineered Assemblies Aluminum Panel Clip (models T100 T125 150)	1/5" to 3/8" (5 to 10)	1109 (160)			
7	Exterior Insulation	Varies	-	R-16.8 to R-25.2 (2.96 RSI to 4.44 RSI)	1.8 (28)	0.29 (1220)
8	Vertical/Horizontal Steel Girts	18 Gauge	430 (62)	-	489 (7830)	0.12 (500)
9	Concrete Slab	8" (203)	12.5 (1.8)	-	140 (2250)	0.20 (850)
10	Cork/Neoprene pad	1/16" (1.5)	0.329 (0.058)	R-0.15 (0.03 RSI)	-	-
11	Aerogel	3/8" (10)	0.086 (0.015)	R-3.9 (0.68 RSI)		
12	Steel Fasteners	5/16" (8) Ø	347 (50)	-	489 (7830)	0.12 (500)
13	Cladding with 1/2" (13mm) vented airspace incorporated into exterior heat transfer coefficient					
14	Exterior Film ¹	-	-	R-0.7 (0.12 RSI)	-	-

¹ Value selected from table 1, p. 26.1 of 2009 ASHRAE Handbook – Fundamentals depending on surface orientation

Detail 5.2.22

Exterior Insulated 3 5/8" x 1/58" Steel Stud (16"o.c.) Wall Assembly with TAC Fiber Reinforced Plastic Girts Supporting Cladding – Intermediate Floor Intersection

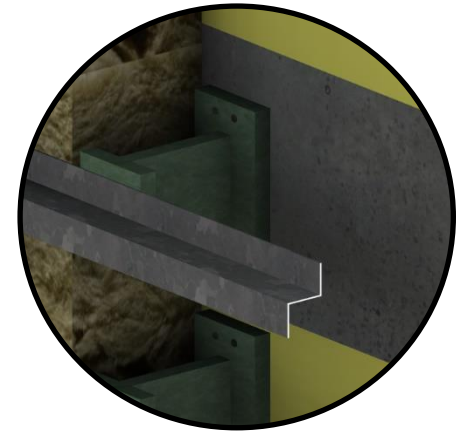
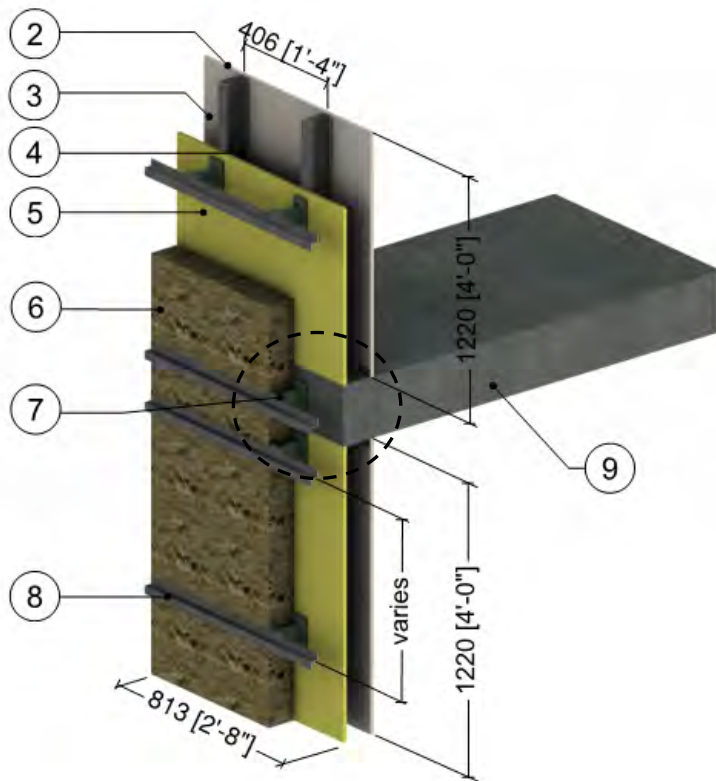

Slab Edge Detail

ID	Component	Thickness Inches (mm)	Conductivity Btu-in / ft ² ·hr·°F (W/m K)	Nominal Resistance hr·ft ² ·°F/Btu (m ² K/W)	Density lb/ft ³ (kg/m ³)	Specific Heat Btu/lb·°F (J/kg K)
1	Interior Films ¹	-	-	R-0.6 to R-0.9 (0.12 RSI to 0.16 RSI)	-	-
2	Gypsum Board	1/2" (13)	1.1 (0.16)	R-0.5 (0.08 RSI)	50 (800)	0.26 (1090)
3	Air in Stud Cavity	3 5/8" (92)	-	R-0.9 (0.16 RSI)	0.075 (1.2)	0.24 (1000)
4	3 5/8" x 1 5/8" Steel Studs (16"o.c.)	18 Gauge	430 (62)	-	489 (7830)	0.12 (500)
5	Exterior Sheathing	1/2" (13)	1.1 (0.16)	R-0.5 (0.08 RSI)	50 (800)	0.26 (1090)
6	Exterior Insulation	Varies	0.24 (0.034)	R-12.6 to R-25.2 (2.22 RSI to 4.40 RSI)	489 (7830)	0.12 (500)
7	Fiber Reinforced Plastic (FRP) Girts	-	2.4 (0.35)	-	-	-
8	Horizontal Girts	18 Gauge	430 (62)	-	489 (7830)	0.12 (500)
9	Concrete Slab	8" (203)	12 (1.8)	-	140 (2250)	0.20 (850)
10	Metal Cladding with 1/2" vented airspace incorporated into exterior heat transfer coefficient					
11	Exterior Film ¹	-	-	R-0.7 (0.12 RSI)	-	-

¹ Value selected from table 1, p. 26.1 of 2009 ASHRAE Handbook – Fundamentals depending on surface orientation

Detail 5.2.23

Exterior Insulated 3 5/8" x 1 5/8" Steel Stud (16" o.c.) Wall Assembly with Thermally Broken Aluminum Clip Rail System (24" o.c.) Supporting Cladding – Intermediate Floor Intersection

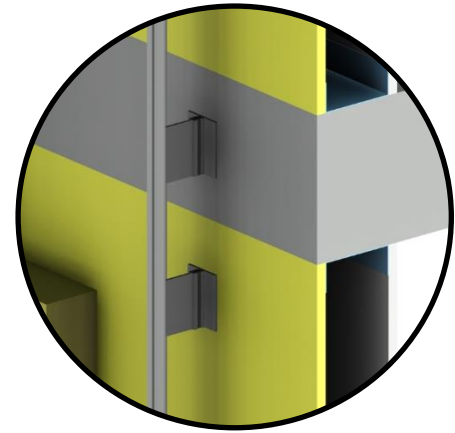
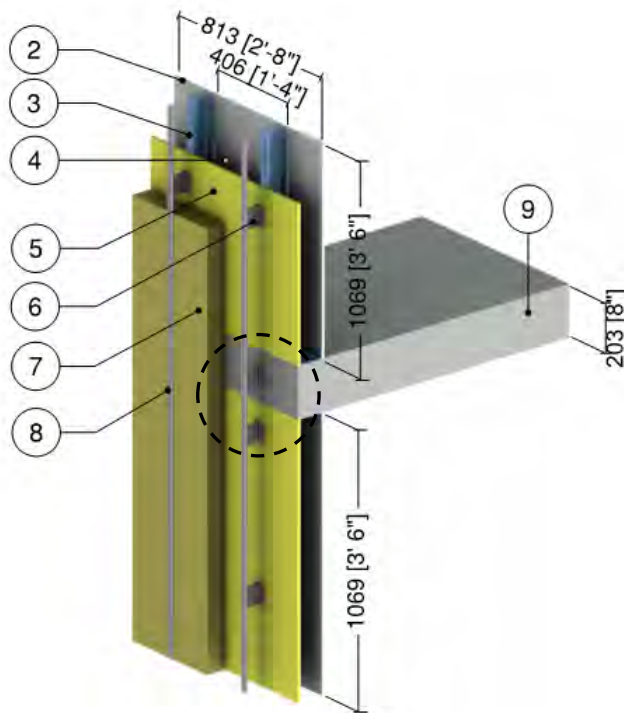

Slab Edge Detail

ID	Component	Thickness Inches (mm)	Conductivity Btu-in / ft ² -hr-°F (W/m K)	Nominal Resistance hr-ft ² -°F/Btu (m ² K/W)	Density lb/ft ³ (kg/m ³)	Specific Heat Btu/lb-°F (J/kg K)
1	Interior Film ¹	-	-	R-0.6 to R-0.9 (0.11 RSI to 0.16 RSI)	-	-
2	Gypsum Board	1/2" (13)	1.1 (0.16)	R-0.5 (0.08 RSI)	50 (800)	0.26 (1090)
3	3 5/8" x 1 5/8" Steel Studs	18 Gauge	430 (62)	-	489 (7830)	0.12 (500)
4	Air in Stud Cavity	3 5/8" (92)	-	R-0.9 (0.16 RSI)	0.075 (1.2)	0.24 (1000)
5	Exterior Sheathing	1/2" (13)	1.1 (0.16)	R-0.5 (0.08 RSI)	50 (800)	0.26 (1090)
6	Longboard Aluminum Panel Clip	1/5" to 3/8" (5 to 10)	1109 (160)	-	-	-
7	Exterior Insulation	Varies	0.24 (0.034)	R-12.6 to R-25.2 (2.22 RSI to 4.44 RSI)	1.8 (28)	0.29 (1220)
8	Vertical Steel Girts	18 Gauge	430 (62)	-	489 (7830)	0.12 (500)
9	Concrete Slab	8" (203)	12.5 (1.8)	-	140 (2250)	0.20 (850)
10	Cladding with 1/2" (13mm) vented airspace incorporated into exterior heat transfer coefficient					
11	Exterior Film ¹	-	-	R-0.7 (0.12 RSI)	-	-

¹ Value selected from table 1, p. 26.1 of 2009 ASHRAE Handbook – Fundamentals depending on surface orientation

Detail 5.2.24

Exterior and Interior Insulated 3 5/8" x 1 5/8" Steel Stud (16" o.c.) Wall Assembly with Horizontal Z-Girts (24" o.c.) Supporting Metal Cladding and R-12 Batt Insulation in Stud Cavity – Structural Steel Framed Floor Intersection

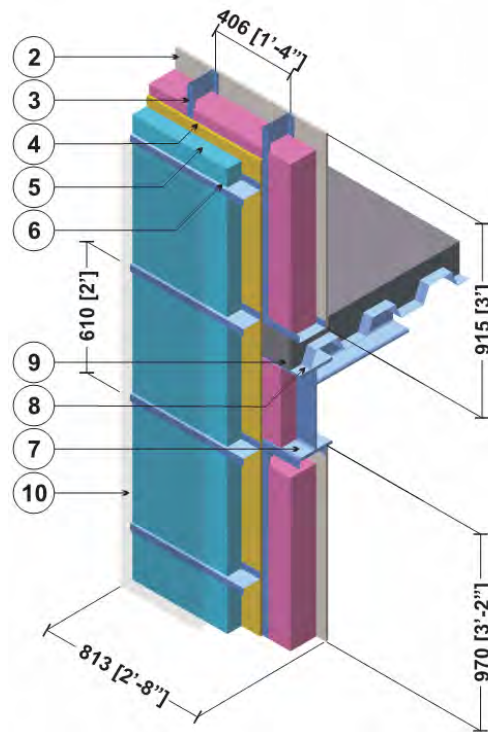

ID	Component	Thickness Inches (mm)	Conductivity Btu-in / ft ² ·hr·°F (W/m K)	Nominal Resistance hr·ft ² ·°F/Btu (m ² K/W)	Density lb/ft ³ (kg/m ³)	Specific Heat Btu/lb·°F (J/kg K)
1	Interior Film ¹	-	-	R-0.6 to R-0.9 (0.11 RSI to 0.16 RSI)	-	-
2	Gypsum Board	1/2" (13)	1.1 (0.16)	R-0.5 (0.08 RSI)	50 (800)	0.26 (1090)
	Fiberglass Batt Insulation	3 5/8" (92)	0.30 (0.044)	R-12 (2.1 RSI)	0.9 (14)	0.17 (710)
3	3 5/8" x 1 5/8" Steel Studs with Top and Bottom Tracks	18 Gauge	430 (62)	-	489 (7830)	0.12 (500)
4	Exterior Sheathing	1/2" (13)	1.1 (0.16)	R-0.5 (0.08 RSI)	50 (800)	0.26 (1090)
5	Exterior Insulation	Varies	-	R-5 to R-25 (0.88 RSI to 4.4 RSI)	1.8 (28)	0.29 (1220)
6	Horizontal Z-girts w/ 1 1/2" Flange	18 Gauge	430 (62)	-	489 (7830)	0.12 (500)
7	Steel Beam (W410)	-	347 (50)	-	489 (7830)	0.12 (500)
8	Steel Deck	1/16" (1.6)	347 (50)	-	489 (7830)	0.12 (500)
9	Concrete Topping	6" (152)	6.3 (0.9)	-	120 (1920)	0.20 (850)
10	Metal cladding with 1/2" (13mm) vented air space is incorporated into exterior heat transfer coefficient					
11	Exterior Film ¹	-	-	R-0.7 (0.12 RSI)	-	-

¹ Value selected from table 1, p. 26.1 of 2009 ASHRAE Handbook – Fundamentals depending on surface orientation

Detail 5.2.25

Interior Insulated 3 5/8" x 1 5/8" Steel Stud (16" o.c.) Wall Assembly with Horizontal Z-Girts (24" o.c.) Supporting Metal Cladding and R-12 Batt Insulation in Stud Cavity – Structural Steel Framed Floor Intersection

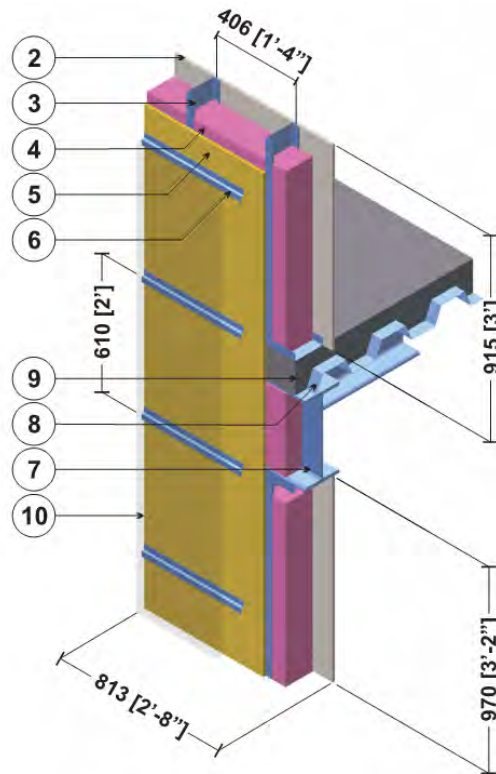

ID	Component	Thickness Inches (mm)	Conductivity Btu-in / ft ² ·hr·°F (W/m K)	Nominal Resistance hr·ft ² ·°F/Btu (m ² K/W)	Density lb/ft ³ (kg/m ³)	Specific Heat Btu/lb·°F (J/kg K)
1	Interior Film ¹	-	-	R-0.6 to R-0.9 (0.11 RSI to 0.16 RSI)	-	-
2	Gypsum Board	1/2" (13)	1.1 (0.16)	R-0.5 (0.08 RSI)	50 (800)	0.26 (1090)
3	3 5/8" x 1 5/8" Steel Studs with Metal Tracks	18 Gauge	430 (62)	-	489 (7830)	0.12 (500)
4	Fiberglass Batt Insulation	3 5/8" (92)	0.30 (0.044)	R-12 (2.1 RSI)	0.9 (14)	0.17 (710)
5	Exterior Sheathing	1/2" (13)	1.1 (0.16)	R-0.5 (0.08 RSI)	50 (800)	0.26 (1090)
6	Horizontal Z-girts w/ 1 1/2" Flange	18 Gauge	430 (62)	-	489 (7830)	0.12 (500)
7	Steel Beam (W410)	-	347 (50)	-	489 (7830)	0.12 (500)
8	Steel Deck	1/16" (1.6)	347 (50)	-	489 (7830)	0.12 (500)
9	Concrete Topping	6" (152)	6.3 (0.9)	-	120 (1920)	0.20 (850)
10	Metal cladding with 1/2" (13mm) vented air space is incorporated into exterior heat transfer coefficient					
11	Exterior Film ¹	-	-	R-0.7 (0.12 RSI)	-	-

¹ Value selected from table 1, p. 26.1 of 2009 ASHRAE Handbook – Fundamentals depending on surface orientation

Detail 5.2.26

Exterior and Interior Insulated Wall Assembly with Shelf Angle & Brick Ties Supporting Brick Veneer and R-12 Batt Insulation in Stud Cavity – Intermediate Floor Intersection

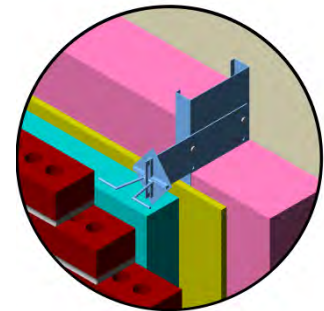
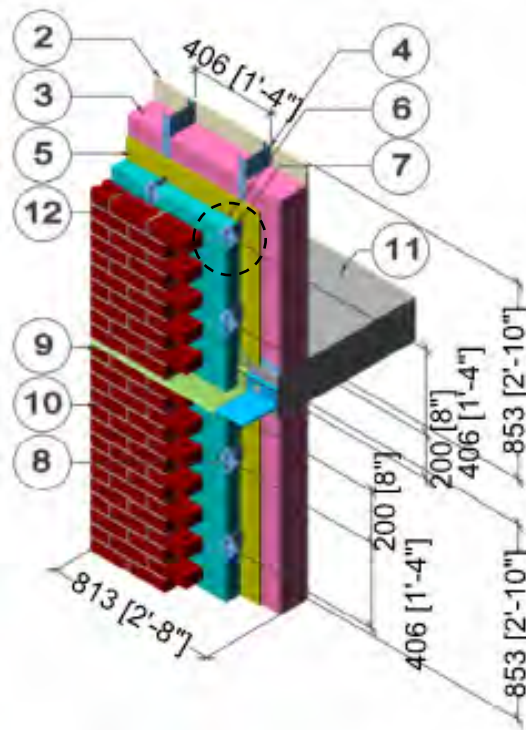

Brick Tie Detail

ID	Component	Thickness Inches (mm)	Conductivity Btu-in / ft ² ·hr·°F (W/m K)	Nominal Resistance hr·ft ² ·°F/Btu (m ² K/W)	Density lb/ft ³ (kg/m ³)	Specific Heat Btu/lb·°F (J/kg K)
1	Interior Film ¹	-	-	R-0.6 to R-0.9 (0.11 RSI to 0.16 RSI)	-	-
2	Gypsum Board	1/2" (13)	1.1 (0.16)	R-0.5 (0.08 RSI)	50 (800)	0.26 (1090)
3	Fiberglass Batt Insulation	3 5/8" (92)	0.30 (0.044)	R-12 (2.1 RSI)	0.9 (14)	0.17 (710)
4	3 5/8" x 1 5/8" Steel Studs with Top and Bottom Tracks	18 Gauge	430 (62)	-	489 (7830)	0.12 (500)
5	Exterior Sheathing	1/2" (13)	1.1 (0.16)	R-0.5 (0.08 RSI)	50 (800)	0.26 (1090)
6	Exterior Insulation	Varies	-	R-5 to R-25 (0.88 RSI to 4.4 RSI)	1.8 (28)	0.29 (1220)
7	Brick Ties	14 Gauge	347 (50)	-	489 (7830)	0.12 (500)
8	Shelf Angle	3/8" (10)	347 (50)	-	489 (7830)	0.12 (500)
9	Flashing	20 Gauge	347 (50)	-	489 (7830)	0.12 (500)
10	Brick Veneer	3 5/8" (92)	5.4 (0.78)	-	120 (1920)	0.19 (720)
11	Concrete Slab	8" (203)	12.5 (1.8)	-	140 (2250)	0.20 (850)
12	Air Gap	1" (25)	-	R-0.9 (0.16 RSI)	0.075 (1.2)	0.24 (1000)
13	Exterior Film ¹	-	-	R-0.2 (0.03 RSI)	-	-

¹ Value selected from table 1, p. 26.1 of 2009 ASHRAE Handbook – Fundamentals depending on surface orientation

Detail 5.2.27

Exterior and Interior Insulated Wall Assembly with Spaced Shelf Angle & Brick Ties Supporting Brick Veneer and R-12 Batt Insulation in Stud Cavity – Intermediate Floor Intersection

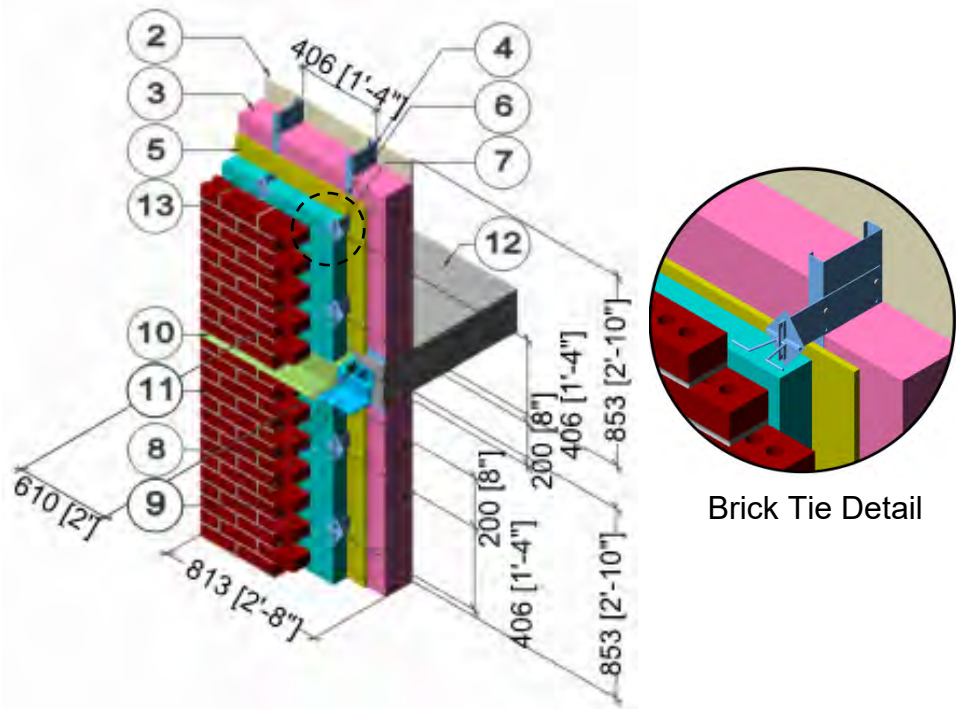

ID	Component	Thickness Inches (mm)	Conductivity Btu-in / ft ² ·hr·°F (W/m K)	Nominal Resistance hr·ft ² ·°F/Btu (m ² K/W)	Density lb/ft ³ (kg/m ³)	Specific Heat Btu/lb·°F (J/kg K)
1	Interior Film ¹	-	-	R-0.6 to R-0.9 (0.11 RSI to 0.16 RSI)	-	-
2	Gypsum Board	1/2" (13)	1.1 (0.16)	R-0.5 (0.08 RSI)	50 (800)	0.26 (1090)
3	Fiberglass Batt Insulation	3 5/8" (92)	0.30 (0.044)	R-12 (2.1 RSI)	0.9 (14)	0.17 (710)
4	3 5/8" x 1 5/8" Steel Studs with Top and Bottom Tracks	18 Gauge	430 (62)	-	489 (7830)	0.12 (500)
5	Exterior Sheathing	1/2" (13)	1.1 (0.16)	R-0.5 (0.08 RSI)	50 (800)	0.26 (1090)
6	Exterior Insulation	Varies	-	R-5 to R-25 (0.88 RSI to 4.4 RSI)	1.8 (28)	0.29 (1220)
7	Brick Ties	14 Gauge	347 (50)	-	489 (7830)	0.12 (500)
8	Exterior Insulation Behind Shelf Angle	Varies	-	R-5 to R-25 (0.88 RSI to 4.4 RSI)	1.8 (28)	0.29 (1220)
9	Spaced Shelf Angle	3/8" (10)	347 (50)	-	489 (7830)	0.12 (500)
10	Flashing	20 Gauge	347 (50)	-	489 (7830)	0.12 (500)
11	Brick Veneer	3 5/8" (92)	5.4 (0.78)	-	120 (1920)	0.19 (720)
12	Concrete Slab	8" (203)	12.5 (1.8)	-	140 (2250)	0.20 (850)
13	Air Gap	1" (25)	-	R-0.9 (0.16 RSI)	0.075 (1.2)	0.24 (1000)
14	Exterior Film ¹	-	-	R-0.2 (0.03 RSI)	-	-

¹ Value selected from table 1, p. 26.1 of 2009 ASHRAE Handbook – Fundamentals depending on surface orientation

Detail 5.2.28

Exterior and Interior Insulated Wall Assembly with Stainless Steel Shelf Angle & Brick Ties Supporting Brick Veneer and R-12 Batt Insulation in Stud Cavity – Intermediate Floor Intersection

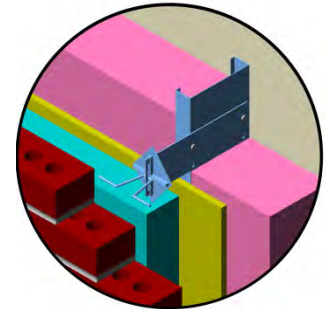
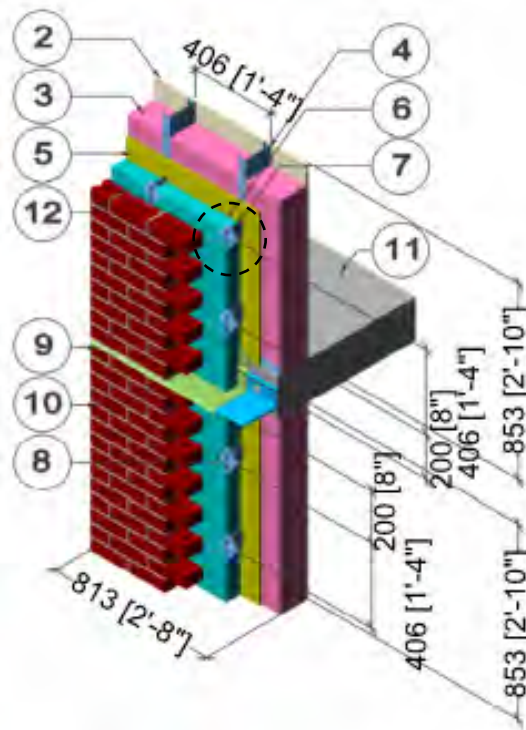

Brick Tie Detail

ID	Component	Thickness Inches (mm)	Conductivity Btu-in / ft ² ·hr·°F (W/m K)	Nominal Resistance hr·ft ² ·°F/Btu (m ² K/W)	Density lb/ft ³ (kg/m ³)	Specific Heat Btu/lb·°F (J/kg K)
1	Interior Film ¹	-	-	R-0.6 to R-0.9 (0.11 RSI to 0.16 RSI)	-	-
2	Gypsum Board	1/2" (13)	1.1 (0.16)	R-0.5 (0.08 RSI)	50 (800)	0.26 (1090)
3	Fiberglass Batt Insulation	3 5/8" (92)	0.30 (0.044)	R-12 (2.1 RSI)	0.9 (14)	0.17 (710)
4	3 5/8" x 1 5/8" Steel Studs with Top and Bottom Tracks	18 Gauge	430 (62)	-	489 (7830)	0.12 (500)
5	Exterior Sheathing	5/8" (16)	1.1 (0.16)	R-0.5 (0.08 RSI)	50 (800)	0.26 (1090)
6	Exterior Insulation	Varies	-	R-5 to R-25 (0.88 RSI to 4.4 RSI)	1.8 (28)	0.29 (1220)
7	Brick Ties	14 Gauge	347 (50)	-	489 (7830)	0.12 (500)
8	Stainless Steel Shelf Angle	3/8" (10)	118 (17)	-	500 (8000)	0.12 (500)
9	Flashing	20 Gauge	347 (50)	-	489 (7830)	0.12 (500)
10	Brick Veneer	3 5/8" (92)	5.4 (0.78)	-	120 (1920)	0.19 (720)
11	Concrete Slab	8" (203)	12.5 (1.8)	-	140 (2250)	0.20 (850)
12	Air Gap	1" (25)	-	R-0.9 (0.16 RSI)	0.075 (1.2)	0.24 (1000)
13	Exterior Film ¹	-	-	R-0.2 (0.03 RSI)	-	-

¹ Value selected from table 1, p. 26.1 of 2009 ASHRAE Handbook – Fundamentals depending on surface orientation

Detail 5.2.29

Exterior and Interior Insulated Wall Assembly with Thermally Broken Steel Shelf Angle & Brick Ties Supporting Brick Veneer and R-12 Batt Insulation in Stud Cavity – Slab Intersection

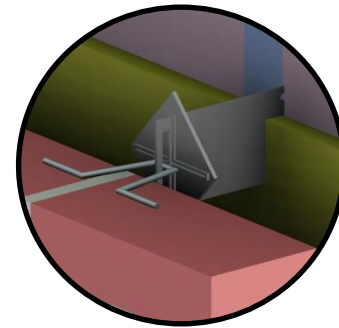
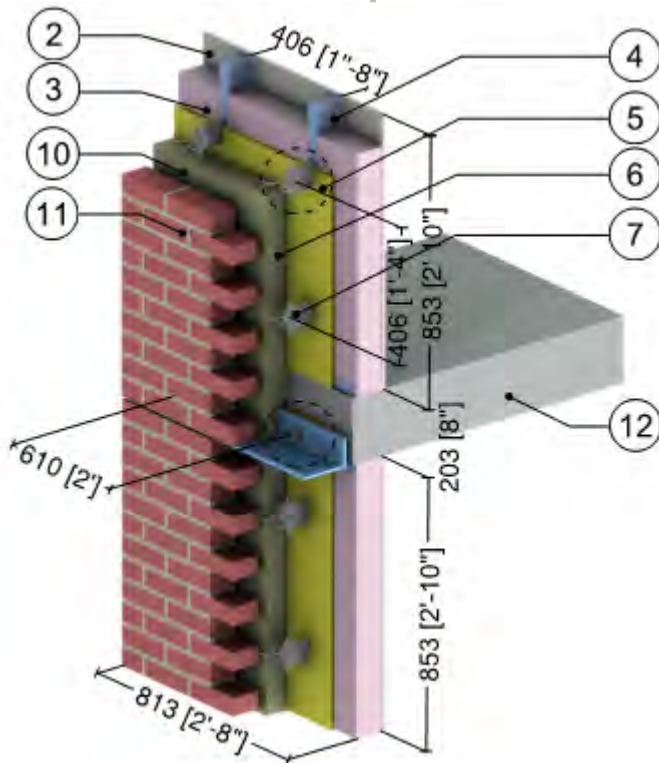

Brick Tie Detail

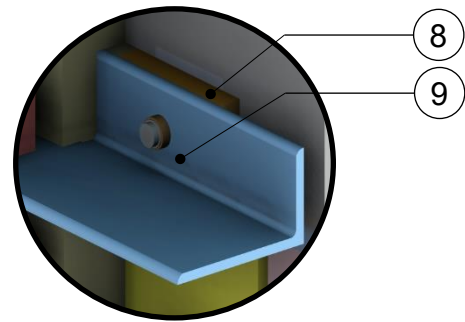

Shelf Angle Detail

ID	Component	Thickness Inches (mm)	Conductivity Btu-in / ft ² ·hr·°F (W/m K)	Nominal Resistance hr·ft ² ·°F/Btu (m ² K/W)	Density lb/ft ³ (kg/m ³)	Specific Heat Btu/lb·°F (J/kg K)
1	Interior Film ¹	-	-	R-0.6 to R-0.9 (0.11 RSI to 0.16 RSI)	-	-
2	Gypsum Board	1/2" (13)	1.1 (0.16)	R-0.5 (0.08 RSI)	50 (800)	0.26 (1090)
3	Fiberglass Batt Insulation	3 5/8" (92)	0.30 (0.044)	R-12 (2.1 RSI)	0.9 (14)	0.17 (710)
4	3 5/8" x 1 5/8" Steel Studs with Top and Bottom Tracks	18 Gauge	430 (62)	-	489 (7830)	0.12 (500)
5	Exterior Sheathing	1/2" (13)	1.1 (0.16)	R-0.5 (0.08 RSI)	50 (800)	0.26 (1090)
6	Exterior Insulation	-	-	R-15 (2.64 RSI)	1.8 (28)	0.29 (1220)
7	Brick Ties	14 Gauge	347 (50)	-	489 (7830)	0.12 (500)
8	Armatherm FRR Thermal Break	1" (25)	1.4 (0.20)	-	85 (5.3)	-
9	Steel Shelf Angle and Bolts	3/8" (10)	347 (50)	-	489 (7830)	0.12 (500)
10	Air Gap ²	1" (25)	-	R-0.9 (0.16 RSI)	0.075 (1.2)	0.24 (1000)
11	Brick Veneer	3 5/8" (92)	5.4 (0.78)	-	120 (1920)	0.19 (720)
12	Concrete Slab	8" (203)	12.5 (1.8)	-	140 (2250)	0.20 (850)
13	Exterior Film ¹	-	-	R-0.2 (0.03 RSI)	-	-

¹ Value selected from table 1, p. 26.1 of 2009 ASHRAE Handbook – Fundamentals depending on surface orientation

² The thermal conductivity of air spaces was found using ISO 100077-2

Detail 5.2.30

Exterior Insulated 3 5/8" x 1 5/8" Steel Stud Wall Assembly with Horizontal Z-girts Supporting Metal Cladding – Armatherm 500 Thermally Broken Slab Projection with Insulated Curb

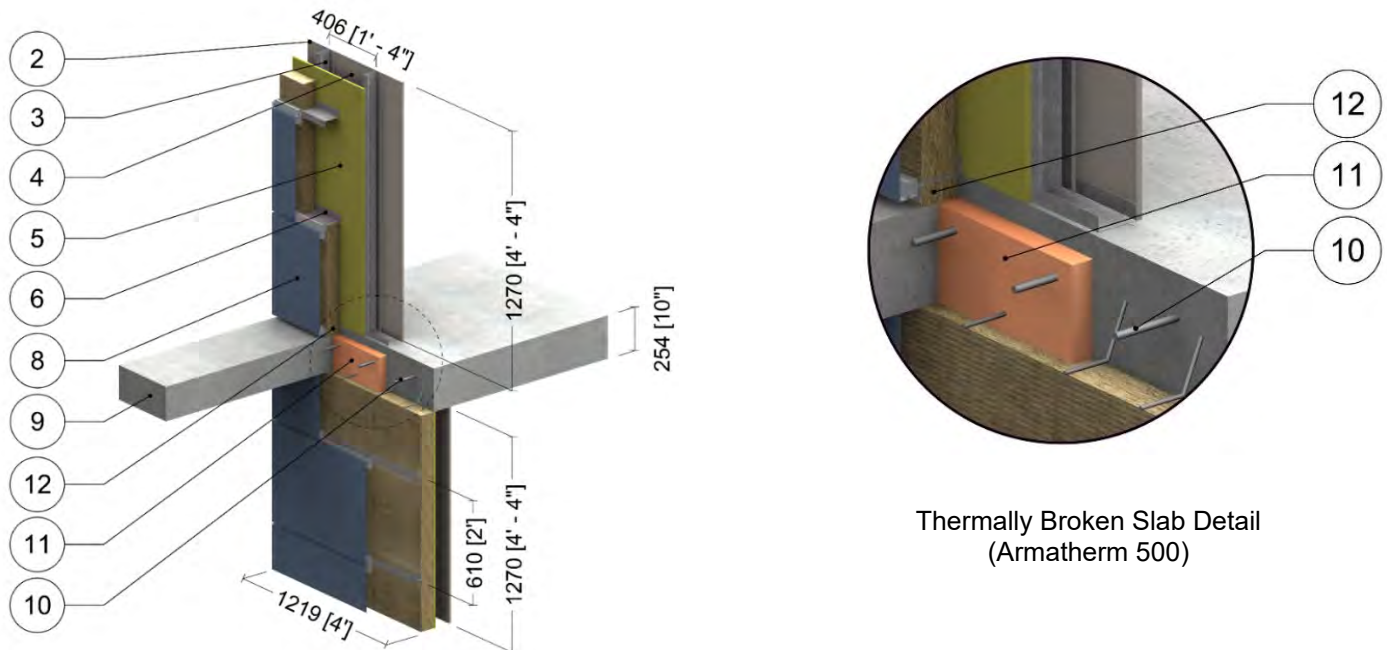

Thermally Broken Slab Detail
(Armatherm 500)

ID	Component	Thickness Inches (mm)	Conductivity Btu-in / ft ² ·hr·°F (W/m K)	Nominal Resistance hr·ft ² ·°F/Btu (m ² K/W)	Density lb/ft ³ (kg/m ³)	Specific Heat Btu/lb·°F (J/kg K)
1	Interior Film ¹	-	-	R-0.6 to R-0.9 (0.11 RSI to 0.16 RSI)	-	-
2	Gypsum Board	1/2" (13)	1.1 (0.16)	R-0.5 (0.08 RSI)	50 (800)	0.26 (1090)
3	3 5/8" x 1 5/8" Steel Studs with Top and Bottom Tracks	18 Gauge	430 (62)	-	489 (7830)	0.12 (500)
4	Air Cavity	3 5/8" (92)	-	R-0.9 (2.11 RSI)	0.075 (1.2)	0.24 (1000)
5	Exterior Sheathing	1/2" (13)	1.1 (0.16)	R-0.5 (0.08 RSI)	50 (800)	0.26 (1090)
6	Horizontal Z-girts	18 Gauge	430 (62)	-	489 (7830)	0.12 (500)
7	Exterior Mineral Wool Insulation	3 1/2" (89)	-	R-14.7 (2.59 RSI)	1.8 (28)	0.29 (1220)
8	Metal Cladding with 1/2" vented airspace incorporated into exterior heat transfer coefficient					
9	Concrete Slab	10" (254)	12.5 (1.8)	-	140 (2250)	0.20 (850)
10	Carbon Steel Rebar	-	430 (62)	-	489 (7830)	0.12 (500)
	Stainless Steel Rebar	-	118 (17)	-	500 (8000)	0.12 (500)
11	Armatherm 500-280 Thermal Break	2" (51)	0.53 (0.08)	-	-	-
	Armatherm 500-080 Thermal Break	2" (51)	0.26 (0.04)	-	-	-
12	Curb Insulation	3 1/2" (89)	-	R-14.7 (2.59 RSI)	1.8 (28)	0.29 (1220)
13	Exterior Film ¹	-	-	R-0.7 (0.12 RSI)	-	-

¹ Value selected from table 1, p. 26.1 of 2009 ASHRAE Handbook – Fundamentals depending on surface orientation

Detail 5.2.31

Exterior Insulated 3 5/8" x 1 5/8" Steel Stud Wall Assembly with Armatherm Z-girts Supporting Metal Cladding – Armatherm 500-080 Thermally Broken Slab Projection with Insulated Curb

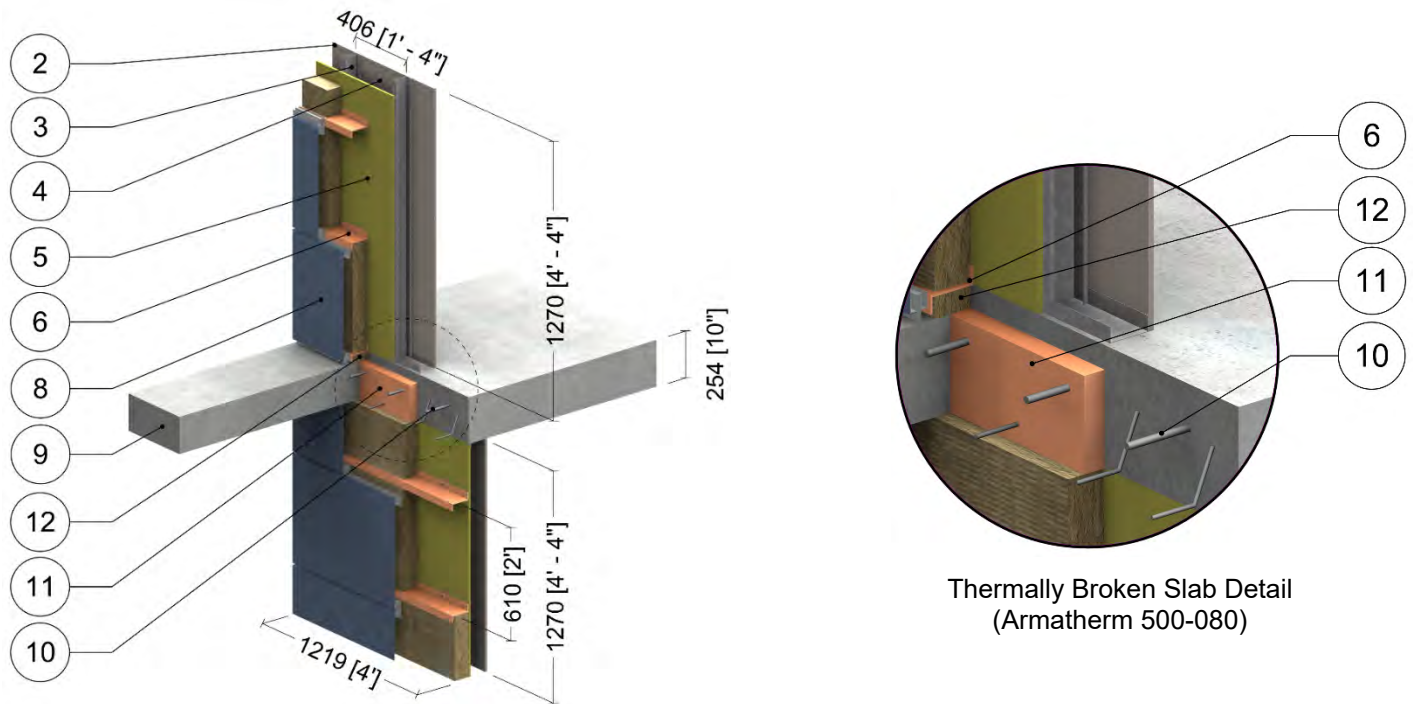

ID	Component	Thickness Inches (mm)	Conductivity Btu-in / ft ² ·hr·°F (W/m K)	Nominal Resistance hr·ft ² ·°F/Btu (m ² K/W)	Density lb/ft ³ (kg/m ³)	Specific Heat Btu/lb·°F (J/kg K)
1	Interior Film ¹	-	-	R-0.6 to R-0.9 (0.11 RSI to 0.16 RSI)	-	-
2	Gypsum Board	1/2" (13)	1.1 (0.16)	R-0.5 (0.08 RSI)	50 (800)	0.26 (1090)
3	3 5/8" x 1 5/8" Steel Studs with Top and Bottom Tracks	18 Gauge	430 (62)	-	489 (7830)	0.12 (500)
4	Air Cavity	3 5/8" (92)	-	R-0.9 (2.11 RSI)	0.075 (1.2)	0.24 (1000)
5	Exterior Sheathing	1/2" (13)	1.1 (0.16)	R-0.5 (0.08 RSI)	50 (800)	0.26 (1090)
6	Armatherm Z-girts (24" o.c.)	0.2 (5)	1.4 (0.2)	-	-	-
7	Exterior Mineral Wool Insulation	3 1/2" (89)	-	R-14.7 (2.59 RSI)	1.8 (28)	0.29 (1220)
8	Metal Cladding with 1/2" vented airspace incorporated into exterior heat transfer coefficient					
9	Concrete Slab	10" (254)	12.5 (1.8)	-	140 (2250)	0.20 (850)
10	Stainless Steel Rebar	-	118 (17)	-	500 (8000)	0.12 (500)
11	Armatherm 500-080 Thermal Break	2" (51)	0.26 (0.04)	-	-	-
12	Curb Insulation	3 1/2" (89)	-	R-14.7 (2.59 RSI)	1.8 (28)	0.29 (1220)
13	Exterior Film ¹	-	-	R-0.7 (0.12 RSI)	-	-

¹ Value selected from table 1, p. 26.1 of 2009 ASHRAE Handbook – Fundamentals depending on surface orientation

Detail 5.2.32

Exterior and Interior Insulated 3 5/8" x 1 5/8" Steel Stud (16" o.c.) Wall Assembly with Nvelope – Eko Thermobacket and NV1 Clip System Supporting Cladding and R-13 Batt Insulation in Stud Cavity – Intermediate Floor Intersection

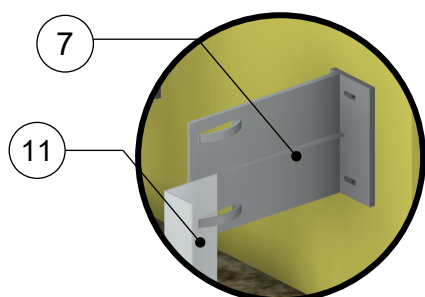
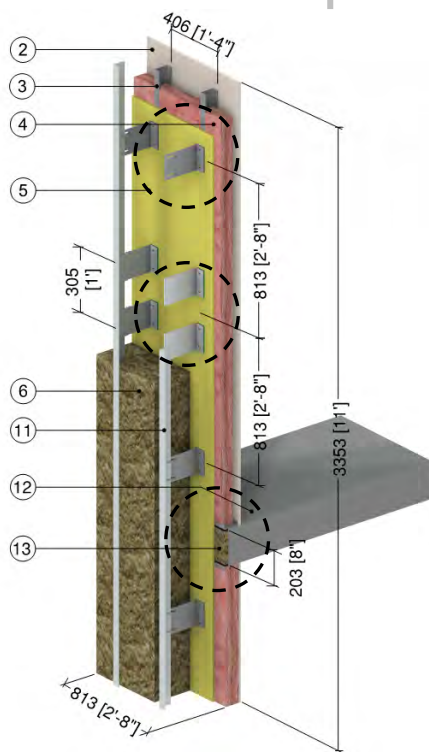

Eko Thermobacket Clip

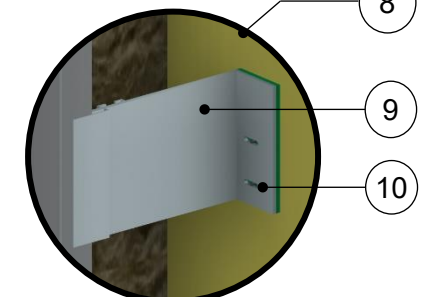

NV1 Clip

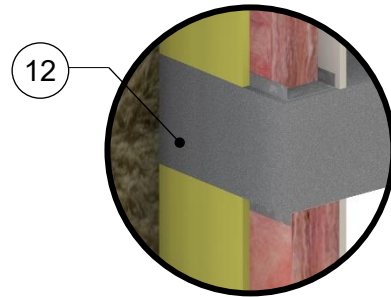

Uninsulated Floor Intersection

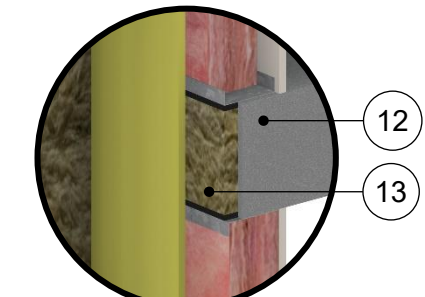

Insulated Floor Intersection

ID	Component	Thickness Inches (mm)	Conductivity Btu-in / ft ² ·hr·°F (W/m K)	Nominal Resistance hr·ft ² ·°F/Btu (m ² K/W)	Density lb/ft ³ (kg/m ³)	Specific Heat Btu/lb·°F (J/kg K)
1	Interior Film ¹	-	-	R-0.7 (0.12 RSI)	-	-
2	Gypsum Board	1/2" (13)	1.1 (0.16)	R-0.5 (0.08 RSI)	50 (800)	0.26 (1090)
3	3 5/8" x 1 5/8" Steel Studs	18 Gauge	430 (62)	-	489 (7830)	0.12 (500)
4	Fiberglass Batt Insulation	3 5/8" (92)	0.28 (0.040)	R-13 (2.29 RSI)	0.9 (14)	0.17 (710)
5	Exterior Sheathing	1/2" (13)	1.1 (0.16)	R-0.5 (0.08 RSI)	50 (800)	0.26 (1090)
6	Exterior Mineral Wool Insulation	1.5" to 4" (38 to 102)	0.24 (0.034)	R-6.3 to R-16.8 (1.11 RSI to 2.96 RSI)	4 (64)	0.20 (850)
7	Nvelope Eko Thermobacket (Polymer Composite)	-	4.86 (0.70)	-	-	-
8	Nvelope Clip Isolator	0.2" (5)	0.82 (0.117)	-	-	-
9	Nvelope Clip Extrusion – Aluminum 6005A alloy	Varies	1340 (193)	-	-	-
10	#14 Stainless Steel Fastener	1/4" (6) ∅	118 (17)	-	-	-
11	Vertical Aluminum Sub-girt	0.09" (2.2)	1340 (193)	-	-	-
12	Concrete Floor Slab	8" (203)	12.5 (1.8)	-	140 (2250)	0.20 (850)
13	Insulation at Floor Slab	1" (25)	0.24 (0.034)	-	4 (64)	0.20 (850)
14	Generic Cladding with 1" (25mm) vented air space is incorporated into exterior heat transfer coefficient					
15	Exterior Film ¹	-	-	R-0.2 (0.03 RSI)	-	-

¹ Value selected from table 1, p. 26.1 of 2009 ASHRAE Handbook – Fundamentals depending on surface orientation

Detail 5.2.33

Exterior Insulated 3 5/8" x 1 5/8" Steel Stud (16" o.c.) Wall Assembly with FERO Slotted Rap Ties (24" o.c.) and FERO FAST Thermal Bracket (48" o.c.) Supporting Brick Veneer – Intermediate Floor Intersection

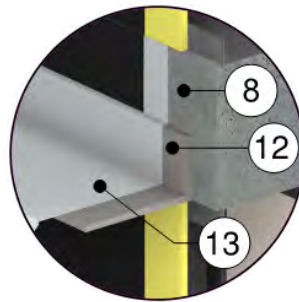
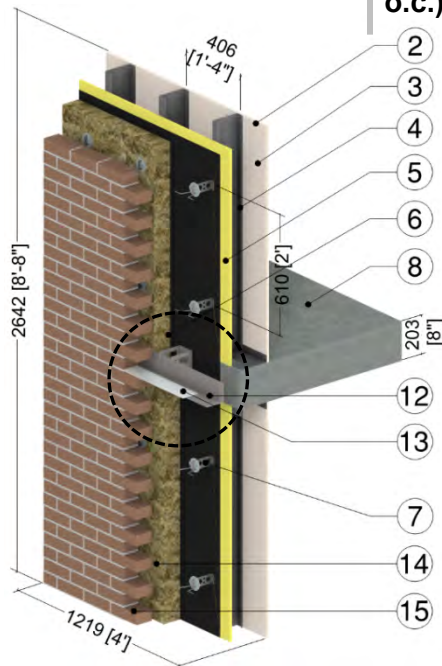

Direct Anchor Shelf Angle



FERO FAST Thermal Bracket System



FERO FAST Thermal Bracket System with Aerogel Coating

ID	Component	Thickness Inches (mm)	Conductivity Btu-in / ft ² ·hr·°F (W/m K)	Nominal Resistance hr·ft ² ·°F/Btu (m ² K/W)	Density lb/ft ³ (kg/m ³)	Specific Heat Btu/lb·°F (J/kg K)
1	Interior Film ¹	-	-	R-0.7 (0.12 RSI)	-	-
2	Gypsum Board	1/2" (13)	1.1 (0.16)	R-0.5 (0.08 RSI)	50 (800)	0.26 (1090)
3	Air in Stud Cavity	3 5/8" (92)	-	R-0.9 (0.16 RSI)	0.075 (1.2)	0.24 (1000)
4	3 5/8" x 1 5/8" Steel Studs with Top and Bottom Tracks	20 Gauge	430 (62)	-	489 (7830)	0.12 (500)
5	Exterior Sheathing	1/2" (13)	1.1 (0.16)	R-0.5 (0.08 RSI)	50 (800)	0.26 (1090)
6	Exterior Insulation	4" (102)	varies	R-16.8 (2.96 RSI) to R-24.0 (4.23 RSI)	varies	varies
7	Brick Ties	4" (102)	430 (62)	-	445 (7130)	0.09 (390)
8	Intermediate Concrete Floor	8" (203)	12.5 (1.8)	-	140 (2250)	0.20 (850)
9	FERO FAST Bracket	3/16" (5)	347 (50)	-	489 (7830)	0.12 (500)
10	Anchor Bolt	5/8" (16) Ø	347 (50)	-	489 (7830)	0.12 (500)
11	Aerogel Coating	1/8" (3)	0.24 (0.035)	-	-	-
12	Shelf Angle	3/8" (10)	347 (50)	-	489 (7830)	0.12 (500)
13	Flashing	20 Gauge	430 (62)	-	489 (7830)	0.12 (500)
14	Vented Air Cavity	1" (25)	-	R-0.4 (0.07 RSI)	0.075 (1.2)	0.24 (1000)
15	Brick Veneer	3 5/8" (92)	5.4 (0.78)	-	120 (1920)	0.19 (720)
16	Exterior Film ¹	-	-	R-0.2 (0.03 RSI)	-	-

¹ Value selected from table 1, p. 26.1 of 2009 ASHRAE Handbook – Fundamentals depending on surface orientation

Detail 5.2.34

Owens Corning Exterior Insulated 6" x 1 5/8" Steel Stud (16" o.c.) Wall Assembly with Thermally Isolated Vertical Brackets and Rail System (24" o.c.) Supporting Metal Cladding – Intermediate Floor Intersection

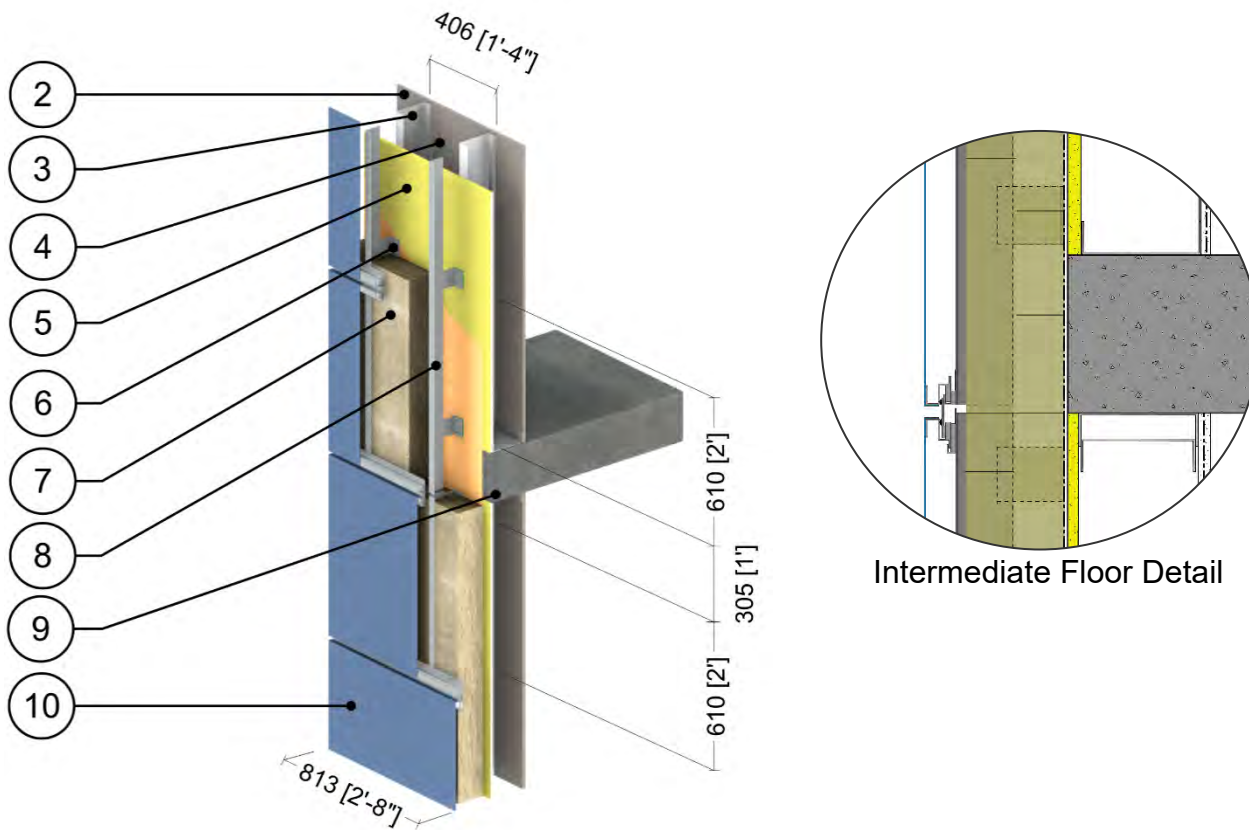

ID	Component	Thickness Inches (mm)	Conductivity Btu-in / ft ² -hr-°F (W/m K)	Nominal Resistance hr-ft ² -°F/Btu (m ² K/W)	Density lb/ft ³ (kg/m ³)	Specific Heat Btu/lb-°F (J/kg K)
1	Interior Film ¹	-	-	R-0.6 to R-0.9 (0.16 to (0.11 RSI)	-	-
2	Gypsum Board	1/2" (13)	1.1 (0.16)	R-0.5 (0.08 RSI)	50 (800)	0.26 (1090)
3	6" x 1 5/8" Steel Studs with Tracks	18 Gauge	430 (62)	-	489 (7830)	0.12 (500)
4	Air in Stud Cavity	6" (152)	-	R-0.9 (0.16 RSI)	0.075 (1.2)	0.24 (1000)
5	Exterior Sheathing	5/8" (16)	1.1 (0.16)	R-0.6 (0.10 RSI)	50 (800)	0.26 (1090)
6	Thermally Isolated Aluminum Bracket	varies	-	-	-	-
7	Thermafiber RainBarrier 45 Mineral Wool Semi Rigid Insulation	varies	0.24 (0.034)	R-8.4 to R-21.0 (1.48 to 3.70 RSI)	4.5 (72)	0.20 (850)
8	Vertical Aluminum L-girt	0.09" (2.2)	1110 (160)	-	171 (2739)	0.22 (900)
9	Concrete Slab	8" (203)	12.5 (1.8)	-	140 (2250)	0.20 (850)
10	Cladding with 1/2" (13mm) vented airspace incorporated into exterior heat transfer coefficient					
11	Exterior Film ¹	-	-	R-0.7 (0.12 RSI)	-	-

¹ Value selected from table 1, p. 26.1 of 2009 ASHRAE Handbook – Fundamentals depending on surface orientation

Detail 5.2.35

Exterior and Interior Insulated 6" x 1 5/8" Steel Stud (16" o.c.) Wall Assembly with Thermally Isolated Vertical Brackets and Rail System (24" o.c.) Supporting Metal Cladding and Owens Corning R-20 Batt in Stud Cavity – Intermediate Floor Intersection

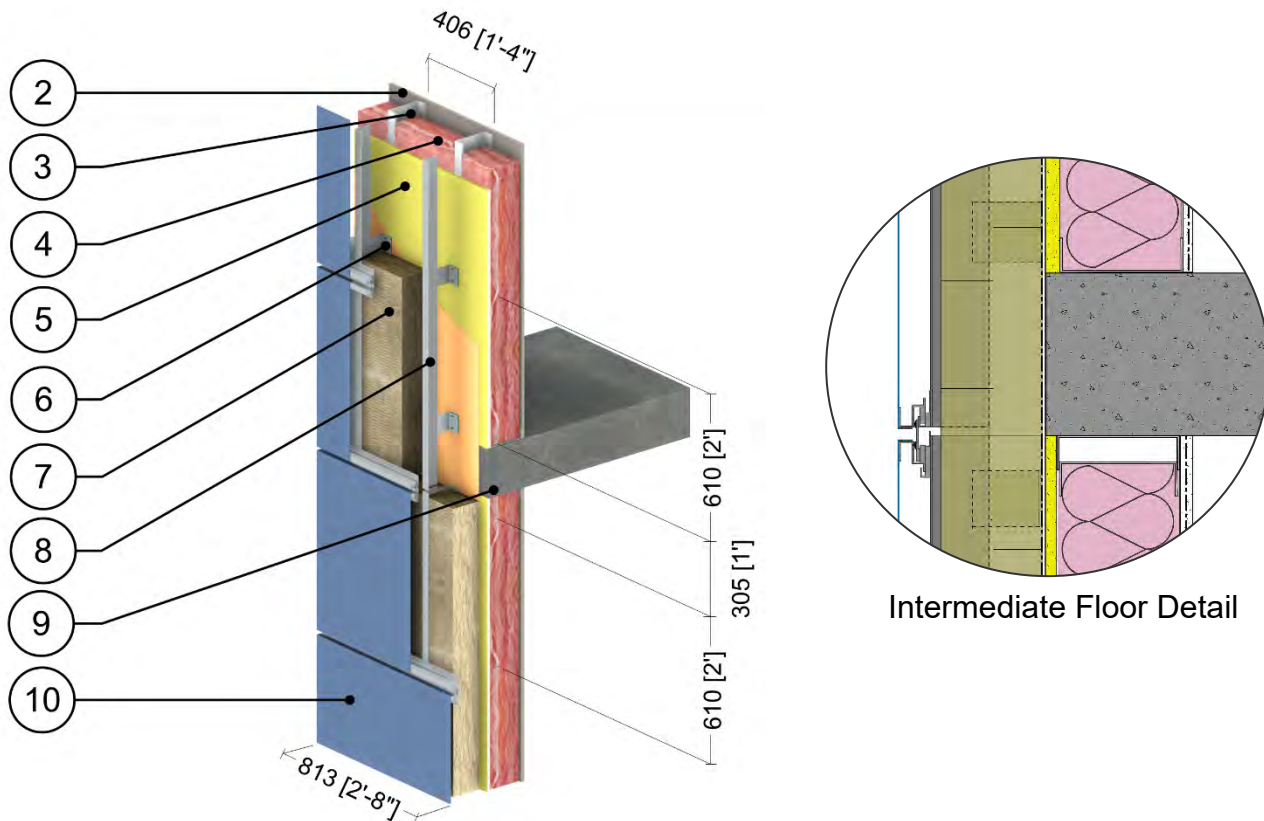

ID	Component	Thickness Inches (mm)	Conductivity Btu-in / ft ² ·hr·°F (W/m K)	Nominal Resistance hr·ft ² ·°F/Btu (m ² K/W)	Density lb/ft ³ (kg/m ³)	Specific Heat Btu/lb·°F (J/kg K)
1	Interior Film ¹	-	-	R-0.6 to R-0.9 (0.16 to (0.11 RSI)	-	-
2	Gypsum Board	1/2" (13)	1.1 (0.16)	R-0.5 (0.08 RSI)	50 (800)	0.26 (1090)
3	6" x 1 5/8" Steel Studs with Tracks	18 Gauge	430 (62)	-	489 (7830)	0.12 (500)
4	Ecotouch Pink Fiberglass Batt	6" (152)	0.30 (0.043)	R-20 (3.52 RSI)	0.55 (8.8)	0.17 (710)
5	Exterior Sheathing	5/8" (16)	1.1 (0.16)	R-0.6 (0.10 RSI)	50 (800)	0.26 (1090)
6	Thermally Isolated Aluminum Bracket	varies	-	-	-	-
7	Thermafiber RainBarrier 45 Mineral Wool Semi Rigid Insulation	varies	0.24 (0.034)	R-8.4 to R-21.0 (1.48 to 3.70 RSI)	4.5 (72)	0.20 (850)
8	Vertical Aluminum L-girt	0.09" (2.2)	1110 (160)	-	171 (2739)	0.22 (900)
9	Concrete Slab	8" (203)	12.5 (1.8)	-	140 (2250)	0.20 (850)
10	Cladding with 1/2" (13mm) vented airspace incorporated into exterior heat transfer coefficient					
11	Exterior Film ¹	-	-	R-0.7 (0.12 RSI)	-	-

¹ Value selected from table 1, p. 26.1 of 2009 ASHRAE Handbook – Fundamentals depending on surface orientation

Detail 5.2.36

Exterior and Interior Insulated 6" x 1 5/8" Steel Stud (16" o.c.) Wall Assembly with Thermally Isolated Vertical Brackets and Rail System (24" o.c.) Supporting Metal Cladding and Owens Corning R-22.5 Batt in Stud Cavity – Intermediate Floor Intersection

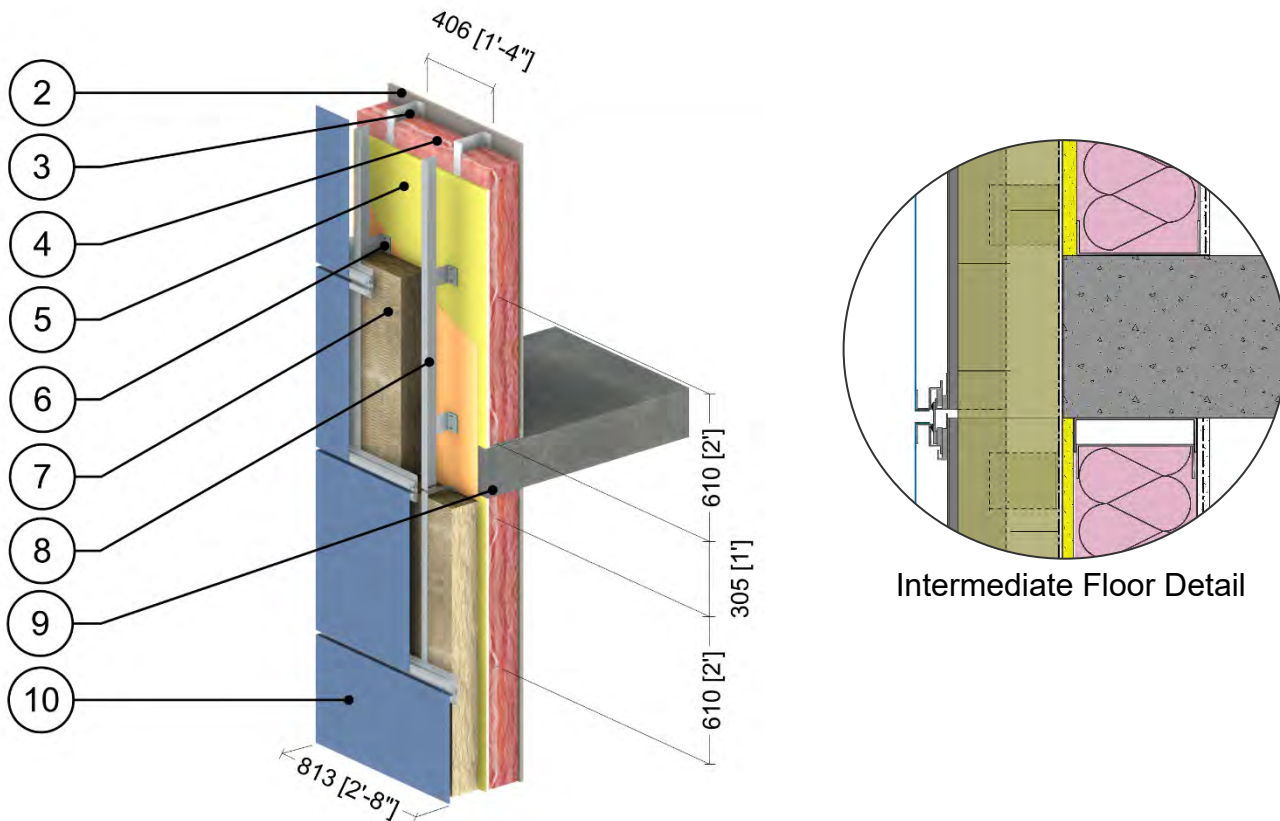

ID	Component	Thickness Inches (mm)	Conductivity Btu-in / ft ² -hr-°F (W/m K)	Nominal Resistance hr-ft ² -°F/Btu (m ² K/W)	Density lb/ft ³ (kg/m ³)	Specific Heat Btu/lb-°F (J/kg K)
1	Interior Film ¹	-	-	R-0.6 to R-0.9 (0.16 to (0.11 RSI)	-	-
2	Gypsum Board	1/2" (13)	1.1 (0.16)	R-0.5 (0.08 RSI)	50 (800)	0.26 (1090)
3	6" x 1 5/8" Steel Studs with Tracks	18 Gauge	430 (62)	-	489 (7830)	0.12 (500)
4	Ecotouch Pink Fiberglass Batt	6" (152)	0.26 (0.038)	R-22.5 (3.96 RSI)	0.99 (15.9)	0.17 (710)
5	Exterior Sheathing	5/8" (16)	1.1 (0.16)	R-0.6 (0.10 RSI)	50 (800)	0.26 (1090)
6	Thermally Isolated Aluminum Bracket	varies	-	-	-	-
7	Thermafiber RainBarrier 45 Mineral Wool Semi Rigid Insulation	varies	0.24 (0.034)	R-8.4 to R-21.0 (1.48 to 3.70 RSI)	4.5 (72)	0.20 (850)
8	Vertical Aluminum L-girt	0.09" (2.2)	1110 (160)	-	171 (2739)	0.22 (900)
9	Concrete Slab	8" (203)	12.5 (1.8)	-	140 (2250)	0.20 (850)
10	Cladding with 1/2" (13mm) vented airspace incorporated into exterior heat transfer coefficient					
11	Exterior Film ¹	-	-	R-0.7 (0.12 RSI)	-	-

¹ Value selected from table 1, p. 26.1 of 2009 ASHRAE Handbook – Fundamentals depending on surface orientation

Detail 5.2.37

Exterior and Interior Insulated 6" x 1 5/8" Steel Stud (16" o.c.) Wall Assembly with Thermally Isolated Vertical Brackets and Rail System (24" o.c.) Supporting Metal Cladding and Owens Corning R-24 Batt in Stud Cavity – Intermediate Floor Intersection

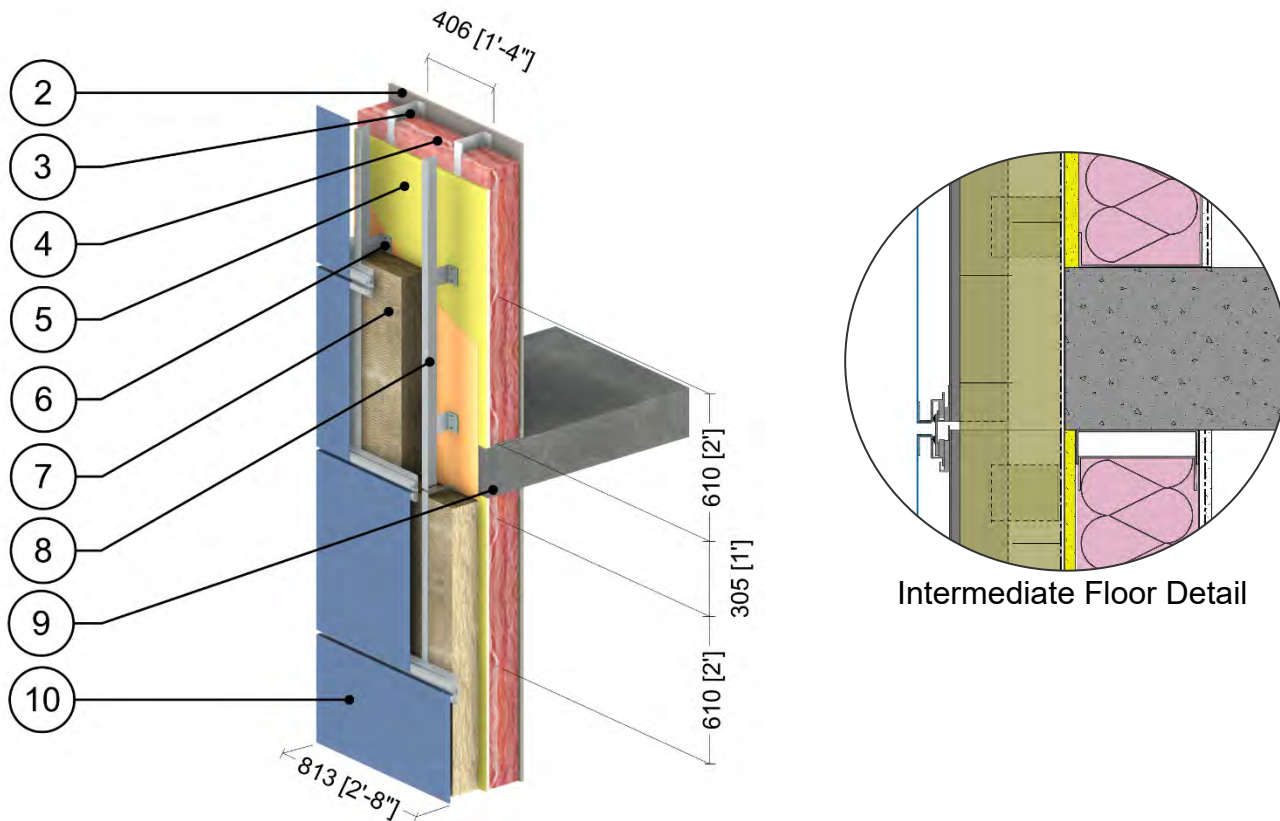

ID	Component	Thickness Inches (mm)	Conductivity Btu-in / ft ² ·hr·°F (W/m K)	Nominal Resistance hr·ft ² ·°F/Btu (m ² K/W)	Density lb/ft ³ (kg/m ³)	Specific Heat Btu/lb·°F (J/kg K)
1	Interior Film ¹	-	-	R-0.6 to R-0.9 (0.16 to (0.11 RSI)	-	-
2	Gypsum Board	1/2" (13)	1.1 (0.16)	R-0.5 (0.08 RSI)	50 (800)	0.26 (1090)
3	6" x 1 5/8" Steel Studs with Tracks	18 Gauge	430 (62)	-	489 (7830)	0.12 (500)
4	Ecotouch Pink Fiberglass Batt	6" (152)	0.25 (0.036)	R-24 (4.23 RSI)	1.42 (22.7)	0.17 (710)
5	Exterior Sheathing	5/8" (16)	1.1 (0.16)	R-0.6 (0.10 RSI)	50 (800)	0.26 (1090)
6	Thermally Isolated Aluminum Bracket	varies	-	-	-	-
7	Thermafiber RainBarrier 45 Mineral Wool Semi Rigid Insulation	varies	0.24 (0.034)	R-8.4 to R-21.0 (1.48 to 3.70 RSI)	4.5 (72)	0.20 (850)
8	Vertical Aluminum L-girt	0.09" (2.2)	1110 (160)	-	171 (2739)	0.22 (900)
9	Concrete Slab	8" (203)	12.5 (1.8)	-	140 (2250)	0.20 (850)
10	Cladding with 1/2" (13mm) vented airspace incorporated into exterior heat transfer coefficient					
11	Exterior Film ¹	-	-	R-0.7 (0.12 RSI)	-	-

¹ Value selected from table 1, p. 26.1 of 2009 ASHRAE Handbook – Fundamentals depending on surface orientation

Detail 5.2.38

Exterior Insulated 6" x 1 5/8" Steel Stud (16" o.c.) Wall Assembly with FRP Vertical Brackets and Rail System Supporting Metal Cladding – Intermediate Floor Intersection

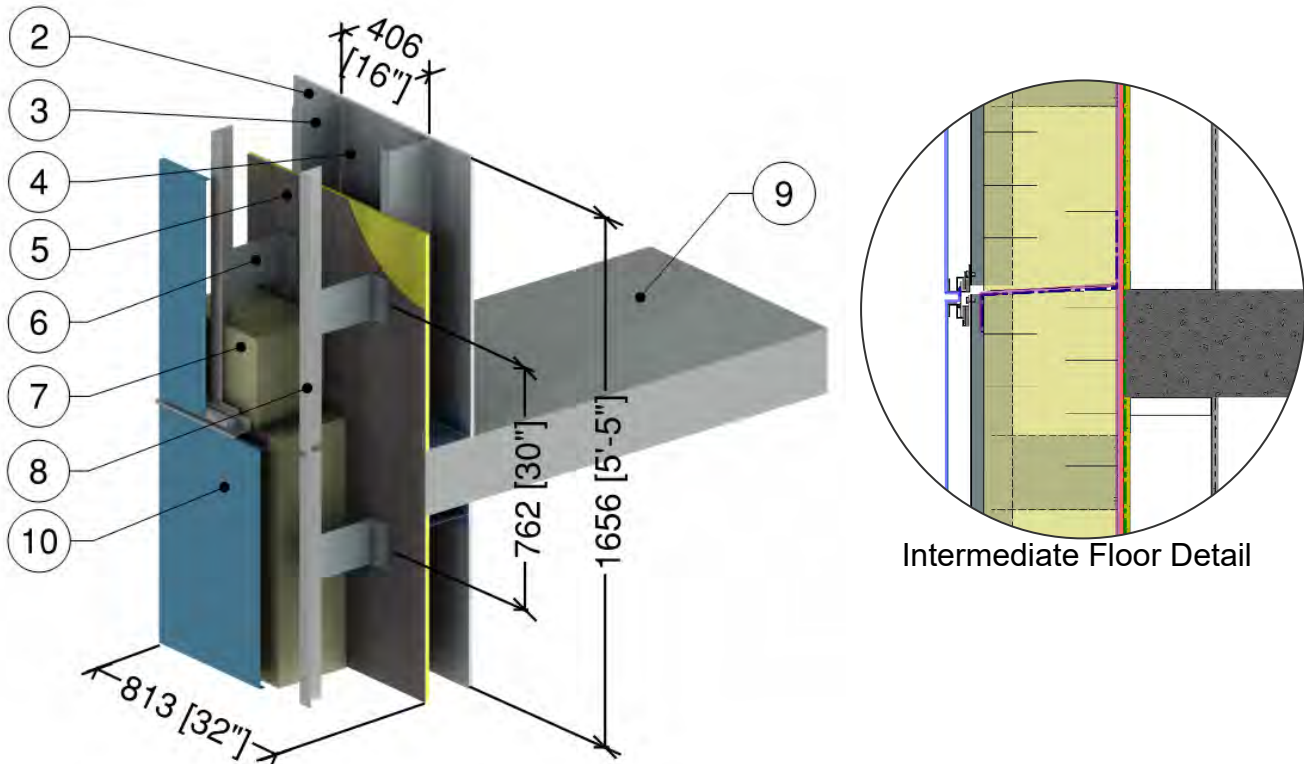

ID	Component	Thickness Inches (mm)	Conductivity Btu-in / ft ² ·hr·°F (W/m K)	Nominal Resistance hr·ft ² ·°F/Btu (m ² K/W)	Density lb/ft ³ (kg/m ³)	Specific Heat Btu/lb·°F (J/kg K)
1	Interior Films ¹	-	-	R-0.6 to R-0.9 (0.11 RSI to 0.16 RSI)	-	-
2	Gypsum Board	1/2" (13)	1.1 (0.16)	R-0.5 (0.08 RSI)	50 (800)	0.26 (1090)
3	6" x 1 5/8" Steel Studs with Tracks	18 Gauge	430 (62)	-	489 (7830)	0.12 (500)
4	Air in Stud Cavity	6" (152)	-	R-0.9 (0.16 RSI)	0.075 (1.2)	0.24 (1000)
5	Exterior Sheathing	1/2" (13)	1.1 (0.16)	R-0.5 (0.08 RSI)	50 (800)	0.26 (1090)
6	FRP Bracket	-	4.9 (0.70)	-	110 (1760)	-
7	Exterior Mineral Wool Insulation	10" (254)	0.24 (0.034)	R-42 (7.40 RSI)	4.5 (72)	0.20 (850)
8	Vertical Aluminum L-Rail	0.09" (2.2)	1110 (160)	-	171 (2739)	0.22 (900)
9	Concrete Slab	8" (203)	12.5 (1.8)	-	140 (2250)	0.20 (850)
10	Metal Cladding with 1/2" vented airspace incorporated into exterior heat transfer coefficient					
11	Exterior Film ¹	-	-	R-0.7 (0.12 RSI)	-	-

¹ Value selected from table 1, p. 26.1 of 2009 ASHRAE Handbook – Fundamentals depending on surface orientation

Detail 5.2.39

Exterior and Interior Insulated 6" x 1 5/8" Steel Stud (16" o.c.) Wall Assembly with FRP Vertical Brackets and Rail System Supporting Metal Cladding and R-19 Batt in Stud Cavity – Intermediate Floor Intersection

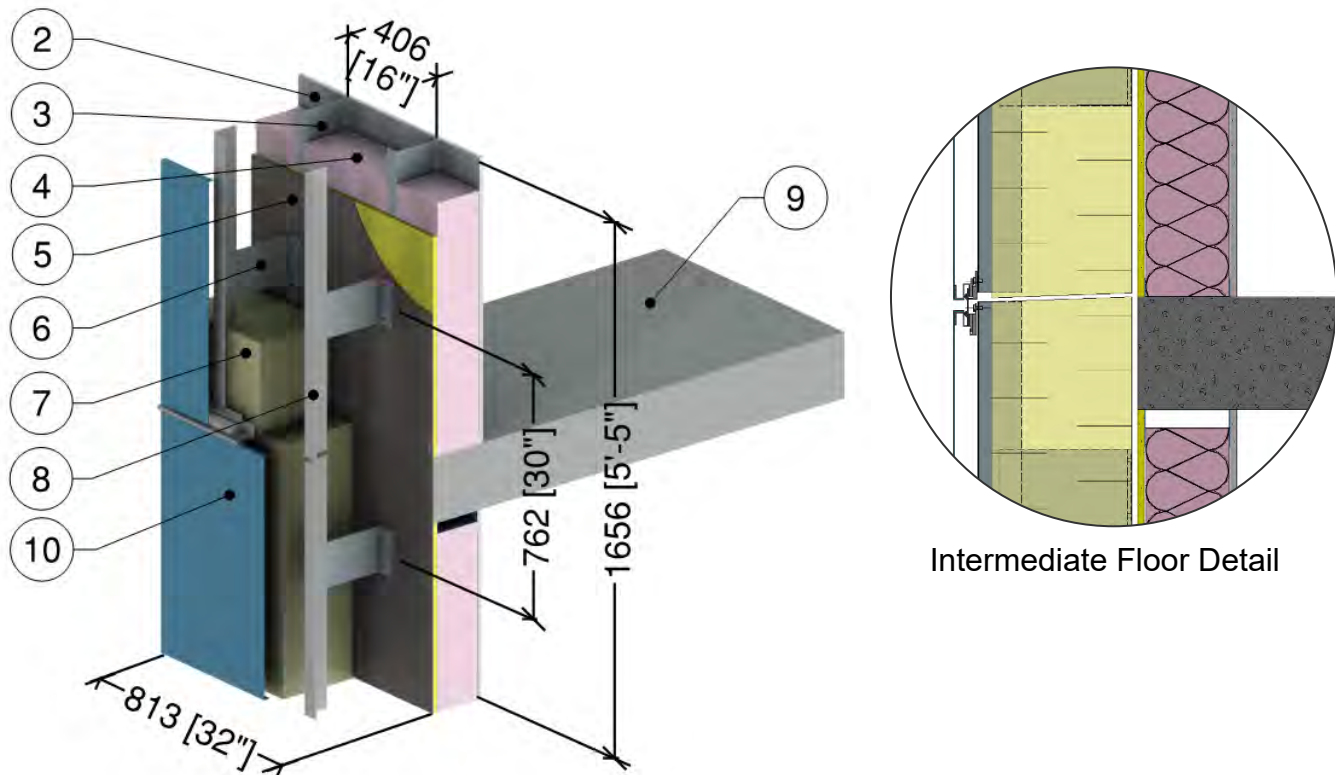

ID	Component	Thickness Inches (mm)	Conductivity Btu-in / ft ² ·hr·°F (W/m K)	Nominal Resistance hr·ft ² ·°F/Btu (m ² K/W)	Density lb/ft ³ (kg/m ³)	Specific Heat Btu/lb·°F (J/kg K)
1	Interior Films ¹	-	-	R-0.6 to R-0.9 (0.11 RSI to 0.16 RSI)	-	-
2	Gypsum Board	1/2" (13)	1.1 (0.16)	R-0.5 (0.08 RSI)	50 (800)	0.26 (1090)
3	6" x 1 5/8" Steel Studs with Tracks	18 Gauge	430 (62)	-	489 (7830)	0.12 (500)
4	Fiberglass Batt Insulation	6" (152)	-	R-19 (3.35 RSI)	0.9 (14)	0.17 (710)
5	Exterior Sheathing	1/2" (13)	1.1 (0.16)	R-0.5 (0.08 RSI)	50 (800)	0.26 (1090)
6	FRP Bracket	-	4.9 (0.70)	-	110 (1760)	-
7	Exterior Mineral Wool Insulation	10" (254)	0.24 (0.034)	R-42 (7.40 RSI)	4.5 (72)	0.20 (850)
8	Vertical Aluminum L-Rail	0.09" (2.2)	1110 (160)	-	171 (2739)	0.22 (900)
9	Concrete Slab	8" (203)	12.5 (1.8)	-	140 (2250)	0.20 (850)
10	Metal Cladding with 1/2" vented airspace incorporated into exterior heat transfer coefficient					
11	Exterior Film ¹	-	-	R-0.7 (0.12 RSI)	-	-

¹ Value selected from table 1, p. 26.1 of 2009 ASHRAE Handbook – Fundamentals depending on surface orientation

Detail 5.2.40

Exterior Insulated 3 5/8" x 1 5/8" Steel Stud (16" o.c.) Wall Assembly with Horizontal Z-girts (24" o.c.) Supporting Metal Cladding – Isokorb K65-V8 Thermally Broken Slab Projection with Insulated Curb

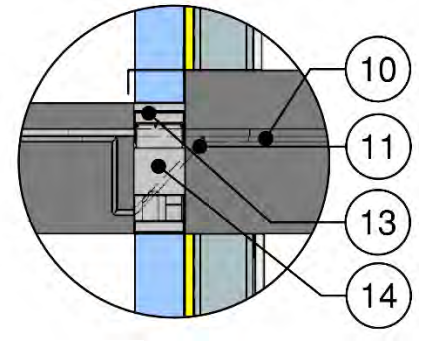
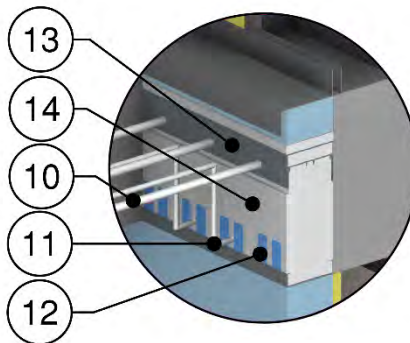
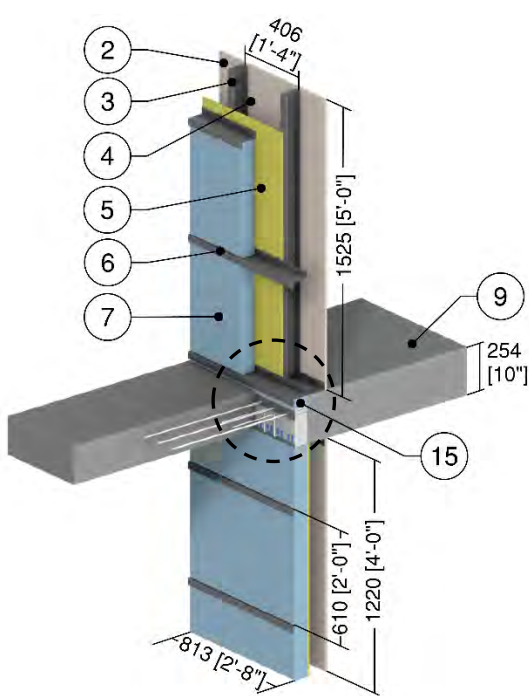

Isokorb K65-V8 Detail

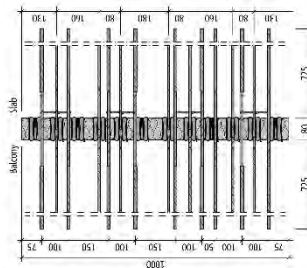

Isokorb K65-V8 Rebar Arrangement

ID	Component	Thickness Inches (mm)	Conductivity Btu-in / ft ² ·hr·°F (W/m K)	Nominal Resistance hr·ft ² ·°F/Btu (m ² K/W)	Density lb/ft ³ (kg/m ³)	Specific Heat Btu/lb·°F (J/kg K)
1	Interior Films ¹	-	-	R-0.6 to R-0.9 (0.11 RSI to 0.16 RSI)	-	-
2	Gypsum Board	1/2" (13)	1.1 (0.16)	R-0.5 (0.08 RSI)	50 (800)	0.26 (1090)
3	3 5/8" x 1 5/8" Steel Studs with Top and Bottom Tracks	18 Gauge	430 (62)	-	489 (7830)	0.12 (500)
4	Air in Stud Cavity	3 5/8" (92)	-	R-0.9 (0.16 RSI)	0.075 (1.2)	0.24 (1000)
5	Exterior Sheathing	1/2" (13)	1.1 (0.16)	R-0.5 (0.08 RSI)	50 (800)	0.26 (1090)
6	Horizontal Z-girts w/ 1 1/2" Flange	18 Gauge	430 (62)	-	489 (7830)	0.12 (500)
7	Exterior Insulation	3" (76)	-	R-15.0 (2.64 RSI)	1.8 (28)	0.29 (1220)
8	Metal Cladding with 1/2" vented airspace incorporated into exterior heat transfer coefficient					
9	Concrete Slab	10" (254)	12.5 (1.8)	-	140 (2250)	0.20 (850)
10	Steel Rebar	-	347 (50)	-	489 (7830)	0.12 (500)
11	Stainless Steel Rebar	-	118 (17)	-	500 (8000)	0.12 (500)
12	Plastic Sleeve	-	1.7 (0.25)	-	72 (1150)	0.20 (850)
13	Isokorb Frame	-	1.7 (0.25)	-	72 (1150)	0.20 (850)
14	Polystyrene Insulation	3.2" (80)	0.22 (0.031)	R-15 (2.58 RSI)	1.3 (20)	0.35 (1500)
15	Curb Insulation	3" (76)	-	R-15 (2.64 RSI)	1.8 (28)	0.29 (1220)
16	Exterior Film ¹	-	-	R-0.2 to R-0.7 (0.03 RSI to 0.12 RSI)	-	-

¹ Value selected from table 1, p. 26.1 of 2009 ASHRAE Handbook – Fundamentals depending on surface orientation

Detail 5.2.41

Exterior Insulated 3 5/8" x 1 5/8" Steel Stud (16" o.c.) Wall Assembly with Horizontal Z-girts (24" o.c.) Supporting Metal Cladding – Isokorb K10-V6 Thermally Broken Slab Projection with Insulated Curb

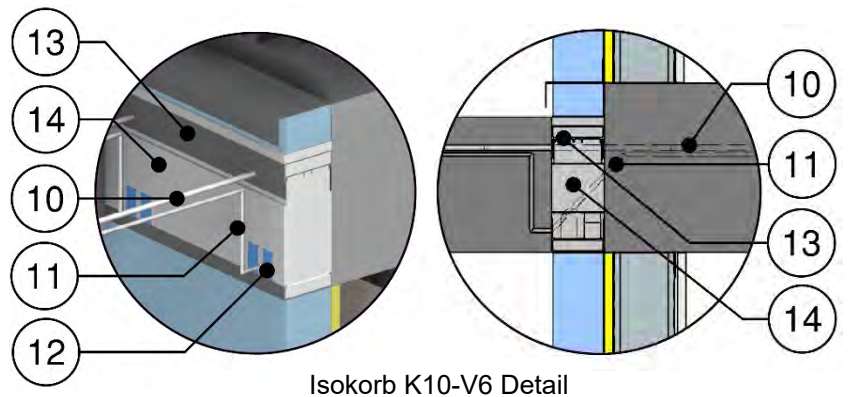
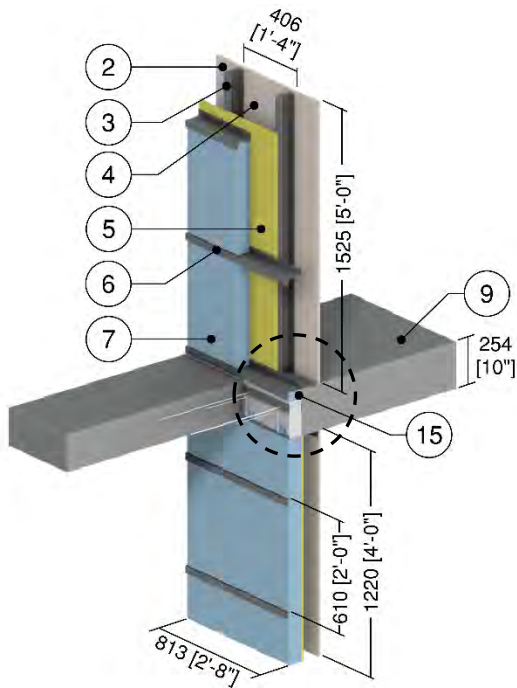

Isokorb K10-V6 Detail

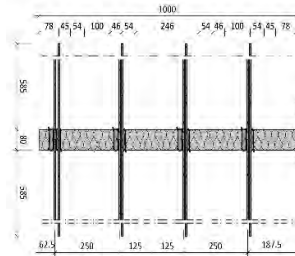

Isokorb K10-V6 Rebar Arrangement

ID	Component	Thickness Inches (mm)	Conductivity Btu-in / ft ² ·hr·°F (W/m K)	Nominal Resistance hr·ft ² ·°F/Btu (m ² K/W)	Density lb/ft ³ (kg/m ³)	Specific Heat Btu/lb·°F (J/kg K)
1	Interior Films ¹	-	-	R-0.6 to R-0.9 (0.11 RSI to 0.16 RSI)	-	-
2	Gypsum Board	1/2" (13)	1.1 (0.16)	R-0.5 (0.08 RSI)	50 (800)	0.26 (1090)
3	3 5/8" x 1 5/8" Steel Studs with Top and Bottom Tracks	18 Gauge	430 (62)	-	489 (7830)	0.12 (500)
4	Air in Stud Cavity	3 5/8" (92)	-	R-0.9 (0.16 RSI)	0.075 (1.2)	0.24 (1000)
5	Exterior Sheathing	1/2" (13)	1.1 (0.16)	R-0.5 (0.08 RSI)	50 (800)	0.26 (1090)
6	Horizontal Z-girts w/ 1 1/2" Flange	18 Gauge	430 (62)	-	489 (7830)	0.12 (500)
7	Exterior Insulation	3" (76)	-	R-15.0 (2.64 RSI)	1.8 (28)	0.29 (1220)
8	Metal Cladding with 1/2" vented airspace incorporated into exterior heat transfer coefficient					
9	Concrete Slab	10" (254)	12.5 (1.8)	-	140 (2250)	0.20 (850)
10	Steel Rebar	-	347 (50)	-	489 (7830)	0.12 (500)
11	Stainless Steel Rebar	-	118 (17)	-	500 (8000)	0.12 (500)
12	Plastic Sleeve	-	1.7 (0.25)	-	72 (1150)	0.20 (850)
13	Isokorb Frame	-	1.7 (0.25)	-	72 (1150)	0.20 (850)
14	Polystyrene Insulation	3.2" (80)	0.22 (0.031)	R-15 (2.58 RSI)	1.3 (20)	0.35 (1500)
15	Curb Insulation	3" (76)	-	R-15 (2.64 RSI)	1.8 (28)	0.29 (1220)
16	Exterior Film ¹	-	-	R-0.2 to R-0.7 (0.03 RSI to 0.12 RSI)	-	-

¹ Value selected from table 1, p. 26.1 of 2009 ASHRAE Handbook – Fundamentals depending on surface orientation

Detail 5.2.42

Exterior Insulated 3 5/8" x 1 5/8" Steel Stud (16" o.c.) Wall Assembly with Horizontal Z-girts (24" o.c.) Supporting Metal Cladding – Isokorb KXT65-V8 Thermally Broken Slab Projection with Insulated Curb

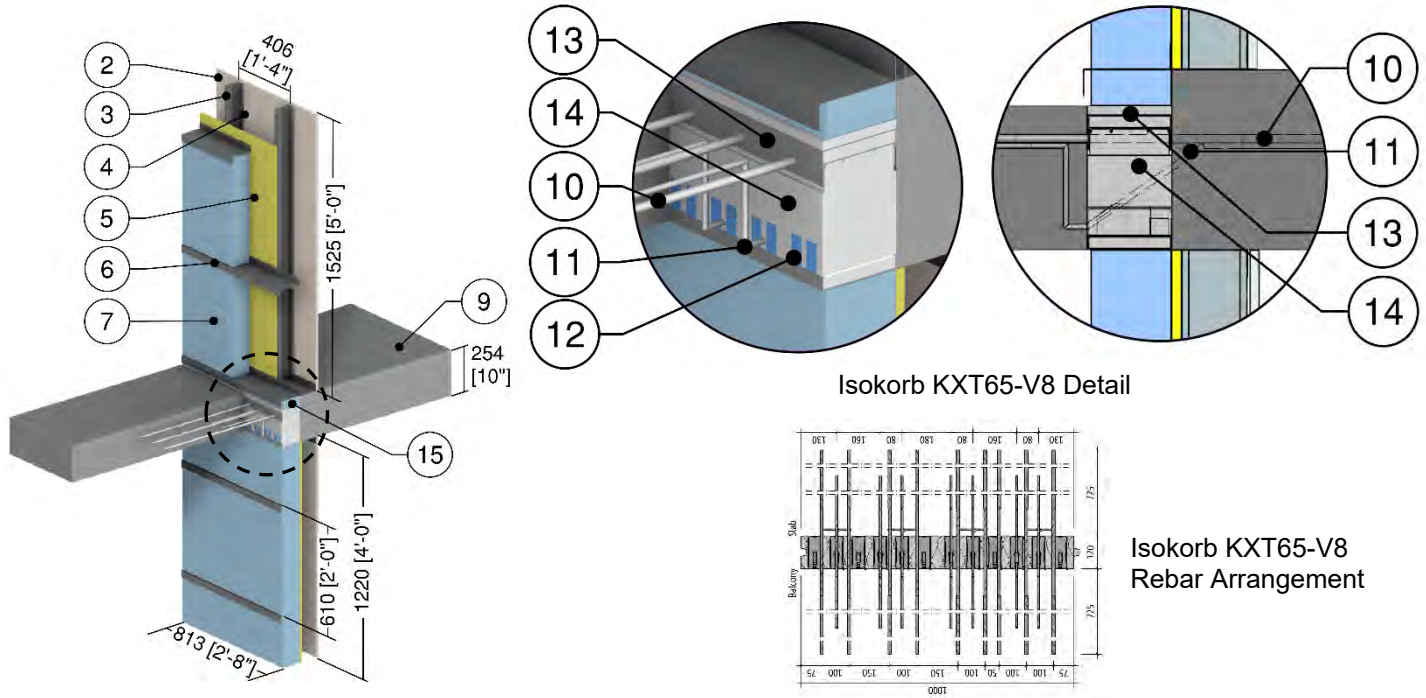

ID	Component	Thickness Inches (mm)	Conductivity Btu-in / ft ² ·hr·°F (W/m K)	Nominal Resistance hr·ft ² ·°F/Btu (m ² K/W)	Density lb/ft ³ (kg/m ³)	Specific Heat Btu/lb·°F (J/kg K)
1	Interior Films ¹	-	-	R-0.6 to R-0.9 (0.11 RSI to 0.16 RSI)	-	-
2	Gypsum Board	1/2" (13)	1.1 (0.16)	R-0.5 (0.08 RSI)	50 (800)	0.26 (1090)
3	3 5/8" x 1 5/8" Steel Studs with Top and Bottom Tracks	18 Gauge	430 (62)	-	489 (7830)	0.12 (500)
4	Air in Stud Cavity	3 5/8" (92)	-	R-0.9 (0.16 RSI)	0.075 (1.2)	0.24 (1000)
5	Exterior Sheathing	1/2" (13)	1.1 (0.16)	R-0.5 (0.08 RSI)	50 (800)	0.26 (1090)
6	Horizontal Z-girts w/ 1 1/2" Flange	18 Gauge	430 (62)	-	489 (7830)	0.12 (500)
7	Exterior Insulation	4.5" (114)	-	R-22.5 (3.96 RSI)	1.8 (28)	0.29 (1220)
8	Metal Cladding with 1/2" vented airspace incorporated into exterior heat transfer coefficient					
9	Concrete Slab	10" (254)	12.5 (1.8)	-	140 (2250)	0.20 (850)
10	Steel Rebar	-	347 (50)	-	489 (7830)	0.12 (500)
11	Stainless Steel Rebar	-	118 (17)	-	500 (8000)	0.12 (500)
12	Plastic Sleeve	-	1.7 (0.25)	-	72 (1150)	0.20 (850)
13	Isokorb Frame	-	1.7 (0.25)	-	72 (1150)	0.20 (850)
14	Polystyrene Insulation	4.7" (120)	0.22 (0.031)	R-21.7 (3.83 RSI)	1.3 (20)	0.35 (1500)
15	Curb Insulation	4.5" (114)	-	R-22.5 (3.96 RSI)	1.8 (28)	0.29 (1220)
16	Exterior Film ¹	-	-	R-0.2 to R-0.7 (0.03 RSI to 0.12 RSI)	-	-

¹ Value selected from table 1, p. 26.1 of 2009 ASHRAE Handbook – Fundamentals depending on surface orientation

Detail 5.2.43

Exterior Insulated 3 5/8" x 1 5/8" Steel Stud (16" o.c.) Wall Assembly with Horizontal Z-girts (24" o.c.) Supporting Metal Cladding – Isokorb KXT15-V6 Thermally Broken Slab Projection with Insulated Curb

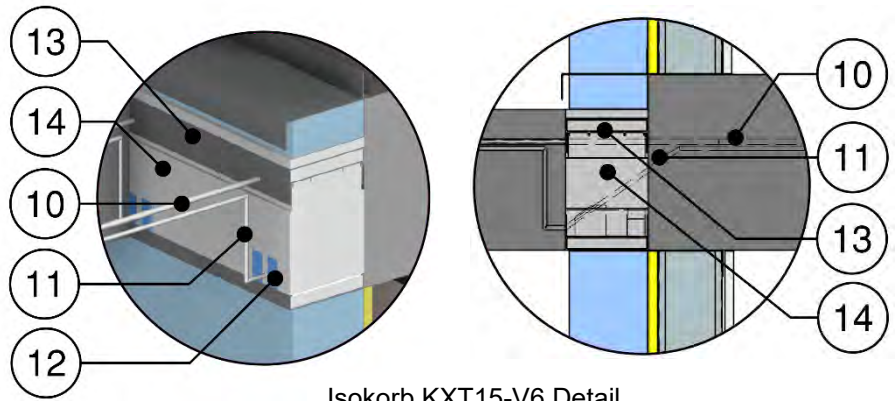
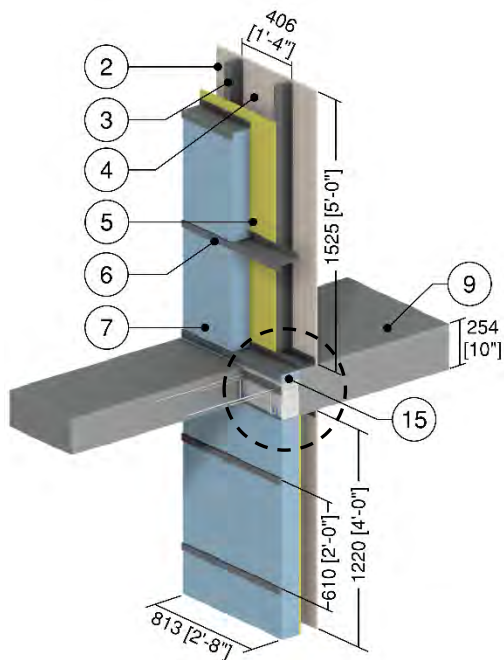

Isokorb KXT15-V6 Detail

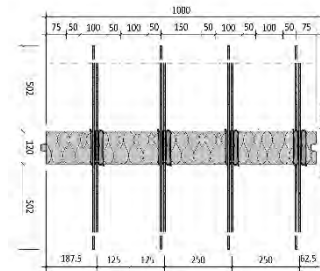

Isokorb KXT15-V6 Rebar Arrangement

ID	Component	Thickness Inches (mm)	Conductivity Btu-in / ft ² ·hr·°F (W/m K)	Nominal Resistance hr·ft ² ·°F/Btu (m ² K/W)	Density lb/ft ³ (kg/m ³)	Specific Heat Btu/lb·°F (J/kg K)
1	Interior Films ¹	-	-	R-0.6 to R-0.9 (0.11 RSI to 0.16 RSI)	-	-
2	Gypsum Board	1/2" (13)	1.1 (0.16)	R-0.5 (0.08 RSI)	50 (800)	0.26 (1090)
3	3 5/8" x 1 5/8" Steel Studs with Top and Bottom Tracks	18 Gauge	430 (62)	-	489 (7830)	0.12 (500)
4	Air in Stud Cavity	3 5/8" (92)	-	R-0.9 (0.16 RSI)	0.075 (1.2)	0.24 (1000)
5	Exterior Sheathing	1/2" (13)	1.1 (0.16)	R-0.5 (0.08 RSI)	50 (800)	0.26 (1090)
6	Horizontal Z-girts w/ 1 1/2" Flange	18 Gauge	430 (62)	-	489 (7830)	0.12 (500)
7	Exterior Insulation	4.5" (114)	-	R-22.5 (3.96 RSI)	1.8 (28)	0.29 (1220)
8	Metal Cladding with 1/2" vented airspace incorporated into exterior heat transfer coefficient					
9	Concrete Slab	10" (254)	12.5 (1.8)	-	140 (2250)	0.20 (850)
10	Steel Rebar	-	347 (50)	-	489 (7830)	0.12 (500)
11	Stainless Steel Rebar	-	118 (17)	-	500 (8000)	0.12 (500)
12	Plastic Sleeve	-	1.7 (0.25)	-	72 (1150)	0.20 (850)
13	Isokorb Frame	-	1.7 (0.25)	-	72 (1150)	0.20 (850)
14	Polystyrene Insulation	4.7" (120)	0.22 (0.031)	R-21.7 (3.83 RSI)	1.3 (20)	0.35 (1500)
15	Curb Insulation	4.5" (114)	-	R-22.5 (3.96 RSI)	1.8 (28)	0.29 (1220)
16	Exterior Film ¹	-	-	R-0.2 to R-0.7 (0.03 RSI to 0.12 RSI)	-	-

¹ Value selected from table 1, p. 26.1 of 2009 ASHRAE Handbook – Fundamentals depending on surface orientation

Detail 5.2.44

Exterior and Interior Insulated 3 5/8" x 1 5/8" Steel Stud (16" o.c.) Wall Assembly with Horizontal Z-girts (24" o.c.) Supporting Metal Cladding and R-12 Batt Insulation in Stud Cavity – Isokorb K65-V8 Thermally Broken Slab Projection with Insulated Curb

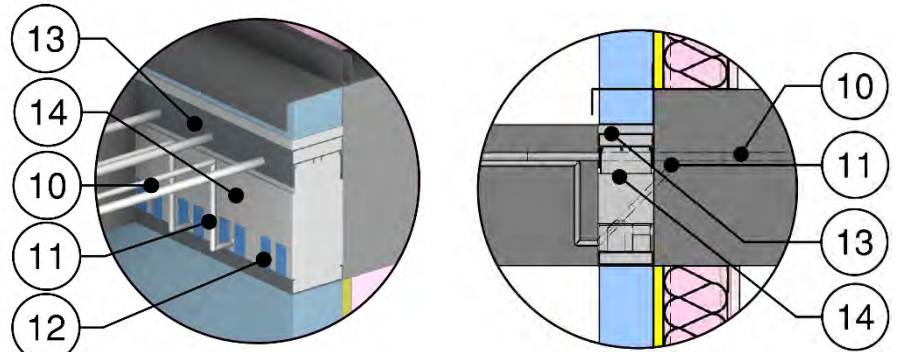
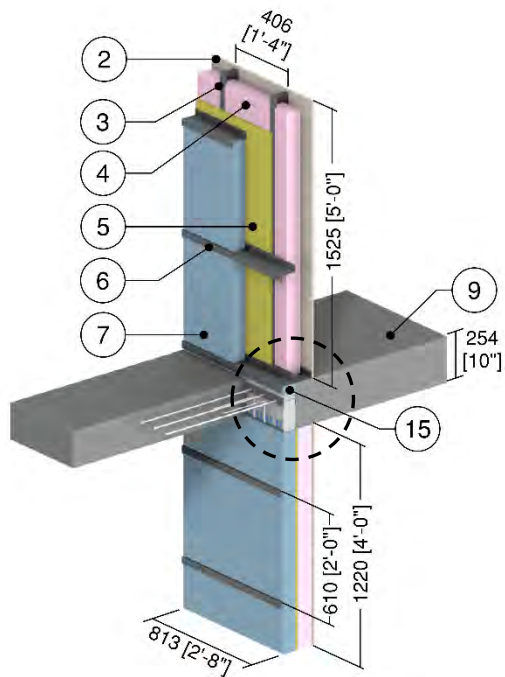

Isokorb K65-V8 Detail

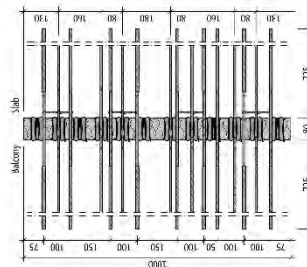

Isokorb K65-V8 Rebar Arrangement

ID	Component	Thickness Inches (mm)	Conductivity Btu-in / ft ² ·hr·°F (W/m K)	Nominal Resistance hr·ft ² ·°F/Btu (m ² K/W)	Density lb/ft ³ (kg/m ³)	Specific Heat Btu/lb·°F (J/kg K)
1	Interior Films ¹	-	-	R-0.6 to R-0.9 (0.11 RSI to 0.16 RSI)	-	-
2	Gypsum Board	1/2" (13)	1.1 (0.16)	R-0.5 (0.08 RSI)	50 (800)	0.26 (1090)
3	3 5/8" x 1 5/8" Steel Studs with Top and Bottom Tracks	18 Gauge	430 (62)	-	489 (7830)	0.12 (500)
4	Fiberglass Batt Insulation	3 5/8" (92)	0.30 (0.044)	R-12 (2.1 RSI)	0.9 (14)	0.17 (710)
5	Exterior Sheathing	1/2" (13)	1.1 (0.16)	R-0.5 (0.08 RSI)	50 (800)	0.26 (1090)
6	Horizontal Z-girts w/ 1 1/2" Flange	18 Gauge	430 (62)	-	489 (7830)	0.12 (500)
7	Exterior Insulation	3" (76)	-	R-15.0 (2.64 RSI)	1.8 (28)	0.29 (1220)
8	Metal Cladding with 1/2" vented airspace incorporated into exterior heat transfer coefficient					
9	Concrete Slab	10" (254)	12.5 (1.8)	-	140 (2250)	0.20 (850)
10	Steel Rebar	-	347 (50)	-	489 (7830)	0.12 (500)
11	Stainless Steel Rebar	-	118 (17)	-	500 (8000)	0.12 (500)
12	Plastic Sleeve	-	1.7 (0.25)	-	72 (1150)	0.20 (850)
13	Isokorb Frame	-	1.7 (0.25)	-	72 (1150)	0.20 (850)
14	Polystyrene Insulation	3.2" (80)	0.22 (0.031)	R-15 (2.58 RSI)	1.3 (20)	0.35 (1500)
15	Curb Insulation	3" (76)	-	R-15 (2.64 RSI)	1.8 (28)	0.29 (1220)
16	Exterior Film ¹	-	-	R-0.2 to R-0.7 (0.03 RSI to 0.12 RSI)	-	-

¹ Value selected from table 1, p. 26.1 of 2009 ASHRAE Handbook – Fundamentals depending on surface orientation

Detail 5.2.45

Exterior and Interior Insulated 3 5/8" x 1 5/8" Steel Stud (16" o.c.) Wall Assembly with Horizontal Z-girts (24" o.c.) Supporting Metal Cladding and R-12 Batt Insulation in Stud Cavity – Isokorb K10-V6 Thermally Broken Slab Projection with Insulated Curb

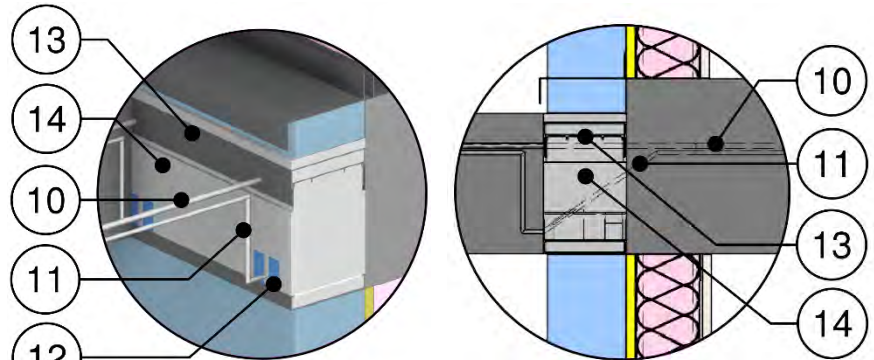
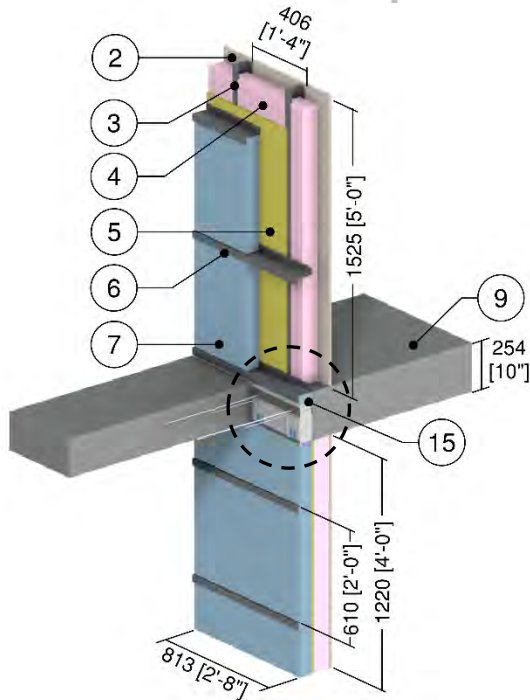

Isokorb K10-V6 Detail

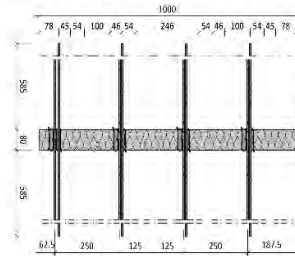

Isokorb K10-V6 Rebar Arrangement

ID	Component	Thickness Inches (mm)	Conductivity Btu-in / ft ² ·hr·°F (W/m K)	Nominal Resistance hr·ft ² ·°F/Btu (m ² K/W)	Density lb/ft ³ (kg/m ³)	Specific Heat Btu/lb·°F (J/kg K)
1	Interior Films ¹	-	-	R-0.6 to R-0.9 (0.11 RSI to 0.16 RSI)	-	-
2	Gypsum Board	1/2" (13)	1.1 (0.16)	R-0.5 (0.08 RSI)	50 (800)	0.26 (1090)
3	3 5/8" x 1 5/8" Steel Studs with Top and Bottom Tracks	18 Gauge	430 (62)	-	489 (7830)	0.12 (500)
4	Fiberglass Batt Insulation	3 5/8" (92)	0.30 (0.044)	R-12 (2.1 RSI)	0.9 (14)	0.17 (710)
5	Exterior Sheathing	1/2" (13)	1.1 (0.16)	R-0.5 (0.08 RSI)	50 (800)	0.26 (1090)
6	Horizontal Z-girts w/ 1 1/2" Flange	18 Gauge	430 (62)	-	489 (7830)	0.12 (500)
7	Exterior Insulation	3" (76)	-	R-15.0 (2.64 RSI)	1.8 (28)	0.29 (1220)
8	Metal Cladding with 1/2" vented airspace incorporated into exterior heat transfer coefficient					
9	Concrete Slab	10" (254)	12.5 (1.8)	-	140 (2250)	0.20 (850)
10	Steel Rebar	-	347 (50)	-	489 (7830)	0.12 (500)
11	Stainless Steel Rebar	-	118 (17)	-	500 (8000)	0.12 (500)
12	Plastic Sleeve	-	1.7 (0.25)	-	72 (1150)	0.20 (850)
13	Isokorb Frame	-	1.7 (0.25)	-	72 (1150)	0.20 (850)
14	Polystyrene Insulation	3.2" (80)	0.22 (0.031)	R-15 (2.58 RSI)	1.3 (20)	0.35 (1500)
15	Curb Insulation	3" (76)	-	R-15 (2.64 RSI)	1.8 (28)	0.29 (1220)
16	Exterior Film ¹	-	-	R-0.2 to R-0.7 (0.03 RSI to 0.12 RSI)	-	-

¹ Value selected from table 1, p. 26.1 of 2009 ASHRAE Handbook – Fundamentals depending on surface orientation

Detail 5.2.46

Exterior and Interior Insulated 3 5/8" x 1 5/8" Steel Stud (16" o.c.) Wall Assembly with Horizontal Z-girts (24" o.c.) Supporting Metal Cladding and R-12 Batt Insulation in Stud Cavity – Isokorb KXT65-V8 Thermally Broken Slab Projection with Insulated Curb

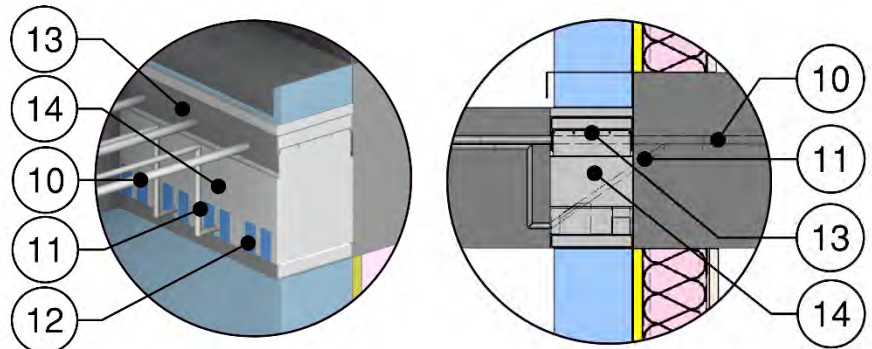
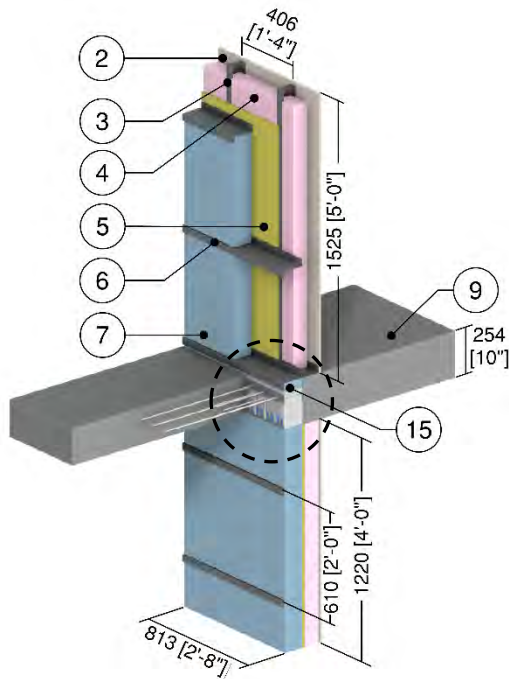

Isokorb KXT65-V8 Detail

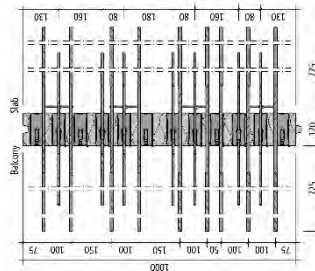

Isokorb KXT65-V8 Rebar Arrangement

ID	Component	Thickness Inches (mm)	Conductivity Btu-in / ft ² ·hr·°F (W/m K)	Nominal Resistance hr·ft ² ·°F/Btu (m ² K/W)	Density lb/ft ³ (kg/m ³)	Specific Heat Btu/lb·°F (J/kg K)
1	Interior Films ¹	-	-	R-0.6 to R-0.9 (0.11 RSI to 0.16 RSI)	-	-
2	Gypsum Board	1/2" (13)	1.1 (0.16)	R-0.5 (0.08 RSI)	50 (800)	0.26 (1090)
3	3 5/8" x 1 5/8" Steel Studs with Top and Bottom Tracks	18 Gauge	430 (62)	-	489 (7830)	0.12 (500)
4	Fiberglass Batt Insulation	3 5/8" (92)	0.30 (0.044)	R-12 (2.1 RSI)	0.9 (14)	0.17 (710)
5	Exterior Sheathing	1/2" (13)	1.1 (0.16)	R-0.5 (0.08 RSI)	50 (800)	0.26 (1090)
6	Horizontal Z-girts w/ 1 1/2" Flange	18 Gauge	430 (62)	-	489 (7830)	0.12 (500)
7	Exterior Insulation	4.5" (114)	-	R-22.5 (3.96 RSI)	1.8 (28)	0.29 (1220)
8	Metal Cladding with 1/2" vented airspace incorporated into exterior heat transfer coefficient					
9	Concrete Slab	10" (254)	12.5 (1.8)	-	140 (2250)	0.20 (850)
10	Steel Rebar	-	347 (50)	-	489 (7830)	0.12 (500)
11	Stainless Steel Rebar	-	118 (17)	-	500 (8000)	0.12 (500)
12	Plastic Sleeve	-	1.7 (0.25)	-	72 (1150)	0.20 (850)
13	Isokorb Frame	-	1.7 (0.25)	-	72 (1150)	0.20 (850)
14	Polystyrene Insulation	4.7" (120)	0.22 (0.031)	R-21.7 (3.83 RSI)	1.3 (20)	0.35 (1500)
15	Curb Insulation	4.5" (114)	-	R-22.5 (3.96 RSI)	1.8 (28)	0.29 (1220)
16	Exterior Film ¹	-	-	R-0.2 to R-0.7 (0.03 RSI to 0.12 RSI)	-	-

¹ Value selected from table 1, p. 26.1 of 2009 ASHRAE Handbook – Fundamentals depending on surface orientation

Detail 5.2.47

Exterior and Interior Insulated 3 5/8" x 1 5/8" Steel Stud (16" o.c.) Wall Assembly with Horizontal Z-girts (24" o.c.) Supporting Metal Cladding and R-12 Batt Insulation in Stud Cavity – Isokorb KXT15-V6 Thermally Broken Slab Projection with Insulated Curb

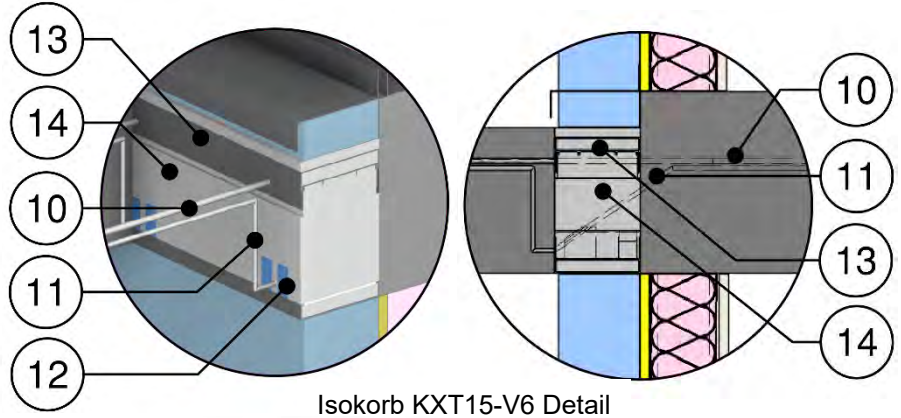
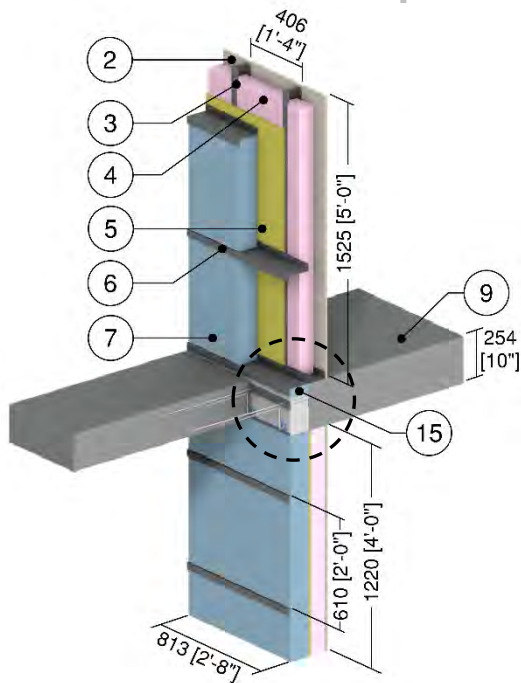

Isokorb KXT15-V6 Detail

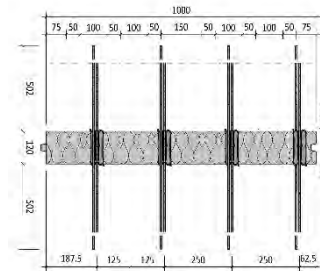

Isokorb KXT15-V6 Rebar Arrangement

ID	Component	Thickness Inches (mm)	Conductivity Btu-in / ft ² ·hr·°F (W/m K)	Nominal Resistance hr·ft ² ·°F/Btu (m ² K/W)	Density lb/ft ³ (kg/m ³)	Specific Heat Btu/lb·°F (J/kg K)
1	Interior Films ¹	-	-	R-0.6 to R-0.9 (0.11 RSI to 0.16 RSI)	-	-
2	Gypsum Board	1/2" (13)	1.1 (0.16)	R-0.5 (0.08 RSI)	50 (800)	0.26 (1090)
3	3 5/8" x 1 5/8" Steel Studs with Top and Bottom Tracks	18 Gauge	430 (62)	-	489 (7830)	0.12 (500)
4	Fiberglass Batt Insulation	3 5/8" (92)	0.30 (0.044)	R-12 (2.1 RSI)	0.9 (14)	0.17 (710)
5	Exterior Sheathing	1/2" (13)	1.1 (0.16)	R-0.5 (0.08 RSI)	50 (800)	0.26 (1090)
6	Horizontal Z-girts w/ 1 1/2" Flange	18 Gauge	430 (62)	-	489 (7830)	0.12 (500)
7	Exterior Insulation	4.5" (114)	-	R-22.5 (3.96 RSI)	1.8 (28)	0.29 (1220)
8	Metal Cladding with 1/2" vented airspace incorporated into exterior heat transfer coefficient					
9	Concrete Slab	10" (254)	12.5 (1.8)	-	140 (2250)	0.20 (850)
10	Steel Rebar	-	347 (50)	-	489 (7830)	0.12 (500)
11	Stainless Steel Rebar	-	118 (17)	-	500 (8000)	0.12 (500)
12	Plastic Sleeve	-	1.7 (0.25)	-	72 (1150)	0.20 (850)
13	Isokorb Frame	-	1.7 (0.25)	-	72 (1150)	0.20 (850)
14	Polystyrene Insulation	4.7" (120)	0.22 (0.031)	R-21.7 (3.83 RSI)	1.3 (20)	0.35 (1500)
15	Curb Insulation	4.5" (114)	-	R-22.5 (3.96 RSI)	1.8 (28)	0.29 (1220)
16	Exterior Film ¹	-	-	R-0.2 to R-0.7 (0.03 RSI to 0.12 RSI)	-	-

¹ Value selected from table 1, p. 26.1 of 2009 ASHRAE Handbook – Fundamentals depending on surface orientation

Detail 5.2.48

Exterior and Interior Insulated Wall Assembly with Stainless Steel Spaced Shelf Angle & Brick Ties Supporting Brick Veneer and R-12 Batt Insulation in Stud Cavity – Intermediate Floor Intersection

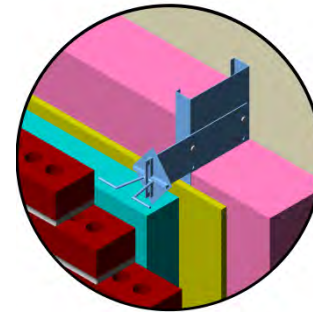
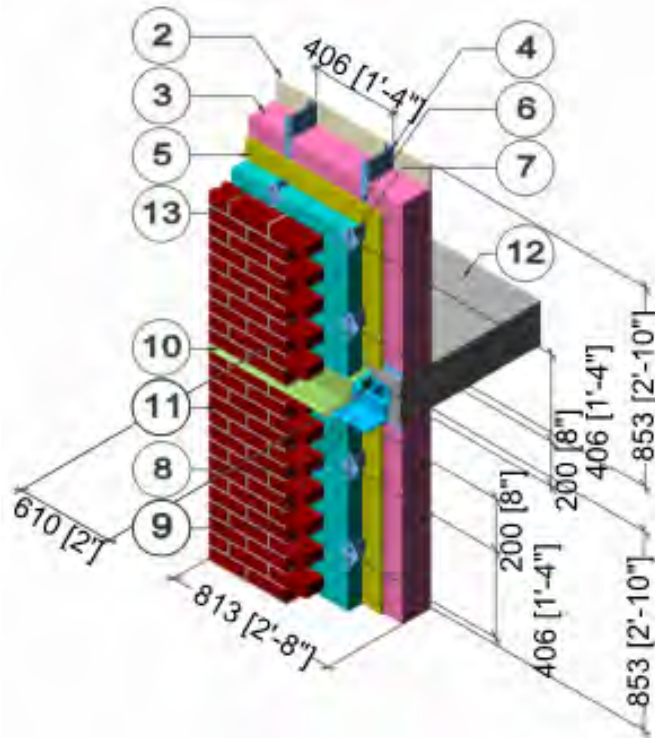

Brick Tie Detail

ID	Component	Thickness Inches (mm)	Conductivity Btu-in / ft ² -hr-°F (W/m K)	Nominal Resistance hr-ft ² -°F/Btu (m ² K/W)	Density lb/ft ³ (kg/m ³)	Specific Heat Btu/lb-°F (J/kg K)
1	Interior Film ¹	-	-	R-0.6 to R-0.9 (0.11 RSI to 0.16 RSI)	-	-
2	Gypsum Board	1/2" (13)	1.1 (0.16)	R-0.5 (0.08 RSI)	50 (800)	0.26 (1090)
3	Fiberglass Batt Insulation	3 5/8" (92)	0.30 (0.044)	R-12 (2.1 RSI)	0.9 (14)	0.17 (710)
4	3 5/8" x 1 5/8" Steel Studs with Top and Bottom Tracks	18 Gauge	430 (62)	-	489 (7830)	0.12 (500)
5	Exterior Sheathing	1/2" (13)	1.1 (0.16)	R-0.5 (0.08 RSI)	50 (800)	0.26 (1090)
6	Exterior Insulation	Varies	-	R-5 to R-25 (0.88 RSI to 4.4 RSI)	1.8 (28)	0.29 (1220)
7	Brick Ties	14 Gauge	347 (50)	-	489 (7830)	0.12 (500)
8	Exterior Insulation Behind Shelf Angle	Varies	-	R-5 to R-25 (0.88 RSI to 4.4 RSI)	1.8 (28)	0.29 (1220)
9	Stainless Steel Spaced Shelf Angle	3/8" (10)	118 (17)	-	500 (8000)	0.12 (500)
10	Flashing	20 Gauge	347 (50)	-	489 (7830)	0.12 (500)
11	Brick Veneer	3 5/8" (92)	5.4 (0.78)	-	120 (1920)	0.19 (720)
12	Concrete Slab	8" (203)	12.5 (1.8)	-	140 (2250)	0.20 (850)
13	Air Gap	1" (25)	-	R-0.9 (0.16 RSI)	0.075 (1.2)	0.24 (1000)
14	Exterior Film ¹	-	-	R-0.2 (0.03 RSI)	-	-

¹ Value selected from table 1, p. 26.1 of 2009 ASHRAE Handbook – Fundamentals depending on surface orientation

Detail 5.2.49

Exterior and Interior Insulated Wall Assembly with Thermally Broken Stainless Steel Shelf Angle & Brick Ties Supporting Brick Veneer and R-12 Batt Insulation in Stud Cavity – Slab Intersection

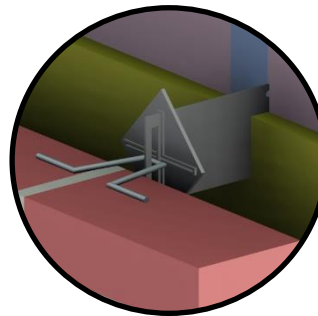
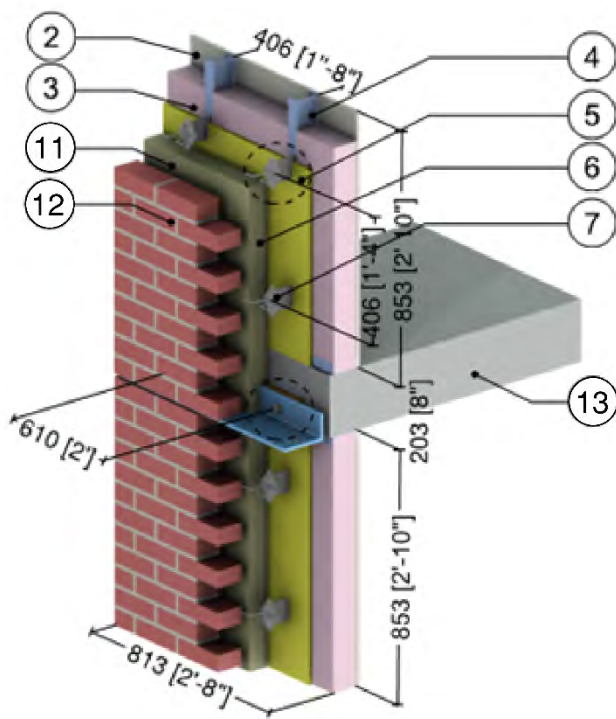

Brick Tie Detail

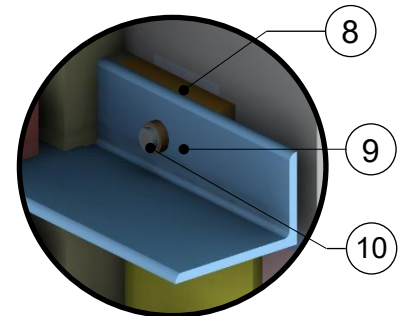

Shelf Angle Detail



Shelf angle outboard of R-5 insulation

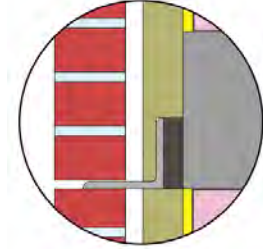

Insulation covers shelf angle for scenarios R-10+

ID	Component	Thickness Inches (mm)	Conductivity Btu-in / ft ² -hr-°F (W/m K)	Nominal Resistance hr-ft ² -°F/Btu (m ² K/W)	Density lb/ft ³ (kg/m ³)	Specific Heat Btu/lb-°F (J/kg K)
1	Interior Film ¹	-	-	R-0.6 to R-0.9 (0.11 RSI to 0.16 RSI)	-	-
2	Gypsum Board	1/2" (13)	1.1 (0.16)	R-0.5 (0.08 RSI)	50 (800)	0.26 (1090)
3	Fiberglass Batt Insulation	3 5/8" (92)	0.30 (0.044)	R-12 (2.1 RSI)	0.9 (14)	0.17 (710)
4	3 5/8" x 1 5/8" Steel Studs with Top and Bottom Tracks	18 Gauge	430 (62)	-	489 (7830)	0.12 (500)
5	Exterior Sheathing	1/2" (13)	1.1 (0.16)	R-0.5 (0.08 RSI)	50 (800)	0.26 (1090)
6	Exterior Insulation	Varies	-	R-5 to R-25 (0.88 RSI to 4.4 RSI)	1.8 (28)	0.29 (1220)
7	Brick Ties	14 Gauge	347 (50)	-	489 (7830)	0.12 (500)
8	Armatherm FRR Thermal Break	1" (25)	1.4 (0.20)	-	85 (5.3)	-
9	Stainless Steel Shelf Angle	3/8" (10)	118 (17)	-	500 (8000)	0.12 (500)
10	Steel Bolts	1/2" (13) Ø	347 (50)	-	489 (7830)	0.12 (500)
11	Air Gap ²	1" (25)	-	R-0.9 (0.16 RSI)	0.075 (1.2)	0.24 (1000)
12	Brick Veneer	3 5/8" (92)	5.4 (0.78)	-	120 (1920)	0.19 (720)
13	Concrete Slab	8" (203)	12.5 (1.8)	-	140 (2250)	0.20 (850)
14	Exterior Film ¹	-	-	R-0.2 (0.03 RSI)	-	-

¹ Value selected from table 1, p. 26.1 of 2009 ASHRAE Handbook – Fundamentals depending on surface orientation

² The thermal conductivity of air spaces was found using ISO 100077-2

Detail 5.2.50

Exterior and Interior Insulated Wall Assembly with Stainless Steel Spaced Shelf Angle Without Flashing & Brick Ties Supporting Brick Veneer – Intermediate Floor Intersection

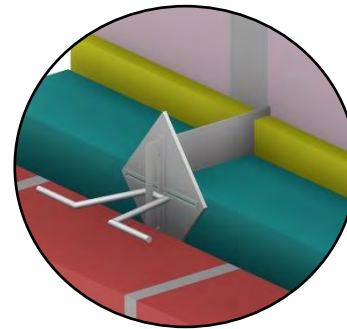
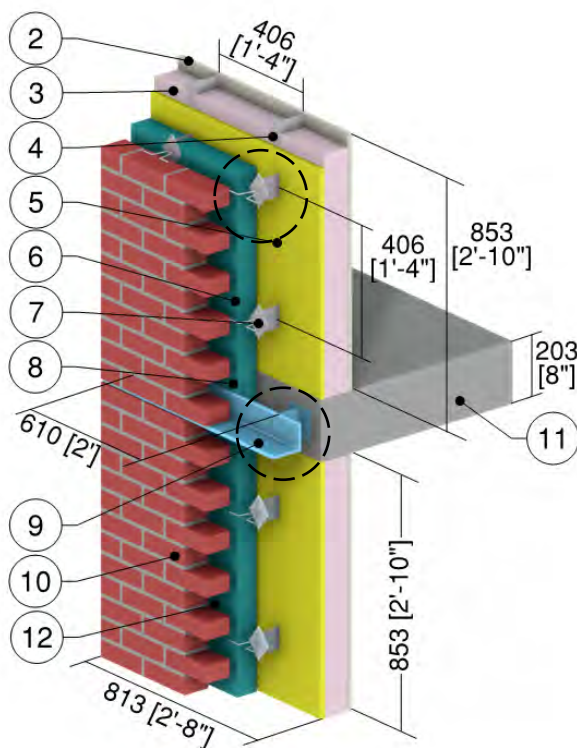

Brick Tie Detail

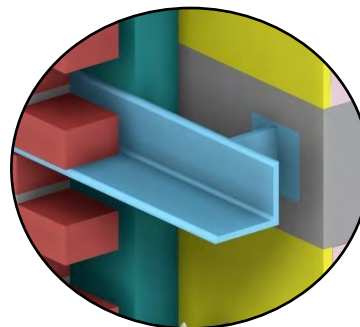

Shelf Angle Detail

ID	Component	Thickness Inches (mm)	Conductivity Btu·in / ft ² ·hr·°F (W/m K)	Nominal Resistance hr·ft ² ·°F/Btu (m ² K/W)	Density lb/ft ³ (kg/m ³)	Specific Heat Btu/lb·°F (J/kg K)
1	Interior Film ¹	-	-	R-0.6 to R-0.9 (0.11 RSI to 0.16 RSI)	-	-
2	Gypsum Board	1/2" (13)	1.1 (0.16)	R-0.5 (0.08 RSI)	50 (800)	0.26 (1090)
3	Fiberglass Batt Insulation	3 5/8" (92)	0.30 (0.044)	R-12 (2.1 RSI)	0.9 (14)	0.17 (710)
4	3 5/8" x 1 5/8" Steel Studs with Top and Bottom Tracks	18 Gauge	430 (62)	-	489 (7830)	0.12 (500)
5	Exterior Sheathing	1/2" (13)	1.1 (0.16)	R-0.5 (0.08 RSI)	50 (800)	0.26 (1090)
6	Exterior Insulation	Varies	-	R-5 to R-25 (0.88 RSI to 4.4 RSI)	1.8 (28)	0.29 (1220)
7	Brick Ties	14 Gauge	347 (50)	-	489 (7830)	0.12 (500)
8	Exterior Insulation Behind Shelf Angle	Varies	-	R-5 to R-25 (0.88 RSI to 4.4 RSI)	1.8 (28)	0.29 (1220)
9	Stainless Steel Spaced Shelf Angle	3/8" (10)	118 (17)	-	500 (8000)	0.12 (500)
10	Brick Veneer	3 5/8" (92)	5.4 (0.78)	-	120 (1920)	0.19 (720)
11	Concrete Slab	8" (203)	12.5 (1.8)	-	140 (2250)	0.20 (850)
12	Air Gap	1" (25)	-	R-0.9 (0.16 RSI)	0.075 (1.2)	0.24 (1000)
13	Exterior Film ¹	-	-	R-0.2 (0.03 RSI)	-	-

¹ Value selected from table 1, p. 26.1 of 2009 ASHRAE Handbook – Fundamentals depending on surface orientation

Detail 5.2.51

Exterior Insulated 6" x 1 5/8" Steel Stud (16" o.c.) Wall Assembly with U-Kon ND 0-33 Bracket and Vertical Rail System Supporting Metal Cladding – Intermediate Floor Intersection

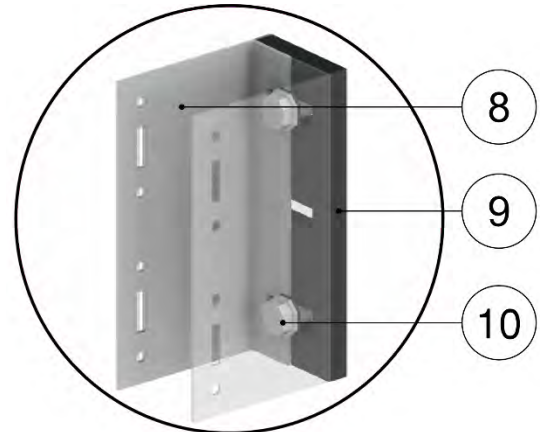
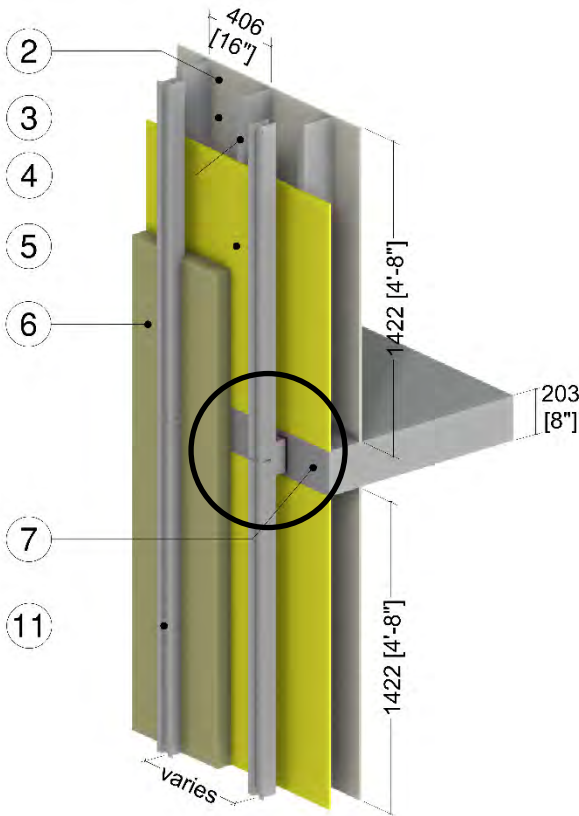

Bracket Detail

Exterior Insulation Thickness for Bracket Sizes

Bracket Size	Exterior Insulation Thickness in (mm)
80	3 (76)
100	4 (102)
120	5 (127)
150	6 (152)
250	10 (254)

ID	Component	Thickness Inches (mm)	Conductivity Btu-in / ft ² -hr-°F (W/m K)	Nominal Resistance hr-ft ² -°F/Btu (m ² K/W)	Density lb/ft ³ (kg/m ³)	Specific Heat Btu/lb-°F (J/kg K)
1	Interior Film ¹	-	-	R-0.7 (0.12 RSI)	-	-
2	Gypsum Board	1/2" (13)	1.1 (0.16)	R-0.5 (0.09 RSI)	50 (800)	0.26 (1090)
3	Air in Stud Cavity	6" (152)	-	R-0.9 (0.16 RSI)	0.075 (1.2)	0.24 (1000)
4	6" x 1 5/8" Steel Studs (16" o.c.) with Top and Bottom Tracks	18 Gauge	430 (62)	-	489 (7830)	0.12 (500)
5	Exterior Sheathing	1/2" (13)	1.1 (0.16)	R-0.5 (0.09 RSI)	50 (800)	0.26 (1090)
6	Exterior Mineral Wool Insulation	Varies	0.24 (0.034)	R-12.6 to R-42.0 (2.22 to 7.40 RSI)	4 (64)	0.20 (850)
7	Intermediate Concrete Floor	8 (203)	12.5 (1.8)	-	140 (2250)	0.20 (850)
8	U-Kon ND-033 Bracket	14 to 16 Gauge	118 (17)	-	499 (8000)	0.12 (500)
9	Thermal Isolator	3/8" (10)	0.11 (0.12)	-	-	-
10	Fastener	3/8" (10) Ø	118 (17)	-	499 (8000)	0.12 (500)
11	Vertical Rail	18 Gauge	430 (147)	-	-	-
12	Cladding with vented airspace incorporated into exterior heat transfer coefficient					
13	Exterior Film ¹	-	-	R-0.7 (0.12 RSI)	-	-

¹ Value selected from table 1, p. 26.1 of 2009 ASHRAE Handbook – Fundamentals depending on surface orientation

Detail 5.3.1

Exterior Insulated 3 5/8" x 1 5/8" Steel Stud (16" o.c.) Drained EIFS Wall Assembly – Window and Intermediate Floor Intersection

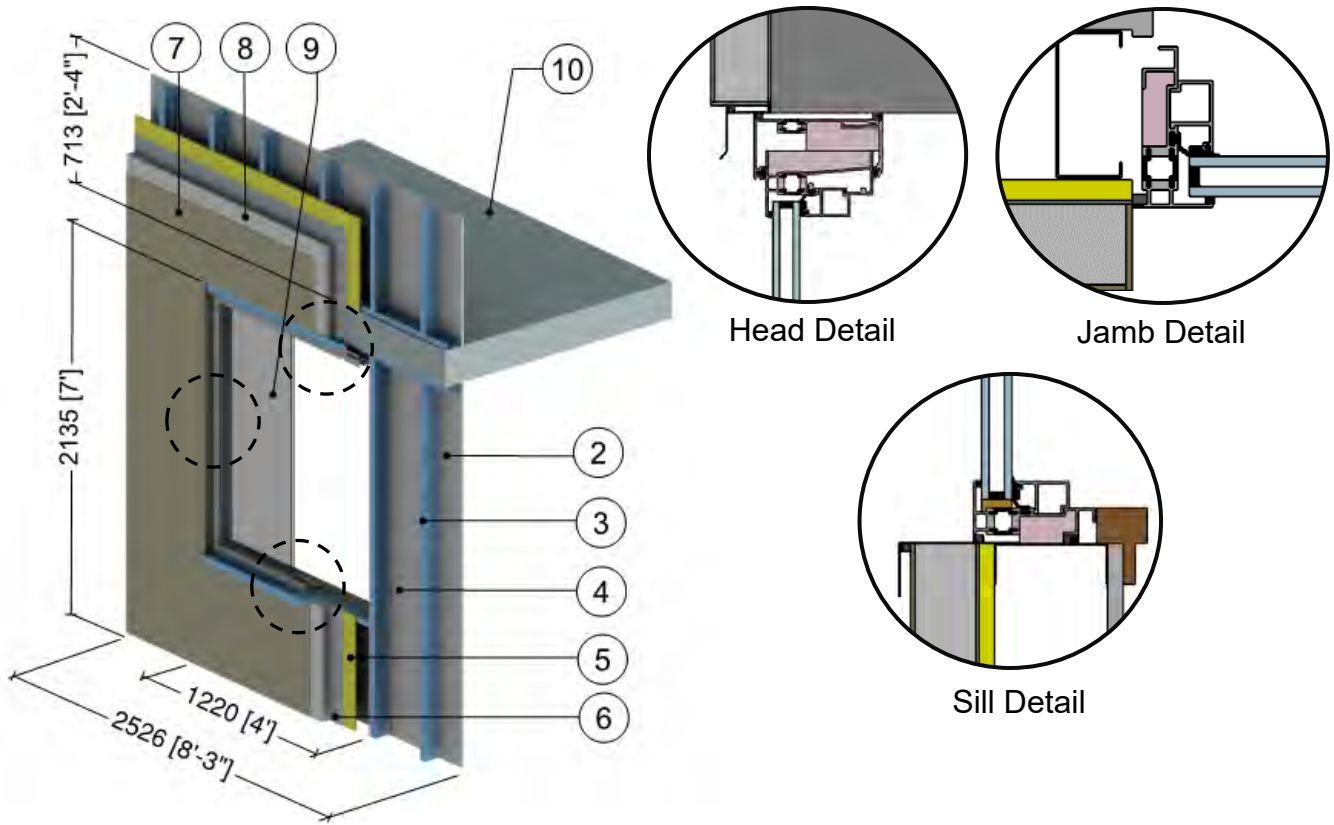

ID	Component	Thickness Inches (mm)	Conductivity Btu-in / ft ² ·hr·°F (W/m K)	Nominal Resistance hr·ft ² ·°F/Btu (m ² K/W)	Density lb/ft ³ (kg/m ³)	Specific Heat Btu/lb·°F (J/kg K)
1	Interior Films ¹	-	-	R-0.6 to R-1.1 (0.11 RSI to 0.20 RSI)	-	-
2	Gypsum Board	1/2" (13)	1.1 (0.16)	R-0.5 (0.08 RSI)	50 (800)	0.26 (1090)
3	3 5/8" x 1 5/8" Steel Studs (16" o.c.) with Top and Bottom Tracks	18 Gauge	430 (62)	-	489 (7830)	0.12 (500)
4	Air in Stud Cavity	3 5/8" (92)	-	R-0.9 (0.16 RSI)	0.075 (1.2)	0.24 (1000)
5	Exterior Sheathing	1/2" (13)	1.1 (0.16)	R-0.5 (0.08 RSI)	50 (800)	0.26 (1090)
6	Weather Resistive Barrier with Adhesive	-	-	-	-	-
7	Lamina	1/8" (4)	6 (0.9)	R-0.04 (0.01 RSI)	120 (1922)	0.20 (850)
8	Insulation Board	Varies	0.27 (0.039)	R-7.5 to R-15 (1.32 RSI to 2.64 RSI)	1 (16)	0.35 (1470)
9	5' (1.5m) x 6' (1.8m) Aluminum window: double glazed & thermally broken ² , double glazed IGU U _{IGU} = 0.32 BTU/hr.ft ² ·°F (1.82 W/m ² K)					
10	Concrete Slab	8" (203)	12.5 (1.8)	-	140 (2250)	0.20 (850)
11	Exterior Film ¹	-	-	R-0.2 (0.03 RSI)	-	-

¹ Value selected from table 1, p. 26.1 of 2009 ASHRAE Handbook – Fundamentals depending on surface orientation

² The thermal conductivity of air spaces within framing was found using ISO 100077-2

Detail 5.3.2

Exterior and Interior Insulated 3 5/8" x 1 5/8" Steel Stud (16" o.c.) Drained EIFS Wall Assembly with R-12 Batt Insulation in Stud Cavity – Window and Intermediate Floor Intersection

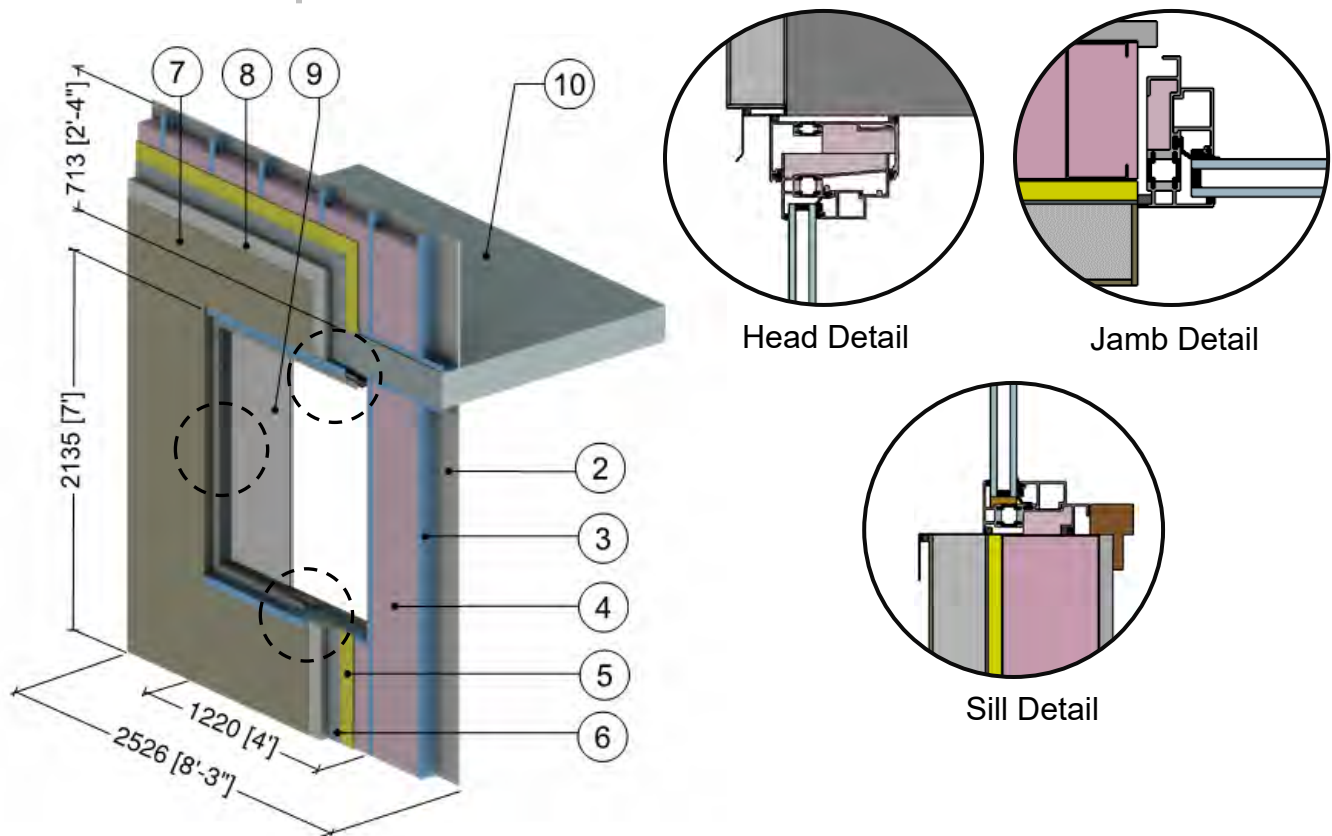

ID	Component	Thickness Inches (mm)	Conductivity Btu-in / ft ² ·hr·°F (W/m K)	Nominal Resistance hr·ft ² ·°F/Btu (m ² K/W)	Density lb/ft ³ (kg/m ³)	Specific Heat Btu/lb·°F (J/kg K)
1	Interior Films ¹	-	-	R-0.6 to R-1.1 (0.11 RSI to 0.20 RSI)	-	-
2	Gypsum Board	1/2" (13)	1.1 (0.16)	R-0.5 (0.08 RSI)	50 (800)	0.26 (1090)
3	3 5/8" x 1 5/8" Steel Studs (16" o.c.) with Top and Bottom Tracks	18 Gauge	430 (62)	-	489 (7830)	0.12 (500)
4	Fiberglass Batt Insulation	3 5/8" (92)	0.31 (0.044)	R-12 (2.1 RSI)	0.9 (1.1)	0.17 (710)
5	Exterior Sheathing	1/2" (13)	1.1 (0.16)	R-0.5 (0.08 RSI)	50 (800)	0.26 (1090)
6	Weather Resistant Barrier with Adhesive	-	-	-	-	-
7	Lamina	1/8" (4)	6 (0.9)	R-0.04 (0.01 RSI)	120 (1922)	0.20 (850)
8	Insulation Board	Varies	0.27 (0.039)	R-7.5 to R-15 (1.32 RSI to 2.64 RSI)	1 (16)	0.35 (1470)
9	5' (1.5m) x 6' (1.8m) Aluminum window: double glazed & thermally broken ² , double glazed IGU U _{IGU} = 0.32 BTU/hr.ft ² ·°F (1.82 W/m ² K)					
10	Concrete Slab	8" (203)	12 (1.8)	-	140 (2250)	0.20 (850)
11	Exterior Film ¹	-	-	R-0.2 (0.03 RSI)	-	-

¹ Value selected from table 1, p. 26.1 of 2009 ASHRAE Handbook – Fundamentals depending on surface orientation

² The thermal conductivity of air spaces within framing was found using ISO 100077-2

Detail 5.3.3

Exterior Insulated 3 5/8" x 1 5/8" Steel Stud (16" o.c.) Drained EIFS Wall Assembly – Window with Aerogel and Intermediate Floor Intersection

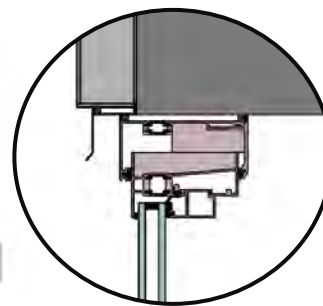
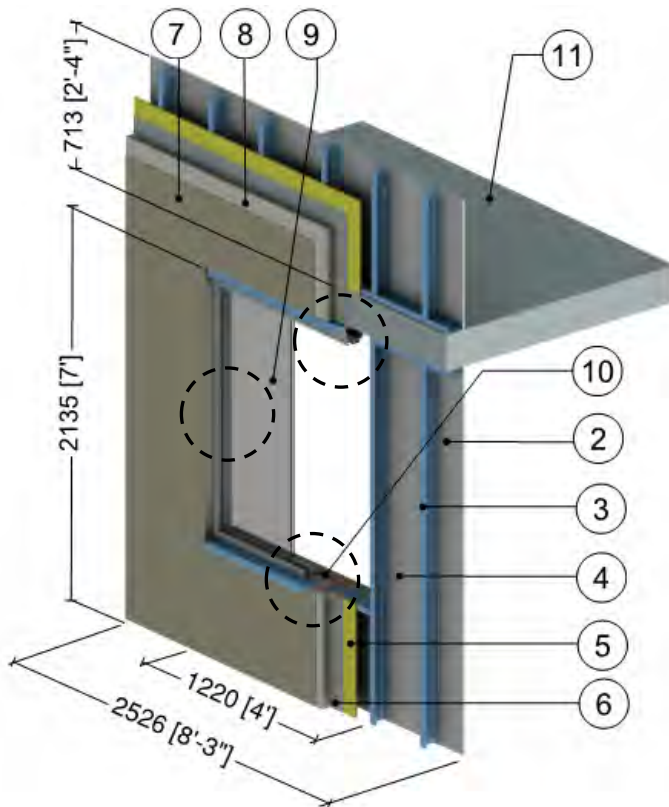

Head Detail

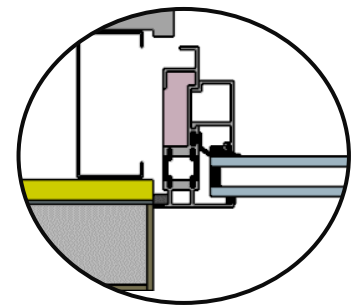

Jamb Detail

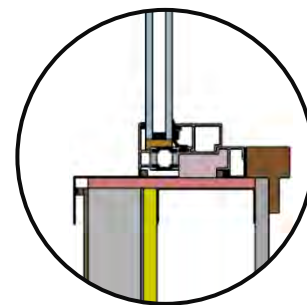

Sill Detail

ID	Component	Thickness Inches (mm)	Conductivity Btu-in / ft ² ·hr·°F (W/m K)	Nominal Resistance hr·ft ² ·°F/Btu (m ² K/W)	Density lb/ft ³ (kg/m ³)	Specific Heat Btu/lb·°F (J/kg K)
1	Interior Films ¹	-	-	R-0.6 to R-1.1 (0.11 RSI to 0.20 RSI)	-	-
2	Gypsum Board	1/2" (13)	1.1 (0.16)	R-0.5 (0.08 RSI)	50 (800)	0.26 (1090)
3	3 5/8" x 1 5/8" Steel Studs (16" o.c.) with Top and Bottom Tracks	18 Gauge	430 (62)	-	489 (7830)	0.12 (500)
4	Air in Stud Cavity	3 5/8" (92)	-	R-0.9 (0.16 RSI)	0.075 (1.2)	0.24 (1000)
5	Exterior Sheathing	1/2" (13)	1.1 (0.16)	R-0.5 (0.08 RSI)	50 (800)	0.26 (1090)
6	Weather Resistive Barrier with Adhesive	-	-	-	-	-
7	Lamina	1/8" (4)	6 (0.9)	R-0.04 (0.01 RSI)	120 (1922)	0.20 (850)
8	Insulation Board	Varies	0.27 (0.039)	R-7.5 to R-15 (1.32 RSI to 2.64 RSI)	1 (16)	0.35 (1470)
9	5' (1.5m) x 6' (1.8m) Aluminum window: double glazed & thermally broken ² , double glazed IGU U _{IGU} = 0.32 BTU/hr.ft ² ·°F (1.82 W/m ² K)					
10	Aerogel Blanket	3/8" (10)	0.086 (0.015)	R-3.8 (0.67 RSI)	-	-
11	Concrete Slab	8" (203)	12.5 (1.8)	-	140 (2250)	0.20 (850)
12	Exterior Film ¹	-	-	R-0.2 (0.03 RSI)	-	-

¹ Value selected from table 1, p. 26.1 of 2009 ASHRAE Handbook – Fundamentals depending on surface orientation

² The thermal conductivity of air spaces within framing was found using ISO 100077-2

Detail 5.3.4

Exterior and Interior Insulated 3 5/8" x 1 5/8" Steel Stud (16" o.c.) Drained EIFS Wall Assembly with R-12 Batt Insulation in Stud Cavity – Window with Aerogel and Floor Slab Intersection

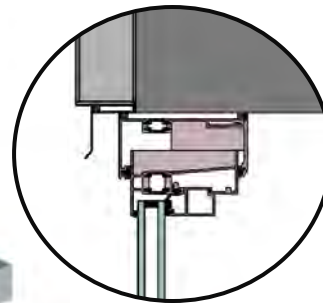
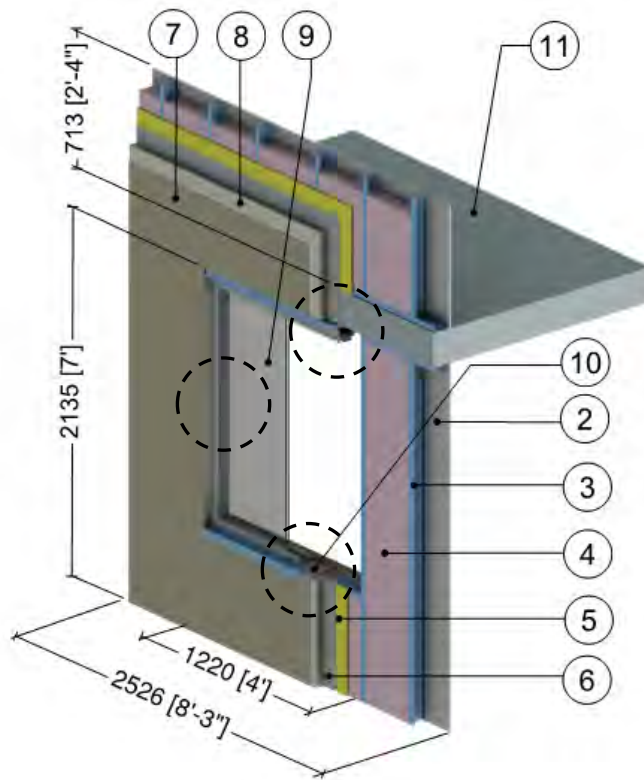

Head Detail

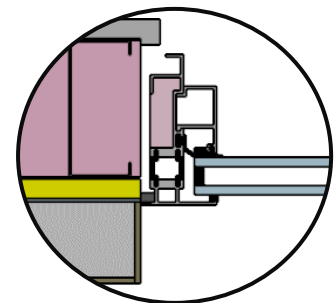

Jamb Detail

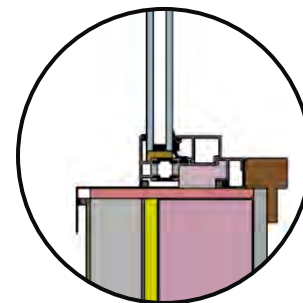

Sill Detail

ID	Component	Thickness Inches (mm)	Conductivity Btu-in / ft ² ·hr·°F (W/m K)	Nominal Resistance hr·ft ² ·°F/Btu (m ² K/W)	Density lb/ft ³ (kg/m ³)	Specific Heat Btu/lb·°F (J/kg K)
1	Interior Films ¹	-	-	R-0.6 to R-1.1 (0.11 RSI to 0.20 RSI)	-	-
2	Gypsum Board	1/2" (13)	1.1 (0.16)	R-0.5 (0.08 RSI)	50 (800)	0.26 (1090)
3	3 5/8" x 1 5/8" Steel Studs (16" o.c.) with Top and Bottom Tracks	18 Gauge	430 (62)	-	489 (7830)	0.12 (500)
4	Fiberglass Batt Insulation	3 5/8" (92)	0.31 (0.044)	R-12 (2.1 RSI)	0.9 (1.1)	0.17 (710)
5	Exterior Sheathing	1/2" (13)	1.1 (0.16)	R-0.5 (0.08 RSI)	50 (800)	0.26 (1090)
6	Weather Resistive Barrier with Adhesive	-	-	-	-	-
7	Lamina	1/8" (4)	6 (0.9)	R-0.04 (0.01 RSI)	120 (1922)	0.20 (850)
8	Insulation Board	Varies	0.27 (0.039)	R-7.5 (1.32 RSI) to R-15 (2.64 RSI)	1 (16)	0.35 (1470)
9	5' (1.5m) x 6' (1.8m) Aluminum window: double glazed & thermally broken ² , double glazed IGU U _{IGU} = 0.32 BTU/hr.ft ² ·°F (1.82 W/m ² K)					
10	Aerogel Blanket	3/8" (10)	0.086 (0.015)	R-3.8 (0.67 RSI)	-	-
11	Concrete Slab	8" (203)	12.5 (1.8)	-	140 (2250)	0.20 (850)
12	Exterior Film ¹	-	-	R-0.2 (0.03 RSI)	-	-

¹ Value selected from table 1, p. 26.1 of 2009 ASHRAE Handbook – Fundamentals depending on surface orientation

² The thermal conductivity of air spaces within framing was found using ISO 100077-2

Detail 5.3.5

Exterior Insulated 3 5/8" x 1 5/8" Steel Stud (16" o.c.) Wall Assembly with Horizontal Z-Girts (24" o.c.) Supporting Metal Cladding – Window & Intermediate Floor Intersection

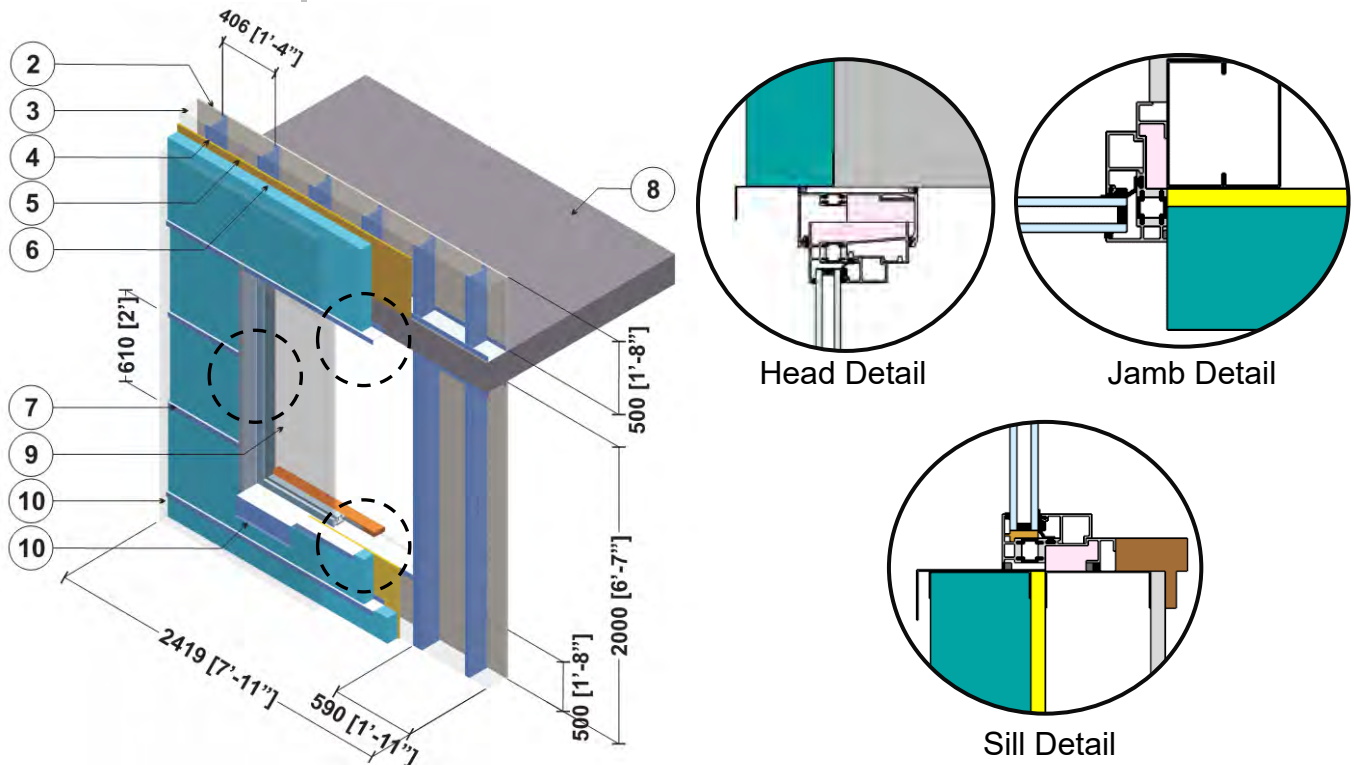

ID	Component	Thickness Inches (mm)	Conductivity Btu-in / ft ² -hr-°F (W/m K)	Nominal Resistance hr-ft ² -°F/Btu (m ² K/W)	Density lb/ft ³ (kg/m ³)	Specific Heat Btu/lb-°F (J/kg K)
1	Interior Film ¹	-	-	R-0.6 to R-0.9 (0.11 RSI to 0.16 RSI)	-	-
2	Gypsum Board	1/2" (13)	1.1 (0.16)	R-0.5 (0.08 RSI)	50 (800)	0.26 (1090)
3	Air in Stud Cavity	3 5/8" (92)	-	R-0.9 (0.16 RSI)	0.075 (1.2)	0.24 (1000)
4	3 5/8" x 1 5/8" Steel Studs with Top and Bottom Tracks	18 Gauge	430 (62)	-	489 (7830)	0.12 (500)
5	Exterior Sheathing	1/2" (13)	1.1 (0.16)	R-0.5 (0.08 RSI)	50 (800)	0.26 (1090)
6	Exterior Insulation	Varies	-	R-5 to R-25 (0.88 RSI to 4.4 RSI)	1.8 (28)	0.29 (1220)
7	Horizontal Z-Girts w/ 1 1/2" Flange	18 Gauge	430 (62)	-	489 (7830)	0.12 (500)
8	Concrete Slab	8" (203)	12.5 (1.8)	-	140 (2250)	0.20 (850)
9	5' (1.5m) x 6' (1.8m) Aluminum window: double glazed & thermally broken ² , double glazed IGU U _{IGU} = 0.32 BTU/hr.ft ² .°F (1.82 W/m ² K)					
10	Metal cladding with 1/2" (13mm) vented air space is incorporated into exterior heat transfer coefficient, sill flashing & interior finish materials					
11	Exterior Film ¹	-	-	R-0.2 to R-0.7 (0.03 RSI to 0.12 RSI)	-	-

¹ Value selected from table 1, p. 26.1 of 2009 ASHRAE Handbook – Fundamentals depending on surface orientation

² The thermal conductivity for air spaces within window framing was found using ISO 10077-2

Detail 5.3.6

Exterior and Interior Insulated 3 5/8" x 1 5/8" Steel Stud (16" o.c.) Wall Assembly with Horizontal Z-girts (24" o.c.) Supporting Metal Cladding and R-12 Batt Insulation in Stud Cavity – Window and Intermediate Floor Intersection

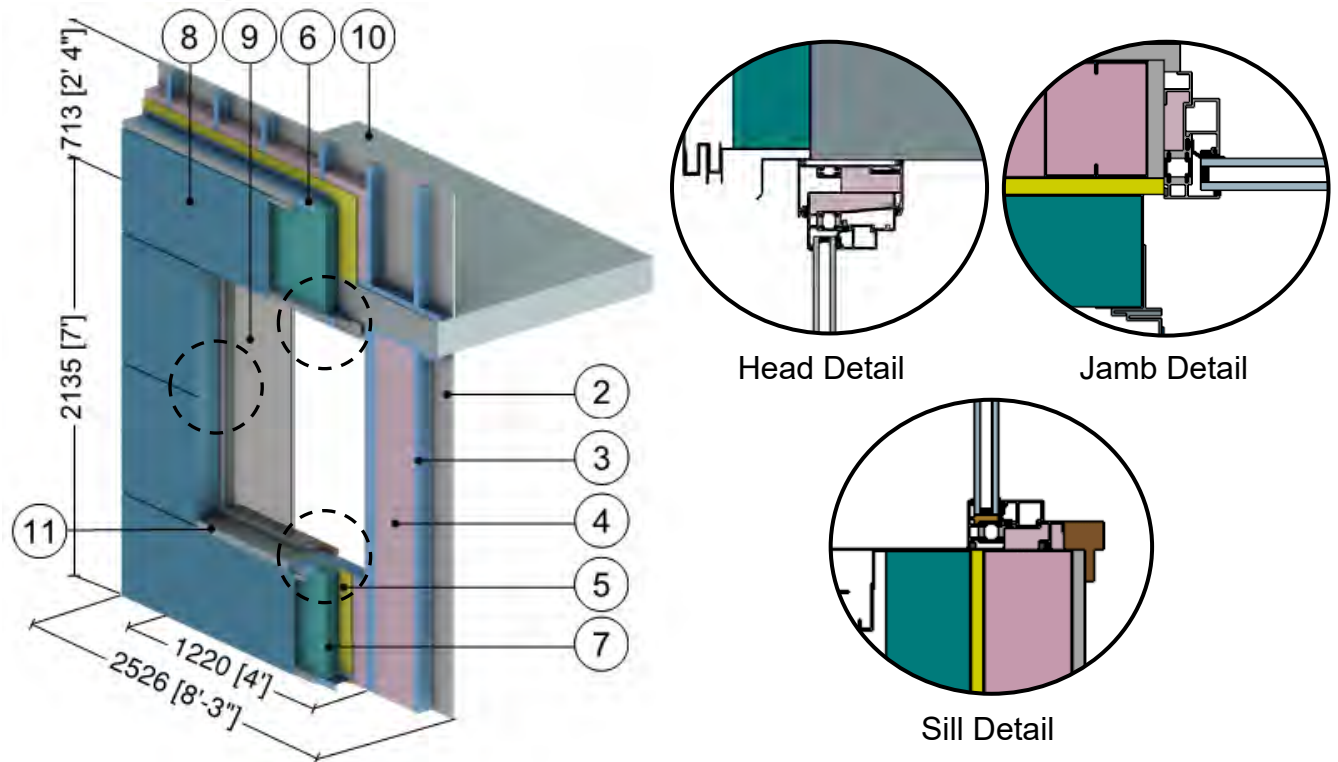

ID	Component	Thickness Inches (mm)	Conductivity Btu-in / ft ² ·hr·°F (W/m K)	Nominal Resistance hr·ft ² ·°F/Btu (m ² K/W)	Density lb/ft ³ (kg/m ³)	Specific Heat Btu/lb·°F (J/kg K)
1	Interior Film ¹	-	-	R-0.6 to R-0.7 (0.11 RSI to 0.12 RSI)	-	-
2	Gypsum Board	1/2" (13)	1.1 (0.16)	R-0.5 (0.08 RSI)	50 (800)	0.26 (1090)
3	3 5/8" x 1 5/8" Steel Studs with Top Tracks	18 Gauge	430 (62)	-	489 (7830)	0.12 (500)
4	Fiberglass Batt Insulation	3 5/8" (92)	0.31 (0.044)	R-12 (2.1 RSI)	0.9 (14)	0.17 (710)
5	Exterior Sheathing	1/2" (13)	1.1 (0.16)	R-0.5 (0.08 RSI)	50 (800)	0.26 (1090)
6	Horizontal Z-girts w/ 1 1/2" Flange	18 Gauge	430 (62)	-	489 (7830)	0.12 (500)
7	Exterior Insulation	Varies	-	R-10 to R-15 (1.76 RSI to 2.64 RSI)	1.8 (28)	0.29 (1220)
8	Metal Cladding with 1/2" vented airspace incorporated into exterior heat transfer coefficient					
9	5' (1.5m) x 6' (1.8m) Aluminum window: double glazed & thermally broken ² , double glazed IGU U _{IGU} = 0.32 BTU/hr.ft ² ·°F (1.82 W/m ² K)					
10	Concrete Slab	8" (203)	12.5 (1.8)	-	140 (2250)	0.20 (850)
11	Aluminum Flashing	18 Gauge	1110 (160)	-	171(2739)	0.21 (900)
12	Exterior Film ¹	-	-	R-0.2 to R-0.7 (0.03 RSI to 0.12 RSI)	-	-

¹ Value selected from table 1, p. 26.1 of 2009 ASHRAE Handbook – Fundamentals depending on surface orientation

² The thermal conductivity for air spaces within window framing was found using ISO 10077-2

Detail 5.3.7

Exterior and Interior Insulated 3 5/8" x 1 5/8" Steel Stud (16" o.c.) Wall Assembly with Vertical Z Girts (16" o.c.) Supporting Stucco Cladding and R-12 Batt Insulation in Stud Cavity – Window and Intermediate Floor Intersection

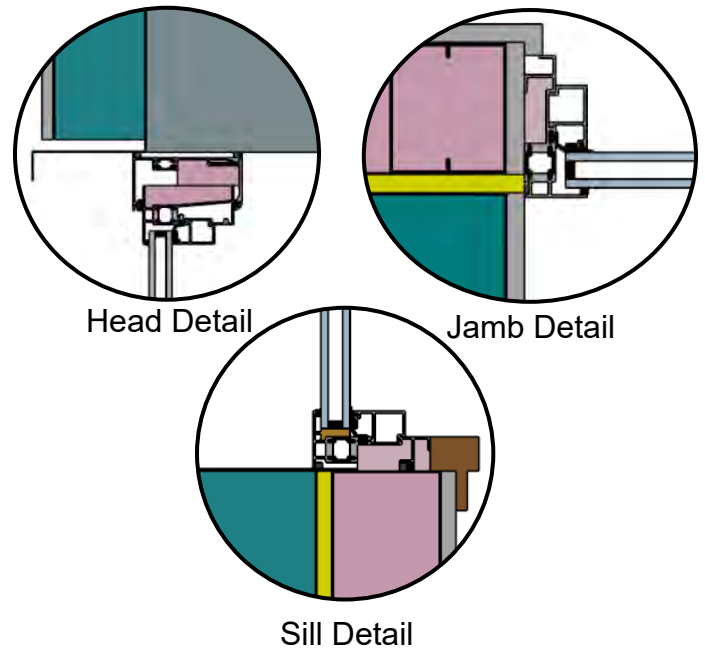
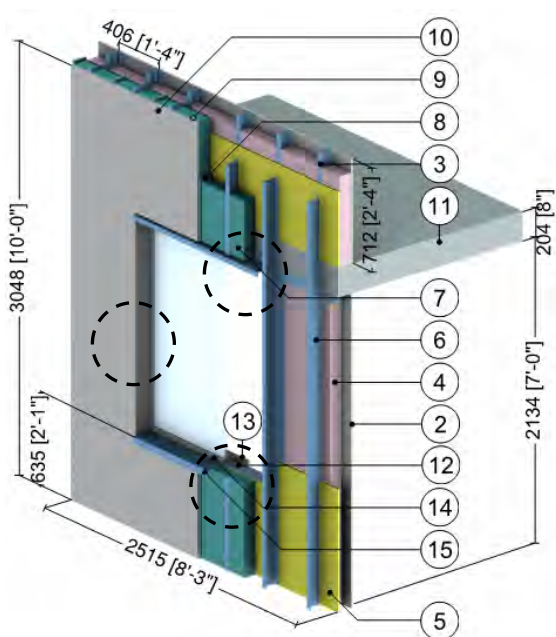

ID	Component	Thickness Inches (mm)	Conductivity Btu-in / ft ² ·hr·°F (W/m K)	Nominal Resistance hr·ft ² ·°F/Btu (m ² K/W)	Density lb/ft ³ (kg/m ³)	Specific Heat Btu/lb·°F (J/kg K)
1	Interior Film ¹	-	-	R-0.6 to R-1.1 (0.11 RSI to 0.20 RSI)	-	-
2	Gypsum Board	1/2" (13)	1.1 (0.16)	R-0.5 (0.08 RSI)	50 (800)	0.26 (1090)
3	3 5/8" x 1 5/8" Steel Studs with Top and Bottom Tracks	18 Gauge	430 (62)	-	489 (7830)	0.12 (500)
4	Fiberglass Batt Insulation	3 5/8" (92)	0.31 (0.044)	R-12 (2.1 RSI)	0.9 (14)	0.17 (710)
5	Exterior Sheathing	1/2" (13)	1.1 (0.16)	R-0.5 (0.08 RSI)	50 (800)	0.26 (1090)
6	Vertical Z-Girts with 1 1/2" Flange	18 Gauge	430 (62)	-	489 (7830)	0.12 (500)
7	Exterior Insulation	Varies	-	R-10 to R-15 (1.76 RSI to 2.64 RSI)	1.8 (28)	0.29 (1220)
8	Rigid Insulation Bracing	Varies	0.2 (0.29)	-	1.8 (28)	0.29 (1220)
9	Rainscreen Cavity	1/2" (13)	-	R-0.5 (0.09 RSI)	0.075 (1.2)	0.24 (1000)
10	Stucco Cement with Breather Board	1/2" (13)	6 (0.9)	R-0.1 (0.01 RSI)	120 (1922)	0.20 (850)
11	Concrete Slab	8" (203)	12.5 (1.8)	-	140 (2250)	0.20 (850)
12	Metal sheet connected to studs	18 Gauge	430 (62)	-	489 (7830)	0.12 (500)
13	Wood Sill	1.5" (38)	0.69 (0.10)	-	31 (500)	0.45 (1880)
14	5' (1.5m) x 6' (1.8m) Aluminum window: double glazed & thermally broken ² , double glazed IGU U _{IGU} = 0.32 BTU/hr.ft ² ·°F (1.82 W/m ² K)					
15	Aluminum Flashing	14 Gauge	1110 (160)	-	171 (2739)	0.21 (900)
16	Exterior Film ¹	-	-	R-0.2 (0.03 RSI)	-	-

¹ Value selected from table 1, p. 26.1 of 2009 ASHRAE Handbook – Fundamentals depending on surface orientation

² The thermal conductivity of air spaces within framing was found using ISO 100077-2

Detail 5.3.8

Interior Insulated Steel Frame Wall Assembly with Brick Cladding – Window Intersection

Detail referenced from work done by Passive House Academy

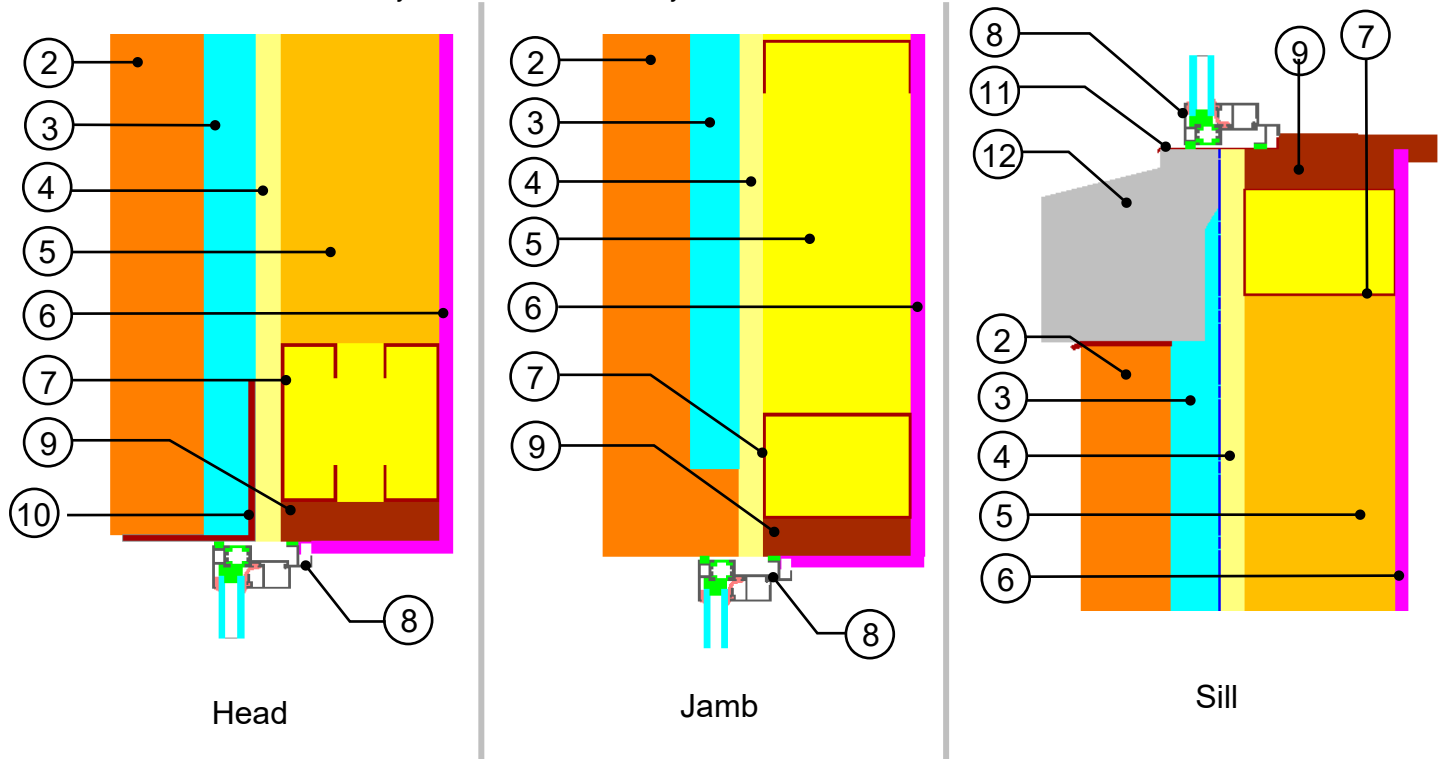

ID	Component	Thickness Inches (mm)	Conductivity Btu-in / ft ² ·hr·°F (W/m K)	Nominal Resistance hr·ft ² ·°F/Btu (m ² K/W)	Density lb/ft ³ (kg/m ³)	Specific Heat Btu/lb·°F (J/kg K)
1	Interior Films ¹	-	-	R-0.74 (0.13 RSI)	-	-
2	Brick	3 5/8" (92)	0.578 (1.0)	R-0.523 (0.092 RSI)	110 (1800)	-
3	Air Cavity	2" (51)	0.132 (0.23)	R-1.261 (0.222 RSI)	-	-
4	Insulation	1" (25)	0.0139 (0.024)	R-6 (1.055 RSI)	-	-
5	Mineral Wool Insulation with Steel Studs	6 3/8" (162)	0.0370 (0.064)	R-14.36 (2.53 RSI)	-	-
6	Gypsum Board	1/2" (13)	0.092 (0.16)	R-0.5 (0.08 RSI)	50 (800)	-
7	Steel Studs	-	27.7 (48)	-	-	-
8	5500 ISOWEB Window	-	-	-	-	-
9	Timber Buck	-	0.006 (0.10)	-	-	-
10	Steel Lintel	-	27.7 (48)	-	-	-
11	Aluminum Sill Pan	-	92.45 (160)	-	-	-
12	Concrete Sill	-	1.4 (2.4)	-	-	-
13	Exterior Film ¹	-	-	R-0.23 (0.04 RSI)	-	-

¹ Value selected from table 1, p. 26.1 of 2009 ASHRAE Handbook – Fundamentals depending on surface orientation

Detail 5.3.9

Interior Insulated Steel Frame Wall Assembly with Brick Cladding – Window Intersection Aligned with Insulation

Detail referenced from work done by Passive House Academy

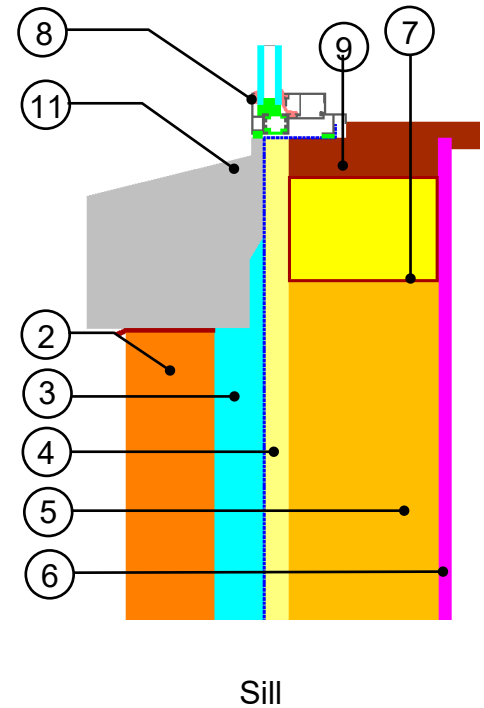
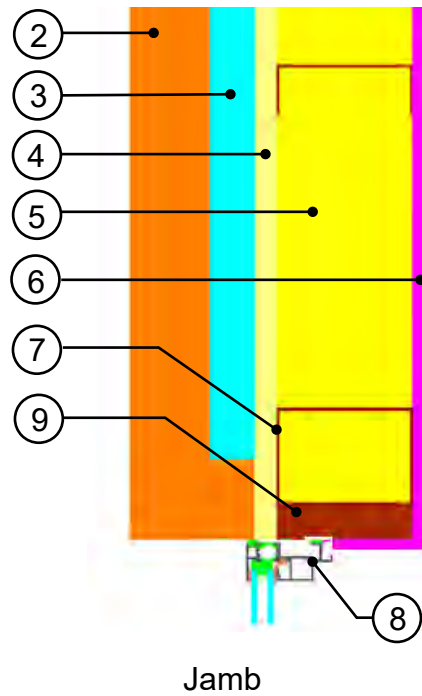
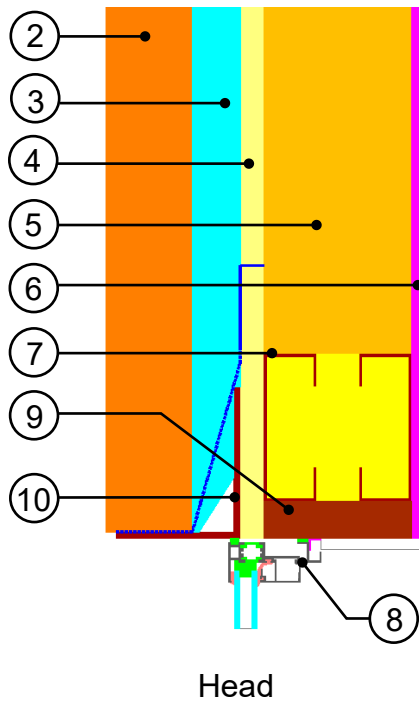

ID	Component	Thickness Inches (mm)	Conductivity Btu·in / ft ² ·hr·°F (W/m K)	Nominal Resistance hr·ft ² ·°F/Btu (m ² K/W)	Density lb/ft ³ (kg/m ³)	Specific Heat Btu/lb·°F (J/kg K)
1	Interior Films ¹	-	-	R-0.74 (0.13 RSI)	-	-
2	Brick	3 5/8" (92)	0.578 (1.0)	R-0.523 (0.092 RSI)	110 (1800)	-
3	Air Cavity	2" (51)	0.132 (0.23)	R-1.261 (0.222 RSI)	-	-
4	Insulation	1" (25)	0.0139 (0.024)	R-6 (1.055 RSI)	-	-
5	Mineral Wool Insulation with Steel Studs	6 3/8" (162)	0.0370 (0.064)	R-14.36 (2.53 RSI)	-	-
6	Gypsum Board	1/2" (13)	0.092 (0.16)	R-0.5 (0.08 RSI)	50 (800)	-
7	Steel Studs	-	27.7 (48)	-	-	-
8	5500 ISOWEB Window	-	-	-	-	-
9	Timber Buck	-	0.006 (0.10)	-	-	-
10	Steel Lintel	-	27.7 (48)	-	-	-
11	Concrete Sill	-	1.4 (2.4)	-	-	-
12	Exterior Film ¹	-	-	R-0.23 (0.04 RSI)	-	-

¹ Value selected from table 1, p. 26.1 of 2009 ASHRAE Handbook – Fundamentals depending on surface orientation

Detail 5.3.10

Exterior Insulated 6" x 1 5/8" Steel Stud (16" o.c.) Wall Assembly with Thermally Isolated Vertical Brackets and Rail System (24" o.c.) Supporting Metal Cladding – Triple Glazed Aluminum Window & Intermediate Floor Intersection with Window Thermal Break Positioned in Steel Framing

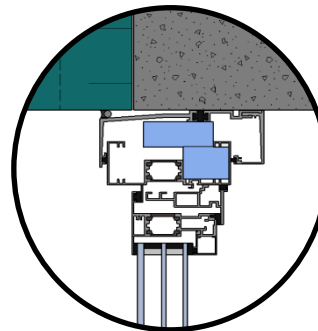
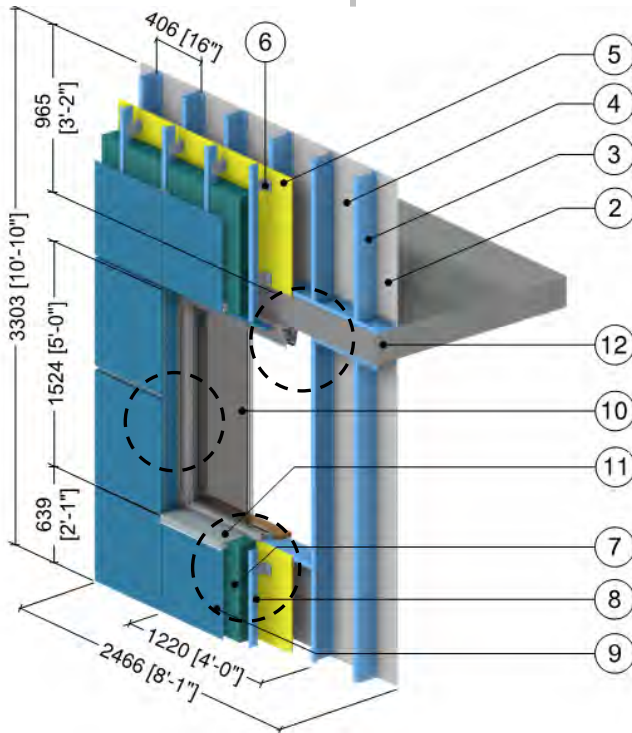

Head Detail

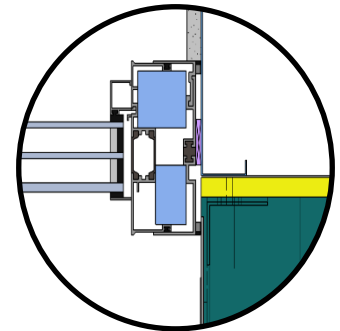

Jamb Detail

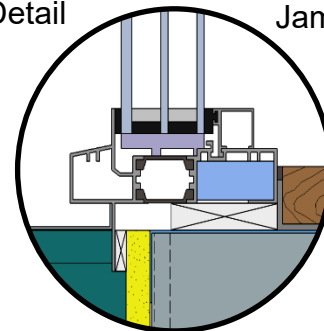

Sill Detail

ID	Component	Thickness Inches (mm)	Conductivity Btu-in / ft ² ·hr·°F (W/m K)	Nominal Resistance hr·ft ² ·°F/Btu (m ² K/W)	Density lb/ft ³ (kg/m ³)	Specific Heat Btu/lb·°F (J/kg K)
1	Interior Film ¹	-	-	R-0.6 to R-1.1 (0.11 RSI to 0.20 RSI)	-	-
2	Gypsum Board	1/2" (13)	1.1 (0.16)	R-0.5 (0.08 RSI)	50 (800)	0.26 (1090)
3	6" x 1 5/8" Steel Studs (16" o.c.) with Top and Bottom Tracks	18 Gauge	430 (62)	-	489 (7830)	0.12 (500)
4	Air in Stud Cavity	6" (152)	-	R-0.9 (0.16 RSI)	0.075 (1.2)	0.24 (1000)
5	Exterior Sheathing	1/2" (13)	1.1 (0.16)	R-0.5 (0.08 RSI)	50 (800)	0.26 (1090)
6	Thermally Isolated Aluminum Bracket	0.09" (2.2)	1110 (160)	-	171 (2739)	0.21 (900)
7	Exterior Insulation	Varies	-	R-10 to R-25 (1.76 RSI to 4.40 RSI)	1.8 (28)	0.29 (1220)
8	Vertical Aluminum L-girt	0.09" (2.2)	1110 (160)	-	171 (2739)	0.21 (900)
9	Generic Cladding with 1/2" (13mm) vented air space is incorporated into exterior heat transfer coefficient					
10	5' (1.5m) x 4' (1.2m) Aluminum window: triple glazed & thermally broken ² , IGU U _{IGU} = 0.14 BTU/hr.ft ² ·°F (0.81 W/m ² K)					
11	Aluminum Flashing	14 Gauge	1110 (160)	-	171 (2739)	0.21 (900)
12	Concrete Floor Slab	8" (203)	12.5 (1.8)	-	140 (2250)	0.20 (850)
13	Exterior Film ¹	-	-	R-0.2 (0.03 RSI) to R-0.7 (0.12 RSI)	-	-

¹ Value selected from table 1, p. 26.1 of 2009 ASHRAE Handbook – Fundamentals depending on surface orientation

² The thermal conductivity of air spaces within framing was found using ISO 100077-2



Detail 5.3.11

Exterior and Interior Insulated 6" x 1 5/8" Steel Stud (16" o.c.) Wall Assembly with Thermally Isolated Vertical Brackets and Rail System (24" o.c.) Supporting Metal Cladding and R-19 Batt Insulation in Stud Cavity – Triple Glazed Aluminum Window & Intermediate Floor Intersection with Window Thermal Break Positioned in Steel Framing

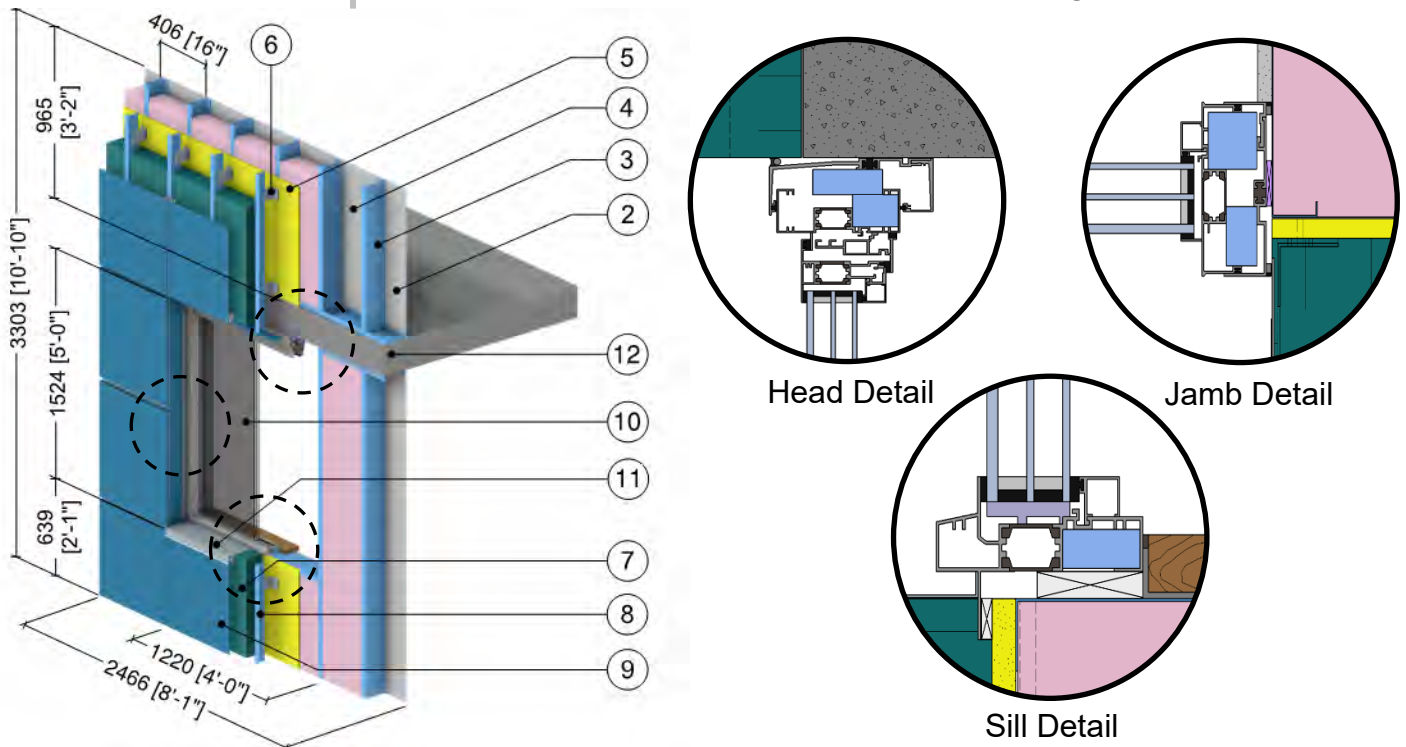

ID	Component	Thickness Inches (mm)	Conductivity Btu-in / ft ² ·hr·°F (W/m K)	Nominal Resistance hr·ft ² ·°F/Btu (m ² K/W)	Density lb/ft ³ (kg/m ³)	Specific Heat Btu/lb·°F (J/kg K)
1	Interior Film ¹	-	-	R-0.6 to R-1.1 (0.11 RSI to 0.20 RSI)	-	-
2	Gypsum Board	1/2" (13)	1.1 (0.16)	R-0.5 (0.08 RSI)	50 (800)	0.26 (1090)
3	6" x 1 5/8" Steel Studs (16" o.c.) with Top and Bottom Tracks	18 Gauge	430 (62)	-	489 (7830)	0.12 (500)
4	Fiberglas Batt Insulation	6" (152)	0.32 (0.046)	R-19 (3.35 RSI)	0.9 (1.1)	0.17 (710)
5	Exterior Sheathing	1/2" (13)	1.1 (0.16)	R-0.5 (0.08 RSI)	50 (800)	0.26 (1090)
6	Thermally Isolated Aluminum Bracket	0.09" (2.2)	1110 (160)	-	171 (2739)	0.21 (900)
7	Exterior Insulation	Varies	-	R-10 to R-25 (1.76 RSI to 4.40 RSI)	1.8 (28)	0.29 (1220)
8	Vertical Aluminum L-girt	0.09" (2.2)	1110 (160)	-	171 (2739)	0.21 (900)
9	Generic Cladding with 1/2" (13mm) vented air space is incorporated into exterior heat transfer coefficient					
10	5' (1.5m) x 4' (1.2m) Aluminum window: triple glazed & thermally broken, IGU U _{IGU} = 0.14 BTU/hr.ft ² ·°F (0.81 W/m ² K) ²					
11	Aluminum Flashing	14 Gauge	1110 (160)	-	171 (2739)	0.21 (900)
12	Concrete Floor Slab	8" (203)	12.5 (1.8)	-	140 (2250)	0.20 (850)
13	Exterior Film ¹	-	-	R-0.2 (0.03 RSI) to R-0.7 (0.12 RSI)	-	-

¹ Value selected from table 1, p. 26.1 of 2009 ASHRAE Handbook – Fundamentals depending on surface orientation

² The thermal conductivity of air spaces within framing was found using ISO 100077-2



Detail 5.3.12

Exterior Insulated 6" x 1 5/8" Steel Stud (16" o.c.) Wall Assembly with Thermally Isolated Vertical Brackets and Rail System (24" o.c.) Supporting Metal Cladding – Triple Glazed Aluminum Curtain Wall & Intermediate Floor Intersection with Window Thermal Break Positioned in the Exterior Insulation

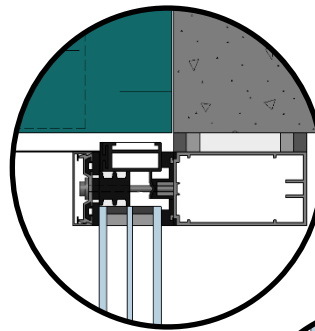
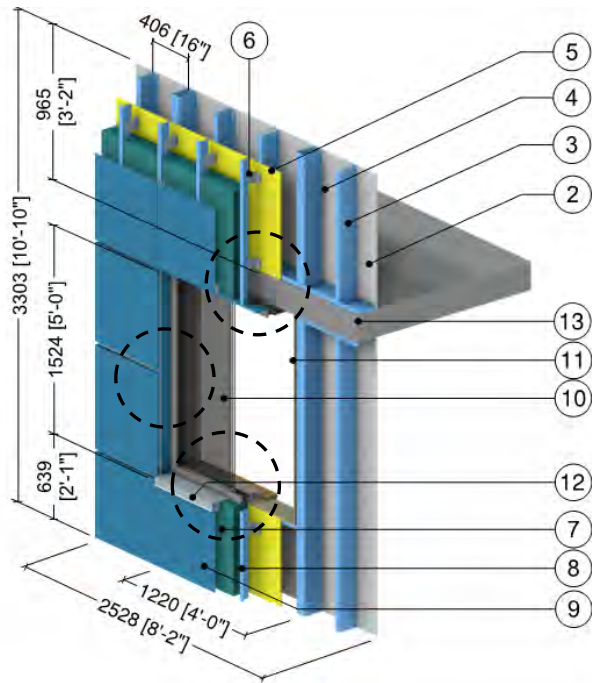

Head Detail

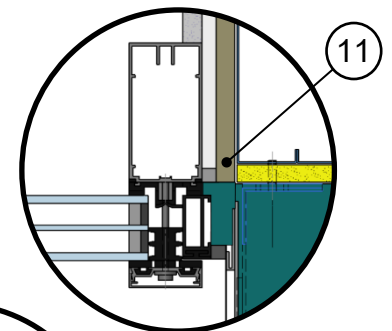

Jamb Detail

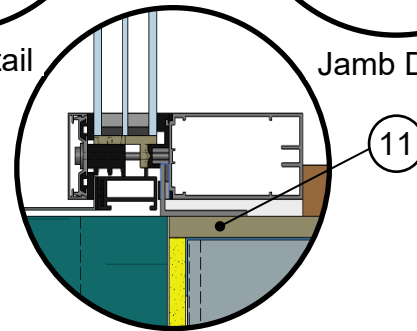

Sill Detail

ID	Component	Thickness Inches (mm)	Conductivity Btu-in / ft ² -hr-°F (W/m K)	Nominal Resistar hr-ft ² -°F/Btu (m ² K/W)	Sill Detail Density lb/ft ³ (kg/m ³)	Specific Heat Btu/lb-°F (J/kg K)
1	Interior Film ¹	-	-	R-0.6 to R-1.1 (0.11 RSI to 0.20 RSI)	-	-
2	Gypsum Board	1/2" (13)	1.1 (0.16)	R-0.5 (0.08 RSI)	50 (800)	0.26 (1090)
3	6" x 1 5/8" Steel Studs (16" o.c.) with Top and Bottom Tracks	18 Gauge	430 (62)	-	489 (7830)	0.12 (500)
4	Air in Stud Cavity	6" (152)	-	R-0.9 (0.16 RSI)	0.075 (1.2)	0.24 (1000)
5	Exterior Sheathing	1/2" (13)	1.1 (0.16)	R-0.5 (0.08 RSI)	50 (800)	0.26 (1090)
6	Thermally Isolated Aluminum Bracket	0.09" (2.2)	1110 (160)	-	171 (2739)	0.21 (900)
7	Exterior Insulation	Varies	-	R-10 to R-25 (1.76 RSI to 4.40 RSI)	1.8 (28)	0.29 (1220)
8	Vertical Aluminum L-girt	0.09" (2.2)	1110 (160)	-	171 (2739)	0.21 (900)
9	Generic Cladding with 1/2" (13mm) vented air space is incorporated into exterior heat transfer coefficient					
10	5' (1.5m) x 4' (1.2m) Aluminum curtain wall (Passive House certified): triple glazed & thermally broken ² , IGU U _{IGU} = 0.14 BTU/hr.ft ² .°F (0.81 W/m ² K)					
11	Wood Liner	1/2" (13)	0.69 (0.10)	-	31 (500)	0.45 (1880)
12	Aluminum Flashing	14 Gauge	1110 (160)	-	171 (2739)	0.21 (900)
13	Concrete Floor Slab	8" (203)	12.5 (1.8)	-	140 (2250)	0.20 (850)
14	Exterior Film ¹	-	-	R-0.2 (0.03 RSI) to R-0.7 (0.12 RSI)	-	-

¹ Value selected from table 1, p. 26.1 of 2009 ASHRAE Handbook – Fundamentals depending on surface orientation

² The thermal conductivity of air spaces within framing was found using ISO 100077-2



Detail 5.3.13

Exterior and Interior Insulated 6" x 1 5/8" Steel Stud (16" o.c.) Wall Assembly with Thermally Isolated Vertical Brackets and Rail System (24" o.c.) Supporting Metal Cladding and R-19 Batt Insulation in Stud Cavity – Triple Glazed Aluminum Curtain Wall & Intermediate Floor Intersection with Window Thermal Break Positioned in the Exterior Insulation

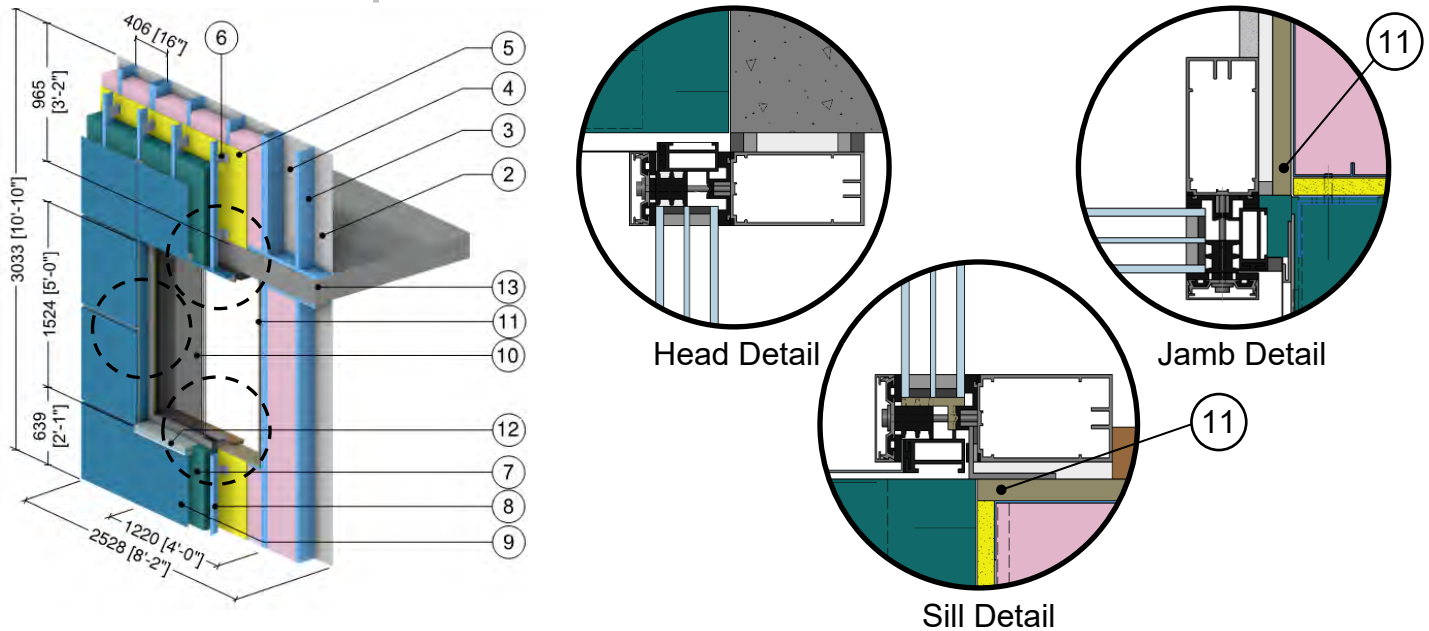

ID	Component	Thickness Inches (mm)	Conductivity Btu-in / ft ² -hr-°F (W/m K)	Nominal Resistance hr-ft ² -°F/Btu (m ² K/W)	Density lb/ft ³ (kg/m ³)	Specific Heat Btu/lb-°F (J/kg K)
1	Interior Film ¹	-	-	R-0.6 to R-1.1 (0.11 RSI to 0.20 RSI)	-	-
2	Gypsum Board	1/2" (13)	1.1 (0.16)	R-0.5 (0.08 RSI)	50 (800)	0.26 (1090)
3	6" x 1 5/8" Steel Studs (16" o.c.) with Top and Bottom Tracks	18 Gauge	430 (62)	-	489 (7830)	0.12 (500)
4	Fiberglas Batt Insulation	6" (152)	0.32 (0.046)	R-19 (3.35 RSI)	0.9 (1.1)	0.17 (710)
5	Exterior Sheathing	1/2" (13)	1.1 (0.16)	R-0.5 (0.08 RSI)	50 (800)	0.26 (1090)
6	Thermally Isolated Aluminum Bracket	0.09" (2.2)	1110 (160)	-	171 (2739)	0.21 (900)
7	Exterior Insulation	Varies	-	R-10 to R-25 (1.76 RSI to 4.40 RSI)	1.8 (28)	0.29 (1220)
8	Vertical Aluminum L-girt	0.09" (2.2)	1110 (160)	-	171 (2739)	0.21 (900)
9	Generic Cladding with 1/2" (13mm) vented air space is incorporated into exterior heat transfer coefficient					
10	5' (1.5m) x 4' (1.2m) Aluminum curtain wall (Passive House certified): triple glazed & thermally broken ² , IGU U _{IGU} = 0.14 BTU/hr.ft ² .°F (0.81 W/m ² K)					
11	Wood Liner	1/2" (13)	0.69 (0.10)	-	31 (500)	0.45 (1880)
12	Aluminum Flashing	14 Gauge	1110 (160)	-	171 (2739)	0.21 (900)
13	Concrete Floor Slab	8" (203)	12.5 (1.8)	-	140 (2250)	0.20 (850)
14	Exterior Film ¹	-	-	R-0.2 (0.03 RSI) to R-0.7 (0.12 RSI)	-	-

¹ Value selected from table 1, p. 26.1 of 2009 ASHRAE Handbook – Fundamentals depending on surface orientation

² The thermal conductivity of air spaces within framing was found using ISO 100077-2

Detail 5.3.14

Owens Corning Exterior Insulated 6" x 1 5/8" Steel Stud (16" o.c.) Wall Assembly with Thermally Isolated Vertical Brackets and Rail System (24" o.c.) Supporting Metal Cladding – Double Glazed Aluminum Window and Intermediate Floor Intersection

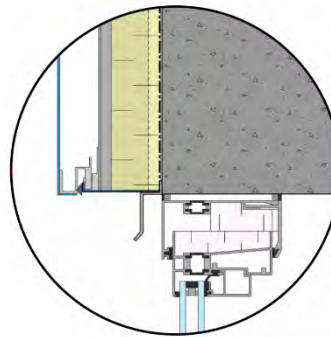
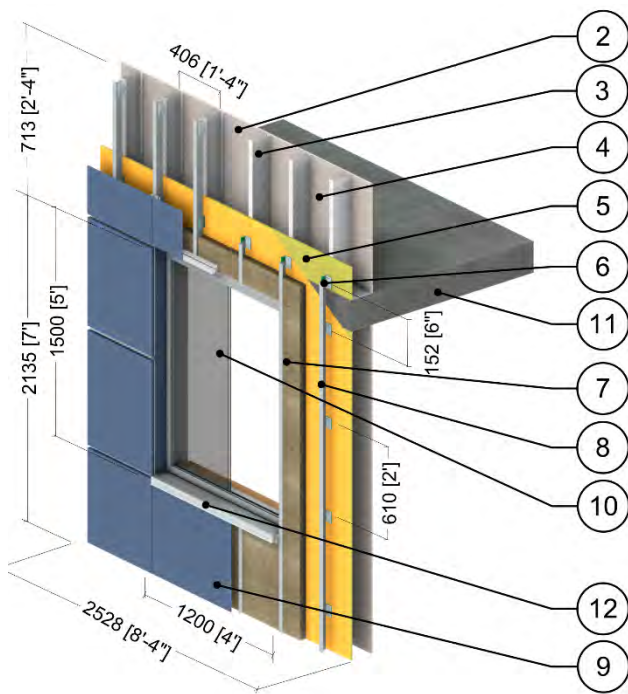

Head Detail

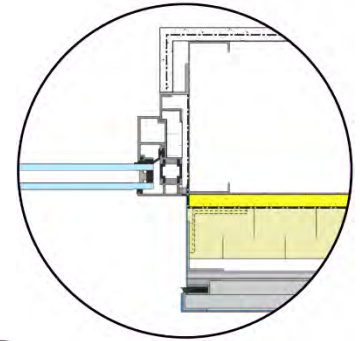

Jamb Detail

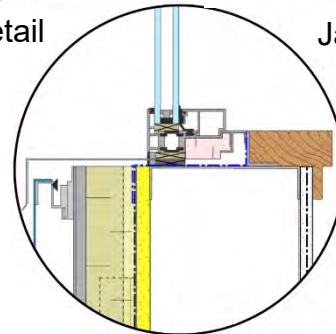

Sill Detail

ID	Component	Thickness Inches (mm)	Conductivity Btu-in / ft ² -hr-°F (W/m K)	Nominal Resistance hr-ft ² -°F/Btu (m ² K/W)	Density lb/ft ³ (kg/m ³)	Specific Heat Btu/lb-°F (J/kg K)
1	Interior Film ¹	-	-	R-0.6 to R-1.1 (0.11 to 0.20 RSI)	-	-
2	Gypsum Board	1/2" (13)	1.1 (0.16)	R-0.5 (0.08 RSI)	50 (800)	0.26 (1090)
3	6" x 1 5/8" Steel Studs with Tracks	18 Gauge	430 (62)	-	489 (7830)	0.12 (500)
4	Air in Stud Cavity	6" (152)	-	R-0.9 (0.16 RSI)	0.075 (1.2)	0.24 (1000)
5	Exterior Sheathing	5/8" (16)	1.1 (0.16)	R-0.6 (0.10 RSI)	50 (800)	0.26 (1090)
6	Thermally Isolated Aluminum Bracket	varies	-	-	-	-
7	Thermafiber RainBarrier 45 Mineral Wool Semi Rigid Insulation	varies	0.24 (0.034)	R-8.4 to R-21.0 (1.48 to 3.70 RSI)	4.5 (72)	0.20 (850)
8	Vertical Aluminum L-girt	0.09" (2.2)	1110 (160)	-	171 (2739)	0.22 (900)
9	Metal Cladding with 1/2" vented airspace incorporated into exterior heat transfer coefficient					
10	5' (1.5m) x 4' (1.2m) Aluminum window: thermally broken, double glazed IGU ² U _{IGU} = 0.32 BTU/hr.ft ² .°F (1.82 W/m ² K)					
11	Concrete Slab	8" (203)	12.5 (1.8)	-	140 (2250)	0.20 (850)
12	Aluminum Flashing	18 gauge	1110 (160)	-	171 (2739)	0.22 (900)
13	Exterior Film ¹	-	-	R-0.2 to R-0.7 (0.03 to 0.12 RSI)	-	-

¹ Value selected from table 1, p. 26.1 of 2009 ASHRAE Handbook – Fundamentals depending on surface orientation

² The thermal conductivity of air spaces was found using ISO 100077-2

Detail 5.3.15

Exterior and Interior Insulated 6" x 1 5/8" Steel Stud (16" o.c.) Wall Assembly with Thermally Isolated Vertical Brackets and Rail System (24" o.c.) Supporting Metal Cladding and Owens Corning R-20 Batt in Stud Cavity – Double Glazed Aluminum Window and Intermediate Floor Intersection

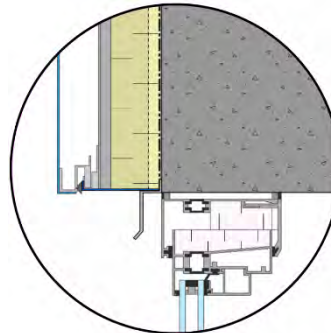
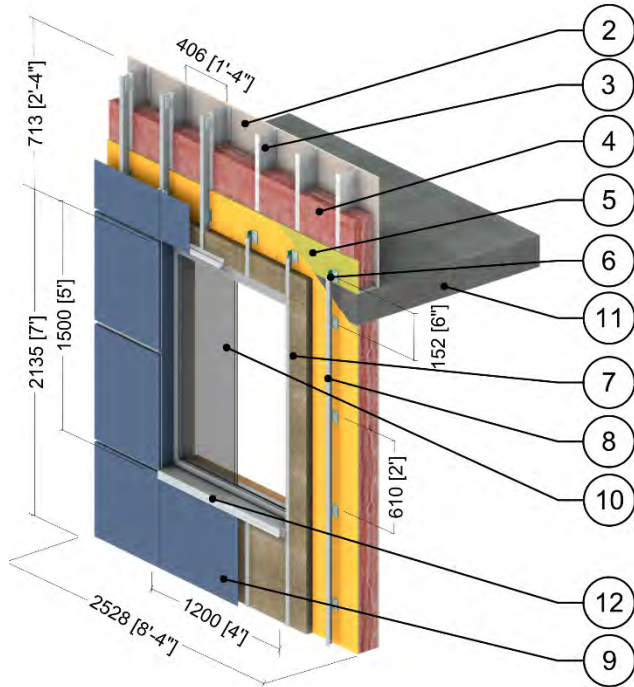

Head Detail

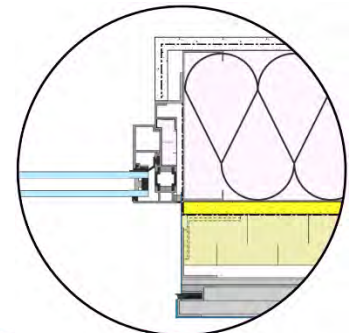

Jamb Detail

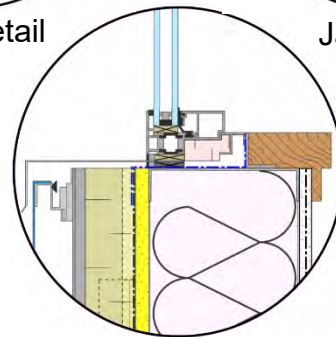

Sill Detail

ID	Component	Thickness Inches (mm)	Conductivity Btu-in / ft ² ·hr·°F (W/m K)	Nominal Resistance hr·ft ² ·°F/Btu (m ² K/W)	Density lb/ft ³ (kg/m ³)	Specific Heat Btu/lb·°F (J/kg K)
1	Interior Film ¹	-	-	R-0.6 to R-1.1 (0.11 to 0.20 RSI)	-	-
2	Gypsum Board	1/2" (13)	1.1 (0.16)	R-0.5 (0.08 RSI)	50 (800)	0.26 (1090)
3	6" x 1 5/8" Steel Studs with Tracks	18 Gauge	430 (62)	-	489 (7830)	0.12 (500)
4	Ecotouch Pink Fiberglass Batt	6" (152)	0.30 (0.043)	R-20 (3.52 RSI)	0.55 (8.8)	0.17 (710)
5	Exterior Sheathing	5/8" (16)	1.1 (0.16)	R-0.6 (0.10 RSI)	50 (800)	0.26 (1090)
6	Thermally Isolated Aluminum Bracket	varies	-	-	-	-
7	Thermafiber RainBarrier 45 Mineral Wool Semi Rigid Insulation	varies	0.24 (0.034)	R-8.4 to R-21.0 (1.48 to 3.70 RSI)	4.5 (72)	0.20 (850)
8	Vertical Aluminum L-girt	0.09" (2.2)	1110 (160)	-	171 (2739)	0.22 (900)
9	Metal Cladding with 1/2" vented airspace incorporated into exterior heat transfer coefficient					
10	5' (1.5m) x 4' (1.2m) Aluminum window: thermally broken, double glazed IGU ² U _{IGU} = 0.32 BTU/hr.ft ² ·°F (1.82 W/m ² K)					
11	Concrete Slab	8" (203)	12.5 (1.8)	-	140 (2250)	0.20 (850)
12	Aluminum Flashing	18 gauge	1110 (160)	-	171 (2739)	0.22 (900)
13	Exterior Film ¹	-	-	R-0.2 to R-0.7 (0.03 to 0.12 RSI)	-	-

¹ Value selected from table 1, p. 26.1 of 2009 ASHRAE Handbook – Fundamentals depending on surface orientation

² The thermal conductivity of air spaces was found using ISO 100077-2

Detail 5.3.16

Exterior and Interior Insulated 6" x 1 5/8" Steel Stud (16" o.c.) Wall Assembly with Thermally Isolated Vertical Brackets and Rail System (24" o.c.) Supporting Metal Cladding and Owens Corning R-22.5 Batt in Stud Cavity – Double Glazed Aluminum Window and Intermediate Floor Intersection

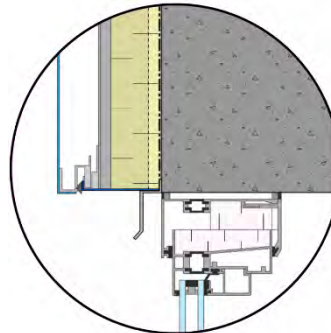
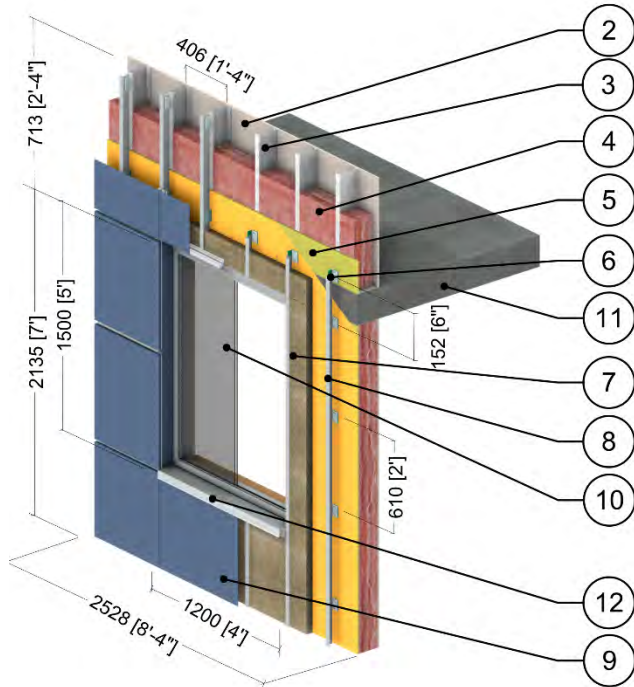

Head Detail

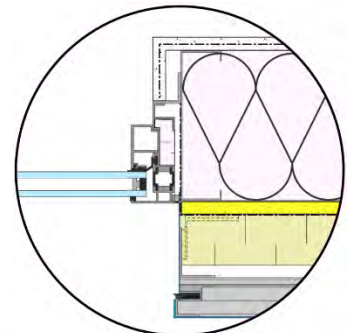

Jamb Detail

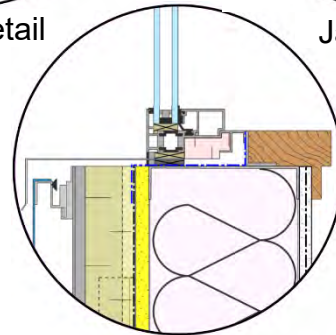

Sill Detail

ID	Component	Thickness Inches (mm)	Conductivity Btu-in / ft ² ·hr·°F (W/m K)	Nominal Resistance hr·ft ² ·°F/Btu (m ² K/W)	Density lb/ft ³ (kg/m ³)	Specific Heat Btu/lb·°F (J/kg K)
1	Interior Film ¹	-	-	R-0.6 to R-1.1 (0.11 to 0.20 RSI)	-	-
2	Gypsum Board	1/2" (13)	1.1 (0.16)	R-0.5 (0.08 RSI)	50 (800)	0.26 (1090)
3	6" x 1 5/8" Steel Studs with Tracks	18 Gauge	430 (62)	-	489 (7830)	0.12 (500)
4	Ecotouch Pink Fiberglass Batt	6" (152)	0.26 (0.038)	R-22.5 (3.96 RSI)	0.99 (15.9)	0.17 (710)
5	Exterior Sheathing	5/8" (16)	1.1 (0.16)	R-0.6 (0.10 RSI)	50 (800)	0.26 (1090)
6	Thermally Isolated Aluminum Bracket	varies	-	-	-	-
7	Thermafiber RainBarrier 45 Mineral Wool Semi Rigid Insulation	varies	0.24 (0.034)	R-8.4 to R-21.0 (1.48 to 3.70 RSI)	4.5 (72)	0.20 (850)
8	Vertical Aluminum L-girt	0.09" (2.2)	1110 (160)	-	171 (2739)	0.22 (900)
9	Metal Cladding with 1/2" vented airspace incorporated into exterior heat transfer coefficient					
10	5' (1.5m) x 4' (1.2m) Aluminum window: thermally broken, double glazed IGU ² U _{IGU} = 0.32 BTU/hr.ft ² ·°F (1.82 W/m ² K)					
11	Concrete Slab	8" (203)	12.5 (1.8)	-	140 (2250)	0.20 (850)
12	Aluminum Flashing	18 gauge	1110 (160)	-	171 (2739)	0.22 (900)
13	Exterior Film ¹	-	-	R-0.2 to R-0.7 (0.03 to 0.12 RSI)	-	-

¹ Value selected from table 1, p. 26.1 of 2009 ASHRAE Handbook – Fundamentals depending on surface orientation

² The thermal conductivity of air spaces was found using ISO 100077-2

Detail 5.3.17

Owens Corning Exterior Insulated 6" x 1 5/8" Steel Stud (16" o.c.) Wall Assembly with Thermally Isolated Vertical Brackets and Rail System (24" o.c.) Supporting Metal Cladding – Triple Glazed Aluminum Window and Intermediate Floor Intersection

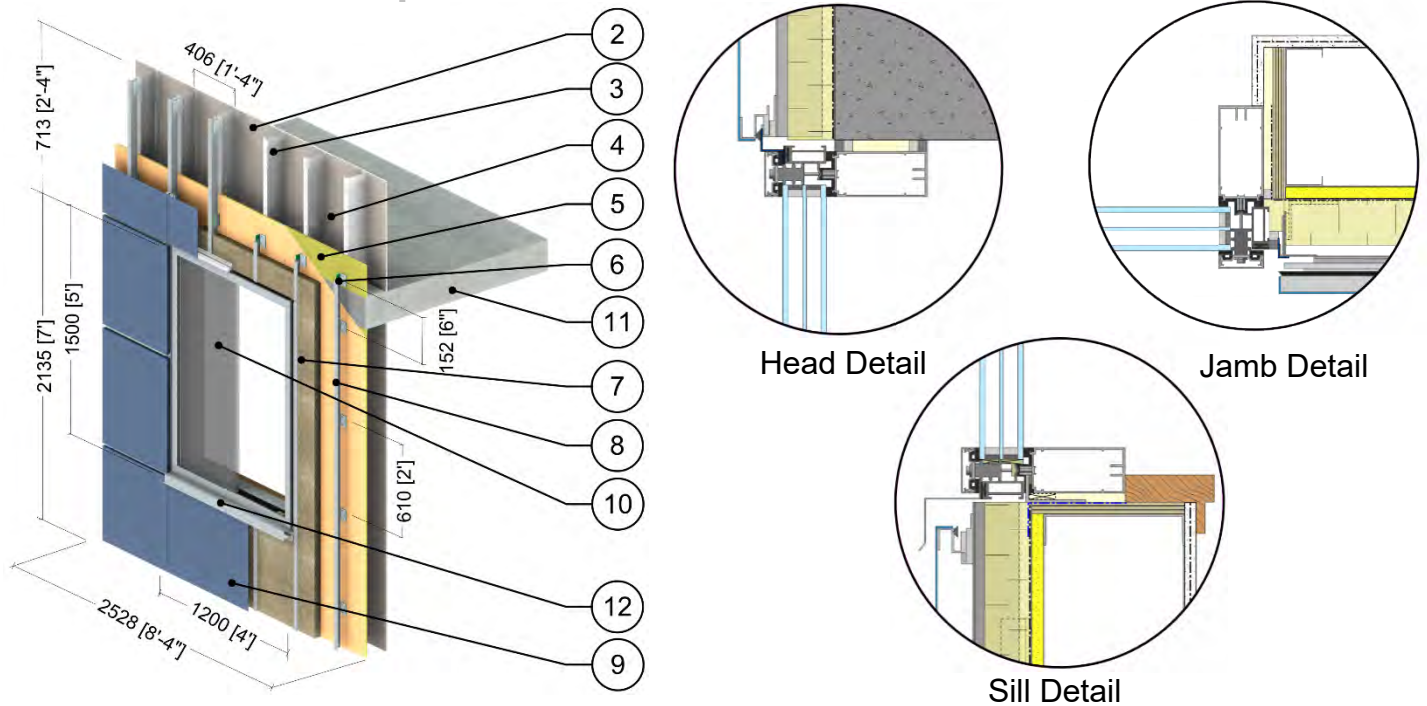

ID	Component	Thickness Inches (mm)	Conductivity Btu-in / ft ² -hr-°F (W/m K)	Nominal Resistance hr-ft ² -°F/Btu (m ² K/W)	Density lb/ft ³ (kg/m ³)	Specific Heat Btu/lb-°F (J/kg K)
1	Interior Film ¹	-	-	R-0.6 to R-1.1 (0.11 to 0.20 RSI)	-	-
2	Gypsum Board	1/2" (13)	1.1 (0.16)	R-0.5 (0.08 RSI)	50 (800)	0.26 (1090)
3	6" x 1 5/8" Steel Studs with Tracks	18 Gauge	430 (62)	-	489 (7830)	0.12 (500)
4	Air in Stud Cavity	6" (152)	-	R-0.9 (0.16 RSI)	0.075 (1.2)	0.24 (1000)
5	Exterior Sheathing	5/8" (16)	1.1 (0.16)	R-0.6 (0.10 RSI)	50 (800)	0.26 (1090)
6	Thermally Isolated Aluminum Bracket	varies	-	-	-	-
7	Thermafiber RainBarrier 45 Mineral Wool Semi Rigid Insulation	varies	0.24 (0.034)	R-8.4 to R-21.0 (1.48 to 3.70 RSI)	4.5 (72)	0.20 (850)
8	Vertical Aluminum L-girt	0.09" (2.2)	1110 (160)	-	171 (2739)	0.22 (900)
9	Metal Cladding with 1/2" vented airspace incorporated into exterior heat transfer coefficient					
10	5' (1.5m) x 4' (1.2m) Aluminum window: thermally broken, triple glazed IGU ² U _{IGU} = 0.220 BTU/hr.ft ² .°F (1.25 W/m ² K)					
11	Concrete Slab	8" (203)	12.5 (1.8)	-	140 (2250)	0.20 (850)
12	Aluminum Flashing	18 gauge	1110 (160)	-	171 (2739)	0.22 (900)
13	Exterior Film ¹	-	-	R-0.2 to R-0.7 (0.03 to 0.12 RSI)	-	-

¹ Value selected from table 1, p. 26.1 of 2009 ASHRAE Handbook – Fundamentals depending on surface orientation

² The thermal conductivity of air spaces was found using ISO 100077-2

Detail 5.3.18

Exterior and Interior Insulated 6" x 1 5/8" Steel Stud (16" o.c.) Wall Assembly with Thermally Isolated Vertical Brackets and Rail System (24" o.c.) Supporting Metal Cladding and Owens Corning R-20 Batt in Stud Cavity – Triple Glazed Aluminum Window and Intermediate Floor Intersection

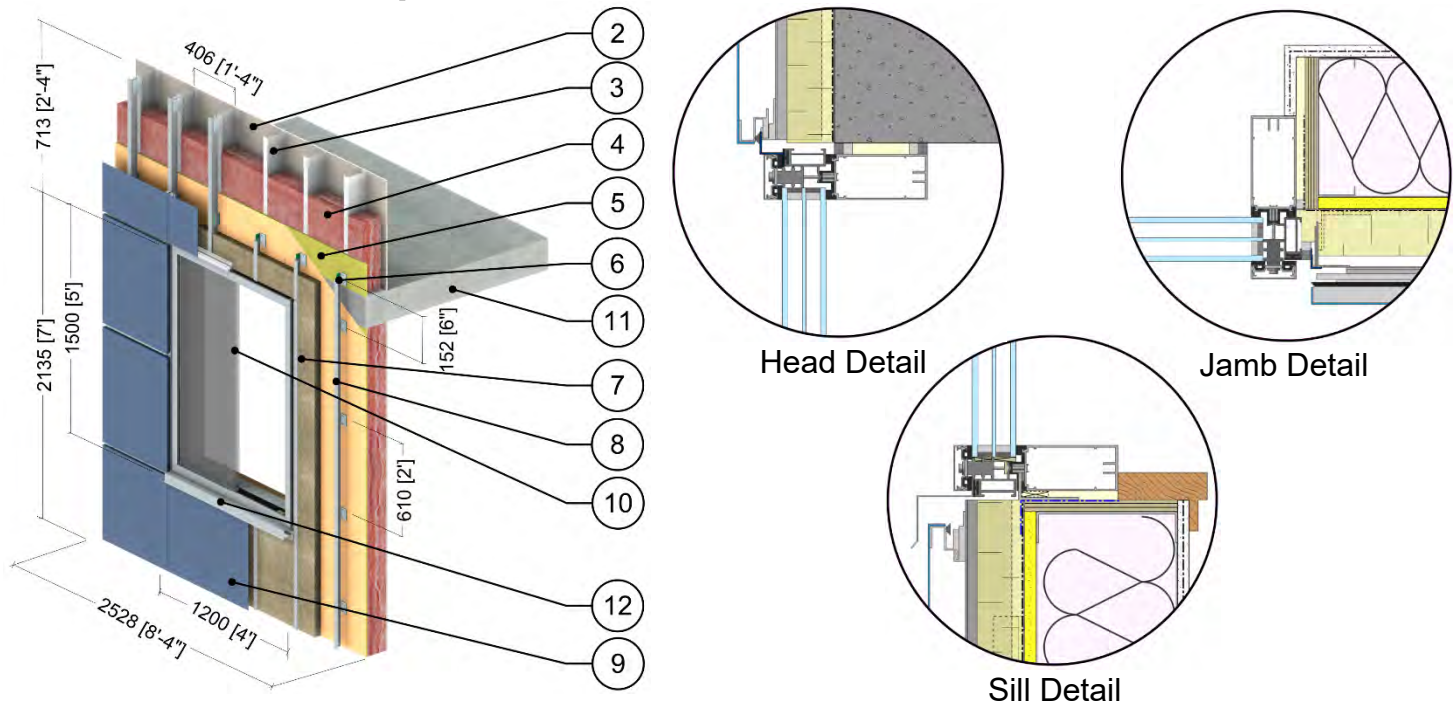

ID	Component	Thickness Inches (mm)	Conductivity Btu-in / ft ² ·hr·°F (W/m K)	Nominal Resistance hr·ft ² ·°F/Btu (m ² K/W)	Density lb/ft ³ (kg/m ³)	Specific Heat Btu/lb·°F (J/kg K)
1	Interior Film ¹	-	-	R-0.6 to R-1.1 (0.11 to 0.20 RSI)	-	-
2	Gypsum Board	1/2" (13)	1.1 (0.16)	R-0.5 (0.08 RSI)	50 (800)	0.26 (1090)
3	6" x 1 5/8" Steel Studs with Tracks	18 Gauge	430 (62)	-	489 (7830)	0.12 (500)
4	Ecotouch Pink Fiberglass Batt	6" (152)	0.30 (0.043)	R-20 (3.52 RSI)	0.55 (8.8)	0.17 (710)
5	Exterior Sheathing	5/8" (16)	1.1 (0.16)	R-0.6 (0.10 RSI)	50 (800)	0.26 (1090)
6	Thermally Isolated Aluminum Bracket	varies	-	-	-	-
7	Thermafiber RainBarrier 45 Mineral Wool Semi Rigid Insulation	varies	0.24 (0.034)	R-8.4 to R-21.0 (1.48 to 3.70 RSI)	4.5 (72)	0.20 (850)
8	Vertical Aluminum L-girt	0.09" (2.2)	1110 (160)	-	171 (2739)	0.22 (900)
9	Metal Cladding with 1/2" vented airspace incorporated into exterior heat transfer coefficient					
10	5' (1.5m) x 4' (1.2m) Aluminum window: thermally broken, double glazed IGU ² U _{IGU} = 0.220 BTU/hr.ft ² ·°F (1.25 W/m ² K)					
11	Concrete Slab	8" (203)	12.5 (1.8)	-	140 (2250)	0.20 (850)
12	Aluminum Flashing	18 gauge	1110 (160)	-	171 (2739)	0.22 (900)
13	Exterior Film ¹	-	-	R-0.2 to R-0.7 (0.03 to 0.12 RSI)	-	-

¹ Value selected from table 1, p. 26.1 of 2009 ASHRAE Handbook – Fundamentals depending on surface orientation

² The thermal conductivity of air spaces was found using ISO 100077-2

Detail 5.3.19

Exterior and Interior Insulated 6" x 1 5/8" Steel Stud (16" o.c.) Wall Assembly with Thermally Isolated Vertical Brackets and Rail System (24" o.c.) Supporting Metal Cladding and Owens Corning R-22.5 Batt in Stud Cavity – Triple Glazed Aluminum Window and Intermediate Floor Intersection

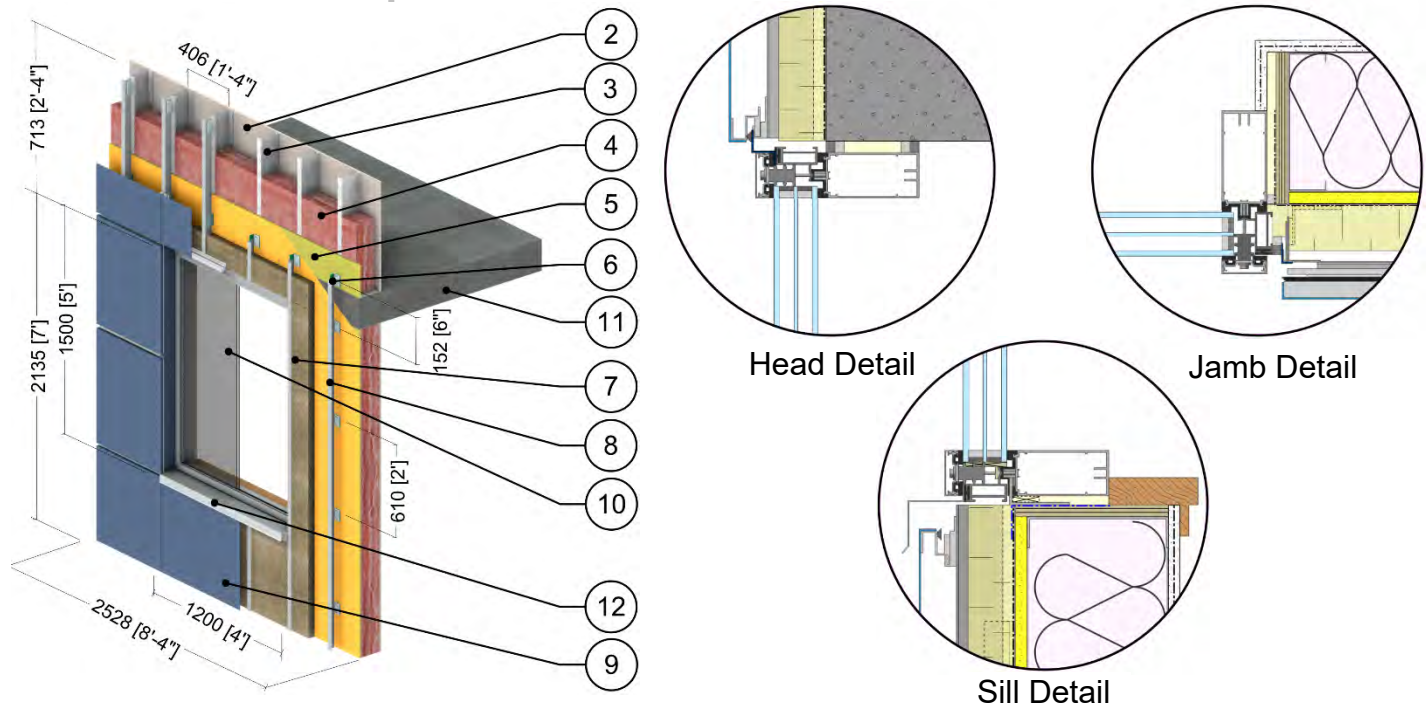

ID	Component	Thickness Inches (mm)	Conductivity Btu-in / ft ² ·hr·°F (W/m K)	Nominal Resistance hr·ft ² ·°F/Btu (m ² K/W)	Density lb/ft ³ (kg/m ³)	Specific Heat Btu/lb·°F (J/kg K)
1	Interior Film ¹	-	-	R-0.6 to R-1.1 (0.11 to 0.20 RSI)	-	-
2	Gypsum Board	1/2" (13)	1.1 (0.16)	R-0.5 (0.08 RSI)	50 (800)	0.26 (1090)
3	6" x 1 5/8" Steel Studs with Tracks	18 Gauge	430 (62)	-	489 (7830)	0.12 (500)
4	Ecotouch Pink Fiberglass Batt	6" (152)	0.26 (0.038)	R-22.5 (3.96 RSI)	0.99 (15.9)	0.17 (710)
5	Exterior Sheathing	5/8" (16)	1.1 (0.16)	R-0.6 (0.10 RSI)	50 (800)	0.26 (1090)
6	Thermally Isolated Aluminum Bracket	varies	-	-	-	-
7	Thermafiber RainBarrier 45 Mineral Wool Semi Rigid Insulation	varies	0.24 (0.034)	R-8.4 to R-21.0 (1.48 to 3.70 RSI)	4.5 (72)	0.20 (850)
8	Vertical Aluminum L-girt	0.09" (2.2)	1110 (160)	-	171 (2739)	0.22 (900)
9	Metal Cladding with 1/2" vented airspace incorporated into exterior heat transfer coefficient					
10	5' (1.5m) x 4' (1.2m) Aluminum window: thermally broken, double glazed IGU ² U _{IGU} = 0.220 BTU/hr.ft ² .°F (1.25 W/m ² K)					
11	Concrete Slab	8" (203)	12.5 (1.8)	-	140 (2250)	0.20 (850)
12	Aluminum Flashing	18 gauge	1110 (160)	-	171 (2739)	0.22 (900)
13	Exterior Film ¹	-	-	R-0.2 to R-0.7 (0.03 to 0.12 RSI)	-	-

¹ Value selected from table 1, p. 26.1 of 2009 ASHRAE Handbook – Fundamentals depending on surface orientation

² The thermal conductivity of air spaces was found using ISO 100077-2

Detail 5.3.20

Exterior Insulated 6" x 1 5/8" Steel Stud (16" o.c.) Wall Assembly with FRP and Thermally Broken Vertical Brackets and Rail System Supporting Metal Cladding – Triple Glazed Vinyl Window and Intermediate Floor Intersection

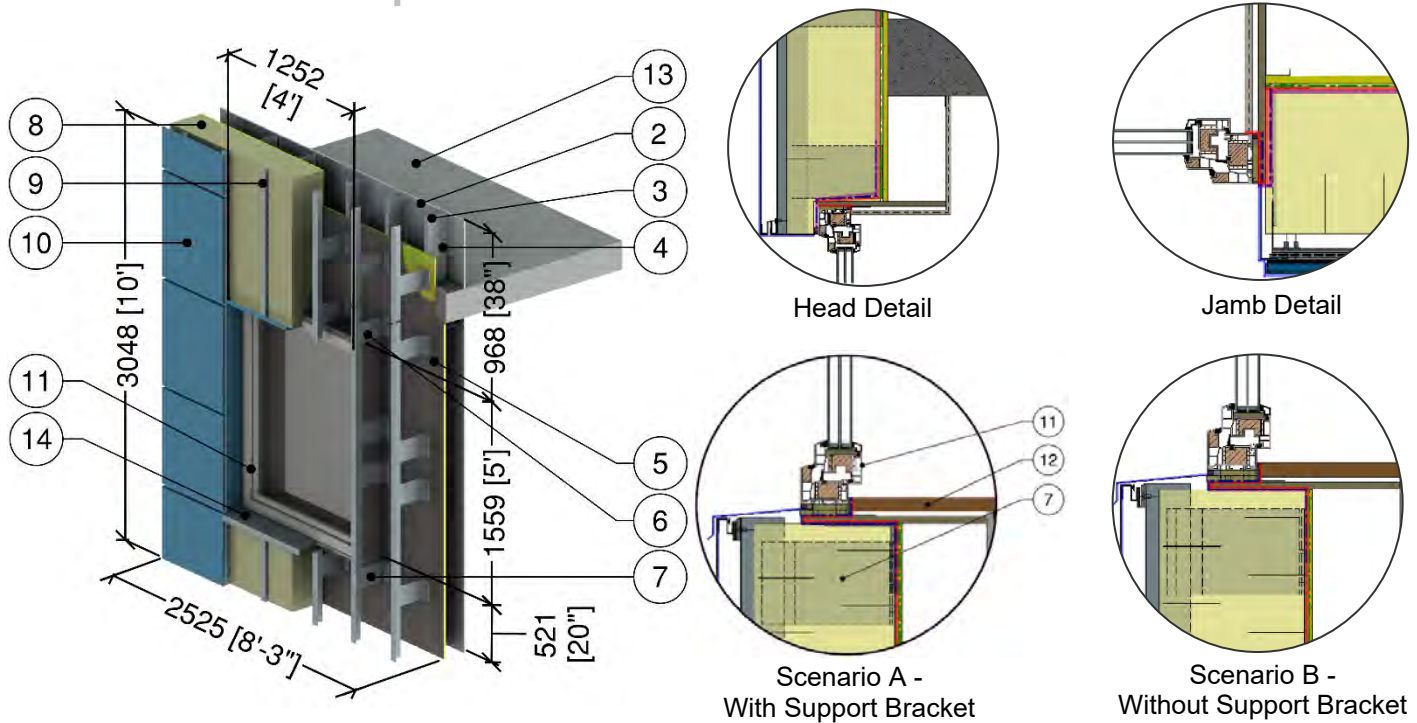

ID	Component	Thickness Inches (mm)	Conductivity Btu-in / ft ² ·hr·°F (W/m K)	Nominal Resistance hr·ft ² ·°F/Btu (m ² K/W)	Density lb/ft ³ (kg/m ³)	Specific Heat Btu/lb·°F (J/kg K)
1	Interior Film ¹	-	-	R-0.6 to R-1.1 (0.11 to 0.20 RSI)	-	-
2	Gypsum Board	1/2" (13)	1.1 (0.16)	R-0.5 (0.08 RSI)	50 (800)	0.26 (1090)
3	6" x 1 5/8" Steel Studs with Tracks	18 Gauge	430 (62)	-	489 (7830)	0.12 (500)
4	Air in Stud Cavity	6" (152)	-	R-0.9 (0.16 RSI)	0.075 (1.2)	0.24 (1000)
5	Exterior Sheathing	1/2" (13)	1.1 (0.16)	R-0.5 (0.08 RSI)	50 (800)	0.26 (1090)
6	FRP Bracket	-	4.85 (0.7)	-	110 (1760)	-
7	Aluminum Bracket	-	1110 (160)	-	171 (2739)	0.22 (900)
8	Exterior Mineral Wool Insulation	10" (254)	0.24 (0.034)	R-42 (7.40 RSI)	4.5 (72)	0.20 (850)
9	Vertical Aluminum L-Rail	0.09" (2.2)	1110 (160)	-	171 (2739)	0.22 (900)
10	Metal Cladding with 1/2" vented airspace incorporated into exterior heat transfer coefficient					
11	5' (1.5m) x 4' (1.2m) Vinyl window: thermally broke, triple glazed IGU ² U _{IGU} = 0.13 BTU/hr·ft ² ·°F (0.72 W/m ² K)					
12	Wood Liner	1/2" (13)	0.69 (0.10)	-	31 (500)	0.45 (1880)
13	Concrete Slab	8" (203)	12.5 (1.8)	-	140 (2250)	0.20 (850)
14	Aluminum Flashing	18 Gauge	1110 (160)	-	171 (2739)	0.21 (900)
15	Exterior Film ¹	-	-	R-0.2 to R-0.7 (0.03 to 0.12 RSI)	-	-

¹ Value selected from table 1, p. 26.1 of 2009 ASHRAE Handbook – Fundamentals depending on surface orientation

² The thermal conductivity of air spaces was found using ISO 100077-2



Detail 5.3.21

Exterior Insulated 6" x 1 5/8" Steel Stud (16" o.c.) Wall Assembly with FRP and Thermally Broken Vertical Brackets and Rail System Supporting Metal Cladding with Aerogel Insulation Blanket – Triple Glazed Vinyl Window and Intermediate Floor Intersection

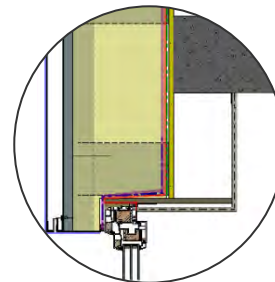
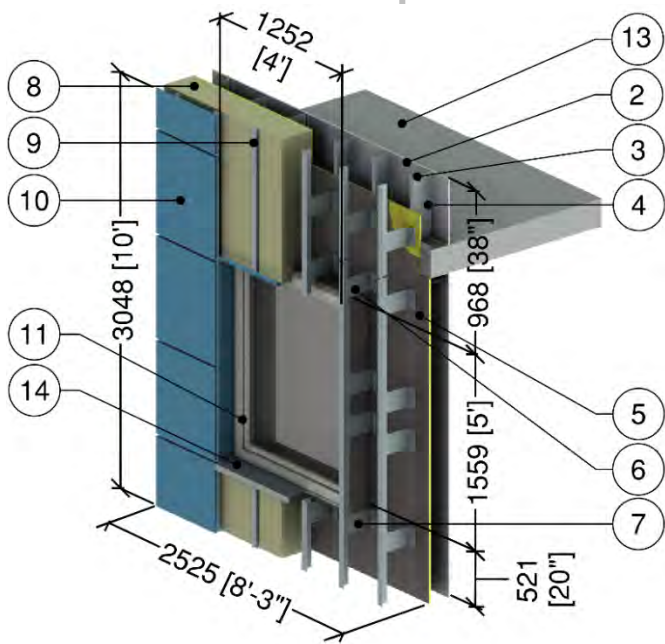

Head Detail

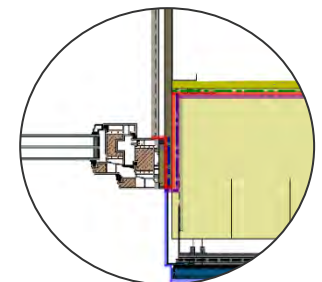

Jamb Detail

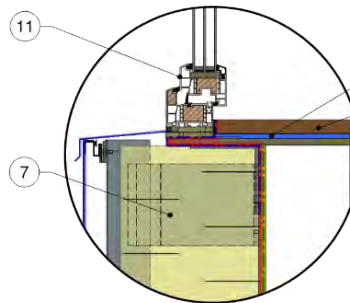

Scenario A -
With Support Bracket

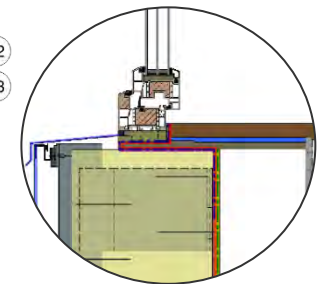

Scenario B -
Without Support Bracket

ID	Component	Thickness Inches (mm)	Conductivity Btu-in / ft ² -hr-°F (W/m K)	Nominal Resistance hr-ft ² -°F/Btu (m ² K/W)	Density lb/ft ³ (kg/m ³)	Specific Heat Btu/lb-°F (J/kg K)
1	Interior Film ¹	-	-	R-0.6 to R-1.1 (0.11 to 0.20 RSI)	-	-
2	Gypsum Board	1/2" (13)	1.1 (0.16)	R-0.5 (0.08 RSI)	50 (800)	0.26 (1090)
3	6" x 1 5/8" Steel Studs with Tracks	18 Gauge	430 (62)	-	489 (7830)	0.12 (500)
4	Air in Stud Cavity	6" (152)	-	R-0.9 (0.16 RSI)	0.075 (1.2)	0.24 (1000)
5	Exterior Sheathing	1/2" (13)	1.1 (0.16)	R-0.5 (0.08 RSI)	50 (800)	0.26 (1090)
6	FRP Bracket	-	4.85 (0.7)	-	110 (1760)	-
7	Aluminum Bracket	-	1110 (160)	-	171 (2739)	0.22 (900)
8	Exterior Mineral Wool Insulation	10" (254)	0.24 (0.034)	R-42 (7.40 RSI)	4.5 (72)	0.20 (850)
9	Vertical Aluminum L-Rail	0.09" (2.2)	1110 (160)	-	171 (2739)	0.22 (900)
10	Metal Cladding with 1/2" vented airspace incorporated into exterior heat transfer coefficient					
11	5' (1.5m) x 4' (1.2m) Vinyl window: thermally broke, triple glazed IGU ² U _{IGU} = 0.13 BTU/hr-ft ² -°F (0.72 W/m ² K)					
12	Aerogel Insulation Blanket	3/8" (10)	0.10 (0.014)	R-4.1 (0.71 RSI)	12.5 (200)	-
13	Wood Liner	1/2" (13)	0.69 (0.10)	-	31 (500)	0.45 (1880)
14	Concrete Slab	8" (203)	12.5 (1.8)	-	140 (2250)	0.20 (850)
15	Aluminum Flashing	18 Gauge	1110 (160)	-	171 (2739)	0.21 (900)
16	Exterior Film ¹	-	-	R-0.2 to R-0.7 (0.03 to 0.12 RSI)	-	-

¹ Value selected from table 1, p. 26.1 of 2009 ASHRAE Handbook – Fundamentals depending on surface orientation

² The thermal conductivity of air spaces was found using ISO 100077-2



Detail 5.3.22

Exterior and Interior Insulated 6" x 1 5/8" Steel Stud (16" o.c.) Wall Assembly with FRP and Thermally Broken Vertical Brackets and Rail System Supporting Metal Cladding and R-19 Batt in Stud Cavity – Triple Glazed Vinyl Window and Intermediate Floor Intersection

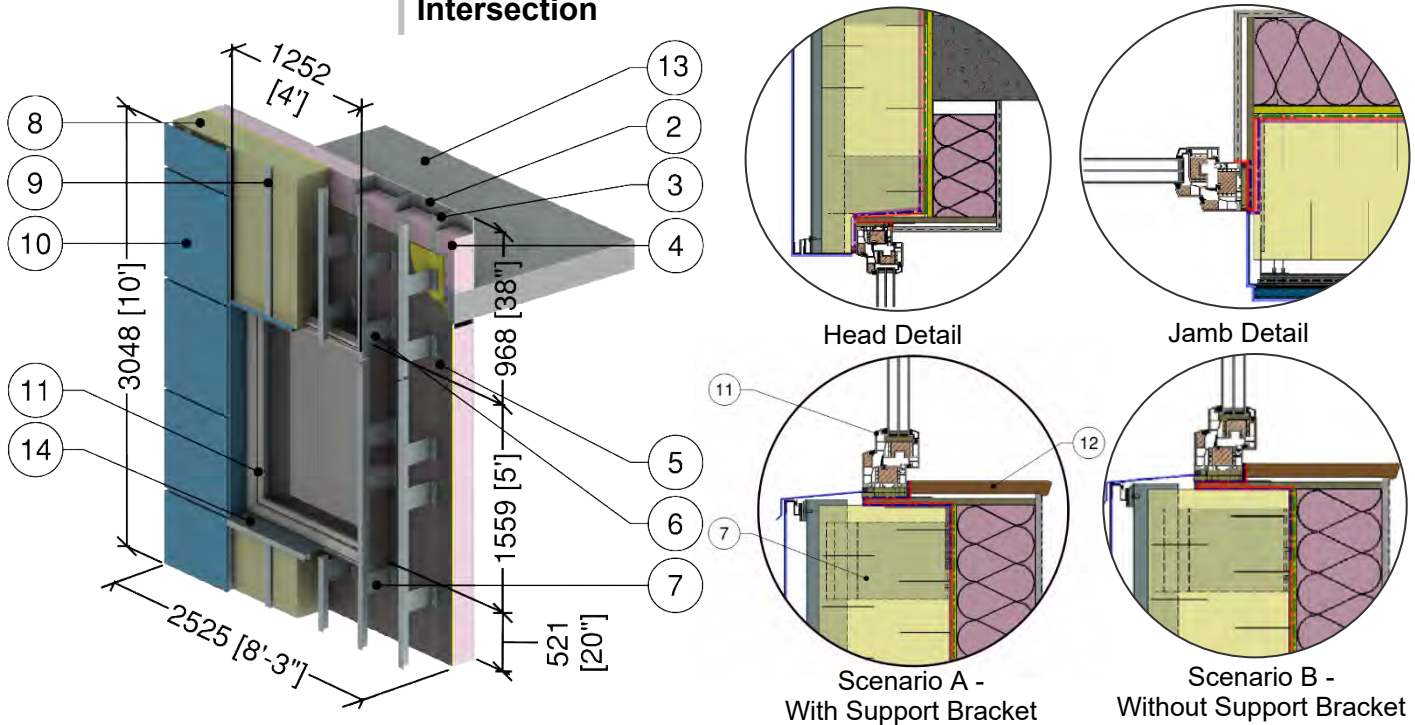

ID	Component	Thickness Inches (mm)	Conductivity Btu-in / ft ² -hr-°F (W/m K)	Nominal Resistance hr-ft ² -°F/Btu (m ² K/W)	Density lb/ft ³ (kg/m ³)	Specific Heat Btu/lb-°F (J/kg K)
1	Interior Film ¹	-	-	R-0.6 to R-1.1 (0.11 to 0.20 RSI)	-	-
2	Gypsum Board	1/2" (13)	1.1 (0.16)	R-0.5 (0.08 RSI)	50 (800)	0.26 (1090)
3	6" x 1 5/8" Steel Studs with Tracks	18 Gauge	430 (62)	-	489 (7830)	0.12 (500)
4	Fiberglass Batt Insulation	6" (152)	0.32 (0.046)	R-19 (3.35 RSI)	0.9 (14)	0.17 (710)
5	Exterior Sheathing	1/2" (13)	1.1 (0.16)	R-0.5 (0.08 RSI)	50 (800)	0.26 (1090)
6	FRP Bracket	-	4.85 (0.7)	-	110 (1760)	-
7	Aluminum Bracket	-	1110 (160)	-	171 (2739)	0.22 (900)
8	Exterior Mineral Wool Insulation	10" (254)	0.24 (0.034)	R-42 (7.40 RSI)	4.5 (72)	0.20 (850)
9	Vertical Aluminum L-Rail	0.09" (2.2)	1110 (160)	-	171 (2739)	0.22 (900)
10	Metal Cladding with 1/2" vented airspace incorporated into exterior heat transfer coefficient					
11	5' (1.5m) x 4' (1.2m) Vinyl window: thermally broke, triple glazed IGU ² U _{IGU} = 0.13 BTU/hr-ft ² -°F (0.72 W/m ² K)					
12	Wood Liner	1/2" (13)	0.69 (0.10)	-	31 (500)	0.45 (1880)
13	Concrete Slab	8" (203)	12.5 (1.8)	-	140 (2250)	0.20 (850)
14	Aluminum Flashing	18 Gauge	1110 (160)	-	171 (2739)	0.21 (900)
15	Exterior Film ¹	-	-	R-0.2 to R-0.7 (0.03 to 0.12 RSI)	-	-

¹ Value selected from table 1, p. 26.1 of 2009 ASHRAE Handbook – Fundamentals depending on surface orientation

² The thermal conductivity of air spaces was found using ISO 100077-2



Detail 5.3.23

Exterior and Interior Insulated 6" x 1 5/8" Steel Stud (16" o.c.) Wall Assembly with FRP and Thermally Broken Vertical Brackets and Rail System Supporting Metal Cladding with Aerogel Insulation Blanket and R-19 Batt in Stud Cavity– Triple Glazed Vinyl Window and Intermediate Floor Intersection

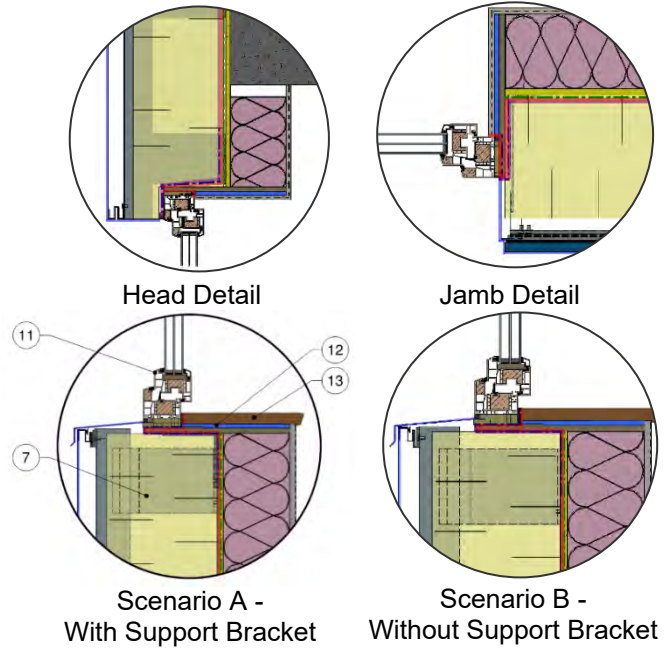
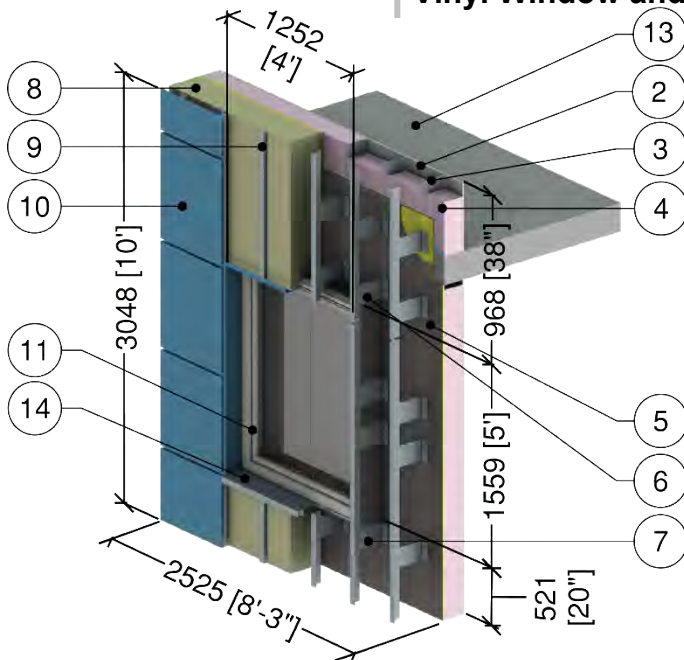

ID	Component	Thickness Inches (mm)	Conductivity Btu-in / ft ² ·hr·°F (W/m K)	Nominal Resistance hr·ft ² ·°F/Btu (m ² K/W)	Density lb/ft ³ (kg/m ³)	Specific Heat Btu/lb·°F (J/kg K)
1	Interior Film ¹	-	-	R-0.6 to R-1.1 (0.11 to 0.20 RSI)	-	-
2	Gypsum Board	1/2" (13)	1.1 (0.16)	R-0.5 (0.08 RSI)	50 (800)	0.26 (1090)
3	6" x 1 5/8" Steel Studs with Tracks	18 Gauge	430 (62)	-	489 (7830)	0.12 (500)
4	Fiberglass Batt Insulation	6" (152)	0.32 (0.046)	R-19 (3.35 RSI)	0.9 (14)	0.17 (710)
5	Exterior Sheathing	1/2" (13)	1.1 (0.16)	R-0.5 (0.08 RSI)	50 (800)	0.26 (1090)
6	FRP Bracket	-	4.85 (0.7)	-	110 (1760)	-
7	Aluminum Bracket	-	1110 (160)	-	171 (2739)	0.22 (900)
8	Exterior Mineral Wool Insulation	10" (254)	0.24 (0.034)	R-42 (7.40 RSI)	4.5 (72)	0.20 (850)
9	Vertical Aluminum L-Rail	0.09" (2.2)	1110 (160)	-	171 (2739)	0.22 (900)
10	Metal Cladding with 1/2" vented airspace incorporated into exterior heat transfer coefficient					
11	5' (1.5m) x 4' (1.2m) Vinyl window: thermally broke, triple glazed IGU ² U _{IGU} = 0.13 BTU/hr·ft ² ·°F (0.72 W/m ² K)					
12	Aerogel Insulation Blanket	3/8" (10)	0.10 (0.014)	R-4.1 (0.71 RSI)	12.5 (200)	-
13	Wood Liner	1/2" (13)	0.69 (0.10)	-	31 (500)	0.45 (1880)
14	Concrete Slab	8" (203)	12.5 (1.8)	-	140 (2250)	0.20 (850)
15	Aluminum Flashing	18 Gauge	1110 (160)	-	171 (2739)	0.21 (900)
16	Exterior Film ¹	-	-	R-0.2 to R-0.7 (0.03 to 0.12 RSI)	-	-

¹ Value selected from table 1, p. 26.1 of 2009 ASHRAE Handbook – Fundamentals depending on surface orientation

² The thermal conductivity of air spaces was found using ISO 100077-2



Detail 5.4.1

Exterior Insulated 3 5/8" x 1 5/8" Steel Stud (16" o.c.) Drained EIFS Wall Assembly – Conventional Curtain Wall Transition

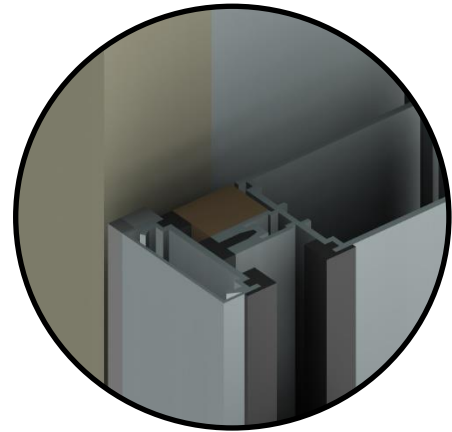
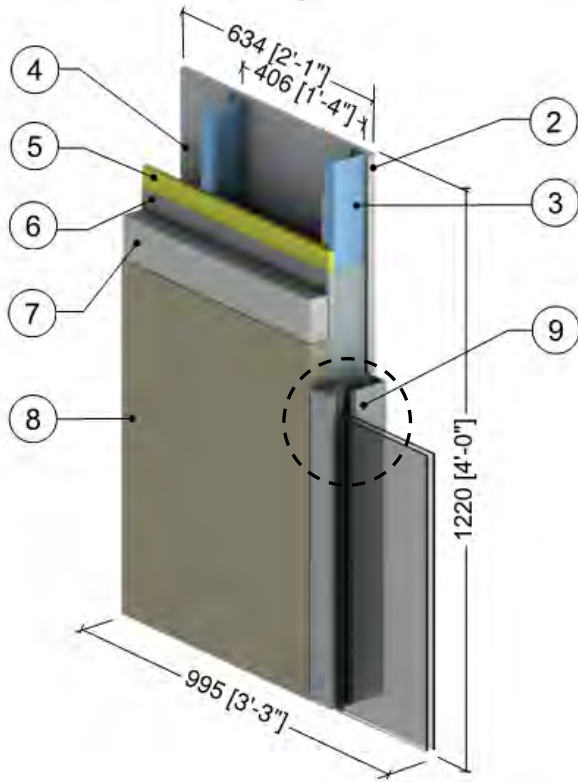

Curtain Wall Jamb Detail

ID	Component	Thickness Inches (mm)	Conductivity Btu·in / ft ² ·hr·°F (W/m K)	Nominal Resistance hr·ft ² ·°F/Btu (m ² K/W)	Density lb/ft ³ (kg/m ³)	Specific Heat Btu/lb·°F (J/kg K)
1	Interior Films ¹	-	-	R-0.7 to R-1.1 (0.12 RSI to 0.20 RSI)	-	-
2	Gypsum Board	1/2" (13)	1.1 (0.16)	R-0.5 (0.08 RSI)	50 (800)	0.26 (1090)
3	3 5/8" x 1 5/8" Steel Studs (16"o.c.)	18 Gauge	430 (62)	-	489 (7830)	0.12 (500)
4	Air in Stud Cavity	3 5/8" (92)	-	R-0.9 (0.16 RSI)	0.075 (1.2)	0.24 (1000)
5	Exterior Sheathing	1/2" (13)	1.1 (0.16)	R-0.5 (0.08 RSI)	50 (800)	0.26 (1090)
6	Weather Resistant Barrier with Adhesive	-	-	-	-	-
7	Insulation Board	Varies	0.27 (0.039)	R-7.5 to R-15 (1.32 RSI to 2.64 RSI)	1 (16)	0.35 (1470)
8	Lamina	1/8" (4)	6 (0.9)	R-0.04 (0.01 RSI)	120 (1922)	0.20 (850)
9	Conventional curtain wall system: double glazed with minimal thermal break ² , double glazed IGU U _{IGU} = 0.32 BTU/hr·ft ² °F (1.82 W/m ² K)					
10	Exterior Film ¹	-	-	R-0.2 (0.03 RSI)	-	-

¹ Value selected from table 1, p. 26.1 of 2009 ASHRAE Handbook – Fundamentals depending on surface orientation

² The thermal conductivity of air spaces within framing was found using ISO 100077-2

Detail 5.4.2

Exterior and Interior Insulated 3 5/8" x 1 5/8" Steel Stud (16" o.c.) Drained EIFS Wall Assembly with R-12 Batt Insulation in Stud Cavity – Conventional Curtain Wall Transition

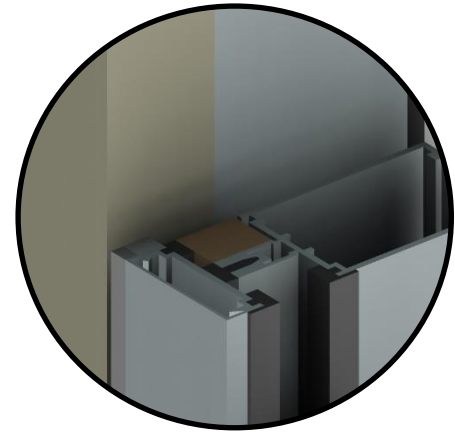
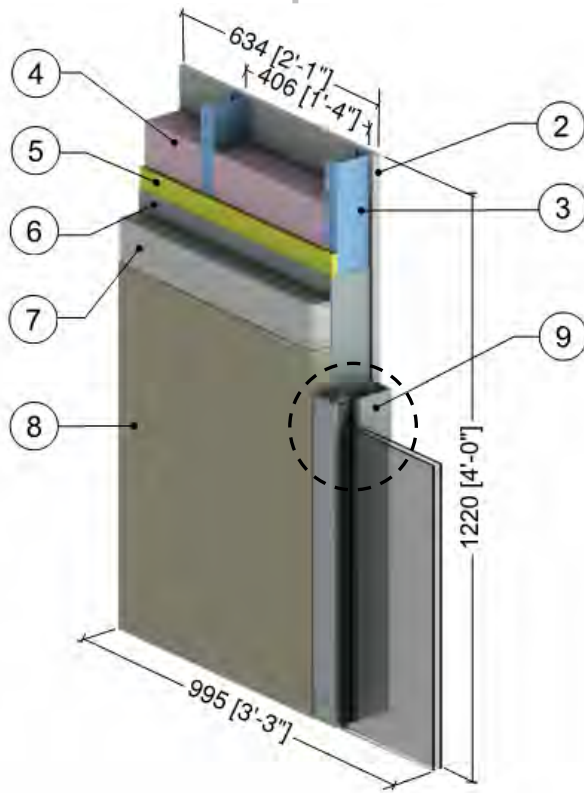

Curtain Wall
Jamb Detail

ID	Component	Thickness Inches (mm)	Conductivity Btu·in / ft ² ·hr·°F (W/m K)	Nominal Resistance hr·ft ² ·°F/Btu (m ² K/W)	Density lb/ft ³ (kg/m ³)	Specific Heat Btu/lb·°F (J/kg K)
1	Interior Films ¹	-	-	R-0.7 to R-1.1 (0.12 RSI to 0.20 RSI)	-	-
2	Gypsum Board	1/2" (13)	1.1 (0.16)	R-0.5 (0.08 RSI)	50 (800)	0.26 (1090)
3	3 5/8" x 1 5/8" Steel Studs (16" o.c.)	18 Gauge	430 (62)	-	489 (7830)	0.12 (500)
4	Fiberglass Batt Insulation	3 5/8" (92)	0.31 (0.044)	R-12 (2.1 RSI)	0.9 (1.1)	0.17 (710)
5	Exterior Sheathing	1/2" (13)	1.1 (0.16)	R-0.5 (0.08 RSI)	50 (800)	0.26 (1090)
6	Weather Resistant Barrier with Adhesive	-	-	-	-	-
7	Insulation Board	Varies	0.27 (0.039)	R-7.5 to R-15 (1.32 RSI to 2.64 RSI)	1 (16)	0.35 (1470)
8	Lamina	1/8" (4)	6 (0.9)	R-0.04 (0.01 RSI)	120 (1922)	0.20 (850)
9	Conventional curtain wall system: double glazed with minimal thermal break ² , double glazed IGU U _{IGU} = 0.32 BTU/hr·ft ² ·°F (1.82 W/m ² K)					
10	Exterior Film ¹	-	-	R-0.2 (0.03 RSI)	-	-

¹ Value selected from table 1, p. 26.1 of 2009 ASHRAE Handbook – Fundamentals depending on surface orientation

² The thermal conductivity of air spaces within framing was found using ISO 100077-2

Detail 5.4.3

Exterior and Interior Insulated 3 5/8" x 1 5/8" Steel Stud (16" o.c.) Wall Assembly with R-12 Batt Insulation in Stud Cavity – Curtain Wall Transition

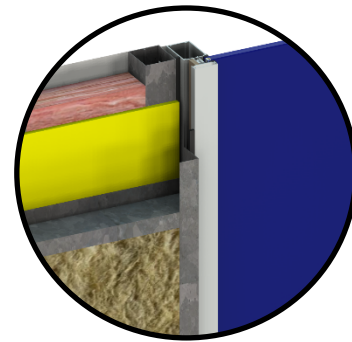
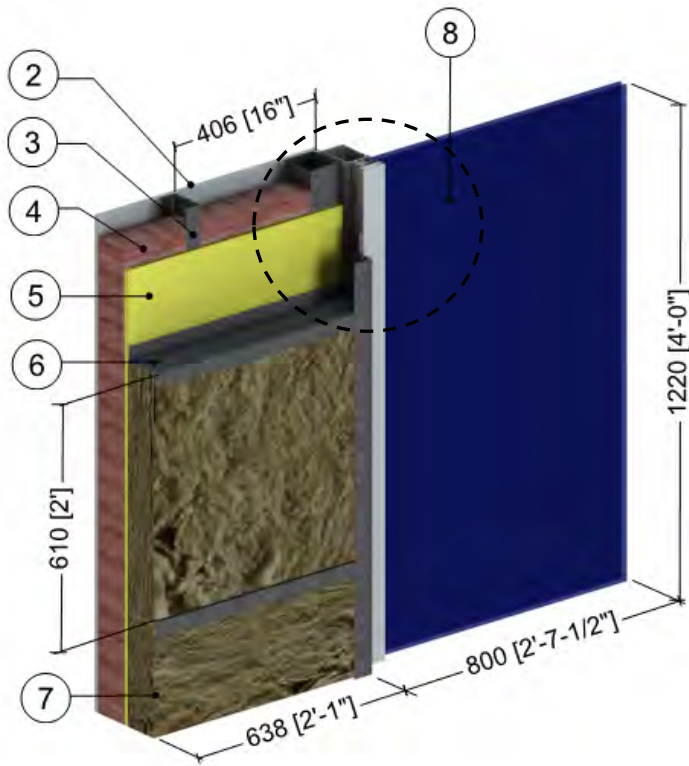

Without Aerogel Detail

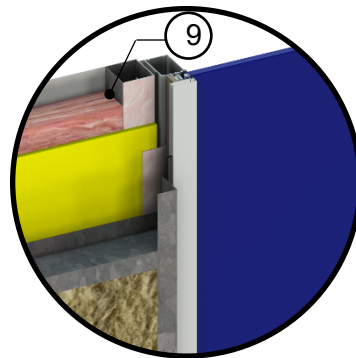

With Aerogel Detail

ID	Component	Thickness Inches (mm)	Conductivity Btu-in / ft ² ·hr·°F (W/m K)	Nominal Resistance hr·ft ² ·°F/Btu (m ² K/W)	Density lb/ft ³ (kg/m ³)	Specific Heat Btu/lb·°F (J/kg K)
1	Interior Films ¹	-	-	R-0.7 to R-1.1 (0.12 RSI to 0.20 RSI)	-	-
2	Gypsum Board	1/2" (13)	1.1 (0.16)	R-0.5 (0.08 RSI)	50 (800)	0.26 (1090)
3	3 5/8" x 1 5/8" Steel Studs	18 Gauge	430 (62)	-	489 (7830)	0.12 (500)
4	Fiberglass Batt Insulation	3 5/8" (92)	0.31 (0.044)	R-12 (2.1 RSI)	0.9 (14)	0.17 (710)
5	Exterior Sheathing	1/2" (13)	1.1 (0.16)	R-0.5 (0.08 RSI)	50 (800)	0.26 (1090)
6	Horizontal Z-girts w/ 1 1/2" Flange	18 Gauge	430 (62)	-	489 (7830)	0.12 (500)
7	Exterior Insulation	3 1/2" (89)	-	R-15 (2.64 RSI)	1.8 (28)	0.29 (1220)
8	Conventional curtain wall system: double glazed with minimal thermal break ² , double glazed IGU U _{IGU} = 0.32 BTU/hr·ft ² ·°F (1.82 W/m ² K)					
9	Aerogel Blanket	0.4" (10)	0.086 (0.015)	R-3.8 (0.67 RSI)	-	-
10	Exterior Film ¹	-	-	R-0.2 to R-0.7 (0.03 RSI to 0.12 RSI)	-	-

¹ Value selected from table 1, p. 26.1 of 2009 ASHRAE Handbook – Fundamentals depending on surface orientation

² The thermal conductivity of air spaces within framing was found using ISO 100077-2

Detail 5.4.4

Exterior and Interior Insulated 3 5/8" x 1 5/8" Steel Stud (16" o.c.) Wall Assembly with Horizontal Z-Girts (24" o.c.) Supporting Metal Cladding and R-12 Batt Insulation in Stud Cavity – Conventional Curtain Wall Intersection

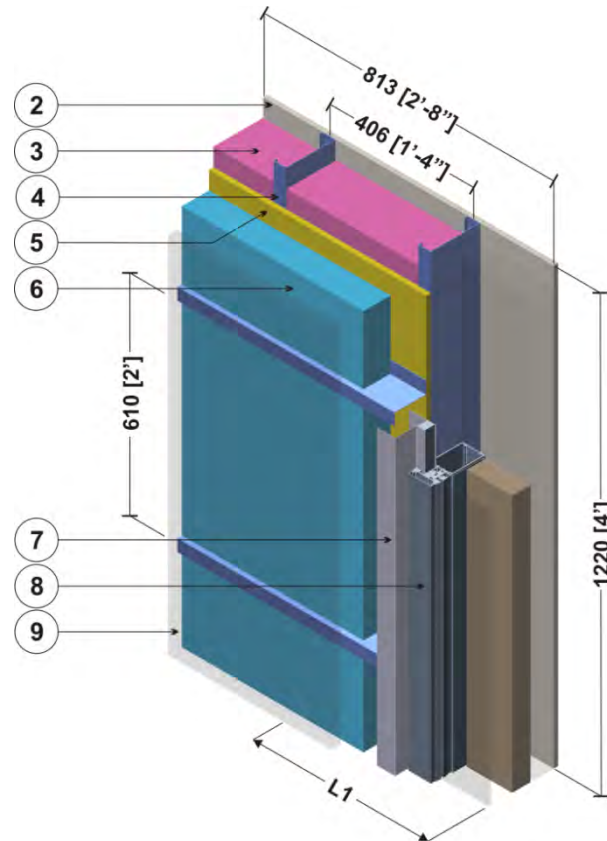

ID	Component	Thickness Inches (mm)	Conductivity Btu-in / ft ² ·hr·°F (W/m K)	Nominal Resistance hr·ft ² ·°F/Btu (m ² K/W)	Density lb/ft ³ (kg/m ³)	Specific Heat Btu/lb·°F (J/kg K)
1	Interior Film ¹	-	-	R-0.7 (0.12 RSI)	-	-
2	Gypsum Board	1/2" (13)	1.1 (0.16)	R-0.5 (0.08 RSI)	50 (800)	0.26 (1090)
3	Fiberglass Batt Insulation	3 5/8" (90)	0.31 (0.044)	R-12 (2.1 RSI)	0.9 (14)	0.17 (710)
4	3 5/8" x 1 5/8" Steel Studs	18 Gauge	430 (62)	-	489 (7830)	0.12 (500)
5	Exterior Sheathing	1/2" (13)	1.1 (0.16)	R-0.5 (0.08 RSI)	50 (800)	0.26 (1090)
6	Exterior Insulation	varies	-	R-5 to R-25 (0.88 RSI to 4.4 RSI)	1.8 (28)	0.29 (1220)
7	Horizontal Z-girts w/ 1 1/2" Flange with Closure Flashing	18 Gauge	430 (62)	-	489 (7830)	0.12 (500)
8	Conventional curtain wall system with insulated back pan (Pressure plates with minimal thermal break) ²					
9	Metal cladding with 1/2" (13mm) vented air space is incorporated into exterior heat transfer coefficient					
10	Exterior Film ¹	-	-	R-0.2 (0.03 RSI) to R-0.7 (0.12 RSI)	-	-

¹ Value selected from table 1, p. 26.1 of 2009 ASHRAE Handbook – Fundamentals depending on surface orientation

² The thermal conductivity of air spaces within curtain wall framing was found using ISO 10077-2

Detail 5.4.5

Exterior Insulated Concrete Wall and Steel Stud Assembly Supporting Metal Cladding – Curtain Wall Transition Intersection

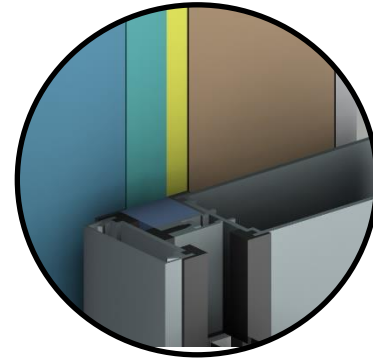
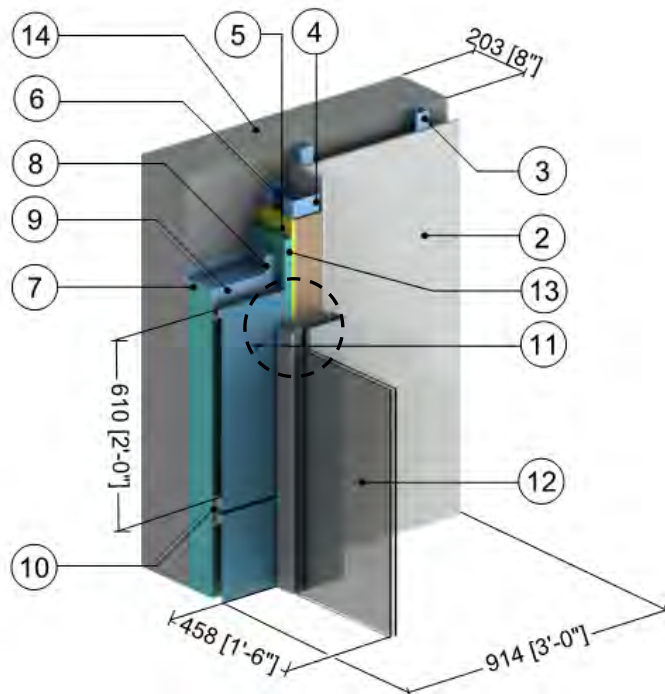

Jamb Detail

ID	Component	Thickness Inches (mm)	Conductivity Btu-in / ft ² -hr-°F (W/m K)	Nominal Resistance hr-ft ² -°F/Btu (m ² K/W)	Density lb/ft ³ (kg/m ³)	Specific Heat Btu/lb-°F (J/kg K)
1	Interior Film ¹	-	-	R-0.7 (0.12 RSI)	-	-
2	Gypsum Board	1/2" (13)	1.1 (0.16)	R-0.5 (0.08 RSI)	50 (800)	0.26 (1090)
3	1 5/8" x 1 5/8" Steel Studs	18 Gauge	430 (62)	-	489 (7830)	0.12 (500)
4	3 5/8" x 1 5/8" Steel Studs	18 Gauge	430 (62)	-	489 (7830)	0.12 (500)
5	Exterior Sheathing	1/2" (13)	1.1 (0.16)	R-0.5 (0.08 RSI)	50 (800)	0.26 (1090)
6	Air Cavity	3 5/8" (92)	-	R-0.9 (0.16 RSI)	0.075 (1.2)	0.24 (1000)
7	Exterior Insulation	Varies	-	R-15 to R-25 (2.64 RSI to 4.4 RSI)	1.8 (28)	0.29 (1220)
8	Vertical Z-Girt	18 Gauge	430 (62)	-	489 (7830)	0.12 (500)
9	Horizontal Z-Girt (24" o.c.)	18 Gauge	430 (62)	-	489 (7830)	0.12 (500)
10	Panel Clip	14 Gauge	430 (62)	-	489 (7830)	0.12 (500)
11	Metal Cladding with 1/2" (13mm) vented airspace incorporated into exterior heat transfer coefficient					
12	Conventional curtain wall system: double glazed with minimal thermal break ² , double glazed IGU $U_{IGU} = 0.32 \text{ BTU/hr-ft}^2\text{-}^\circ\text{F}$ (1.82 W/m ² K)					
13	Rigid Insulation	1" (25)	-	R-5.0 (0.88 RSI)	1.8 (28)	0.29 (1220)
14	Concrete Wall	8" (203)	12.5 (1.8)	-	140 (2250)	0.20 (850)
15	Exterior Film ¹	-	-	R-0.7 (0.12 RSI)	-	-

¹ Value selected from table 1, p. 26.1 of 2009 ASHRAE Handbook – Fundamentals depending on surface orientation

² The thermal conductivity of air spaces within framing was found using ISO 100077-2

Detail 5.4.6

Exterior Insulated Concrete Wall and Steel Stud Assembly Supporting Metal Cladding with Cavity Insulation – Curtain Wall Transition Intersection

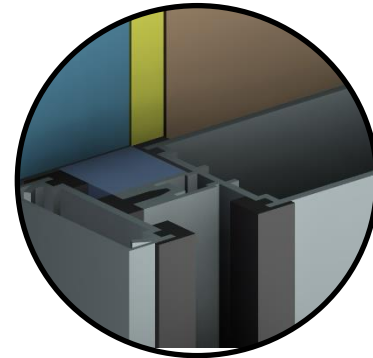
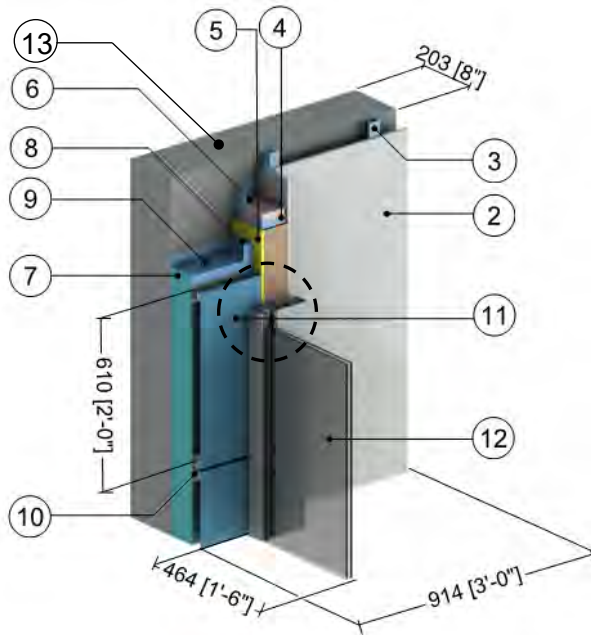

Jamb Detail

ID	Component	Thickness Inches (mm)	Conductivity Btu-in / ft ² ·hr·°F (W/m K)	Nominal Resistance hr·ft ² ·°F/Btu (m ² K/W)	Density lb/ft ³ (kg/m ³)	Specific Heat Btu/lb·°F (J/kg K)
1	Interior Films ¹	-	-	R-0.7 (0.12 RSI)	-	-
2	Gypsum Board	1/2" (13)	1.1 (0.16)	R-0.5 (0.08 RSI)	50 (800)	0.26 (1090)
3	1 5/8" x 1 5/8" Steel Studs	18 Gauge	430 (62)	-	489 (7830)	0.12 (500)
4	3 5/8" x 1 5/8" Steel Studs	18 Gauge	430 (62)	-	489 (7830)	0.12 (500)
5	Exterior Sheathing	1/2" (13)	1.1 (0.16)	R-0.5 (0.08 RSI)	50 (800)	0.26 (1090)
6	Fiberglass Batt Insulation	3 5/8" (92)	0.29 (0.042)	R-12.0 (2.1 RSI)	0.9 (14)	0.17 (710)
7	Exterior Insulation	Varies	-	R-15 to R-25 (2.64 RSI to 4.4 RSI)	1.8 (28)	0.29 (1220)
8	Vertical Z-Girt	18 Gauge	430 (62)	-	489 (7830)	0.12 (500)
9	Horizontal Z-Girt (24" o.c.)	18 Gauge	430 (62)	-	489 (7830)	0.12 (500)
10	Panel Clip	14 Gauge	430 (62)	-	489 (7830)	0.12 (500)
11	Metal Cladding with 1/2" (13mm) vented airspace incorporated into exterior heat transfer coefficient					
12	Conventional curtain wall system: double glazed with minimal thermal break ² , double glazed IGU U _{IGU} = 0.32 BTU/hr·ft ² ·°F (1.82 W/m ² K)					
13	Concrete Wall	8" (203)	12.5 (1.8)	-	140 (2250)	0.20 (850)
14	Exterior Film ¹	-	-	R-0.7 (0.12 RSI)	-	-

¹ Value selected from table 1, p. 26.1 of 2009 ASHRAE Handbook – Fundamentals depending on surface orientation

² The thermal conductivity of air spaces within framing was found using ISO 100077-2

Detail 5.5.1

Exterior Insulated 3 5/8" x 1 5/8" Steel Stud (16" o.c.) Drained EIFS Wall Assembly – Concrete Parapet & Slab Intersection

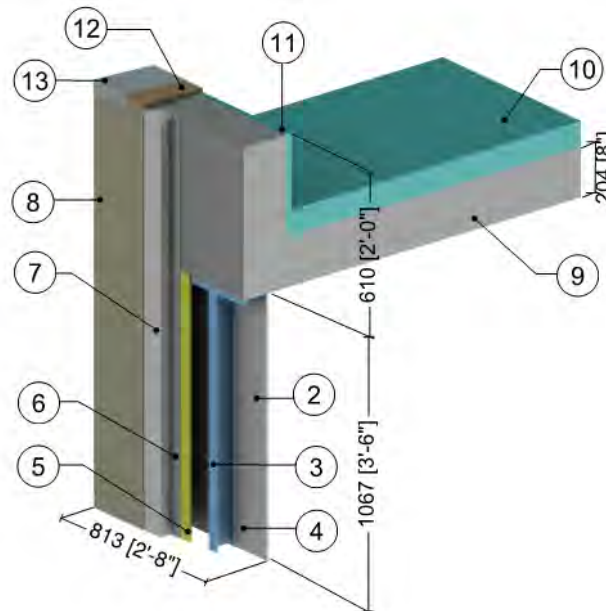

ID	Component	Thickness Inches (mm)	Conductivity Btu-in / ft ² -hr-°F (W/m K)	Nominal Resistance hr-ft ² -°F/Btu (m ² K/W)	Density lb/ft ³ (kg/m ³)	Specific Heat Btu/lb-°F (J/kg K)
1	Interior Films ¹	-	-	R-0.6 to R-0.9 (0.11 RSI to 0.16 RSI)	-	-
2	Gypsum Board	1/2" (13)	1.1 (0.16)	R-0.5 (0.08 RSI)	50 (800)	0.26 (1090)
3	3 5/8" x 1 5/8" Steel Studs (16"o.c.) with Top Tracks	18 Gauge	430 (62)	-	489 (7830)	0.12 (500)
4	Air in Stud Cavity	3 5/8" (92)	-	R-0.9 (0.16 RSI)	0.075 (1.2)	0.24 (1000)
5	Exterior Sheathing	1/2" (13)	1.1 (0.16)	R-0.5 (0.08 RSI)	50 (800)	0.26 (1090)
6	Weather Resistive Barrier with Adhesive	-	-	-	-	-
7	Insulation Board	Varies	0.27 (0.039)	R-7.5 to R-15 (1.32 RSI to 2.64 RSI)	1 (16)	0.35 (1470)
8	Lamina	1/8" (4)	6 (0.9)	R-0.04 (0.01 RSI)	120 (1922)	0.20 (850)
9	Concrete Slab & Parapet	8" (203)	12 (1.8)	-	140 (2250)	0.20 (850)
10	Roof Insulation	4" (100)	-	R-20 (3.5 RSI)	1.8 (28)	0.29 (1220)
11	Parapet Insulation	1" (25)	-	R-5 (0.88 RSI)	1.8 (28)	0.29 (1220)
12	Wood Blocking	5/8" (16)	0.63 (0.09)	-	27.8 (445)	0.45 (1880)
13	Flashing & roof finish material are incorporated into exterior heat transfer coefficient					
14	Exterior Film ¹	-	-	R-0.2 to R-0.7 (0.03 RSI to 0.12 RSI)	-	-

¹ Value selected from table 1, p. 26.1 of 2009 ASHRAE Handbook – Fundamentals depending on surface orientation

Detail 5.5.2

Exterior Insulated 3 5/8" x 1 5/8" Steel Stud (16" o.c.) Drained EIFS Wall Assembly – Insulated Concrete Parapet & Slab Intersection

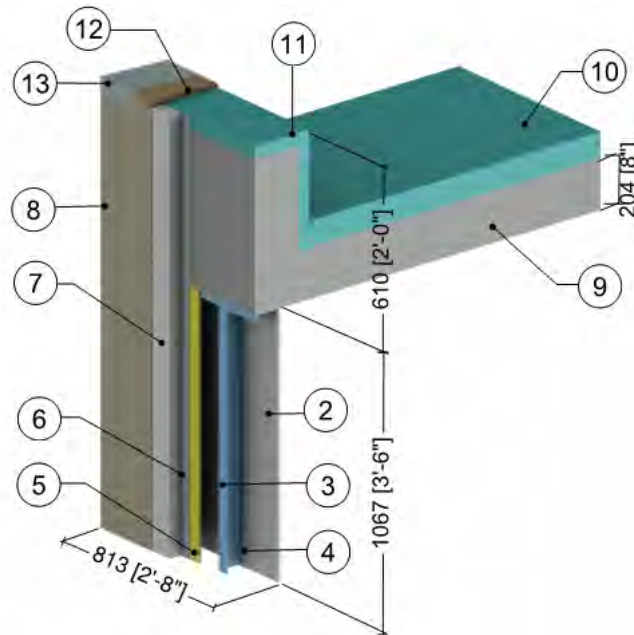

ID	Component	Thickness Inches (mm)	Conductivity Btu-in / ft ² -hr-°F (W/m K)	Nominal Resistance hr-ft ² -°F/Btu (m ² K/W)	Density lb/ft ³ (kg/m ³)	Specific Heat Btu/lb-°F (J/kg K)
1	Interior Films ¹	-	-	R-0.6 to R-0.9 (0.12 RSI to 0.16 RSI)	-	-
2	Gypsum Board	1/2" (13)	1.1 (0.16)	R-0.5 (0.08 RSI)	50 (800)	0.26 (1090)
3	3 5/8" x 1 5/8" Steel Studs (16" o.c.) with Top Tracks	18 Gauge	430 (62)	-	489 (7830)	0.12 (500)
4	Air in Stud Cavity	3 5/8" (92)	-	R-0.9 (0.16 RSI)	0.075 (1.2)	0.24 (1000)
5	Exterior Sheathing	1/2" (13)	1.1 (0.16)	R-0.5 (0.08 RSI)	50 (800)	0.26 (1090)
6	Weather Resistive Barrier with Adhesive	-	-	-	-	-
7	Insulation Board	Varies	0.27 (0.039)	R-7.5 to R-15 (1.32 RSI to 2.64 RSI)	1 (16)	0.35 (1470)
8	Lamina	1/8" (4)	6 (0.9)	R-0.04 (0.01 RSI)	120 (1922)	0.20 (850)
9	Concrete Slab & Parapet	8" (203)	12.5 (1.8)	-	140 (2250)	0.20 (850)
10	Roof Insulation	4" (100)	-	R-20 (3.5 RSI)	1.8 (28)	0.29 (1220)
11	Parapet Insulation	Varies	-	R-10 to R-20 (1.76 RSI to 3.52 RSI)	1.8 (28)	0.29 (1220)
12	Wood Blocking	5/8" (16)	0.63 (0.09)	-	27.8 (445)	0.45 (1880)
13	Flashing & roof finish material are incorporated into exterior heat transfer coefficient					
14	Exterior Film ¹	-	-	R-0.2 to R-0.7 (0.03 RSI to 0.12 RSI)	-	-

¹ Value selected from table 1, p. 26.1 of 2009 ASHRAE Handbook – Fundamentals depending on surface orientation

Detail 5.5.3

Exterior and Interior Insulated 3 5/8" x 1 5/8" Steel Stud (16" o.c.) Drained EIFS Wall Assembly with R-12 Batt Insulation in Stud Cavity – Concrete Parapet & Slab Intersection

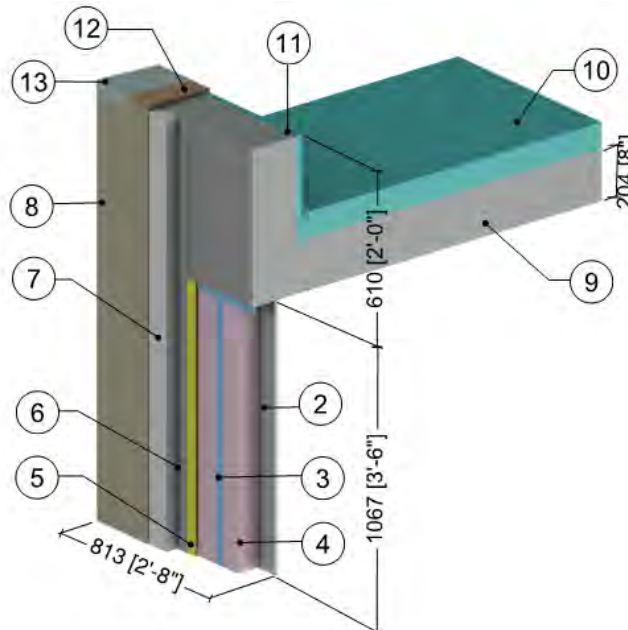

ID	Component	Thickness Inches (mm)	Conductivity Btu-in / ft ² -hr-°F (W/m K)	Nominal Resistance hr-ft ² -°F/Btu (m ² K/W)	Density lb/ft ³ (kg/m ³)	Specific Heat Btu/lb-°F (J/kg K)
1	Interior Films ¹	-	-	R-0.6 to R-0.9 (0.11 RSI to 0.16 RSI)	-	-
2	Gypsum Board	1/2" (13)	1.1 (0.16)	R-0.5 (0.08 RSI)	50 (800)	0.26 (1090)
3	3 5/8" x 1 5/8" Steel Studs (16" o.c.) with Top Tracks	18 Gauge	430 (62)	-	489 (7830)	0.12 (500)
4	Fiberglass Batt Insulation	3 5/8" (92)	0.31 (0.044)	R-12 (2.1 RSI)	0.9 (1.1)	0.17 (710)
5	Exterior Sheathing	1/2" (13)	1.1 (0.16)	R-0.5 (0.08 RSI)	50 (800)	0.26 (1090)
6	Weather Resistant Barrier with Adhesive	-	-	-	-	-
7	Insulation Board	Varies	0.27 (0.039)	R-7.5 to R-15 (1.32 RSI to 2.64 RSI)	1 (16)	0.35 (1470)
8	Lamina	1/8" (4)	6 (0.9)	R-0.04 (0.01 RSI)	120 (1922)	0.20 (850)
9	Concrete Slab & Parapet	8" (203)	12.5 (1.8)	-	140 (2250)	0.20 (850)
10	Roof Insulation	4" (100)	-	R-20 (3.5 RSI)	1.8 (28)	0.29 (1220)
11	Parapet Insulation	1" (25)	-	R-5 (0.88 RSI)	1.8 (28)	0.29 (1220)
12	Wood Blocking	5/8" (16)	0.63 (0.09)	-	27.8 (445)	0.45 (1880)
13	Flashing & roof finish material are incorporated into exterior heat transfer coefficient					
14	Exterior Film ¹	-	-	R-0.2 to R-0.7 (0.03 RSI to 0.12 RSI)	-	-

¹ Value selected from table 1, p. 26.1 of 2009 ASHRAE Handbook – Fundamentals depending on surface orientation

Detail 5.5.4

Exterior and Interior Insulated 3 5/8" x 1 5/8" Steel Stud (16" o.c.) Drained EIFS Wall Assembly with R-12 Batt Insulation in Stud Cavity – Insulated Concrete Parapet & Slab Intersection

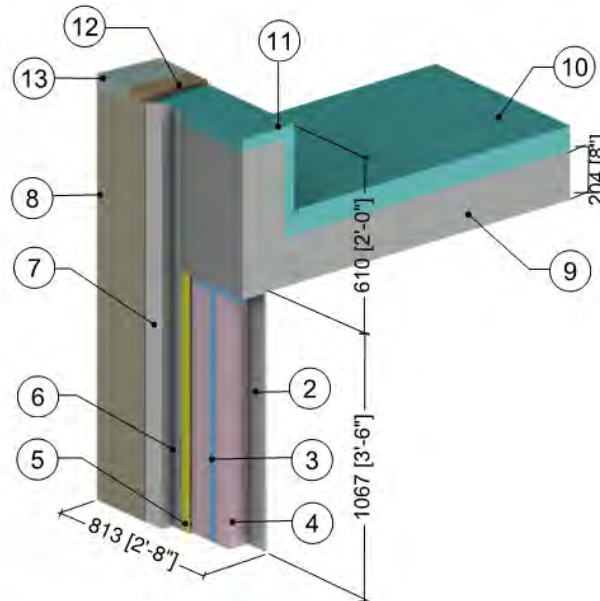

ID	Component	Thickness Inches (mm)	Conductivity Btu-in / ft ² ·hr·°F (W/m K)	Nominal Resistance hr·ft ² ·°F/Btu (m ² K/W)	Density lb/ft ³ (kg/m ³)	Specific Heat Btu/lb·°F (J/kg K)
1	Interior Films ¹	-	-	R-0.6 to R-0.9 (0.12 RSI to 0.16 RSI)	-	-
2	Gypsum Board	1/2" (13)	1.1 (0.16)	R-0.5 (0.08 RSI)	50 (800)	0.26 (1090)
3	3 5/8" x 1 5/8" Steel Studs (16" o.c.) with Top Tracks	18 Gauge	430 (62)	-	489 (7830)	0.12 (500)
4	Fiberglass Batt Insulation	3 5/8" (92)	0.31 (0.044)	R-12 (2.1 RSI)	0.9 (1.1)	0.17 (710)
5	Exterior Sheathing	1/2" (13)	1.1 (0.16)	R-0.5 (0.08 RSI)	50 (800)	0.26 (1090)
6	Weather Resistant Barrier with Adhesive	-	-	-	-	-
7	Insulation Board	Varies	0.27 (0.039)	R-7.5 to R-15 (1.32 RSI to 2.64 RSI)	1 (16)	0.35 (1470)
8	Lamina	1/8" (4)	6 (0.9)	R-0.04 (0.01 RSI)	120 (1922)	0.20 (850)
9	Concrete Slab & Parapet	8" (203)	12 (1.8)	-	140 (2250)	0.20 (850)
10	Roof Insulation	4" (100)	-	R-20 (3.5 RSI)	1.8 (28)	0.29 (1220)
11	Parapet Insulation	Varies	-	R-10 to R-20 (1.76 RSI to 3.52 RSI)	1.8 (28)	0.29 (1220)
12	Wood Blocking	5/8" (16)	0.63 (0.09)	R-1 (0.18 RSI)	27.8 (445)	0.45 (1880)
13	Flashing & roof finish material are incorporated into exterior heat transfer coefficient					
14	Exterior Film ¹	-	-	R-0.2 to R-0.7 (0.03 RSI to 0.12 RSI)	-	-

¹ Value selected from table 1, p. 26.1 of 2009 ASHRAE Handbook – Fundamentals depending on surface orientation

Detail 5.5.5

Exterior Insulated 3 5/8" x 1 5/8" Steel Stud (16" o.c.) Wall Assembly with Horizontal Z-Girts (24" o.c.) Supporting Metal Cladding – Concrete Parapet & Slab Intersection

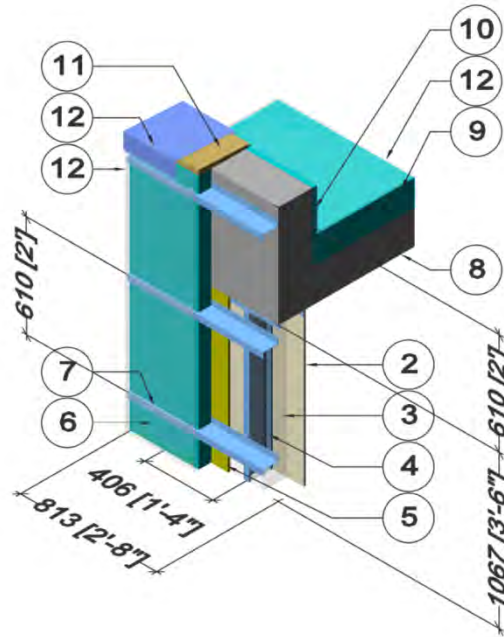

ID	Component	Thickness Inches (mm)	Conductivity Btu-in / ft ² ·hr·°F (W/m K)	Nominal Resistance hr·ft ² ·°F/Btu (m ² K/W)	Density lb/ft ³ (kg/m ³)	Specific Heat Btu/lb·°F (J/kg K)
1	Interior Film ¹	-	-	R-0.6 to R-0.7 (0.11 RSI to 0.12 RSI)	-	-
2	Gypsum Board	1/2" (13)	1.1 (0.16)	R-0.5 (0.08 RSI)	50 (800)	0.26 (1090)
3	Air in Stud Cavity	3 5/8" (92)	-	R-0.9 (0.16 RSI)	0.075 (1.2)	0.24 (1000)
4	3 5/8" x 1 5/8" Steel Studs with Top and Bottom Track	18 Gauge	430 (62)	-	489 (7830)	0.12 (500)
5	Exterior Sheathing	1/2" (13)	1.1 (0.16)	R-0.5 (0.08 RSI)	50 (800)	0.26 (1090)
6	Exterior Insulation	Varies	-	R5 to R25 (0.88 to 4.4 RSI)	1.8 (28)	0.29 (1220)
7	Horizontal Z-Girts w/ 1 1/2" Flange	18 Gauge	430 (62)	-	489 (7830)	0.12 (500)
8	Concrete Slab & Parapet	8" (203)	12.5 (1.8)	-	140 (2250)	0.20 (850)
9	Roof Insulation	4" (102)	-	R-20 (3.5 RSI)	1.8 (28)	0.29 (1220)
10	Parapet Insulation	1" (25)	-	R-5 (0.88 RSI)	1.8 (28)	0.29 (1220)
11	Wood Blocking	5/8" (16)	0.63 (0.09)	R-1 (0.18 RSI)	27.8 (445)	0.45 (1880)
12	Metal cladding with 1/2" (13mm) vented air space is incorporated into exterior heat transfer coefficient, metal cap flashing & finish roof materials					
13	Exterior Film ¹	-	-	R-0.2 to R-0.7 (0.03 RSI to 0.12 RSI)	-	-

¹ Value selected from table 1, p. 26.1 of 2009 ASHRAE Handbook – Fundamentals depending on surface orientation

Detail 5.5.6

Exterior and Interior Insulated 3 5/8" x 1 5/8" Steel Stud (16" o.c.) Wall Assembly with Horizontal Z-girts (24" o.c.) Supporting Metal Cladding and R-12 Batt Insulation in Stud Cavity – Concrete Parapet and Slab Intersection

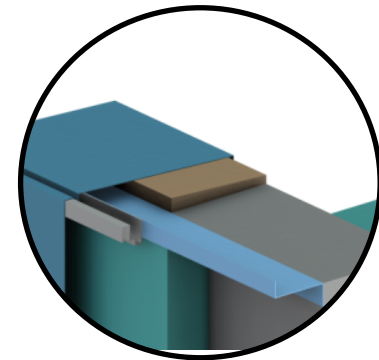
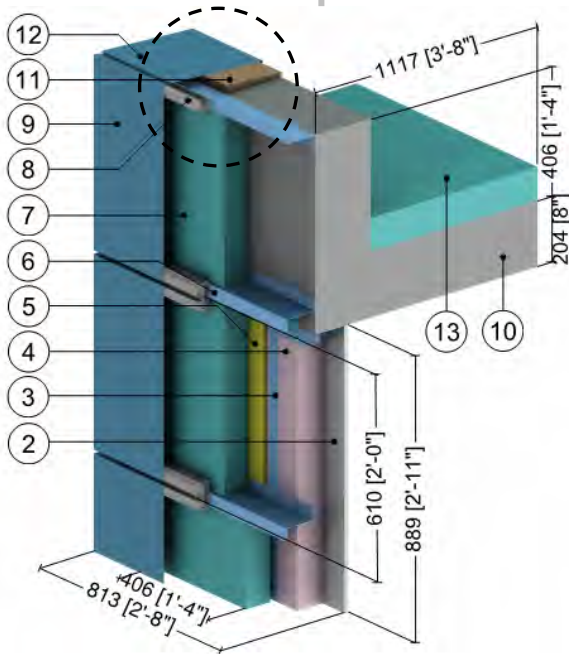

Parapet Cap Detail

ID	Component	Thickness Inches (mm)	Conductivity Btu-in / ft ² ·hr·°F (W/m K)	Nominal Resistance hr·ft ² ·°F/Btu (m ² K/W)	Density lb/ft ³ (kg/m ³)	Specific Heat Btu/lb·°F (J/kg K)
1	Interior Films ¹	-	-	R-0.6 to R-0.7 (0.11 RSI to 0.12 RSI)	-	-
2	Gypsum Board	1/2" (13)	1.1 (0.16)	R-0.5 (0.08 RSI)	50 (800)	0.26 (1090)
3	3 5/8" x 1 5/8" Steel Studs with Top Tracks	18 Gauge	430 (62)	-	489 (7830)	0.12 (500)
4	Fiberglass Batt Insulation	3 5/8" (92)	0.31 (0.044)	R-12 (2.1 RSI)	0.9 (14)	0.17 (710)
5	Exterior Sheathing	1/2" (13)	1.1 (0.16)	R-0.5 (0.08 RSI)	50 (800)	0.26 (1090)
6	Horizontal Z-girts w/ 1 1/2" Flange	18 Gauge	430 (62)	-	489 (7830)	0.12 (500)
7	Exterior Insulation	Varies	-	R-10 to R-15 (1.76 RSI to 2.64 RSI)	1.8 (28)	0.29 (1220)
8	Panel Clip	14 Gauge	430 (62)	-	489 (7830)	0.12 (500)
9	Metal Cladding with 1/2" vented airspace incorporated into exterior heat transfer coefficient					
10	Concrete Slab and Parapet	8" (203)	12.5 (1.8)	-	140 (2250)	0.20 (850)
11	Wood Blocking	5/8" (16)	0.69 (0.10)	R-1 (RSI-0.18)	31 (500)	0.45 (1880)
12	Steel Cap Flashing	18 Gauge	430 (62)	-	489 (7830)	0.12 (500)
13	Roof Insulation	4" (102)	0.20 (0.029)	R-20 (3.5 RSI)	1.8 (28)	0.29 (1220)
14	Exterior Film ¹	-	-	R-0.2 to R-0.7 (0.03 RSI to 0.12 RSI)	-	-

¹ Value selected from table 1, p. 26.1 of 2009 ASHRAE Handbook – Fundamentals depending on surface orientation

Detail 5.5.7

Exterior and Interior Insulated 3 5/8" x 1 5/8" Steel Stud (16" o.c.) Wall Assembly with Vertical Z Girts (16" o.c.) Supporting Stucco Cladding and R-12 Batt Insulation in Stud Cavity – Concrete Parapet & Slab Intersection

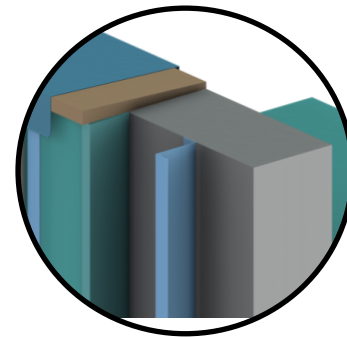
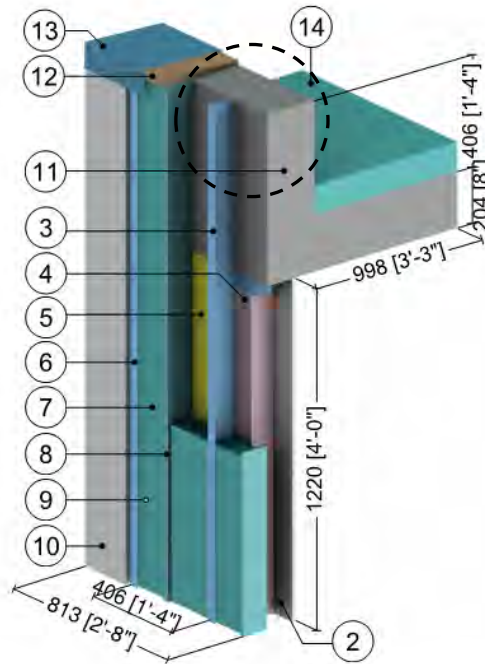

Parapet Cap Detail

ID	Component	Thickness Inches (mm)	Conductivity Btu-in / ft ² -hr-°F (W/m K)	Nominal Resistance hr-ft ² -°F/Btu (m ² K/W)	Density lb/ft ³ (kg/m ³)	Specific Heat Btu/lb-°F (J/kg K)
1	Interior Film ¹	-	-	R-0.6 to R-0.7 (0.11 RSI to 0.12 RSI)	-	-
2	Gypsum Board	1/2" (13)	1.1 (0.16)	R-0.5 (0.08 RSI)	50 (800)	0.26 (1090)
3	3 5/8" x 1 5/8" Steel Studs with Top Tracks	18 Gauge	430 (62)	-	489 (7830)	0.12 (500)
4	Fiberglass Batt Insulation	3 5/8" (92)	0.31 (0.044)	R-12 (2.1 RSI)	0.9 (14)	0.17 (710)
5	Exterior Sheathing	1/2" (13)	1.1 (0.16)	R-0.5 (0.08 RSI)	50 (800)	0.26 (1090)
6	Vertical Z-Girts with 1 1/2" Flange	18 Gauge	430 (62)	-	489 (7830)	0.12 (500)
7	Exterior Insulation	Varies	-	R-10 to R-15 (1.76 RSI to 2.64 RSI)	1.8 (28)	0.29 (1220)
8	Rigid Insulation Bracing	Varies	0.2 (0.029)	-	1.8 (28)	0.29 (1220)
9	Rainscreen Cavity	1/2" (13)	-	R-0.5 (0.09 RSI)	0.075 (1.2)	0.24 (1000)
10	Stucco Cement with Breather Board	1/2" (13)	6 (0.9)	R-0.1 (0.01 RSI)	120 (1922)	0.20 (850)
11	Concrete Slab and Parapet	8" (203)	12.5 (1.8)	-	140 (2250)	0.20 (850)
12	Wood Blocking	5/8" (16)	0.69 (0.10)	-	31 (500)	0.45 (1880)
13	Steel Cap Flashing	18 Gauge	430 (62)	-	489 (7830)	0.12 (500)
14	Roof Insulation	4 (102)	0.20 (0.029)	R-20 (3.5 RSI)	1.8 (28)	0.29 (1220)
15	Exterior Film ¹	-	-	R-0.2 (0.03 RSI)	-	-

¹ Value selected from table 1, p. 26.1 of 2009 ASHRAE Handbook – Fundamentals depending on surface orientation

Detail 5.5.8

**Exterior and Interior Insulated 3 5/8" x 1 5/8" Steel Stud (16" o.c.)
Wall Assembly with Intermittent Vertical Z Girts (16" o.c.)
Supporting Metal Cladding and R-12 Batt Insulation in Stud Cavity –
Concrete Roof Deck at Continuous Concrete Parapet**

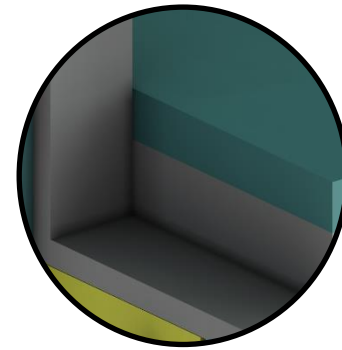
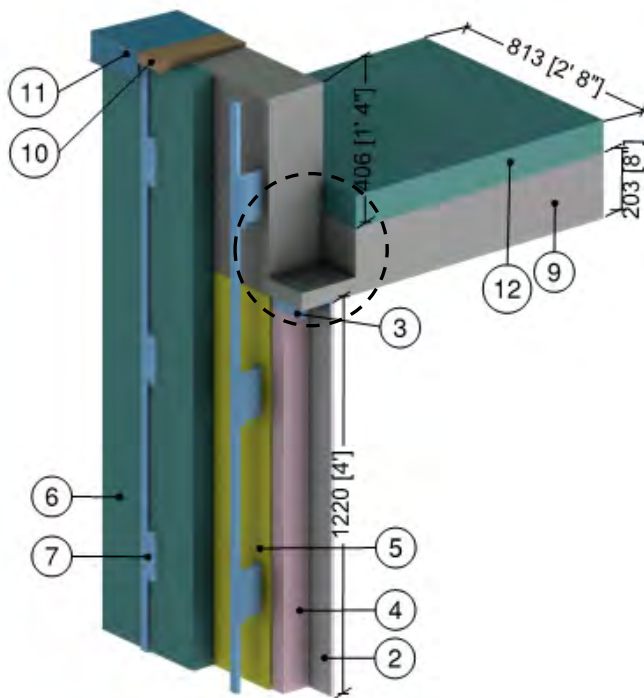

Continuous Concrete Parapet Detail

ID	Component	Thickness Inches (mm)	Conductivity Btu-in / ft ² -hr-°F (W/m K)	Nominal Resistance hr-ft ² -°F/Btu (m ² K/W)	Density lb/ft ³ (kg/m ³)	Specific Heat Btu/lb-°F (J/kg K)
1	Interior Film ¹	-	-	R-0.6 to R-0.7 (0.11 RSI to 0.12 RSI)	-	-
2	Gypsum Board	1/2" (13)	1.1 (0.16)	R-0.5 (0.08 RSI)	50 (800)	0.26 (1090)
3	3 5/8" x 1 5/8" Steel Studs with Top Tracks	18 Gauge	430 (62)	-	489 (7830)	0.12 (500)
4	Fiberglass Batt Insulation	3 5/8" (92)	0.31 (0.044)	R-12.0 (2.11 RSI)	0.9 (14)	0.17 (710)
5	Exterior Sheathing	1/2" (13)	1.1 (0.16)	R-0.5 (0.08 RSI)	50 (800)	0.26 (1090)
6	Exterior Insulation	3" (76)	-	R-15 (2.64 RSI)	1.8 (28)	0.29 (1220)
7	Intermittent Vertical Z-Girts with 1 1/2" Flange	18 Gauge	430 (62)	-	489 (7830)	0.12 (500)
8	Metal Cladding with 1/2" vented airspace incorporated into exterior heat transfer coefficient					
9	Concrete Slab and Parapet	8" (203)	12.5 (1.8)	-	140 (2250)	0.20 (850)
10	Wood Blocking	5/8" (16)	0.69 (0.10)	R-1.0 (0.18 RSI)	31 (500)	0.45 (1880)
11	Steel Cap Flashing	18 Gauge	347 (50)	-	489 (7830)	0.12 (500)
12	Roof Insulation	4 (102)	0.20 (0.029)	R-20 (3.50 RSI)	1.8 (28)	0.29 (1220)
13	Flashing & roof finish material are incorporated into exterior heat transfer coefficient					
14	Exterior Film ¹	-	-	R-0.2 to R-0.7 (0.03 RSI to 0.12 RSI)	-	-

¹ Value selected from table 1, p. 26.1 of 2009 ASHRAE Handbook – Fundamentals depending on surface orientation

Detail 5.5.9

Exterior and Interior Insulated 3 5/8" x 1 5/8" Steel Stud (16" o.c.) Wall Assembly with Intermittent Vertical Z Girts (16" o.c.) Supporting Metal Cladding and R-12 Batt Insulation in Stud Cavity – Concrete Roof Deck at Isokorb AXT1 Thermally Broken Concrete Parapet

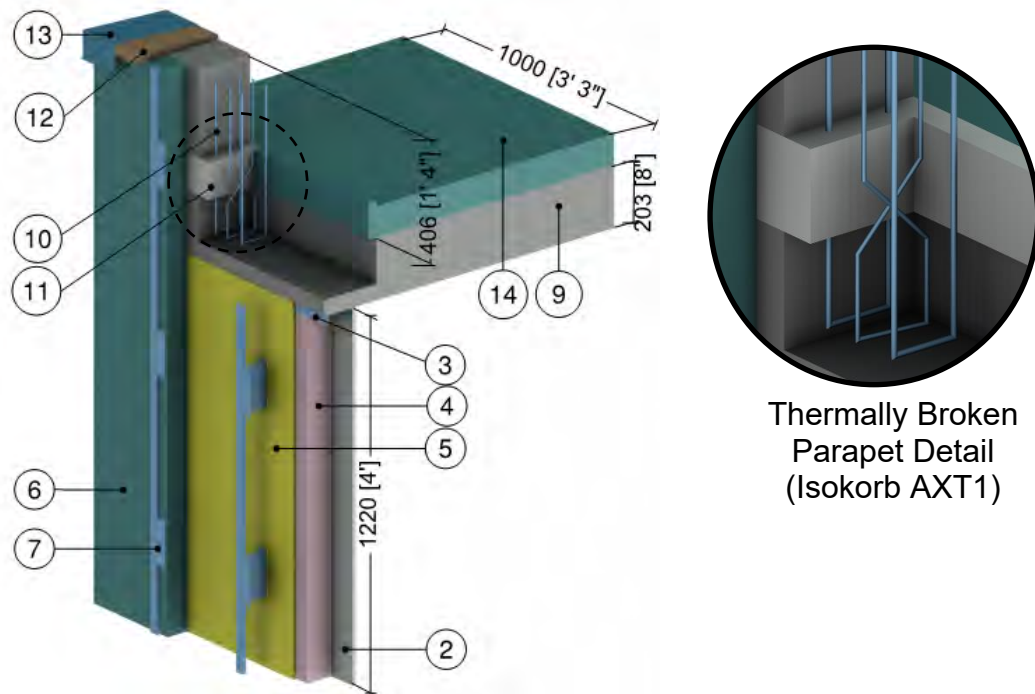

Thermally Broken Parapet Detail (Isokorb AXT1)

ID	Component	Thickness Inches (mm)	Conductivity Btu-in / ft ² ·hr·°F (W/m K)	Nominal Resistance hr·ft ² ·°F/Btu (m ² K/W)	Density lb/ft ³ (kg/m ³)	Specific Heat Btu/lb·°F (J/kg K)
1	Interior Film ¹	-	-	R-0.6 (0.11 RSI) to R-0.7 (0.12 RSI)	-	-
2	Gypsum Board	1/2" (13)	1.1 (0.16)	R-0.5 (0.08 RSI)	50 (800)	0.26 (1090)
3	3 5/8" x 1 5/8" Steel Studs with Top Tracks	18 Gauge	430 (62)	-	489 (7830)	0.12 (500)
4	Fiberglass Batt Insulation	3 5/8" (92)	0.31 (0.044)	R-12.0 (2.11 RSI)	0.9 (14)	0.17 (710)
5	Exterior Sheathing	1/2" (13)	1.1 (0.16)	R-0.5 (0.08 RSI)	50 (800)	0.26 (1090)
6	Exterior Insulation	3" (76)	-	R-15 (2.64 RSI)	1.8 (28)	0.29 (1220)
7	Intermittent Vertical Z-Girts with 1 1/2" Flange	18 Gauge	430 (62)	-	489 (7830)	0.12 (500)
8	Metal Cladding with 1/2" vented airspace incorporated into exterior heat transfer coefficient					
9	Concrete Slab and Parapet	8" (203)	12.5 (1.8)	-	140 (2250)	0.20 (850)
10	Stainless Steel Rebar	-	118 (17)	-	500 (8000)	0.12 (500)
11	Polystyrene Hard Foam Insulation	4 3/4" (120)	0.217 (0.031)	R-22.0 (3.87 RSI)	66 (1060)	0.35 (1500)
12	Wood Blocking	5/8" (16)	0.69 (0.10)	R-1.0 (0.18 RSI)	31 (500)	0.45 (1880)
13	Steel Cap Flashing	18 Gauge	347 (50)	-	489 (7830)	0.12 (500)
14	Roof Insulation	4 (102)	0.20 (0.029)	R-20 (3.50 RSI)	1.8 (28)	0.29 (1220)
15	Flashing & roof finish material are incorporated into exterior heat transfer coefficient					
16	Exterior Film ¹	-	-	R-0.2 (0.03 RSI) to R-0.7 (0.12 RSI)	-	-

¹ Value selected from table 1, p. 26.1 of 2009 ASHRAE Handbook – Fundamentals depending on surface orientation

Detail 5.5.10

Exterior and Interior Insulated 3 5/8" x 1 5/8" Steel Stud (16" o.c.) Wall Assembly with Horizontal Z-Girts (24" o.c.) Supporting Metal Cladding and R-12 Batt Insulation in Stud Cavity – Steel Roof Deck with Open Web Steel Joist & Parapet Intersection

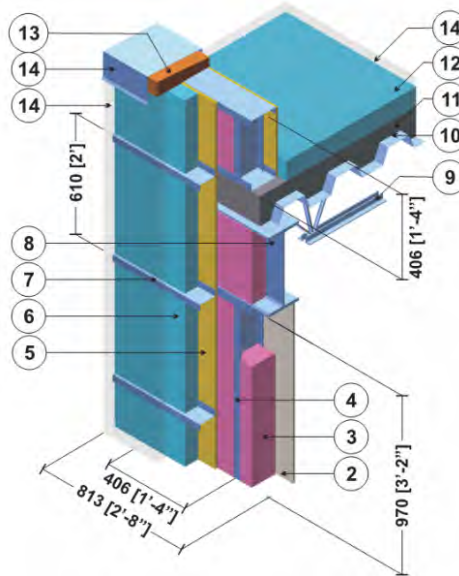

ID	Component	Thickness Inches (mm)	Conductivity Btu-in / ft ² ·hr·°F (W/m K)	Nominal Resistance hr·ft ² ·°F/Btu (m ² K/W)	Density lb/ft ³ (kg/m ³)	Specific Heat Btu/lb·°F (J/kg K)
1	Interior Film ¹	-	-	R-0.6 to R-0.7 (0.11 RSI to 0.12 RSI)	-	-
2	Gypsum Board	1/2" (13)	1.1 (0.16)	R-0.5 (0.08 RSI)	50 (800)	0.26 (1090)
3	Fiberglass Batt Insulation	3 5/8" (92)	0.29 (0.042)	R-12 (2.1 RSI)	0.9 (14)	0.17 (710)
4	3 5/8" x 1 5/8" Steel Studs with Top and Bottom Tracks	18 Gauge	430 (62)	-	489 (7830)	0.12 (500)
5	Exterior Sheathing	1/2" (13)	1.1 (0.16)	R-0.5 (0.08 RSI)	50 (800)	0.26 (1090)
6	Exterior Insulation	varies	-	R5 to R25 (0.88 to 4.4 RSI)	1.8 (28)	0.29 (1220)
7	Horizontal Z-girts w/ 1 1/2" Flange	18 Gauge	430 (62)	-	489 (7830)	0.12 (500)
8	Steel Beam (W410)	-	347 (50)	-	489 (7830)	0.12 (500)
9	Open Web Steel Joist	-	347 (50)	-	489 (7830)	0.12 (500)
10	Steel Deck	1/16" (1.6)	347 (50)	-	489 (7830)	0.12 (500)
11	Concrete Topping	6" (152)	6.3 (0.9)	-	120 (1920)	0.20 (850)
12	Roof Insulation	4" (102)	-	R-20 (3.5 RSI)	1.8 (28)	0.29 (1220)
13	Wood Blocking	5/8" (16)	0.63 (0.09)	R-1 (0.18 RSI)	27.8 (445)	0.45 (1880)
14	Metal cladding with 1/2" (13mm) vented air space/ metal cap flashing/ finish roof materials is incorporated into exterior heat transfer coefficient					
15	Exterior Film ¹	-	-	R-0.2 to R-0.7 (0.03 RSI to 0.12 RSI)	-	-

¹ Value selected from table 1, p. 26.1 of 2009 ASHRAE Handbook – Fundamentals depending on surface orientation

Detail 5.5.11

Exterior and Interior Insulated 3 5/8" x 1 5/8" Steel Stud (16" o.c.) Wall Assembly with Horizontal Z-Girts (24" o.c.) Supporting Metal Cladding and R-12 Batt Insulation in Stud Cavity – Steel Roof Deck with Open Web Steel Joist & Parapet Intersection with Thermal Break under Parapet Stud Cavity

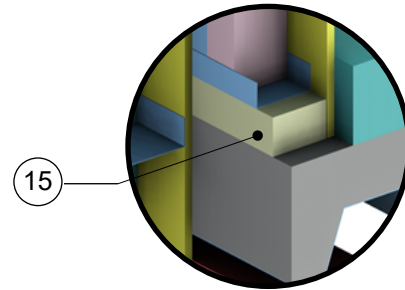
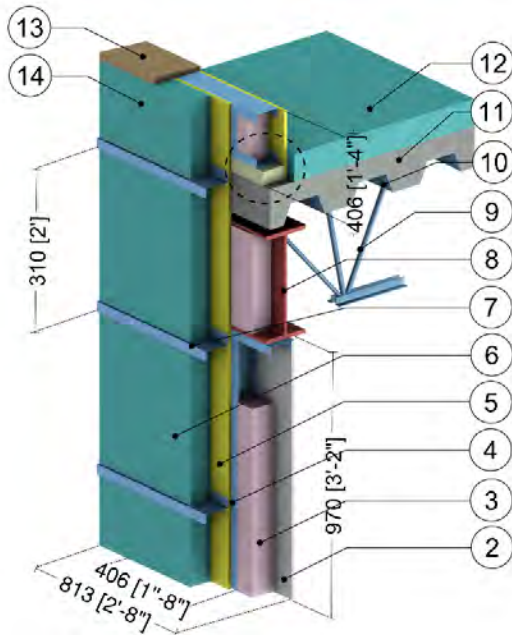

Parapet Thermal Break

ID	Component	Thickness Inches (mm)	Conductivity Btu-in / ft ² -hr-°F (W/m K)	Nominal Resistance hr-ft ² -°F/Btu (m ² K/W)	Density lb/ft ³ (kg/m ³)	Specific Heat Btu/lb-°F (J/kg K)
1	Interior Film ¹	-	-	R-0.6 to R-0.7 (0.11 RSI to 0.12 RSI)	-	-
2	Gypsum Board	1/2" (13)	1.1 (0.16)	R-0.5 (0.08 RSI)	50 (800)	0.26 (1090)
3	Fiberglass Batt Insulation	3 5/8" (92)	0.31 (0.044)	R-12 (2.1 RSI)	0.9 (14)	0.17 (710)
4	3 5/8" x 1 5/8" Steel Studs with Top and Bottom Tracks	18 Gauge	430 (62)	-	489 (7830)	0.12 (500)
5	Exterior Sheathing	1/2" (13)	1.1 (0.16)	R-0.5 (0.08 RSI)	50 (800)	0.26 (1090)
6	Exterior Insulation	varies	-	R15 (2.64 RSI)	1.8 (28)	0.29 (1220)
7	Horizontal Z-girts w/ 1 1/2" Flange	18 Gauge	430 (62)	-	489 (7830)	0.12 (500)
8	Steel Beam (W410)	-	347 (50)	-	489 (7830)	0.12 (500)
9	Open Web Steel Joist	-	347 (50)	-	489 (7830)	0.12 (500)
10	Steel Deck	1/16" (1.6)	347 (50)	-	489 (7830)	0.12 (500)
11	Concrete Topping	6" (152)	6.3 (0.9)	-	120 (1920)	0.20 (850)
12	Roof Insulation	4" (102)	-	R-20 (3.5 RSI)	1.8 (28)	0.29 (1220)
13	Wood Blocking	5/8" (16)	0.63 (0.09)	R-1 (0.18 RSI)	27.8 (445)	0.45 (1880)
14	Metal cladding with vented air space/ cap flashing/ finish roof materials is incorporated into exterior heat transfer coefficient					
15	Armatherm 500	2" (50)	0.32 (0.05)	R-6.2 (1.09 RSI)	-	-
16	Exterior Film ¹	-	-	R-0.2 to R-0.7 (0.03 RSI to 0.12 RSI)	-	-

¹ Value selected from table 1, p. 26.1 of 2009 ASHRAE Handbook – Fundamentals depending on surface orientation

Detail 5.5.12

Owens Corning Exterior Insulated 6" x 1 5/8" Steel Stud (16" o.c.) Wall Assembly with Thermally Isolated Vertical Brackets and Rail System (24" o.c.) Supporting Metal Cladding – Concrete Parapet and Roof Intersection

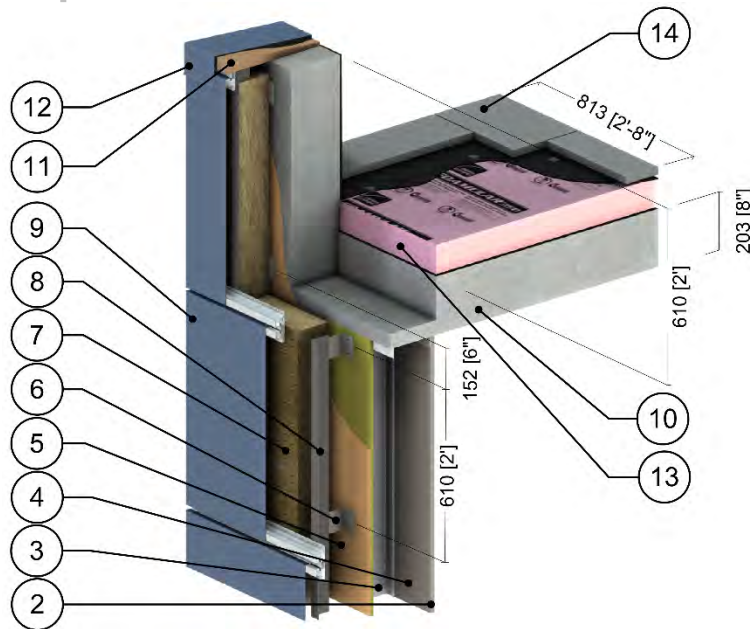

ID	Component	Thickness Inches (mm)	Conductivity Btu-in / ft ² -hr-°F (W/m K)	Nominal Resistance hr-ft ² -°F/Btu (m ² K/W)	Density lb/ft ³ (kg/m ³)	Specific Heat Btu/lb-°F (J/kg K)
1	Interior Film ¹	-	-	R-0.6 to R-0.7 (0.11 RSI to 0.12 RSI)	-	-
2	Gypsum Board	1/2" (13)	1.1 (0.16)	R-0.5 (0.08 RSI)	50 (800)	0.26 (1090)
3	6" x 1 5/8" Steel Studs with Tracks	18 Gauge	430 (62)	-	489 (7830)	0.12 (500)
4	Air in Stud Cavity	6" (152)	-	R-0.9 (0.16 RSI)	0.075 (1.2)	0.24 (1000)
5	Exterior Sheathing	5/8" (16)	1.1 (0.16)	R-0.6 (0.10 RSI)	50 (800)	0.26 (1090)
6	Thermally Isolated Aluminum Bracket	varies	-	-	-	-
7	Thermafiber RainBarrier 45 Mineral Wool Semi Rigid Insulation	varies	0.24 (0.034)	R-8.4 to R-21.0 (1.48 to 3.70 RSI)	4.5 (72)	0.20 (850)
8	Vertical Aluminum L-girt	0.09" (2.2)	1110 (160)	-	171 (2739)	0.22 (900)
9	Cladding with 1/2" (13mm) vented airspace incorporated into exterior heat transfer coefficient					
10	Concrete Slab	8" (203)	12.5 (1.8)	-	140 (2250)	0.20 (850)
11	Wood Blocking	5/8" (16)	0.69 (0.10)	R-1.0 (0.18 RSI)	31 (500)	0.45 (1880)
12	Cap Flashing	18 Gauge	430 (62)	-	489 (7830)	0.12 (500)
13	Foamular XPS Rigid Insulation	4" (102)	0.20 (0.029)	R-20 (3.52 RSI)	1.8 (28)	0.29 (1220)
14	Flashing & roof finish material are incorporated into exterior heat transfer coefficient					
15	Exterior Film ¹	-	-	R-0.2 to R-0.7 (0.03 RSI to 0.12 RSI)	-	-

¹ Value selected from table 1, p. 26.1 of 2009 ASHRAE Handbook – Fundamentals depending on surface orientation

Detail 5.5.13

Exterior and Interior Insulated 6" x 1 5/8" Steel Stud (16" o.c.) Wall Assembly with Thermally Isolated Vertical Brackets and Rail System (24" o.c.) Supporting Metal Cladding and Owens Corning R-20 Batt in Stud Cavity – Concrete Parapet and Roof Intersection

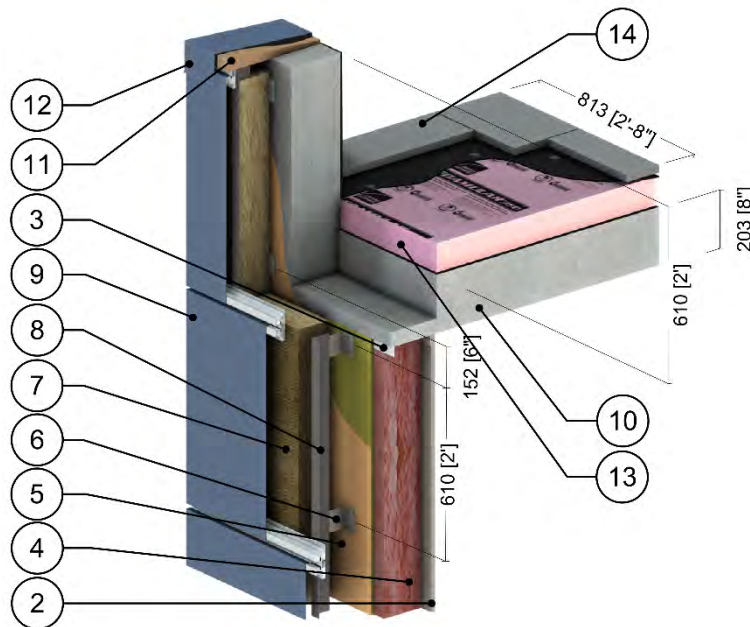

ID	Component	Thickness Inches (mm)	Conductivity Btu-in / ft ² -hr-°F (W/m K)	Nominal Resistance hr-ft ² -°F/Btu (m ² K/W)	Density lb/ft ³ (kg/m ³)	Specific Heat Btu/lb-°F (J/kg K)
1	Interior Film ¹	-	-	R-0.6 to R-0.7 (0.11 RSI to 0.12 RSI)	-	-
2	Gypsum Board	1/2" (13)	1.1 (0.16)	R-0.5 (0.08 RSI)	50 (800)	0.26 (1090)
3	6" x 1 5/8" Steel Studs with Tracks	18 Gauge	430 (62)	-	489 (7830)	0.12 (500)
4	Ecotouch Pink Fiberglass Batt	6" (152)	0.30 (0.043)	R-20 (3.52 RSI)	0.55 (8.8)	0.17 (710)
5	Exterior Sheathing	5/8" (16)	1.1 (0.16)	R-0.6 (0.10 RSI)	50 (800)	0.26 (1090)
6	Thermally Isolated Aluminum Bracket	varies	-	-	-	-
7	Thermafiber RainBarrier 45 Mineral Wool Semi Rigid Insulation	varies	0.24 (0.034)	R-8.4 to R-21.0 (1.48 to 3.70 RSI)	4.5 (72)	0.20 (850)
8	Vertical Aluminum L-girt	0.09" (2.2)	1110 (160)	-	171 (2739)	0.22 (900)
9	Cladding with 1/2" (13mm) vented airspace incorporated into exterior heat transfer coefficient					
10	Concrete Slab	8" (203)	12.5 (1.8)	-	140 (2250)	0.20 (850)
11	Wood Blocking	5/8" (16)	0.69 (0.10)	R-1.0 (0.18 RSI)	31 (500)	0.45 (1880)
12	Cap Flashing	18 Gauge	430 (62)	-	489 (7830)	0.12 (500)
13	Foamular XPS Rigid Insulation	4" (102)	0.20 (0.029)	R-20 (3.52 RSI)	1.8 (28)	0.29 (1220)
14	Flashing & roof finish material are incorporated into exterior heat transfer coefficient					
15	Exterior Film ¹	-	-	R-0.2 to R-0.7 (0.03 RSI to 0.12 RSI)	-	-

¹ Value selected from table 1, p. 26.1 of 2009 ASHRAE Handbook – Fundamentals depending on surface orientation

Detail 5.5.14

Exterior and Interior Insulated 6" x 1 5/8" Steel Stud (16" o.c.) Wall Assembly with Thermally Isolated Vertical Brackets and Rail System (24" o.c.) Supporting Metal Cladding and Owens Corning R-22.5 Batt in Stud Cavity – Concrete Parapet and Roof Intersection

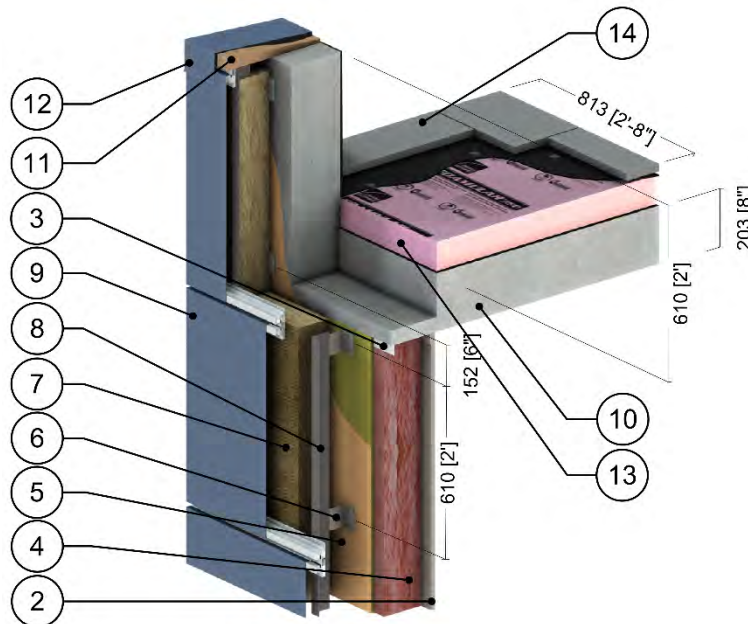

ID	Component	Thickness Inches (mm)	Conductivity Btu-in / ft ² ·hr·°F (W/m K)	Nominal Resistance hr·ft ² ·°F/Btu (m ² K/W)	Density lb/ft ³ (kg/m ³)	Specific Heat Btu/lb·°F (J/kg K)
1	Interior Film ¹	-	-	R-0.6 to R-0.7 (0.11 RSI to 0.12 RSI)	-	-
2	Gypsum Board	1/2" (13)	1.1 (0.16)	R-0.5 (0.08 RSI)	50 (800)	0.26 (1090)
3	6" x 1 5/8" Steel Studs with Tracks	18 Gauge	430 (62)	-	489 (7830)	0.12 (500)
4	Ecotouch Pink Fiberglass Batt	6" (152)	0.26 (0.038)	R-22.5 (3.96 RSI)	0.99 (15.9)	0.17 (710)
5	Exterior Sheathing	5/8" (16)	1.1 (0.16)	R-0.6 (0.10 RSI)	50 (800)	0.26 (1090)
6	Thermally Isolated Aluminum Bracket	varies	-	-	-	-
7	Thermafiber RainBarrier 45 Mineral Wool Semi Rigid Insulation	varies	0.24 (0.034)	R-8.4 to R-21.0 (1.48 to 3.70 RSI)	4.5 (72)	0.20 (850)
8	Vertical Aluminum L-girt	0.09" (2.2)	1110 (160)	-	171 (2739)	0.22 (900)
9	Cladding with 1/2" (13mm) vented airspace incorporated into exterior heat transfer coefficient					
10	Concrete Slab	8" (203)	12.5 (1.8)	-	140 (2250)	0.20 (850)
11	Wood Blocking	5/8" (16)	0.69 (0.10)	R-1.0 (0.18 RSI)	31 (500)	0.45 (1880)
12	Cap Flashing	18 Gauge	430 (62)	-	489 (7830)	0.12 (500)
13	Foamular XPS Rigid Insulation	4" (102)	0.20 (0.029)	R-20 (3.52 RSI)	1.8 (28)	0.29 (1220)
14	Flashing & roof finish material are incorporated into exterior heat transfer coefficient					
15	Exterior Film ¹	-	-	R-0.2 to R-0.7 (0.03 RSI to 0.12 RSI)	-	-

¹ Value selected from table 1, p. 26.1 of 2009 ASHRAE Handbook – Fundamentals depending on surface orientation

Detail 5.5.15

Exterior and Interior Insulated 6" x 1 5/8" Steel Stud (16" o.c.) Wall Assembly with Thermally Isolated Vertical Brackets and Rail System (24" o.c.) Supporting Metal Cladding and Owens Corning R-24 Batt in Stud Cavity – Concrete Parapet and Roof Intersection

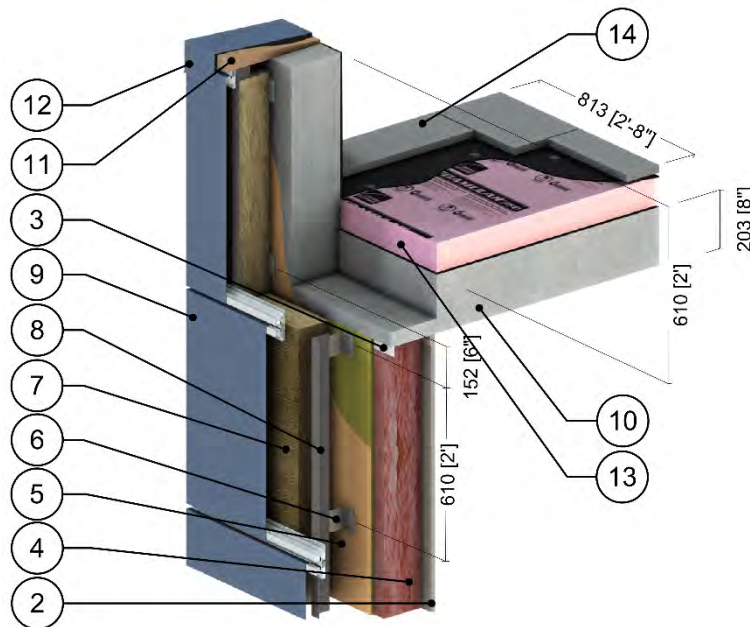

ID	Component	Thickness Inches (mm)	Conductivity Btu-in / ft ² -hr-°F (W/m K)	Nominal Resistance hr-ft ² -°F/Btu (m ² K/W)	Density lb/ft ³ (kg/m ³)	Specific Heat Btu/lb-°F (J/kg K)
1	Interior Film ¹	-	-	R-0.6 to R-0.7 (0.11 RSI to 0.12 RSI)	-	-
2	Gypsum Board	1/2" (13)	1.1 (0.16)	R-0.5 (0.08 RSI)	50 (800)	0.26 (1090)
3	6" x 1 5/8" Steel Studs with Tracks	18 Gauge	430 (62)	-	489 (7830)	0.12 (500)
4	Ecotouch Pink Fiberglass Batt	6" (152)	0.25 (0.036)	R-24 (4.23 RSI)	1.42 (22.7)	0.17 (710)
5	Exterior Sheathing	5/8" (16)	1.1 (0.16)	R-0.6 (0.10 RSI)	50 (800)	0.26 (1090)
6	Thermally Isolated Aluminum Bracket	varies	-	-	-	-
7	Thermafiber RainBarrier 45 Mineral Wool Semi Rigid Insulation	varies	0.24 (0.034)	R-8.4 to R-21.0 (1.48 to 3.70 RSI)	4.5 (72)	0.20 (850)
8	Vertical Aluminum L-girt	0.09" (2.2)	1110 (160)	-	171 (2739)	0.22 (900)
9	Cladding with 1/2" (13mm) vented airspace incorporated into exterior heat transfer coefficient					
10	Concrete Slab	8" (203)	12.5 (1.8)	-	140 (2250)	0.20 (850)
11	Wood Blocking	5/8" (16)	0.69 (0.10)	R-1.0 (0.18 RSI)	31 (500)	0.45 (1880)
12	Cap Flashing	18 Gauge	430 (62)	-	489 (7830)	0.12 (500)
13	Foamular XPS Rigid Insulation	4" (102)	0.20 (0.029)	R-20 (3.52 RSI)	1.8 (28)	0.29 (1220)
14	Flashing & roof finish material are incorporated into exterior heat transfer coefficient					
15	Exterior Film ¹	-	-	R-0.2 to R-0.7 (0.03 RSI to 0.12 RSI)	-	-

¹ Value selected from table 1, p. 26.1 of 2009 ASHRAE Handbook – Fundamentals depending on surface orientation

Detail 5.5.16

Owens Corning Exterior Insulated 6" x 1 5/8" Steel Stud (16" o.c.) Wall Assembly with Thermally Isolated Vertical Brackets and Rail System (24" o.c.) Supporting Metal Cladding – Concrete Roof Deck at Isokorb AXTI Thermal Broken Concrete Parapet

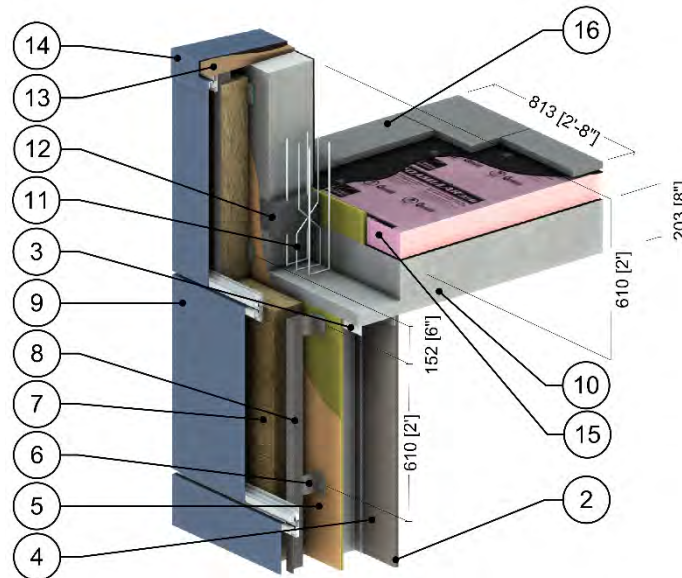

ID	Component	Thickness Inches (mm)	Conductivity Btu-in / ft ² ·hr·°F (W/m K)	Nominal Resistance hr·ft ² ·°F/Btu (m ² K/W)	Density lb/ft ³ (kg/m ³)	Specific Heat Btu/lb·°F (J/kg K)
1	Interior Film ¹	-	-	R-0.6 to R-0.7 (0.11 RSI to 0.12 RSI)	-	-
2	Gypsum Board	1/2" (13)	1.1 (0.16)	R-0.5 (0.08 RSI)	50 (800)	0.26 (1090)
3	6" x 1 5/8" Steel Studs with Tracks	18 Gauge	430 (62)	-	489 (7830)	0.12 (500)
4	Air in Stud Cavity	6" (152)	-	R-0.9 (0.16 RSI)	0.075 (1.2)	0.24 (1000)
5	Exterior Sheathing	5/8" (16)	1.1 (0.16)	R-0.6 (0.10 RSI)	50 (800)	0.26 (1090)
6	Thermally Isolated Aluminum Bracket	varies	-	-	-	-
7	Thermafiber RainBarrier 45 Mineral Wool Semi Rigid Insulation	varies	0.24 (0.034)	R-8.4 to R-21.0 (1.48 to 3.70 RSI)	4.5 (72)	0.20 (850)
8	Vertical Aluminum L-girt	0.09" (2.2)	1110 (160)	-	171 (2739)	0.22 (900)
9	Cladding with 1/2" (13mm) vented airspace incorporated into exterior heat transfer coefficient					
10	Concrete Slab	8" (203)	12.5 (1.8)	-	140 (2250)	0.20 (850)
11	Stainless Steel Rebar	-	118 (17)	-	500 (8000)	0.12 (500)
12	Polystyrene Rigid Foam Insulation	4 3/4" (120)	0.217 (0.031)	R-22.0 (3.87 RSI)	66 (1060)	0.35 (1500)
13	Wood Blocking	5/8" (16)	0.69 (0.10)	R-1.0 (0.18 RSI)	31 (500)	0.45 (1880)
14	Cap Flashing	18 Gauge	430 (62)	-	489 (7830)	0.12 (500)
15	Foamular XPS Rigid Insulation	4" (102)	0.20 (0.029)	R-20 (3.52 RSI)	1.8 (28)	0.29 (1220)
16	Flashing & roof finish material are incorporated into exterior heat transfer coefficient					
17	Exterior Film ¹	-	-	R-0.2 to R-0.7 (0.03 RSI to 0.12 RSI)	-	-

¹ Value selected from table 1, p. 26.1 of 2009 ASHRAE Handbook – Fundamentals depending on surface orientation

Detail 5.5.17

Exterior and Interior Insulated 6" x 1 5/8" Steel Stud (16" o.c.) Wall Assembly with Thermally Isolated Vertical Brackets and Rail System (24" o.c.) Supporting Metal Cladding and Owens Corning R-20 Batt in Stud Cavity – Concrete Roof Deck at Isokorb AXTI Thermal Broken Concrete Parapet

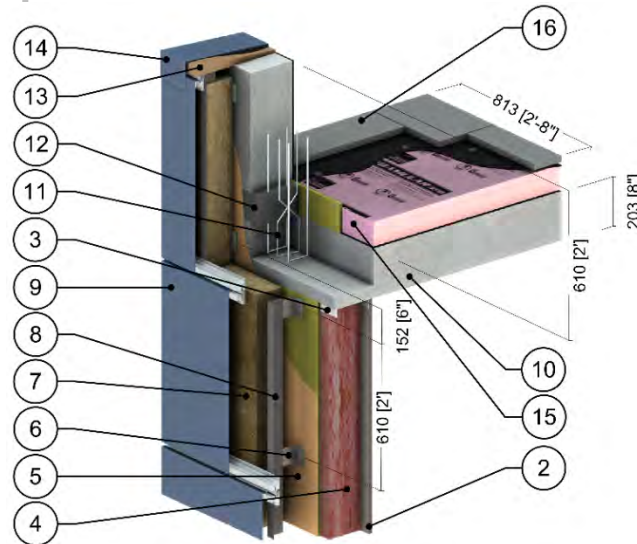

ID	Component	Thickness Inches (mm)	Conductivity Btu-in / ft ² ·hr·°F (W/m K)	Nominal Resistance hr·ft ² ·°F/Btu (m ² K/W)	Density lb/ft ³ (kg/m ³)	Specific Heat Btu/lb·°F (J/kg K)
1	Interior Film ¹	-	-	R-0.6 to R-0.7 (0.11 RSI to 0.12 RSI)	-	-
2	Gypsum Board	1/2" (13)	1.1 (0.16)	R-0.5 (0.08 RSI)	50 (800)	0.26 (1090)
3	6" x 1 5/8" Steel Studs with Tracks	18 Gauge	430 (62)	-	489 (7830)	0.12 (500)
4	Ecotouch Pink Fiberglass Batt	6" (152)	0.30 (0.043)	R-20 (3.52 RSI)	0.55 (8.8)	0.17 (710)
5	Exterior Sheathing	5/8" (16)	1.1 (0.16)	R-0.6 (0.10 RSI)	50 (800)	0.26 (1090)
6	Thermally Isolated Aluminum Bracket	varies	-	-	-	-
7	Thermafiber RainBarrier 45 Mineral Wool Semi Rigid Insulation	varies	0.24 (0.034)	R-8.4 to R-21.0 (1.48 to 3.70 RSI)	4.5 (72)	0.20 (850)
8	Vertical Aluminum L-girt	0.09" (2.2)	1110 (160)	-	171 (2739)	0.22 (900)
9	Cladding with 1/2" (13mm) vented airspace incorporated into exterior heat transfer coefficient					
10	Concrete Slab	8" (203)	12.5 (1.8)	-	140 (2250)	0.20 (850)
11	Stainless Steel Rebar	-	118 (17)	-	500 (8000)	0.12 (500)
12	Polystyrene Rigid Foam Insulation	4 3/4" (120)	0.217 (0.031)	R-22.0 (3.87 RSI)	66 (1060)	0.35 (1500)
13	Wood Blocking	5/8" (16)	0.69 (0.10)	R-1.0 (0.18 RSI)	31 (500)	0.45 (1880)
14	Cap Flashing	18 Gauge	430 (62)	-	489 (7830)	0.12 (500)
15	Foamular XPS Rigid Insulation	4" (102)	0.20 (0.029)	R-20 (3.52 RSI)	1.8 (28)	0.29 (1220)
16	Flashing & roof finish material are incorporated into exterior heat transfer coefficient					
17	Exterior Film ¹	-	-	R-0.2 to R-0.7 (0.03 RSI to 0.12 RSI)	-	-

¹ Value selected from table 1, p. 26.1 of 2009 ASHRAE Handbook – Fundamentals depending on surface orientation

Detail 5.5.18

Exterior and Interior Insulated 6" x 1 5/8" Steel Stud (16" o.c.) Wall Assembly with Thermally Isolated Vertical Brackets and Rail System (24" o.c.) Supporting Metal Cladding and Owens Corning R-22.5 Batt in Stud Cavity – Concrete Roof Deck at Isokorb AXTI Thermal Broken Concrete Parapet

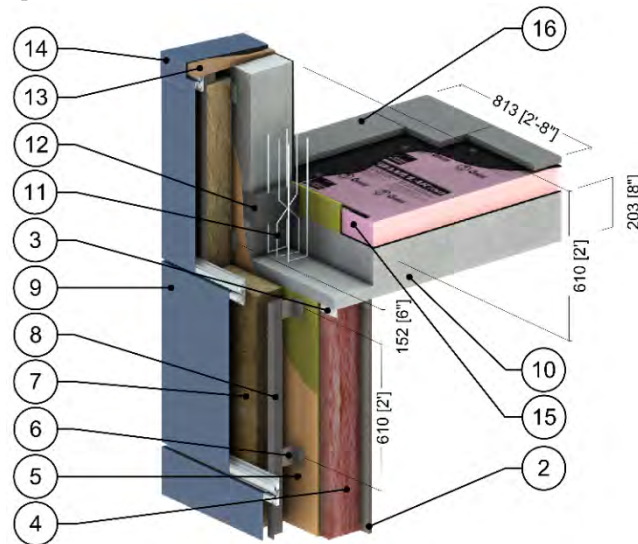

ID	Component	Thickness Inches (mm)	Conductivity Btu-in / ft ² ·hr·°F (W/m K)	Nominal Resistance hr·ft ² ·°F/Btu (m ² K/W)	Density lb/ft ³ (kg/m ³)	Specific Heat Btu/lb·°F (J/kg K)
1	Interior Film ¹	-	-	R-0.6 to R-0.7 (0.11 RSI to 0.12 RSI)	-	-
2	Gypsum Board	1/2" (13)	1.1 (0.16)	R-0.5 (0.08 RSI)	50 (800)	0.26 (1090)
3	6" x 1 5/8" Steel Studs with Tracks	18 Gauge	430 (62)	-	489 (7830)	0.12 (500)
4	Ecotouch Pink Fiberglass Batt	6" (152)	0.26 (0.038)	R-22.5 (3.96 RSI)	0.99 (15.9)	0.17 (710)
5	Exterior Sheathing	5/8" (16)	1.1 (0.16)	R-0.6 (0.10 RSI)	50 (800)	0.26 (1090)
6	Thermally Isolated Aluminum Bracket	varies	-	-	-	-
7	Thermafiber RainBarrier 45 Mineral Wool Semi Rigid Insulation	varies	0.24 (0.034)	R-8.4 to R-21.0 (1.48 to 3.70 RSI)	4.5 (72)	0.20 (850)
8	Vertical Aluminum L-girt	0.09" (2.2)	1110 (160)	-	171 (2739)	0.22 (900)
9	Cladding with 1/2" (13mm) vented airspace incorporated into exterior heat transfer coefficient					
10	Concrete Slab	8" (203)	12.5 (1.8)	-	140 (2250)	0.20 (850)
11	Stainless Steel Rebar	-	118 (17)	-	500 (8000)	0.12 (500)
12	Polystyrene Rigid Foam Insulation	4 3/4" (120)	0.217 (0.031)	R-22.0 (3.87 RSI)	66 (1060)	0.35 (1500)
13	Wood Blocking	5/8" (16)	0.69 (0.10)	R-1.0 (0.18 RSI)	31 (500)	0.45 (1880)
14	Cap Flashing	18 Gauge	430 (62)	-	489 (7830)	0.12 (500)
15	Foamular XPS Rigid Insulation	4" (102)	0.20 (0.029)	R-20 (3.52 RSI)	1.8 (28)	0.29 (1220)
16	Flashing & roof finish material are incorporated into exterior heat transfer coefficient					
17	Exterior Film ¹	-	-	R-0.2 to R-0.7 (0.03 RSI to 0.12 RSI)	-	-

¹ Value selected from table 1, p. 26.1 of 2009 ASHRAE Handbook – Fundamentals depending on surface orientation

Detail 5.5.19

Exterior and Interior Insulated 6" x 1 5/8" Steel Stud (16" o.c.) Wall Assembly with Thermally Isolated Vertical Brackets and Rail System (24" o.c.) Supporting Metal Cladding and Owens Corning R-24 Batt in Stud Cavity – Concrete Roof Deck at Isokorb AXTI Thermal Broken Concrete Parapet

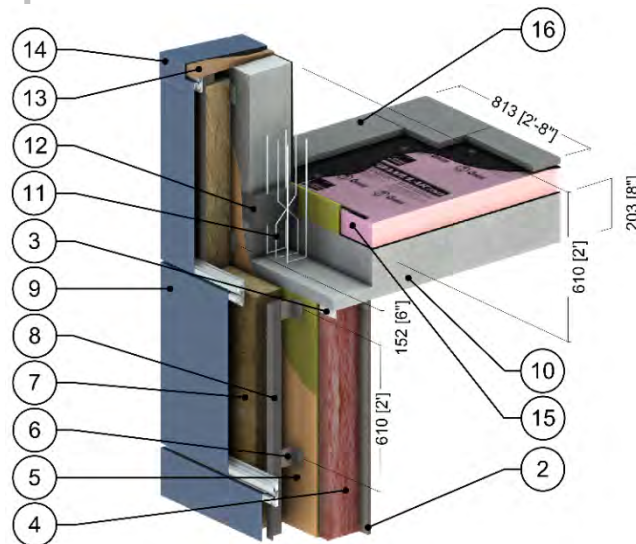

ID	Component	Thickness Inches (mm)	Conductivity Btu-in / ft ² ·hr·°F (W/m K)	Nominal Resistance hr·ft ² ·°F/Btu (m ² K/W)	Density lb/ft ³ (kg/m ³)	Specific Heat Btu/lb·°F (J/kg K)
1	Interior Film ¹	-	-	R-0.6 to R-0.7 (0.11 RSI to 0.12 RSI)	-	-
2	Gypsum Board	1/2" (13)	1.1 (0.16)	R-0.5 (0.08 RSI)	50 (800)	0.26 (1090)
3	6" x 1 5/8" Steel Studs with Tracks	18 Gauge	430 (62)	-	489 (7830)	0.12 (500)
4	Ecotouch Pink Fiberglass Batt	6" (152)	0.25 (0.036)	R-24 (4.23 RSI)	1.42 (22.7)	0.17 (710)
5	Exterior Sheathing	5/8" (16)	1.1 (0.16)	R-0.6 (0.10 RSI)	50 (800)	0.26 (1090)
6	Thermally Isolated Aluminum Bracket	varies	-	-	-	-
7	Thermafiber RainBarrier 45 Mineral Wool Semi Rigid Insulation	varies	0.24 (0.034)	R-8.4 to R-21.0 (1.48 to 3.70 RSI)	4.5 (72)	0.20 (850)
8	Vertical Aluminum L-girt	0.09" (2.2)	1110 (160)	-	171 (2739)	0.22 (900)
9	Cladding with 1/2" (13mm) vented airspace incorporated into exterior heat transfer coefficient					
10	Concrete Slab	8" (203)	12.5 (1.8)	-	140 (2250)	0.20 (850)
11	Stainless Steel Rebar	-	118 (17)	-	500 (8000)	0.12 (500)
12	Polystyrene Rigid Foam Insulation	4 3/4" (120)	0.217 (0.031)	R-22.0 (3.87 RSI)	66 (1060)	0.35 (1500)
13	Wood Blocking	5/8" (16)	0.69 (0.10)	R-1.0 (0.18 RSI)	31 (500)	0.45 (1880)
14	Cap Flashing	18 Gauge	430 (62)	-	489 (7830)	0.12 (500)
15	Foamular XPS Rigid Insulation	4" (102)	0.20 (0.029)	R-20 (3.52 RSI)	1.8 (28)	0.29 (1220)
16	Flashing & roof finish material are incorporated into exterior heat transfer coefficient					
17	Exterior Film ¹	-	-	R-0.2 to R-0.7 (0.03 RSI to 0.12 RSI)	-	-

¹ Value selected from table 1, p. 26.1 of 2009 ASHRAE Handbook – Fundamentals depending on surface orientation

Detail 5.5.20

Exterior Insulated 6" x 1 5/8" Steel Stud (16" o.c.) Wall Assembly with FRP and Thermally Broken Vertical Brackets and Rail System Supporting Metal Cladding – Concrete Roof Deck at Isokorb AXT Thermally Broken Concrete Parapet

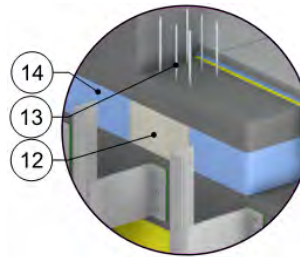
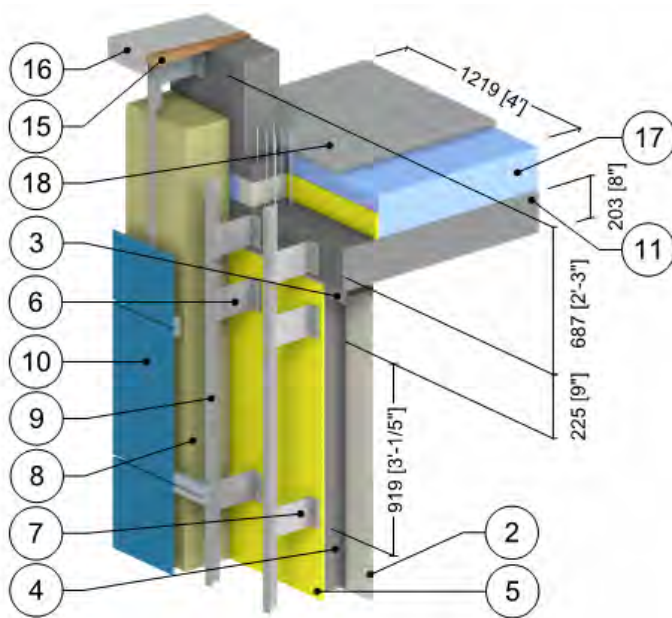

Scenario A - Sloped Roof

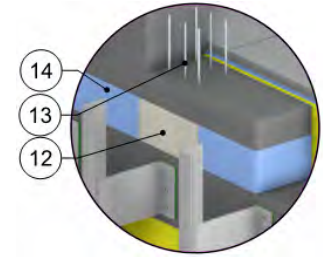

Scenario B - Concrete Topping

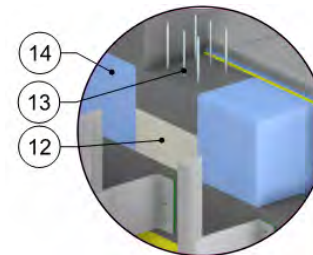

Scenario C - Insulation Between AXT Module at the Same Height as Roof Insulation

ID	Component	Thickness Inches (mm)	Conductivity Btu-in / ft ² ·hr·°F (W/m K)	Nominal Resistance hr·ft ² ·°F/Btu (m ² K/W)	Density lb/ft ³ (kg/m ³)	Specific Heat Btu/lb·°F (J/kg K)
1	Interior Film ¹	-	-	R-0.6 to R-0.7 (0.11 RSI to 0.12 RSI)	-	-
2	Gypsum Board	1/2" (13)	1.1 (0.16)	R-0.5 (0.08 RSI)	50 (800)	0.26 (1090)
3	6" x 1 5/8" Steel Studs with Top Track	18 Gauge	430 (62)	-	489 (7830)	0.12 (500)
4	Air in Stud Cavity	6" (152)	-	R-0.9 (0.16 RSI)	-	0.24 (1000)
5	Exterior Sheathing	1/2" (13)	1.1 (0.16)	R-0.5 (0.08 RSI)	50 (800)	0.26 (1090)
6	FRP Bracket	-	4.9 (0.70)	-	-	-
7	Aluminum Bracket	-	1110 (160)	-	171 (2739)	0.22 (900)
8	Exterior Mineral Wool Insulation	10" (254)	0.24 (0.034)	R-42 (7.40 RSI)	4.5 (72)	0.20 (850)
9	Vertical Aluminum L-Rail	0.09" (2.2)	1110 (160)	-	171 (2739)	0.22 (900)
10	Metal Cladding with 1/2" vented airspace incorporated into exterior heat transfer coefficient					
11	Concrete Slab and Parapet	8" (203)	12.5 (1.8)	-	140 (2250)	0.20 (850)
12	Isokorb AXT Module	-	-	-	-	-
13	Stainless Steel Rebar	-	118 (17)	-	48.1 (7700)	0.12 (500)
14	Polystyrene Foam Insulation	4.7" (120)	0.22 (0.031)	R-22 (3.87 RSI)	66 (1060)	0.35 (1500)
15	Wood Blocking	-	0.69 (0.10)	-	31 (500)	0.45 (1880)
16	Aluminum Cap Flashing	18 Gauge	1110 (160)	-	171 (2739)	0.12 (500)
17	Rigid Roof Insulation	8" (203)	0.20 (0.029)	R-40 (7.01 RSI)	1.8 (28)	0.29 (1220)
18	Flashing & roof finish material are incorporated into exterior heat transfer coefficient					
19	Exterior Film ¹	-	-	R-0.2 to R-0.7 (0.03 RSI to 0.12 RSI)	-	-

¹ Value selected from table 1, p. 26.1 of 2009 ASHRAE Handbook – Fundamentals depending on surface orientation

Detail 5.5.21

Exterior and Interior Insulated 6" x 1 5/8" Steel Stud (16" o.c.) Wall Assembly with FRP and Thermally Broken Vertical Brackets and Rail System Supporting Metal Cladding and R-19 Batt in Stud Cavity – Concrete Roof Deck at Isokorb AXT Thermally Broken Concrete Parapet

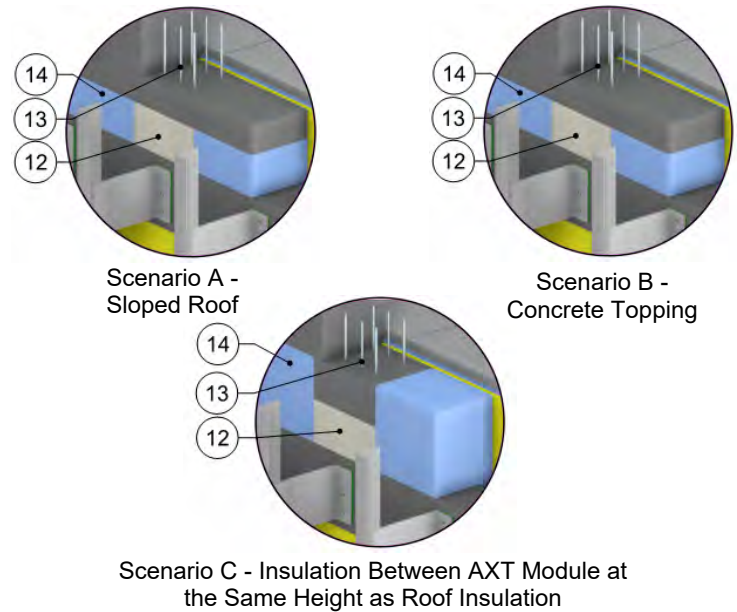
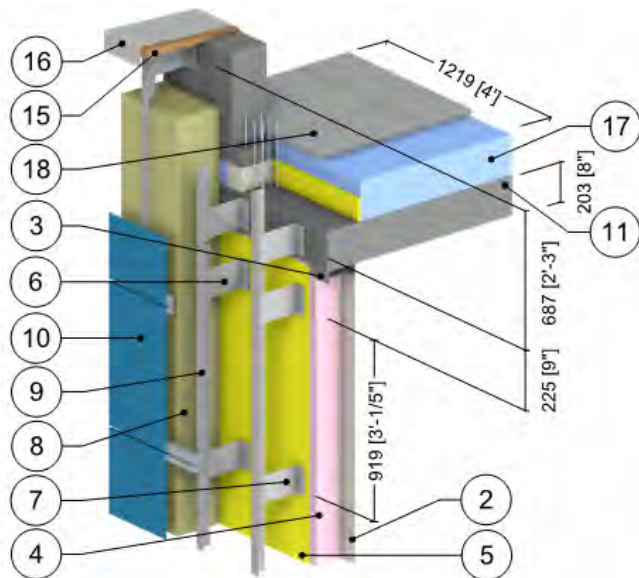

ID	Component	Thickness Inches (mm)	Conductivity Btu-in / ft ² ·hr·°F (W/m K)	Nominal Resistance hr·ft ² ·°F/Btu (m ² K/W)	Density lb/ft ³ (kg/m ³)	Specific Heat Btu/lb·°F (J/kg K)
1	Interior Film ¹	-	-	R-0.6 to R-0.7 (0.11 RSI to 0.12 RSI)	-	-
2	Gypsum Board	1/2" (13)	1.1 (0.16)	R-0.5 (0.08 RSI)	50 (800)	0.26 (1090)
3	6" x 1 5/8" Steel Studs with Top Track	18 Gauge	430 (62)	-	489 (7830)	0.12 (500)
4	Fiberglass Batt Insulation	6" (152)	0.32 (0.046)	R-19 (3.35 RSI)	0.9 (14)	0.17 (710)
5	Exterior Sheathing	1/2" (13)	1.1 (0.16)	R-0.5 (0.08 RSI)	50 (800)	0.26 (1090)
6	FRP Bracket	-	4.9 (0.70)	-	-	-
7	Aluminum Bracket	-	1110 (160)	-	171 (2739)	0.22 (900)
8	Semi Rigid Exterior Insulation	10" (254)	0.24 (0.034)	R-42 (7.40 RSI)	4.5 (72)	0.20 (850)
9	Vertical Aluminum L-Rail	0.09" (2.2)	1110 (160)	-	171 (2739)	0.22 (900)
10	Metal Cladding with 1/2" vented airspace incorporated into exterior heat transfer coefficient					
11	Concrete Slab and Parapet	8" (203)	12.5 (1.8)	-	140 (2250)	0.20 (850)
12	Isokorb AXT Module	-	-	-	-	-
13	Stainless Steel Rebar	-	118 (17)	-	48.1 (7700)	0.12 (500)
14	Polystyrene Foam Insulation	4.7" (120)	0.22 (0.031)	R-22 (3.87 RSI)	66 (1060)	0.35 (1500)
15	Wood Blocking	-	0.69 (0.10)	-	31 (500)	0.45 (1880)
16	Aluminum Cap Flashing	18 Gauge	1110 (160)	-	171 (2739)	0.12 (500)
17	Rigid Roof Insulation	8" (203)	0.20 (0.029)	R-40 (7.01 RSI)	1.8 (28)	0.29 (1220)
18	Flashing & roof finish material are incorporated into exterior heat transfer coefficient					
19	Exterior Film ¹	-	-	R-0.2 to R-0.7 (0.03 RSI to 0.12 RSI)	-	-

¹ Value selected from table 1, p. 26.1 of 2009 ASHRAE Handbook – Fundamentals depending on surface orientation

Detail 5.5.22

Exterior Insulated 6" x 1 5/8" Steel Stud (16" o.c.) Wall Assembly with Thermally Isolated Vertical Brackets and Rail System (24" o.c.) Supporting Metal Cladding – Concrete Parapet and Roof Intersection

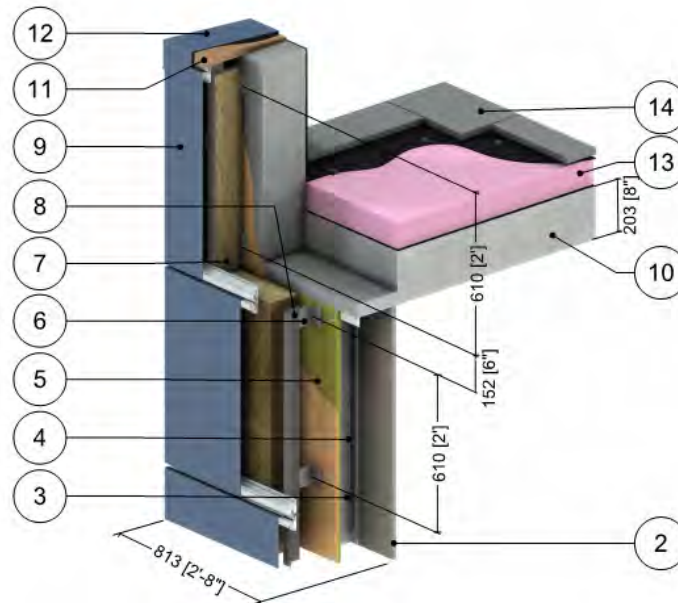

ID	Component	Thickness Inches (mm)	Conductivity Btu-in / ft ² ·hr·°F (W/m K)	Nominal Resistance hr·ft ² ·°F/Btu (m ² K/W)	Density lb/ft ³ (kg/m ³)	Specific Heat Btu/lb·°F (J/kg K)
1	Interior Film ¹	-	-	R-0.6 to R-0.7 (0.11 RSI to 0.12 RSI)	-	-
2	Gypsum Board	1/2" (13)	1.1 (0.16)	R-0.5 (0.08 RSI)	50 (800)	0.26 (1090)
3	6" x 1 5/8" Steel Studs with Tracks	18 Gauge	430 (62)	-	489 (7830)	0.12 (500)
4	Air in Stud Cavity	6" (152)	-	R-0.9 (0.16 RSI)	0.075 (1.2)	0.24 (1000)
5	Exterior Sheathing	5/8" (16)	1.1 (0.16)	R-0.6 (0.10 RSI)	50 (800)	0.26 (1090)
6	Thermally Isolated Aluminum Bracket	Varies	-	-	-	-
7	Exterior Mineral Wool Insulation	Varies	0.24 (0.034)	R-16.8 to R-29.4 (2.96 RSI to 5.18 RSI)	4 (64)	0.20 (850)
8	Vertical Aluminum L-girt – Aluminum 6005A alloy	0.09" (2.2)	1340 (193)	-	169 (2700)	0.22 (900)
9	Cladding with 1/2" (13mm) vented airspace incorporated into exterior heat transfer coefficient					
10	Concrete Slab	8" (203)	12.5 (1.8)	-	140 (2250)	0.20 (850)
11	Wood Blocking	5/8" (16)	0.69 (0.10)	R-1.0 (0.18 RSI)	31 (500)	0.45 (1880)
12	Cap Flashing	18 Gauge	430 (62)	-	489 (7830)	0.12 (500)
13	XPS Rigid Insulation	Varies	0.20 (0.029)	R-20 to R-40 (3.52 RSI to 7.04 RSI)	1.8 (28)	0.29 (1220)
14	Flashing & roof finish material are incorporated into exterior heat transfer coefficient					
15	Exterior Film ¹	-	-	R-0.2 to R-0.7 (0.03 RSI to 0.12 RSI)	-	-

¹ Value selected from table 1, p. 26.1 of 2009 ASHRAE Handbook – Fundamentals depending on surface orientation

Detail 5.5.23

Exterior and Interior Insulated 6" x 1 5/8" Steel Stud (16" o.c.) Wall Assembly with Thermally Isolated Vertical Brackets and Rail System (24" o.c.) Supporting Metal Cladding and R-20 Batt in Stud Cavity – Concrete Parapet and Roof Intersection

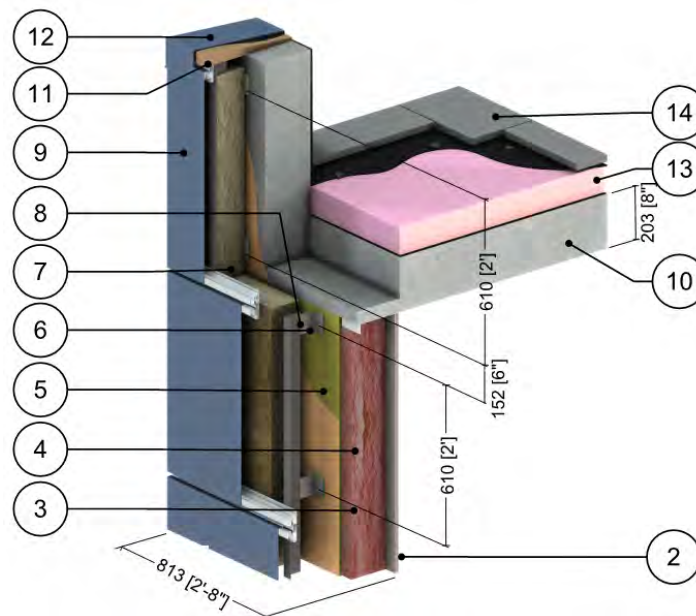

ID	Component	Thickness Inches (mm)	Conductivity Btu-in / ft ² -hr-°F (W/m K)	Nominal Resistance hr-ft ² -°F/Btu (m ² K/W)	Density lb/ft ³ (kg/m ³)	Specific Heat Btu/lb-°F (J/kg K)
1	Interior Film ¹	-	-	R-0.6 to R-0.7 (0.11 RSI to 0.12 RSI)	-	-
2	Gypsum Board	1/2" (13)	1.1 (0.16)	R-0.5 (0.08 RSI)	50 (800)	0.26 (1090)
3	6" x 1 5/8" Steel Studs with Tracks	18 Gauge	430 (62)	-	489 (7830)	0.12 (500)
4	Fiberglass Batt	6" (152)	0.30 (0.043)	R-20 (3.52 RSI)	0.9 (14)	0.17 (710)
5	Exterior Sheathing	5/8" (16)	1.1 (0.16)	R-0.6 (0.10 RSI)	50 (800)	0.26 (1090)
6	Thermally Isolated Aluminum Bracket	Varies	-	-	-	-
7	Exterior Mineral Wool Insulation	Varies	0.24 (0.034)	R-16.8 to R-29.4 (2.96 RSI to 5.18 RSI)	4 (64)	0.20 (850)
8	Vertical Aluminum L-girt – Aluminum 6005A alloy	0.09" (2.2)	1340 (193)	-	169 (2700)	0.22 (900)
9	Cladding with 1/2" (13mm) vented airspace incorporated into exterior heat transfer coefficient					
10	Concrete Slab	8" (203)	12.5 (1.8)	-	140 (2250)	0.20 (850)
11	Wood Blocking	5/8" (16)	0.69 (0.10)	R-1.0 (0.18 RSI)	31 (500)	0.45 (1880)
12	Cap Flashing	18 Gauge	430 (62)	-	489 (7830)	0.12 (500)
13	XPS Rigid Insulation	Varies	0.20 (0.029)	R-20 to R-40 (3.52 RSI to 7.04 RSI)	1.8 (28)	0.29 (1220)
14	Flashing & roof finish material are incorporated into exterior heat transfer coefficient					
15	Exterior Film ¹	-	-	R-0.2 to R-0.7 (0.03 RSI to 0.12 RSI)	-	-

¹ Value selected from table 1, p. 26.1 of 2009 ASHRAE Handbook – Fundamentals depending on surface orientation

Detail 5.5.24

Exterior Insulated 6" x 1 5/8" Steel Stud (16" o.c.) Wall Assembly with Thermally Isolated Vertical Brackets and Rail System (24" o.c.) Supporting Metal Cladding – Concrete Roof Deck at Isokorb AXTI Thermal Broken Concrete Parapet

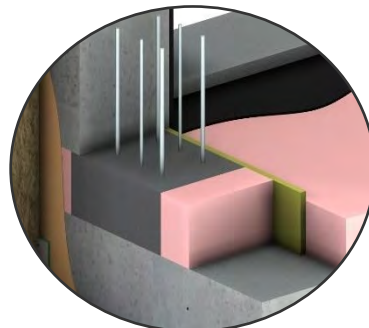
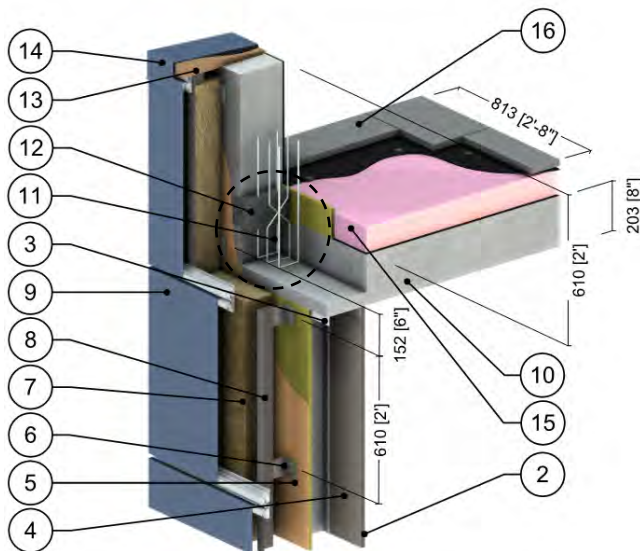

Roof Intersection with R-20 Roof Insulation

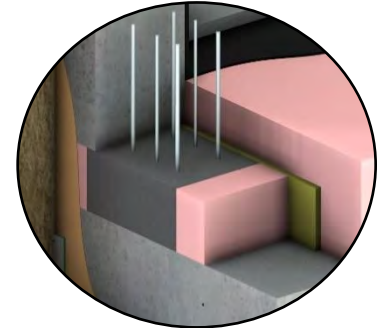

Roof Intersection with R-40 Roof Insulation

ID	Component	Thickness Inches (mm)	Conductivity Btu-in / ft ² ·hr·°F (W/m K)	Nominal Resistance hr·ft ² ·°F/Btu (m ² K/W)	Density lb/ft ³ (kg/m ³)	Specific Heat Btu/lb·°F (J/kg K)
1	Interior Film ¹	-	-	R-0.6 to R-0.7 (0.11 RSI to 0.12 RSI)	-	-
2	Gypsum Board	1/2" (13)	1.1 (0.16)	R-0.5 (0.08 RSI)	50 (800)	0.26 (1090)
3	6" x 1 5/8" Steel Studs with Tracks	18 Gauge	430 (62)	-	489 (7830)	0.12 (500)
4	Air in Stud Cavity	6" (152)	-	R-0.9 (0.16 RSI)	0.075 (1.2)	0.24 (1000)
5	Exterior Sheathing	5/8" (16)	1.1 (0.16)	R-0.6 (0.10 RSI)	50 (800)	0.26 (1090)
6	Thermally Isolated Aluminum Bracket	Varies	-	-	-	-
7	Exterior Mineral Wool Insulation	Varies	0.24 (0.034)	R-16.8 to R-29.4 (2.96 RSI to 5.18 RSI)	4 (64)	0.20 (850)
8	Vertical Aluminum L-girt – Aluminum 6005A alloy	0.09" (2.2)	1340 (193)	-	169 (2700)	0.22 (900)
9	Cladding with 1/2" (13mm) vented airspace incorporated into exterior heat transfer coefficient					
10	Concrete Slab	8" (203)	12.5 (1.8)	-	140 (2250)	0.20 (850)
11	Stainless Steel Rebar	-	118 (17)	-	500 (8000)	0.12 (500)
12	Polystyrene Rigid Foam Insulation	4 3/4" (120)	0.217 (0.031)	R-22.0 (3.87 RSI)	66 (1060)	0.35 (1500)
13	Wood Blocking	5/8" (16)	0.69 (0.10)	R-1.0 (0.18 RSI)	31 (500)	0.45 (1880)
14	Cap Flashing	18 Gauge	430 (62)	-	489 (7830)	0.12 (500)
15	XPS Rigid Insulation	Varies	0.20 (0.029)	R-20 to R-40 (3.52 RSI to 7.04 RSI)	1.8 (28)	0.29 (1220)
16	Flashing & roof finish material are incorporated into exterior heat transfer coefficient					
17	Exterior Film ¹	-	-	R-0.2 to R-0.7 (0.03 RSI to 0.12 RSI)	-	-

¹ Value selected from table 1, p. 26.1 of 2009 ASHRAE Handbook – Fundamentals depending on surface orientation



Detail 5.5.25

Exterior and Interior Insulated 6" x 1 5/8" Steel Stud (16" o.c.) Wall Assembly with Thermally Isolated Vertical Brackets and Rail System (24" o.c.) Supporting Metal Cladding and R-20 Batt in Stud Cavity – Concrete Roof Deck at Isokorb AXTI Thermal Broken Concrete Parapet

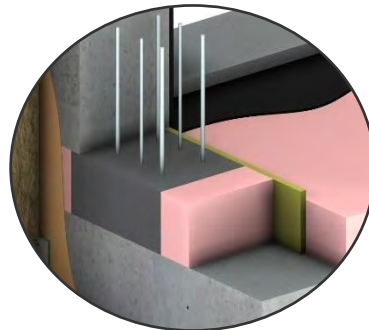
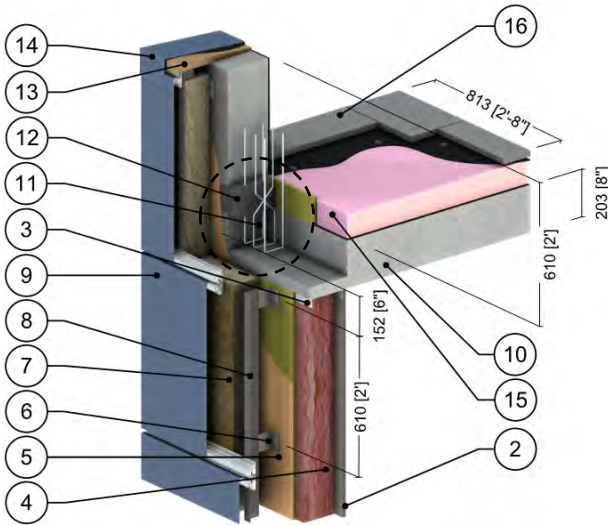

Roof Intersection with R-20 Roof Insulation

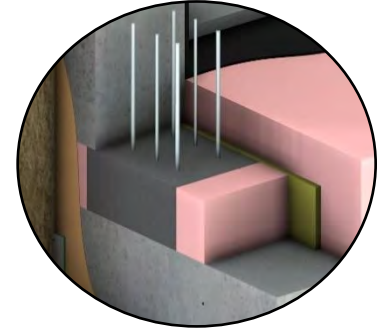

Roof Intersection with R-40 Roof Insulation

ID	Component	Thickness Inches (mm)	Conductivity Btu-in / ft ² ·hr·°F (W/m K)	Nominal Resistance hr·ft ² ·°F/Btu (m ² K/W)	Density lb/ft ³ (kg/m ³)	Specific Heat Btu/lb·°F (J/kg K)
1	Interior Film ¹	-	-	R-0.6 to R-0.7 (0.11 RSI to 0.12 RSI)	-	-
2	Gypsum Board	1/2" (13)	1.1 (0.16)	R-0.5 (0.08 RSI)	50 (800)	0.26 (1090)
3	6" x 1 5/8" Steel Studs with Tracks	18 Gauge	430 (62)	-	489 (7830)	0.12 (500)
4	Fiberglass Batt	6" (152)	0.30 (0.043)	R-20 (3.52 RSI)	0.9 (14)	0.17 (710)
5	Exterior Sheathing	5/8" (16)	1.1 (0.16)	R-0.6 (0.10 RSI)	50 (800)	0.26 (1090)
6	Thermally Isolated Aluminum Bracket	Varies	-	-	-	-
7	Exterior Mineral Wool Insulation	Varies	0.24 (0.034)	R-16.8 to R-29.4 (2.96 RSI to 5.18 RSI)	4 (64)	0.20 (850)
8	Vertical Aluminum L-girt – Aluminum 6005A alloy	0.09" (2.2)	1340 (193)	-	169 (2700)	0.22 (900)
9	Cladding with 1/2" (13mm) vented airspace incorporated into exterior heat transfer coefficient					
10	Concrete Slab	8" (203)	12.5 (1.8)	-	140 (2250)	0.20 (850)
11	Stainless Steel Rebar	-	118 (17)	-	500 (8000)	0.12 (500)
12	Polystyrene Rigid Foam Insulation	4 3/4" (120)	0.217 (0.031)	R-22.0 (3.87 RSI)	66 (1060)	0.35 (1500)
13	Wood Blocking	5/8" (16)	0.69 (0.10)	R-1.0 (0.18 RSI)	31 (500)	0.45 (1880)
14	Cap Flashing	18 Gauge	430 (62)	-	489 (7830)	0.12 (500)
15	XPS Rigid Insulation	Varies	0.20 (0.029)	R-20 to R-40 (3.52 RSI to 7.04 RSI)	1.8 (28)	0.29 (1220)
16	Flashing & roof finish material are incorporated into exterior heat transfer coefficient					
17	Exterior Film ¹	-	-	R-0.2 to R-0.7 (0.03 RSI to 0.12 RSI)	-	-

¹ Value selected from table 1, p. 26.1 of 2009 ASHRAE Handbook – Fundamentals depending on surface orientation



Detail 5.6.1

Exterior Insulated 3 5/8" x 1 5/8" Steel Stud (16" o.c.) Drained EIFS Wall Assembly – Corner Intersection

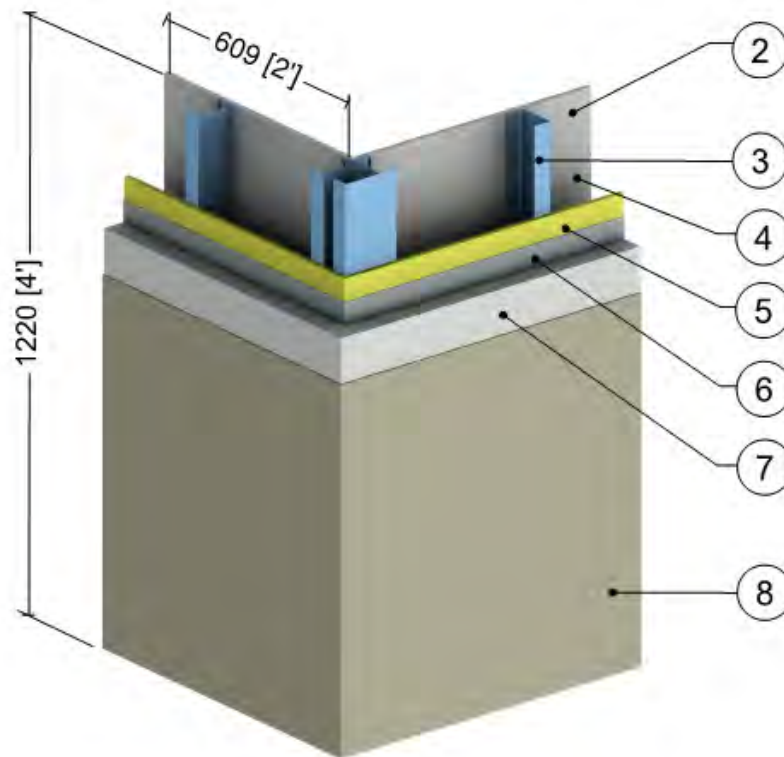

ID	Component	Thickness Inches (mm)	Conductivity Btu-in / ft ² -hr-°F (W/m K)	Nominal Resistance hr-ft ² -°F/Btu (m ² K/W)	Density lb/ft ³ (kg/m ³)	Specific Heat Btu/lb-°F (J/kg K)
1	Interior Films ¹	-	-	R-0.6 (0.11 RSI)	-	-
2	Gypsum Board	1/2" (13)	1.1 (0.16)	R-0.5 (0.08 RSI)	50 (800)	0.26 (1090)
3	3 5/8" x 1 5/8" Steel Studs (16"o.c.)	18 Gauge	430 (62)	-	489 (7830)	0.12 (500)
4	Air in Stud Cavity	3 5/8" (92)	-	R-0.9 (0.16 RSI)	0.075 (1.2)	0.24 (1000)
5	Exterior Sheathing	1/2" (13)	1.1 (0.16)	R-0.5 (0.08 RSI)	50 (800)	0.26 (1090)
6	Weather Resistive Barrier with Adhesive	-	-	-	-	-
7	Insulation Board	Varies	0.27 (0.039)	R-7.5 to R-15 (1.32 RSI to 2.64 RSI)	1 (16)	0.35 (1470)
8	Lamina	1/8" (4)	6 (0.9)	R-0.04 (0.01 RSI)	120 (1922)	0.20 (850)
9	Exterior Film ¹	-	-	R-0.2 (0.03 RSI)	-	-

¹ Value selected from table 1, p. 26.1 of 2009 ASHRAE Handbook – Fundamentals depending on surface orientation

Detail 5.6.2

Exterior and Interior Insulated 3 5/8" x 1 5/8" Steel Stud (16" o.c.) Drained EIFS Wall Assembly with R-12 Batt Insulation in Stud Cavity – Corner Intersection

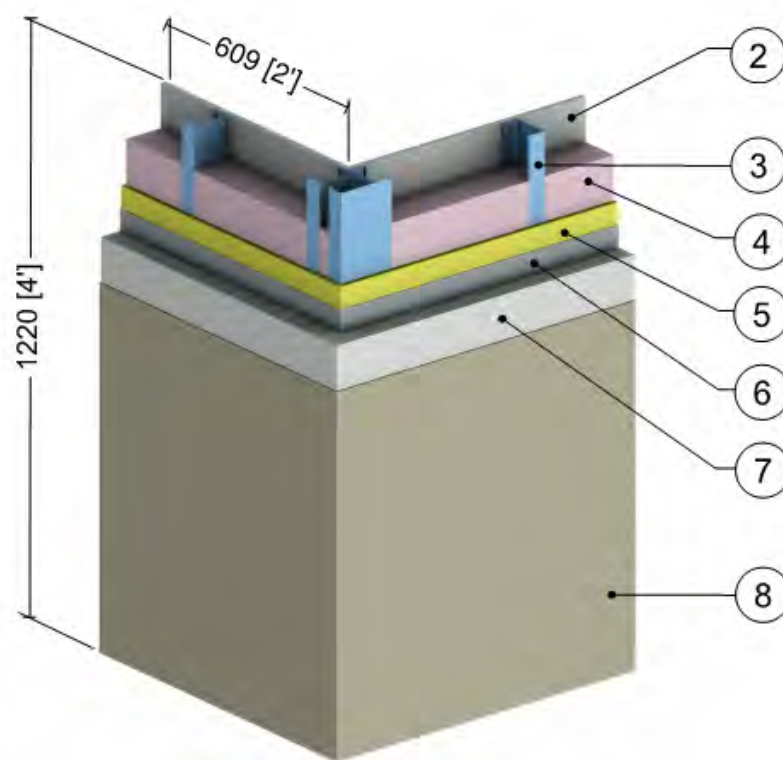

ID	Component	Thickness Inches (mm)	Conductivity Btu·in / ft ² ·hr·°F (W/m K)	Nominal Resistance hr·ft ² ·°F/Btu (m ² K/W)	Density lb/ft ³ (kg/m ³)	Specific Heat Btu/lb·°F (J/kg K)
1	Interior Films ¹	-	-	R-0.6 (0.11 RSI)	-	-
2	Gypsum Board	1/2" (13)	1.1 (0.16)	R-0.5 (0.08 RSI)	50 (800)	0.26 (1090)
3	3 5/8" x 1 5/8" Steel Studs (16"o.c.)	18 Gauge	430 (62)	-	489 (7830)	0.12 (500)
4	Fiberglass Batt Insulation	3 5/8" (92)	0.30 (0.043)	R-12 (2.1 RSI)	0.9 (1.1)	0.17 (710)
5	Exterior Sheathing	1/2" (13)	1.1 (0.16)	R-0.5 (0.08 RSI)	50 (800)	0.26 (1090)
6	Weather Resistive Barrier with Adhesive	-	-	-	-	-
7	Insulation Board	Varies	0.27 (0.039)	R-7.5 to R-15 (1.32 RSI to 2.64 RSI)	1 (16)	0.35 (1470)
8	Lamina	1/8" (4)	6 (0.9)	R-0.04 (0.01 RSI)	120 (1922)	0.20 (850)
9	Exterior Film ¹	-	-	R-0.2 (0.03 RSI)	-	-

¹ Value selected from table 1, p. 26.1 of 2009 ASHRAE Handbook – Fundamentals depending on surface orientation

Detail 5.6.3

Exterior Insulated 3 5/8" x 1 5/8" Steel Stud (16" o.c.) Wall Assembly with Horizontal Z-Girts (24" o.c.) Supporting Metal Cladding – Corner Intersection

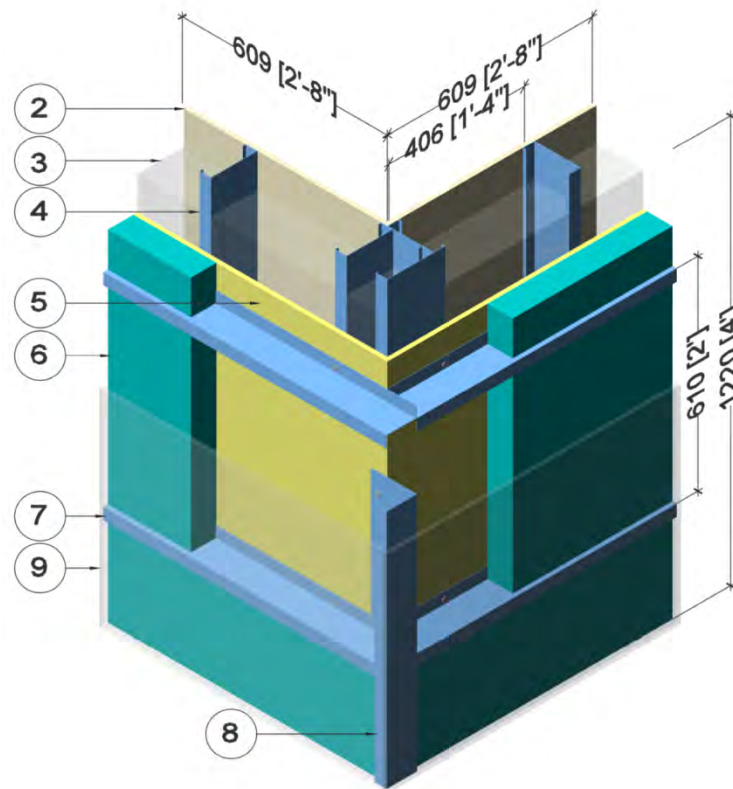

ID	Component	Thickness Inches (mm)	Conductivity Btu·in / ft ² ·hr·°F (W/m K)	Nominal Resistance hr·ft ² ·°F/Btu (m ² K/W)	Density lb/ft ³ (kg/m ³)	Specific Heat Btu/lb·°F (J/kg K)
1	Interior Film ¹	-	-	R-0.7 (0.12 RSI)	-	-
2	Gypsum Board	1/2" (13)	1.1 (0.16)	R-0.5 (0.08 RSI)	50 (800)	0.26 (1090)
3	Air in Stud Cavity	3 5/8" (92)	-	R-0.9 (0.16 RSI)	0.075 (1.2)	0.24 (1000)
4	3 5/8" x 1 5/8" Steel Studs	18 Gauge	430 (62)	-	489 (7830)	0.12 (500)
5	Exterior Sheathing	1/2" (13)	1.1 (0.16)	R-0.5 (0.08 RSI)	50 (800)	0.26 (1090)
6	Exterior Insulation	Varies	-	R-5 to R-25 (0.88 RSI to 4.4 RSI)	1.8 (28)	0.29 (1220)
7	Horizontal Z-Girts w/ 1 1/2" Flange	18 Gauge	430 (62)	-	489 (7830)	0.12 (500)
8	Corner Break Shape w/ 1 1/2" Flange	18 Gauge	430 (62)	-	489 (7830)	0.12 (500)
9	Metal cladding with 1/2" (13mm) vented air space is incorporated into exterior heat transfer coefficient					
10	Exterior Film ¹	-	-	R-0.7 (0.12 RSI)	-	-

¹ Value selected from table 1, p. 26.1 of 2009 ASHRAE Handbook – Fundamentals depending on surface orientation

Detail 5.6.4

Exterior Insulated 3 5/8" x 1 5/8" Steel Stud (16" o.c.) Wall Assembly with Horizontal Z-Girts (24" o.c.) Supporting Metal Cladding – Corner Intersection with Alternative Framing

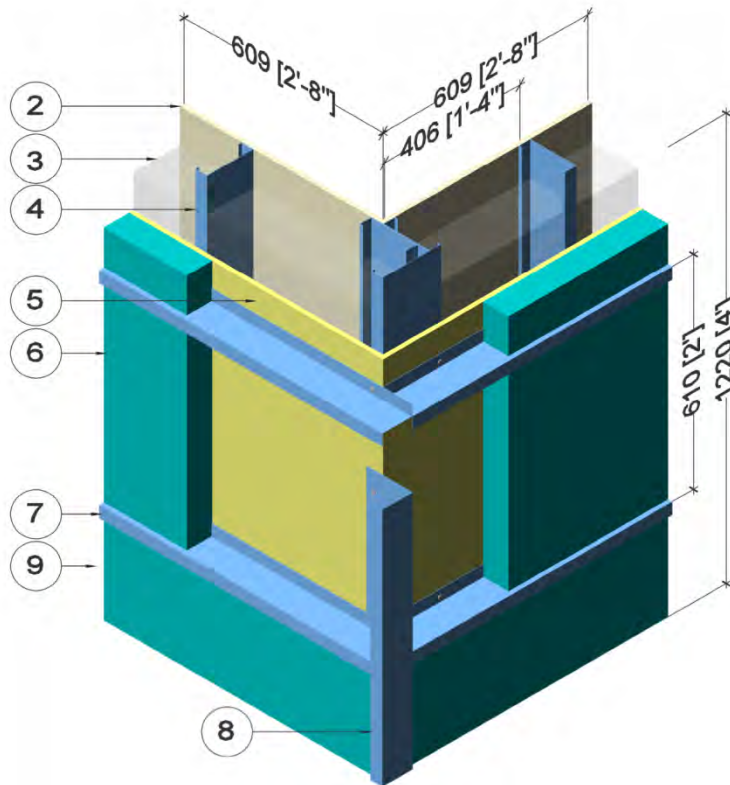

ID	Component	Thickness Inches (mm)	Conductivity Btu-in / ft ² ·hr·°F (W/m K)	Nominal Resistance hr·ft ² ·°F/Btu (m ² K/W)	Density lb/ft ³ (kg/m ³)	Specific Heat Btu/lb·°F (J/kg K)
1	Interior Film ¹	-	-	R-0.7 (0.12 RSI)	-	-
2	Gypsum Board	1/2" (13)	1.1 (0.16)	R-0.5 (0.08 RSI)	50 (800)	0.26 (1090)
3	Air in Stud Cavity	3 5/8" (92)	-	R-0.9 (0.16 RSI)	0.075 (1.2)	0.24 (1000)
4	3 5/8" x 1 5/8" Steel Studs	18 Gauge	430 (62)	-	489 (7830)	0.12 (500)
5	Exterior Sheathing	1/2" (13)	1.1 (0.16)	R-0.5 (0.08 RSI)	50 (800)	0.26 (1090)
6	Exterior Insulation	Varies	-	R-5 to R-25 (0.88 RSI to 4.4 RSI)	1.8 (28)	0.29 (1220)
7	Horizontal Z-girts w/ 1 1/2" Flange	18 Gauge	430 (62)	-	489 (7830)	0.12 (500)
8	Corner Break Shape w/ 1 1/2" Flange	18 Gauge	430 (62)	-	489 (7830)	0.12 (500)
9	Metal cladding with 1/2" (13mm) vented air space is incorporated into exterior heat transfer coefficient					
10	Exterior Film ¹	-	-	R-0.7 (0.12 RSI)	-	-

¹ Value selected from table 1, p. 26.1 of 2009 ASHRAE Handbook – Fundamentals depending on surface orientation

Detail 5.6.5

Exterior and Interior Insulated 3 5/8" x 1 5/8" Steel Stud (16" o.c.) Wall Assembly with Horizontal Z-girts (24" o.c.) Supporting Metal Cladding and R-12 Batt Insulation in Stud Cavity – Corner Intersection

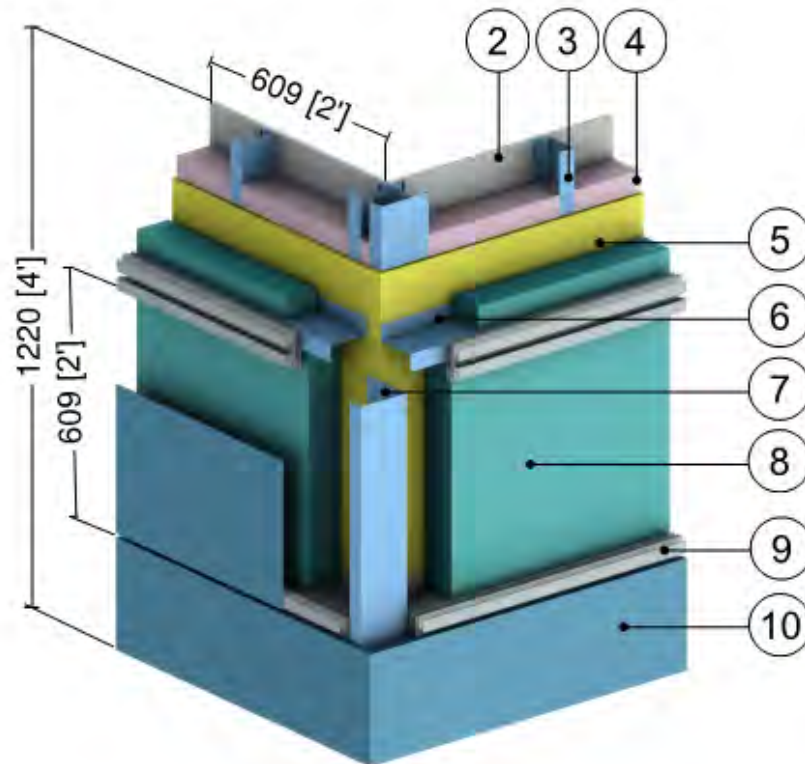

ID	Component	Thickness Inches (mm)	Conductivity Btu-in / ft ² -hr-°F (W/m K)	Nominal Resistance hr-ft ² -°F/Btu (m ² K/W)	Density lb/ft ³ (kg/m ³)	Specific Heat Btu/lb-°F (J/kg K)
1	Interior Films ¹	-	-	R-0.7 (0.12 RSI)	-	-
2	Gypsum Board	1/2" (13)	1.1 (0.16)	R-0.5 (0.08 RSI)	50 (800)	0.26 (1090)
3	3 5/8" x 1 5/8" Steel Studs	18 Gauge	430 (62)	-	489 (7830)	0.12 (500)
4	Fiberglass Batt Insulation	3 5/8" (92)	0.30 (0.043)	R-12 (2.1 RSI)	0.9 (14)	0.17 (710)
5	Exterior Sheathing	1/2" (13)	1.1 (0.16)	R-0.5 (0.08 RSI)	50 (800)	0.26 (1090)
6	Horizontal Z-Girt with 1 1/2" Flange	18 Gauge	430 (62)	-	489 (7830)	0.12 (500)
7	Corner Break Shape w/ 1 1/2" Flange	18 Gauge	430 (62)	-	489 (7830)	0.12 (500)
8	Exterior Insulation	Varies	-	R-10 to R-15 (1.76 RSI to 2.64 RSI)	1.8 (28)	0.29 (1220)
9	Panel Clip	14 Gauge	430 (62)	-	489 (7830)	0.12 (500)
10	Metal Cladding with 1/2" (13mm) vented airspace incorporated into exterior heat transfer coefficient					
11	Exterior Film ¹	-	-	R-0.7 (0.12 RSI)	-	-

¹ Value selected from table 1, p. 26.1 of 2009 ASHRAE Handbook – Fundamentals depending on surface orientation

Detail 5.6.6

Window Wall System – Transition to Exterior Insulated Steel Stud Wall Assembly with Horizontal Z-girts (24" o.c.) Supporting Metal Cladding & No Interior Stud Cavity Insulation

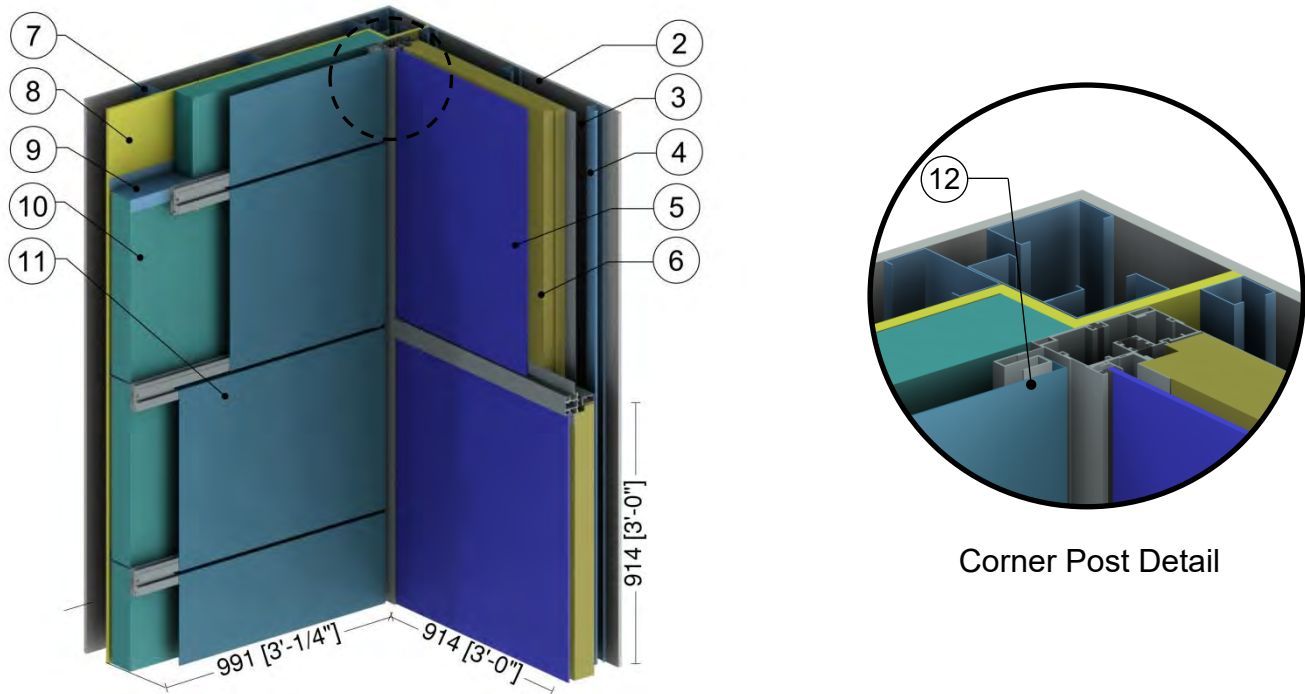

Corner Post Detail

ID	Component	Thickness Inches (mm)	Conductivity Btu-in / ft ² -hr-°F (W/m K)	Nominal Resistance hr-ft ² -°F/Btu (m ² K/W)	Density lb/ft ³ (kg/m ³)	Specific Heat Btu/lb-°F (J/kg K)
1	Interior Film ¹	-	-	R-0.7 (0.12 RSI)	-	-
2	Gypsum Board	1/2" (13)	1.1 (0.16)	R-0.5 (0.08 RSI)	50 (800)	0.26 (1090)
3	Air in Stud Cavity	3 5/8" (92)	-	R-0.9 (0.16 RSI)	0.075 (1.2)	0.24 (1000)
4	1 5/8" x 1 5/8" Steel Studs (16" o.c.)	18 Gauge	430 (62)	-	489 (7830)	0.12 (500)
5	Aluminum Window Wall Spandrel System with Insulated Backpan: thermally broken frame ²					
6	Backpan Insulation	-	-	R-16.8 (2.96 RSI)	4 (64)	0.20 (850)
7	3 5/8" x 1 5/8" Steel Studs (16" o.c.)	18 Gauge	430 (62)	-	489 (7830)	0.12 (500)
8	Exterior Sheathing	1/2" (13)	1.1 (0.16)	R-0.5 (0.08 RSI)	50 (800)	0.26 (1090)
9	Horizontal Z-girts (24" o.c.)	18 Gauge	430 (62)	-	489 (7830)	0.12 (500)
10	Exterior Insulation	Varies	-	R-15 to R-25 (2.64 RSI) to 4.40 RSI)	1.8 (28)	0.29 (1220)
11	Metal Cladding with 1/2" vented airspace incorporated into exterior heat transfer coefficient					
12	Aluminum Flashing	14 Gauge	1109 (16)	-	171 (2739)	0.21 (900)
13	Exterior Film ¹	-	-	R-0.2 (0.03 RSI)	-	-

¹ Value selected from table 1, p. 26.1 of 2009 ASHRAE Handbook – Fundamentals depending on surface orientation

² The thermal conductivity of air spaces within framing was found using ISO 100077-2

Detail 5.6.7

Window Wall System – Transition to Exterior Insulated Steel Stud Wall Assembly with Horizontal Z-girts (24" o.c.) Supporting Metal Cladding & Interior Sprayfoam and Fibreglass Batt Insulation

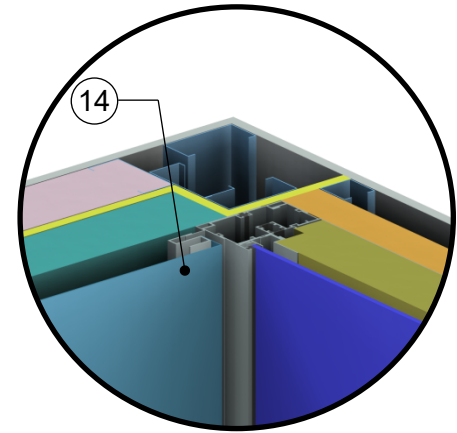
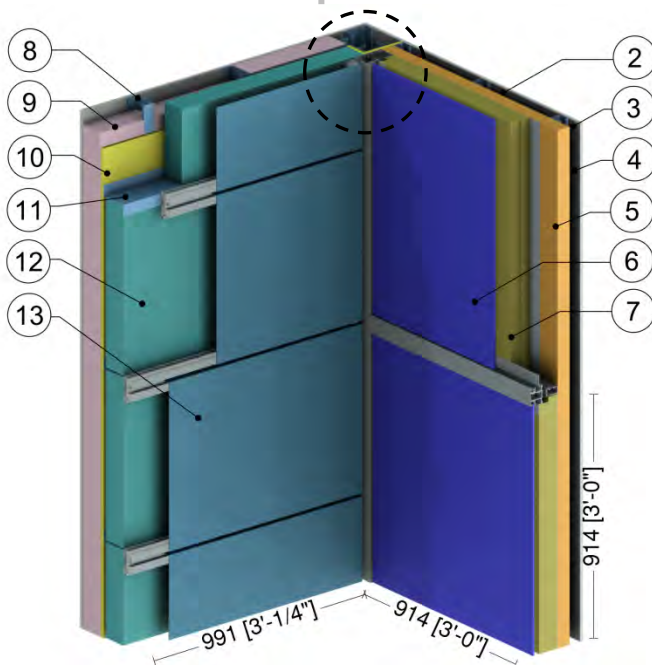

Corner Post Detail

ID	Component	Thickness Inches (mm)	Conductivity Btu-in / ft ² ·hr·°F (W/m K)	Nominal Resistance hr·ft ² ·°F/Btu (m ² K/W)	Density lb/ft ³ (kg/m ³)	Specific Heat Btu/lb·°F (J/kg K)
1	Interior Film ¹	-	-	R-0.7 (0.12 RSI)	-	-
2	Gypsum Board	1/2" (13)	1.1 (0.16)	R-0.5 (0.08 RSI)	50 (800)	0.26 (1090)
3	Air in Stud Cavity	1 5/8" (41)	-	R-0.9 (0.16 RSI)	0.075 (1.2)	0.24 (1000)
4	1 5/8" x 1 5/8" Steel Studs (16" o.c.)	18 Gauge	430 (62)	-	489 (7830)	0.12 (500)
5	Continuous Sprayfoam Insulation	2" (51)	0.17 (0.024)	R-12 (2.11 RSI)	2.8 (39)	0.35 (1470)
6	Aluminum Window Wall Spandrel System with Insulated Backpan: thermally broken frame ²					
7	Backpan Insulation	Varies	-	R-8.4 to R-16.8 (1.48 RSI to 2.96 RSI)	4 (64)	0.20 (850)
8	3 5/8" x 1 5/8" Steel Studs (16" o.c.)	18 Gauge	430 (62)	-	489 (7830)	0.12 (500)
9	Fiberglass Batt Insulation	3 5/8" (92)	0.30 (0.043)	R-12 (2.1 RSI)	0.9 (14)	0.17 (710)
10	Exterior Sheathing	1/2" (13)	1.1 (0.16)	R-0.5 (0.08 RSI)	50 (800)	0.26 (1090)
11	Horizontal Z-girts (24" o.c.)	18 Gauge	430 (62)	-	489 (7830)	0.12 (500)
12	Exterior Insulation	Varies	-	R-15 to R-25 (2.64 RSI to 4.40 RSI)	1.8 (28)	0.29 (1220)
13	Metal Cladding with 1/2" vented airspace incorporated into exterior heat transfer coefficient					
14	Aluminum Flashing	14 Gauge	1109 (160)	-	171 (2739)	0.21 (900)
15	Exterior Film ¹	-	-	R-0.2 (0.03 RSI)	-	-

¹ Value selected from table 1, p. 26.1 of 2009 ASHRAE Handbook – Fundamentals depending on surface orientation

² The thermal conductivity of air spaces within framing was found using ISO 100077-2

Detail 5.7.1

Exterior and Interior Insulated 3 5/8" x 1 5/8" Steel Stud (16" o.c.) Wall Assembly with Horizontal Z-Girts (24" o.c.) Supporting Metal Cladding and R-12 Batt Insulation in Stud Cavity – Structural Steel Column & Cantilever Beam Intersection (Canopy Support)

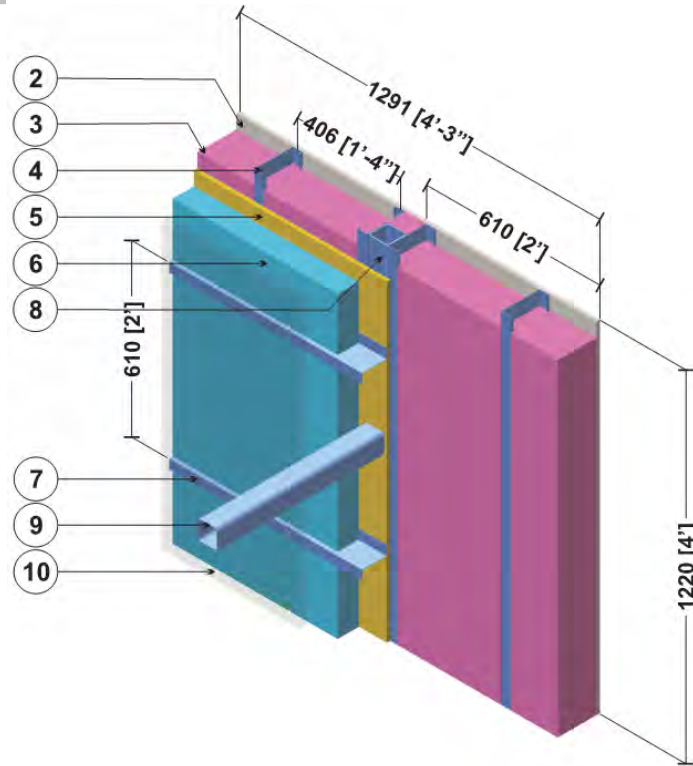

ID	Component	Thickness Inches (mm)	Conductivity Btu-in / ft ² ·hr·°F (W/m K)	Nominal Resistance hr·ft ² ·°F/Btu (m ² K/W)	Density lb/ft ³ (kg/m ³)	Specific Heat Btu/lb·°F (J/kg K)
1	Interior Film ¹	-	-	R-0.7 (0.12 RSI)	-	-
2	Gypsum Board	1/2" (13)	1.1 (0.16)	R-0.5 (0.08 RSI)	50 (800)	0.26 (1090)
3	Fiberglass Batt Insulation	3 5/8" (92)	0.30 (0.043)	R-12 (2.1 RSI)	0.9 (14)	0.17 (710)
4	3 5/8" x 1 5/8" Steel Studs	18 Gauge	430 (62)	-	489 (7830)	0.12 (500)
5	Exterior Sheathing	1/2" (13)	1.1 (0.16)	R-0.5 (0.08 RSI)	50 (800)	0.26 (1090)
6	Exterior Insulation	Varies	-	R-5 to R-25 (0.88 RSI to 4.4 RSI)	1.8 (28)	0.29 (1220)
7	Horizontal Z-girts w/ 1 1/2" Flange	18 Gauge	430 (62)	-	489 (7830)	0.12 (500)
8	Steel Post (HSS 76x76x3.2)	1/8" (3)	347 (50)	-	489 (7830)	0.12 (500)
9	Steel Beam (HSS 76x76x3.2)	1/8" (3)	347 (50)	-	489 (7830)	0.12 (500)
10	Metal cladding with 1/2" (13mm) vented air space is incorporated into exterior heat transfer coefficient					
11	Exterior Film ¹	-	-	R-0.2 to R-0.7 (0.03 RSI to 0.12 RSI)	-	-

¹ Value selected from table 1, p. 26.1 of 2009 ASHRAE Handbook – Fundamentals depending on surface orientation

Detail 5.7.2

Exterior and Interior Insulated 3 5/8" x 1 5/8" Steel Stud (16" o.c.) Wall Assembly with Horizontal Z-girts (24" o.c.) Supporting Metal Cladding and R-12 Batt Insulation in Stud Cavity – Structural Steel Floor Intersection with Uninterrupted Beam

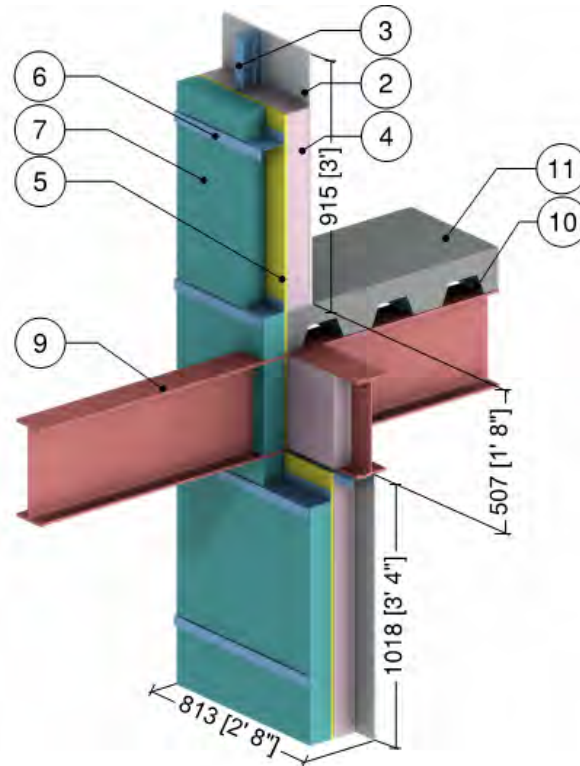

ID	Component	Thickness Inches (mm)	Conductivity Btu-in / ft ² ·hr·°F (W/m K)	Nominal Resistance hr·ft ² ·°F/Btu (m ² K/W)	Density lb/ft ³ (kg/m ³)	Specific Heat Btu/lb·°F (J/kg K)
1	Interior Film ¹	-	-	R-0.6 to R-0.9 (0.11 RSI to 0.16 RSI)	-	-
2	Gypsum Board	1/2" (13)	1.1 (0.16)	R-0.5 (0.08 RSI)	50 (800)	0.26 (1090)
3	3 5/8" x 1 5/8" Steel Studs with Top and Bottom Tracks	18 Gauge	430 (62)	-	489 (7830)	0.12 (500)
4	Fibreglass Batt Insulation	3 5/8" (92)	0.30 (0.043)	R-12.0 (2.11 RSI)	0.9 (14)	0.17 (710)
5	Exterior Sheathing	1/2" (13)	1.1 (0.16)	R-0.5 (0.08 RSI)	50 (800)	0.26 (1090)
6	Horizontal Z-girts with 1 1/2" Flange	18 Gauge	430 (62)	-	489 (7830)	0.12 (500)
7	Exterior Insulation	3" (76)	-	R-15 (2.64 RSI)	1.8 (28)	0.29 (1220)
8	Metal Cladding with 1/2" vented airspace incorporated into exterior heat transfer coefficient					
9	Steel Through Beam W14x26 (W360x39)	-	347 (50)	-	489 (7830)	0.12 (500)
10	Steel Deck	18 Gauge	430 (62)	-	489 (7830)	0.12 (500)
11	Concrete Topping	6" (152)	12.5 (1.8)	-	140 (2250)	0.20 (850)
12	Exterior Film ¹	-	-	R-0.7 (0.12 RSI)	-	-

¹ Value selected from table 1, p. 26.1 of 2009 ASHRAE Handbook – Fundamentals depending on surface orientation

Detail 5.7.3

Exterior and Interior Insulated 3 5/8" x 1 5/8" Steel Stud (16" o.c.) Wall Assembly with Horizontal Z-girts (24" o.c.) Supporting Metal Cladding and R-12 Batt Insulation in Stud Cavity – Structural Steel Floor Intersection with Isolator Pad

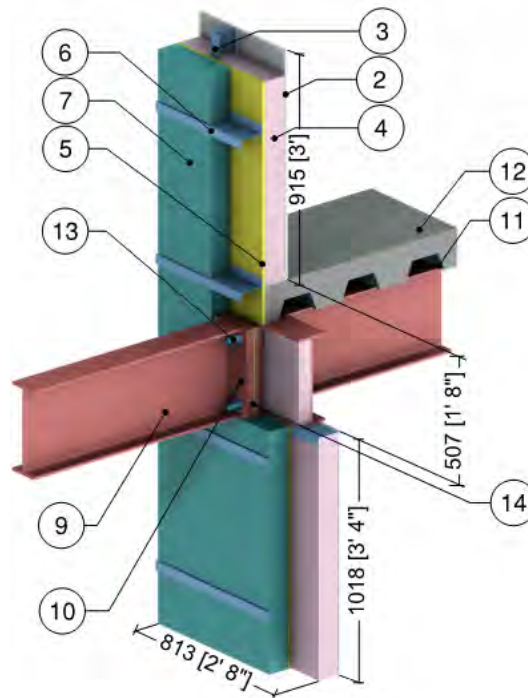

ID	Component	Thickness Inches (mm)	Conductivity Btu-in / ft ² -hr-°F (W/m K)	Nominal Resistance hr-ft ² -°F/Btu (m ² K/W)	Density lb/ft ³ (kg/m ³)	Specific Heat Btu/lb-°F (J/kg K)
1	Interior Film ¹	-	-	R-0.6 to R-0.9 (0.11 RSI to 0.16 RSI)	-	-
2	Gypsum Board	1/2" (13)	1.1 (0.16)	R-0.5 (0.08 RSI)	50 (800)	0.26 (1090)
3	3 5/8" x 1 5/8" Steel Studs with Top and Bottom Tracks	18 Gauge	430 (62)	-	489 (7830)	0.12 (500)
4	Fibreglass Batt Insulation	3 5/8" (92)	0.30 (0.043)	R-12.0 (2.10 RSI)	0.9 (14)	0.17 (710)
5	Exterior Sheathing	1/2" (13)	1.1 (0.16)	R-0.5 (0.08 RSI)	50 (800)	0.26 (1090)
6	Horizontal Z-girts with 1 1/2" Flange	18 Gauge	430 (62)	-	489 (7830)	0.12 (500)
7	Exterior Insulation	3" (76)	0.2 (0.029)	R-15.0 (2.64 RSI)	1.8 (28)	0.29 (1220)
8	Metal Cladding with 1/2" vented airspace incorporated into exterior heat transfer coefficient					
9	Steel Beam W14x26 (W360x39)	-	347 (50)	-	489 (7830)	0.12 (500)
10	Steel Bearing Plates	1 3/16" (30)	347 (50)	-	489 (7830)	0.12 (500)
11	Steel Deck	18 Gauge	430 (62)	-	489 (7830)	0.12 (500)
12	Concrete Topping	6" (152)	12.5 (1.8)	-	140 (2250)	0.20 (850)
13	Steel or Stainless Steel Bolts	-	347 to 118 (50 to 17)	-	500 (8000)	0.12 (500)
14	Polymer Thermal Isolator Pad	3/16" to 3/8" (5 to 10)	1.7 (0.25)	-	137 (2200)	0.31 (1300)
15	Exterior Film ¹	-	-	R-0.7 (0.12 RSI)	-	-

¹ Value selected from table 1, p. 26.1 of 2009 ASHRAE Handbook – Fundamentals depending on surface orientation

Detail 5.7.4

Exterior and Interior Insulated 3 5/8" x 1 5/8" Steel Stud (16" o.c.) Wall Assembly with Horizontal Z-girts (24" o.c.) Supporting Metal Cladding and R-12 Batt Insulation in Stud Cavity – Structural Steel Floor Intersection with Isokorb S22 Thermally Broken Beam

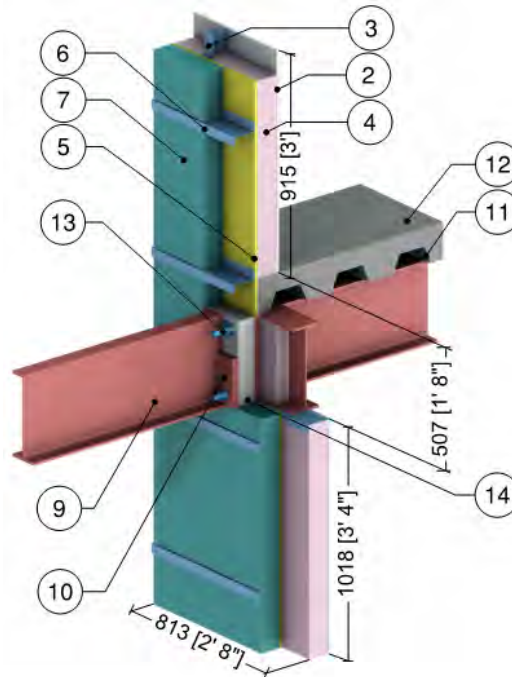

ID	Component	Thickness Inches (mm)	Conductivity Btu-in / ft ² ·hr·°F (W/m K)	Nominal Resistance hr·ft ² ·°F/Btu (m ² K/W)	Density lb/ft ³ (kg/m ³)	Specific Heat Btu/lb·°F (J/kg K)
1	Interior Film ¹	-	-	R-0.6 to R-0.9 (0.11 RSI to 0.16 RSI)	-	-
2	Gypsum Board	1/2" (13)	1.1 (0.16)	R-0.5 (0.08 RSI)	50 (800)	0.26 (1090)
3	3 5/8" x 1 5/8" Steel Studs with Top and Bottom Tracks	18 Gauge	430 (62)	-	489 (7830)	0.12 (500)
4	Fibreglass Batt Insulation	3 5/8" (92)	0.30 (0.043)	R-12.0 (2.11 RSI)	0.9 (14)	0.17 (710)
5	Exterior Sheathing	1/2" (13)	1.1 (0.16)	R-0.5 (0.08 RSI)	50 (800)	0.26 (1090)
6	Horizontal Z-girts with 1 1/2" Flange	18 Gauge	430 (62)	-	489 (7830)	0.12 (500)
7	Exterior Insulation	3" (76)	-	R-15 (2.64 RSI)	1.8 (28)	0.29 (1220)
8	Metal Cladding with 1/2" vented airspace incorporated into exterior heat transfer coefficient					
9	Steel Beam W14x26 (W360x39)	-	347 (50)	-	489 (7830)	0.12 (500)
10	Steel Bearing Plates	1 3/16" (30)	347 (50)	-	489 (7830)	0.12 (500)
11	Steel Deck	18 Gauge	430 (62)	-	489 (7830)	0.12 (500)
12	Concrete Topping	6" (152)	12.5 (1.8)	-	140 (2250)	0.20 (850)
Isokorb S22 Thermal Break						
13	Stainless Steel Bolts, Plates and HSS	-	118 (17)	-	500 (8000)	0.12 (500)
14	Polystyrene Hard Foam Insulation	3 1/8" (80)	0.217 (0.031)	R-14.5 (2.6 RSI)	66 (1060)	0.35 (1500)
15	Exterior Film ¹	-	-	R-0.7 (0.12 RSI)	-	-

¹ Value selected from table 1, p. 26.1 of 2009 ASHRAE Handbook – Fundamentals depending on surface orientation

Detail 5.7.5

Exterior Insulated 3 5/8" x 1 5/8" Steel Stud (16" o.c.) Wall Assembly with Intermittent Vertical Z-girts (16" o.c.) Supporting Metal Cladding – Concrete Floor to Steel Beam Connection

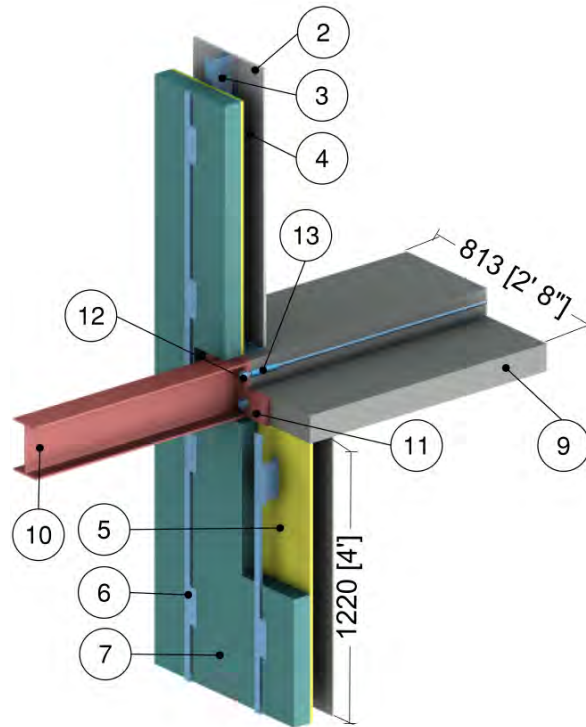

ID	Component	Thickness Inches (mm)	Conductivity Btu-in / ft ² -hr-°F (W/m K)	Nominal Resistance hr-ft ² -°F/Btu (m ² K/W)	Density lb/ft ³ (kg/m ³)	Specific Heat Btu/lb-°F (J/kg K)
1	Interior Film ¹	-	-	R-0.6 to R-0.9 (0.11 RSI to 0.16 RSI)	-	-
2	Gypsum Board	1/2" (13)	1.1 (0.16)	R-0.5 (0.08 RSI)	50 (800)	0.26 (1090)
3	3 5/8" x 1 5/8" Steel Studs with Top and Bottom Tracks	18 Gauge	430 (62)	-	489 (7830)	0.12 (500)
4	Air Cavity	3 5/8" (92)	-	R-0.9 (0.16 RSI)	0.075 (1.2)	0.24 (1000)
5	Exterior Sheathing	1/2" (13)	1.1 (0.16)	R-0.5 (0.08 RSI)	50 (800)	0.26 (1090)
6	Intermittent Vertical Z-Girts with 1 1/2" Flange	18 Gauge	430 (62)	-	489 (7830)	0.12 (500)
7	Exterior Insulation	3" (76)	-	R-15 (2.64 RSI)	1.8 (28)	0.29 (1220)
8	Metal Cladding with 1/2" vented airspace incorporated into exterior heat transfer coefficient					
9	Concrete Slab	8 5/8" (220)	12.5 (1.8)	-	140 (2250)	0.20 (850)
10	Steel Beam W8x18 (W200x27)	-	347 (50)	-	489 (7830)	0.12 (500)
11	Steel Bearing Plates	3/4" (20)	347 (50)	-	489 (7830)	0.12 (500)
12	Steel Bolts and Rebar	-	347 (50)	-	489 (7830)	0.12 (500)
13	Stainless Steel Anchors	-	118 (17)	-	500 (8000)	0.12 (500)
14	Exterior Film ¹	-	-	R-0.2 to R-0.7 (0.03 RSI to 0.12 RSI)	-	-

¹ Value selected from table 1, p. 26.1 of 2009 ASHRAE Handbook – Fundamentals depending on surface orientation

Detail 5.7.6

Exterior Insulated 3 5/8" x 1 5/8" Steel Stud (16" o.c.) Wall Assembly with Intermittent Vertical Z-girts (16" o.c.) Supporting Metal Cladding – Concrete Floor to Steel Beam with a Thermal Isolator Pad Connection

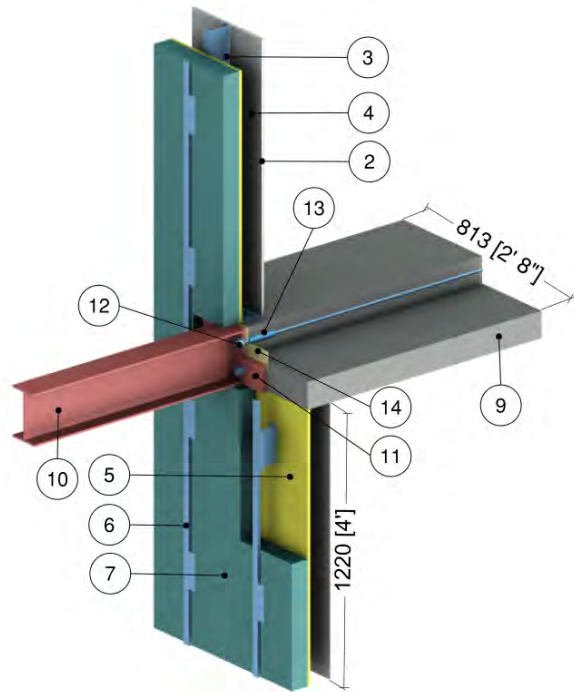

ID	Component	Thickness Inches (mm)	Conductivity Btu-in / ft ² ·hr·°F (W/m K)	Nominal Resistance hr·ft ² ·°F/Btu (m ² K/W)	Density lb/ft ³ (kg/m ³)	Specific Heat Btu/lb·°F (J/kg K)
1	Interior Film ¹	-	-	R-0.6 to R-0.9 (0.11 RSI to 0.16 RSI)	-	-
2	Gypsum Board	1/2" (13)	1.1 (0.16)	R-0.5 (0.08 RSI)	50 (800)	0.26 (1090)
3	3 5/8" x 1 5/8" Steel Studs with Top and Bottom Tracks	18 Gauge	430 (62)	-	489 (7830)	0.12 (500)
4	Air Cavity	3 5/8" (92)	-	R-0.9 (0.16 RSI)	0.075 (1.2)	0.24 (1000)
5	Exterior Sheathing	1/2" (13)	1.1 (0.16)	R-0.5 (0.08 RSI)	50 (800)	0.26 (1090)
6	Intermittent Vertical Z-Girts with 1 1/2" Flange	18 Gauge	430 (62)	-	489 (7830)	0.12 (500)
7	Exterior Insulation	3" (76)	-	R-15 (2.64 RSI)	1.8 (28)	0.29 (1220)
8	Metal Cladding with 1/2" vented airspace incorporated into exterior heat transfer coefficient					
9	Concrete Slab	8 5/8" (220)	12.5 (1.8)	-	140 (2250)	0.20 (850)
10	Steel Beam W8x18 (W200x27)	-	347 (50)	-	489 (7830)	0.12 (500)
11	Steel Bearing Plates	3/4" (20)	347 (50)	-	489 (7830)	0.12 (500)
12	Steel Bolts and Rebar	-	347 (50)	-	489 (7830)	0.12 (500)
13	Stainless Steel Anchors	-	118 (17)	-	500 (8000)	0.12 (500)
14	Polymer Thermal Isolator Pad	3/8" (10)	1.7 (0.25)	-	137 (2200)	0.31 (1300)
15	Exterior Film ¹	-	-	R-0.2 to R-0.7 (0.03 RSI to 0.12 RSI)	-	-

¹ Value selected from table 1, p. 26.1 of 2009 ASHRAE Handbook – Fundamentals depending on surface orientation

Detail 5.7.7

Exterior Insulated 3 5/8" x 1 5/8" Steel Stud (16" o.c.) Wall Assembly with Intermittent Vertical Z-girts (16" o.c.) Supporting Metal Cladding – Concrete Floor to Steel Beam with Isokorb KS14 Connection

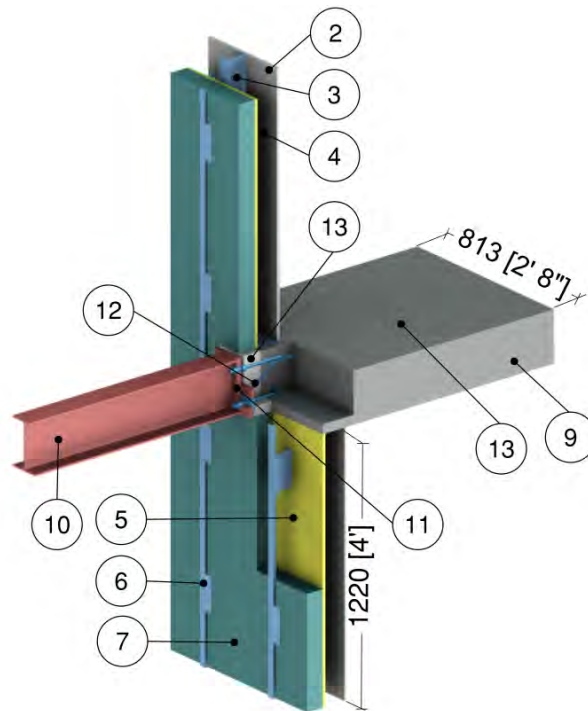

ID	Component	Thickness Inches (mm)	Conductivity Btu-in / ft ² -hr-°F (W/m K)	Nominal Resistance hr-ft ² -°F/Btu (m ² K/W)	Density lb/ft ³ (kg/m ³)	Specific Heat Btu/lb-°F (J/kg K)
1	Interior Film ¹	-	-	R-0.6 to R-0.9 (0.11 RSI to 0.16 RSI)	-	-
2	Gypsum Board	1/2" (13)	1.1 (0.16)	R-0.5 (0.08 RSI)	50 (800)	0.26 (1090)
3	3 5/8" x 1 5/8" Steel Studs with Top and Bottom Tracks	18 Gauge	430 (62)	-	489 (7830)	0.12 (500)
4	Air Cavity	3 5/8" (92)	-	R-0.9 (0.16 RSI)	0.075 (1.2)	0.24 (1000)
5	Exterior Sheathing	1/2" (13)	1.1 (0.16)	R-0.5 (0.08 RSI)	50 (800)	0.26 (1090)
6	Intermittent Vertical Z-Girts with 1 1/2" Flange	18 Gauge	430 (62)	-	489 (7830)	0.12 (500)
7	Exterior Insulation	3" (76)	-	R-15 (2.64 RSI)	1.8 (28)	0.29 (1220)
8	Metal Cladding with 1/2" vented airspace incorporated into exterior heat transfer coefficient					
9	Concrete Slab	8 5/8" (220)	12.5 (1.8)	-	140 (2250)	0.20 (850)
10	Steel Beam W8x18 (W200x27)	-	347 (50)	-	489 (7830)	0.12 (500)
11	Steel Bearing Plate with Butt Stop	3/4" (20)	347 (50)	-	489 (7830)	0.12 (500)
Isokorb KS14 Thermal Break						
12	Stainless Steel Reinforcement	-	118 (17)	-	500 (8000)	0.12 (500)
13	Polystyrene Hard Foam Insulation	3 1/8" (80)	0.217 (0.031)	R-14.5 (2.6 RSI)	66 (1060)	0.35 (1500)
14	Exterior Film ¹	-	-	R-0.2 to R-0.7 (0.03 RSI to 0.12 RSI)	-	-

¹ Value selected from table 1, p. 26.1 of 2009 ASHRAE Handbook – Fundamentals depending on surface orientation

Detail 5.7.8

Exterior and Interior Insulated 3 5/8" x 1 5/8" Steel Stud (16" o.c.) Wall Assembly with Horizontal Z-girts (24" o.c.) Supporting Metal Cladding and R-12 Batt Insulation in Stud Cavity – Structural Steel Floor Intersection with Beam Thermal Break

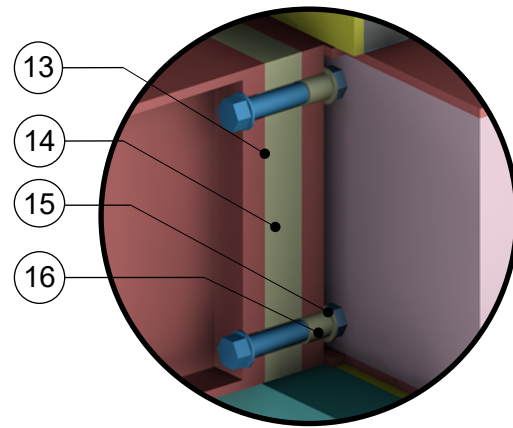
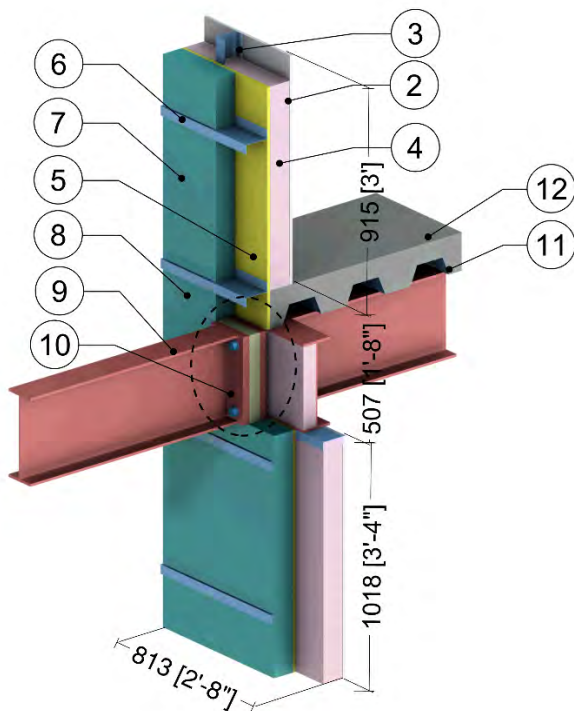

Beam Thermal Break

ID	Component	Thickness Inches (mm)	Conductivity Btu-in / ft ² ·hr·°F (W/m K)	Nominal Resistance hr·ft ² ·°F/Btu (m ² K/W)	Density lb/ft ³ (kg/m ³)	Specific Heat Btu/lb·°F (J/kg K)
1	Interior Film ¹	-	-	R-0.6 (0.11 RSI) to R-0.9 (0.16 RSI)	-	-
2	Gypsum Board	1/2" (13)	1.1 (0.16)	R-0.5 (0.08 RSI)	50 (800)	0.26 (1090)
3	3 5/8" x 1 5/8" Steel Studs with Top and Bottom Tracks	18 Gauge	430 (62)	-	489 (7830)	0.12 (500)
4	Fibreglass Batt Insulation	3 5/8" (92)	0.30 (0.043)	R-12.0 (2.10 RSI)	0.9 (14)	0.17 (710)
5	Exterior Sheathing	1/2" (13)	1.1 (0.16)	R-0.5 (0.09 RSI)	50 (800)	0.26 (1090)
6	Horizontal Z-girts with 1 1/2" Flange	18 Gauge	430 (62)	-	489 (7830)	0.12 (500)
7	Exterior Insulation	3" (76)	0.2 (0.029)	R-15.0 (2.64 RSI)	1.8 (28)	0.29 (1220)
8	Metal Cladding with 1/2" vented airspace incorporated into exterior heat transfer coefficient					
9	Steel Beam W14x26 (W360x39)	-	347 (50)	-	489 (7830)	0.12 (500)
10	Steel Bearing Plates	1 3/16" (30)	347 (50)	-	489 (7830)	0.12 (500)
11	Steel Deck	1/16" (1.6)	347 (50)	-	489 (7830)	0.12 (500)
12	Concrete Topping	6" (152)	6.3 (0.9)	-	120 (1920)	0.20 (850)
13	Steel or Stainless Steel Bolts	-	347 (50) to 118 (17)	-	500 (8000)	0.12 (500)
14	Armatherm FRR Break	1" to 2" (25 to 50)	1.4 (0.20)	-	85 (5.3)	-
15	Armatherm FRR Washer	3/8" (10)	1.4 (0.20)	-	85 (5.3)	-
16	Armatherm FRR Bushing	1.2" (30)	1.4 (0.20)	-	85 (5.3)	-
17	Exterior Film ¹	-	-	R-0.7 (0.12 RSI)	-	-

¹ Value selected from table 1, p. 26.1 of 2009 ASHRAE Handbook – Fundamentals depending on surface orientation

Detail 5.7.9

Exterior and Interior Insulated 3 5/8" x 1 5/8" Steel Stud (16" o.c.) Wall Assembly with Horizontal Z-girts (24" o.c.) Supporting Metal Cladding and R-12 Batt Insulation in Stud Cavity – Structural Steel Floor Intersection with Aerolon Coating

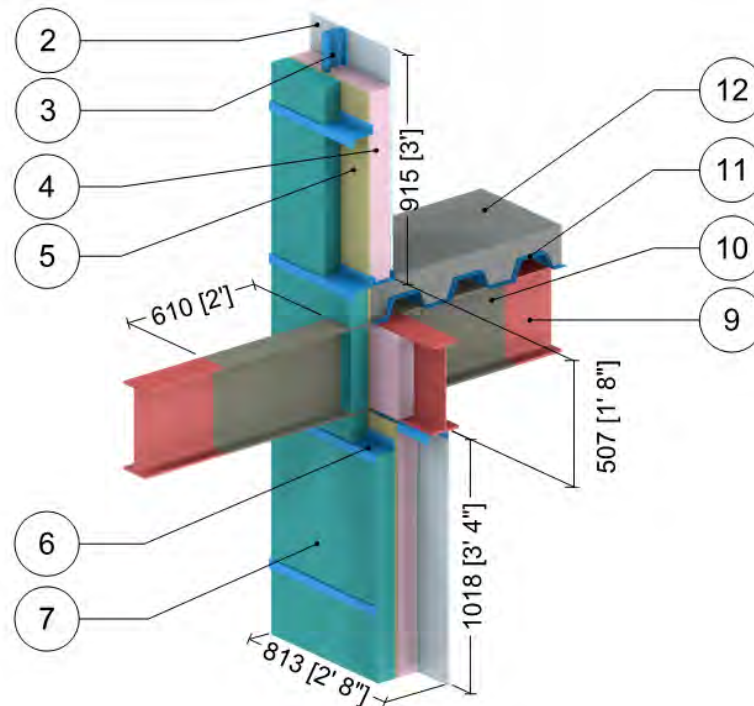

ID	Component	Thickness Inches (mm)	Conductivity Btu-in / ft ² ·hr·°F (W/m K)	Nominal Resistance hr·ft ² ·°F/Btu (m ² K/W)	Density lb/ft ³ (kg/m ³)	Specific Heat Btu/lb·°F (J/kg K)
1	Interior Film ¹	-	-	R-0.6 to R-0.9 (0.11 RSI to 0.16 RSI)	-	-
2	Gypsum Board	1/2" (13)	1.1 (0.16)	R-0.5 (0.08 RSI)	50 (800)	0.26 (1090)
3	3 5/8" x 1 5/8" Steel Studs with Top and Bottom Tracks	18 Gauge	430 (62)	-	489 (7830)	0.12 (500)
4	Fibreglass Batt Insulation	3 5/8" (92)	0.30 (0.043)	R-12.0 (2.10 RSI)	0.9 (14)	0.17 (710)
5	Exterior Sheathing	1/2" (13)	1.1 (0.16)	R-0.5 (0.08 RSI)	50 (800)	0.26 (1090)
6	Horizontal Z-girts with 1 1/2" Flange	18 Gauge	430 (62)	-	489 (7830)	0.12 (500)
7	Exterior Insulation	3" (76)	0.2 (0.029)	R-15.0 (2.64 RSI)	1.8 (28)	0.29 (1220)
8	Metal Cladding with 1/2" vented airspace incorporated into exterior heat transfer coefficient					
9	Steel Beam W14x26 (W360x39)	-	347 (50)	-	489 (7830)	0.12 (500)
10	Aerolon Coating	0.098" (2.5)	-	R-0.4 (0.07 RSI)	-	-
11	Steel Deck	1/16" (1.6)	347 (50)	-	489 (7830)	0.12 (500)
12	Concrete Topping	6" (152)	6.3 (0.9)	-	120 (1920)	0.20 (850)
13	Exterior Film ¹	-	-	R-0.7 (0.12 RSI)	-	-

¹ Value selected from table 1, p. 26.1 of 2009 ASHRAE Handbook – Fundamentals depending on surface orientation

Detail 5.7.10

Exterior Insulated 6" x 1 5/8" Steel Stud (16" o.c.) Wall Assembly with FRP Vertical Brackets and Rail System Supporting Metal Cladding – Structural Steel Column & Knife Edge Cable Support Intersection

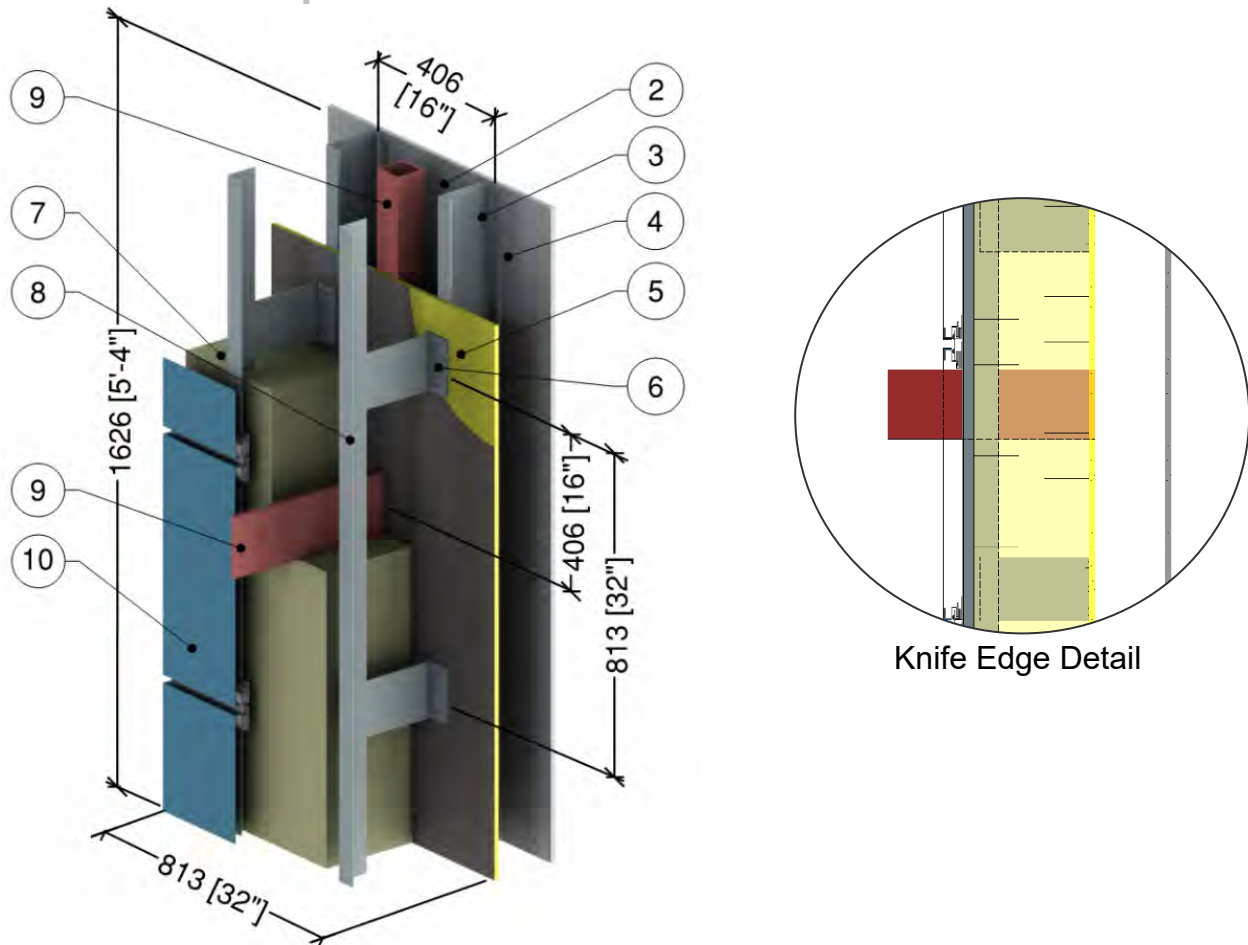

ID	Component	Thickness Inches (mm)	Conductivity Btu-in / ft ² ·hr·°F (W/m K)	Nominal Resistance hr·ft ² ·°F/Btu (m ² K/W)	Density lb/ft ³ (kg/m ³)	Specific Heat Btu/lb·°F (J/kg K)
1	Interior Film ¹	-	-	R-0.7 (0.12 RSI)	-	-
2	Gypsum Board	1/2" (13)	1.1 (0.16)	R-0.5 (0.08 RSI)	50 (800)	0.26 (1090)
3	6" x 1 5/8" Steel Studs with Tracks	18 Gauge	430 (62)	-	489 (7830)	0.12 (500)
4	Air in Stud Cavity	6" (152)	-	R-0.9 (0.16 RSI)	-	0.24 (1000)
5	Exterior Sheathing	1/2" (13)	1.1 (0.16)	R-0.5 (0.08 RSI)	50 (800)	0.26 (1090)
6	FRP Bracket	-	4.85 (0.7)	-	110 (1760)	-
7	Exterior Mineral Wool Insulation	10" (254)	0.24 (0.034)	R-42 (7.40 RSI)	4.5 (72)	0.20 (850)
8	Vertical Aluminum L-Rail	0.09" (2.2)	1110 (160)	-	171 (2739)	0.22 (900)
9	Steel Column and Knife Edge	5/8" (16)	430 (62)	-	489 (7830)	0.12 (500)
10	Metal Cladding with 1/2" vented airspace incorporated into exterior heat transfer coefficient					
11	Exterior Film ¹	-	-	R-0.7 (0.12 RSI)	-	-

¹ Value selected from table 1, p. 26.1 of 2009 ASHRAE Handbook – Fundamentals depending on surface orientation

Detail 5.7.11

Exterior and Interior Insulated 6" x 1 5/8" Steel Stud (16" o.c.) Wall Assembly with FRP Vertical Brackets and Rail System Supporting Metal Cladding with R-19 Batt in Stud Cavity – Structural Steel Column & Knife Edge Cable Support Intersection

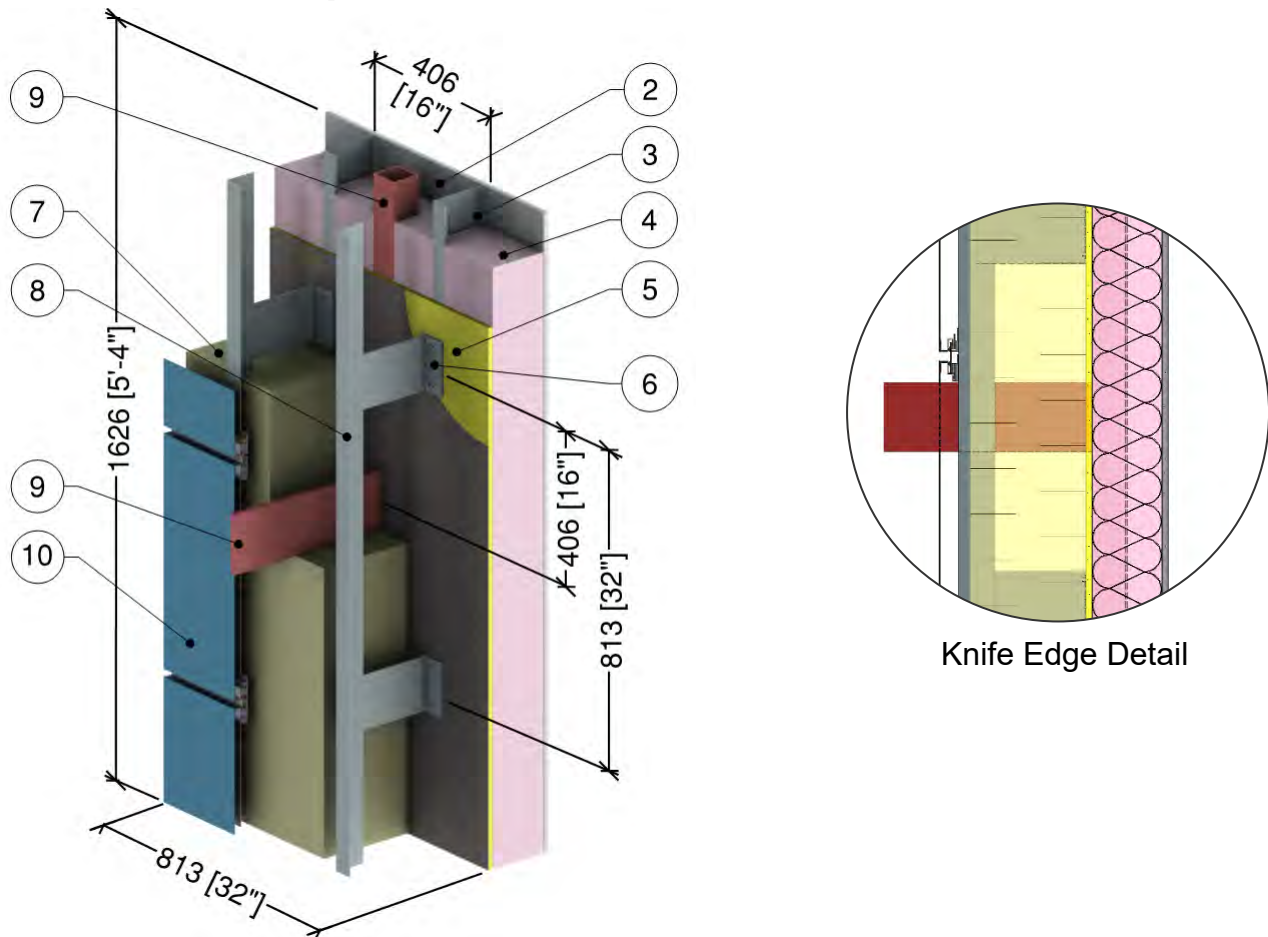

ID	Component	Thickness Inches (mm)	Conductivity Btu-in / ft ² ·hr·°F (W/m K)	Nominal Resistance hr·ft ² ·°F/Btu (m ² K/W)	Density lb/ft ³ (kg/m ³)	Specific Heat Btu/lb·°F (J/kg K)
1	Interior Film ¹	-	-	R-0.7 (0.12 RSI)	-	-
2	Gypsum Board	1/2" (13)	1.1 (0.16)	R-0.5 (0.08 RSI)	50 (800)	0.26 (1090)
3	6" x 1 5/8" Steel Studs with Tracks	18 Gauge	430 (62)	-	489 (7830)	0.12 (500)
4	Fiberglass Batt Insulation	6" (152)	0.32 (0.046)	R-19 (3.35 RSI)	0.9 (14)	0.17 (710)
5	Exterior Sheathing	1/2" (13)	1.1 (0.16)	R-0.5 (0.08 RSI)	50 (800)	0.26 (1090)
6	FRP Bracket	-	4.85 (0.7)	-	110 (1760)	-
7	Exterior Mineral Wool Insulation	10" (254)	0.24 (0.034)	R-42 (7.40 RSI)	4.5 (72)	0.20 (850)
8	Vertical Aluminum L-Rail	0.09" (2.2)	1110 (160)	-	171 (2739)	0.22 (900)
9	Steel Column and Knife Edge	5/8" (16)	430 (62)	-	489 (7830)	0.12 (500)
10	Metal Cladding with 1/2" vented airspace incorporated into exterior heat transfer coefficient					
11	Exterior Film ¹	-	-	R-0.7 (0.12 RSI)	-	-

¹ Value selected from table 1, p. 26.1 of 2009 ASHRAE Handbook – Fundamentals depending on surface orientation

Detail 5.7.12

Exterior and Interior Insulated 3 5/8" x 1 5/8" Steel Stud (16" o.c.) Wall Assembly with Horizontal Z-girts (24" o.c.) Supporting Metal Cladding and R-12 Batt Insulation in Stud Cavity – Structural Steel Floor Intersection with Thermal Isolator Pad

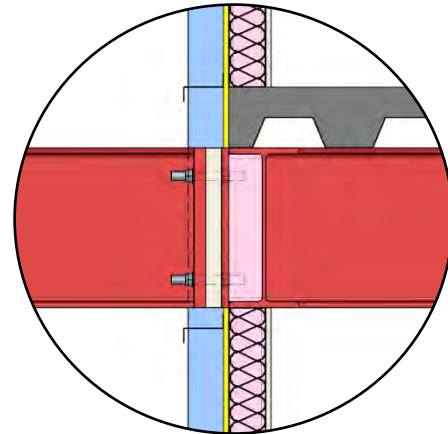
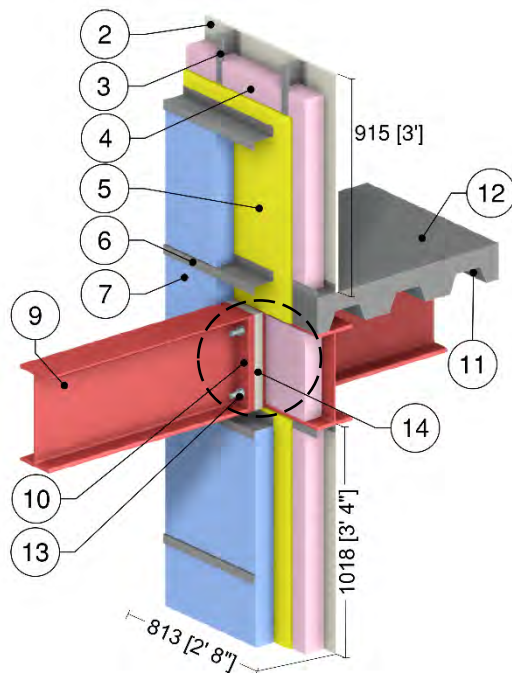

Structural Steel
Beam Detail

ID	Component	Thickness Inches (mm)	Conductivity Btu-in / ft ² ·hr·°F (W/m K)	Nominal Resistance hr·ft ² ·°F/Btu (m ² K/W)	Density lb/ft ³ (kg/m ³)	Specific Heat Btu/lb·°F (J/kg K)
1	Interior Film ¹	-	-	R-0.6 to R-0.9 (0.11 RSI to 0.16 RSI)	-	-
2	Gypsum Board	1/2" (13)	1.1 (0.16)	R-0.5 (0.08 RSI)	50 (800)	0.26 (1090)
3	3 5/8" x 1 5/8" Steel Studs with Top and Bottom Tracks	18 Gauge	430 (62)	-	489 (7830)	0.12 (500)
4	Fibreglass Batt Insulation	3 5/8" (92)	0.30 (0.044)	R-12.0 (2.10 RSI)	0.9 (14)	0.17 (710)
5	Exterior Sheathing	1/2" (13)	1.1 (0.16)	R-0.5 (0.08 RSI)	50 (800)	0.26 (1090)
6	Horizontal Z-girts with 1 1/2" Flange	18 Gauge	430 (62)	-	489 (7830)	0.12 (500)
7	Exterior Insulation	3" (76)	0.20 (0.029)	R-15.0 (2.64 RSI)	1.8 (28)	0.29 (1220)
8	Metal Cladding with 1/2" vented airspace incorporated into exterior heat transfer coefficient					
9	Steel Beam W14x26 (W360x39)	-	347 (50)	-	489 (7830)	0.12 (500)
10	Steel Bearing Plates	1 3/16" (30)	347 (50)	-	489 (7830)	0.12 (500)
11	Steel Deck	18 Gauge	430 (62)	-	489 (7830)	0.12 (500)
12	Concrete Topping	6" (152)	12.5 (1.8)	-	140 (2250)	0.20 (850)
13	Stainless Steel or Steel Bolts and Bushings	-	118 to 347 (17 to 50)	-	500 (8000)	0.12 (500)
14	Polymer Thermal Isolator Pad	1" to 2" (25 to 50)	1.7 (0.25)	-	137 (2200)	0.31 (1300)
15	Exterior Film ¹	-	-	R-0.2 to R-0.7 (0.03 RSI to 0.12 RSI)	-	-

¹ Value selected from table 1, p. 26.1 of 2009 ASHRAE Handbook – Fundamentals depending on surface orientation

Detail 5.7.13

Exterior and Interior Insulated 3 5/8" x 1 5/8" Steel Stud (16" o.c.) Wall Assembly with Horizontal Z-girts (24" o.c.) Supporting Metal Cladding and R-12 Batt Insulation in Stud Cavity – Structural Steel Floor Intersection with Isokorb KST System Thermally Broken Beam

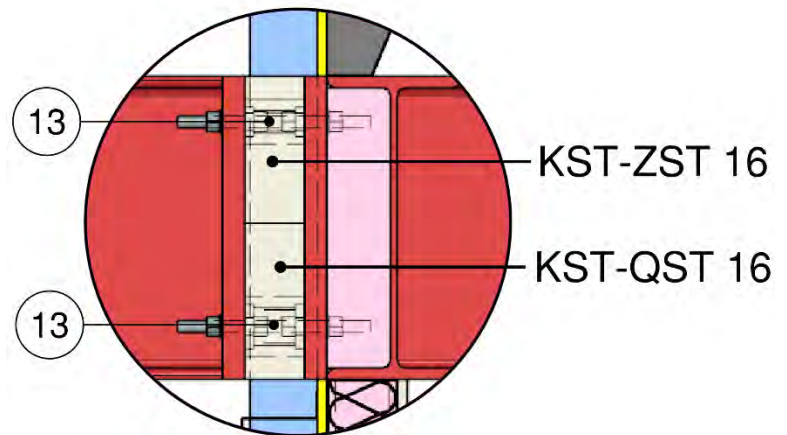
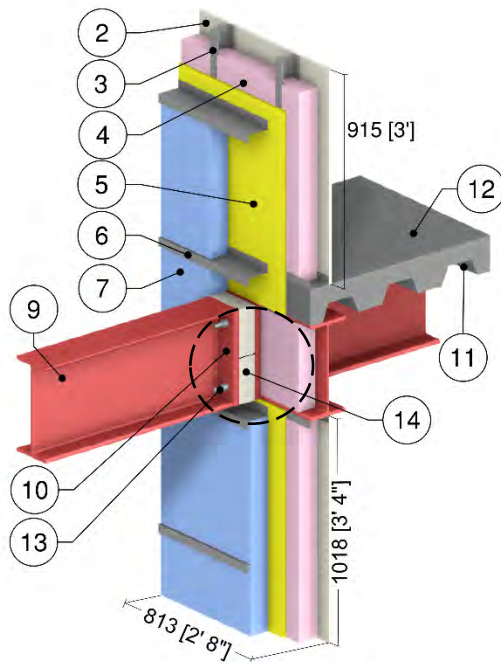

KST System Detail

ID	Component	Thickness Inches (mm)	Conductivity Btu-in / ft ² ·hr·°F (W/m K)	Nominal Resistance hr·ft ² ·°F/Btu (m ² K/W)	Density lb/ft ³ (kg/m ³)	Specific Heat Btu/lb·°F (J/kg K)
1	Interior Film ¹	-	-	R-0.6 to R-0.9 (0.11 RSI to 0.16 RSI)	-	-
2	Gypsum Board	1/2" (13)	1.1 (0.16)	R-0.5 (0.08 RSI)	50 (800)	0.26 (1090)
3	3 5/8" x 1 5/8" Steel Studs with Top and Bottom Tracks	18 Gauge	430 (62)	-	489 (7830)	0.12 (500)
4	Fibreglass Batt Insulation	3 5/8" (92)	0.30 (0.044)	R-12.0 (2.10 RSI)	0.9 (14)	0.17 (710)
5	Exterior Sheathing	1/2" (13)	1.1 (0.16)	R-0.5 (0.08 RSI)	50 (800)	0.26 (1090)
6	Horizontal Z-girts with 1 1/2" Flange	18 Gauge	430 (62)	-	489 (7830)	0.12 (500)
7	Exterior Insulation	3" (76)	0.20 (0.029)	R-15.0 (2.64 RSI)	1.8 (28)	0.29 (1220)
8	Metal Cladding with 1/2" vented airspace incorporated into exterior heat transfer coefficient					
9	Steel Beam W14x26 (W360x39)	-	347 (50)	-	489 (7830)	0.12 (500)
10	Steel Bearing Plates	1 3/16" (30)	347 (50)	-	489 (7830)	0.12 (500)
11	Steel Deck	18 Gauge	430 (62)	-	489 (7830)	0.12 (500)
12	Concrete Topping	6" (152)	12.5 (1.8)	-	140 (2250)	0.20 (850)
	Isokorb KST System Thermal Break					
13	Stainless Steel Bolts, Plates and HSS	-	118 (17)	-	500 (8000)	0.12 (500)
14	Polystyrene Insulation	3.2" (80)	0.22 (0.031)	R-15 (2.58 RSI)	1.3 (20)	0.35 (1500)
15	Exterior Film ¹	-	-	R-0.2 to R-0.7 .2 to (0.03RSI to 0.12 RSI)	-	-

¹ Value selected from table 1, p. 26.1 of 2009 ASHRAE Handbook – Fundamentals depending on surface orientation

Detail 5.8.1

Exterior and Interior Insulated 3 5/8" x 1 5/8" Steel Stud (16" o.c.) Wall Assembly with Horizontal Z-Girts (24" o.c.) Supporting Metal Cladding and R-12 Batt Insulation in Stud Cavity – Interior Wall Intersection

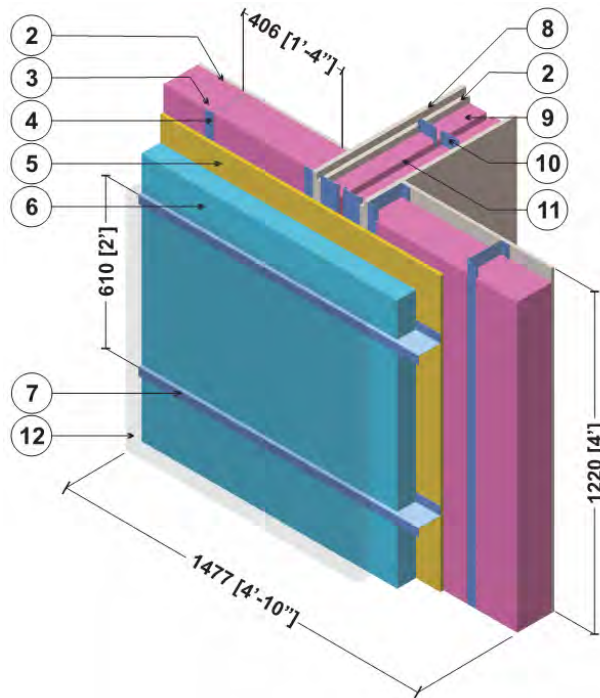

ID	Component	Thickness Inches (mm)	Conductivity Btu-in / ft ² ·hr·°F (W/m K)	Nominal Resistance hr·ft ² ·°F/Btu (m ² K/W)	Density lb/ft ³ (kg/m ³)	Specific Heat Btu/lb·°F (J/kg K)
1	Interior Film ¹	-	-	R-0.7 (0.12 RSI)	-	-
2	Gypsum Board	1/2" (13)	1.1 (0.16)	R-0.5 (0.08 RSI)	50 (800)	0.26 (1090)
3	Fiberglass Batt Insulation	3 5/8" (92)	0.31 (0.044)	R-12 (2.1 RSI)	0.9 (14)	0.17 (710)
4	3 5/8" x 1 5/8" Steel Studs	18 Gauge	430 (62)	-	489 (7830)	0.12 (500)
5	Exterior Sheathing	1/2" (13)	1.1 (0.16)	R-0.5 (0.08 RSI)	50 (800)	0.26 (1090)
6	Exterior Insulation	Varies	-	R-5 to R-25 (0.88 RSI to 4.4 RSI)	1.8 (28)	0.29 (1220)
7	Horizontal Z-girts w/ 1 1/2" Flange	18 Gauge	430 (62)	-	489 (7830)	0.12 (500)
8	Gypsum Board	5/8" (16)	1.1 (0.16)	R-0.5 (0.08 RSI)	50 (800)	0.26 (1090)
9	Acoustic Batt Insulation	2 5/8" (67)	0.29 (0.042)	-	0.9 (14)	0.17 (710)
10	2 5/8" x 1 5/8" Steel Studs	18 Gauge	430 (62)	-	489 (7830)	0.12 (500)
11	Air Gap	1" (25)	-	R-0.9 (0.16 RSI)	0.075 (1.2)	0.24 (1000)
12	Metal cladding with 1/2" (13mm) vented air space is incorporated into exterior heat transfer coefficient					
13	Exterior Film ¹	-	-	R-0.7 (0.12 RSI)	-	-

¹ Value selected from table 1, p. 26.1 of 2009 ASHRAE Handbook – Fundamentals depending on surface orientation

Detail 5.8.2

Exterior Insulated 6" x 1 5/8" Steel Stud (16" o.c.) Wall Assembly with FRP Vertical Brackets and Rail System Supporting Metal Cladding – At-Grade Foundation Wall Intersection

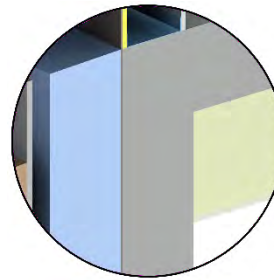
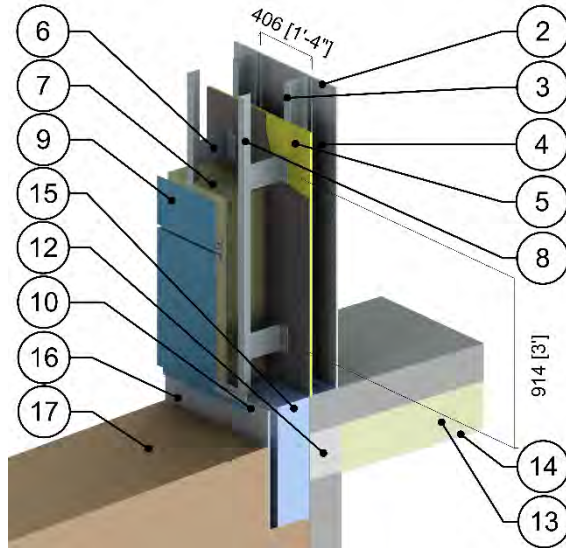

Scenario A - Without Thermal Break

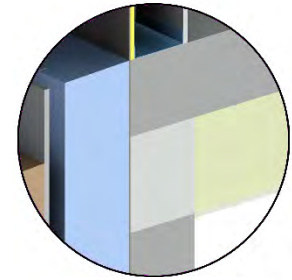

Scenario B - With Thermal Break

ID	Component	Thickness Inches (mm)	Conductivity Btu-in / ft ² -hr-°F (W/m K)	Nominal Resistance hr-ft ² -°F/Btu (m ² K/W)	Density lb/ft ³ (kg/m ³)	Specific Heat Btu/lb-°F (J/kg K)
1	Interior Film ¹	-	-	R-0.7 to R-0.9 (0.12 to 0.16 RSI)	-	-
2	Gypsum Board	1/2" (13)	1.1 (0.16)	R-0.5 (0.08 RSI)	50 (800)	0.26 (1090)
3	6" x 1 5/8" Steel Studs with Tracks	18 Gauge	430 (62)	-	489 (7830)	0.12 (500)
4	Air in Stud Cavity	6" (152)	-	R-0.9 (0.16 RSI)	-	0.24 (1000)
5	Exterior Sheathing	1/2" (13)	1.1 (0.16)	R-0.5 (0.08 RSI)	50 (800)	0.26 (1090)
6	FRP Bracket	-	4.9 (0.70)	-	110 (1760)	-
7	Exterior Mineral Wool Insulation	10" (254)	0.24 (0.034)	R-42 (7.40 RSI)	4.5 (72)	0.20 (850)
8	Vertical Aluminum L-Rail	0.09" (2.2)	1110 (160)	-	171 (2739)	0.22 (900)
9	Metal Cladding with 1/2" vented airspace incorporated into exterior heat transfer coefficient					
10	Aluminum Flashing	18 Gauge	1110 (160)	-	171 (2739)	0.22 (900)
11	Concrete Foundation	8" (203)	12.5 (1.8)	-	140 (2250)	0.20 (850)
12	Foundation Thermal Block	8" (203)	0.20 (0.029)	R-40 (7.04 RSI)	1.8 (28)	0.29 (1220)
13	Slab Insulation	10" (254)	0.24 (0.034)	R-42 (7.40 RSI)	4.5 (72)	0.20 (850)
14	Gypsum Thermal Protection Board	1/2" (13)	1.1 (0.16)	R-0.5 (0.08 RSI)	50 (800)	0.26 (1090)
15	Below Grade Rigid Insulation	8" (203)	0.20 (0.029)	R-40 (7.04 RSI)	1.8 (28)	0.29 (1220)
16	Cement Protection Board	1/2" (13)	12.5 (1.8)	-	140 (2250)	0.20 (850)
17	Soil	-	15.6 (2.25)	-	-	-
18	Exterior Film ¹	-	-	R-0.2 to R-0.7 (0.03 to 0.12 RSI)	-	-

¹ Value selected from table 1, p. 26.1 of 2009 ASHRAE Handbook – Fundamentals depending on surface orientation

Detail 5.8.3

Exterior and Interior Insulated 6" x 1 5/8" Steel Stud (16" o.c.) Wall Assembly with FRP Vertical Brackets and Rail System Supporting Metal Cladding and R19 Batt Insulation in Stud Cavity – At-Grade Foundation Wall Intersection

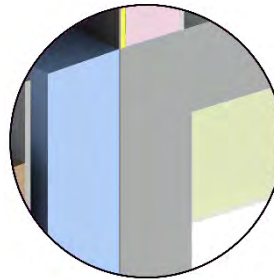
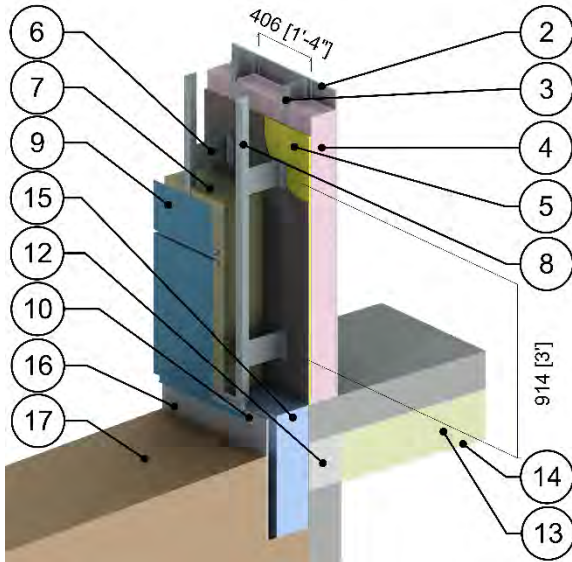

Scenario A - Without Thermal Break

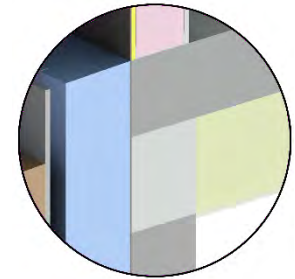

Scenario B - With Thermal Break

ID	Component	Thickness Inches (mm)	Conductivity Btu-in / ft ² ·hr·°F (W/m K)	Nominal Resistance hr·ft ² ·°F/Btu (m ² K/W)	Density lb/ft ³ (kg/m ³)	Specific Heat Btu/lb·°F (J/kg K)
1	Interior Film ¹	-	-	R-0.7 to R-0.9 (0.12 to 0.16 RSI)	-	-
2	Gypsum Board	1/2" (13)	1.1 (0.16)	R-0.5 (0.08 RSI)	50 (800)	0.26 (1090)
3	6" x 1 5/8" Steel Studs with Tracks	18 Gauge	430 (62)	-	489 (7830)	0.12 (500)
4	Fiberglass Batt Insulation	6" (152)	0.32 (0.046)	R-19 (3.35 RSI)	0.9 (14)	0.17 (710)
5	Exterior Sheathing	1/2" (13)	1.1 (0.16)	R-0.5 (0.08 RSI)	50 (800)	0.26 (1090)
6	FRP Bracket	-	4.9 (0.70)	-	110 (1760)	-
7	Exterior Mineral Wool Insulation	10" (254)	0.24 (0.034)	R-42 (7.40 RSI)	4.5 (72)	0.20 (850)
8	Vertical Aluminum L-Rail	0.09" (2.2)	1110 (160)	-	171 (2739)	0.22 (900)
9	Metal Cladding with 1/2" vented airspace incorporated into exterior heat transfer coefficient					
10	Aluminum Flashing	18 Gauge	1110 (160)	-	171 (2739)	0.22 (900)
11	Concrete Foundation	8" (203)	12.5 (1.8)	-	140 (2250)	0.20 (850)
12	Foundation Thermal Block	8" (203)	0.20 (0.029)	R-40 (7.04 RSI)	1.8 (28)	0.29 (1220)
13	Slab Insulation	10" (254)	0.24 (0.034)	R-42 (7.40 RSI)	4.5 (72)	0.20 (850)
14	Gypsum Thermal Protection Board	1/2" (13)	1.1 (0.16)	R-0.5 (0.08 RSI)	50 (800)	0.26 (1090)
15	Below Grade Rigid Insulation	8" (203)	0.20 (0.029)	R-40 (7.04 RSI)	1.8 (28)	0.29 (1220)
16	Cement Protection Board	1/2" (13)	12.5 (1.8)	-	140 (2250)	0.20 (850)
17	Soil	-	15.6 (2.25)	-	-	-
18	Exterior Film ¹	-	-	R-0.2 to R-0.7 (0.03 to 0.12 RSI)	-	-

¹ Value selected from table 1, p. 26.1 of 2009 ASHRAE Handbook – Fundamentals depending on surface orientation

6.0 Metal Buildings

Detail 6.1.1	A.6.1
Vertical Insulated Metal Panel – Clear Wall with Vertical Connection Joint and Support Girt/Hat Track Backup Wall	
Detail 6.1.2	A.6.2
Vertical Insulated Metal Panel – Metal Stack Joint and Support Girt Back/Hat Track Backup Wall	
Detail 6.1.3	A.6.3
Horizontal Insulated Metal Panel – Clear Wall with Horizontal Connection Joint and Steel Stud Backup Wall	
Detail 6.1.4	A.6.4
Horizontal Insulated Metal Panel – Vertical Gasket Joint with Steel Stud Backup Wall	
Detail 6.1.5	A.6.5
Structural Sheet Steel Wall with Cladding Supported by Notched Z-Bar for Baseline System – Clear Wall	
Detail 6.1.6	A.6.6
Structural Sheet Steel Wall with Cladding Supported by Intermittent Notched Z-Bar – Clear Wall	
Detail 6.1.7	A.6.7
Structural Sheet Steel Wall with Cladding Supported by Thermal Chairs – Clear Wall	
Detail 6.1.8	A.6.8
2 Hour Fire Rated Structural Steel Sheet Wall with Cladding Supported by Notched Z-bar with Ceramic Blanket – Clear Wall	
Detail 6.2.1	A.6.9
Vertical Insulated Metal Panel - Corrugated Slab Intersection with I-beam – Open Web Steel Joist and Support Girt/Hat Track Backup Wall	
Detail 6.2.2	A.6.10
Horizontal Insulated Metal Panel – Corrugated Slab Intersection with I-beam – Open Web Steel Joist and Steel Stud Backup Wall	
Detail 6.3.1	A.6.11
Vertical Insulated Metal Panel – Window Glazing Transition with Steel Support Framing	
Detail 6.3.2	A.6.12
Horizontal Insulated Metal Panel – Window Glazing Transition with Steel Support Framing	
Detail 6.4.1	A.6.13
Vertical Insulated Metal Panel – Steel Roof Deck with Open Web Steel Joist & Parapet Intersection	

Detail 6.4.2A.6.14

Horizontal Insulated Metal Panel – Steel Roof Deck with Open Web Steel Joist & Parapet Intersection

Detail 6.5.1A.6.15

Vertical Insulated Metal Panel – Corner Intersection with Post and Support Girt/Hat Track Backup Wall

Detail 6.5.2A.6.16

Horizontal Insulated Metal Panel – Corner Intersection with Post and Steel Stud Backup Wall

Detail 6.1.1

Vertical Insulated Metal Panel – Clear Wall with Vertical Connection Joint and Support Girt/Hat Track Backup Wall

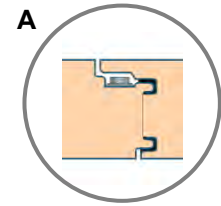
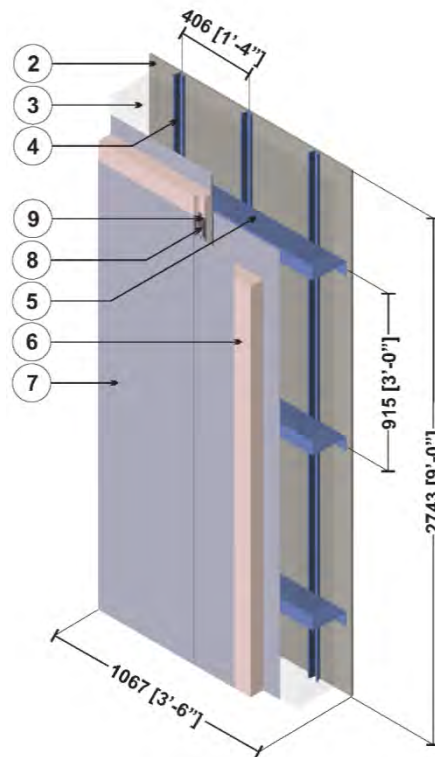

Vertical Joint

ID	Component	Thickness Inches (mm)	Conductivity Btu-in / ft ² ·hr·°F (W/m K)	Nominal Resistance hr·ft ² ·°F/Btu (m ² K/W)	Density lb/ft ³ (kg/m ³)	Specific Heat Btu/lb·°F (J/kg K)
1	Interior Film ¹	-	-	R-0.7 (0.12 RSI)	-	-
2	Gypsum Board	1/2" (13)	1.1 (0.16)	R-0.5 (0.08 RSI)	50 (800)	0.26 (1090)
3	Air in Stud Cavity	-	-	R-0.9 (0.16 RSI)	0.075 (1.2)	0.24 (1000)
4	Hat Tracks @ 16" o.c.	18 Gauge	430 (62)	-	489 (7830)	0.12 (500)
5	Z-Girts with 1 1/2" Flange	16 Gauge	430 (62)	-	489 (7830)	0.12 (500)
6	Polyisocyanurate Insulation	3" (76)	0.143 (0.02)	R-21 (3.70)	1.8 (28)	0.29 (1220)
7	Steel Facer Skin	24 Gauge	430 (62)	-	489 (7830)	0.12 (500)
8	Sealant	Varies	2.4 (0.35)	-	-	-
9	#14 Steel Fasteners	1/4" (6) Ø	314 (45)	-	489 (7830)	0.12 (500)
10	Exterior Film ¹	-	-	R-0.2 (0.03 RSI)	-	-

¹ Value selected from table 1, p. 26.1 of 2009 ASHRAE Handbook – Fundamentals depending on surface orientation

Detail 6.1.2

Vertical Insulated Metal Panel – Metal Stack Joint and Support Girt Back/Hat Track Backup Wall

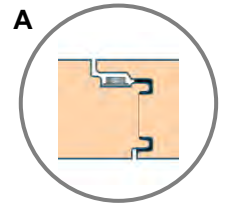
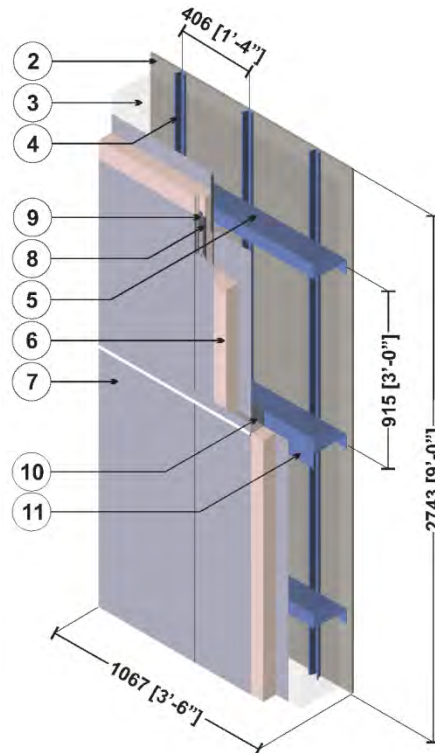

Vertical Joint

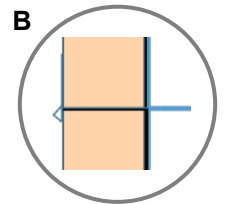

Horizontal Joint

ID	Component	Thickness Inches (mm)	Conductivity Btu·in / ft ² ·hr·°F (W/m K)	Nominal Resistance hr·ft ² ·°F/Btu (m ² K/W)	Density lb/ft ³ (kg/m ³)	Specific Heat Btu/lb·°F (J/kg K)
1	Interior Film ¹	-	-	R-0.7 (0.12 RSI)	-	-
2	Gypsum Board	1/2" (13)	1.1 (0.16)	R-0.5 (0.08 RSI)	50 (800)	0.26 (1090)
3	Air in Stud Cavity	-	-	R-0.9 (0.16 RSI)	0.075 (1.2)	0.24 (1000)
4	Hat Tracks @ 16" o.c.	18 Gauge	430 (62)	-	489 (7830)	0.12 (500)
5	Z-Girts with 1 1/2" Flange	16 Gauge	430 (62)	-	489 (7830)	0.12 (500)
6	Polyisocyanurate Insulation	3" (76)	0.143 (0.020)	R-21 (3.70)	1.8 (28)	0.29 (1220)
7	Steel Facer Skin	24 Gauge	430 (62)	-	489 (7830)	0.12 (500)
8	Sealant	Varies	2.4 (0.35)	-	-	-
9	#14 Steel Fasteners	1/4" (6) Ø	314 (45)	-	489 (7830)	0.12 (500)
10	Steel Flashing & Trim	18 Gauge	430 (62)	-	489 (7830)	0.12 (500)
11	Steel Angle	16 Gauge	430 (62)	-	489 (7830)	0.12 (500)
12	Exterior Film ¹	-	-	R-0.2 (0.03 RSI)	-	-

¹ Value selected from table 1, p. 26.1 of 2009 ASHRAE Handbook – Fundamentals depending on surface orientation

Detail 6.1.3

Horizontal Insulated Metal Panel – Clear Wall with Horizontal Connection Joint and Steel Stud Backup Wall

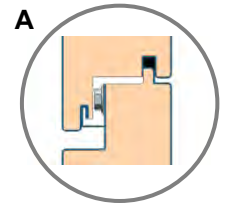
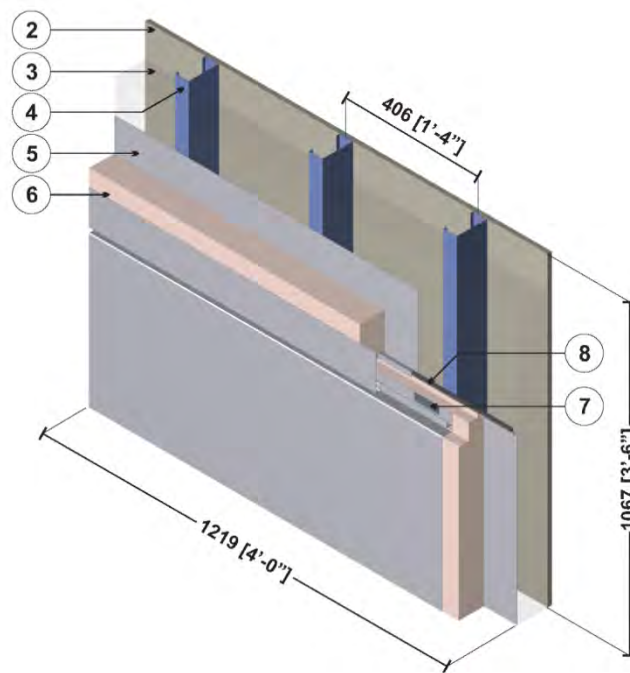

Horizontal Joint

ID	Component	Thickness Inches (mm)	Conductivity Btu·in / ft ² ·hr·°F (W/m K)	Nominal Resistance hr·ft ² ·°F/Btu (m ² K/W)	Density lb/ft ³ (kg/m ³)	Specific Heat Btu/lb·°F (J/kg K)
1	Interior Film ¹	-	-	R-0.7 (0.12 RSI)	-	-
2	Gypsum Board	1/2" (13)	1.1 (0.16)	R-0.5 (0.08 RSI)	50 (800)	0.26 (1090)
3	Air in Stud Cavity	-	-	R-0.9 (0.16 RSI)	0.075 (1.2)	0.24 (1000)
4	3 5/8" x 1 5/8" Steel Studs (16" o.c.)	18 Gauge	430 (62)	-	489 (7830)	0.12 (500)
5	Polyisocyanurate Insulation	3" (76)	0.143 (0.02)	R-21.0 (3.70)	1.8 (28)	0.29 (1220)
6	Steel Facer Skin	24 Gauge	430 (62)	-	489 (7830)	0.12 (500)
7	#14 Steel Fasteners	1/4" (6) Ø	314 (45)	-	489 (7830)	0.12 (500)
8	Sealant	Varies	2.4 (0.35)	-	-	-
9	Exterior Film ¹	-	-	R-0.2 (0.03 RSI)	-	-

¹ Value selected from table 1, p. 26.1 of 2009 ASHRAE Handbook – Fundamentals depending on surface orientation

Detail 6.1.4

Horizontal Insulated Metal Panel – Vertical Gasket Joint with Steel Stud Backup Wall

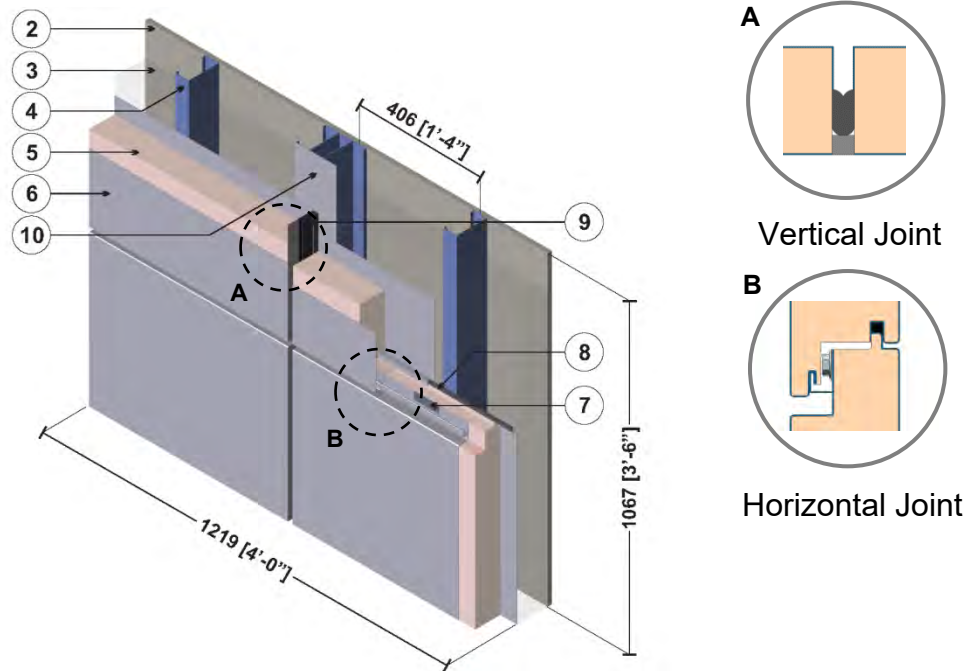

ID	Component	Thickness Inches (mm)	Conductivity Btu·in / ft ² ·hr·°F (W/m K)	Nominal Resistance hr·ft ² ·°F/Btu (m ² K/W)	Density lb/ft ³ (kg/m ³)	Specific Heat Btu/lb·°F (J/kg K)
1	Interior Film ¹	-	-	R-0.7 (0.12 RSI)	-	-
2	Gypsum Board	1/2" (13)	1.1 (0.16)	R-0.5 (0.08 RSI)	50 (800)	0.26 (1090)
3	Air in Stud Cavity	-	-	R-0.9 (0.16 RSI)	0.075 (1.2)	0.24 (1000)
4	3 5/8" x 1 5/8" Steel Studs (16" o.c.)	18 Gauge	430 (62)	-	489 (7830)	0.12 (500)
5	Polyisocyanurate Insulation	3" (76)	0.143 (0.02)	R-21.0 (3.70)	1.8 (28)	0.29 (1220)
6	Steel Facer Skin	24 Gauge	430 (62)	-	489 (7830)	0.12 (500)
7	#14 Steel Fasteners	1/4" (6) Ø	314 (45)	-	489 (7830)	0.12 (500)
8	Sealant	Varies	2.4 (0.35)	-	-	-
9	Gasket	1 1/3" (33)	0.966 (0.14)	-	-	-
10	Steel Plate	20 Gauge	430 (62)	-	489 (7830)	0.12 (500)
11	Exterior Film ¹	-	-	R-0.2 (0.03 RSI)	-	-

¹ Value selected from table 1, p. 26.1 of 2009 ASHRAE Handbook – Fundamentals depending on surface orientation

Detail 6.1.5

Structural Sheet Steel Wall with Cladding Supported by Notched Z-Bar for Baseline System – Clear Wall

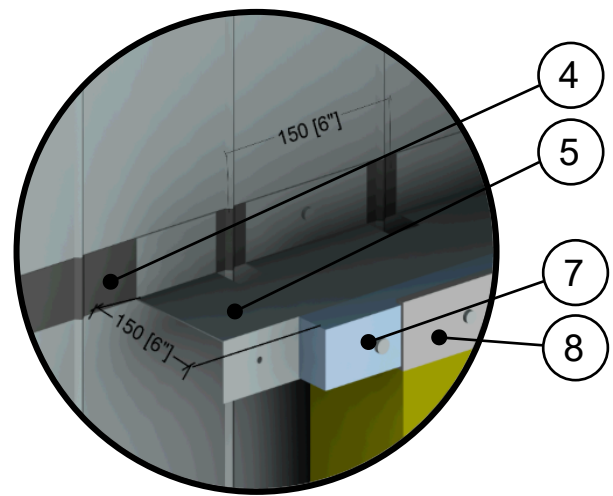
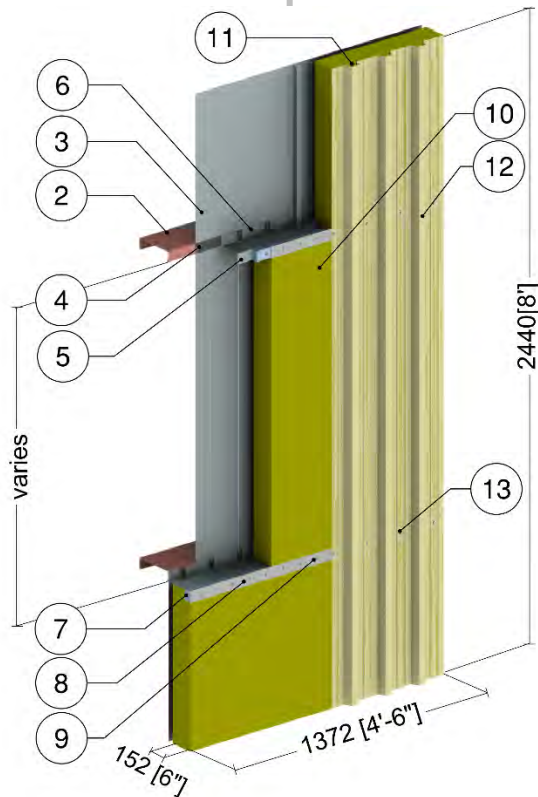

Notched Z-Bar with Thermal Block and U-Bar

ID	Component	Thickness Inches (mm)	Conductivity Btu-in / ft ² ·hr·°F (W/m K)	Nominal Resistance hr·ft ² ·°F/Btu (m ² K/W)	Density lb/ft ³ (kg/m ³)	Specific Heat Btu/lb·°F (J/kg K)
1	Interior Films (left side) ¹	-	-	R-0.7 (0.12 RSI)	-	-
2	8 x 2 Steel Girts @ 48" o.c.	0.10" (2.6)	347 (50)	-	489 (7830)	0.12 (500)
3	Galvanized Steel Liner Panel	24 Gauge	430 (62)	-	489 (7830)	0.12 (500)
4	Thermal Tape	1/8" (3.2)	0.097 (0.014)	-	-	-
5	Galvanized Steel Notched Z-Bar	18 Gauge	430 (62)	-	489 (7830)	0.12 (500)
6	#12 Galvanized Steel Fasteners	0.21" (5) Ø	430 (62)	-	489 (7830)	0.12 (500)
7	Thermal Block Insulation	2" (50)	0.200 (0.029)	R-10 (1.76 RSI)	9.4 (150)	0.23 (1000)
8	Galvanized Steel U-Bar	18 Gauge	430 (62)	-	489 (7830)	0.12 (500)
9	#12 Galvanized Steel Fasteners (7.5" o.c.)	0.21" (5) Ø	430 (62)	-	489 (7830)	0.12 (500)
10	Exterior Mineral Wool Insulation	6" (152)	0.238 (0.034)	R-25 (4.4 RSI)	1.8 (28)	0.29 (1090)
11	Air Gap ²	-	Varies	-	0.075 (1.2)	0.24 (1000)
12	Galvanized Steel Cladding	24 Gauge	430 (62)	-	489 (7830)	0.12 (500)
13	#12 Galvanized Steel Fasteners	0.21" (5) Ø	430 (62)	-	489 (7830)	0.12 (500)
14	Exterior Film (right side) ¹	-	-	R-0.2 (0.03 RSI)	-	-

¹ Value selected from table 1, p. 26.1 of 2009 ASHRAE Handbook – Fundamentals depending on surface orientation

² The thermal conductivity of air spaces was found using ISO 100077-2

Detail 6.1.6

Structural Sheet Steel Wall with Cladding Supported by Intermittent Notched Z-Bar – Clear Wall

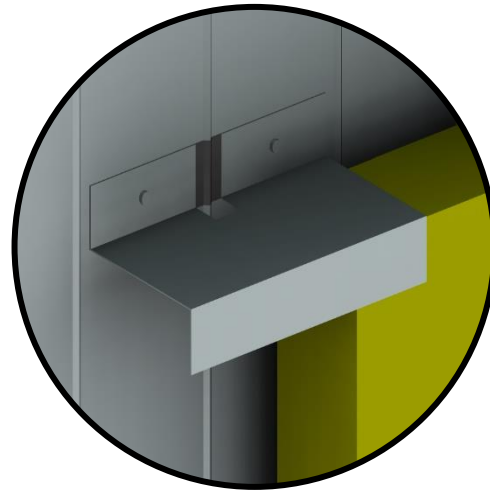
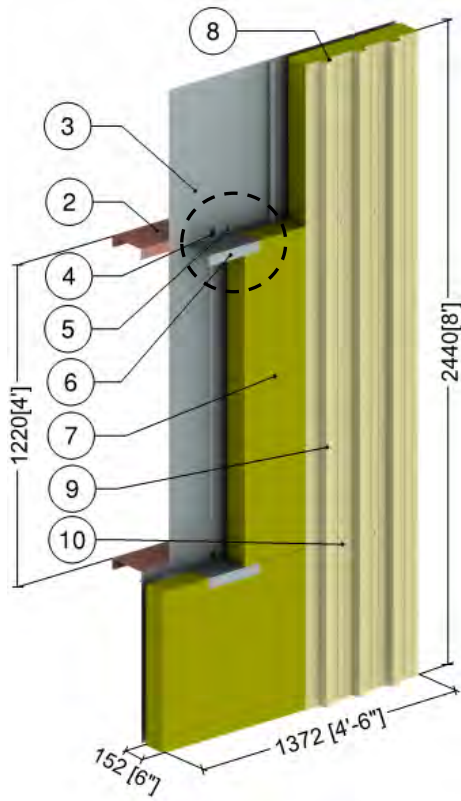

Intermittent Notched Z-Bar

ID	Component	Thickness Inches (mm)	Conductivity Btu-in / ft ² ·hr·°F (W/m K)	Nominal Resistance hr·ft ² ·°F/Btu (m ² K/W)	Density lb/ft ³ (kg/m ³)	Specific Heat Btu/lb·°F (J/kg K)
1	Interior Films (left side) ¹	-	-	R-0.7 (0.12 RSI)	-	-
2	8 x 2 Steel Girts @ 48" o.c.	0.10" (2.6)	347 (50)	-	489 (7830)	0.12 (500)
3	Galvanized Steel Liner Panel	24 Gauge	430 (62)	-	489 (7830)	0.12 (500)
4	Thermal Tape	1/8" (3.2)	0.097 (0.014)	-	-	-
5	#12 Galvanized Steel Fasteners	0.21" (5) Ø	430 (62)	-	489 (7830)	0.12 (500)
6	Galvanized Steel Notched Z-Bar	18 Gauge	430 (62)	-	489 (7830)	0.12 (500)
7	Exterior Mineral Wool Insulation	6" (152)	0.238 (0.034)	R-25 (4.4 RSI)	1.8 (28)	0.29 (1090)
8	Air Gap ²	-	Varies	-	0.075 (1.2)	0.24 (1000)
9	Galvanized Steel Cladding	24 Gauge	430 (62)	-	489 (7830)	0.12 (500)
10	#12 Galvanized Steel Fasteners (7.5" o.c.)	0.21" (5) Ø	430 (62)	-	489 (7830)	0.12 (500)
11	Exterior Film (right side) ¹	-	-	R-0.2 (0.03 RSI)	-	-

¹ Value selected from table 1, p. 26.1 of 2009 ASHRAE Handbook – Fundamentals depending on surface orientation

² The thermal conductivity of air spaces was found using ISO 100077-2

Detail 6.1.7

Structural Sheet Steel Wall with Cladding Supported by Thermal Chairs – Clear Wall

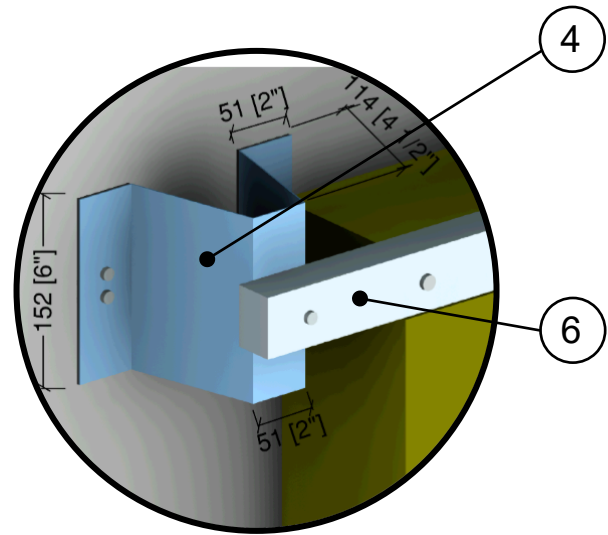
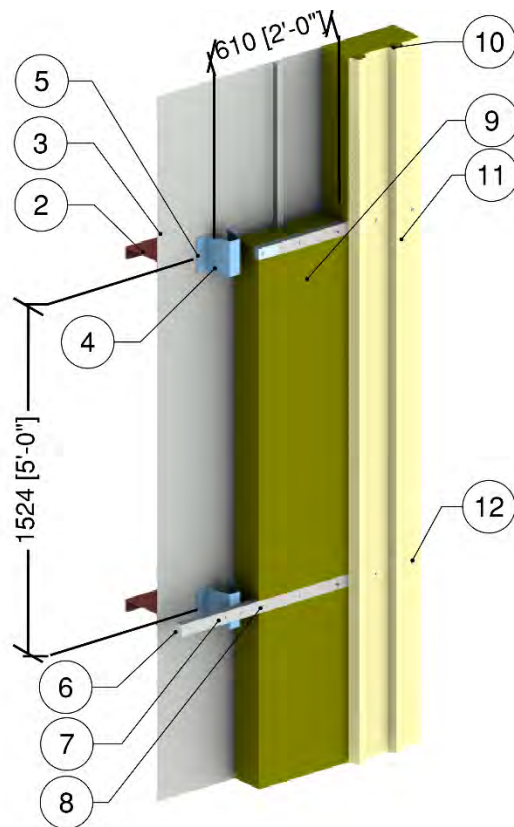

Thermal Chair with Thermal Block and U-Bar

ID	Component	Thickness Inches (mm)	Conductivity Btu-in / ft ² -hr-°F (W/m K)	Nominal Resistance hr-ft ² -°F/Btu (m ² K/W)	Density lb/ft ³ (kg/m ³)	Specific Heat Btu/lb-°F (J/kg K)
1	Interior Films (left side) ¹	-	-	R-0.7 (0.12 RSI)	-	-
2	8 x 2 Steel Girts @ 48" o.c.	0.10" (2.6)	347 (50)	-	489 (7830)	0.12 (500)
3	Galvanized Steel Liner Panel	24 Gauge	430 (62)	-	489 (7830)	0.12 (500)
4	Thermal chairs	18 Gauge	430 (62)	-	-	-
5	#12 Galvanized Steel Fasteners	0.21" (5) Ø	430 (62)	-	489 (7830)	0.12 (500)
6	Thermal Block Insulation	2" (50)	0.200 (0.029)	R-10 (1.76 RSI)	9.4 (150)	0.23 (1000)
7	Galvanized Steel U-Bar	18 Gauge	430 (62)	-	489 (7830)	0.12 (500)
8	#12 Galvanized Steel Fasteners (7.5" o.c.)	0.21" (5) Ø	430 (62)	-	489 (7830)	0.12 (500)
9	Exterior Mineral Wool Insulation	6" (152)	0.238 (0.034)	R-25 (4.4 RSI)	1.8 (28)	0.29 (1090)
10	Air Gap ²	-	Varies	-	0.075 (1.2)	0.24 (1000)
11	Galvanized Steel Cladding	24 Gauge	430 (62)	-	489 (7830)	0.12 (500)
12	#12 Galvanized Steel Fasteners (7.5" o.c.)	0.21" (5) Ø	430 (62)	-	489 (7830)	0.12 (500)
13	Exterior Film (right side) ¹	-	-	R-0.2 (0.03 RSI)	-	-

¹ Value selected from table 1, p. 26.1 of 2009 ASHRAE Handbook – Fundamentals depending on surface orientation

² The thermal conductivity of air spaces was found using ISO 10077-2

Detail 6.1.8

2 Hour Fire Rated Structural Steel Sheet Wall with Cladding Supported by Notched Z-bar with Ceramic Blanket – Clear Wall

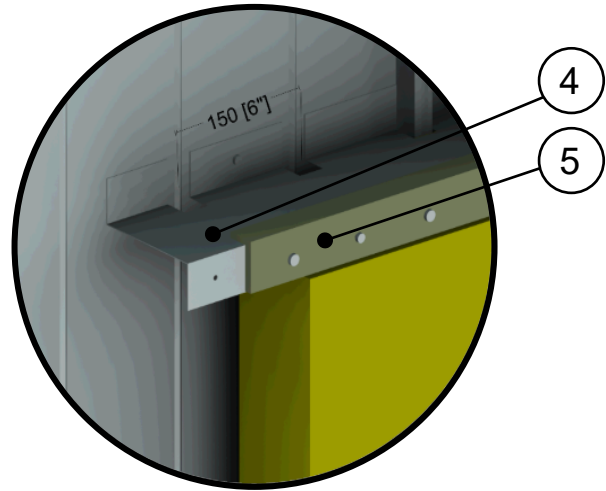
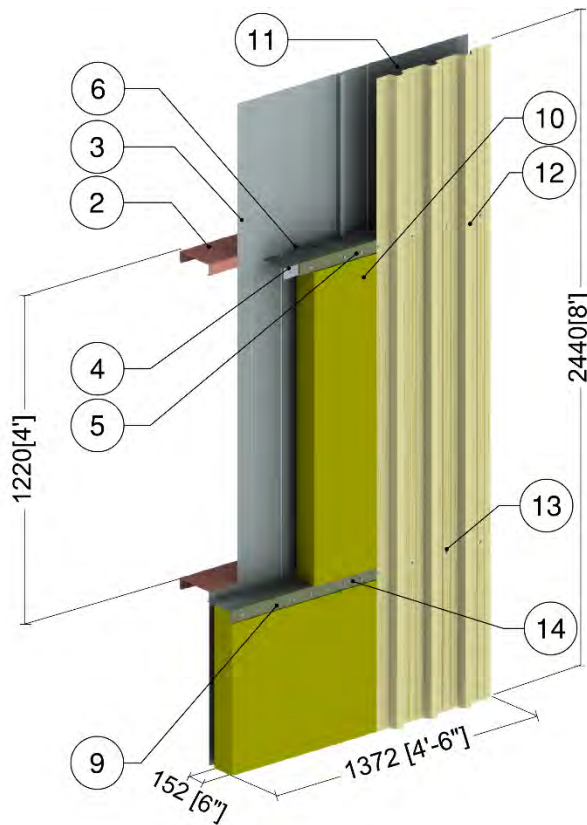

Notched Z-Bar with
Ceramic Blanket

ID	Component	Thickness Inches (mm)	Conductivity Btu-in / ft ² -hr-°F (W/m K)	Nominal Resistance hr-ft ² -°F/Btu (m ² K/W)	Density lb/ft ³ (kg/m ³)	Specific Heat Btu/lb-°F (J/kg K)
1	Interior Films (left side) ¹	-	-	R-0.7 (0.12 RSI)	-	-
2	8 x 2 Steel Girts @ 48" o.c.	0.10" (2.6)	347 (50)	-	489 (7830)	0.12 (500)
3	Galvanized Steel Liner Panel	24 Gauge	430 (62)	-	489 (7830)	0.12 (500)
4	Galvanized Steel Notched Z-Bar	18 Gauge	430 (62)	-	489 (7830)	0.12 (500)
5	Ceramic Fibre strip	-	-	-	-	-
6	#12 Galvanized Steel Fasteners	0.21" (5) Ø	430 (62)	-	489 (7830)	0.12 (500)
7	#12 Galvanized Steel Fasteners	0.21" (5) Ø	430 (62)	-	489 (7830)	0.12 (500)
8	Exterior Mineral Wool Insulation	6" (152)	0.238 (0.034)	R-25 (4.4 RSI)	1.8 (28)	0.29 (1090)
9	Air Gap ²	-	Varies	-	0.075 (1.2)	0.24 (1000)
10	Galvanized Steel Cladding	24 Gauge	430 (62)	-	489 (7830)	0.12 (500)
11	#12 Galvanized Steel Fasteners (7.5" o.c.)	0.21" (5) Ø	430 (62)	-	489 (7830)	0.12 (500)
12	Ceramic Blanket	1/2" (13)	0.62 (0.09)	R-0.8 (0.14)	-	-
13	Exterior Film (right side) ¹	-	-	R-0.2 (0.03 RSI)	-	-

¹ Value selected from table 1, p. 26.1 of 2009 ASHRAE Handbook – Fundamentals depending on surface orientation

² The thermal conductivity of air spaces was found using ISO 100077-2

Detail 6.2.1

Vertical Insulated Metal Panel - Corrugated Slab Intersection with I-beam – Open Web Steel Joist and Support Girt/Hat Track Backup Wall

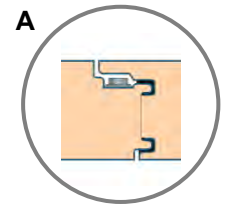
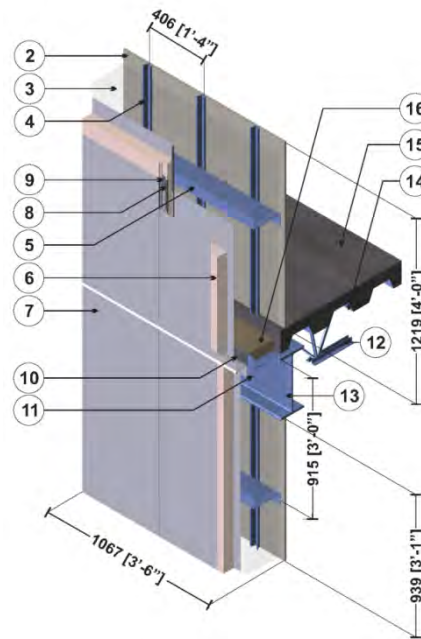

Vertical Joint

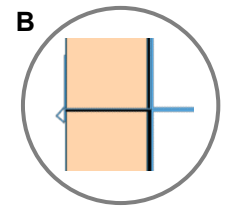

Horizontal Joint

ID	Component	Thickness Inches (mm)	Conductivity Btu-in / ft ² ·hr·°F (W/m K)	Nominal Resistance hr·ft ² ·°F/Btu (m ² K/W)	Density lb/ft ³ (kg/m ³)	Specific Heat Btu/lb·°F (J/kg K)
1	Interior Film ¹	-	-	R-0.6 to R-0.9 (0.11 RSI to 0.16 RSI)	-	-
2	Gypsum Board	1/2" (13)	1.1 (0.16)	R-0.5 (0.08 RSI)	50 (800)	0.26 (1090)
3	Air in Stud Cavity	-	-	R-0.9 (0.16 RSI)	0.075 (1.2)	0.24 (1000)
4	Hat Tracks @ 16" o.c.	18 Gauge	430 (62)	-	489 (7830)	0.12 (500)
5	Z-Girts with 1 1/2" Flange	16 Gauge	430 (62)	-	489 (7830)	0.12 (500)
6	Polyisocyanurate Insulation	3" (76)	0.143 (0.02)	R-21 (3.70)	1.8 (28)	0.29 (1220)
7	Steel Facer Skin	24 gauge	430 (62)	-	489 (7830)	0.12 (500)
8	Sealant	-	2.4 (0.35)	-	-	-
9	#14 Steel Fasteners	1/4" (6) Ø	314 (45)	-	489 (7830)	0.12 (500)
10	Steel Flashing & Trim	18 gauge	430 (62)	-	489 (7830)	0.12 (500)
11	Steel Angle	16 gauge	430 (62)	-	489 (7830)	0.12 (500)
12	Open Web Steel Joist	-	314 (45)	-	489 (7830)	0.12 (500)
13	Steel Beam (W410)	-	314 (45)	-	489 (7830)	0.12 (500)
14	Steel Deck	1/16" (1.6)	314 (45)	-	489 (7830)	0.12 (500)
15	Concrete Topping	6" (152)	6 (0.9)	-	120 (1920)	0.20 (850)
16	Semi-Rigid Insulation	-	0.28 (0.04)	-	4.5 (72)	0.17 (710)
17	Exterior Film ¹	-	-	R-0.2 (0.03 RSI)	-	-

¹ Value selected from table 1, p. 26.1 of 2009 ASHRAE Handbook – Fundamentals depending on surface orientation

Detail 6.2.2

Horizontal Insulated Metal Panel – Corrugated Slab Intersection with I-beam – Open Web Steel Joist and Steel Stud Backup Wall

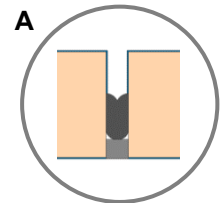
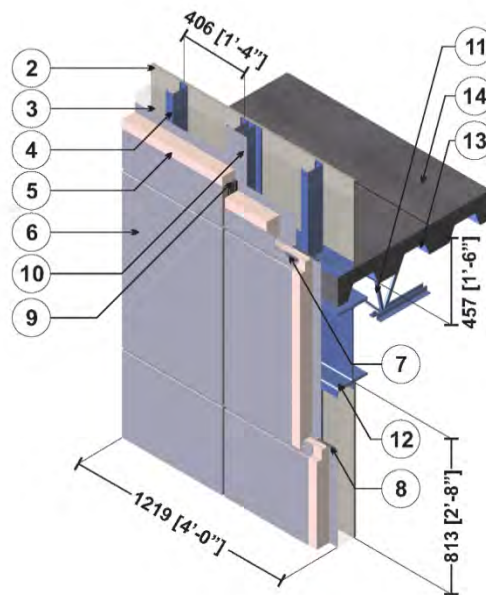

Vertical Joint

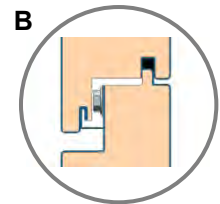

Horizontal Joint

ID	Component	Thickness Inches (mm)	Conductivity Btu·in / ft ² ·hr·°F (W/m K)	Nominal Resistance hr·ft ² ·°F/Btu (m ² K/W)	Density lb/ft ³ (kg/m ³)	Specific Heat Btu/lb·°F (J/kg K)
1	Interior Film ¹	-	-	R-0.6 to R-0.9 (0.11 RSI to 0.16 RSI)	-	-
2	Gypsum Board	1/2" (13)	1.1 (0.16)	R-0.5 (0.08 RSI)	50 (800)	0.26 (1090)
3	Air in Stud Cavity	-	-	R-0.9 (0.16 RSI)	0.075 (1.2)	0.24 (1000)
4	3 5/8" x 1 5/8" Steel Studs (16" o.c.)	18 Gauge	430 (62)	-	489 (7830)	0.12 (500)
5	Polyisocyanurate Insulation	3" (76.2)	0.143 (0.02)	R-21.0 (3.70)	1.8 (28)	0.29 (1220)
6	Steel Facer Skin	24 Gauge	430 (62)	-	489 (7830)	0.12 (500)
7	#14 Steel Fasteners	1/4" (6) Ø	314 (45)	-	489 (7830)	0.12 (500)
8	Sealant	-	2.4 (0.35)	-	-	-
9	Gasket	1 1/3" (33)	0.966 (0.14)	-	-	-
10	Steel Plate	20 Gauge	430 (62)	-	489 (7830)	0.12 (500)
11	Open Web Steel Joist	-	314 (45)	-	489 (7830)	0.12 (500)
12	Steel Beam (W410)	-	314 (45)	-	489 (7830)	0.12 (500)
13	Steel Deck	1/16" (1.6)	314 (45)	-	489 (7830)	0.12 (500)
14	Concrete Topping	6" (152)	6.3 (0.9)	-	120 (1920)	0.20 (850)
15	Exterior Film ¹	-	-	R-0.2 (0.03 RSI)	-	-

¹ Value selected from table 1, p. 26.1 of 2009 ASHRAE Handbook – Fundamentals depending on surface orientation

Detail 6.3.1

Vertical Insulated Metal Panel – Window Glazing Transition with Steel Support Framing

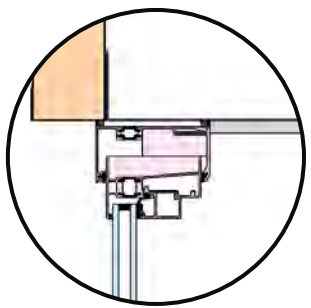
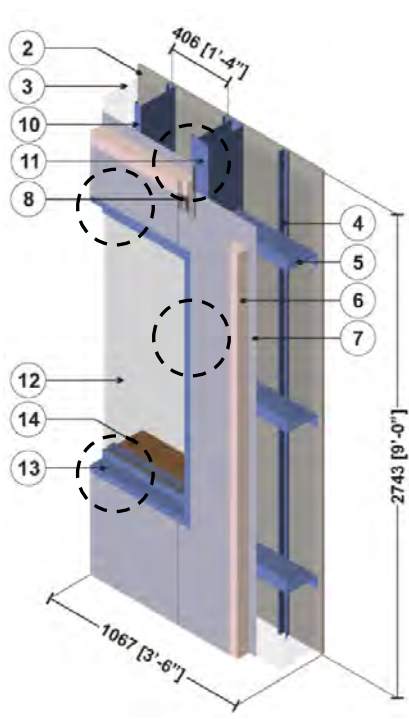

Head Detail

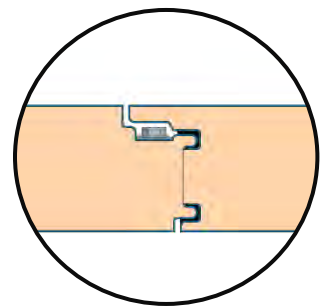

Vertical Joint

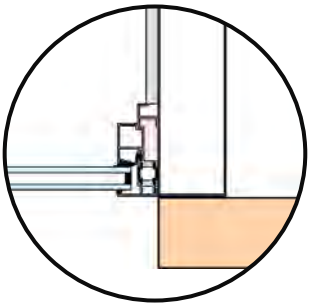

Jamb Detail

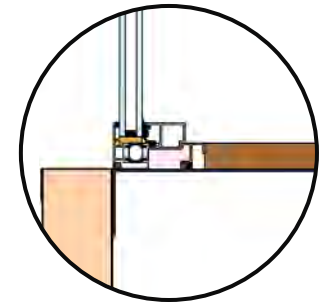

Sill Detail

ID	Component	Thickness Inches (mm)	Conductivity Btu·in / ft ² ·hr·°F (W/m K)	Nominal Resistance hr·ft ² ·°F/Btu (m ² K/W)	Density lb/ft ³ (kg/m ³)	Specific Heat Btu/lb·°F (J/kg K)
1	Interior Film ¹	-	-	R-0.7 (0.12 RSI)	-	-
2	Gypsum Board	1/2" (13)	1.1 (0.16)	R-0.5 (0.08 RSI)	50 (800)	0.26 (1090)
3	Air in Stud Cavity	-	-	R-0.9 (0.16 RSI)	0.075 (1.2)	0.24 (1000)
4	Hat Tracks @ 16" o.c.	18 Gauge	430 (62)	-	489 (7830)	0.12 (500)
5	Z-Girts with 1 1/2" Flange	16 Gauge	430 (62)	-	489 (7830)	0.12 (500)
6	Polyisocyanurate Insulation	3" (76.2)	0.143 (0.02)	R-21.0 (3.70)	1.8 (28)	0.29 (1220)
7	Steel Facer Skin	24 Gauge	430 (62)	-	489 (7830)	0.12 (500)
8	Sealant	-	2.4 (0.35)	-	-	-
9	#14 Steel Fasteners	1/4" (6) Ø	314 (45)	-	489 (7830)	0.12 (500)
10	Steel Studs @ 16" o.c. with Track	18 gauge	430 (62)	-	489 (7830)	0.12 (500)
11	Steel Support Post	1/8" (3.2)	314 (45)	-	489 (7830)	0.12 (500)
12	5' (1.5m) High aluminum window: double glazed & thermally broken ²					
13	Window Trim and Sill Flashing	18 Gauge	430 (62)	-	489 (7830)	0.12 (500)
14	Wood Sill	5/8" (16)	0.6 (0.09)	-	27.8 (445)	0.45 (1880)
15	Exterior Film ¹	-	-	R-0.2 (0.03 RSI)	-	-

¹ Value selected from table 1, p. 26.1 of 2009 ASHRAE Handbook – Fundamentals depending on surface orientation & surface emissivity. Window values supplemented by ISO 1007-2, Annex B.

² The thermal conductivity of air spaces within window framing was found using ISO 10077-2



Detail 6.3.2

Horizontal Insulated Metal Panel – Window Glazing Transition with Steel Support Framing

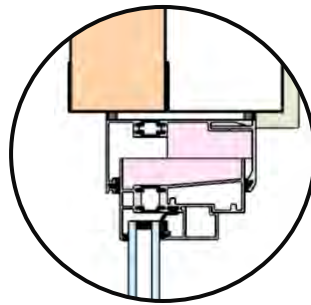
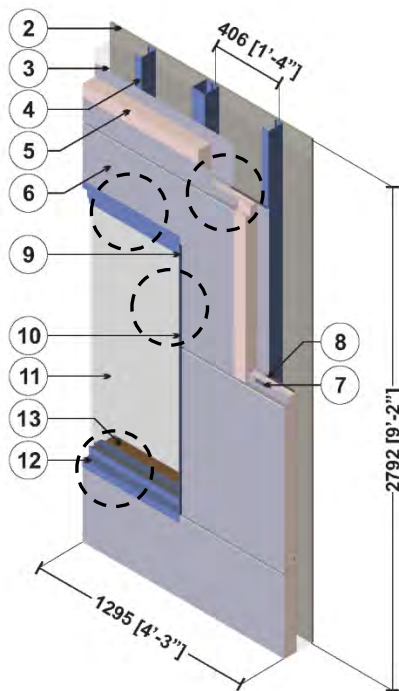

Head Detail

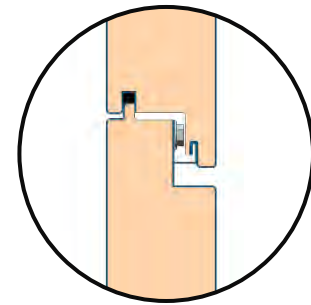

Horizontal Joint

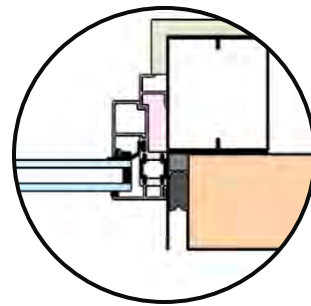

Jamb Detail

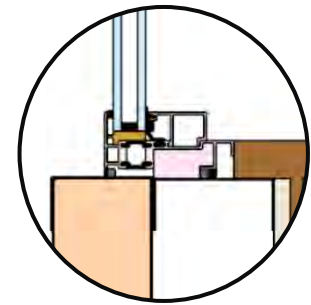

Sill Detail

ID	Component	Thickness Inches (mm)	Conductivity Btu-in / ft ² ·hr·°F (W/m K)	Nominal Resistance hr·ft ² ·°F/Btu (m ² K/W)	Density lb/ft ³ (kg/m ³)	Specific Heat Btu/lb·°F (J/kg K)
1	Interior Film ¹	-	-	R-0.7 (0.12 RSI)	-	-
2	Gypsum Board	1/2" (13)	1.1 (0.16)	R-0.5 (0.08 RSI)	50 (800)	0.26 (1090)
3	Air in Stud Cavity	-	-	R-0.9 (0.16 RSI)	0.075 (1.2)	0.24 (1000)
4	3 5/8" x 1 5/8" Steel Studs (16" o.c.) with Track	18 Gauge	430 (62)	-	489 (7830)	0.12 (500)
5	Polyisocyanurate Insulation	3" (76)	0.143 (0.02)	R-21.0 (3.70)	1.8 (28)	0.29 (1220)
6	Steel Facer Skin	24 Gauge	430 (62)	-	489 (7830)	0.12 (500)
7	#14 Steel Fasteners	1/4" (6) Ø	314 (45)	-	489 (7830)	0.12 (500)
8	Sealant	-	2.4 (0.35)	-	-	-
9	Gasket	-	0.966 (0.14)	-	-	-
10	Steel Plate	20 Gauge	430 (62)	-	489 (7830)	0.12 (500)
11	5' (1.5m) High aluminum window: double glazed & thermally broken ²					
12	Steel Window Trim and Sill Flashing	18 Gauge	430 (62)	-	489 (7830)	0.12 (500)
13	Wood Sill	5/8" (16)	0.69 (0.10)	-	27.8 (445)	0.45 (1880)
14	Exterior Film ¹	-	-	R-0.2 (0.03 RSI)	-	-

¹ Value selected from table 1, p. 26.1 of 2009 ASHRAE Handbook – Fundamentals depending on surface orientation & surface emissivity. Window values supplemented by ISO 1007-2, Annex B.

² The thermal conductivity of air spaces within curtain wall framing was found using ISO 10077-2

Detail 6.4.1

Vertical Insulated Metal Panel – Steel Roof Deck with Open Web Steel Joist & Parapet Intersection

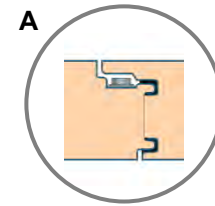
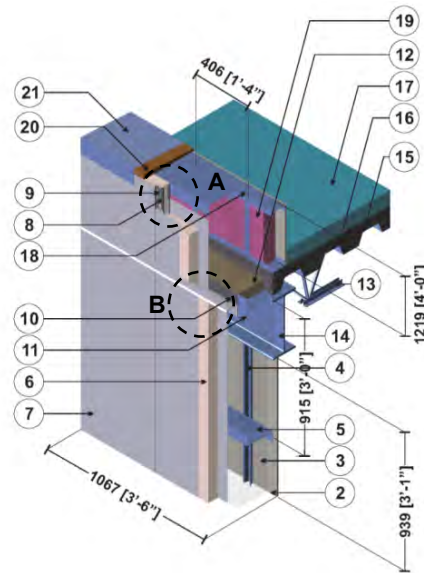

Vertical Joint

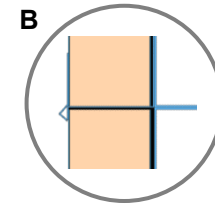

Horizontal Joint

ID	Component	Thickness Inches (mm)	Conductivity Btu-in / ft ² ·hr·°F (W/m K)	Nominal Resistance hr·ft ² ·°F/Btu (m ² K/W)	Density lb/ft ³ (kg/m ³)	Specific Heat Btu/lb·°F (J/kg K)
1	Interior Film ¹	-	-	R-0.6 to R-0.7 (0.11 RSI to 0.12 RSI)	-	-
2	Gypsum Board	1/2" (13)	1.1 (0.16)	R-0.5 (0.08 RSI)	50 (800)	0.26 (1090)
3	Air in Cavity	-	-	R-0.9 (0.16 RSI)	0.075 (1.2)	0.24 (1000)
4	Hat Tracks @ 16" o.c.	18 Gauge	430 (62)	-	489 (7830)	0.12 (500)
5	Z-Girts with 1 1/2" Flange	16 Gauge	430 (62)	-	489 (7830)	0.12 (500)
6	Polyisocyanurate Insulation	3" (76)	0.143 (0.02)	R-21.0 (3.70)	1.8 (28)	0.29 (1220)
7	Steel Facer Skin	24 Gauge	430 (62)	-	489 (7830)	0.12 (500)
8	Sealant	-	2.4 (0.35)	-	-	-
9	#14 Steel Fasteners	1/4" (6) Ø	314 (45)	-	489 (7830)	0.12 (500)
10	Steel Flashing & Trim	18 Gauge	430 (62)	-	489 (7830)	0.12 (500)
11	Steel Angle	16 Gauge	430 (62)	-	489 (7830)	0.12 (500)
12	Semi-Rigid Insulation	-	0.28 (0.04)	-	4.5 (72)	0.17 (710)
13	Open Web Steel Joist	-	314 (45)	-	489 (7830)	0.12 (500)
14	Steel Beam (W410)	-	314 (45)	-	489 (7830)	0.12 (500)
15	Steel Deck	1/16" (2)	314 (45)	-	489 (7830)	0.12 (500)
16	Concrete Topping	6" (152)	6.3 (0.9)	-	120 (1920)	0.20 (850)
17	Roof Insulation	4" (102)	-	R-20 (3.5 RSI)	1.8 (28)	0.29 (1220)
18	3 5/8" x 1 5/8" Steel Studs with Track	18 Gauge	430 (62)	-	489 (7830)	0.12 (500)
19	Parapet Insulation	-	0.29 (0.042)	R-12 (2.1 RSI)	0.9 (14)	0.17 (710)
20	Wood Block	5/8" (16)	0.69 (0.10)	-	27.8 (445)	0.45 (1880)
21	Flashing & roof finish materials are incorporated into exterior heat transfer coefficient.					
22	Exterior Film ¹	-	-	R-0.2 (0.03 RSI)	-	-

¹ Value selected from table 1, p. 26.1 of 2009 ASHRAE Handbook – Fundamentals depending on surface orientation

Detail 6.4.2

Horizontal Insulated Metal Panel – Steel Roof Deck with Open Web Steel Joist & Parapet Intersection

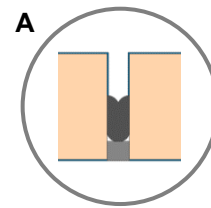
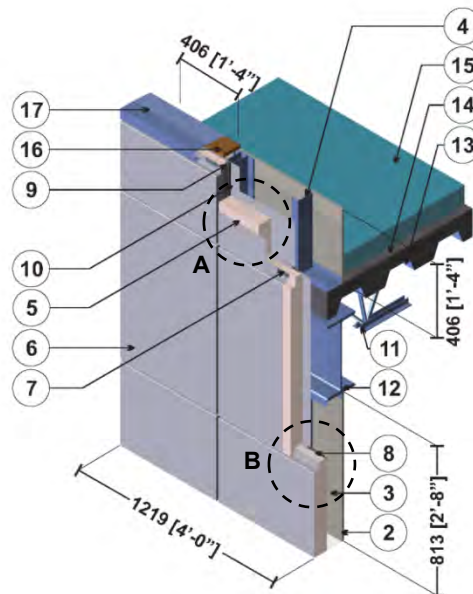

Vertical Joint

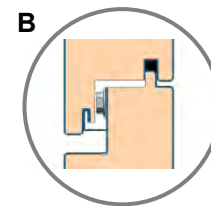

Horizontal Joint

ID	Component	Thickness Inches (mm)	Conductivity Btu·in / ft ² ·hr·°F (W/m K)	Nominal Resistance hr·ft ² ·°F/Btu (m ² K/W)	Density lb/ft ³ (kg/m ³)	Specific Heat Btu/lb·°F (J/kg K)
1	Interior Film ¹	-	-	R-0.6 to R-0.7 (0.11 RSI to 0.12 RSI)	-	-
2	Gypsum Board	1/2" (13)	1.1 (0.16)	R-0.5 (0.08 RSI)	50 (800)	0.26 (1090)
3	Air in Cavity	-	-	R-0.9 (0.16 RSI)	0.075 (1.2)	0.24 (1000)
4	3 5/8" x 1 5/8" Steel Studs (16" o.c.) with Track	18 Gauge	430 (62)	-	489 (7830)	0.12 (500)
5	Polyisocyanurate Insulation	3" (76)	0.143 (0.02)	R-21.0 (3.70)	1.8 (28)	0.29 (1220)
6	Steel Facer Skin	24 Gauge	430 (62)	-	489 (7830)	0.12 (500)
7	#14 Steel Fasteners	1/4" (6) Ø	314 (45)	-	489 (7830)	0.12 (500)
8	Sealant	-	2.4 (0.35)	-	-	-
9	Gasket	-	0.966 (0.14)	-	-	-
10	Steel Plate	20 Gauge	430 (62)	-	489 (7830)	0.12 (500)
11	Open Web Steel Joist	-	314 (45)	-	489 (7830)	0.12 (500)
12	Steel Beam (W410)	-	314 (45)	-	489 (7830)	0.12 (500)
13	Steel Deck	1/16" (1.6)	314 (45)	-	489 (7830)	0.12 (500)
14	Concrete Topping	6" (152)	6.3 (0.9)	-	120 (1920)	0.20 (850)
15	Roof Insulation	4" (102)	-	R-20 (3.5 RSI)	1.8 (28)	0.29 (1220)
16	Wood Block	5/8" (16)	0.69 (0.10)	-	27.8 (445)	0.45 (1880)
17	Flashing & roof finish materials are incorporated into exterior heat transfer coefficient.					
18	Exterior Film ¹	-	-	R-0.2 (0.03 RSI)	-	-

¹ Value selected from table 1, p. 26.1 of 2009 ASHRAE Handbook – Fundamentals depending on surface orientation

Detail 6.5.1

Vertical Insulated Metal Panel – Corner Intersection with Post and Support Girt/Hat Track Backup Wall

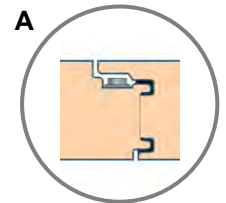
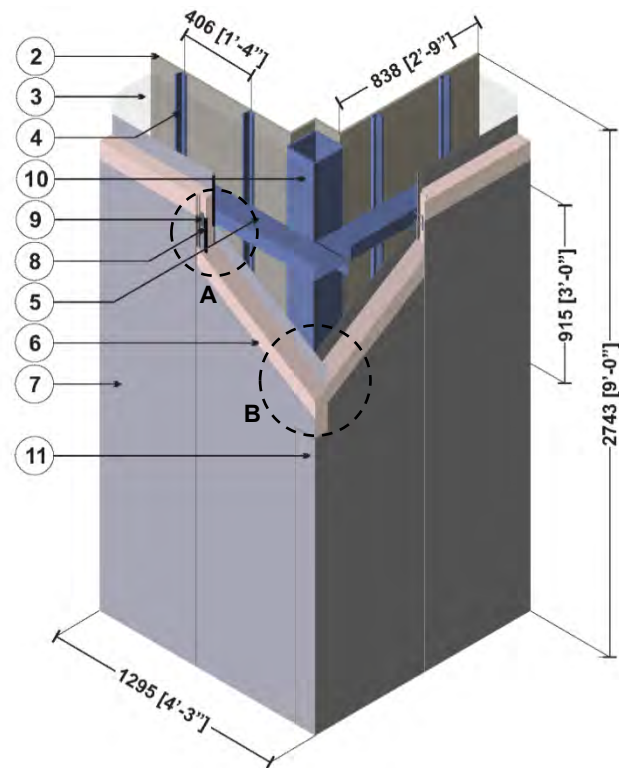

Vertical Joint

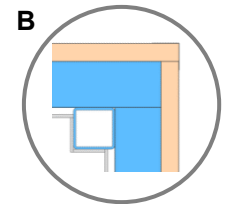

Corner Plan Detail

ID	Component	Thickness Inches (mm)	Conductivity Btu-in / ft ² -hr-°F (W/m K)	Nominal Resistance hr-ft ² -°F/Btu (m ² K/W)	Density lb/ft ³ (kg/m ³)	Specific Heat Btu/lb-°F (J/kg K)
1	Interior Film ¹	-	-	R-0.7 (0.12 RSI)	-	-
2	Gypsum Board	1/2" (13)	1.1 (0.16)	R-0.5 (0.08 RSI)	50 (800)	0.26 (1090)
3	Air in Cavity	-	-	R-0.9 (0.16 RSI)	0.075 (1.2)	0.24 (1000)
4	Hat Tracks @ 16" o.c.	18 Gauge	430 (62)	-	489 (7830)	0.12 (500)
5	Z-Girts with 1 1/2" Flange	16 Gauge	430 (62)	-	489 (7830)	0.12 (500)
6	Polyisocyanurate Insulation	3" (76)	0.143 (0.02)	R-21.0 (3.70)	1.8 (28)	0.29 (1220)
7	Steel Facer Skin	24 Gauge	430 (62)	-	489 (7830)	0.12 (500)
8	Sealant	-	2.4 (0.35)	-	-	-
9	#14 Steel Fasteners	1/4" (6) Ø	314 (45)	-	489 (7830)	0.12 (500)
10	HSS Steel Post	1/8" (3)	314 (45)	-	489 (7830)	0.12 (500)
11	Steel Corner Trim	18 Gauge	430 (62)	-	489 (7830)	0.12 (500)
12	Exterior Film ¹	-	-	R-0.7 (0.12 RSI)	-	-

¹ Value selected from table 1, p. 26.1 of 2009 ASHRAE Handbook – Fundamentals depending on surface orientation

Detail 6.5.2

Horizontal Insulated Metal Panel – Corner Intersection with Post and Steel Stud Backup Wall

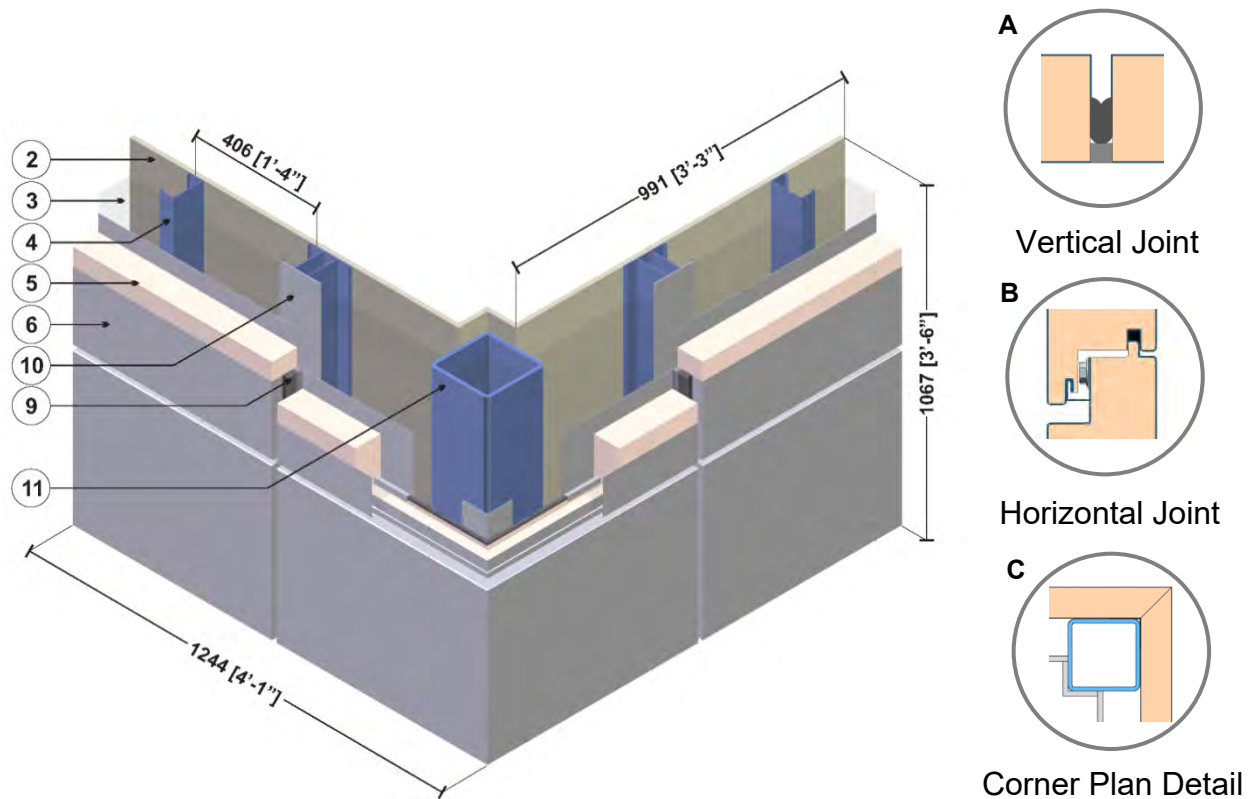

ID	Component	Thickness Inches (mm)	Conductivity Btu-in / ft ² -hr-°F (W/m K)	Nominal Resistance hr-ft ² -°F/Btu (m ² K/W)	Density lb/ft ³ (kg/m ³)	Specific Heat Btu/lb-°F (J/kg K)
1	Interior Film ¹	-	-	R-0.7 (0.12 RSI)	-	-
2	Gypsum Board	1/2" (13)	1.1 (0.16)	R-0.5 (0.08 RSI)	50 (800)	0.26 (1090)
3	Air in Cavity	-	-	R-0.9 (0.16 RSI)	0.075 (1.2)	0.24 (1000)
4	3 5/8" x 1 5/8" Steel Studs (16" o.c.)	18 Gauge	430 (62)	-	489 (7830)	0.12 (500)
5	Polyisocyanurate Insulation	3" (76)	0.143 (0.02)	R-21.0 (3.70)	1.8 (28)	0.29 (1220)
6	Steel Facer Skin	24 Gauge	430 (62)	-	489 (7830)	0.12 (500)
7	#14 Steel Fasteners	1/4" (6) Ø	314 (45)	-	489 (7830)	0.12 (500)
8	Sealant	-	2.4 (0.35)	-	-	-
9	Gasket	-	0.966 (0.14)	-	-	-
10	Steel Plate	20 Gauge	430 (62)	-	489 (7830)	0.12 (500)
11	HSS Steel Post	1/8" (3)	314 (45)	-	489 (7830)	0.12 (500)
12	Exterior Film ¹	-	-	R-0.7 (0.12 RSI)	-	-

¹ Value selected from table 1, p. 26.1 of 2009 ASHRAE Handbook – Fundamentals depending on surface orientation

7.0 Concrete and Mass Masonry Construction

Detail 7.1.1	A.7.1
Exterior Insulated Concrete Drained EIFS Wall Assembly – Clear Wall	
Detail 7.1.2	A.7.2
Exterior Insulated Concrete Mass Wall Assembly with 1/4 inch (6 mm) Stainless Steel Brackets Supporting 1-1/4” Stone Panels – Clear Wall	
Detail 7.1.3	A.7.3
Exterior Insulated Concrete Block Wall with Thermally Broken ISO Clip System with Horizontal Sub-Girt Supporting Cladding – Clear Wall	
Detail 7.1.4	A.7.4
Exterior Insulated Concrete Assembly with Nvelope – NV1 Clip System Supporting Cladding – Clear Wall	
Detail 7.1.5	A.7.5
Exterior Insulated Concrete Block Wall Assembly with Nvelope – NV1 Clip System Supporting Cladding – Clear Wall	
Detail 7.1.6	A.7.6
Exterior Insulated Concrete Mass Wall Assembly with Hohmann & Barnard Masonry Zinc 2-Seal Anchor Supporting Brick Veneer – Clear Wall	
Detail 7.1.7	A.7.7
Exterior Insulated Concrete Mass Wall Assembly with Hohmann & Barnard Masonry Stainless Steel 2-Seal Thermal Wing Nut Anchor Supporting Brick Veneer – Clear Wall	
Detail 7.1.8	A.7.8
Precast Sandwich Panel Wall Assembly with Concrete Panel Joints – Clear Wall	
Detail 7.1.9	A.7.9
Precast Sandwich Panel Wall Assembly with Tigerloc Thermally Broken Panel Joints – Clear Wall	
Detail 7.1.10	A.7.10
Precast Concrete Sandwich Panel Wall Assembly with FRP Connectors – Clear Wall	
Detail 7.1.11	A.7.11
Exterior Insulated Concrete Block Wall with Armadillo FRR Horizontal Z-Girts Supporting Cladding – Clear Wall	
Detail 7.1.12	A.7.12
Exterior Insulated Concrete Block Wall with Vertical Clips Supporting Cladding – Clear Wall	
Detail 7.1.13	A.7.13
Exterior Insulated Concrete Block Wall Assembly with Brick Ties Supporting Brick Veneer – Clear Wall	
Detail 7.1.14	A.7.14

Interior Insulated Concrete Mass Wall with 1 5/8" Steel Stud (16" o.c.) Supporting Interior Finish Wall Assembly – Clear Wall	
Detail 7.1.15	A.7.15
Precast Sandwich Panel Wall Assembly with Steel Connectors and 3 5/8" x 1 5/8" Steel Stud (16" o.c.) – Clear Wall	
Detail 7.1.16	A.7.16
Exterior Insulated Concrete Mass Wall Assembly with 3/8 inch (9.5 mm Stainless Steel Brackets Supporting 3" Stone Panels – Clear Wall	
Detail 7.1.17	A.7.17
Exterior Insulated Concrete Block Wall Assembly with SOPREMA SOPRA-XPS 20 and ACS-S Thermal Clip (16" o.c. Horizontal) Supporting Metal Cladding - Clear Wall	
Detail 7.1.18	A.7.18
Exterior Insulated Concrete Block Wall Assembly with SOPREMA SOPRA-XPS 20 and ACS-S Thermal Clip (24" o.c. Horizontal) Supporting Metal Cladding - Clear Wall	
Detail 7.1.19	A.7.19
Exterior Insulated Concrete Block Wall Assembly with SOPREMA SOPRA-SPF 202 and ACS-S Thermal Clip (16" o.c. Horizontal) Supporting Metal Cladding - Clear Wall	
Detail 7.1.20	A.7.20
Exterior Insulated Concrete Block Wall Assembly with SOPREMA SOPRA-SPF 202 and ACS-S Thermal Clip (24" o.c. Horizontal) Supporting Metal Cladding - Clear Wall	
Detail 7.1.21	A.7.21
Exterior Insulated Concrete Block Wall Assembly with SOPREMA SOPRA-ISO V ALU and ACS-S Thermal Clip (16" o.c. Horizontal) Supporting Metal Cladding - Clear Wall	
Detail 7.1.22	A.7.22
Exterior Insulated Concrete Block Wall Assembly with SOPREMA SOPRA-ISO V ALU and ACS-S Thermal Clip (24" o.c. Horizontal) Supporting Metal Cladding - Clear Wall	
Detail 7.1.23	A.7.23
Exterior Insulated Concrete Block Wall Assembly with Mineral Wool and ACS-S Thermal Clip (16" o.c. Horizontal) Supporting Metal Cladding - Clear Wall	
Detail 7.1.24	A.7.24
Exterior Insulated Concrete Block Wall Assembly with Mineral Wool and ACS-S Thermal Clip (24" o.c. Horizontal) Supporting Metal Cladding - Clear Wall	
Detail 7.1.25	A.7.25

Exterior Insulated Concrete Block Wall Assembly with Protected SOPREMA SOPRA-ISO V ALU and ACS-S Thermal Clip (16" o.c. Horizontal) Supporting Metal Cladding - Clear Wall	
Detail 7.1.26	A.7.26
Exterior Insulated Concrete Block Wall Assembly with Protected SOPREMA SOPRA-ISO V ALU and ACS-S Thermal Clip (24" o.c. Horizontal) Supporting Metal Cladding - Clear Wall	
Detail 7.1.27	A.7.27
Exterior Insulated Concrete Mass Wall with 1 5/8" x 1 5/8" Steel Stud (16" o.c.) and Thermally Isolated Vertical Brackets and Rail System (24" o.c.) Supporting Metal Cladding – Clear Wall	
Detail 7.2.1	A.7.28
Exterior Insulated Concrete Drained EIFS Wall Assembly – Intermediate Floor Intersection	
Detail 7.2.2	A.7.29
Interior Insulated Concrete Mass Wall with 1 5/8" Steel Stud (16" o.c.) Supporting Interior Finish – Non-Insulated Interior Wall and Non-insulated Intermediate Floor Intersection	
Detail 7.2.3	A.7.30
Interior Insulated Concrete Mass Wall with 1 5/8" Steel Stud (16" o.c.) Supporting Interior Finish – Insulated Interior Wall and Non-insulated Intermediate Floor Intersection	
Detail 7.2.4	A.7.31
Interior Insulated Concrete Mass Wall with 3 5/8" x 1 5/8" Steel Studs (16" o.c.) Supporting Interior Finish – Interior Insulated Wall and Non-Insulated Partition Wall Intersection	
Detail 7.2.5	A.7.32
Interior Insulated Concrete Mass Wall with 1 5/8" x 1 5/8" Steel Studs (16" o.c.) Supporting Interior Finish – Continuous Concrete Intermediate Floor Intersection	
Detail 7.2.6	A.7.33
Precast Wall Assembly with 3 5/8" x 1 5/8" Steel Stud (16" o.c.) and Insulation in Stud Cavity – Intermediate Floor Intersection	
Detail 7.2.7	A.7.34
Precast Wall Assembly with 3 5/8" x 1 5/8" Steel Stud (16" o.c.) and Rigid Insulation Outboard of Studs – Intermediate Floor Intersection	
Detail 7.2.8	A.7.35
Precast Sandwich Panel Wall Assembly with 3 5/8" x 1 5/8" Steel Stud (16" o.c.) – Intermediate Floor Intersection	
Detail 7.2.9	A.7.36
Precast Sandwich Panel Wall Assembly with Concrete at Panel Perimeter and Steel Connectors at 24" o.c. – Intermediate Floor Intersection	

Detail 7.2.10	A.7.37
Precast Sandwich Panel Wall Assembly with Steel Connectors at 16" o.c. – Intermediate Floor Intersection	
Detail 7.2.11	A.7.38
Precast Sandwich Panel Wall Assembly with Steel Connectors at 36" o.c. – Intermediate Floor Intersection	
Detail 7.2.12	A.7.39
Precast Sandwich Panel Wall Assembly with Steel Connectors at 48" o.c. – Intermediate Floor Intersection	
Detail 7.2.13	A.7.40
Precast Sandwich Panel Wall Assembly with Fiber-Reinforced Composite Connections at 16" o.c. – Intermediate Floor Intersection	
Detail 7.2.14	A.7.41
Exterior Insulated Concrete Block Wall Assembly with Shelf Angle & Brick Ties Supporting Brick Veneer – Intermediate Floor Intersection	
Detail 7.2.15	A.7.42
Exterior Insulated Concrete Block Wall Assembly with Stand-Off Shelf Angle & Brick Ties Supporting Brick Veneer – Intermediate Floor Intersection	
Detail 7.2.16	A.7.43
Exterior Insulated Concrete Block Wall Assembly with Masonry Ties Supporting Brick Veneer – Intermediate Floor Intersection at Balcony	
Detail 7.2.17	A.7.44
Exterior Insulated Concrete Block Wall Assembly with Masonry Ties Supporting Brick Veneer – Angle Supported Slab & Intermediate Floor Intersection	
Detail 7.2.18	A.7.45
Exterior Insulated Concrete Block Wall Assembly with Masonry Ties Supporting Brick Veneer – Intermediate Floor Intersection at Balcony	
Detail 7.2.19	A.7.46
Exterior Insulated Concrete Block Wall Assembly with Thermally Broken Shelf Angle & Brick Ties Supporting Brick Veneer – Slab Intersection	
Detail 7.2.20	A.7.47
Interior Insulated Concrete Mass Wall with 1 5/8" x 1 5/8" Steel Studs (16" o.c.) Supporting Interior Finish – Isokorb Rutherma DF Thermally Broken Concrete Intermediate Floor Intersection	
Detail 7.2.21	A.7.48
Highly Insulated Precast Concrete Sandwich Panel Wall Assembly – Intermediate Floor Intersection with Inner Wythe Supported by Concrete Floor	
Detail 7.2.22	A.7.49

Owens Corning Exterior Insulated Concrete Block Wall Assembly with Shelf Angle and Heckmann Pos-I-Tie Veneer Anchoring System Supporting Brick Veneer – Intermediate Floor Intersection	
Detail 7.2.23	A.7.50
Owens Corning Exterior Insulated Concrete Block Wall Assembly with Stainless Steel Stand-off Shelf Angle and Heckmann Pos-I-Tie Veneer Anchoring System Supporting Brick Veneer – Intermediate Floor Intersection	
Detail 7.2.24	A.7.51
Exterior Insulated Concrete Mass Wall with 1 5/8" x 1 5/8" Steel Stud (16" o.c.) and Thermally Isolated Vertical Brackets and Rail System (24" o.c.) Supporting Metal Cladding – Intermediate Floor Intersection	
Detail 7.2.25	A.7.52
Highly Insulated Precast Concrete Sandwich Panel Wall Assembly – Intermediate Floor Intersection with Inner Wythe Supported by Concrete Floor	
Detail 7.3.1	A.7.53
Exterior Insulated Concrete Drained EIFS Wall Assembly – Window and Intermediate Floor Intersection	
Detail 7.3.2	A.7.54
Interior Insulated Concrete Mass Wall with 1 5/8" x 1 5/8" Steel Studs (16" o.c.) Supporting Interior Finish – Window & Intermediate Floor Intersection	
Detail 7.3.3	A.7.55
Interior Insulated Concrete Mass Wall with 1 5/8" x 1 5/8" Steel Studs (16" o.c.) Supporting Interior Finish – Window & Intermediate Floor Intersection with Project Slab	
Detail 7.3.4	A.7.56
Precast Sandwich Panel Wall Assembly with Concrete at Panel Perimeter and Steel Connectors at 24" (o.c.) – Window Intersection	
Detail 7.3.5	A.7.57
Precast Sandwich Panel Wall Assembly with Steel Connectors at 24" (o.c.), and 3 5/8" Steel Stud (16" o.c.) – Window Intersection	
Detail 7.3.6	A.7.58
Exterior Insulated Concrete Drained EIFS Wall Assembly – Window with Aerogel and Intermediate Floor Intersection	
Detail 7.3.7	A.7.59
Interior Insulated Concrete Block or Concrete Wall Assembly with Brick Cladding – Window Intersection	
Detail 7.3.8	A.7.60
Interior Insulated Concrete Block or Concrete Wall Assembly with Brick Cladding – Window Intersection Aligned with Insulation	
<i>Detail referenced from work done by Passive House Academy</i>	

Detail 7.3.9	A.7.61
Interior Insulated Concrete Mass Wall with 1 5/8" x 1 5/8" Steel Studs (16" o.c.) Supporting Interior Finish – Window & Projected Slab Intersection with Plywood and Insulation Liner	
Detail 7.3.10	A.7.62
Interior Insulated Concrete Mass Wall with 1 5/8" x 1 5/8" Steel Studs (16" o.c.) Supporting Interior Finish – Window & Projected Slab Intersection with Wall Insulation Wrapped into Opening	
Detail 7.3.11	A.7.63
Interior Insulated Concrete Mass Wall with 1 5/8" x 1 5/8" Steel Studs (16" o.c.) Supporting Interior Finish – Window & Projected Slab Intersection – Plywood Liner and Glazing Aligned with Wall Insulation	
Detail 7.3.12	A.7.64
Exterior Insulated Concrete Mass Wall with 1 5/8" x 1 5/8" Steel Stud (16" o.c.) and Thermally Isolated Vertical Brackets and Rail System (24" o.c.) Supporting Metal Cladding – Triple Glazed Aluminum Window & Intermediate Floor Intersection with Window Thermal Break Positioned in Concrete Opening	
Detail 7.3.13	A.7.65
Exterior Insulated Concrete Mass Wall with 1 5/8" x 1 5/8" Steel Stud (16" o.c.) and Thermally Isolated Vertical Brackets and Rail System (24" o.c.) Supporting Metal Cladding – Triple Glazed Aluminum Curtain Wall & Intermediate Floor Intersection with Window Thermal Break Positioned in the Exterior Insulation	
Detail 7.3.14	A.7.66
Owens Corning Exterior Insulated Concrete Block Wall Assembly with Heckmann Pos-I-Tie Veneer Anchoring System Supporting Brick Veneer with Insulation Interrupted at Window Perimeter – Double Glazed Aluminum Window and Intermediate Floor Intersection	
Detail 7.3.15	A.7.67
Owens Corning Exterior Insulated Concrete Block Wall Assembly with Heckmann Pos-I-Tie Veneer Anchoring System Supporting Brick Veneer with Reduced Insulation at Jambes – Triple Glazed Aluminum High Performance Window and Intermediate Floor Intersection	
Detail 7.3.16	A.7.68
Interior Insulated Multi-Wythe Brick Masonry Wall with 1 5/8" x 1 5/8" Steel Studs (16" o.c.) Supporting Interior Finish – Wood Window Intersection with Un-Insulated Window Perimeter	
Detail 7.3.17	A.7.69
Interior Insulated Multi-Wythe Brick Masonry Wall with 1 5/8" x 1 5/8" Steel Studs (16" o.c.) Supporting Interior Finish – Aluminum Window Intersection with Un-Insulated Window Perimeter	
Detail 7.3.18	A.7.70

Interior Insulated Multi-Wythe Brick Masonry Wall with 1 5/8" x 1 5/8" Steel Studs (16" o.c.) Supporting Interior Finish – Aluminum Window Intersection with Insulation at Window Perimeter	
Detail 7.3.19	A.7.71
Interior Insulated Multi-Wythe Brick Masonry Wall with 1 5/8" x 1 5/8" Steel Studs (16" o.c.) Supporting Interior Finish – Aluminum Window Intersection with Aerogel Blanket at Window Perimeter	
Detail 7.3.20	A.7.72
Precast Sandwich Panel Wall Assembly with PVC at Panel Perimeter, Steel Connectors at 24" (o.c.), and 3 5/8" Steel Stud (16" o.c.) – Window Intersection	
Detail 7.3.21	A.7.73
Precast Sandwich Panel Wall Assembly with Wood at Panel Perimeter, Steel Connectors at 24" (o.c.), and 3 5/8" Steel Stud (16" o.c.) – Window Intersection	
Detail 7.3.22	A.7.74
Precast Sandwich Panel Wall Assembly with Gypsum Board at Panel Perimeter, Steel Connectors at 24" (o.c.), and 3 5/8" Steel Stud (16" o.c.) – Window Intersection	
Detail 7.3.23	A.7.75
Precast Sandwich Panel Wall Assembly, Steel Connectors at 24" (o.c.), and 3 5/8" Steel Stud (16" o.c.) – Window Intersection	
Detail 7.4.1	A.7.76
Exterior Insulated Concrete Drained EIFS Wall Assembly – Conventional Curtain Wall Transition	
Detail 7.4.2	A.7.77
Precast Sandwich Panel Wall Assembly with 3 5/8" Steel Stud (16" o.c.) – Curtain Wall Spandrel Transition	
Detail 7.4.3	A.7.78
Interior Insulated Concrete Mass Wall – Conventional Curtain Wall Transition	
Detail 7.4.4	A.7.79
Interior Insulated Concrete Mass Wall – Thermally Broken Curtain Wall Transition	
Detail 7.4.5	A.7.80
Precast Sandwich Panel Wall Assembly – Tigerloc Thermally Broken Curtain Wall Transition	
Detail 7.4.6	A.7.81
Highly Insulated Precast Concrete Sandwich Panel Wall Assembly – High Performance Aluminum Window Sill Detail	
Detail 7.4.7	A.7.82
Highly Insulated Precast Concrete Sandwich Panel Wall Assembly – High Performance Aluminum Window Head Detail	

Detail 7.5.1	A.7.83
Exterior Insulated Concrete Drained EIFS Wall Assembly – Concrete Parapet & Slab Intersection	
Detail 7.5.2	A.7.84
Exterior Insulated Concrete Drained EIFS Wall Assembly – Insulated Concrete Parapet & Slab Intersection	
Detail 7.5.3	A.7.85
Interior Insulated Concrete Mass Wall with 1 5/8" Steel Stud (16" o.c.) Supporting Interior Finish – Concrete Parapet & Roof Intersection	
Detail 7.5.4	A.7.86
Precast Sandwich Panel Wall Assembly with 3 5/8" Steel Stud (16" o.c.) – Steel Roof Deck with Open Web Steel Joist & Parapet Intersection	
Detail 7.5.5	A.7.87
Precast Sandwich Panel – Steel Roof Deck with Open Web Steel Joist & Parapet Intersection	
Detail 7.5.6	A.7.88
Precast Wall Assembly with 3 5/8" x 1 5/8" Steel Stud (16" o.c.) and Rigid Insulation Outboard of Studs – Parapet & Roof Intersection	
Detail 7.5.7	A.7.89
Precast Wall Assembly with 3 5/8" x 1 5/8" Steel Stud (16" o.c.) and Rigid Insulation Outboard of Studs – Parapet & Roof Intersection with Thermal Break under Parapet Stud Cavity and At Anchors	
Detail 7.5.8	A.7.90
Exterior Insulated Concrete Block Wall Assembly with Masonry Ties Supporting Brick Veneer – Parapet & Roof Intersection	
Detail 7.5.9	A.7.91
Precast Sandwich Panel – Steel Roof Deck with Open Web Steel Joist & Paraloc Thermally Broken Parapet Intersection	
Detail 7.5.10	A.7.92
Highly Insulated Precast Concrete Sandwich Panel Wall Assembly – Roof to Wall Intersection with Wood-Framed Parapet	
Detail 7.5.11	A.7.93
Owens Corning Exterior Insulated Concrete Block Wall Assembly with Heckmann Pos-I-Tie Veneer Anchoring System Supporting Brick Veneer – Parapet & Roof Intersection with Uninsulated Parapet	
Detail 7.5.12	A.7.94
Owens Corning Exterior Insulated Concrete Block Wall Assembly with Heckmann Pos-I-Tie Veneer Anchoring System Supporting Brick Veneer – Parapet & Roof Intersection with Insulation Wrapped Around Parapet	
Detail 7.5.13	A.7.95

Window Wall System – Double Glazed Insulated Frame at Concrete Precast Panel Parapet & Roof Intersection	
Detail 7.5.14	A.7.96
Window Wall System – Double Glazed Insulated Frame at Isokorb AXTI Thermally Broken Concrete Parapet & Roof Intersection	
Detail 7.5.15	A.7.97
Window Wall System – Triple Glazed Insulated Frame at Concrete Precast Panel Parapet & Roof Intersection	
Detail 7.5.16	A.7.98
Window Wall System – Triple Glazed Insulated Frame at Isokorb AXTI Thermally Broken Concrete Parapet & Roof Intersection	
Detail 7.6.1	A.7.99
Exterior Insulated Concrete Drained EIFS Wall Assembly – Corner Intersection	
Detail 7.6.2	A.7.100
Highly Insulated Precast Concrete Sandwich Panel Wall Assembly – Outside Corner	
Detail 7.7.1	A.7.101
Interior Insulated Concrete Mass Wall with 3 5/8" x 1 5/8" Steel Studs (16" o.c.) Supporting Interior Finish – Intermediate Floor Intersection above Parking Garage	
Detail 7.7.2	A.7.102
Insulated Concrete Floor Slab – Concrete Column Intersection	
Detail 7.7.3	A.7.103
Precast Sandwich Wall Assembly Slab and Foundation Intersection	
Detail 7.7.4	A.7.104
Precast Sandwich Panel with 3 5/8" Steel Stud (16" o.c.) – Concrete Slab and Foundation Wall	
Detail 7.7.5	A.7.105
Precast Sandwich Panel with 3 5/8" Steel Stud (16" o.c.) – Thermally Broken Concrete Slab and Foundation Intersection	
Detail 7.7.6	A.7.106
Insulated Slab on Grade – Steel Column	
Detail 7.7.7	A.7.107
Insulated Slab on Grade – Armatherm 500 Thermal Break under Column	
Detail 7.7.8	A.7.108
Highly Insulated Precast Concrete Sandwich Panel Wall Assembly – Base of Wall at Foundation with Insulation Skirt	
Detail 7.7.9	A.7.109

Owens Corning Exterior Insulated Concrete Block Wall Assembly with Steel Shelf Angle and Heckmann Pos-I-Tie Veneer Anchoring System Supporting Brick Veneer and Insulation Below Floor – Slab on Grade and Foundation Intersection

Detail 7.7.10A.7.110

Owens Corning Exterior Insulated Concrete Block Wall Assembly with Stainless Steel Stand-off Shelf Angle and Heckmann Pos-I-Tie Veneer Anchoring System Supporting Brick Veneer and Insulation Below Floor – Slab on Grade and Foundation Intersection

Detail 7.8.1A.7.111

Precast Sandwich Panel Wall Assembly – Emloc Thermally Broken Embedment Detail

Detail 7.1.1

Exterior Insulated Concrete Drained EIFS Wall Assembly – Clear Wall

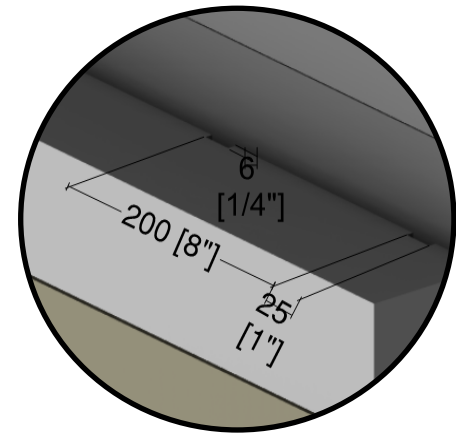
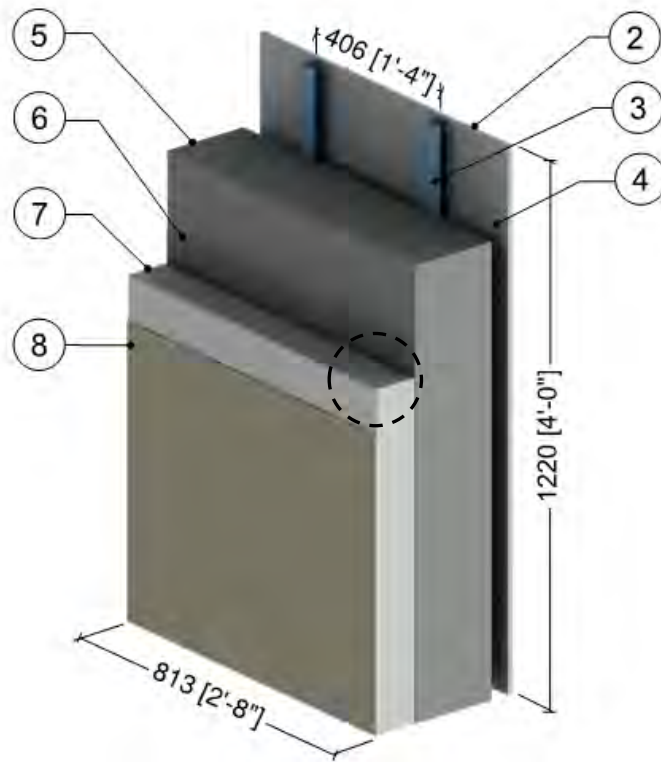

1" (25 mm)
Drained EIFS
Detail

ID	Component	Thickness Inches (mm)	Conductivity Btu-in / ft ² -hr-°F (W/m K)	Nominal Resistance hr-ft ² -°F/Btu (m ² K/W)	Density lb/ft ³ (kg/m ³)	Specific Heat Btu/lb-°F (J/kg K)
1	Interior Films ¹	-	-	R-0.6 (0.11 RSI)	-	-
2	Gypsum Board	1/2" (13)	1.1 (0.16)	R-0.5 (0.08 RSI)	50 (800)	0.26 (1090)
3	1 5/8" x 1 5/8" Steel Studs (16" o.c.)	18 Gauge	430 (62)	-	489 (7830)	0.12 (500)
4	Air in Stud Cavity	1 5/8" (41)	-	R-0.9 (0.16 RSI)	0.075 (1.2)	0.24 (1000)
5	Concrete Wall	8" (203)	12.5 (1.8)	-	140 (2250)	0.20 (850)
6	Weather Resistive Barrier with Adhesive	-	-	-	-	-
7	Insulation Board	4" (100)	0.27 (0.039)	R-15 (2.64 RSI)	1 (16)	0.35 (1470)
8	Lamina	1/8" (4)	6 (0.9)	R-0.04 (0.01 RSI)	120 (1922)	0.20 (850)
9	Exterior Film ¹	-	-	R-0.2 (0.03 RSI)	-	-

¹ Value selected from table 1, p. 26.1 of 2009 ASHRAE Handbook – Fundamentals depending on surface orientation

Detail 7.1.2

Exterior Insulated Concrete Mass Wall Assembly with 1/4 inch (6 mm) Stainless Steel Brackets Supporting 1-1/4" Stone Panels – Clear Wall

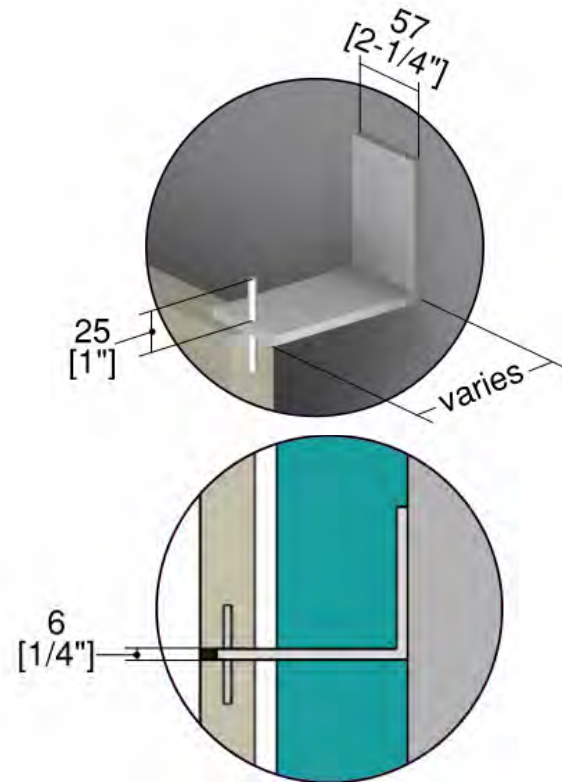
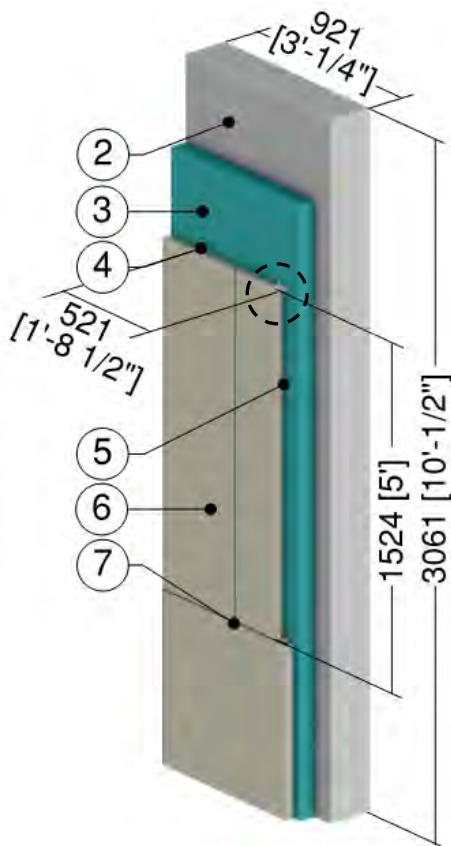

Stainless Steel Bracket Detail

ID	Component	Thickness Inches (mm)	Conductivity Btu-in / ft ² -hr-°F (W/m K)	Nominal Resistance hr-ft ² -°F/Btu (m ² K/W)	Density lb/ft ³ (kg/m ³)	Specific Heat Btu/lb-°F (J/kg K)
1	Interior Film ¹	-	-	R-0.7 (0.12 RSI)	-	-
2	Concrete Mass Wall	8" (203)	12.5 (1.80)	R-0.6 (0.11 RSI)	140 (2250)	0.20 (850)
3	Rigid Insulation	Varies	0.20 (0.029)	R-5 to R-25 (0.88 to 4.40 RSI)	1.8 (28)	0.29 (1220)
4	Stainless Steel Bracket	1/4 (6.3)	118 (17)	-	503 (8060)	0.12 (500)
5	Vented Air Cavity	1/2 (13)	-	R-0.4 (0.07 RSI)	0.075 (1.2)	0.24 (1000)
6	Stone Panel	1-1/4 (32)	43 (6.2)	R-0.03 (0.01 RSI)	160 (2560)	0.21 (880)
7	Panel Sealant	-	1.7 (0.25)	-	-	-
8	Exterior Film ¹	-	-	R-0.2 (0.03 RSI)	-	-

¹ Value selected from table 1, p. 26.1 of 2009 ASHRAE Handbook – Fundamentals depending on surface orientation

Detail 7.1.3

Exterior Insulated Concrete Block Wall with Thermally Broken ISO Clip System with Horizontal Sub-Girt Supporting Cladding – Clear Wall

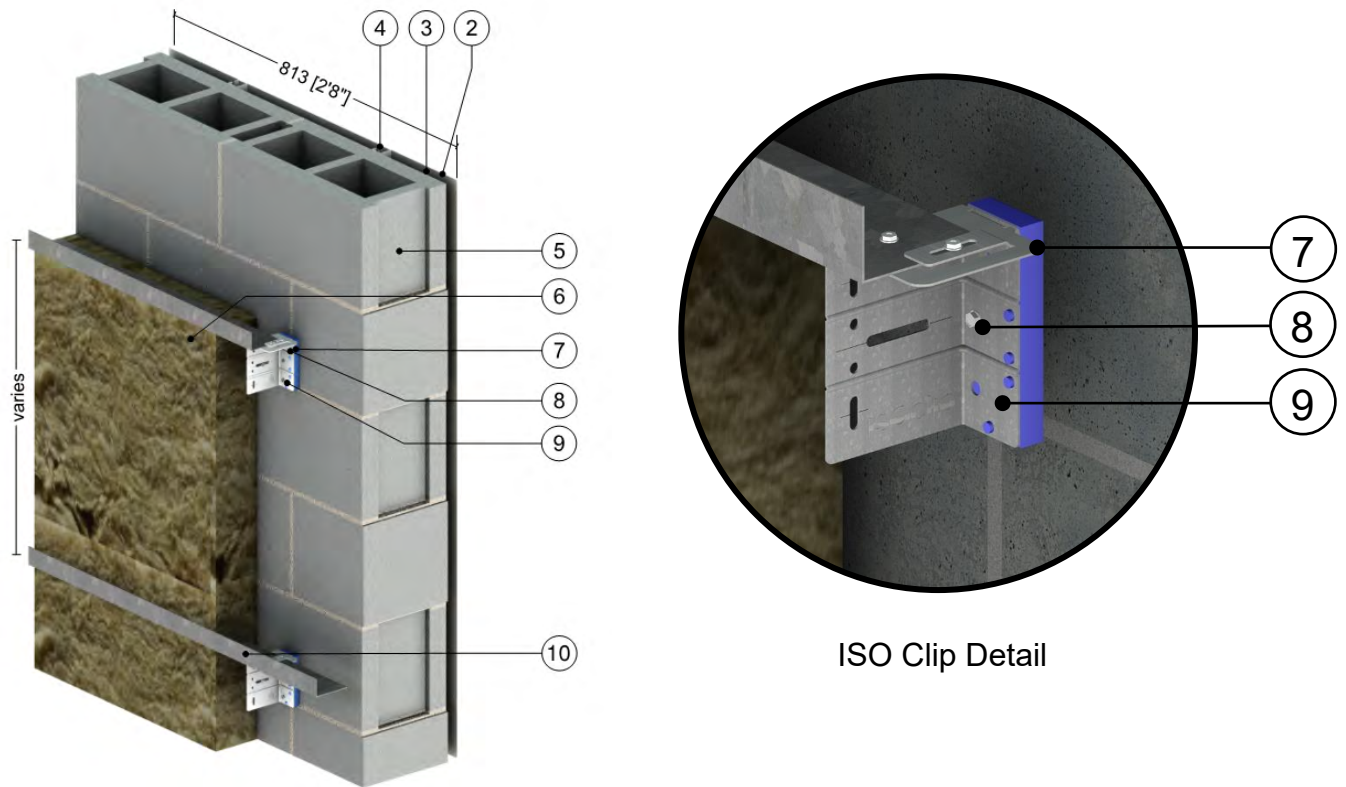

ID	Component	Thickness Inches (mm)	Conductivity Btu-in / ft ² ·hr·°F (W/m K)	Nominal Resistance hr·ft ² ·°F/Btu (m ² K/W)	Density lb/ft ³ (kg/m ³)	Specific Heat Btu/lb·°F (J/kg K)
1	Interior Film ¹	-	-	R-0.7 (0.12 RSI)	-	-
2	Gypsum Board	1/2" (13)	1.1 (0.16)	R-0.5 (0.08 RSI)	50 (800)	0.26 (1090)
3	Air in Stud Cavity	1 5/8" (92)	-	R-0.9 (0.16 RSI)	0.075 (1.2)	0.24 (1000)
4	1 5/8" x 1 5/8" Steel Studs	18 Gauge	430 (62)	-	489 (7830)	0.12 (500)
5	Standard Concrete Blocks	8" (203)	10.3 (1.5)	-	119 (1900)	0.19 (800)
6	Exterior Mineral Wool Insulation	4" to 6" (102 to 152)	0.24 (0.034)	R-16.8 to R-25.2 (2.96 RSI to 4.44 RSI)	4 (64)	0.20 (850)
7	ISO Clip - HDPE Isolator	1/2" (12.7)	3.1 (0.45)	-	-	-
8	#14 Steel Fasteners	1/4" (6) ø	347 (50)	-	489 (7830)	0.12 (500)
9	ISO Clip - Galvanized Metal	14 Gauge	430 (62)	-	489 (7830)	0.12 (500)
10	Horizontal Sub-girt	16 Gauge	430 (62)	-	489 (7830)	0.12 (500)
11	Generic Cladding with 1/2" (13mm) vented air space is incorporated into exterior heat transfer coefficient					
12	Exterior Film ¹	-	-	R-0.7 (0.12 RSI)	-	-

¹ Value selected from table 1, p. 26.1 of 2009 ASHRAE Handbook – Fundamentals depending on surface orientation

Detail 7.1.4

Exterior Insulated Concrete Assembly with Nvelope – NV1 Clip System Supporting Cladding – Clear Wall

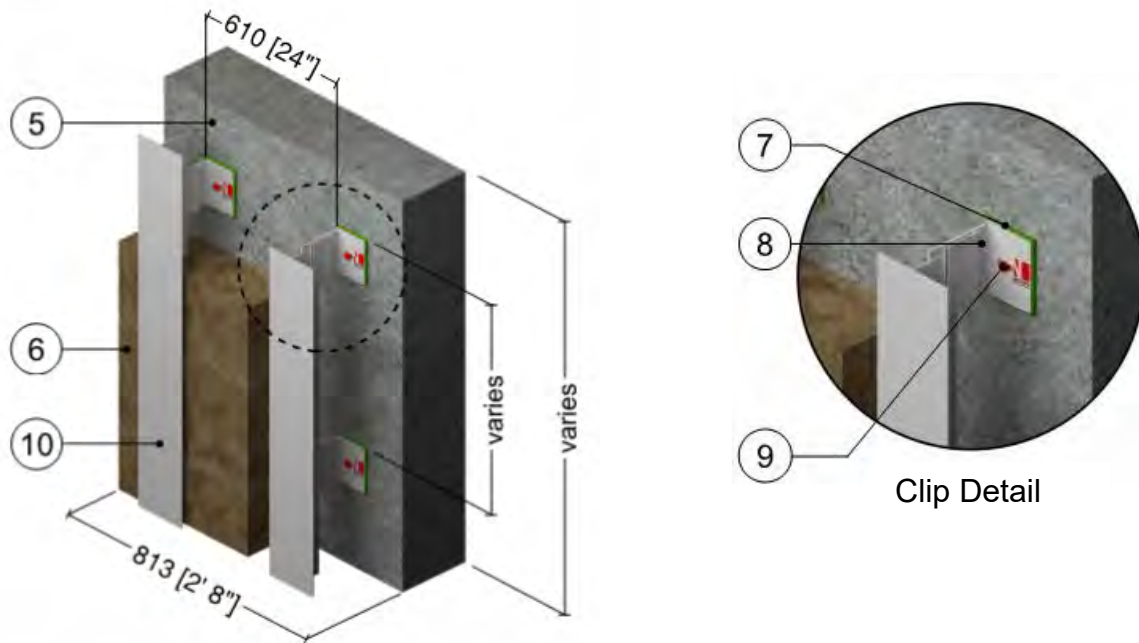

ID	Component	Thickness Inches (mm)	Conductivity Btu-in / ft ² ·hr·°F (W/m K)	Nominal Resistance hr·ft ² ·°F/Btu (m ² K/W)	Density lb/ft ³ (kg/m ³)	Specific Heat Btu/lb·°F (J/kg K)
1	Interior Films ¹	-	-	R-0.7 (0.12 RSI)	-	-
2	Gypsum Board	1/2" (13)	1.1 (0.16)	R-0.5 (0.08 RSI)	50 (800)	0.26 (1090)
3	Air in Stud Cavity	1 5/8" (41)	-	R-0.9 (0.16 RSI)	0.075 (1.2)	0.24 (1000)
4	1 5/8" x 1 5/8" Steel Studs	18 Gauge	430 (62)	-	489 (7830)	0.12 (500)
5	Concrete Wall	8" (203)	12.5 (1.8)	-	140 (2250)	0.20 (850)
6	Exterior Mineral Wool Insulation	2" to 6" (50 to 152)	0.24 (0.034)	R-8.4 to R-25.2 (1.48 RSI to 4.44 RSI)	4 (64)	0.20 (850)
7	NV1 Clip Isolator	0.2" (5)	0.82 (0.117)	-	87 (1400)	0.20 (840)
8	NV1 Clip Extrusion – Aluminum 6005A alloy	Varies	1340 (193)	-	171 (2739)	0.21 (900)
9	#14 Stainless Steel Fasteners	1/4" (6) Ø	118 (17)	-	503 (8060)	0.12 (500)
10	Vertical Sub-girt	0.09" (2.2)	1340 (193)	-	171 (2739)	0.21 (900)
11	Generic Cladding with 1/2" (13mm) vented air space is incorporated into exterior heat transfer coefficient					
12	Exterior Film ¹	-	-	R-0.7 (0.12 RSI)	-	-

¹ Value selected from table 1, p. 26.1 of 2009 ASHRAE Handbook – Fundamentals depending on surface orientation

Detail 7.1.5

Exterior Insulated Concrete Block Wall Assembly with Nvelope – NV1 Clip System Supporting Cladding – Clear Wall

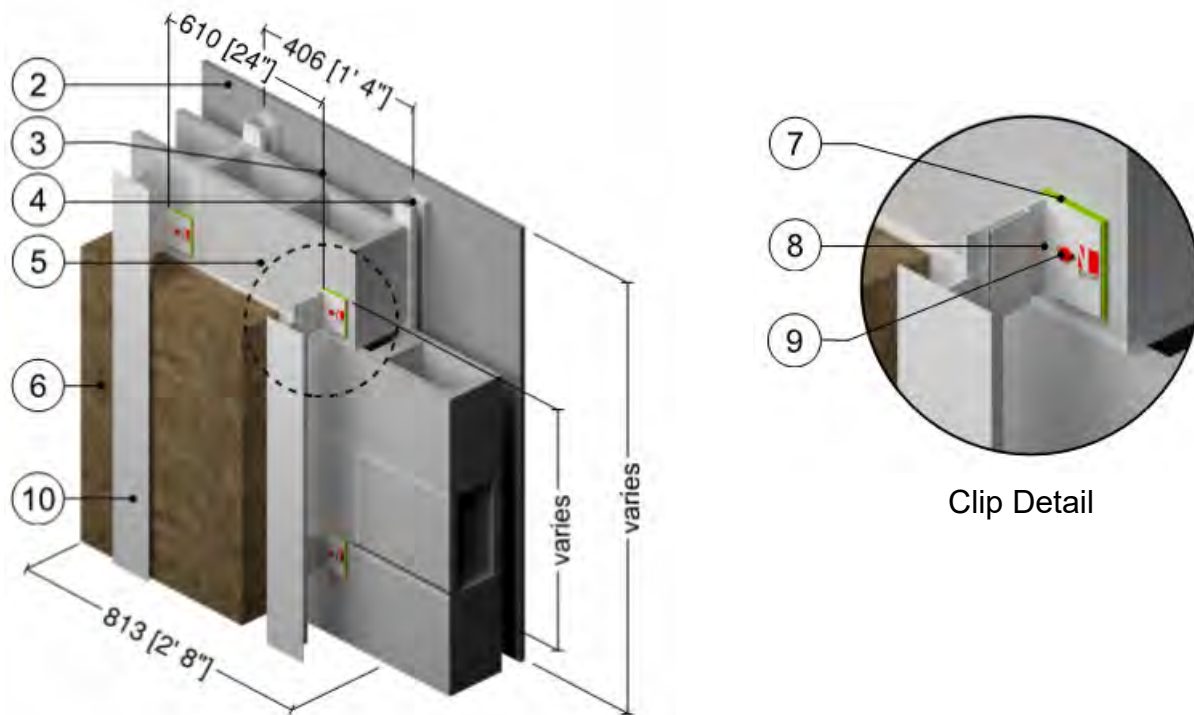

ID	Component	Thickness Inches (mm)	Conductivity Btu-in / ft ² ·hr·°F (W/m K)	Nominal Resistance hr·ft ² ·°F/Btu (m ² K/W)	Density lb/ft ³ (kg/m ³)	Specific Heat Btu/lb·°F (J/kg K)
1	Interior Films ¹	-	-	R-0.7 (0.12 RSI)	-	-
2	Gypsum Board	1/2" (13)	1.1 (0.16)	R-0.5 (0.08 RSI)	50 (800)	0.26 (1090)
3	Air in Stud Cavity	1 5/8" (41)	-	R-0.9 (0.16 RSI)	0.075 (1.2)	0.24 (1000)
4	1 5/8" x 1 5/8" Steel Studs	18 Gauge	430 (62)	-	489 (7830)	0.12 (500)
5	Standard Concrete Block	7-5/8" (190)	10.3 (1.5)	-	119 (1900)	0.19 (800)
6	Exterior Mineral Wool Insulation	2" to 6" (50 to 152)	0.24 (0.034)	R-8.4 to R-25.2 (1.48 RSI to 4.44 RSI)	4 (64)	0.20 (850)
7	NV1 Clip Isolator	0.2" (5)	0.82 (0.117)	-	87 (1400)	0.20 (840)
8	NV1 Clip Extrusion – Aluminum 6005A alloy	Varies	1340 (193)	-	171 (2739)	0.21 (900)
9	#14 Stainless Steel Fasteners	1/4" (6) ∅	118 (17)	-	503 (8060)	0.12 (500)
10	Vertical Sub-girt	0.09" (2.2)	1340 (193)	-	171 (2739)	0.21 (900)
11	Generic Cladding with 1/2" (13mm) vented air space is incorporated into exterior heat transfer coefficient					
12	Exterior Film ¹	-	-	R-0.7 (0.12 RSI)	-	-

¹ Value selected from table 1, p. 26.1 of 2009 ASHRAE Handbook – Fundamentals depending on surface orientation

Detail 7.1.6

Exterior Insulated Concrete Mass Wall Assembly with Hohmann & Barnard Masonry Zinc 2-Seal Anchor Supporting Brick Veneer – Clear Wall

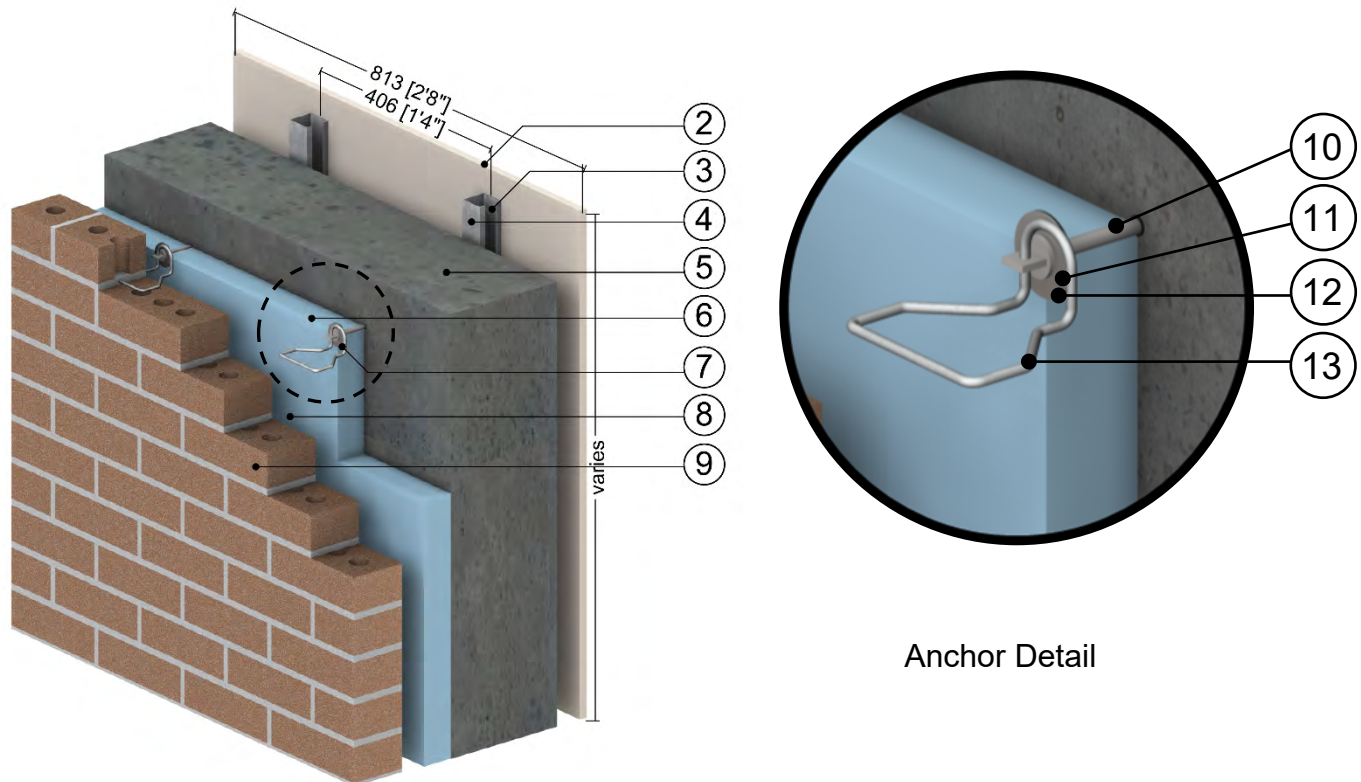

Anchor Detail

ID	Component	Thickness Inches (mm)	Conductivity Btu-in / ft ² -hr-°F (W/m K)	Nominal Resistance hr-ft ² -°F/Btu (m ² K/W)	Density lb/ft ³ (kg/m ³)	Specific Heat Btu/lb-°F (J/kg K)
1	Interior Film ¹	-	-	R-0.7 (0.12 RSI)	-	-
2	Gypsum Board	1/2" (13)	1.1 (0.16)	R-0.5 (0.08 RSI)	50 (800)	0.26 (1090)
3	Air in Stud Cavity	3 5/8" (92)	-	R-0.9 (0.16 RSI)	0.075 (1.2)	0.24 (1000)
4	1 5/8" x 1 5/8" Steel Studs	18 Gauge	430 (62)	-	489 (7830)	0.12 (500)
5	Concrete Mass Wall	8" (203)	12.5 (1.8)	-	140 (2250)	0.20 (850)
6	Exterior Mineral Wool Insulation	1" to 4" (25 to 102)	0.24 (0.034)	R-4.2 to R-16.8 (0.74 RSI to 2.96 RSI)	4 (64)	0.20 (850)
7	Brick Tie	1" to 4" (25 to 102)	784 (113)	-	445 (7130)	0.09 (390)
8	Vented Air Cavity	1.5" (38)	-	R-0.4 (0.07 RSI)	0.075 (1.2)	0.24 (1000)
9	Brick Veneer	3 5/8" (92)	5.4 (0.78)	-	120 (1920)	0.19 (720)
10	Zinc Barrel	-	784 (113)	-	-	-
11	Steel Washer	1.5" (38) ∅	347 (50)	-	489 (7830)	0.12 (500)
12	Rubber Washer (EPDM)	-	1.7 (0.25)	-	-	-
13	Galvanized Steel Wire Pintle	3/16" (5) ∅	430 (62)	-	489 (7830)	0.12 (500)
14	Exterior Film ¹	-	-	R-0.2 (0.03 RSI)	-	-

¹ Value selected from table 1, p. 26.1 of 2009 ASHRAE Handbook – Fundamentals depending on surface orientation

Detail 7.1.7

Exterior Insulated Concrete Mass Wall Assembly with Hohmann & Barnard Masonry Stainless Steel 2-Seal Thermal Wing Nut Anchor Supporting Brick Veneer – Clear Wall

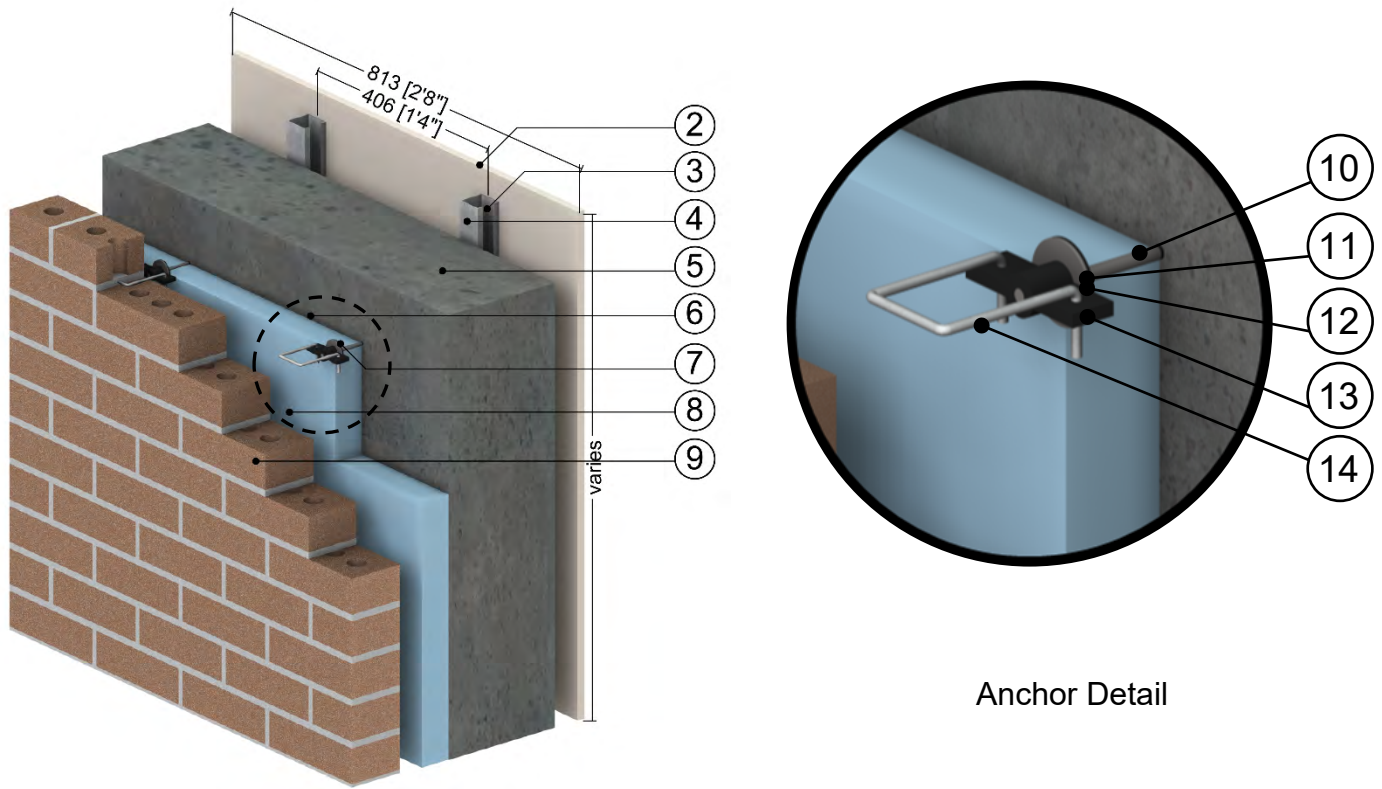

ID	Component	Thickness Inches (mm)	Conductivity Btu-in / ft ² ·hr·°F (W/m K)	Nominal Resistance hr·ft ² ·°F/Btu (m ² K/W)	Density lb/ft ³ (kg/m ³)	Specific Heat Btu/lb·°F (J/kg K)
1	Interior Film ¹	-	-	R-0.7 (0.12 RSI)	-	-
2	Gypsum Board	1/2" (13)	1.1 (0.16)	R-0.5 (0.08 RSI)	50 (800)	0.26 (1090)
3	Air in Stud Cavity	3 5/8" (92)	-	R-0.9 (0.16 RSI)	0.075 (1.2)	0.24 (1000)
4	1 5/8" x 1 5/8" Steel Studs	18 Gauge	430 (62)	-	489 (7830)	0.12 (500)
5	Concrete Mass Wall	8" (203)	12.5 (1.8)	-	140 (2250)	0.20 (850)
6	Exterior Mineral Wool Insulation	1" to 4" (25 to 102)	0.24 (0.034)	R-4.2 to R-16.8 (0.74 RSI to 2.96 RSI)	4 (64)	0.20 (850)
7	Brick Tie	1" to 4" (25 to 102)	784 (113)	-	445 (7130)	0.09 (390)
8	Vented Air Cavity	1.5" (38)	-	R-0.4 (0.07 RSI)	0.075 (1.2)	0.24 (1000)
9	Brick Veneer	3 5/8" (92)	5.4 (0.78)	-	120 (1920)	0.19 (720)
10	Stainless Steel Barrel	-	118 (17)	-	503 (8060)	0.12 (500)
11	Steel Washer	1.5" (38) ∅	347 (50)	-	489 (7830)	0.12 (500)
12	Rubber Washer (EPDM)	-	1.7 (0.25)	-	-	-
13	Steel Wing Nut with Plastic Coating	Varies	347 (50)	-	489 (7830)	0.12 (500)
14	Galvanized Steel Wire Pintle	3/16" (5) ∅	430 (62)	-	489 (7830)	0.12 (500)
15	Exterior Film ¹	-	-	R-0.2 (0.03 RSI)	-	-

¹ Value selected from table 1, p. 26.1 of 2009 ASHRAE Handbook – Fundamentals depending on surface orientation

Detail 7.1.8

Precast Sandwich Panel Wall Assembly with Concrete Panel Joints – Clear Wall

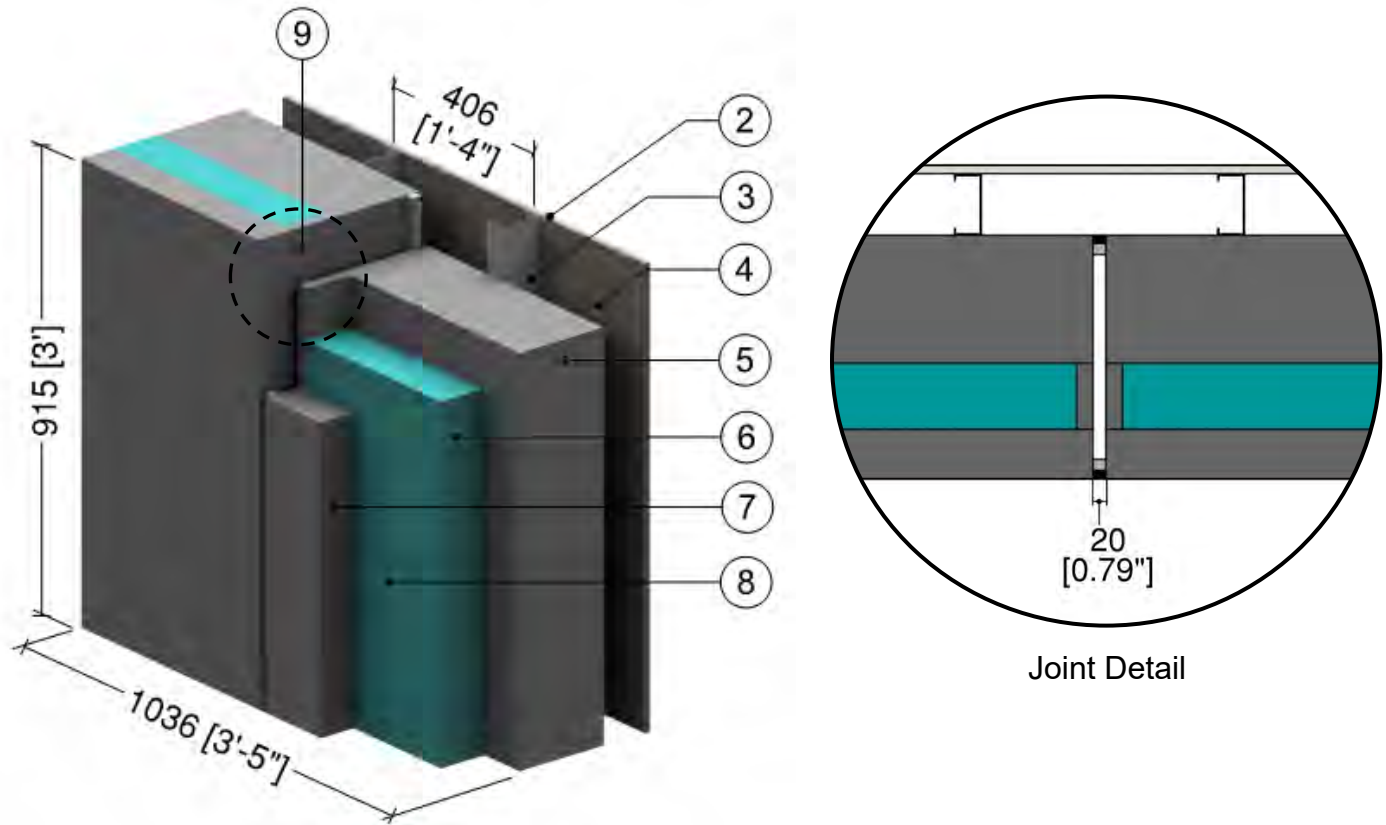

ID	Component	Thickness Inches (mm)	Conductivity Btu-in / ft ² ·hr·°F (W/m K)	Nominal Resistance hr·ft ² ·°F/Btu (m ² K/W)	Density lb/ft ³ (kg/m ³)	Specific Heat Btu/lb·°F (J/kg K)
1	Interior Film ¹	-	-	R-0.7 (0.12 RSI)	-	-
2	Gypsum Board	1/2" (13)	1.1 (0.16)	R-0.5 (0.08 RSI)	50 (800)	0.26 (1090)
3	3 5/8" x 1 5/8" Steel Studs	18 Gauge	430 (62)	-	489 (7830)	0.12 (500)
4	Air in Stud Cavity	4 1/8" (130)	-	R-0.9 (RSI-0.16)	0.075 (1.2)	0.24 (1000)
5	Precast Sandwich Panel, Interior Concrete Panel	7 3/4" (197)	12.5 (1.8)	-	140 (2250)	0.20 (850)
6	Precast Sandwich Panel Insulation	2" to 4" (51 to 102)	-	R-10 to R-20 (1.8 to 3.5 RSI)	1.8 (28)	0.29 (1220)
7	Precast Sandwich Panel, Exterior Concrete Panel	3" (76)	12.5 (1.8)	-	140 (2250)	0.20 (850)
8	Precast Sandwich Panel, Structural Ties @ 24" (610) o.c.	16 Gauge	430 (62)	-	489 (7830)	0.12 (500)
9	Concrete Panel Joint	1" (25)	12.5 (1.8)	-	140 (2250)	0.20 (850)
10	Exterior Film ¹	-	-	R-0.2 (0.03 RSI)	-	-

¹ Value selected from table 1, p. 26.1 of 2009 ASHRAE Handbook – Fundamentals depending on surface orientation

Detail 7.1.9

Precast Sandwich Panel Wall Assembly with Tigerloc Thermally Broken Panel Joints – Clear Wall

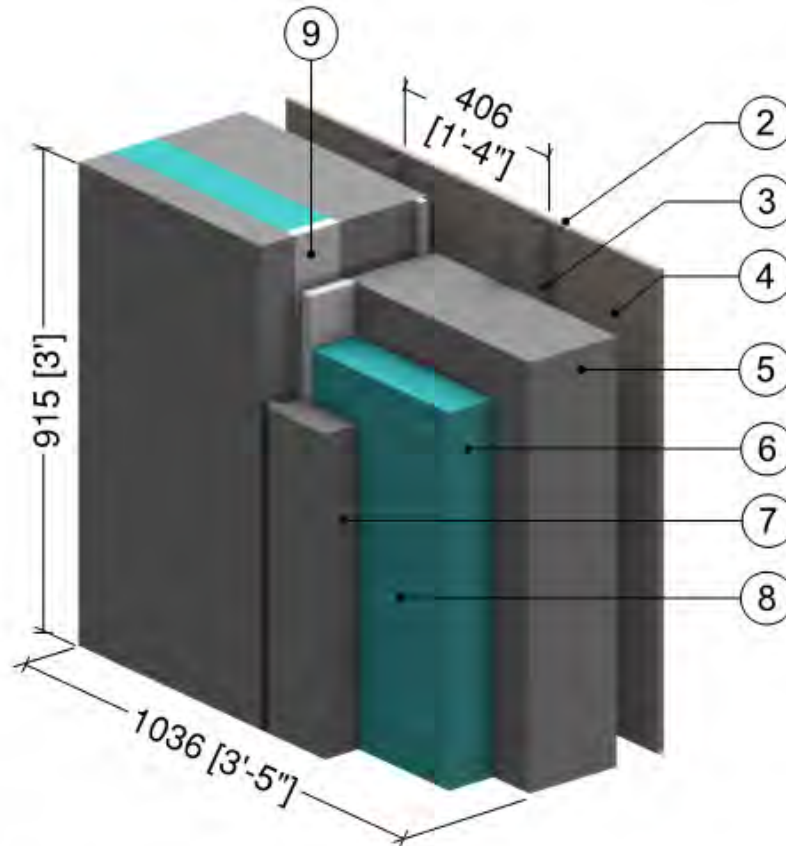

ID	Component	Thickness Inches (mm)	Conductivity Btu-in / ft ² ·hr·°F (W/m K)	Nominal Resistance hr·ft ² ·°F/Btu (m ² K/W)	Density lb/ft ³ (kg/m ³)	Specific Heat Btu/lb·°F (J/kg K)
1	Interior Film ¹	-	-	R-0.7 (0.12 RSI)	-	-
2	Gypsum Board	1/2" (13)	1.1 (0.16)	R-0.5 (0.08 RSI)	50 (800)	0.26 (1090)
3	3 5/8" x 1 5/8" Steel Studs	18 Gauge	430 (62)	-	489 (7830)	0.12 (500)
4	Air in Stud Cavity	4 1/8" (130)	-	R-0.9 (RSI-0.16)	0.075 (1.2)	0.24 (1000)
5	Precast Sandwich Panel, Interior Concrete Panel	7 3/4" (197)	12.5 (1.8)	-	140 (2250)	0.20 (850)
6	Precast Sandwich Panel Insulation	2" to 4" (51 to 102)	-	R-10 to R-20 (1.8 to 3.5 RSI)	1.8 (28)	0.29 (1220)
7	Precast Sandwich Panel, Exterior Concrete Panel	3" (76)	12.5 (1.8)	-	140 (2250)	0.20 (850)
8	Precast Sandwich Panel, Structural Ties @ 24" (610) o.c.	16 Gauge	430 (62)	-	489 (7830)	0.12 (500)
9	Tigerloc, PVC Foam	1" (25)	0.42 (0.06)	-	-	-
10	Exterior Film ¹	-	-	R-0.2 (0.03 RSI)	-	-

¹ Value selected from table 1, p. 26.1 of 2009 ASHRAE Handbook – Fundamentals depending on surface orientation

Detail 7.1.10

Precast Concrete Sandwich Panel Wall Assembly with FRP Connectors – Clear Wall

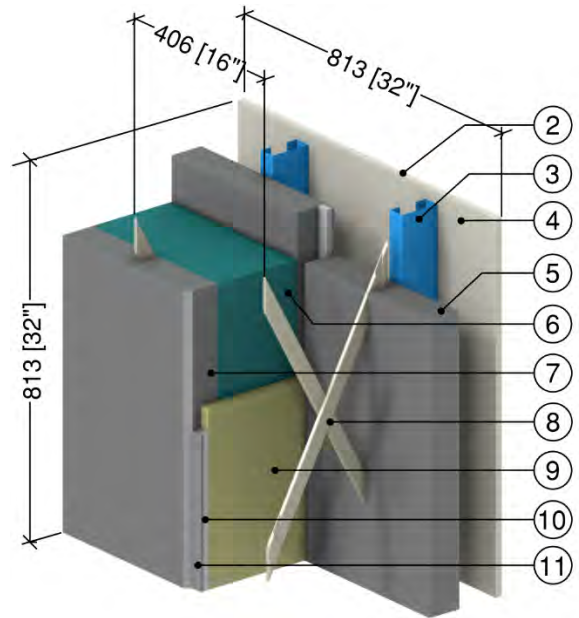
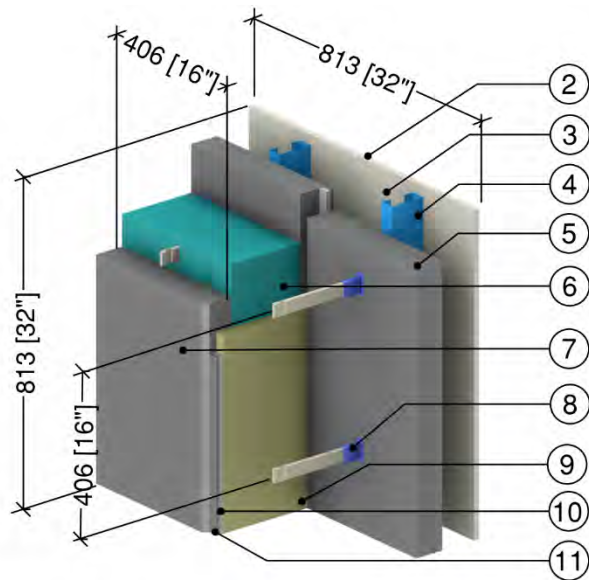

ID	Component	Thickness Inches (mm)	Conductivity Btu-in / ft ² -hr-°F (W/m K)	Nominal Resistance hr-ft ² -°F/Btu (m ² K/W)	Density lb/ft ³ (kg/m ³)	Specific Heat Btu/lb-°F (J/kg K)
1	Interior Film ¹	-	-	R-0.7 (0.12 RSI)	-	-
2	Gypsum Board	5/8" (15)	1.1 (0.16)	R-0.5 (0.09 RSI)	50 (800)	0.26 (1090)
3	3 5/8" x 1 5/8" Steel Studs with Top and Bottom Tracks	18 Gauge	430 (62)	-	489 (7830)	0.12 (500)
4	Air in Stud Cavity	3 5/8" (92)	-	R-0.9 (0.16 RSI)	0.075 (1.2)	0.24 (1000)
5	Precast Sandwich Panel, Interior Concrete Panel	3" (76)	12.5 (1.8)	-	140 (2250)	0.20 (850)
6	Precast Sandwich Panel Insulation	8" (203)	-	R-40 (7.04 RSI) to R-56 (9.86 RSI)	1.8 (28)	0.29 (1220)
7	Precast Sandwich Panel, Exterior Concrete Panel	3" (76)	12.5 (1.8)	-	140 (2250)	0.20 (850)
8	Precast Sandwich Panel, FRP Connectors	-	6.93 (1)	-	-	-
9	Mineral Wool Insulation	-	0.238 (0.034)	-	4 (64)	0.20 (850)
10	Backer Rod	-	0.25 (0.036)	-	-	-
11	Sealant	-	1.73 (0.25)	-	-	-
12	Exterior Film ¹	-	-	R-0.2 (0.03 RSI)	-	-

¹ Value selected from table 1, p. 26.1 of 2009 ASHRAE Handbook – Fundamentals depending on surface orientation

Detail 7.1.11

Exterior Insulated Concrete Block Wall with Armadillo FRR Horizontal Z-Girts Supporting Cladding – Clear Wall

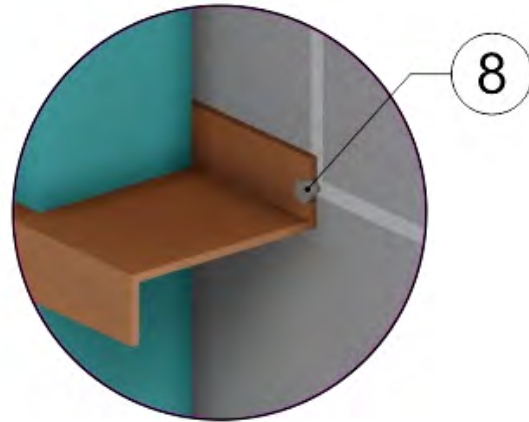
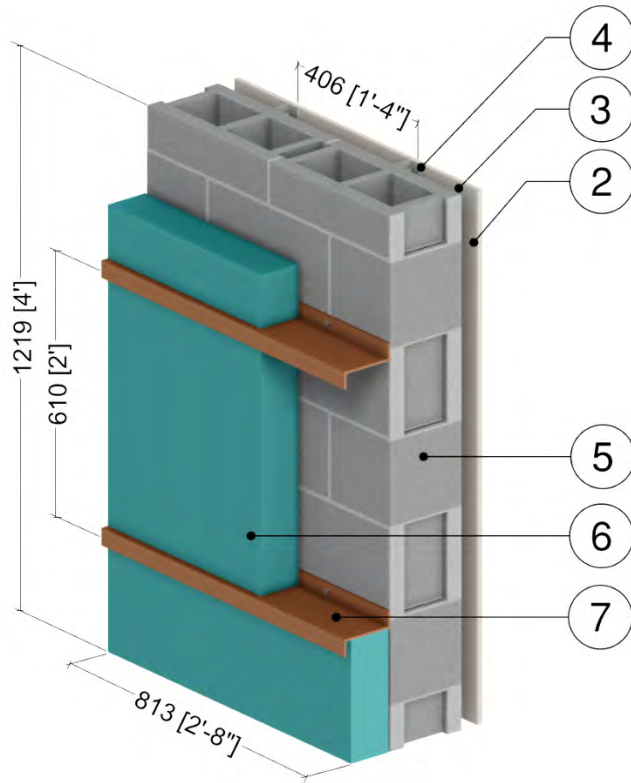

FRR Girt Detail

ID	Component	Thickness Inches (mm)	Conductivity Btu-in / ft ² -hr-°F (W/m K)	Nominal Resistance hr-ft ² -°F/Btu (m ² K/W)	Density lb/ft ³ (kg/m ³)	Specific Heat Btu/lb-°F (J/kg K)
1	Interior Film ¹	-	-	R-0.7 (0.12 RSI)	-	-
2	Gypsum Board	1/2" (13)	1.1 (0.16)	R-0.5 (0.08 RSI)	50 (800)	0.26 (1090)
3	Air in Stud Cavity	3 5/8" (92)	-	R-0.9 (0.16 RSI)	0.075 (1.2)	0.24 (1000)
4	1 5/8" x 1 5/8" Steel Studs	18 Gauge	430 (62)	-	489 (7830)	0.12 (500)
5	Standard Concrete Blocks	8" (203)	10.3 (1.5)	-	119 (1900)	0.19 (800)
6	Exterior Insulation	Varies	-	R-10.0 to R-25.0 (1.76 RSI to 4.40 RSI)	4 (64)	0.20 (850)
7	Armadillo FRR Girt	-	1.4 (0.2)	-	85 (5.3)	-
8	#12 Steel Fasteners (16" o.c.)	7/32" (5.5) ∅	347 (50)	-	489 (7830)	0.12 (500)
9	Generic Cladding with 1/2" (13mm) vented air space is incorporated into exterior heat transfer coefficient					
10	Exterior Film ¹	-	-	R-0.7 (0.12 RSI)	-	-

¹Value selected from table 1, p. 26.1 of 2009 ASHRAE Handbook – Fundamentals depending on surface orientation

Detail 7.1.12

Exterior Insulated Concrete Block Wall with Vertical Clips Supporting Cladding – Clear Wall

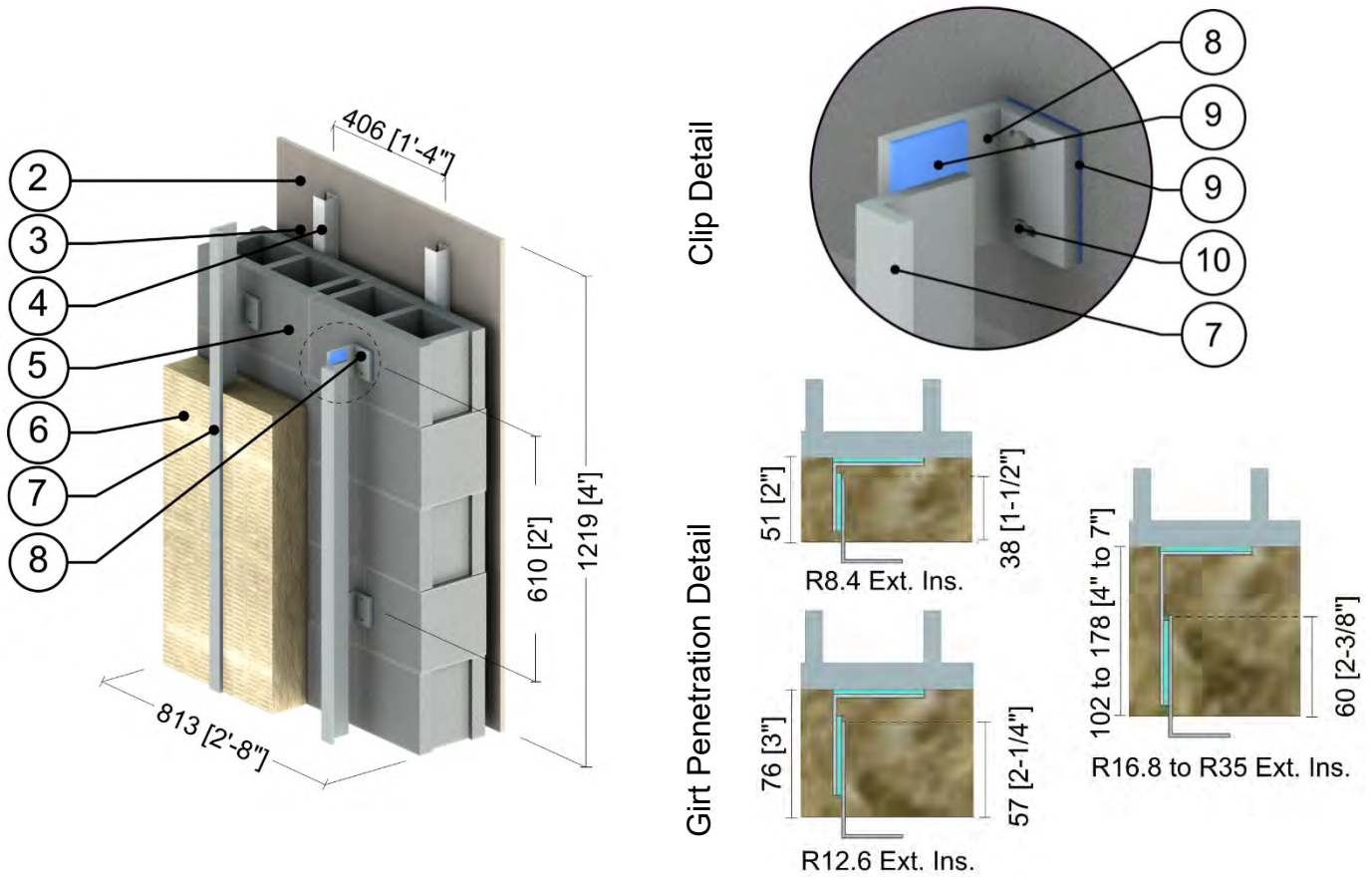

ID	Component	Thickness Inches (mm)	Conductivity Btu-in / ft ² ·hr·°F (W/m K)	Nominal Resistance hr·ft ² ·°F/Btu (m ² K/W)	Density lb/ft ³ (kg/m ³)	Specific Heat Btu/lb·°F (J/kg K)
1	Interior Films ¹	-	-	R-0.7 (0.12 RSI)	-	-
2	Gypsum Board	1/2" (13)	1.1 (0.16)	R-0.5 (0.08 RSI)	50 (800)	0.26 (1090)
3	Air in Stud Cavity	1 5/8" (41)	-	R-0.9 (0.16 RSI)	0.075 (1.2)	0.24 (1000)
4	1 5/8" x 1 5/8" Steel Studs	18 Gauge	430 (62)	-	489 (7830)	0.12 (500)
5	Standard Concrete Blocks	8" (203)	10.3 (1.5)	-	119 (1900)	0.19 (800)
6	Exterior Mineral Wool Insulation	varies	0.24 (0.034)	R-4.2 to R-29.4 (0.74 to 5.18 RSI)	4 (64)	0.20 (850)
7	Vertical Aluminum L-girt	0.09" (2.2)	1339 (193)	-	169 (2700)	0.22 (900)
8	Aluminum Clip	0.09" (2.2)	1110 (160)	-	171 (2739)	0.21 (900)
9	HDPE Isolator	1/8" (3)	3.5 (0.5)	-	59 (950)	0.48 (2000)
10	#14 Stainless Steel Fasteners	1/4" (6) Ø	118 (17)	-	500 (8000)	0.12 (500)
11	Cladding with 1/2" vented airspace incorporated into exterior heat transfer coefficient					
12	Exterior Film ¹	-	-	R-0.7 (0.12 RSI)	-	-

¹ Value selected from table 1, p. 26.1 of 2009 ASHRAE Handbook – Fundamentals depending on surface orientation

Detail 7.1.13

Exterior Insulated Concrete Block Wall Assembly with Brick Ties Supporting Brick Veneer – Clear Wall

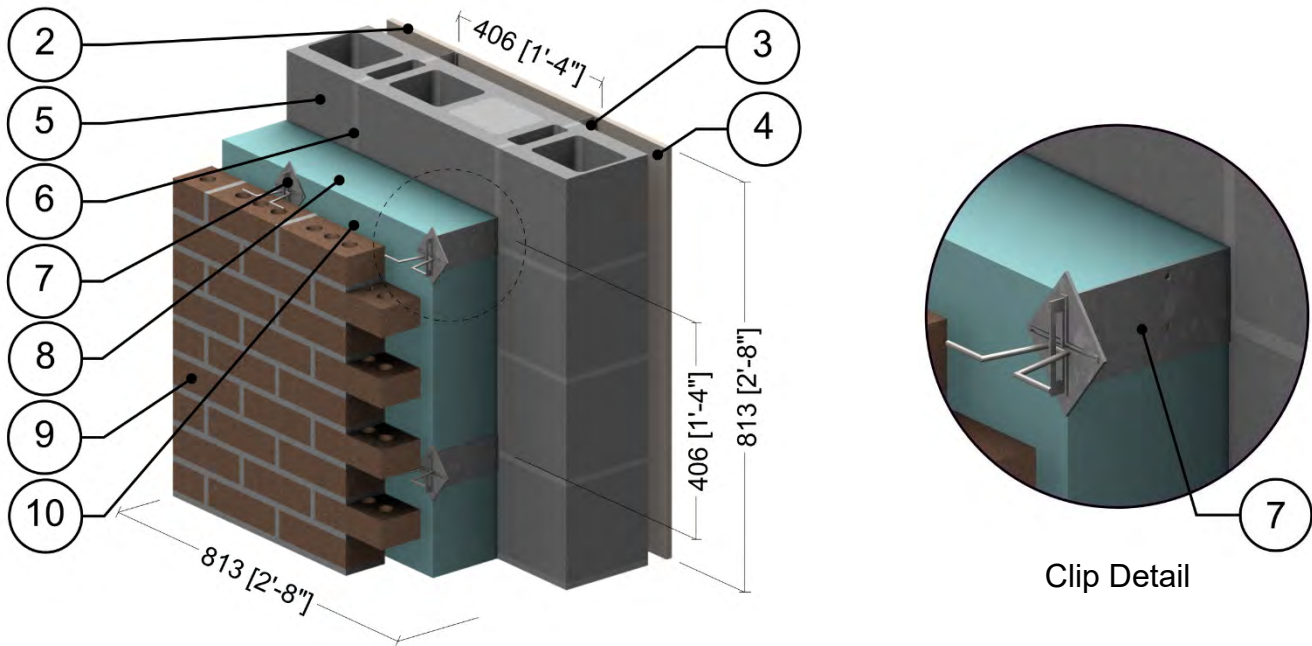

ID	Component	Thickness Inches (mm)	Conductivity Btu-in / ft ² -hr-°F (W/m K)	Nominal Resistance hr-ft ² -°F/Btu (m ² K/W)	Density lb/ft ³ (kg/m ³)	Specific Heat Btu/lb-°F (J/kg K)
1	Interior Film ¹	-	-	R-0.7 (0.12 RSI)	-	-
2	Gypsum Board	1/2" (13)	1.1 (0.16)	R-0.5 (0.08 RSI)	50 (800)	0.26 (1090)
3	1 5/8" Steel Studs with Metal Tracks	20 Gauge	430 (62)	-	489 (7830)	0.12 (500)
4	Air in Stud Cavity	1 5/8" (41)	-	R-0.9 (0.16 RSI)	0.075 (1.2)	0.24 (1000)
5	Standard Concrete Block	7 5/8" (190)	3.5 (0.5)	-	119 (1900)	0.19 (800)
6	Cement Mortar	-	3.5 (0.5)	-	113 (1800)	0.12 (500)
7	Masonry Ties @ 16" (406) o.c.	14 Gauge	347 (50)	-	489 (7830)	0.12 (500)
8	Exterior Insulation	Varies	-	R-5 to R-35 (0.88 RSI to 6.2 RSI)	1.8 (28)	0.29 (1220)
9	Brick Veneer	3 5/8" (92)	5.4 (0.78)	-	120 (1920)	0.19 (720)
10	Air Gap	1" (25)	-	R-0.9 (0.16 RSI)	0.075 (1.2)	0.24 (1000)
11	Exterior Film ¹	-	-	R-0.2 (0.03 RSI)	-	-

¹ Value selected from table 1, p. 26.1 of 2009 ASHRAE Handbook – Fundamentals depending on surface orientation

Detail 7.1.14

Interior Insulated Concrete Mass Wall with 1 5/8" Steel Stud (16" o.c.) Supporting Interior Finish Wall Assembly – Clear Wall

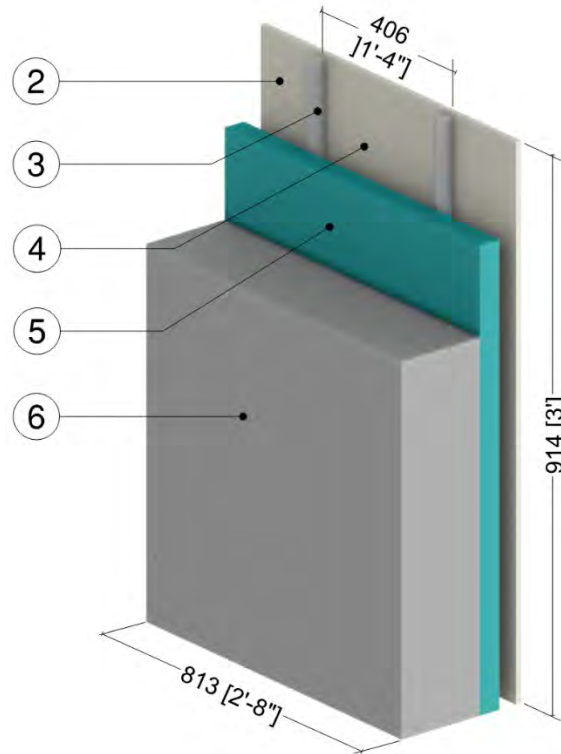

ID	Component	Thickness Inches (mm)	Conductivity Btu·in / ft ² ·hr·°F (W/m K)	Nominal Resistance hr·ft ² ·°F/Btu (m ² K/W)	Density lb/ft ³ (kg/m ³)	Specific Heat Btu/lb·°F (J/kg K)
1	Interior Film ¹	-	-	R-0.7 (0.12 RSI)	-	-
2	Gypsum Board	1/2" (13)	1.1 (0.16)	R-0.5 (0.08 RSI)	50 (800)	0.26 (1090)
3	1 5/8" x 1 5/8" Steel Studs	18 Gauge	430 (62)	-	489 (7830)	0.12 (500)
4	Air in Stud Cavity	1 5/8" (41)	-	R-0.9 (0.16 RSI)	0.075 (1.2)	0.24 (1000)
5	Interior Insulation	Varies	-	R-10 to R-15 (1.76 RSI to 2.64 RSI)	1.8 (28)	0.29 (1220)
6	Exterior Concrete Mass Wall	8" (203)	12.5 (1.8)	-	140 (2250)	0.20 (850)
7	Exterior Film ¹	-	-	R-0.2 (0.03 RSI)	-	-

¹ Value selected from table 1, p. 26.1 of 2009 ASHRAE Handbook – Fundamentals depending on surface orientation

Detail 7.1.15

Precast Sandwich Panel Wall Assembly with Steel Connectors and 3 5/8" x 1 5/8" Steel Stud (16" o.c.) – Clear Wall

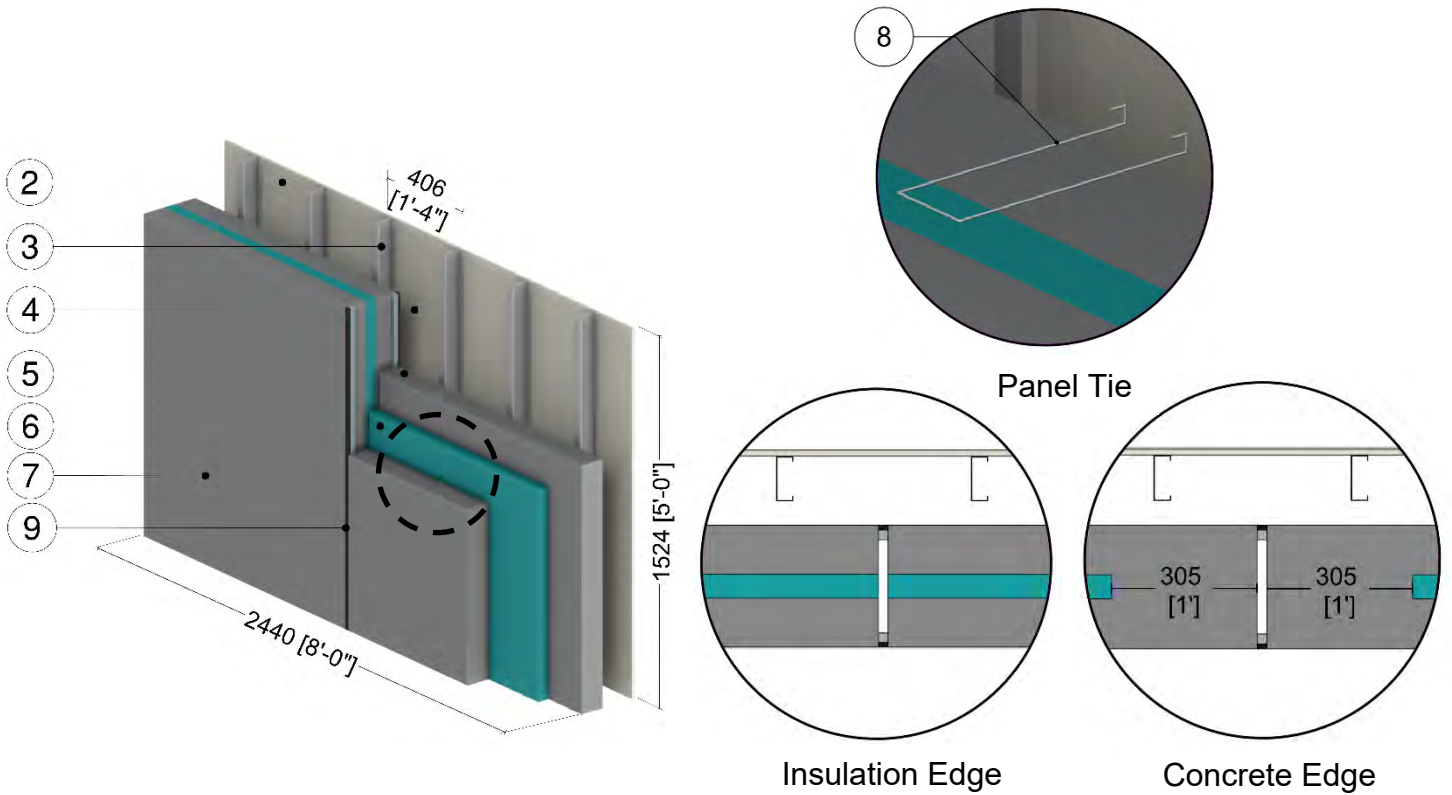

ID	Component	Thickness Inches (mm)	Conductivity Btu-in / ft ² -hr-°F (W/m K)	Nominal Resistance hr-ft ² -°F/Btu (m ² K/W)	Density lb/ft ³ (kg/m ³)	Specific Heat Btu/lb-°F (J/kg K)
1	Interior Film ¹	-	-	R-0.7 (0.12 RSI)	-	-
2	Gypsum Board	1/2" (13)	1.1 (0.16)	R-0.5 (0.08 RSI)	50 (800)	0.26 (1090)
3	3 5/8" x 1 5/8" Steel Studs	18 Gauge	430 (62)	-	489 (7830)	0.12 (500)
4	Air in Stud Cavity	5 5/8" (143)	-	R-0.9 (0.16 RSI)	0.075 (1.2)	0.24 (1000)
5	Precast Sandwich Panel, Interior Concrete	4" (102)	12.5 (1.8)	-	140 (2250)	0.20 (850)
6	Precast Sandwich Panel, Insulation	Varies	-	R-10 to R-20 (1.76 RSI to 3.52 RSI)	1.8 (28)	0.29 (1220)
7	Precast Sandwich Panel, Exterior Concrete	4" (102)	12.5 (1.8)	-	140 (2250)	0.20 (850)
8	Precast Sandwich Panel, Steel Connectors at various spacing	16 Gauge	430 (62)	-	489 (7830)	0.12 (500)
9	Sealant	-	2.4 (3.5)	-	174 (2800)	0.17 (700)
10	Exterior Film ¹	-	-	R-0.2 (0.03 RSI)	-	-

¹ Value selected from table 1, p. 26.1 of 2009 ASHRAE Handbook – Fundamentals depending on surface orientation

Detail 7.1.16

Exterior Insulated Concrete Mass Wall Assembly with 3/8 inch (9.5 mm) Stainless Steel Brackets Supporting 3" Stone Panels – Clear Wall

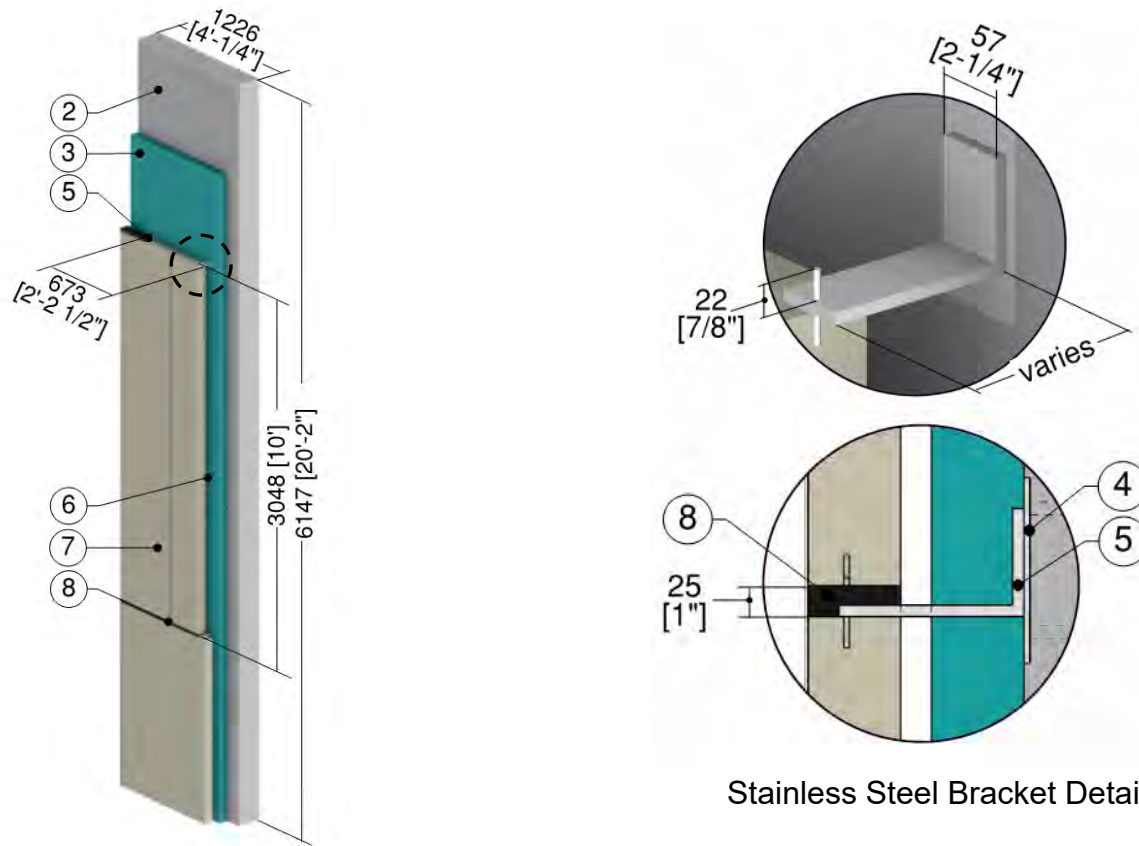

Stainless Steel Bracket Detail

ID	Component	Thickness Inches (mm)	Conductivity Btu-in / ft ² -hr-°F (W/m K)	Nominal Resistance hr-ft ² -°F/Btu (m ² K/W)	Density lb/ft ³ (kg/m ³)	Specific Heat Btu/lb-°F (J/kg K)
1	Interior Film ¹	-	-	R-0.7 (0.12 RSI)	-	-
2	Concrete Mass Wall	8 (203)	12.5 (1.80)	R-0.6 (0.11 RSI)	140 (2250)	0.20 (850)
3	Rigid Insulation	Varies	0.20 (0.029)	R-5.0 to R-25.0 (0.88 to 4.40 RSI)	1.8 (28)	0.29 (1220)
4	Bracket Mount	3/16 (4.8)	347 (50)	-	489 (7830)	0.12 (500)
5	Stainless Steel Bracket	3/8 (9.5)	118 (17)	-	503 (8060)	0.12 (500)
6	Vented Air Cavity	1.0 (25)	-	R-0.4 (0.07 RSI)	0.075 (1.2)	0.24 (1000)
7	Stone Panel	3 (76)	43 (6.2)	R-0.07 (0.01 RSI)	160 (2560)	0.21 (880)
8	Panel Sealant	-	1.7 (0.25)	-	-	-
9	Exterior Film ¹	-	-	R-0.2 (0.03 RSI)	-	-

¹ Value selected from table 1, p. 26.1 of 2009 ASHRAE Handbook – Fundamentals depending on surface orientation

Detail 7.1.17

Exterior Insulated Concrete Block Wall Assembly with SOPREMA SOPRA-XPS 20 and ACS-S Thermal Clip (16" o.c. Horizontal) Supporting Metal Cladding - Clear Wall

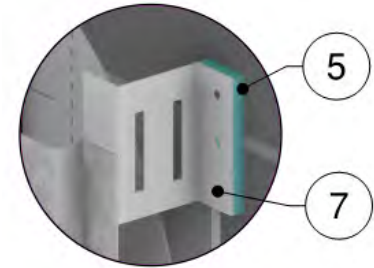
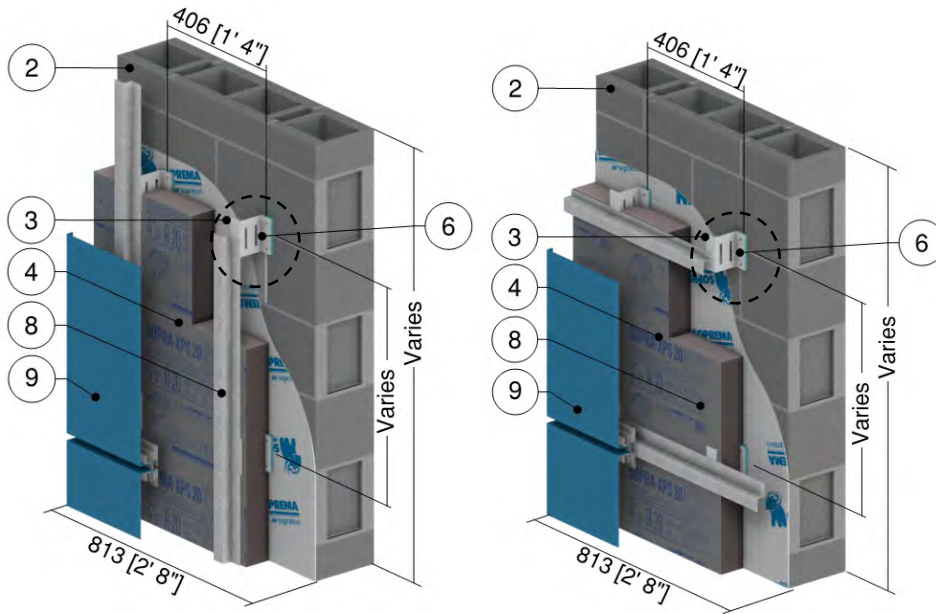

Vertical Girt: ACS Clip Detail

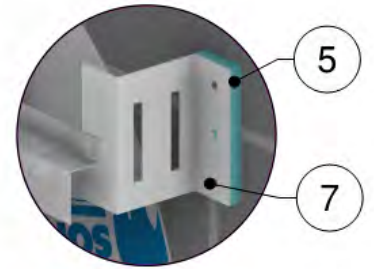

Horizontal Girt: ACS Clip Detail

ID	Component	Thickness Inches (mm)	Conductivity Btu-in / ft ² ·hr·°F (W/m K)	Nominal Resistance hr·ft ² ·°F/Btu (m ² K/W)	Density lb/ft ³ (kg/m ³)	Specific Heat Btu/lb·°F (J/kg K)
1	Interior Film ¹	-	-	R-0.7 (0.12 RSI)	-	-
2	Standard Concrete Blocks	8" (203)	10.4 (1.50)	-	119 (1900)	0.19 (800)
3	SOPREMA SOPRASEAL STICK 1100T membrane installed with SOPRASEAL STICK PRIMER	-	-	-	-	-
4	SOPRA-XPS 20 Exterior Insulation	Varies	0.20 (0.029)	R-15.0 to R-35.0 (2.64 RSI to 6.16 RSI)	2.5 (40)	0.29 (1220)
5	Thermal Break	1/2" (13)	0.13 (0.019)	-	2.1 (33)	0.50 (2100)
6	ACS-S Thermal Clip	16 Gauge	118 (17)	-	500 (8000)	0.13 (530)
7	Fastener	1/4" (6.4) Ø	347 (50)	-	489 (7830)	0.12 (500)
8	Girt	18 Gauge	430 (62)	-	489 (7830)	0.12 (500)
9	Cladding with 1/2" vented airspace incorporated into exterior heat transfer coefficient					
10	Exterior Film ¹	-	-	R-0.7 (0.12 RSI)	-	-

¹ Value selected from table 1, p. 26.1 of 2009 ASHRAE Handbook – Fundamentals depending on surface orientation

Detail 7.1.18

Exterior Insulated Concrete Block Wall Assembly with SOPREMA SOPRA-XPS 20 and ACS-S Thermal Clip (24" o.c. Horizontal) Supporting Metal Cladding - Clear Wall

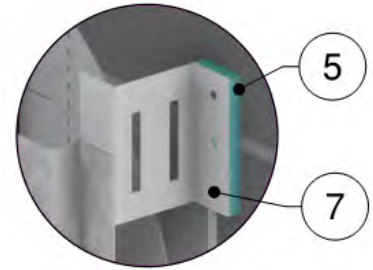
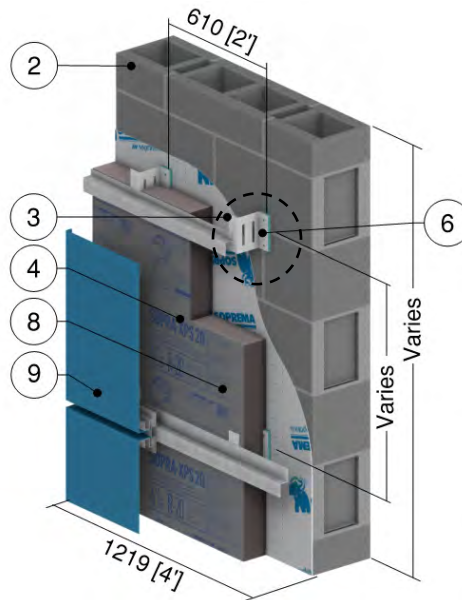
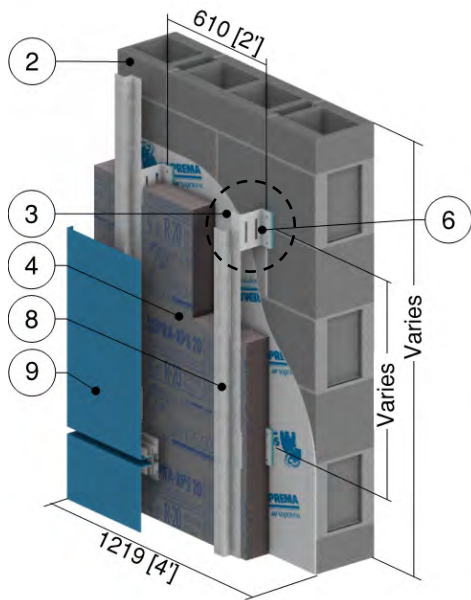

Vertical Girt: ACS Clip Detail

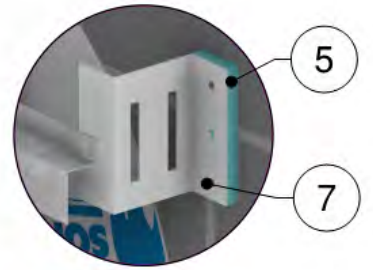

Horizontal Girt: ACS Clip Detail

ID	Component	Thickness Inches (mm)	Conductivity Btu-in / ft ² ·hr·°F (W/m K)	Nominal Resistance hr·ft ² ·°F/Btu (m ² K/W)	Density lb/ft ³ (kg/m ³)	Specific Heat Btu/lb·°F (J/kg K)
1	Interior Film ¹	-	-	R-0.7 (0.12 RSI)	-	-
2	Standard Concrete Blocks	8" (203)	10.4 (1.50)	-	119 (1900)	0.19 (800)
3	SOPREMA SOPRASEAL STICK 1100T membrane installed with SOPRASEAL STICK PRIMER	-	-	-	-	-
4	SOPRA-XPS 20 Exterior Insulation	Varies	0.20 (0.029)	R-15.0 to R-35.0 (2.64 RSI to 6.16 RSI)	2.5 (40)	0.29 (1220)
5	Thermal Break	1/2" (13)	0.13 (0.019)	-	2.1 (33)	0.50 (2100)
6	ACS-S Thermal Clip	16 Gauge	118 (17)	-	500 (8000)	0.13 (530)
7	Fastener	1/4" (6.4) Ø	347 (50)	-	489 (7830)	0.12 (500)
8	Girt	18 Gauge	430 (62)	-	489 (7830)	0.12 (500)
9	Cladding with 1/2" vented airspace incorporated into exterior heat transfer coefficient					
10	Exterior Film ¹	-	-	R-0.7 (0.12 RSI)	-	-

¹ Value selected from table 1, p. 26.1 of 2009 ASHRAE Handbook – Fundamentals depending on surface orientation

Detail 7.1.19

Exterior Insulated Concrete Block Wall Assembly with SOPREMA SOPRA-SPF 202 and ACS-S Thermal Clip (16" o.c. Horizontal) Supporting Metal Cladding - Clear Wall

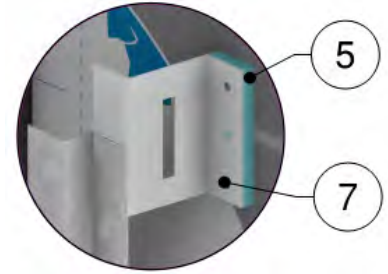
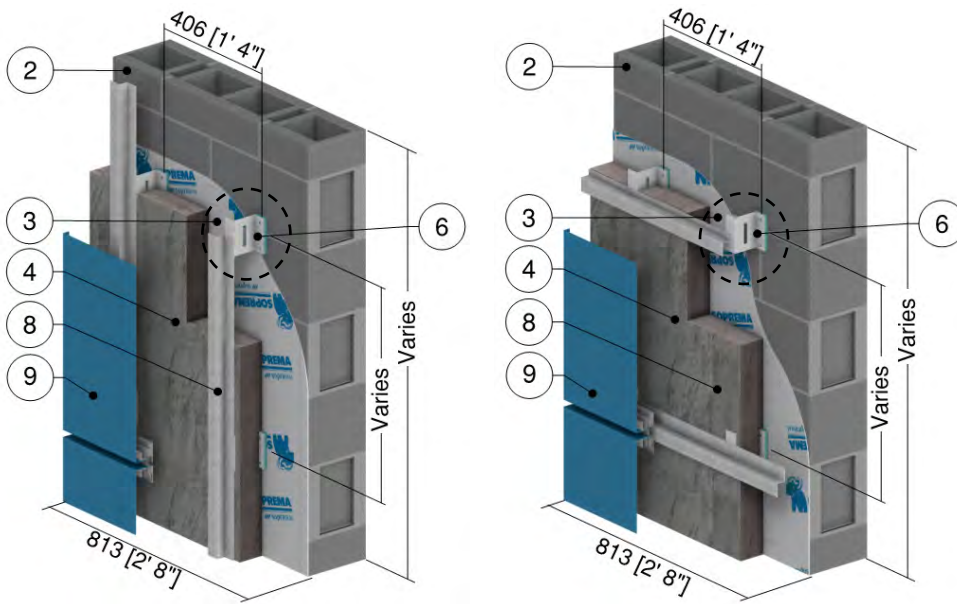

Vertical Girt: ACS Clip Detail

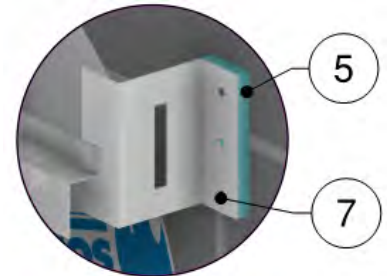

Horizontal Girt: ACS Clip Detail

ID	Component	Thickness Inches (mm)	Conductivity Btu-in / ft ² -hr-°F (W/m K)	Nominal Resistance hr-ft ² -°F/Btu (m ² K/W)	Density lb/ft ³ (kg/m ³)	Specific Heat Btu/lb-°F (J/kg K)
1	Interior Film ¹	-	-	R-0.7 (0.12 RSI)	-	-
2	Standard Concrete Blocks	8" (203)	10.4 (1.50)	-	119 (1900)	0.19 (800)
3	SOPREMA SOPRASEAL STICK 1100T membrane installed with SOPRASEAL STICK PRIMER	-	-	-	-	-
4	SOPRA-SPF 202 Exterior Insulation	Varies	0.16 (0.023)	R-6.2 to R-37.2 (1.09 RSI to 6.55 RSI)	1.8 (28)	0.29 (1220)
5	Thermal Break	1/2" (13)	0.13 (0.019)	-	2.1 (33)	0.50 (2100)
6	ACS-S Thermal Clip	16 Gauge	118 (17)	-	500 (8000)	0.13 (530)
7	Fastener	1/4" (6.4) Ø	347 (50)	-	489 (7830)	0.12 (500)
8	Girt	18 Gauge	430 (62)	-	489 (7830)	0.12 (500)
9	Cladding with 1/2" vented airspace incorporated into exterior heat transfer coefficient					
10	Exterior Film ¹	-	-	R-0.7 (0.12 RSI)	-	-

¹ Value selected from table 1, p. 26.1 of 2009 ASHRAE Handbook – Fundamentals depending on surface orientation

Detail 7.1.20

Exterior Insulated Concrete Block Wall Assembly with SOPREMA SOPRA-SPF 202 and ACS-S Thermal Clip (24" o.c. Horizontal) Supporting Metal Cladding - Clear Wall

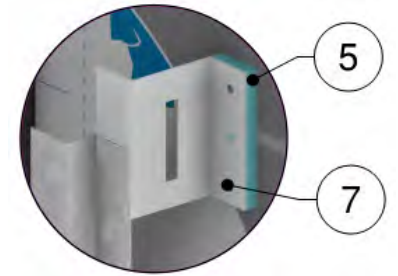
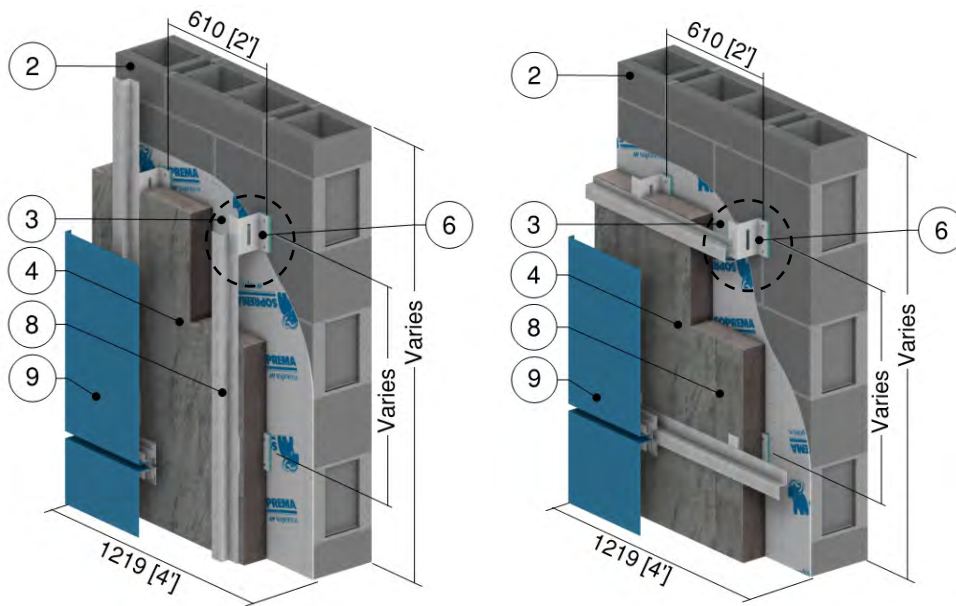

Vertical Girt: ACS Clip Detail

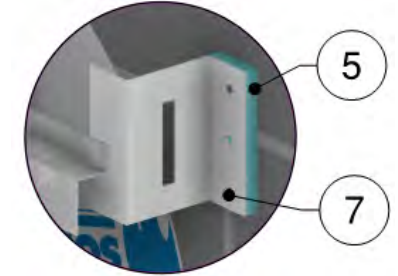

Horizontal Girt: ACS Clip Detail

ID	Component	Thickness Inches (mm)	Conductivity Btu-in / ft ² ·hr·°F (W/m K)	Nominal Resistance hr·ft ² ·°F/Btu (m ² K/W)	Density lb/ft ³ (kg/m ³)	Specific Heat Btu/lb·°F (J/kg K)
1	Interior Film ¹	-	-	R-0.7 (0.12 RSI)	-	-
2	Standard Concrete Blocks	8" (203)	10.4 (1.50)	-	119 (1900)	0.19 (800)
3	SOPREMA SOPRASEAL STICK 1100T membrane installed with SOPRASEAL STICK PRIMER	-	-	-	-	-
4	SOPRA-SPF 202 Exterior Insulation	Varies	0.16 (0.023)	R-6.2 to R-37.2 (1.09 RSI to 6.55 RSI)	1.8 (28)	0.29 (1220)
5	Thermal Break	1/2" (13)	0.13 (0.019)	-	2.1 (33)	0.50 (2100)
6	ACS-S Thermal Clip	16 Gauge	118 (17)	-	500 (8000)	0.13 (530)
7	Fastener	1/4" (6.4) Ø	347 (50)	-	489 (7830)	0.12 (500)
8	Girt	18 Gauge	430 (62)	-	489 (7830)	0.12 (500)
9	Cladding with 1/2" vented airspace incorporated into exterior heat transfer coefficient					
10	Exterior Film ¹	-	-	R-0.7 (0.12 RSI)	-	-

¹ Value selected from table 1, p. 26.1 of 2009 ASHRAE Handbook – Fundamentals depending on surface orientation

Detail 7.1.21

Exterior Insulated Concrete Block Wall Assembly with SOPREMA SOPRA-ISO V ALU and ACS-S Thermal Clip (16" o.c. Horizontal) Supporting Metal Cladding - Clear Wall

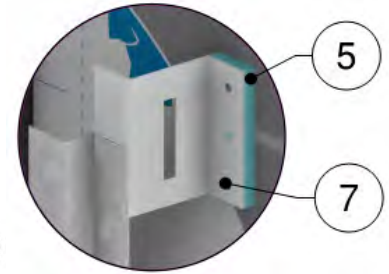
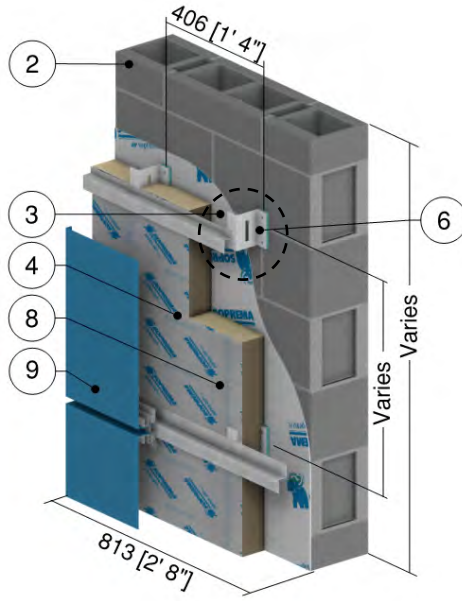
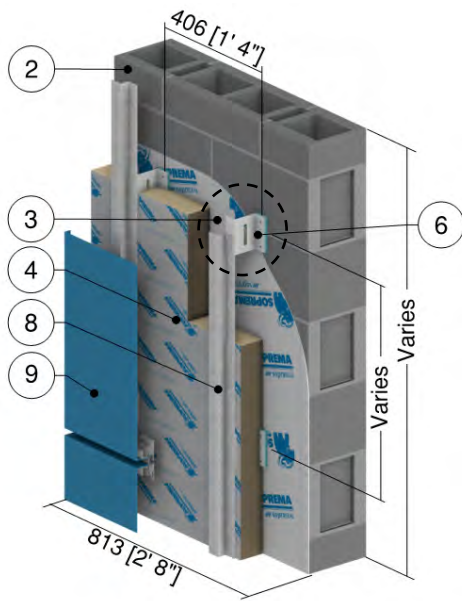

Vertical Girt: ACS Clip Detail

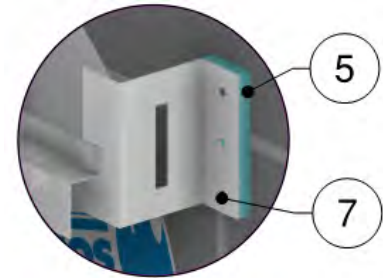

Horizontal Girt: ACS Clip Detail

ID	Component	Thickness Inches (mm)	Conductivity Btu-in / ft ² -hr-°F (W/m K)	Nominal Resistance hr-ft ² -°F/Btu (m ² K/W)	Density lb/ft ³ (kg/m ³)	Specific Heat Btu/lb-°F (J/kg K)
1	Interior Film ¹	-	-	R-0.7 (0.12 RSI)	-	-
2	Standard Concrete Blocks	8" (203)	10.4 (1.50)	-	119 (1900)	0.19 (800)
3	SOPREMA SOPRASEAL STICK 1100T membrane installed with SOPRASEAL STICK PRIMER	-	-	-	-	-
4	SOPRA-ISO V ALU Exterior Insulation	Varies	0.15 (0.022)	R-6.5 to R-39.0 (1.14 RSI to 6.87 RSI)	1.9 (30)	0.36 (1500)
5	Thermal Break	1/2" (13)	0.13 (0.019)	-	2.1 (33)	0.50 (2100)
6	ACS-S Thermal Clip	16 Gauge	118 (17)	-	500 (8000)	0.13 (530)
7	Fastener	1/4" (6.4) Ø	347 (50)	-	489 (7830)	0.12 (500)
8	Girt	18 Gauge	430 (62)	-	489 (7830)	0.12 (500)
9	Cladding with 1/2" vented airspace incorporated into exterior heat transfer coefficient					
10	Exterior Film ¹	-	-	R-0.7 (0.12 RSI)	-	-

¹ Value selected from table 1, p. 26.1 of 2009 ASHRAE Handbook – Fundamentals depending on surface orientation

Detail 7.1.22

Exterior Insulated Concrete Block Wall Assembly with SOPREMA SOPRA-ISO V ALU and ACS-S Thermal Clip (24" o.c. Horizontal) Supporting Metal Cladding - Clear Wall

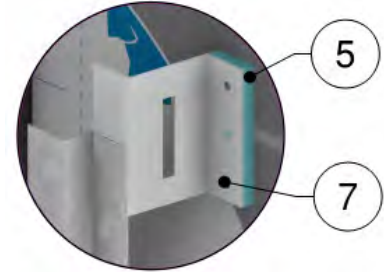
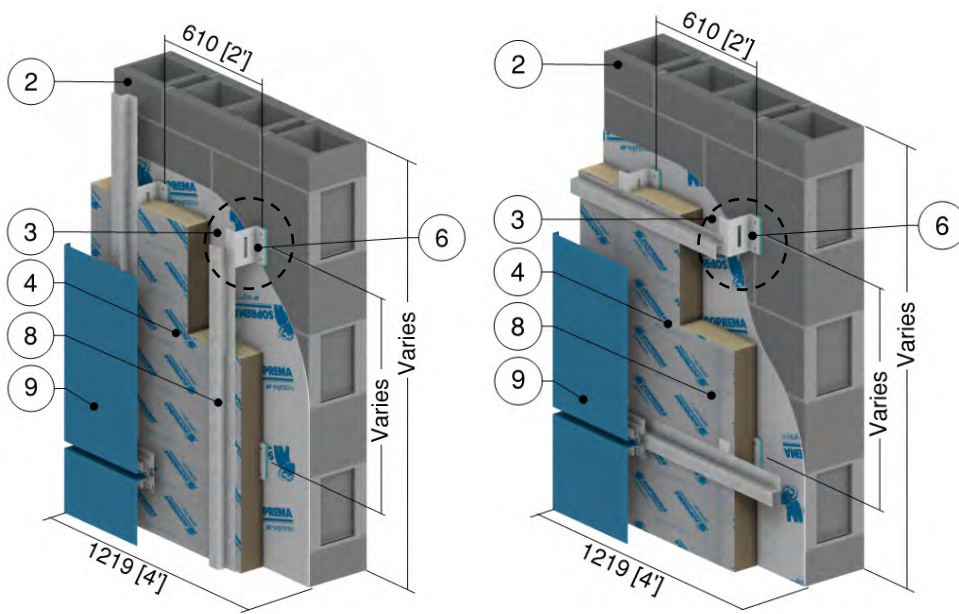

Vertical Girt: ACS Clip Detail

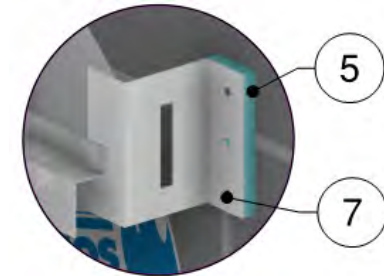

Horizontal Girt: ACS Clip Detail

ID	Component	Thickness Inches (mm)	Conductivity Btu-in / ft ² -hr-°F (W/m K)	Nominal Resistance hr-ft ² -°F/Btu (m ² K/W)	Density lb/ft ³ (kg/m ³)	Specific Heat Btu/lb-°F (J/kg K)
1	Interior Film ¹	-	-	R-0.7 (0.12 RSI)	-	-
2	Standard Concrete Blocks	8" (203)	10.4 (1.50)	-	119 (1900)	0.19 (800)
3	SOPREMA SOPRASEAL STICK 1100T membrane installed with SOPRASEAL STICK PRIMER	-	-	-	-	-
4	SOPRA-ISO V ALU Exterior Insulation	Varies	0.15 (0.022)	R-6.5 to R-39.0 (1.14 RSI to 6.87 RSI)	1.9 (30)	0.36 (1500)
5	Thermal Break	1/2" (13)	0.13 (0.019)	-	2.1 (33)	0.50 (2100)
6	ACS-S Thermal Clip	16 Gauge	118 (17)	-	500 (8000)	0.13 (530)
7	Fastener	1/4" (6.4) Ø	347 (50)	-	489 (7830)	0.12 (500)
8	Girt	18 Gauge	430 (62)	-	489 (7830)	0.12 (500)
9	Cladding with 1/2" vented airspace incorporated into exterior heat transfer coefficient					
10	Exterior Film ¹	-	-	R-0.7 (0.12 RSI)	-	-

¹ Value selected from table 1, p. 26.1 of 2009 ASHRAE Handbook – Fundamentals depending on surface orientation

Detail 7.1.23

Exterior Insulated Concrete Block Wall Assembly with Mineral Wool and ACS-S Thermal Clip (16" o.c. Horizontal) Supporting Metal Cladding - Clear Wall

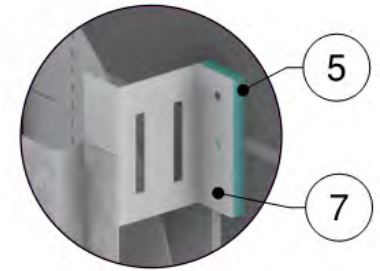
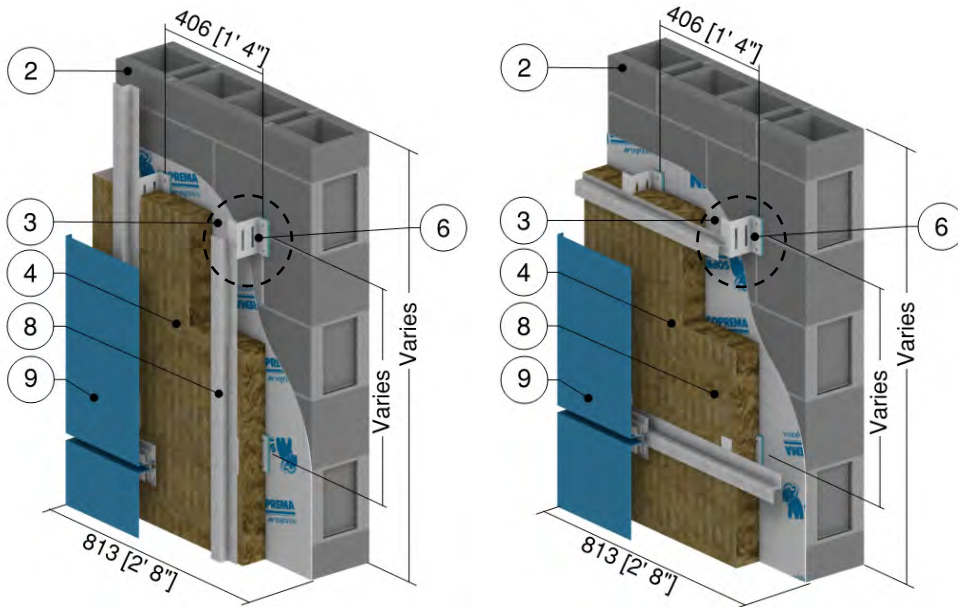

Vertical Girt: ACS Clip Detail

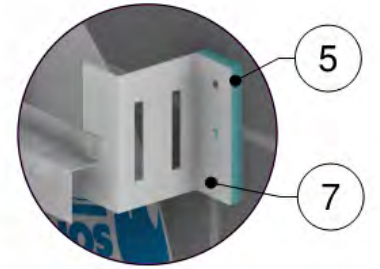

Horizontal Girt: ACS Clip Detail

ID	Component	Thickness Inches (mm)	Conductivity Btu-in / ft ² -hr-°F (W/m K)	Nominal Resistance hr-ft ² -°F/Btu (m ² K/W)	Density lb/ft ³ (kg/m ³)	Specific Heat Btu/lb-°F (J/kg K)
1	Interior Film ¹	-	-	R-0.7 (0.12 RSI)	-	-
2	Standard Concrete Blocks	8" (203)	10.4 (1.50)	-	119 (1900)	0.19 (800)
3	SOPREMA SOPRASEAL STICK 1100T membrane installed with SOPRASEAL STICK PRIMER	-	-	-	-	-
4	Exterior Mineral Wool Insulation	Varies	0.23 (0.034)	R-12.9 to R-34.4 (2.27 RSI to 6.06 RSI)	1.8 (28)	0.29 (1220)
5	Thermal Break	1/2" (13)	0.13 (0.019)	-	2.1 (33)	0.50 (2100)
6	ACS-S Thermal Clip	16 Gauge	118 (17)	-	500 (8000)	0.13 (530)
7	Fastener	1/4" (6.4) Ø	347 (50)	-	489 (7830)	0.12 (500)
8	Girt	18 Gauge	430 (62)	-	489 (7830)	0.12 (500)
9	Cladding with 1/2" vented airspace incorporated into exterior heat transfer coefficient					
10	Exterior Film ¹	-	-	R-0.7 (0.12 RSI)	-	-

¹ Value selected from table 1, p. 26.1 of 2009 ASHRAE Handbook – Fundamentals depending on surface orientation

Detail 7.1.24

Exterior Insulated Concrete Block Wall Assembly with Mineral Wool and ACS-S Thermal Clip (24" o.c. Horizontal) Supporting Metal Cladding - Clear Wall

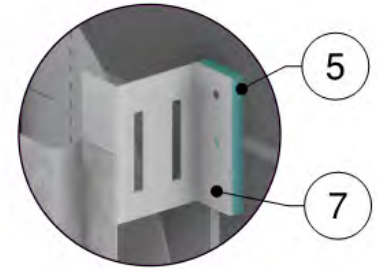
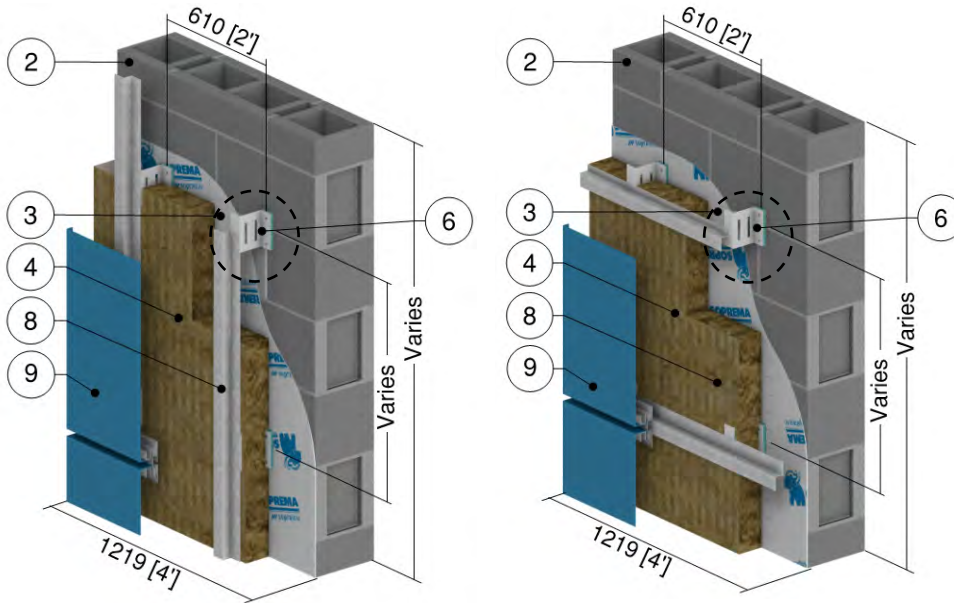

Vertical Girt: ACS Clip Detail

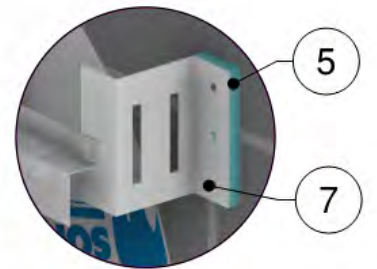

Horizontal Girt: ACS Clip Detail

ID	Component	Thickness Inches (mm)	Conductivity Btu-in / ft ² ·hr·°F (W/m K)	Nominal Resistance hr·ft ² ·°F/Btu (m ² K/W)	Density lb/ft ³ (kg/m ³)	Specific Heat Btu/lb·°F (J/kg K)
1	Interior Film ¹	-	-	R-0.7 (0.12 RSI)	-	-
2	Standard Concrete Blocks	8" (203)	10.4 (1.50)	-	119 (1900)	0.19 (800)
3	SOPREMA SOPRASEAL STICK 1100T membrane installed with SOPRASEAL STICK PRIMER	-	-	-	-	-
4	Exterior Mineral Wool Insulation	Varies	0.23 (0.034)	R-12.9 to R-34.4 (2.27 RSI to 6.06 RSI)	1.8 (28)	0.29 (1220)
5	Thermal Break	1/2" (13)	0.13 (0.019)	-	2.1 (33)	0.50 (2100)
6	ACS-S Thermal Clip	16 Gauge	118 (17)	-	500 (8000)	0.13 (530)
7	Fastener	1/4" (6.4) Ø	347 (50)	-	489 (7830)	0.12 (500)
8	Girt	18 Gauge	430 (62)	-	489 (7830)	0.12 (500)
9	Cladding with 1/2" vented airspace incorporated into exterior heat transfer coefficient					
10	Exterior Film ¹	-	-	R-0.7 (0.12 RSI)	-	-

¹ Value selected from table 1, p. 26.1 of 2009 ASHRAE Handbook – Fundamentals depending on surface orientation

Detail 7.1.25

Exterior Insulated Concrete Block Wall Assembly with Protected SOPREMA SOPRA-ISO V ALU and ACS-S Thermal Clip (16" o.c. Horizontal) Supporting Metal Cladding - Clear Wall

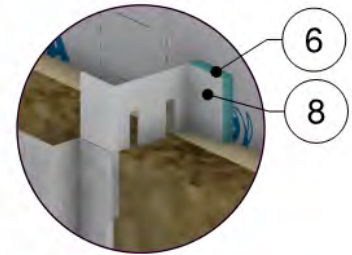
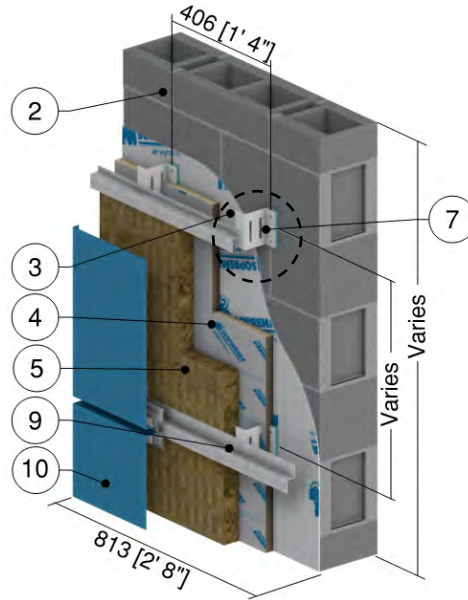
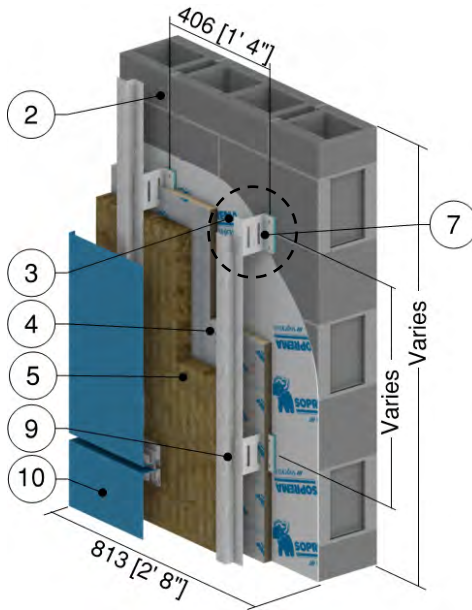

Vertical Girt: ACS Clip Detail

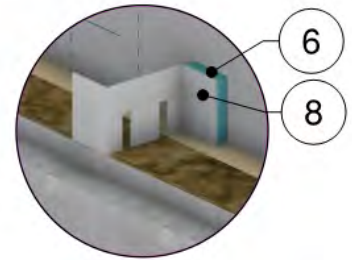

Horizontal Girt: ACS Clip Detail

ID	Component	Thickness Inches (mm)	Conductivity Btu·in / ft ² ·hr·°F (W/m K)	Nominal Resistance hr·ft ² ·°F/Btu (m ² K/W)	Density lb/ft ³ (kg/m ³)	Specific Heat Btu/lb·°F (J/kg K)
1	Interior Film ¹	-	-	R-0.7 (0.12 RSI)	-	-
2	Standard Concrete Blocks	8" (203)	10.4 (1.50)	-	119 (1900)	0.19 (800)
3	SOPREMA SOPRASEAL STICK 1100T membrane installed with SOPRASEAL STICK PRIMER	-	-	-	-	-
4	SOPRA-ISO V ALU Exterior Insulation	Varies	0.15 (0.022)	R-6.5 to R-32.5 (1.14 RSI to 5.72 RSI)	1.9 (30)	0.36 (1500)
5	Exterior Mineral Wool Insulation	2" (50)	0.23 (0.034)	R-8.6 (1.51 RSI)	1.8 (28)	0.29 (1220)
6	Thermal Break	1/2" (13)	0.13 (0.019)	-	2.1 (33)	0.50 (2100)
7	ACS-S Thermal Clip	16 Gauge	118 (17)	-	500 (8000)	0.13 (530)
8	Fastener	1/4" (6.4) Ø	347 (50)	-	489 (7830)	0.12 (500)
9	Girt	18 Gauge	430 (62)	-	489 (7830)	0.12 (500)
10	Cladding with 1/2" vented airspace incorporated into exterior heat transfer coefficient					
11	Exterior Film ¹	-	-	R-0.7 (0.12 RSI)	-	-

¹ Value selected from table 1, p. 26.1 of 2009 ASHRAE Handbook – Fundamentals depending on surface orientation

Detail 7.1.26

Exterior Insulated Concrete Block Wall Assembly with Protected SOPREMA SOPRA-ISO V ALU and ACS-S Thermal Clip (24" o.c. Horizontal) Supporting Metal Cladding - Clear Wall

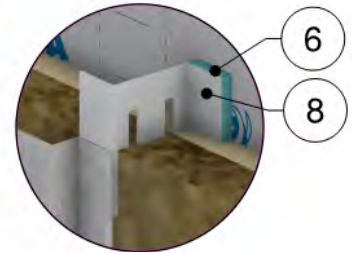
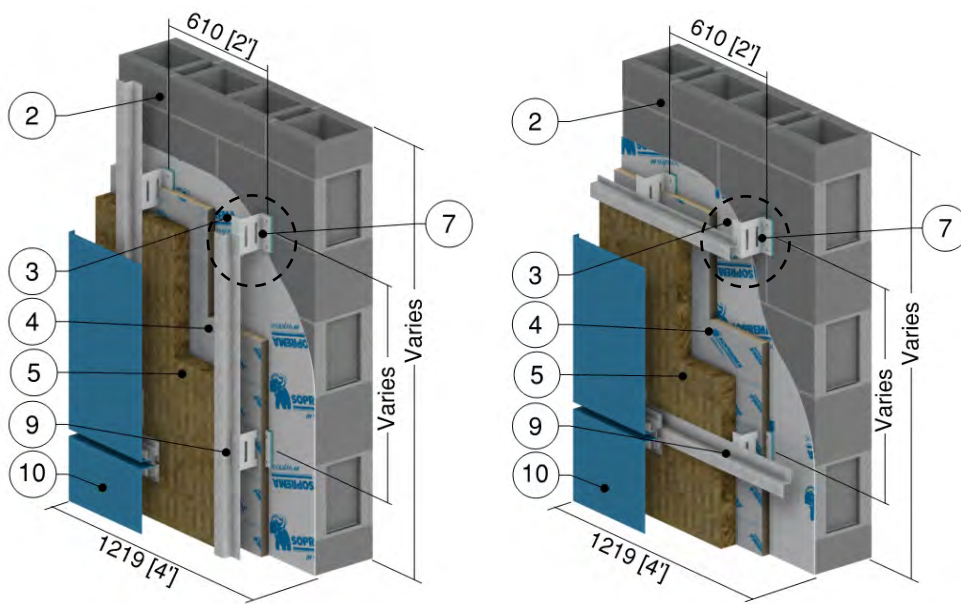

Vertical Girt: ACS Clip Detail

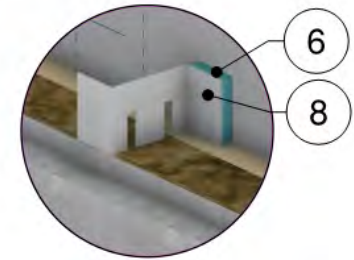

Horizontal Girt: ACS Clip Detail

ID	Component	Thickness Inches (mm)	Conductivity Btu-in / ft ² -hr-°F (W/m K)	Nominal Resistance hr-ft ² -°F/Btu (m ² K/W)	Density lb/ft ³ (kg/m ³)	Specific Heat Btu/lb-°F (J/kg K)
1	Interior Film ¹	-	-	R-0.7 (0.12 RSI)	-	-
2	Standard Concrete Blocks	8" (203)	10.4 (1.50)	-	119 (1900)	0.19 (800)
3	SOPREMA SOPRASEAL STICK 1100T membrane installed with SOPRASEAL STICK PRIMER	-	-	-	-	-
4	SOPRA-ISO V ALU Exterior Insulation	Varies	0.15 (0.022)	R-6.5 to R-32.5 (1.14 RSI to 5.72 RSI)	1.9 (30)	0.36 (1500)
5	Exterior Mineral Wool Insulation	2" (50)	0.23 (0.034)	R-8.6 (1.51 RSI)	1.8 (28)	0.29 (1220)
6	Thermal Break	1/2" (13)	0.13 (0.019)	-	2.1 (33)	0.50 (2100)
7	ACS-S Thermal Clip	16 Gauge	118 (17)	-	500 (8000)	0.13 (530)
8	Fastener	1/4" (6.4) Ø	347 (50)	-	489 (7830)	0.12 (500)
9	Girt	18 Gauge	430 (62)	-	489 (7830)	0.12 (500)
10	Cladding with 1/2" vented airspace incorporated into exterior heat transfer coefficient					
11	Exterior Film ¹	-	-	R-0.7 (0.12 RSI)	-	-

¹ Value selected from table 1, p. 26.1 of 2009 ASHRAE Handbook – Fundamentals depending on surface orientation

Detail 7.1.27

Exterior Insulated Concrete Mass Wall with 1 5/8" x 1 5/8" Steel Stud (16" o.c.) and Thermally Isolated Vertical Brackets and Rail System (24" o.c.) Supporting Metal Cladding – Clear Wall

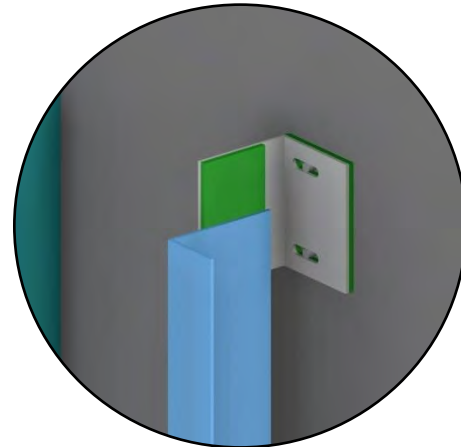
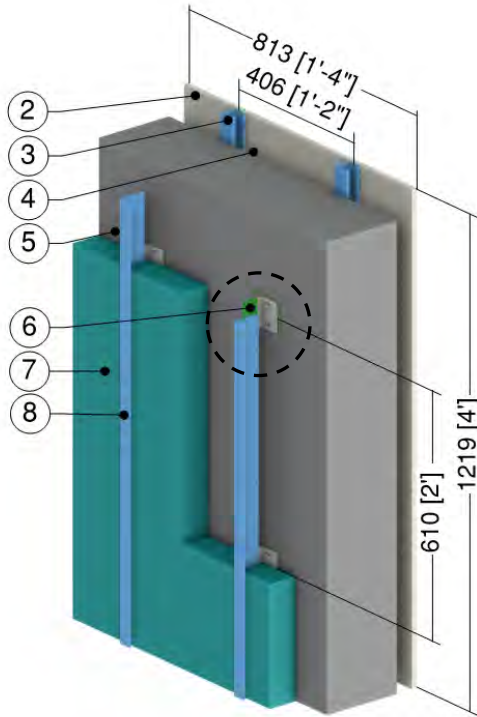

Clip Detail

ID	Component	Thickness Inches (mm)	Conductivity Btu·in / ft ² ·hr·°F (W/m K)	Nominal Resistance hr·ft ² ·°F/Btu (m ² K/W)	Density lb/ft ³ (kg/m ³)	Specific Heat Btu/lb·°F (J/kg K)
1	Interior Film ¹	-	-	R-0.7 (0.12 RSI)	-	-
2	Gypsum Board	1/2" (13)	1.1 (0.16)	R-0.5 (0.08 RSI)	50 (800)	0.26 (1090)
3	1 5/8" x 1 5/8" Steel Studs (16" o.c.) with Top and Bottom Tracks	20 Gauge	430 (62)	-	489 (7830)	0.12 (500)
4	Air in Stud Cavity	1 5/8" (41)	-	R-0.9 (0.16 RSI)	0.075 (1.2)	0.24 (1000)
5	Concrete Wall	8" (203)	12.5 (1.8)	-	140 (2250)	0.20 (850)
6	Thermally Isolated Aluminum Bracket	0.09" (2.2)	1109 (160)	-	171 (2739)	0.21 (900)
7	Exterior Insulation	Varies	-	R-10 to R-25 (1.76 RSI to 4.40 RSI)	1.8 (28)	0.29 (1220)
8	Vertical Aluminum L-girt	0.09" (2.2)	1109 (160)	-	171 (2739)	0.21 (900)
9	Generic Cladding with 1/2" (13mm) vented air space is incorporated into exterior heat transfer coefficient					
10	Exterior Film ¹	-	-	R-0.7 (0.12 RSI)	-	-

¹ Value selected from table 1, p. 26.1 of 2009 ASHRAE Handbook – Fundamentals depending on surface orientation

Detail 7.2.1

Exterior Insulated Concrete Drained EIFS Wall Assembly – Intermediate Floor Intersection

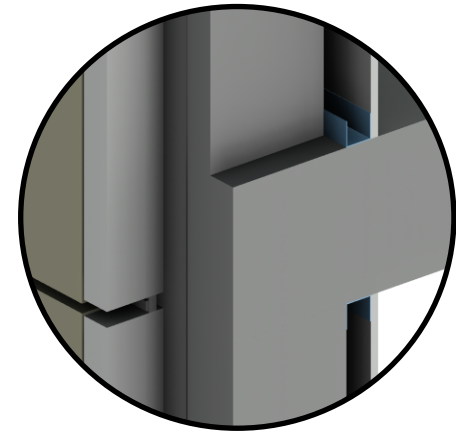
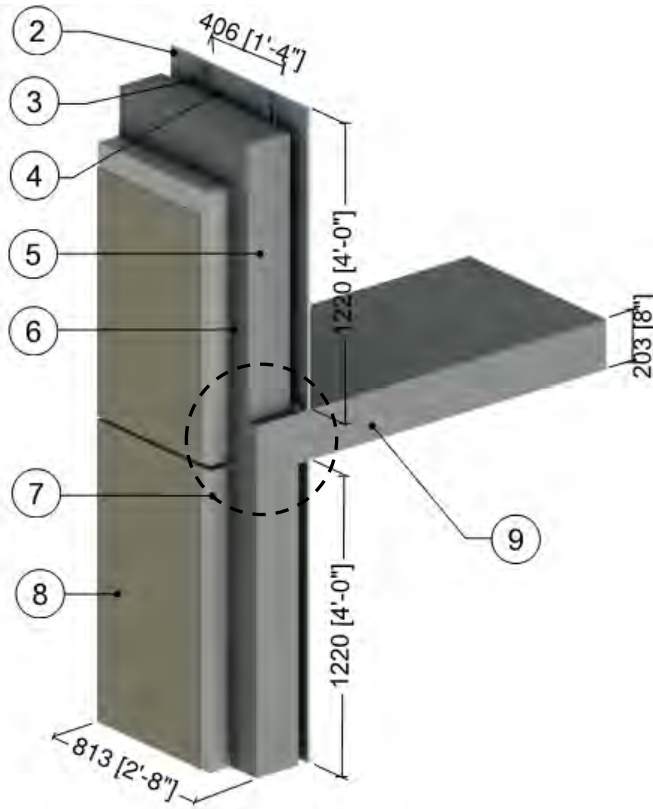

1" (25 mm)
Drained EIFS
at Slab Detail

ID	Component	Thickness Inches (mm)	Conductivity Btu-in / ft ² -hr-°F (W/m K)	Nominal Resistance hr-ft ² -°F/Btu (m ² K/W)	Density lb/ft ³ (kg/m ³)	Specific Heat Btu/lb-°F (J/kg K)
1	Interior Films ¹	-	-	R-0.6 to R-0.9 (0.11 RSI to 0.16 RSI)	-	-
2	Gypsum Board	1/2" (13)	1.1 (0.16)	R-0.5 (0.08 RSI)	50 (800)	0.26 (1090)
3	1 5/8" x 1 5/8" Steel Studs (16"o.c.) with Top and Bottom Tracks	18 Gauge	430 (62)	-	489 (7830)	0.12 (500)
4	Air in Stud Cavity	1 5/8" (41)	-	R-0.9 (0.16 RSI)	0.075 (1.2)	0.24 (1000)
5	Concrete Wall	8" (203)	12 (1.8)	-	140 (2250)	0.20 (850)
6	Weather Resistive Barrier with Adhesive	-	-	-	-	-
7	Insulation Board	4" (100)	0.27 (0.039)	R-15 (2.64 RSI)	1 (16)	0.35 (1470)
8	Lamina	1/8" (4)	6 (0.9)	R-0.04 (0.01 RSI)	120 (1922)	0.20 (850)
9	Concrete Slab	8" (203)	12.5 (1.8)	-	140 (2250)	0.20 (850)
10	Exterior Film ¹	-	-	R-0.2 (0.03 RSI)	-	-

¹ Value selected from table 1, p. 26.1 of 2009 ASHRAE Handbook – Fundamentals depending on surface orientation

Detail 7.2.2

Interior Insulated Concrete Mass Wall with 1 5/8" Steel Stud (16"o.c.) Supporting Interior Finish – Non-Insulated Interior Wall and Non-insulated Intermediate Floor Intersection

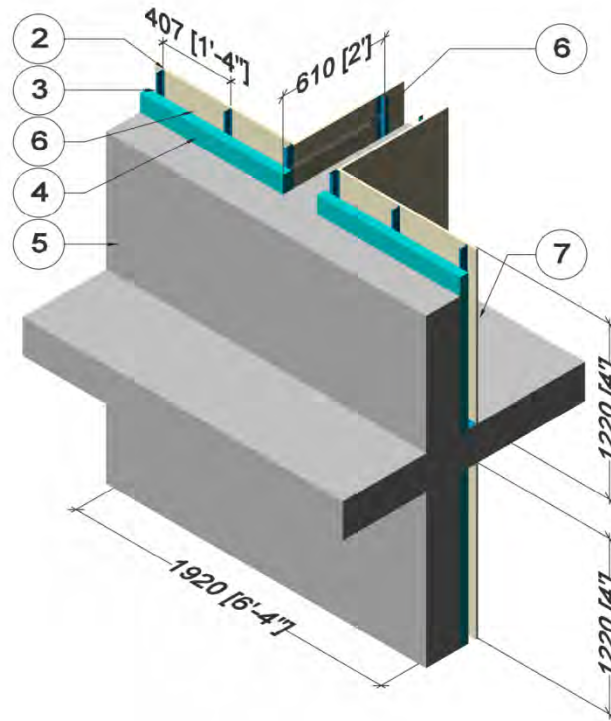

ID	Component	Thickness Inches (mm)	Conductivity Btu-in / ft ² ·hr·°F (W/m K)	Nominal Resistance hr·ft ² ·°F/Btu (m ² K/W)	Density lb/ft ³ (kg/m ³)	Specific Heat Btu/lb·°F (J/kg K)
1	Interior Film ¹	-	-	R-0.6 to R-0.9 (0.11 RSI to 0.16 RSI)	-	-
2	Gypsum Board	1/2" (13)	1.1 (0.16)	R-0.5 (0.08 RSI)	50 (800)	0.26 (1090)
3	1 5/8" Steel Studs with Metal Tracks	20 Gauge	430 (62)	-	489 (7830)	0.12 (500)
4	Interior Insulation	2" (51)	0.2 (0.03)	R-11 (1.9 RSI)	1.8 (28)	0.29 (1220)
5	Exterior Concrete Mass Wall	8" (203)	12.5 (1.8)	-	140 (2250)	0.20 (850)
6	Air in Stud Cavity and Interior Partition	Varies	-	R-0.9 (0.16 RSI)	0.075 (1.2)	0.24 (1000)
7	Concrete Slab, Floor & Balcony	8" (203)	12.5 (1.8)	-	140 (2250)	0.20 (850)
8	Exterior Film ¹	-	-	R-0.2 (0.03 RSI)	-	-

¹ Value selected from table 1, p. 26.1 of 2009 ASHRAE Handbook – Fundamentals depending on surface orientation

Detail 7.2.3

Interior Insulated Concrete Mass Wall with 1 5/8" Steel Stud (16" o.c.) Supporting Interior Finish – Insulated Interior Wall and Non-insulated Intermediate Floor Intersection

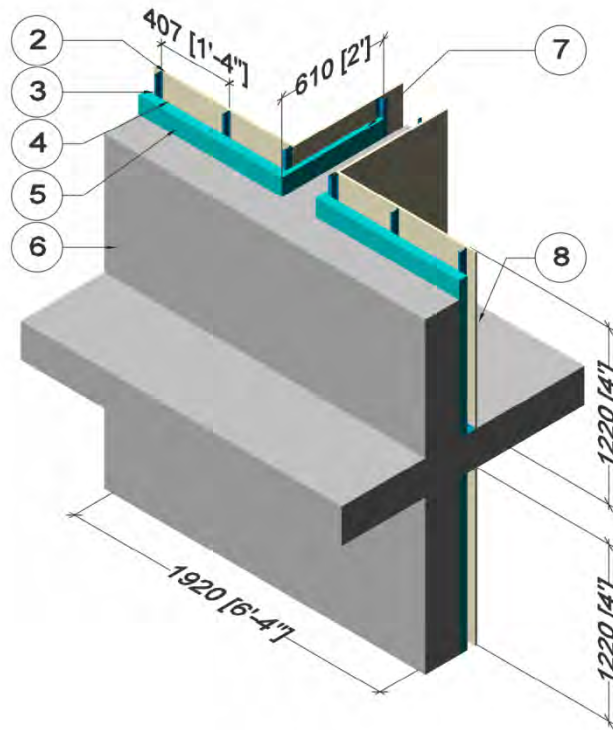

ID	Component	Thickness Inches (mm)	Conductivity Btu-in / ft ² ·hr·°F (W/m K)	Nominal Resistance hr·ft ² ·°F/Btu (m ² K/W)	Density lb/ft ³ (kg/m ³)	Specific Heat Btu/lb·°F (J/kg K)
1	Interior Film ¹	-	-	R-0.6 to R-0.9 (0.11 RSI to 0.16 RSI)	-	-
2	Gypsum Board	1/2" (13)	1.1 (0.16)	R-0.5 (0.08 RSI)	50 (800)	0.26 (1090)
3	1 5/8" Steel Studs with Top and Bottom Tracks	20 Gauge	430 (62)	-	489 (7830)	0.12 (500)
4	Air in Stud Cavity	1 5/8" (41)	-	R-0.9 (0.16 RSI)	0.075 (1.2)	0.24 (1000)
5	Interior Insulation	2" (51)	0.2 (0.03)	R-11 (1.9 RSI)	1.8 (28)	0.29 (1220)
6	Exterior Concrete Mass Wall	8" (203)	12.5 (1.8)	-	140 (2250)	0.20 (850)
7	Interior Partition Insulation	1" (25)	-	R-5 (0.88 RSI)	1.8 (28)	0.29 (1220)
8	Concrete Slab, Floor & Balcony	8" (203)	12.5 (1.8)	-	140 (2250)	0.20 (850)
9	Exterior Film ¹	-	-	R-0.2 (0.03 RSI)	-	-

¹ Value selected from table 1, p. 26.1 of 2009 ASHRAE Handbook – Fundamentals depending on surface orientation

Detail 7.2.4

Interior Insulated Concrete Mass Wall with 3 5/8" x 1 5/8" Steel Studs (16" o.c.) Supporting Interior Finish – Interior Insulated Wall and Non-Insulated Partition Wall Intersection

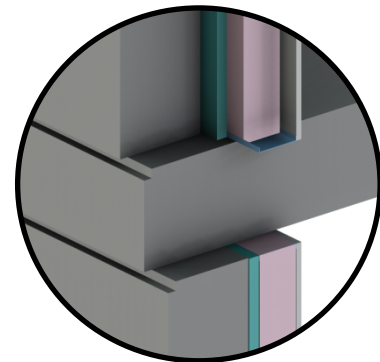
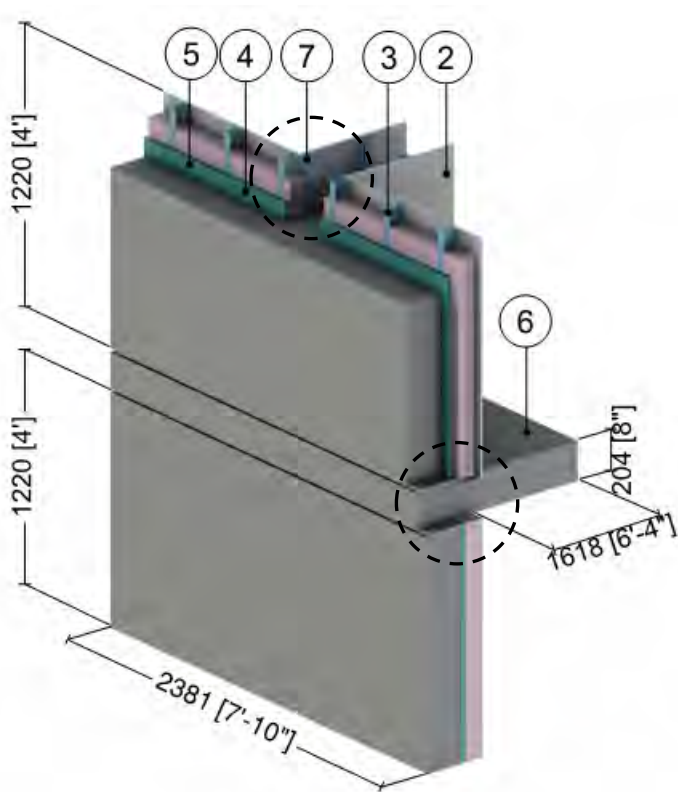

Slab Edge Detail

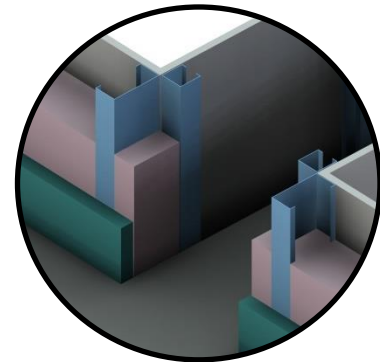

Partition Detail

ID	Component	Thickness Inches (mm)	Conductivity Btu-in / ft ² ·hr·°F (W/m K)	Nominal Resistance hr·ft ² ·°F/Btu (m ² K/W)	Density lb/ft ³ (kg/m ³)	Specific Heat Btu/lb·°F (J/kg K)
1	Interior Film ¹	-	-	R-0.6 to R-0.9 (0.11 RSI to 0.16 RSI)	-	-
2	Gypsum Board	1/2" (13)	1.1 (0.16)	R-0.5 (0.08 RSI)	50 (800)	0.26 (1090)
3	3 5/8" x 1 5/8" Steel Studs with Top and Bottom Tracks	18 Gauge	430 (62)	-	489 (7830)	0.12 (500)
4	Fiberglass Batt Insulation	3 5/8" (92)	0.29 (0.042)	R-12 (2.1 RSI)	0.9 (14)	0.17 (710)
5	Continuous Insulation	Varies	-	R-10 to R-15 (1.76 RSI to 2.64 RSI)	1.8 (28)	0.29 (1220)
6	Concrete Wall/Floor Slab	8" (203)	12.5 (1.8)	-	140 (2250)	0.20 (850)
7	1 5/8" x 1 5/8" Steel Studs with Top and Bottom Tracks	18 Gauge	430 (62)	-	489 (7830)	0.12 (500)
8	Exterior Film ¹	-	-	R-0.2 (0.03 RSI)	-	-

¹ Value selected from table 1, p. 26.1 of 2009 ASHRAE Handbook – Fundamentals depending on surface orientation

Detail 7.2.5

Interior Insulated Concrete Mass Wall with 1 5/8" x 1 5/8" Steel Studs (16" o.c.) Supporting Interior Finish – Continuous Concrete Intermediate Floor Intersection

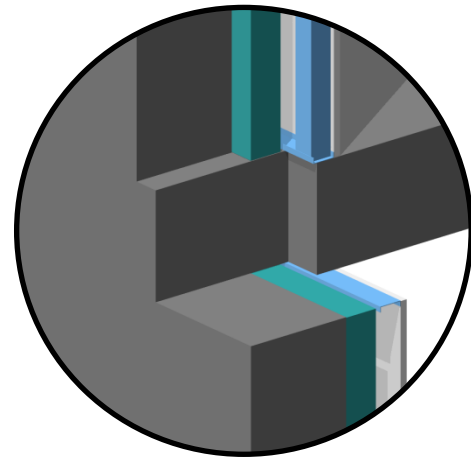
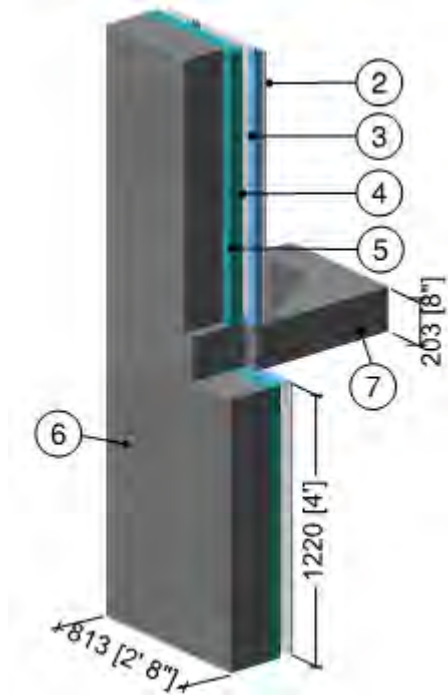

Continuous Concrete Slab Detail

ID	Component	Thickness Inches (mm)	Conductivity Btu·in / ft ² ·hr·°F (W/m K)	Nominal Resistance hr·ft ² ·°F/Btu (m ² K/W)	Density lb/ft ³ (kg/m ³)	Specific Heat Btu/lb·°F (J/kg K)
1	Interior Film ¹	-	-	R-0.6 to R-0.9 (0.11 RSI to 0.16 RSI)	-	-
2	Gypsum Board	1/2" (13)	1.1 (0.16)	R-0.5 (0.08 RSI)	50 (800)	0.26 (1090)
3	1 5/8" x 1 5/8" Steel Studs with Top and Bottom Tracks	18 Gauge	430 (62)	-	489 (7830)	0.12 (500)
4	Air in Stud Cavity	1 5/8" (41)	-	R-0.9 (0.16 RSI)	0.075 (1.2)	0.24 (1000)
5	Continuous Insulation	2 1/2" (64)	0.2 (0.029)	R-12.5 (2.20 RSI)	1.8 (28)	0.29 (1220)
6	Concrete Wall	8" (203)	12.5 (1.8)	-	140 (2250)	0.20 (850)
7	Concrete Slab	8" (203)	12.5 (1.8)	-	140 (2250)	0.20 (850)
8	Exterior Film ¹	-	-	R-0.2 (0.03 RSI)	-	-

¹ Value selected from table 1, p. 26.1 of 2009 ASHRAE Handbook – Fundamentals depending on surface orientation

Detail 7.2.6

Precast Wall Assembly with 3 5/8" x 1 5/8" Steel Stud (16" o.c.) and Insulation in Stud Cavity – Intermediate Floor Intersection

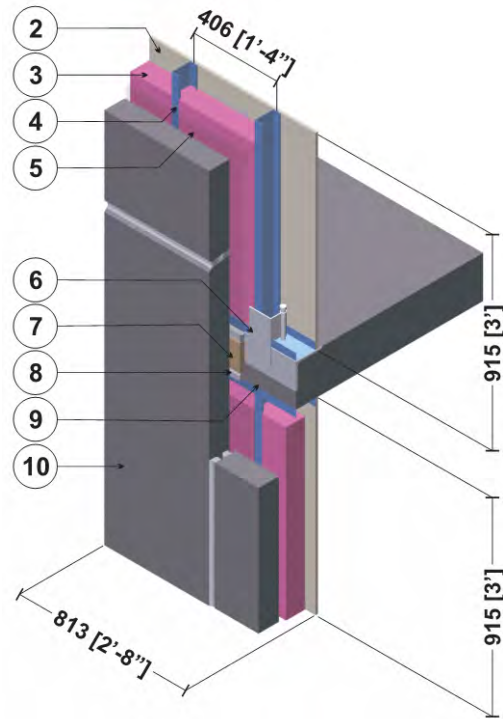

ID	Component	Thickness Inches (mm)	Conductivity Btu-in / ft ² ·hr·°F (W/m K)	Nominal Resistance hr·ft ² ·°F/Btu (m ² K/W)	Density lb/ft ³ (kg/m ³)	Specific Heat Btu/lb·°F (J/kg K)
1	Interior Film ¹	-	-	R-0.6 to R-0.9 (0.11 RSI to 0.16 RSI)	-	-
2	Gypsum Board	1/2" (13)	1.1 (0.16)	R-0.5 (0.08 RSI)	50 (800)	0.26 (1090)
3	Fiberglass Batt Insulation	3 5/8" (92)	0.29 (0.042)	R-12 (2.1 RSI)	0.9 (14)	0.17 (710)
4	3 5/8" x 1 5/8" Steel Studs with Top and Bottom Tracks	18 Gauge	430 (62)	-	489 (7830)	0.12 (500)
5	Air in Stud Cavity	2" (51)	-	R-0.9 (0.16 RSI)	0.075 (1.2)	0.24 (1000)
6	Gravity and Slot Anchors at Slab	-	347 (50)	-	489 (7830)	0.12 (500)
7	Semi Rigid Insulation	1" (25)	0.28 (0.04)	R-3.6 (0.64 RSI)	4.5 (72)	0.17 (710)
8	Silicone Sealant	-	2.4 (0.35)	-	-	-
9	Concrete Slab	8" (203)	12.5 (1.8)	-	140 (2250)	0.20 (850)
10	Precast Wall Panel	4" (102)	12.5 (1.8)	-	140 (2250)	0.20 (850)
11	Exterior Film ¹	-	-	R-0.2 (0.03 RSI)	-	-

¹ Value selected from table 1, p. 26.1 of 2009 ASHRAE Handbook – Fundamentals depending on surface orientation

Detail 7.2.7

Precast Wall Assembly with 3 5/8" x 1 5/8" Steel Stud (16" o.c.) and Rigid Insulation Outboard of Studs – Intermediate Floor Intersection

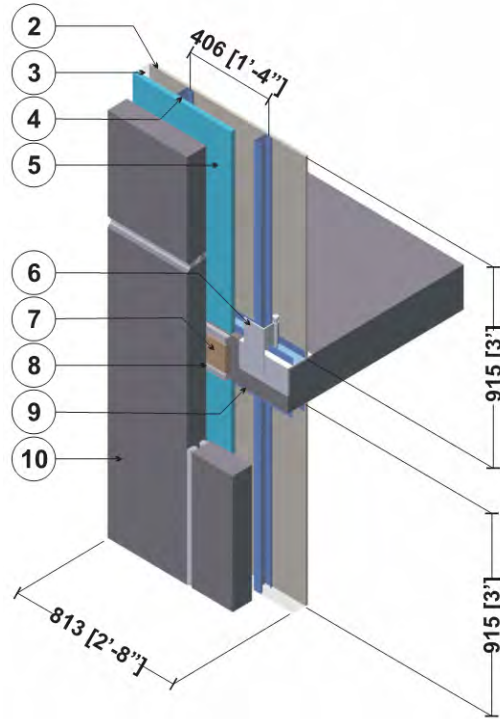

ID	Component	Thickness Inches (mm)	Conductivity Btu-in / ft ² ·hr·°F (W/m K)	Nominal Resistance hr·ft ² ·°F/Btu (m ² K/W)	Density lb/ft ³ (kg/m ³)	Specific Heat Btu/lb·°F (J/kg K)
1	Interior Film ¹	-	-	R-0.6 to R-0.9 (0.11 RSI to 0.16 RSI)	-	-
2	Gypsum Board	1/2" (13)	1.1 (0.16)	R-0.5 (0.08 RSI)	50 (800)	0.26 (1090)
3	Air in Stud Cavity	3 5/8" (92)	-	R-0.9 (0.16 RSI)	0.075 (1.2)	0.24 (1000)
4	3 5/8" x 1 5/8" Steel Studs with Top and Bottom Tracks	18 Gauge	430 (62)	-	489 (7830)	0.12 (500)
5	Rigid Insulation	2" (51)	-	R-10 (1.8 RSI)	1.8 (28)	0.29 (1220)
6	Gravity and Slot Anchors at Slab	-	347 (50)	-	489 (7830)	0.12 (500)
7	Semi Rigid Insulation	1" (25)	0.28 (0.04)	R-3.6 (0.64 RSI)	4.5 (72)	0.17 (710)
8	Silicone Sealant	-	2.4 (0.35)	-	-	-
9	Concrete Slab	8" (203)	12.5 (1.8)	-	140 (2250)	0.20 (850)
10	Precast Wall Panel	4" (102)	12.5 (1.8)	-	140 (2250)	0.20 (850)
11	Exterior Film ¹	-	-	R-0.2 (0.03 RSI)	-	-

¹ Value selected from table 1, p. 26.1 of 2009 ASHRAE Handbook – Fundamentals depending on surface orientation

Detail 7.2.8

Precast Sandwich Panel Wall Assembly with 3 5/8" x 1 5/8" Steel Stud (16" o.c.) – Intermediate Floor Intersection

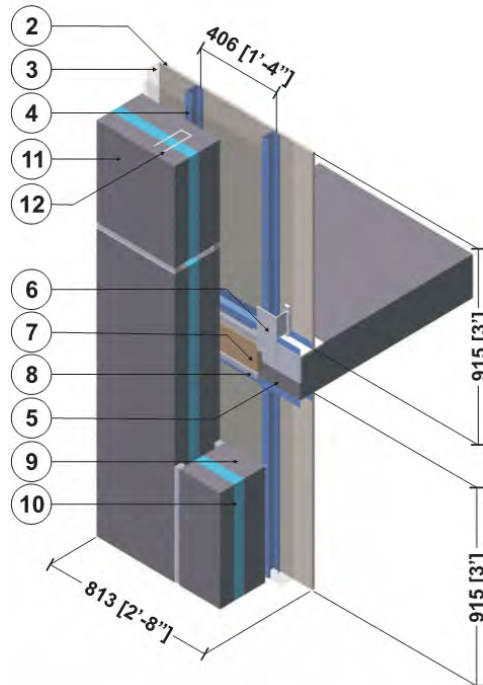

ID	Component	Thickness Inches (mm)	Conductivity Btu-in / ft ² ·hr·°F (W/m K)	Nominal Resistance hr·ft ² ·°F/Btu (m ² K/W)	Density lb/ft ³ (kg/m ³)	Specific Heat Btu/lb·°F (J/kg K)
1	Interior Film ¹	-	-	R-0.6 to R-0.9 (0.11 RSI to 0.16 RSI)	-	-
2	Gypsum Board	1/2" (13)	1.1 (0.16)	R-0.5 (0.08 RSI)	50 (800)	0.26 (1090)
3	Air in Stud Cavity	5 5/8" (143)	-	R-0.9 (0.16 RSI)	0.075 (1.2)	0.24 (1000)
4	3 5/8" x 1 5/8" Steel Studs with Top and Bottom Tracks	18 Gauge	430 (62)	-	489 (7830)	0.12 (500)
5	Concrete Slab	8" (203)	12.5 (1.8)	-	140 (2250)	0.20 (850)
6	Gravity and Slot Anchors at Slab	-	347 (50)	-	489 (7830)	0.12 (500)
7	Semi Rigid Insulation	1" (25)	0.28 (0.04)	R-3.6 (0.64 RSI)	4.5 (72)	0.17 (710)
8	Silicone Sealant	-	2.4 (0.35)	-	-	-
9	Precast Sandwich Panel, Interior Concrete	4" (102)	12.5 (1.8)	-	140 (2250)	0.20 (850)
10	Precast Sandwich Panel, Insulation	2" (51)	-	R-10 (1.8 RSI)	1.8 (28)	0.29 (1220)
11	Precast Sandwich Panel, Exterior Concrete	4" (102)	12.5 (1.8)	-	140 (2250)	0.20 (850)
12	Precast Sandwich Panel, Structural Ties @ 24" (610) o.c.	16 Gauge	430 (62)	-	489 (7830)	0.12 (500)
13	Exterior Film ¹	-	-	R-0.2 (0.03 RSI)	-	-

¹ Value selected from table 1, p. 26.1 of 2009 ASHRAE Handbook – Fundamentals depending on surface orientation

Detail 7.2.9

Precast Sandwich Panel Wall Assembly with Concrete at Panel Perimeter and Steel Connectors at 24" o.c. – Intermediate Floor Intersection

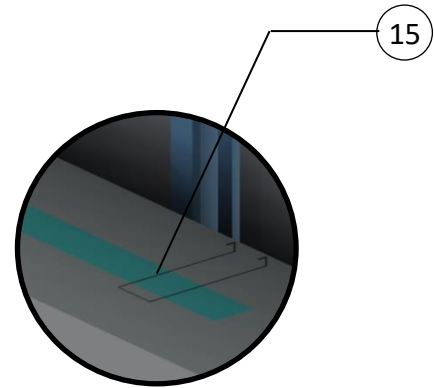
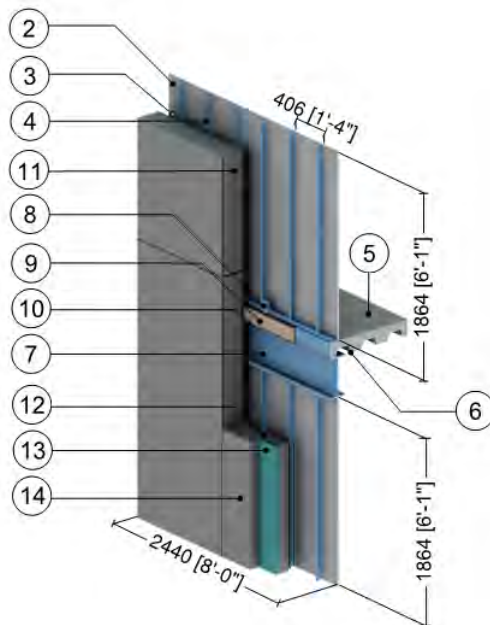

Connector Detail

ID	Component	Thickness Inches (mm)	Conductivity Btu-in / ft ² -hr-°F (W/m K)	Nominal Resistance hr-ft ² -°F/Btu (m ² K/W)	Density lb/ft ³ (kg/m ³)	Specific Heat Btu/lb-°F (J/kg K)
1	Interior Film (bottom) ¹	-	-	R-0.6 to R-0.9 (0.11 RSI to 0.16 RSI)	-	-
2	Gypsum Board	1/2" (13)	1.1 (0.16)	R-0.5 (0.08 RSI)	50 (800)	0.26 (1090)
3	Air in Stud Cavity	5 5/8" (143)	-	R-0.9 (0.16 RSI)	0.075 (1.2)	0.24 (1000)
4	3 5/8" x 1 5/8" Steel Studs with Top and Bottom Tracks	18 Gauge	430 (62)	-	489 (7830)	0.12 (500)
5	Concrete Topping	6" (152)	6.3 (0.9)	-	120 (1920)	0.20 (850)
6	Steel Deck	1/16" (1.6)	347 (50)	-	489 (7830)	0.12 (500)
7	Steel Beam (W410)	-	347 (50)	-	489 (7830)	0.12 (500)
8	Gravity and Slot Anchors at Slab	-	347 (50)	-	489 (7830)	0.12 (500)
9	Semi Rigid Insulation	1" (25)	0.24 (0.034)	R-4.2 (0.75 RSI)	4 (64)	0.20 (850)
10	Silicone Sealant	-	2.4 (0.35)	-	174 (2800)	0.17 (700)
11	Concrete at Panel Edges	12" (305)	12.5 (1.8)	-	140 (2250)	.20 (850)
12	Precast Sandwich Panel, Interior Concrete	4" (102)	12.5 (1.8)	-	140 (2250)	0.20 (850)
13	Precast Sandwich Panel, Insulation	2" (51)	-	R-10 (1.76 RSI)	1.8 (28)	0.29 (1220)
14	Precast Sandwich Panel, Exterior Concrete	4" (102)	12.5 (1.8)	-	140 (2250)	0.20 (850)
15	Precast Sandwich Panel, Steel Connectors @ 24" (610) o.c.	16 Gauge	430 (62)	-	489 (7830)	0.12 (500)
16	Exterior Film ¹	-	-	R-0.2 (0.03 RSI)	-	-

¹ Value selected from table 1, p. 26.1 of 2009 ASHRAE Handbook – Fundamentals depending on surface orientation

Detail 7.2.10

Precast Sandwich Panel Wall Assembly with Steel Connectors at 16" o.c. – Intermediate Floor Intersection

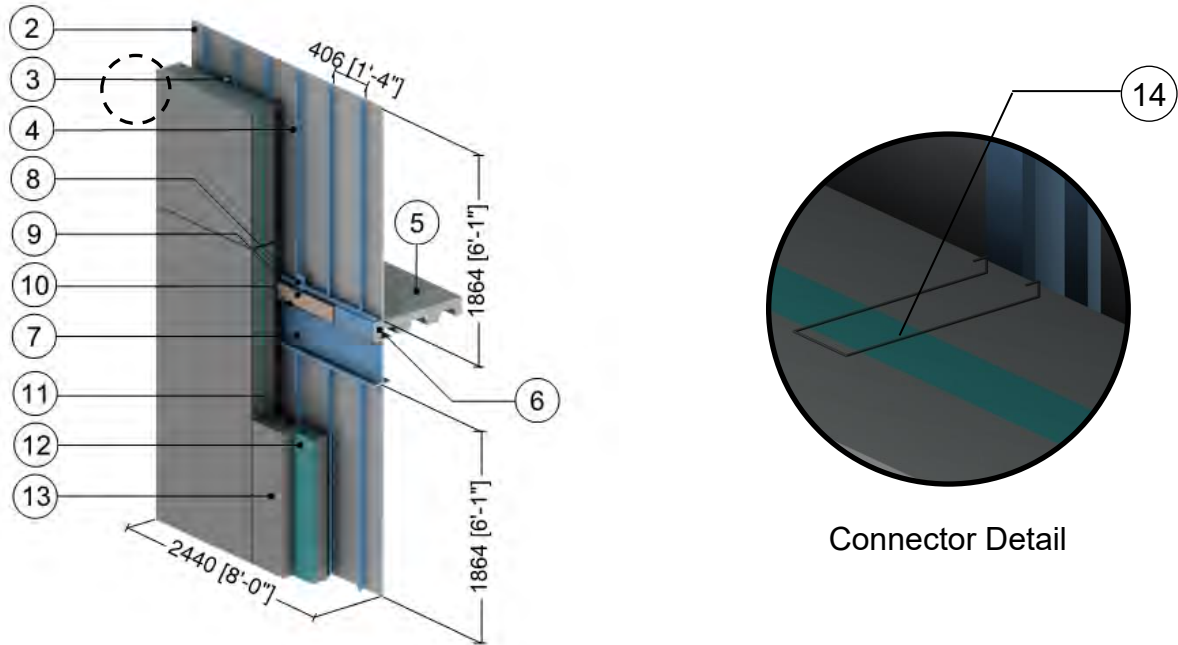

ID	Component	Thickness Inches (mm)	Conductivity Btu-in / ft ² -hr-°F (W/m K)	Nominal Resistance hr-ft ² -°F/Btu (m ² K/W)	Density lb/ft ³ (kg/m ³)	Specific Heat Btu/lb-°F (J/kg K)
1	Interior Film (bottom) ¹	-	-	R-0.6 to R-0.9 (0.11 RSI to 0.16 RSI)	-	-
2	Gypsum Board	1/2" (13)	1.1 (0.16)	R-0.5 (0.08 RSI)	50 (800)	0.26 (1090)
3	Air in Stud Cavity	5 5/8" (143)	-	R-0.9 (0.16 RSI)	0.075 (1.2)	0.24 (1000)
4	3 5/8" x 1 5/8" Steel Studs with Top and Bottom Tracks	18 Gauge	430 (62)	-	489 (7830)	0.12 (500)
5	Concrete Topping	6" (152)	6.3 (0.9)	-	120 (1920)	0.20 (850)
6	Steel Deck	1/16" (1.6)	347 (50)	-	489 (7830)	0.12 (500)
7	Steel Beam (W410)	-	347 (50)	-	489 (7830)	0.12 (500)
8	Gravity and Slot Anchors at Slab	-	347 (50)	-	489 (7830)	0.12 (500)
9	Semi Rigid Insulation	1" (25)	0.24 (0.034)	R-4.2 (0.75 RSI)	4 (64)	0.20 (850)
10	Silicone Sealant	-	2.4 (0.35)	-	174 (2800)	0.17 (700)
11	Precast Sandwich Panel, Interior Concrete	4" (102)	12.5 (1.8)	-	140 (2250)	0.20 (850)
12	Precast Sandwich Panel, Insulation	2" (51)	-	R-10 (1.76 RSI)	1.8 (28)	0.29 (1220)
13	Precast Sandwich Panel, Exterior Concrete	4" (102)	12.5 (1.8)	-	140 (2250)	0.20 (850)
14	Precast Sandwich Panel, Steel Connectors @ 16" (406) o.c.	16 Gauge	430 (62)	-	489 (7830)	0.12 (500)
15	Exterior Film ¹	-	-	R-0.2 (0.03 RSI)	-	-

¹ Value selected from table 1, p. 26.1 of 2009 ASHRAE Handbook – Fundamentals depending on surface orientation



Detail 7.2.11

Precast Sandwich Panel Wall Assembly with Steel Connectors at 36" o.c. – Intermediate Floor Intersection

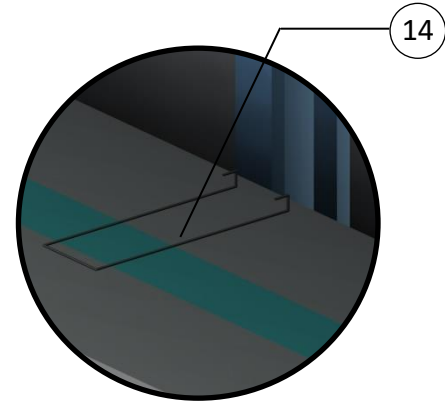
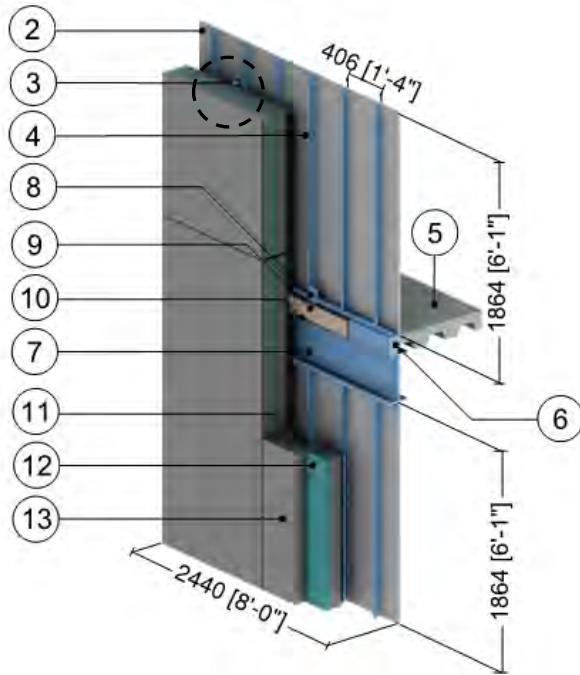

Connector Detail

ID	Component	Thickness Inches (mm)	Conductivity Btu-in / ft ² -hr-°F (W/m K)	Nominal Resistance hr-ft ² -°F/Btu (m ² K/W)	Density lb/ft ³ (kg/m ³)	Specific Heat Btu/lb-°F (J/kg K)
1	Interior Film (bottom) ¹	-	-	R-0.6 to R-0.9 (0.11 RSI to 0.16 RSI)	-	-
2	Gypsum Board	1/2" (13)	1.1 (0.16)	R-0.5 (0.08 RSI)	50 (800)	0.26 (1090)
3	Air in Stud Cavity	5 5/8" (143)	-	R-0.9 (0.16 RSI)	0.075 (1.2)	0.24 (1000)
4	3 5/8" x 1 5/8" Steel Studs with Top and Bottom Tracks	18 Gauge	430 (62)	-	489 (7830)	0.12 (500)
5	Concrete Topping	6" (152)	6.3 (0.9)	-	120 (1920)	0.20 (850)
6	Steel Deck	1/16" (1.6)	347 (50)	-	489 (7830)	0.12 (500)
7	Steel Beam (W410)	-	347 (50)	-	489 (7830)	0.12 (500)
8	Gravity and Slot Anchors at Slab	-	347 (50)	-	489 (7830)	0.12 (500)
9	Semi Rigid Insulation	1" (25)	0.24 (0.034)	R-4.2 (0.75 RSI)	4 (64)	0.20 (850)
10	Silicone Sealant	-	2.4 (0.35)	-	-	-
11	Precast Sandwich Panel, Interior Concrete	4" (102)	12.5 (1.8)	-	140 (2250)	0.20 (850)
12	Precast Sandwich Panel, Insulation	2" (51)	-	R-10 (1.76 RSI)	1.8 (28)	0.29 (1220)
13	Precast Sandwich Panel, Exterior Concrete	4" (102)	12.5 (1.8)	-	140 (2250)	0.20 (850)
14	Precast Sandwich Panel, Steel Connectors @ 36" (914) o.c.	16 Gauge	430 (62)	-	489 (7830)	0.12 (500)
15	Exterior Film ¹	-	-	R-0.2 (0.03 RSI)	-	-

¹ Value selected from table 1, p. 26.1 of 2009 ASHRAE Handbook – Fundamentals depending on surface orientation

Detail 7.2.12

Precast Sandwich Panel Wall Assembly with Steel Connectors at 48" o.c. – Intermediate Floor Intersection

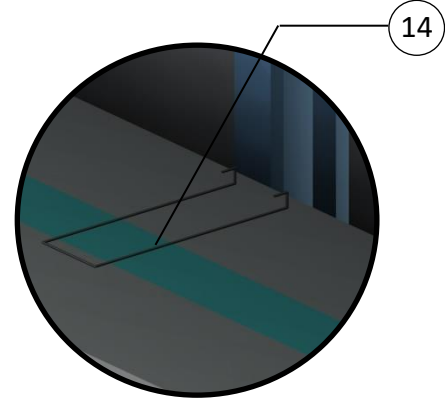
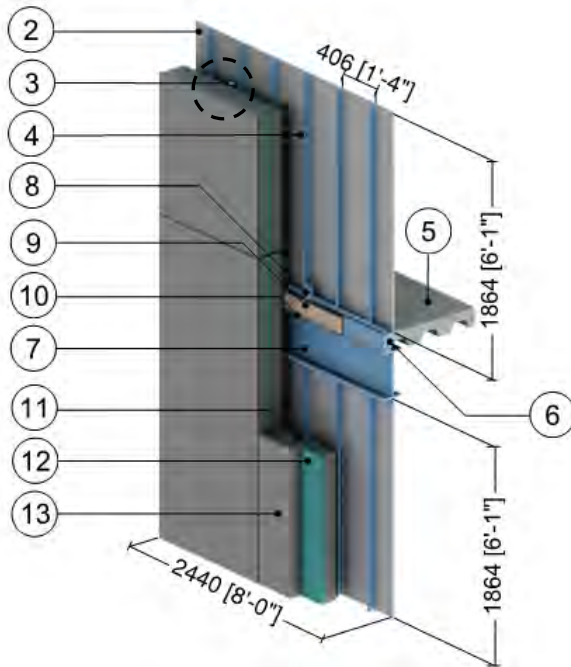

Connector Detail

ID	Component	Thickness Inches (mm)	Conductivity Btu·in / ft ² ·hr·°F (W/m K)	Nominal Resistance hr·ft ² ·°F/Btu (m ² K/W)	Density lb/ft ³ (kg/m ³)	Specific Heat Btu/lb·°F (J/kg K)
1	Interior Film (bottom) ¹	-	-	R-0.6 to R-0.9 (0.11 RSI to 0.16 RSI)	-	-
2	Gypsum Board	1/2" (13)	1.1 (0.16)	R-0.5 (0.08 RSI)	50 (800)	0.26 (1090)
3	Air in Stud Cavity	3 5/8" (143)	-	R-0.9 (0.16 RSI)	0.075 (1.2)	0.24 (1000)
4	3 5/8" x 1 5/8" Steel Studs with Top and Bottom Tracks	18 Gauge	430 (62)	-	489 (7830)	0.12 (500)
5	Concrete Topping	6" (152)	6.3 (0.9)	-	120 (1920)	0.20 (850)
6	Steel Deck	1/16" (1.6)	347 (50)	-	489 (7830)	0.12 (500)
7	Steel Beam (W410)	-	347 (50)	-	489 (7830)	0.12 (500)
8	Gravity and Slot Anchors at Slab	-	347 (50)	-	489 (7830)	0.12 (500)
9	Semi Rigid Insulation	1" (25)	0.24 (0.034)	R-4.2 (0.75 RSI)	4 (64)	0.20 (850)
10	Silicone Sealant	-	2.4 (0.35)	-	-	-
11	Precast Sandwich Panel, Interior Concrete	4" (102)	12.5 (1.8)	-	140 (2250)	0.20 (850)
12	Precast Sandwich Panel, Insulation	2" (51)	-	R-10 (1.76 RSI)	1.8 (28)	0.29 (1220)
13	Precast Sandwich Panel, Exterior Concrete	4" (102)	12.5 (1.8)	-	140 (2250)	0.20 (850)
14	Precast Sandwich Panel, Steel Connectors @ 48" (1220) o.c.	16 Gauge	430 (62)	-	489 (7830)	0.12 (500)
15	Exterior Film ¹	-	-	R-0.2 (0.03 RSI)	-	-

¹ Value selected from table 1, p. 26.1 of 2009 ASHRAE Handbook – Fundamentals depending on surface orientation

Detail 7.2.13

Precast Sandwich Panel Wall Assembly with Fiber-Reinforced Composite Connections at 16" o.c. – Intermediate Floor Intersection

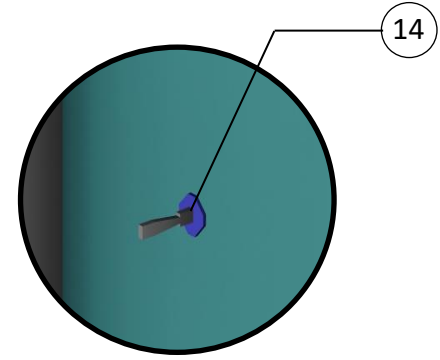
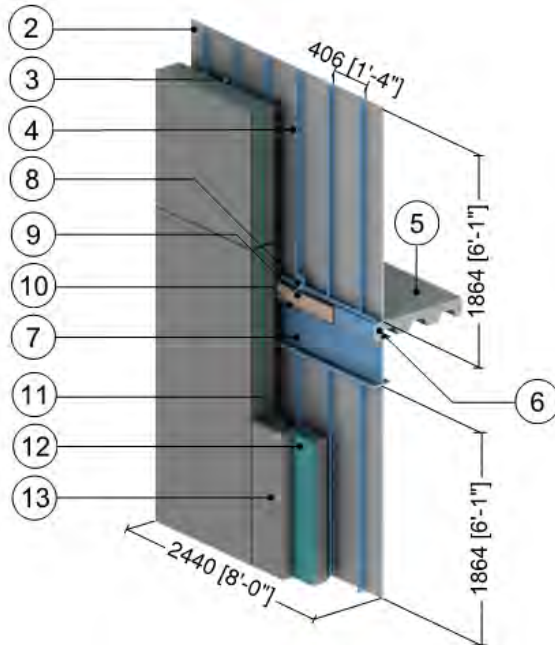

Connector Detail

ID	Component	Thickness Inches (mm)	Conductivity Btu-in / ft ² -hr-°F (W/m K)	Nominal Resistance hr-ft ² -°F/Btu (m ² K/W)	Density lb/ft ³ (kg/m ³)	Specific Heat Btu/lb-°F (J/kg K)
1	Interior Film (bottom) ¹	-	-	R-0.6 to R-0.9 (0.11 RSI to 0.16 RSI)	-	-
2	Gypsum Board	1/2" (13)	1.1 (0.16)	R-0.5 (0.08 RSI)	50 (800)	0.26 (1090)
3	Air in Stud Cavity	5 5/8" (143)	-	R-0.9 (0.16 RSI)	0.075 (1.2)	0.24 (1000)
4	3 5/8" x 1 5/8" Steel Studs with Top and Bottom Tracks	18 Gauge	430 (62)	-	489 (7830)	0.12 (500)
5	Concrete Topping	6" (152)	6.3 (0.9)	-	120 (1920)	0.20 (850)
6	Steel Deck	1/16" (1.6)	347 (50)	-	489 (7830)	0.12 (500)
7	Steel Beam (W410)	-	347 (50)	-	489 (7830)	0.12 (500)
8	Gravity and Slot Anchors at Slab	-	347 (50)	-	489 (7830)	0.12 (500)
9	Semi Rigid Insulation	1" (25)	0.24 (0.034)	R-4.2 (0.75 RSI)	4 (64)	0.20 (850)
10	Silicone Sealant	-	2.4 (0.35)	-	-	-
11	Precast Sandwich Panel, Interior Concrete	4" (102)	12.5 (1.8)	-	140 (2250)	0.20 (850)
12	Precast Sandwich Panel, Insulation	2" (51)	-	R-10 (1.76 RSI)	1.8 (28)	0.29 (1220)
13	Precast Sandwich Panel, Exterior Concrete	4" (102)	12.5 (1.8)	-	140 (2250)	0.20 (850)
14	Precast Sandwich Panel, Fiber-Reinforced Composite Connectors @ 16" (406) o.c.	-	6.9 (1.0)	-	-	-
15	Exterior Film ¹	-	-	R-0.2 (0.03 RSI)	-	-

¹ Value selected from table 1, p. 26.1 of 2009 ASHRAE Handbook – Fundamentals depending on surface orientation



Detail 7.2.14

Exterior Insulated Concrete Block Wall Assembly with Shelf Angle & Brick Ties Supporting Brick Veneer – Intermediate Floor Intersection

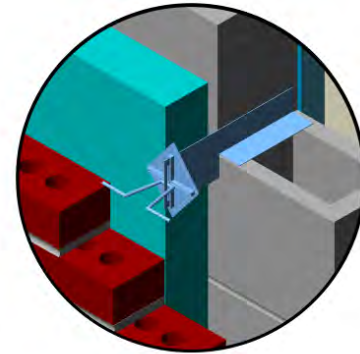
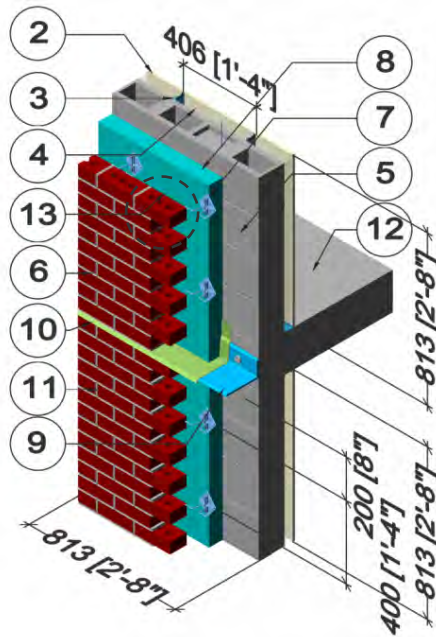

Brick Tie Detail

ID	Component	Thickness Inches (mm)	Conductivity Btu-in / ft ² ·hr·°F (W/m K)	Nominal Resistance hr·ft ² ·°F/Btu (m ² K/W)	Density lb/ft ³ (kg/m ³)	Specific Heat Btu/lb·°F (J/kg K)
1	Interior Film ¹	-	-	R-0.6 to R-0.9 (0.11 RSI to 0.16 RSI)	-	-
2	Gypsum Board	1/2" (13)	1.1 (0.16)	R-0.5 (0.08 RSI)	50 (800)	0.26 (1090)
3	1 5/8" Steel Studs with Metal Tracks	20 Gauge	430 (62)	-	489 (7830)	0.12 (500)
4	Air in Stud Cavity	1 5/8" (41)	-	R-0.9 (0.16 RSI)	0.075 (1.2)	0.24 (1000)
5	Standard Concrete Block	7 5/8" (190)	3.5 (0.5)	-	119 (1900)	0.19 (800)
6	Cement Mortar	-	3.5 (0.5)	-	113 (1800)	0.12 (500)
7	Masonry Ties @ 16" (406) o.c.	14 Gauge	347 (50)	-	489 (7830)	0.12 (500)
8	Exterior Insulation	Varies	-	R-5 to R-25 (0.88 RSI to 4.4 RSI)	1.8 (28)	0.29 (1220)
9	Shelf Angle	3/8" (10)	347 (50)	-	489 (7830)	0.12 (500)
10	Flashing	20 Gauge	347 (50)	-	489 (7830)	0.12 (500)
11	Brick Veneer	3 5/8" (92)	5.4 (0.78)	-	120 (1920)	0.19 (720)
12	Concrete Slab	8" (203)	12.5 (1.8)	-	140 (2250)	0.20 (850)
13	Air Gap	1" (25)	-	R-0.9 (0.16 RSI)	0.075 (1.2)	0.24 (1000)
14	Exterior Film ¹	-	-	R-0.2 (0.03 RSI)	-	-

¹ Value selected from table 1, p. 26.1 of 2009 ASHRAE Handbook – Fundamentals depending on surface orientation



Detail 7.2.15

Exterior Insulated Concrete Block Wall Assembly with Stand-Off Shelf Angle & Brick Ties Supporting Brick Veneer – Intermediate Floor Intersection

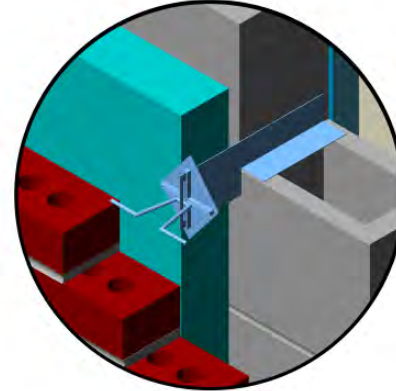
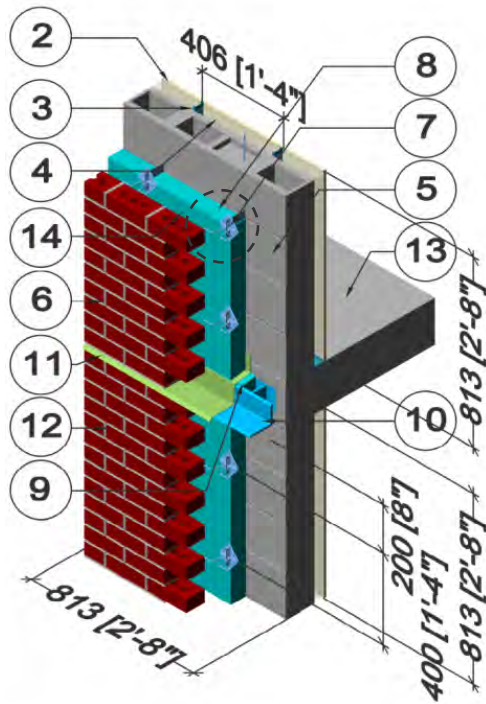

Brick Tie Detail

ID	Component	Thickness Inches (mm)	Conductivity Btu-in / ft ² ·hr·°F (W/m K)	Nominal Resistance hr·ft ² ·°F/Btu (m ² K/W)	Density lb/ft ³ (kg/m ³)	Specific Heat Btu/lb·°F (J/kg K)
1	Interior Film ¹	-	-	R-0.6 to R-0.9 (0.11 RSI to 0.16 RSI)	-	-
2	Gypsum Board	1/2" (13)	1.1 (0.16)	R-0.5 (0.08 RSI)	50 (800)	0.26 (1090)
3	1 5/8" Steel Studs with Metal Tracks	20 Gauge	430 (62)	-	489 (7830)	0.12 (500)
4	Air in Stud Cavity	1 5/8" (41)	-	R-0.9 (0.16 RSI)	0.075 (1.2)	0.24 (1000)
5	Standard Concrete Block	7 5/8" (190)	3.5 (0.5)	-	119 (1900)	0.19 (800)
6	Cement Mortar	-	3.5 (0.5)	-	113 (1800)	0.12 (500)
7	Masonry Ties @ 16" (406) o.c.	14 Gauge	347 (50)	-	489 (7830)	0.12 (500)
8	Exterior Insulation	Varies	-	R-5 to R-25 (0.88 RS) to 4.4 RSI)	1.8 (28)	0.29 (1220)
9	Insulation Behind Shelf Angle	Varies	-	R-5 to R-25 (0.88 RSI to 4.4 RSI)	1.8 (28)	0.29 (1220)
10	Stand-Off Shelf Angle	3/8" (10)	347 (50)	-	489 (7830)	0.12 (500)
11	Flashing	20 Gauge	347 (50)	-	489 (7830)	0.12 (500)
12	Brick Veneer	3 5/8" (92)	5.4 (0.78)	-	120 (1920)	0.19 (720)
13	Concrete Slab	8" (203)	12.5 (1.8)	-	140 (2250)	0.20 (850)
14	Air Gap	1" (25)	-	R-0.9 (0.16 RSI)	0.075 (1.2)	0.24 (1000)
15	Exterior Film ¹	-	-	R-0.2 (0.03 RSI)	-	-

¹ Value selected from table 1, p. 26.1 of 2009 ASHRAE Handbook – Fundamentals depending on surface orientation



Detail 7.2.16

Exterior Insulated Concrete Block Wall Assembly with Masonry Ties Supporting Brick Veneer – Intermediate Floor Intersection at Balcony

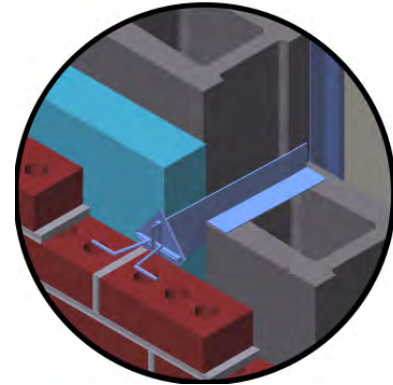
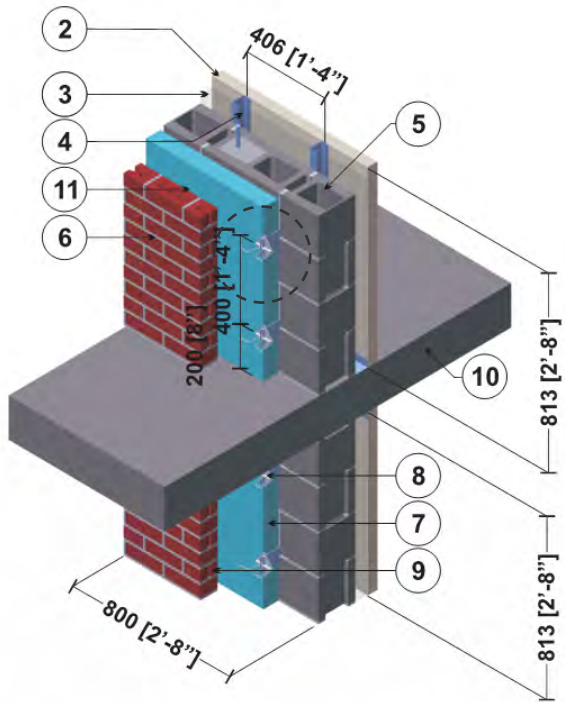

Brick Tie Detail

ID	Component	Thickness Inches (mm)	Conductivity Btu-in / ft ² -hr-°F (W/m K)	Nominal Resistance hr-ft ² -°F/Btu (m ² K/W)	Density lb/ft ³ (kg/m ³)	Specific Heat Btu/lb-°F (J/kg K)
1	Interior Film ¹	-	-	R-0.6 to R-0.9 (0.11 RSI to 0.16 RSI)	-	-
2	Gypsum Board	1/2" (13)	1.1 (0.16)	R-0.5 (0.08 RSI)	50 (800)	0.26 (1090)
3	Air in Stud Cavity	1 5/8" (41)	-	R-0.9 (0.16 RSI)	0.075 (1.2)	0.24 (1000)
4	1 5/8" Steel Studs with Metal Tracks	20 Gauge	430 (62)	-	489 (7830)	0.12 (500)
5	Standard Concrete Block	7 5/8" (190)	3.5 (0.5)	-	119 (1900)	0.19 (800)
6	Cement Mortar	-	3.5 (0.5)	-	113 (1800)	0.12 (500)
7	Exterior Insulation	Varies	-	R-5 to R-25 (0.88 RSI to 4.4 RSI)	1.8 (28)	0.29 (1220)
8	Masonry Ties @ 16" (406) o.c.	14 Gauge	347 (50)	-	489 (7830)	0.12 (500)
9	Brick Veneer	3 5/8" (90)	5.4 (0.78)	-	120 (1920)	0.19 (720)
10	Concrete Slab	8" (203)	12.5 (1.8)	-	140 (2250)	0.20 (850)
11	Air Gap	1" (25)	-	R-0.9 (0.16 RSI)	0.075 (1.2)	0.24 (1000)
12	Exterior Film ¹	-	-	R-0.2 (0.03 RSI)	-	-

¹ Value selected from table 1, p. 26.1 of 2009 ASHRAE Handbook – Fundamentals depending on surface orientation



Detail 7.2.17

Exterior Insulated Concrete Block Wall Assembly with Masonry Ties Supporting Brick Veneer – Angle Supported Slab & Intermediate Floor Intersection

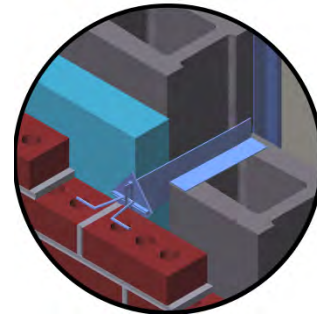
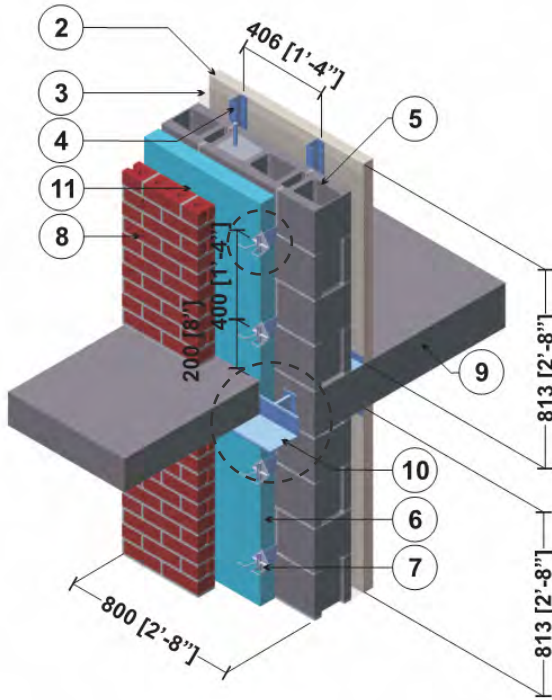

Brick Tie Detail

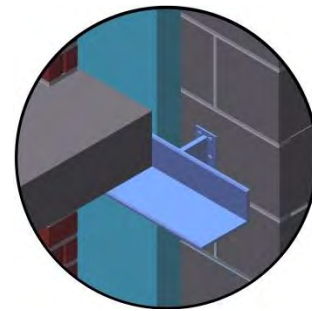

Shelf Angle Detail

ID	Component	Thickness Inches (mm)	Conductivity Btu-in / ft ² ·hr·°F (W/m K)	Nominal Resistance hr·ft ² ·°F/Btu (m ² K/W)	Density lb/ft ³ (kg/m ³)	Specific Heat Btu/lb·°F (J/kg K)
1	Interior Film ¹	-	-	R-0.6 to R-0.9 (0.11 RSI to 0.16 RSI)	-	-
2	Gypsum Board	1/2" (13)	1.1 (0.16)	R-0.5 (0.08 RSI)	50 (800)	0.26 (1090)
3	Air in Stud Cavity	1 5/8" (41)	-	R-0.9 (0.16 RSI)	0.075 (1.2)	0.24 (1000)
4	1 5/8" Steel Studs with Metal Tracks	20 Gauge	430 (62)	-	489 (7830)	0.12 (500)
5	Standard Concrete Block	7 5/8" (190)	3.5 (0.5)	-	119 (1900)	0.19 (800)
6	Exterior Insulation	Varies	-	R-5 to R-25 (0.88 RSI to 4.4 RSI)	1.8 (28)	0.29 (1220)
7	Masonry Ties @ 16" (406) o.c.	14 Gauge	347 (50)	-	489 (7830)	0.12 (500)
8	Brick Veneer	3 5/8" (92)	5.4 (0.78)	-	120 (1920)	0.19 (720)
9	Concrete Slab	8" (203)	12.5 (1.8)	-	140 (2250)	0.20 (850)
10	Slab & Brick (Anchored to Slab at 16" o.c.) Support Angle	-	347 (50)	-	489 (7830)	0.12 (500)
11	Air Gap	1" (25)	-	R-0.9 (0.16 RSI)	0.075 (1.2)	0.24 (1000)
12	Exterior Film ¹	-	-	R-0.2 (0.03 RSI)	-	-

¹ Value selected from table 1, p. 26.1 of 2009 ASHRAE Handbook – Fundamentals depending on surface orientation

Detail 7.2.18

Exterior Insulated Concrete Block Wall Assembly with Masonry Ties Supporting Brick Veneer – Intermediate Floor Intersection at Balcony

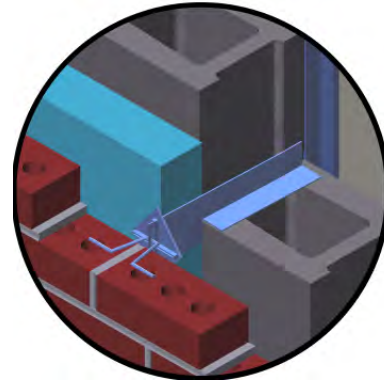
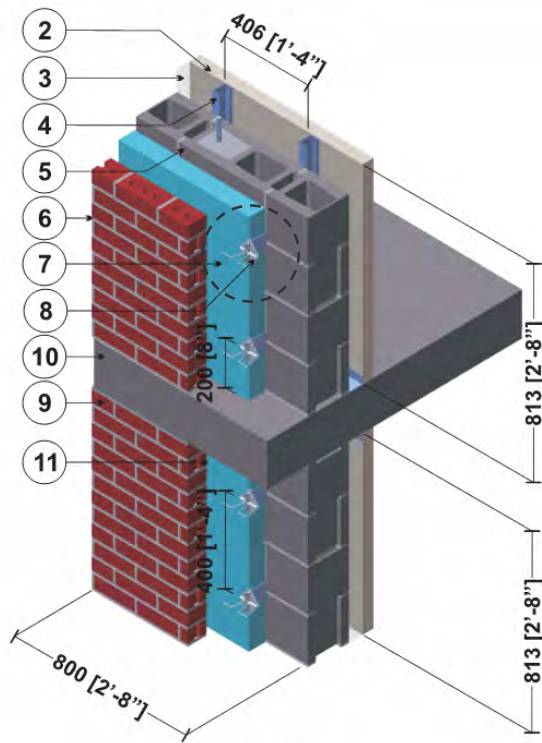

Brick Tie Detail

ID	Component	Thickness Inches (mm)	Conductivity Btu-in / ft ² ·hr·°F (W/m K)	Nominal Resistance hr·ft ² ·°F/Btu (m ² K/W)	Density lb/ft ³ (kg/m ³)	Specific Heat Btu/lb·°F (J/kg K)
1	Interior Film ¹	-	-	R-0.6 to R-0.9 (0.11 RSI to 0.16 RSI)	-	-
2	Gypsum Board	1/2" (13)	1.1 (0.16)	R-0.5 (0.08 RSI)	50 (800)	0.26 (1090)
3	Air in Stud Cavity	1 5/8" (41)	-	R-0.9 (0.16 RSI)	0.075 (1.2)	0.24 (1000)
4	1 5/8" Steel Studs with Metal Tracks	20 Gauge	430 (62)	-	489 (7830)	0.12 (500)
5	Standard Concrete Block	7 5/8" (190)	3.5 (0.5)	-	119 (1900)	0.19 (800)
6	Cement Mortar	-	3.5 (0.5)	-	113 (1800)	0.12 (500)
7	Exterior Insulation	Varies	-	R-5 to R-25 (0.88 RSI to 4.4 RSI)	1.8 (28)	0.29 (1220)
8	Masonry Ties @ 16" (406) o.c.	14 Gauge	347 (50)	-	489 (7830)	0.12 (500)
9	Brick Veneer	3 5/8" (90)	5.4 (0.78)	-	120 (1920)	0.19 (720)
10	Concrete Slab	8" (203)	12.5 (1.8)	-	140 (2250)	0.20 (850)
11	Air Gap	1" (25)	-	R-0.9 (0.16 RSI)	0.075 (1.2)	0.24 (1000)
12	Exterior Film ¹	-	-	R-0.2 (0.03 RSI)	-	-

¹ Value selected from table 1, p. 26.1 of 2009 ASHRAE Handbook – Fundamentals depending on surface orientation



Detail 7.2.19

Exterior Insulated Concrete Block Wall Assembly with Thermally Broken Shelf Angle & Brick Ties Supporting Brick Veneer – Slab Intersection

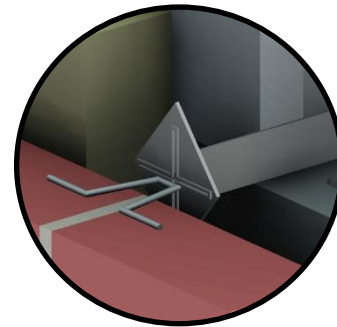
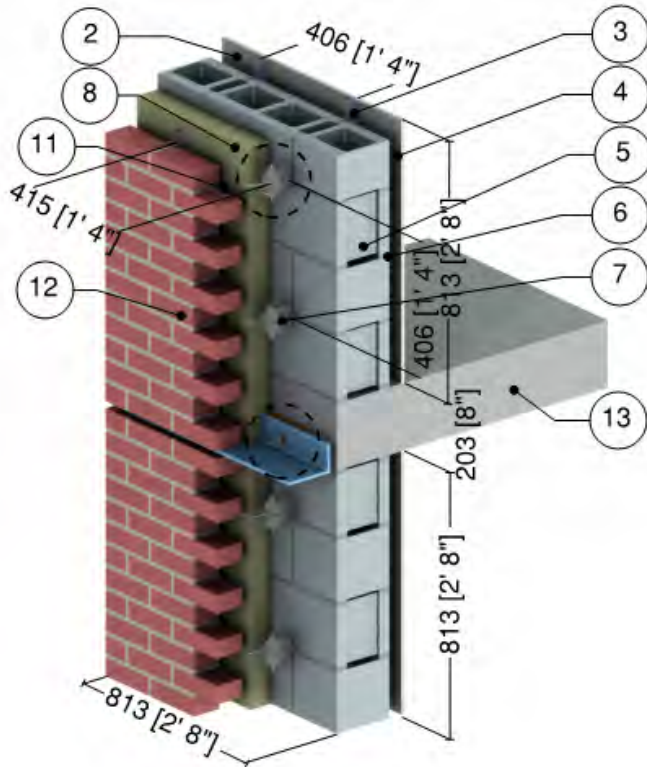

Brick Tie Detail

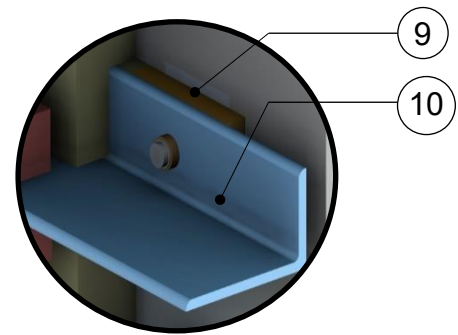

Shelf Angle Detail

ID	Component	Thickness Inches (mm)	Conductivity Btu-in / ft ² -hr-°F (W/m K)	Nominal Resistance hr-ft ² -°F/Btu (m ² K/W)	Density lb/ft ³ (kg/m ³)	Specific Heat Btu/lb-°F (J/kg K)
1	Interior Film ¹	-	-	R-0.6 to R-0.9 (0.11 RSI to 0.16 RSI)	-	-
2	Gypsum Board	1/2" (13)	1.1 (0.16)	R-0.5 (0.08 RSI)	50 (800)	0.26 (1090)
3	1 5/8" Steel Studs with Metal Tracks	20 Gauge	430 (62)	-	489 (7830)	0.12 (500)
4	Air in Stud Cavity	1 5/8" (41)	-	R-0.9 (0.16 RSI)	0.075 (1.2)	0.24 (1000)
5	Standard Concrete Block	7 5/8" (190)	3.5 (0.5)	-	119 (1900)	0.19 (800)
6	Cement Mortar	-	3.5 (0.5)	-	113 (1800)	0.12 (500)
7	Masonry Ties @ 16" (406) o.c.	14 Gauge	347 (50)	-	489 (7830)	0.12 (500)
8	Exterior Insulation	-	-	R-15 (2.64 RSI)	1.8 (28)	0.29 (1220)
9	Armatherm FRR Thermal Break	1" (25)	1.4 (0.20)	-	85 (5.3)	-
10	Steel Shelf Angle and Bolts	3/8" (10)	347 (50)	-	489 (7830)	0.12 (500)
10	Stainless Steel Shelf Angle and Bolts	3/8" (10)	118 (17)	-	503 (8060)	0.12 (500)
11	Air Gap ²	1" (25)	-	R-0.9 (0.16 RSI)	0.075 (1.2)	0.24 (1000)
12	Brick Veneer	3 5/8" (92)	5.4 (0.78)	-	120 (1920)	0.19 (720)
13	Concrete Slab	8" (203)	12.5 (1.8)	-	140 (2250)	0.20 (850)
14	Exterior Film ¹	-	-	R-0.2 (0.03 RSI)	-	-

¹ Value selected from table 1, p. 26.1 of 2009 ASHRAE Handbook – Fundamentals depending on surface orientation

² The thermal conductivity of air spaces was found using ISO 100077-2

Detail 7.2.20

Interior Insulated Concrete Mass Wall with 1 5/8" x 1 5/8" Steel Studs (16" o.c.) Supporting Interior Finish – Isokorb Rutherma DF Thermally Broken Concrete Intermediate Floor Intersection

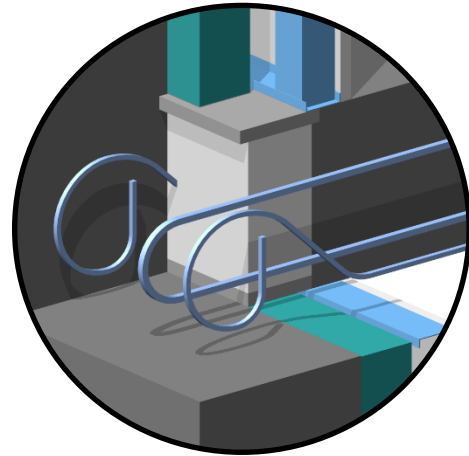
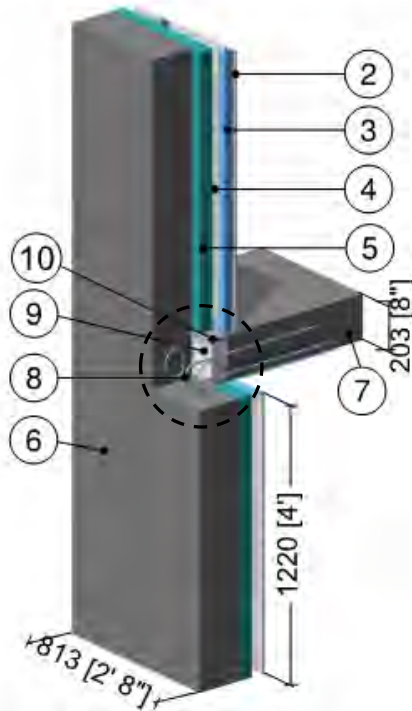

Thermally Broken Slab Detail (Rutherma Type DF)

ID	Component	Thickness Inches (mm)	Conductivity Btu-in / ft ² ·hr·°F (W/m K)	Nominal Resistance hr·ft ² ·°F/Btu (m ² K/W)	Density lb/ft ³ (kg/m ³)	Specific Heat Btu/lb·°F (J/kg K)
1	Interior Film ¹	-	-	R-0.6 to R-0.9 (0.11 RSI to 0.16 RSI)	-	-
2	Gypsum Board	1/2" (13)	1.1 (0.16)	R-0.5 (0.08 RSI)	50 (800)	0.26 (1090)
3	1 5/8" x 1 5/8" Steel Studs with Top and Bottom Tracks	18 Gauge	430 (62)	-	489 (7830)	0.12 (500)
4	Air in Stud Cavity	1 5/8" (41)	-	R-0.9 (0.16 RSI)	0.075 (1.2)	0.24 (1000)
5	Continuous Insulation	2 1/2" (64)	0.2 (0.029)	R-12.5 (2.20 RSI)	1.8 (28)	0.29 (1220)
6	Concrete Wall	8" (203)	12.5 (1.8)	R-0.64 (0.11 RSI)	140 (2250)	0.20 (850)
7	Concrete Slab	8" (203)	12.5 (1.8)	-	140 (2250)	0.20 (850)
8	Stainless Steel Reinforcement	-	118 (17)	-	503 (8060)	0.12 (500)
9	Polystyrene Hard Foam Insulation	2 3/8" (60)	0.217 (0.031)	R-10.9 (1.93 RSI)	66 (1060)	0.35 (1500)
10	Cement Board	1/2" (13)	1.7 (0.25)	-	72 (1150)	0.20 (850)
11	Exterior Film ¹	-	-	R-0.2 (0.03 RSI)	-	-

¹ Value selected from table 1, p. 26.1 of 2009 ASHRAE Handbook – Fundamentals depending on surface orientation

Detail 7.2.21

Highly Insulated Precast Concrete Sandwich Panel Wall Assembly – Intermediate Floor Intersection with Inner Wythe Supported by Concrete Floor

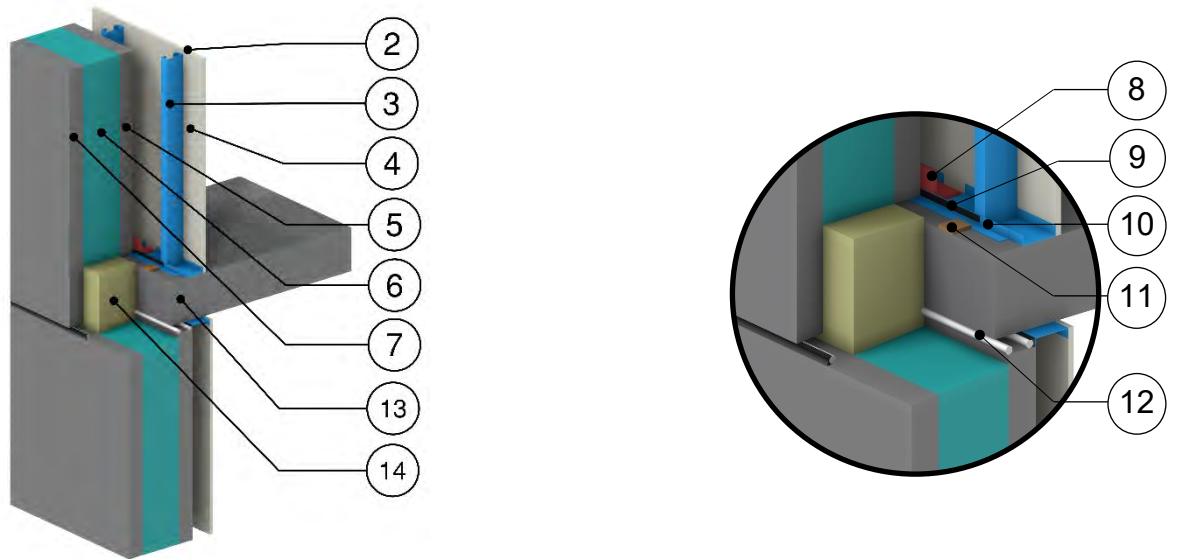

ID	Component	Thickness Inches (mm)	Conductivity Btu-in / ft ² ·hr·°F (W/m K)	Nominal Resistance hr·ft ² ·°F/Btu (m ² K/W)	Density lb/ft ³ (kg/m ³)	Specific Heat Btu/lb·°F (J/kg K)
1	Interior Film ¹	-	-	R-0.7 (0.12 RSI)	-	-
2	Gypsum Board	5/8" (15)	1.1 (0.16)	R-0.5 (0.09 RSI)	50 (800)	0.26 (1090)
3	3 5/8" x 1 5/8" Steel Studs with Top and Bottom Tracks	18 Gauge	430 (62)	-	489 (7830)	0.12 (500)
4	Air in Stud Cavity	3 5/8" (92)	-	R-0.9 (0.16 RSI)	0.075 (1.2)	0.24 (1000)
5	Precast Sandwich Panel, Interior Concrete Panel	3" (76)	12.5 (1.8)	-	140 (2250)	0.20 (850)
6	Precast Sandwich Panel Insulation	8" (203)	-	R-40 (7.04 RSI) to R-56 (9.86 RSI)	1.8 (28)	0.29 (1220)
7	Precast Sandwich Panel, Exterior Concrete Panel	3" (76)	12.5 (1.8)	-	140 (2250)	0.20 (850)
8	Anchor	-	347 (50)	-	489 (7830)	0.12 (500)
9	Sealant	-	1.73 (0.25)	-	-	-
10	Angle	-	430 (62)	-	489 (7830)	0.12 (500)
11	Shims	-	0.69 (0.1)	-	-	-
12	Backer Rod	-	0.25 (0.036)	-	-	-
13	Concrete Floor Slab	8" (203)	12.5 (1.8)	-	140 (2250)	0.20 (850)
14	Mineral Wool Slab Insulation	8" (203)	0.238 (0.034)	R-33.6 (5.92 RSI)	4 (64)	0.20 (850)
15	Exterior Film ¹	-	-	R-0.2 (0.03 RSI)	-	-

¹ Value selected from table 1, p. 26.1 of 2009 ASHRAE Handbook – Fundamentals depending on surface orientation

Detail 7.2.22

Owens Corning Exterior Insulated Concrete Block Wall Assembly with Shelf Angle and Heckmann Pos-I-Tie Veneer Anchoring System Supporting Brick Veneer – Intermediate Floor Intersection

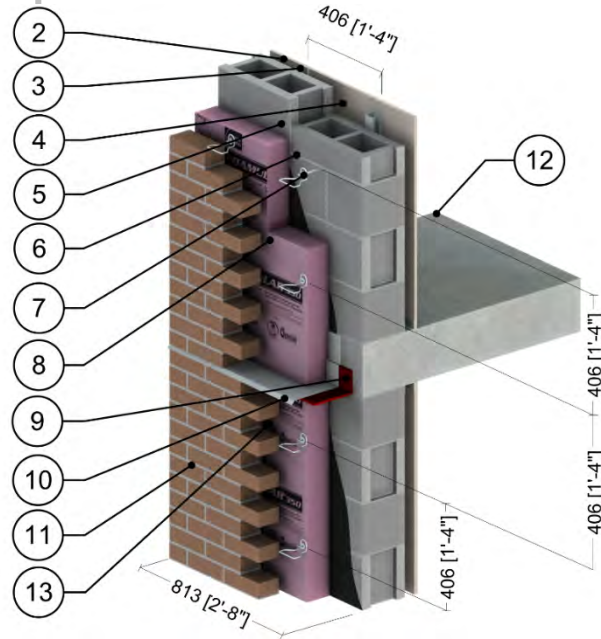

ID	Component	Thickness Inches (mm)	Conductivity Btu-in / ft ² -hr-°F (W/m K)	Nominal Resistance hr-ft ² -°F/Btu (m ² K/W)	Density lb/ft ³ (kg/m ³)	Specific Heat Btu/lb-°F (J/kg K)
1	Interior Film ¹	-	-	R-0.6 to R-0.9 (0.11 to 0.16 RSI)	-	-
2	Gypsum Board	1/2" (13)	1.1 (0.16)	R-0.5 (0.08 RSI)	50 (800)	0.26 (1090)
3	1 5/8" Steel Studs with Metal Tracks	20 gauge	430 (62)	-	489 (7830)	0.12 (500)
4	Air in Stud Cavity	1 5/8" (41)	-	R-0.9 (0.16 RSI)	0.075 (1.2)	0.24 (1000)
5	Standard Concrete Block	7 5/8" (190)	3.5 (0.5)	-	119 (1900)	0.19 (800)
6	Cement Mortar	-	3.5 (0.5)	-	113 (1800)	0.12 (500)
7	Heckmann Pos-I-Tie Masonry Tie @ 16" (406) o.c.	varies	-	-	-	-
8	Foamular CodeBord/C-200 Extruded Polystyrene (XPS) Rigid Insulation Type 3	varies	0.20 (0.029)	R-10 to R-20 (1.76 to 3.52 RSI)	1.8 (28)	0.29 (1220)
9	Steel Shelf Angle	3/8" (10)	347 (50)	-	489 (7830)	0.12 (500)
10	Metal Flashing	20 gauge	430 (62)	-	489 (7830)	0.12 (500)
11	Brick Veneer	3 5/8" (92)	5.4 (0.78)	-	120 (1920)	0.19 (720)
12	Concrete Slab	8" (203)	12.5 (1.8)	-	140 (2250)	0.20 (850)
13	Vented Air Gap ²	1" (25)	-	R-0.9 (0.16 RSI)	0.075 (1.2)	0.24 (1000)
14	Exterior Film ¹	-	-	R-0.2 (0.03 RSI)	-	-

¹ Value selected from table 1, p. 26.1 of 2009 ASHRAE Handbook – Fundamentals depending on surface orientation

² The thermal conductivity of air spaces was found using ISO 100077-2

Detail 7.2.23

Owens Corning Exterior Insulated Concrete Block Wall Assembly with Stainless Steel Stand-off Shelf Angle and Heckmann Pos-I-Tie Veneer Anchoring System Supporting Brick Veneer – Intermediate Floor Intersection

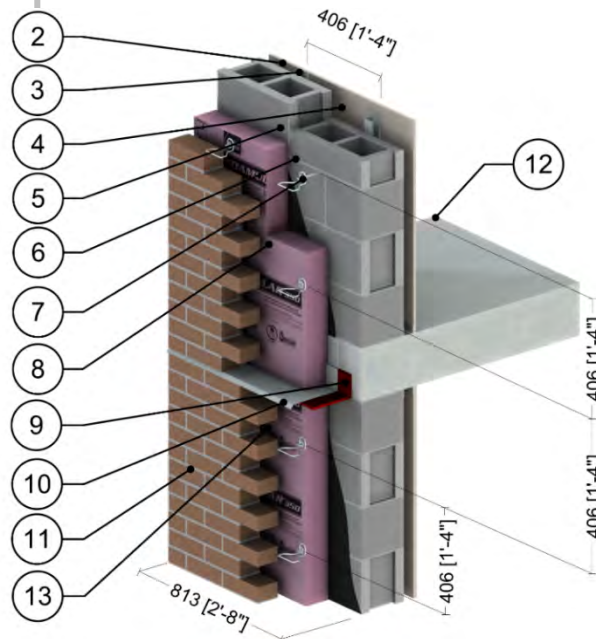

ID	Component	Thickness Inches (mm)	Conductivity Btu-in / ft ² -hr-°F (W/m K)	Nominal Resistance hr-ft ² -°F/Btu (m ² K/W)	Density lb/ft ³ (kg/m ³)	Specific Heat Btu/lb-°F (J/kg K)
1	Interior Film ¹	-	-	R-0.6 to R-0.9 (0.11 to 0.16 RSI)	-	-
2	Gypsum Board	1/2" (13)	1.1 (0.16)	R-0.5 (0.08 RSI)	50 (800)	0.26 (1090)
3	1 5/8" Steel Studs with Metal Tracks	20 gauge	430 (62)	-	489 (7830)	0.12 (500)
4	Air in Stud Cavity	1 5/8" (41)	-	R-0.9 (0.16 RSI)	0.075 (1.2)	0.24 (1000)
5	Standard Concrete Block	7 5/8" (190)	3.5 (0.5)	-	119 (1900)	0.19 (800)
6	Cement Mortar	-	3.5 (0.5)	-	113 (1800)	0.12 (500)
7	Heckmann Pos-I-Tie Masonry Tie @ 16" (406) o.c.	varies	-	-	-	-
8	Foamular CodeBord/C-200 Extruded Polystyrene (XPS) Rigid Insulation Type 3	varies	0.20 (0.029)	R-10 to R-20 (1.76 to 3.52 RSI)	1.8 (28)	0.29 (1220)
9	Stainless Steel Stand-off Shelf Angle	3/8" (10)	118 (17)	-	503 (8060)	0.12 (500)
10	Flashing	20 gauge	430 (62)	-	489 (7830)	0.12 (500)
11	Brick Veneer	3 5/8" (92)	5.4 (0.78)	-	120 (1920)	0.19 (720)
12	Concrete Slab	8" (203)	12.5 (1.8)	-	140 (2250)	0.20 (850)
13	Vented Air Gap ²	1" (25)	-	R-0.9 (0.16 RSI)	0.075 (1.2)	0.24 (1000)
14	Exterior Film ¹	-	-	R-0.2 (0.03 RSI)	-	-

¹ Value selected from table 1, p. 26.1 of 2009 ASHRAE Handbook – Fundamentals depending on surface orientation

² The thermal conductivity of air spaces was found using ISO 100077-2

Detail 7.2.24

Exterior Insulated Concrete Mass Wall with 1 5/8" x 1 5/8" Steel Stud (16" o.c.) and Thermally Isolated Vertical Brackets and Rail System (24" o.c.) Supporting Metal Cladding – Intermediate Floor Intersection

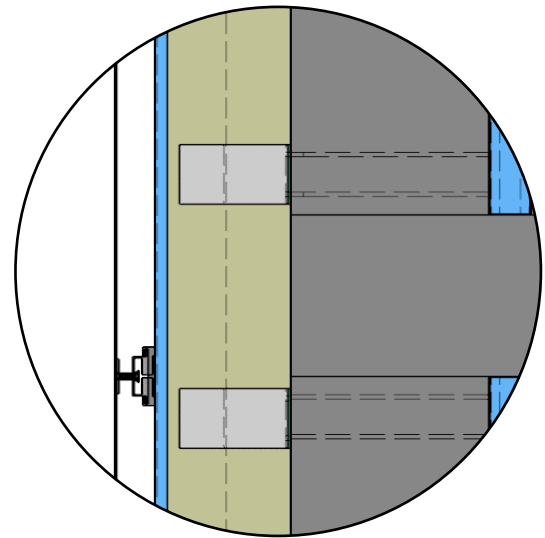
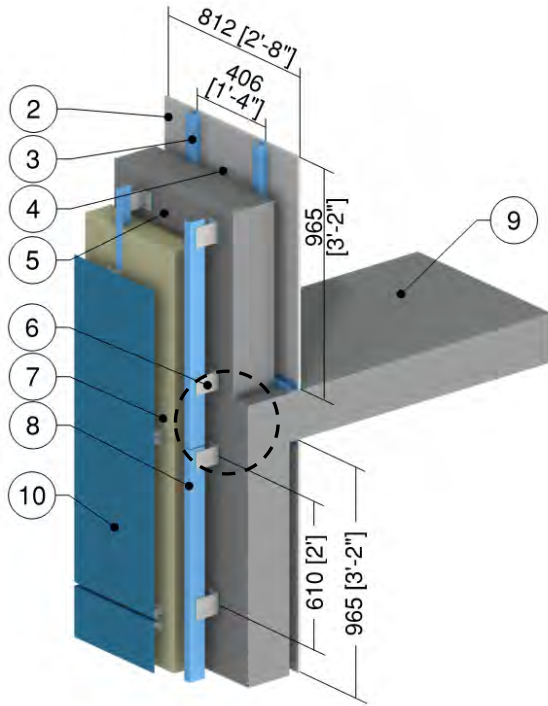

Slab Detail

ID	Component	Thickness Inches (mm)	Conductivity Btu-in / ft ² ·hr·°F (W/m K)	Nominal Resistance hr·ft ² ·°F/Btu (m ² K/W)	Density lb/ft ³ (kg/m ³)	Specific Heat Btu/lb·°F (J/kg K)
1	Interior Film ¹	-	-	R-0.6 to R-0.9 (0.11 RSI to 0.16 RSI)	-	-
2	Gypsum Board	1/2" (13)	1.1 (0.16)	R-0.5 (0.08 RSI)	50 (800)	0.26 (1090)
3	1 5/8" x 1 5/8" Steel Studs (16" o.c.) with Top and Bottom Tracks	20 Gauge	430 (62)	-	489 (7830)	0.12 (500)
4	Air in Stud Cavity	1 5/8" (41)	-	R-0.9 (0.16 RSI)	0.075 (1.2)	0.24 (1000)
5	Concrete Wall	8" (203)	12.5 (1.8)	-	140 (2250)	0.20 (850)
6	Thermally Isolated Aluminum Bracket	0.09" (2.2)	1109 (160)	-	171 (2739)	0.21 (900)
7	Exterior Insulation	Varies	-	R-10 to R-25 (1.76 RSI to 4.40 RSI)	1.8 (28)	0.29 (1220)
8	Vertical Aluminum L-girt	0.09" (2.2)	1109 (160)	-	171 (2739)	0.21 (900)
9	Concrete Floor Slab	8" (203)	12.5 (1.8)	-	140 (2250)	0.20 (850)
10	Generic Cladding with 1/2" (13mm) vented air space is incorporated into exterior heat transfer coefficient					
11	Exterior Film ¹	-	-	R-0.7 (0.12 RSI)	-	-

¹ Value selected from table 1, p. 26.1 of 2009 ASHRAE Handbook – Fundamentals depending on surface orientation



Detail 7.2.25

Highly Insulated Precast Concrete Sandwich Panel Wall Assembly – Intermediate Floor Intersection with Inner Wythe Supported by Concrete Floor

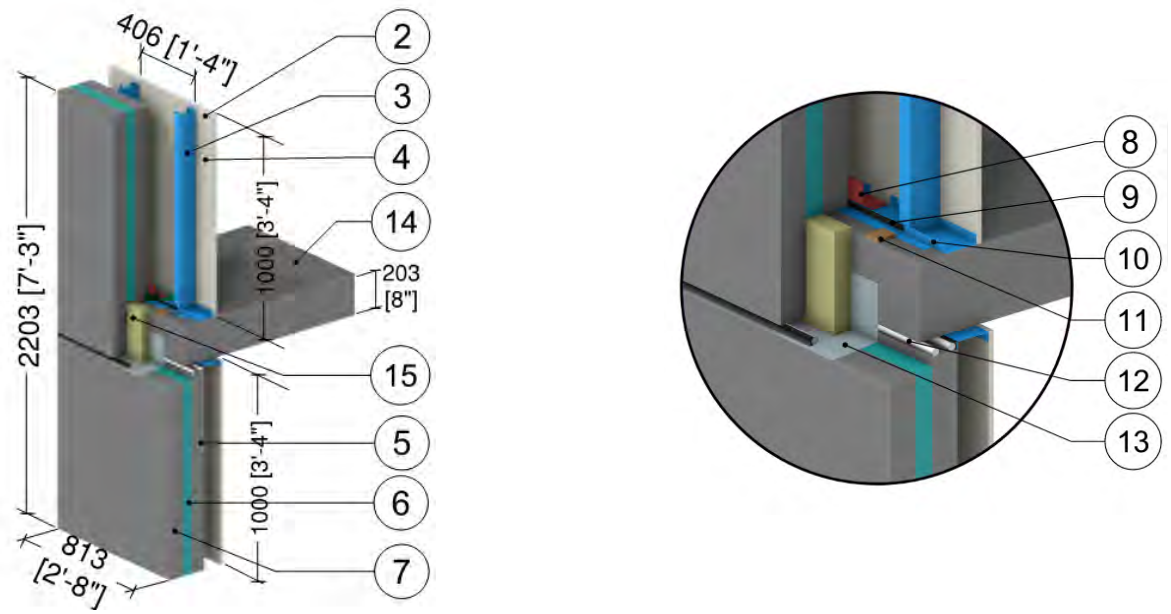

ID	Component	Thickness Inches (mm)	Conductivity Btu-in / ft ² ·hr·°F (W/m K)	Nominal Resistance hr·ft ² ·°F/Btu (m ² K/W)	Density lb/ft ³ (kg/m ³)	Specific Heat Btu/lb·°F (J/kg K)
1	Interior Film ¹	-	-	R-0.7 (0.12 RSI)	-	-
2	Gypsum Board	5/8" (15)	1.1 (0.16)	R-0.5 (0.09 RSI)	50 (800)	0.26 (1090)
3	3 5/8" x 1 5/8" Steel Studs with Top and Bottom Tracks	18 Gauge	430 (62)	-	489 (7830)	0.12 (500)
4	Air in Stud Cavity	3 5/8" (92)	-	R-0.9 (0.16 RSI)	0.075 (1.2)	0.24 (1000)
5	Precast Sandwich Panel, Interior Concrete Panel	4" (102)	12.5 (1.8)	-	140 (2250)	0.20 (850)
6	Precast Sandwich Panel Insulation	Varies	-	R-10 to R-20 (1.76 RSI to 3.52 RSI)	1.8 (28)	0.29 (1220)
7	Precast Sandwich Panel, Exterior Concrete Panel	4" (102)	12.5 (1.8)	-	140 (2250)	0.20 (850)
8	Anchor	-	347 (50)	-	489 (7830)	0.12 (500)
9	Sealant	-	1.73 (0.25)	-	-	-
10	Angle	-	430 (62)	-	489 (7830)	0.12 (500)
11	Shims	-	0.69 (0.1)	-	-	-
12	Backer Rod	-	0.25 (0.036)	-	-	-
13	Flashing	18 Gauge	1110 (160)	-	171 (2739)	0.22 (900)
14	Concrete Floor Slab	8" (203)	12.5 (1.8)	-	140 (2250)	0.20 (850)
15	Mineral Wool Slab Insulation	Varies	0.238 (0.034)	R-8.4 to R-16.8 (1.48 RSI to 2.96 RSI)	4 (64)	0.20 (850)
16	Exterior Film ¹	-	-	R-0.2 (0.03 RSI)	-	-

¹ Value selected from table 1, p. 26.1 of 2009 ASHRAE Handbook – Fundamentals depending on surface orientation



Detail 7.3.1

Exterior Insulated Concrete Drained EIFS Wall Assembly – Window and Intermediate Floor Intersection

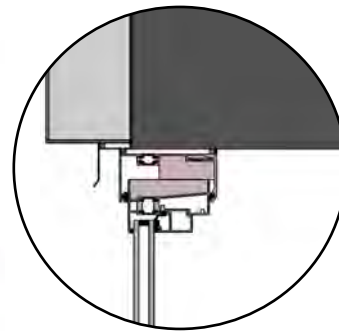
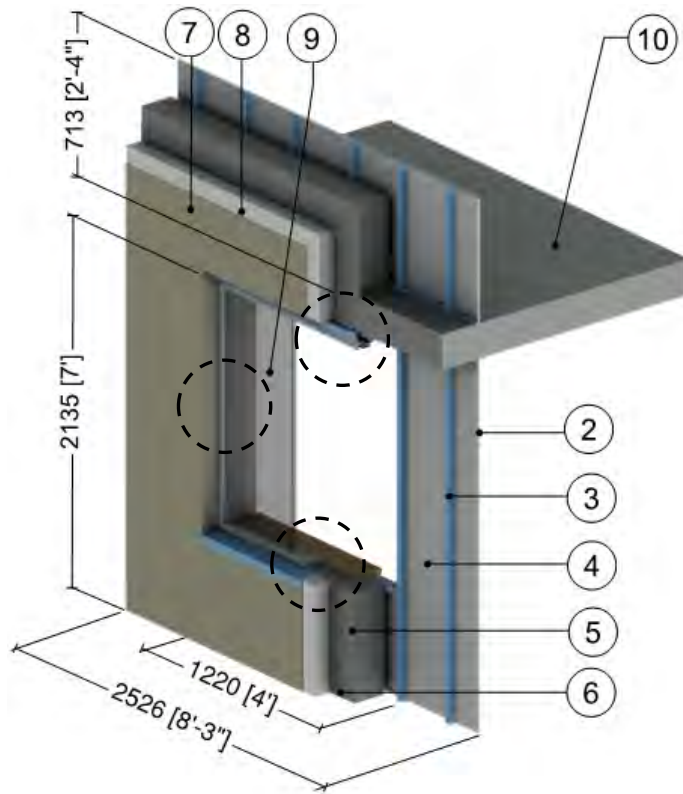

Head Detail

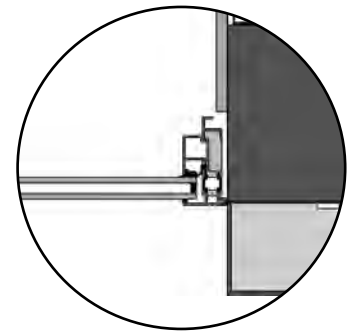

Jamb Detail

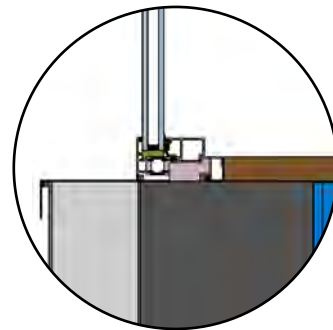

Sill Detail

ID	Component	Thickness Inches (mm)	Conductivity Btu-in / ft ² ·hr·°F (W/m K)	Nominal Resistance hr·ft ² ·°F/Btu (m ² K/W)	Density lb/ft ³ (kg/m ³)	Specific Heat Btu/lb·°F (J/kg K)
1	Interior Films ¹	-	-	R-0.6 to R-0.9 (0.11 RSI to 0.16 RSI)	-	-
2	Gypsum Board	1/2" (13)	1.1 (0.16)	R-0.5 (0.08 RSI)	50 (800)	0.26 (1090)
3	1 5/8" x 1 5/8" Steel Studs (16"o.c.) with Top and Bottom Tracks	18 Gauge	430 (62)	-	489 (7830)	0.12 (500)
4	Air in Stud Cavity	1 5/8" (41)	-	R-0.9 (0.16 RSI)	0.075 (1.2)	0.24 (1000)
5	Concrete Wall	8" (203)	12.5 (1.8)	-	140 (2250)	0.20 (850)
6	Weather Resistive Barrier with Adhesive	-	-	-	-	-
7	Lamina	1/8" (4)	6 (0.9)	R-0.04 (0.01 RSI)	120 (1922)	0.20 (850)
8	Insulation Board	4" (100)	0.27 (0.039)	R-15 (2.64 RSI)	1.2 (20)	0.35 (1470)
9	5' (1.5m) x 6' (1.8m) Aluminum window: double glazed & thermally broken ² , double glazed IGU U _{IGU} = 0.32 BTU/hr.ft ² ·°F (1.82 W/m ² K)					
10	Concrete Slab	8" (203)	12 (1.8)	-	140 (2250)	0.20 (850)
11	Exterior Film ¹	-	-	R-0.2 (0.03 RSI)	-	-

¹ Value selected from table 1, p. 26.1 of 2009 ASHRAE Handbook – Fundamentals depending on surface orientation

² The thermal conductivity of air spaces within framing was found using ISO 100077-2

Detail 7.3.2

Interior Insulated Concrete Mass Wall with 1 5/8" x 1 5/8" Steel Studs (16" o.c.) Supporting Interior Finish – Window & Intermediate Floor Intersection

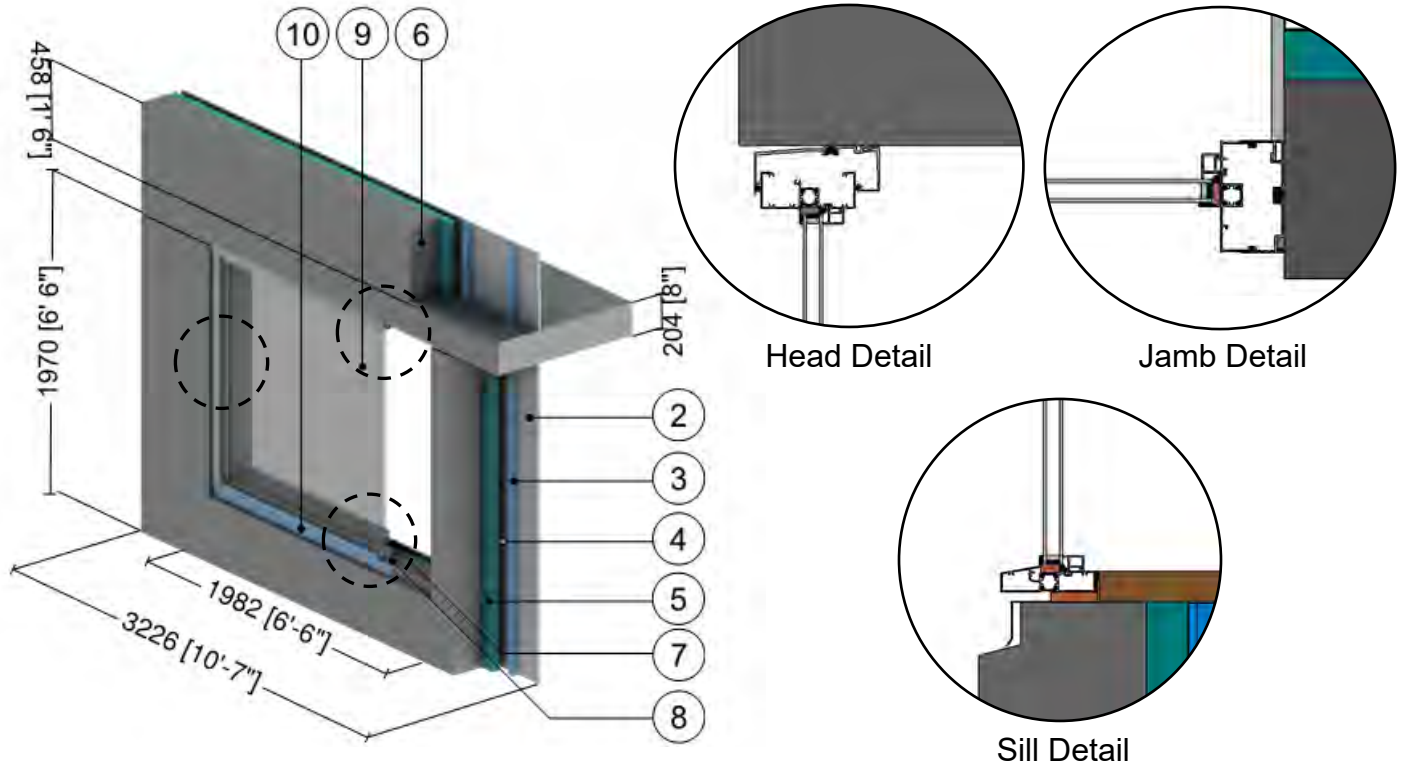

ID	Component	Thickness Inches (mm)	Conductivity Btu-in / ft ² ·hr·°F (W/m K)	Nominal Resistance hr·ft ² ·°F/Btu (m ² K/W)	Density lb/ft ³ (kg/m ³)	Specific Heat Btu/lb·°F (J/kg K)
1	Interior Films ¹	-	-	R-0.6 to R-0.9 (0.11 RSI to 0.16 RSI)	-	-
2	Gypsum Board	1/2" (13)	1.1 (0.16)	R-0.5 (0.08 RSI)	50 (800)	0.26 (1090)
3	1 5/8" x 1 5/8" Steel Studs with Top and Bottom Tracks	18 Gauge	430 (62)	-	489 (7830)	0.12 (500)
4	Air in Stud Cavity	1 5/8" (92)	-	R-0.9 (RSI-0.16)	0.075 (1.2)	0.24 (1000)
5	Continuous Insulation	Varies	-	R-10 to R-15 (1.76 RSI to 2.64 RSI)	1.8 (28)	0.29 (1220)
6	Concrete Wall/Floor Slab	8" (203)	12.5 (1.8)	-	140 (2250)	0.20 (850)
7	Steel Sheet Connected to Studs	18 Gauge	430 (62)	-	489 (7830)	0.12 (500)
8	Wood Sill	1 1/4" (30)	0.69 (0.10)	-	27.8 (445)	0.45 (1880)
9	5' (1.5m) x 6' (1.8m) Aluminum window: double glazed & thermally broken ² , double glazed IGU U _{IGU} = 0.32 BTU/hr.ft ² ·°F (1.82 W/m ² K)					
10	Aluminum Flashing	16 Gauge	1109 (160)	-	171(2739)	0.21 (900)
11	Exterior Film ¹	-	-	R-0.2 (0.03 RSI)	-	-

¹ Value selected from table 1, p. 26.1 of 2009 ASHRAE Handbook – Fundamentals depending on surface orientation

² The thermal conductivity of air spaces within framing was found using ISO 100077-2.

Detail 7.3.3

Interior Insulated Concrete Mass Wall with 1 5/8" x 1 5/8" Steel Studs (16" o.c.) Supporting Interior Finish – Window & Intermediate Floor Intersection with Project Slab

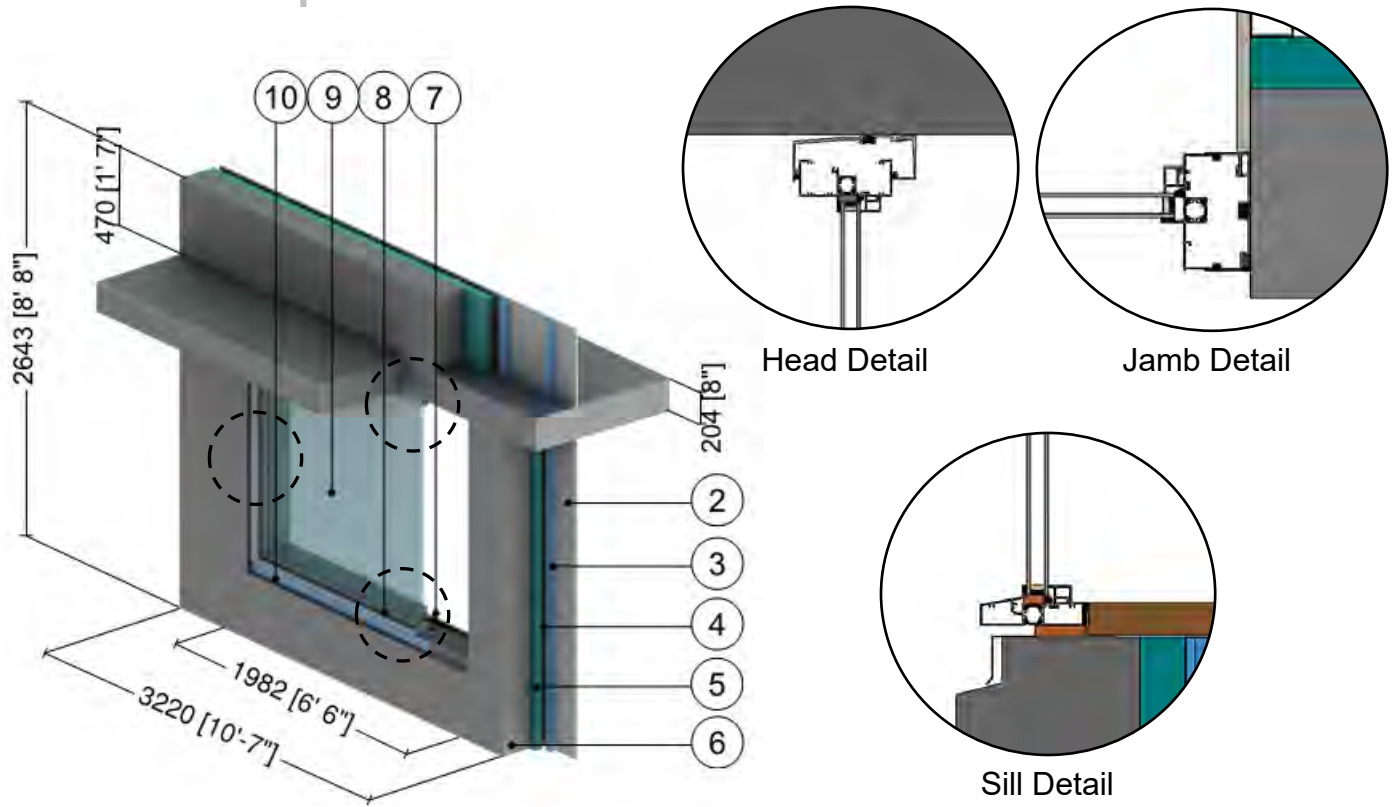

ID	Component	Thickness Inches (mm)	Conductivity Btu-in / ft ² ·hr·°F (W/m K)	Nominal Resistance hr·ft ² ·°F/Btu (m ² K/W)	Density lb/ft ³ (kg/m ³)	Specific Heat Btu/lb·°F (J/kg K)
1	Interior Film ¹	-	-	R-0.6 to R-1.1 (0.11 RSI to 0.20 RSI)	-	-
2	Gypsum Board	1/2" (13)	1.1 (0.16)	R-0.5 (0.08 RSI)	50 (800)	0.26 (1090)
3	1 5/8" x 1 5/8" Steel Studs with Top and Bottom Tracks	18 Gauge	430 (62)	-	489 (7830)	0.12 (500)
4	Air in Stud Cavity	1 5/8" (92)	-	R-0.9 (RSI-0.16)	0.075 (1.2)	0.24 (1000)
5	Continuous Rigid Insulation	Varies	-	R-10 to R-15 (1.76 RSI to 2.64 RSI)	1.8 (28)	0.29 (1220)
6	Concrete Wall/ Projected Floor Slab	8" (203)	12.5 (1.8)	-	140 (2250)	0.20 (850)
7	Steel Sheet Connected to Studs ³	18 Gauge	430 (62)	-	489 (7830)	0.12 (500)
8	Wood Sill	1 1/4" (30)	0.69 (0.1)	-	27.8 (445)	0.45 (1880)
9	5' (1.5m) x 6' (1.8m) Aluminum window: double glazed & thermally broken ² , double glazed IGU U _{IGU} = 0.32 BTU/hr.ft ² ·°F (1.82 W/m ² K)					
10	Aluminum Flashing	14 Gauge	1109 (160)	-	171 (2739)	0.21 (900)
11	Exterior Film ¹	-	-	R-0.2 (0.03 RSI)	-	-

¹ Value selected from table 1, p. 26.1 of 2009 ASHRAE Handbook – Fundamentals depending on surface orientation

² The thermal conductivity of air spaces within framing was found using ISO 100077-2

³ Scenarios C and D include sheet steel, Scenarios A and B do not.

Detail 7.3.4

Precast Sandwich Panel Wall Assembly with Concrete at Panel Perimeter and Steel Connectors at 24" (o.c.) – Window Intersection

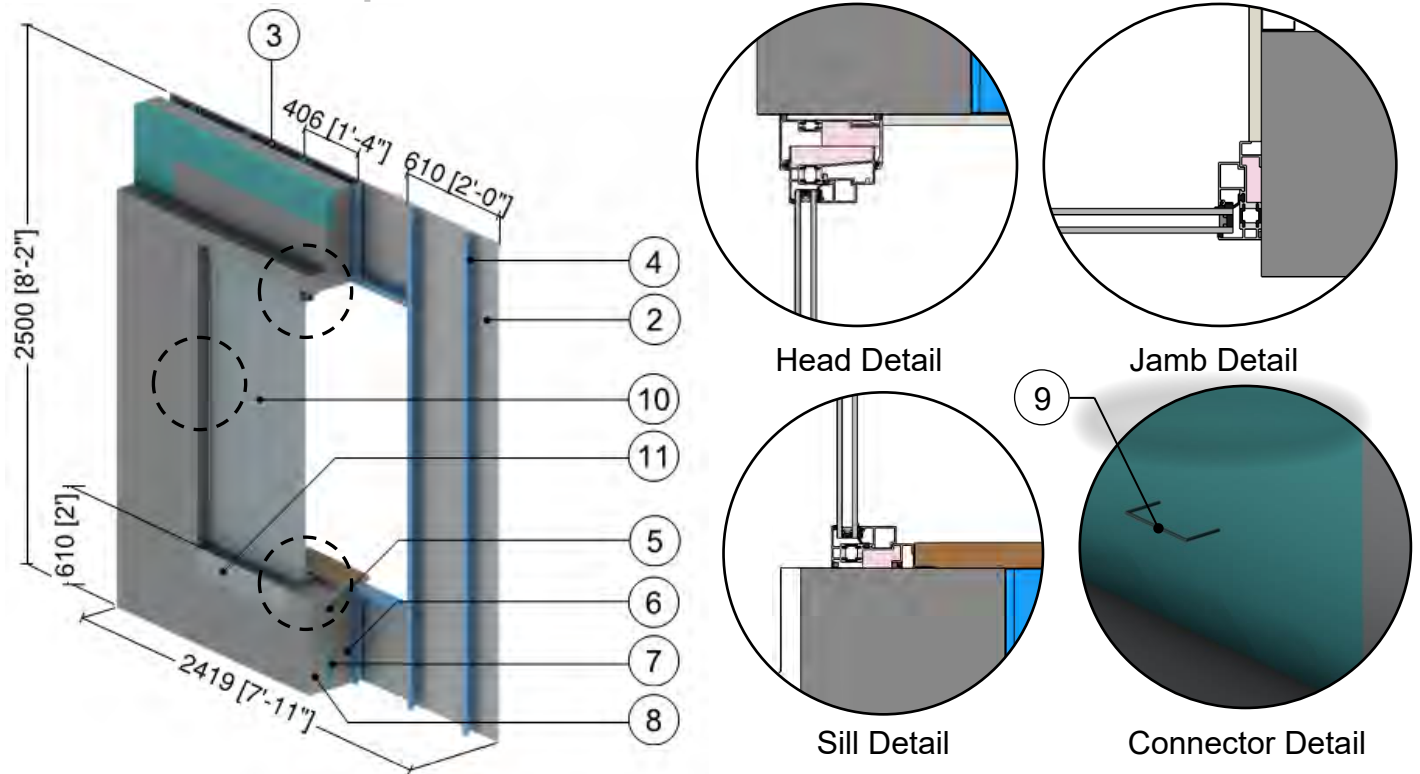

ID	Component	Thickness Inches (mm)	Conductivity Btu-in / ft ² ·hr·°F (W/m K)	Nominal Resistance hr·ft ² ·°F/Btu (m ² K/W)	Density lb/ft ³ (kg/m ³)	Specific Heat Btu/lb·°F (J/kg K)
1	Interior Film	-	-	R-0.7 to R-1.1 (0.12 RSI to 0.20 RSI)	-	-
2	Gypsum Board	1/2" (13)	1.1 (0.16)	R-0.5 (0.08 RSI)	50 (800)	0.26 (1090)
3	Air in Stud Cavity	3 5/8" (143)	-	R-0.9 (0.16 RSI)	0.075 (1.2)	0.24 (1000)
4	3 5/8" Steel Studs with Top and Bottom Tracks	18 Gauge	430 (62)	-	489 (7830)	0.12 (500)
5	Concrete at Window Perimeter	12" (304)	12.5 (1.8)	-	140 (2250)	0.20 (850)
6	Precast Sandwich Panel, Interior Concrete	4" (102)	12.5 (1.8)	-	140 (2250)	0.20 (850)
7	Precast Sandwich Panel, Insulation	2" (51)	-	R-10 (1.76 RSI)	1.8 (28)	0.29 (1220)
8	Precast Sandwich Panel, Exterior Concrete	4" (102)	12.5 (1.8)	-	140 (2250)	0.20 (850)
9	Precast Sandwich Panel, Steel Structural Ties @ 24" (914) o.c.	16 Gauge	430 (62)	-	489 (7830)	0.12 (500)
10	5' (1.5m) x 6' (1.8m) Aluminum window: double glazed & thermally broken ² , double glazed IGU U _{IGU} = 0.32 BTU/hr.ft ² ·°F (1.82 W/m ² K)					
11	Steel Flashing	18 Gauge	430 (62)	-	489 (7830)	0.12 (500)
12	Exterior Film	-	-	R-0.2 (0.03 RSI)	-	-

¹ Value selected from table 1, p. 26.1 of 2009 ASHRAE Handbook – Fundamentals depending on surface orientation

² The thermal conductivity of air spaces within framing was found using ISO 100077-2



Detail 7.3.5

Precast Sandwich Panel Wall Assembly with Steel Connectors at 24" (o.c.), and 3 5/8" Steel Stud (16" o.c.) – Window Intersection

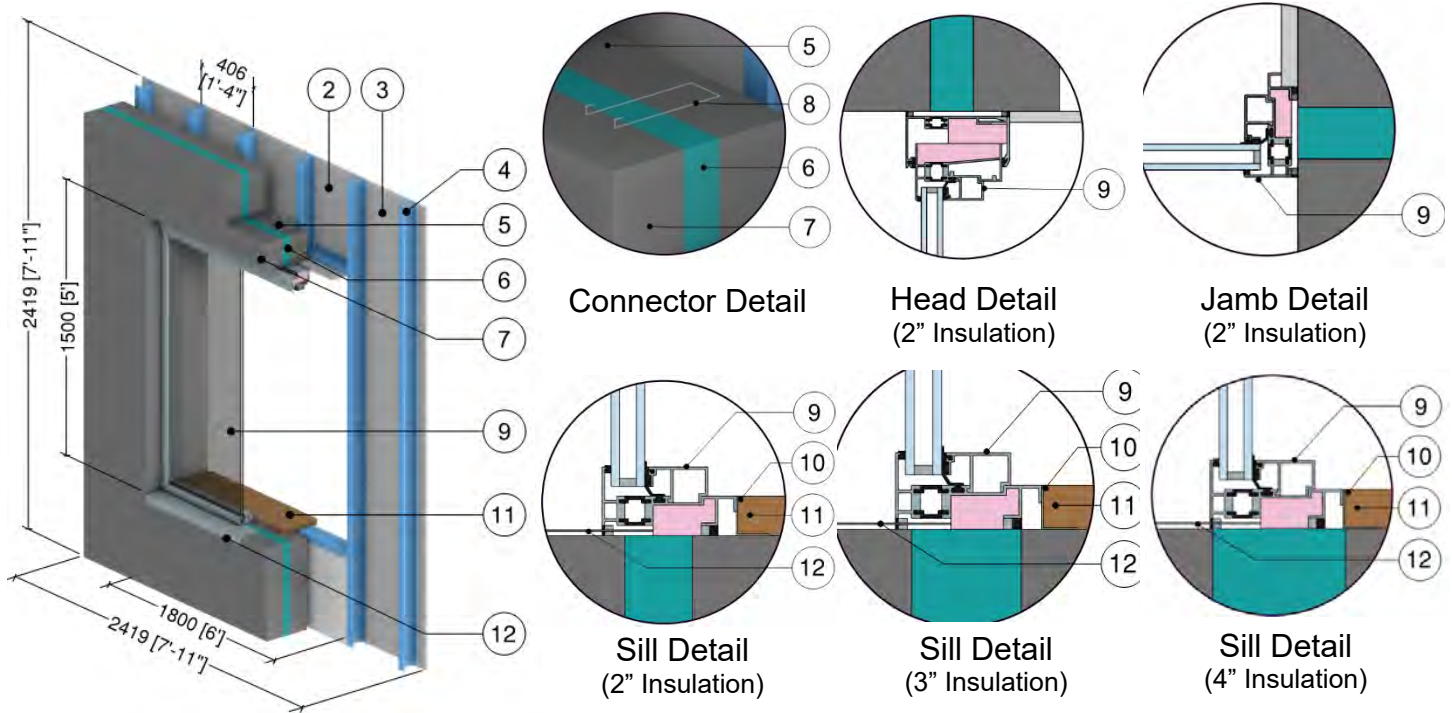

ID	Component	Thickness Inches (mm)	Conductivity Btu·in / ft ² ·hr·°F (W/m K)	Nominal Resistance hr·ft ² ·°F/Btu (m ² K/W)	Density lb/ft ³ (kg/m ³)	Specific Heat Btu/lb·°F (J/kg K)
1	Interior Film ¹	-	-	R-0.7 to R-1.1 (0.12 RSI to 0.20 RSI)	-	-
2	Gypsum Board	1/2" (13)	1.1 (0.16)	R-0.5 (0.08 RSI)	50 (800)	0.26 (1090)
3	Air in Stud Cavity	4.7" (120)	-	R-0.9 (0.16 RSI)	0.075 (1.2)	0.24 (1000)
4	3 5/8" Steel Studs with Metal Tracks	18 Gauge	430 (62)	-	489 (7830)	0.12 (500)
5	Precast Sandwich Panel, Interior Concrete	4" (102)	12.5 (1.8)	-	140 (2250)	0.20 (850)
6	Precast Sandwich Panel, Insulation	Varies	-	R-10 to R-20 (1.76 RSI to 3.52 RSI)	1.8 (28)	0.29 (1220)
7	Precast Sandwich Panel, Exterior Concrete	4" (102)	12.5 (1.8)	-	140 (2250)	0.20 (850)
8	Precast Sandwich Panel, Steel Connectors @ 24" (610) o.c.	16 Gauge	430 (62)	-	489 (7830)	0.12 (500)
9	1.5m (H) x 1.2m (W) Aluminum window: double glazed & thermally broken ²					
10	Sill Angle	18 Gauge	430 (62)	-	489 (7830)	0.12 (500)
11	Wood Sill	1 1/4" (30)	0.69 (0.10)	-	27.8 (445)	0.45 (1880)
12	Flashing	14 Gauge	430 (62)	-	489 (7830)	0.12 (500)
13	Exterior Film ¹	-	-	R-0.2 (0.03 RSI)	-	-

¹ Value selected from table 1, p. 26.1 of 2009 ASHRAE Handbook – Fundamentals depending on surface orientation

² The thermal conductivity of air spaces within framing was found using ISO 100077-2

Detail 7.3.6

Exterior Insulated Concrete Drained EIFS Wall Assembly – Window with Aerogel and Intermediate Floor Intersection

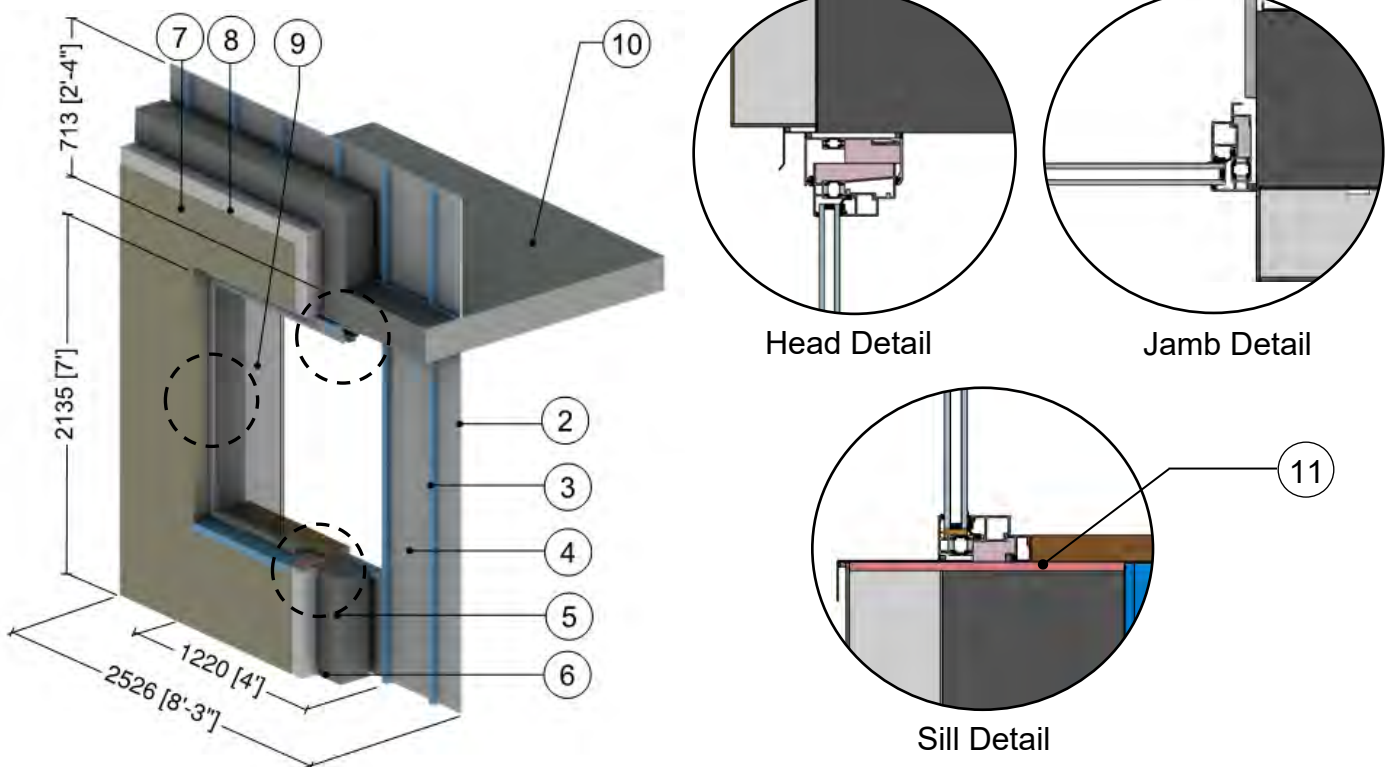

ID	Component	Thickness Inches (mm)	Conductivity Btu-in / ft ² ·hr·°F (W/m K)	Nominal Resistance hr·ft ² ·°F/Btu (m ² K/W)	Density lb/ft ³ (kg/m ³)	Specific Heat Btu/lb·°F (J/kg K)
1	Interior Films ¹	-	-	R-0.6 to R-0.9 (0.11 RSI to 0.16 RSI)	-	-
2	Gypsum Board	1/2" (13)	1.1 (0.16)	R-0.5 (0.08 RSI)	50 (800)	0.26 (1090)
3	1 5/8" x 1 5/8" Steel Studs (16" o.c.) with Top and Bottom Tracks	18 Gauge	430 (62)	-	489 (7830)	0.12 (500)
4	Air in Stud Cavity	1 5/8" (41)	-	R-0.9 (0.16 RSI)	0.075 (1.2)	0.24 (1000)
5	Concrete Wall	8" (203)	12.5 (1.8)	-	140 (2250)	0.20 (850)
6	Weather Resistive Barrier with Adhesive	-	-	-	-	-
7	Lamina	1/8" (4)	6 (0.9)	R-0.04 (0.01 RSI)	120 (1922)	0.20 (850)
8	Insulation Board	4" (100)	0.27 (0.039)	R-15 (2.64 RSI)	1.2 (20)	0.35 (1470)
9	5' (1.5m) x 6' (1.8m) Aluminum window: double glazed & thermally broken ² , double glazed IGU U _{IGU} = 0.32 BTU/hr.ft ² ·°F (1.82 W/m ² K)					
10	Concrete Slab	8" (203)	12 (1.8)	-	140 (2250)	0.20 (850)
11	Aerogel Blanket	3/8" (10)	0.1 (0.015)	R-3.8 (0.67 RSI)	-	-
12	Exterior Film ¹	-	-	R-0.2 (0.03 RSI)	-	-

¹ Value selected from table 1, p. 26.1 of 2009 ASHRAE Handbook – Fundamentals depending on surface orientation

² The thermal conductivity of air spaces within framing was found using ISO 100077-2

Detail 7.3.7

Interior Insulated Concrete Block or Concrete Wall Assembly with Brick Cladding – Window Intersection

Detail referenced from work done by Passive House Academy

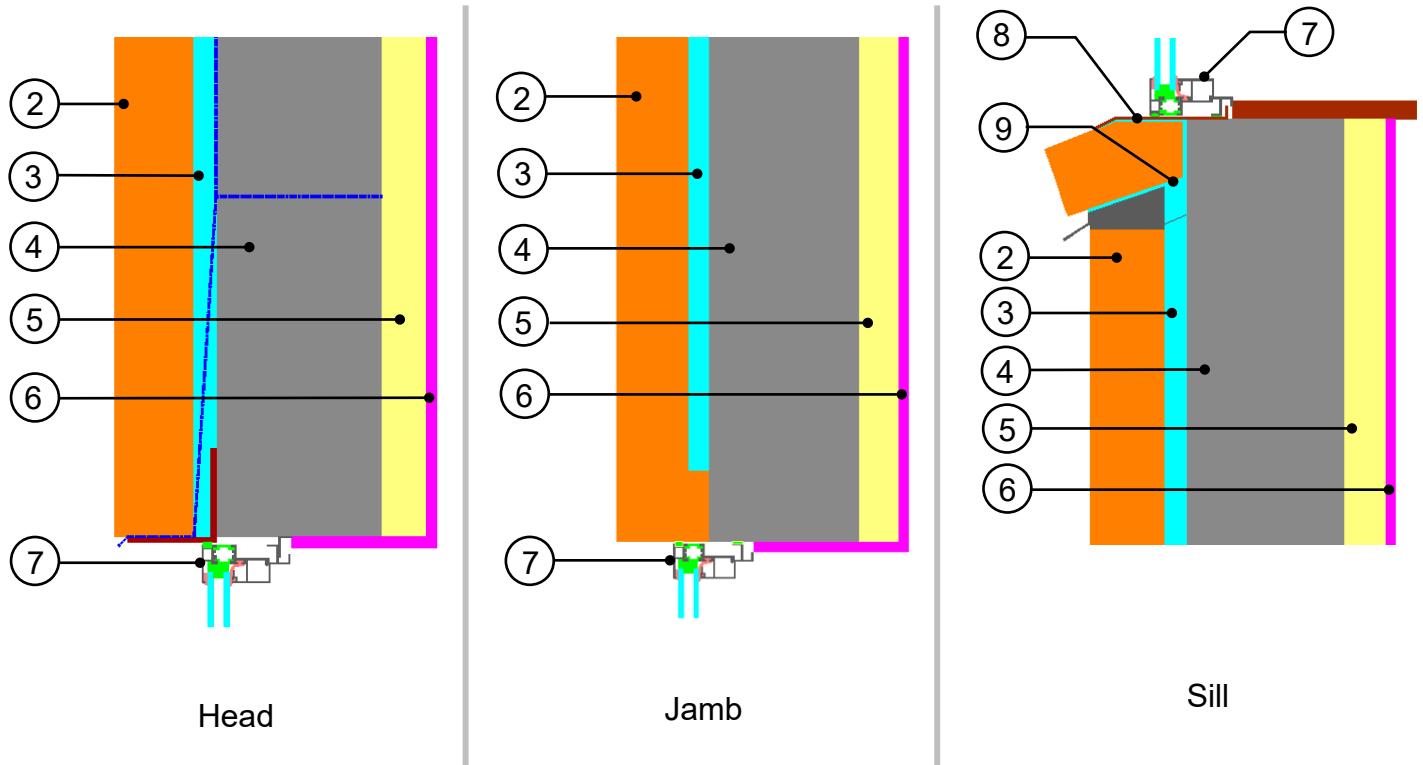

ID	Component	Thickness Inches (mm)	Conductivity Btu-in / ft ² ·hr·°F (W/m K)	Nominal Resistance hr·ft ² ·°F/Btu (m ² K/W)	Density lb/ft ³ (kg/m ³)	Specific Heat Btu/lb·°F (J/kg K)
1	Interior Films ¹	-	-	R-0.74 (0.13 RSI)	-	-
2	Brick	3 5/8" (92)	0.578 (1.0)	R-0.523 (0.092 RSI)	110 (1800)	-
3	Air Cavity	1" (25)	0.070 (0.122)	R-1.185 (0.209 RSI)	-	-
4	Concrete Block (CMU)	7 5/8" (194)	0.069 (1.2)	R-0.916 (0.161 RSI)	130 (2100)	-
5	Interior Insulation	2" (51)	0.0139 (0.024)	R12 (2.11 RSI)	-	-
6	Gypsum Board	1/2" (13)	0.092 (0.16)	R-0.5 (0.08 RSI)	50 (800)	-
7	5500 ISOWEB Window	-	-	-	-	-
8	Aluminum Sill Flashing	12 Gauge	92.45 (160)	-	-	-
9	Brick Sill	3 5/8" (92)	0.578 (1.0)	-	110 (1800)	-
10	Exterior Film ¹	-	-	R-0.23 (0.04 RSI)	-	-

¹ Value selected from table 1, p. 26.1 of 2009 ASHRAE Handbook – Fundamentals depending on surface orientation

Detail 7.3.8

Interior Insulated Concrete Block or Concrete Wall Assembly with Brick Cladding – Window Intersection Aligned with Insulation

Detail referenced from work done by Passive House Academy

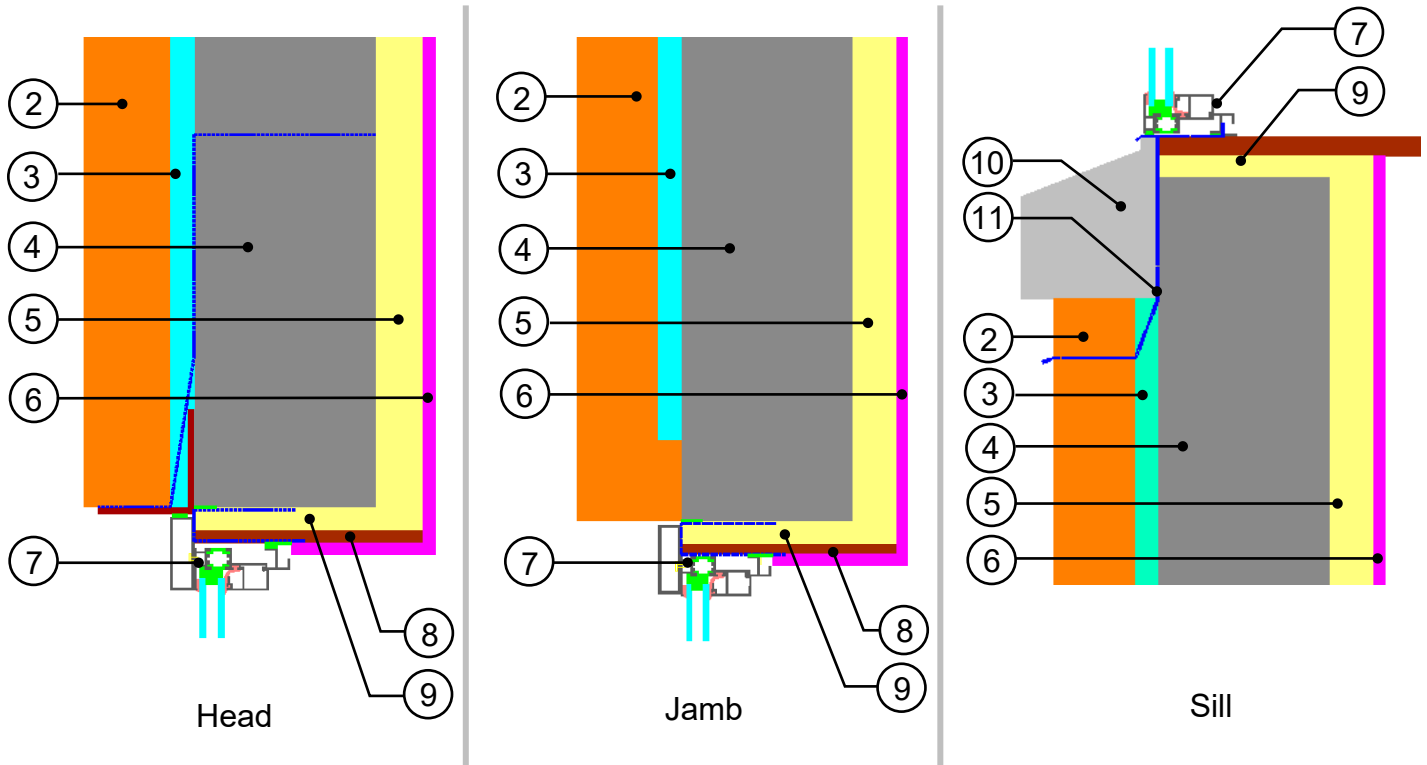

ID	Component	Thickness Inches (mm)	Conductivity Btu-in / ft ² ·hr·°F (W/m K)	Nominal Resistance hr·ft ² ·°F/Btu (m ² K/W)	Density lb/ft ³ (kg/m ³)	Specific Heat Btu/lb·°F (J/kg K)
1	Interior Films ¹	-	-	R-0.74 (0.13 RSI)	-	-
2	Brick	3 5/8" (92)	0.578 (1.0)	R-0.523 (0.092 RSI)	110 (1800)	-
3	Air Cavity	1" (25)	0.070 (0.122)	R-1.185 (0.209 RSI)	-	-
4	Concrete Block (CMU)	7 5/8" (194)	0.069 (1.2)	R-0.916 (0.161 RSI)	130 (2100)	-
5	Interior Insulation	2" (51)	0.0139 (0.024)	R12 (2.11 RSI)	-	-
6	Gypsum Board	1/2" (13)	0.092 (0.16)	R-0.5 (0.08 RSI)	50 (800)	-
7	5500 ISOWEB Window	-	-	-	-	-
8	Plywood Liner	3/4" (19)	0.058 (0.1)	-	-	-
9	Rigid Insulation	1" (25)	0.0139 (0.024)	-	-	-
10	Concrete Sill	-	1.4 (2.4)	-	110 (1800)	-
11	Aluminum Sill Flashing	12 Gauge	92.45 (160)	-	-	-
12	Exterior Film ¹	-	-	R-0.23 (0.04 RSI)	-	-

¹ Value selected from table 1, p. 26.1 of 2009 ASHRAE Handbook – Fundamentals depending on surface orientation

Detail 7.3.9

Interior Insulated Concrete Mass Wall with 1 5/8" x 1 5/8" Steel Studs (16" o.c.) Supporting Interior Finish – Window & Projected Slab Intersection with Plywood and Insulation Liner

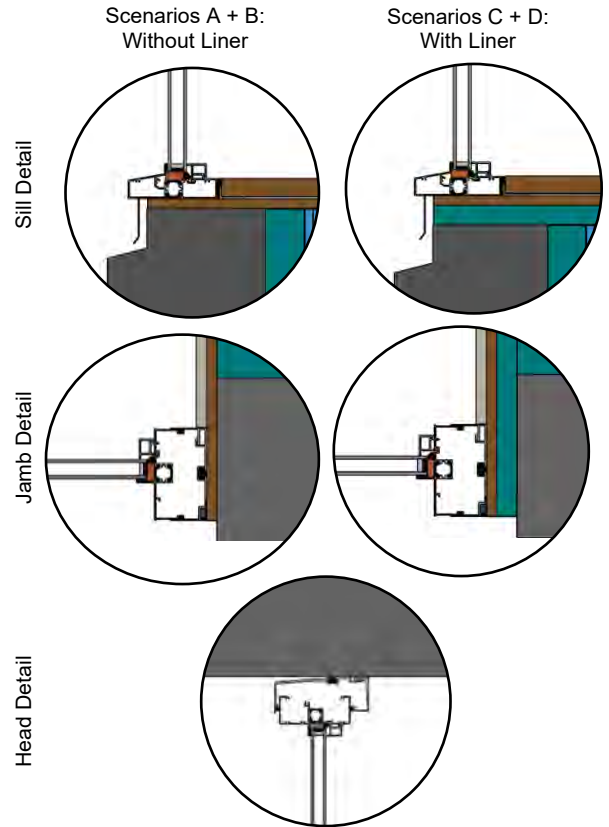
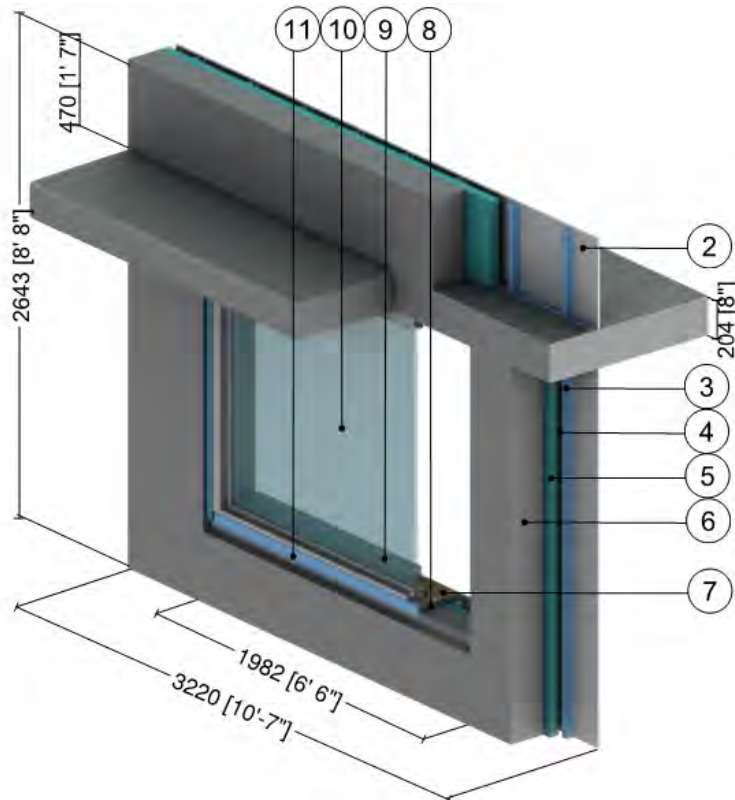

ID	Component	Thickness Inches (mm)	Conductivity Btu-in / ft ² ·hr·°F (W/m K)	Nominal Resistance hr·ft ² ·°F/Btu (m ² K/W)	Density lb/ft ³ (kg/m ³)	Specific Heat Btu/lb·°F (J/kg K)
1	Interior Film ¹	-	-	R-0.6 to R-1.1 (0.11 RSI to 0.20 RSI)	-	-
2	Gypsum Board	1/2" (13)	1.1 (0.16)	R-0.5 (0.08 RSI)	50 (800)	0.26 (1090)
3	1 5/8" x 1 5/8" Steel Studs with Top and Bottom Tracks	18 Gauge	430 (62)	-	489 (7830)	0.12 (500)
4	Air in Stud Cavity	1 5/8" (92)	-	R-0.9 (RSI-0.16)	0.075 (1.2)	0.24 (1000)
5	Continuous Rigid Insulation	Varies	-	R-10 to R-15 (1.76 RSI to 2.64 RSI)	1.8 (28)	0.29 (1220)
6	Concrete Wall/ Projected Floor Slab	8" (203)	12.5 (1.8)	-	140 (2250)	0.20 (850)
7	Plywood Liner	1/2" (13)	0.69 (0.1)	-	27.8 (445)	0.45 (1880)
8	Liner Insulation	Optional	-	R-5 (0.88 RSI)	1.8 (28)	0.29 (1220)
9	Wood Sill	1 1/4" (30)	0.69 (0.1)	-	27.8 (445)	0.45 (1880)
10	5' (1.5m) x 6' (1.8m) Aluminum window: double glazed & thermally broken ² , IGU U _{IGU} = 0.32 BTU/hr.ft ² ·°F (1.82 W/m ² K)					
11	Aluminum Flashing	14 Gauge	1109 (160)	-	171 (2739)	0.21 (900)
12	Exterior Film ¹	-	-	R-0.2 (0.03 RSI)	-	-

¹ Value selected from table 1, p. 26.1 of 2009 ASHRAE Handbook – Fundamentals depending on surface orientation

² The thermal conductivity of air spaces within framing was found using ISO 100077-2



Detail 7.3.10

Interior Insulated Concrete Mass Wall with 1 5/8" x 1 5/8" Steel Studs (16" o.c.) Supporting Interior Finish – Window & Projected Slab Intersection with Wall Insulation Wrapped into Opening

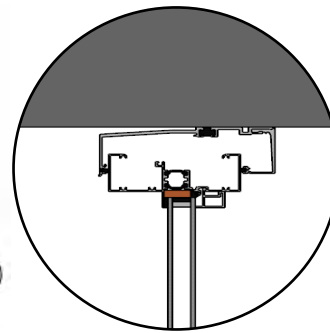
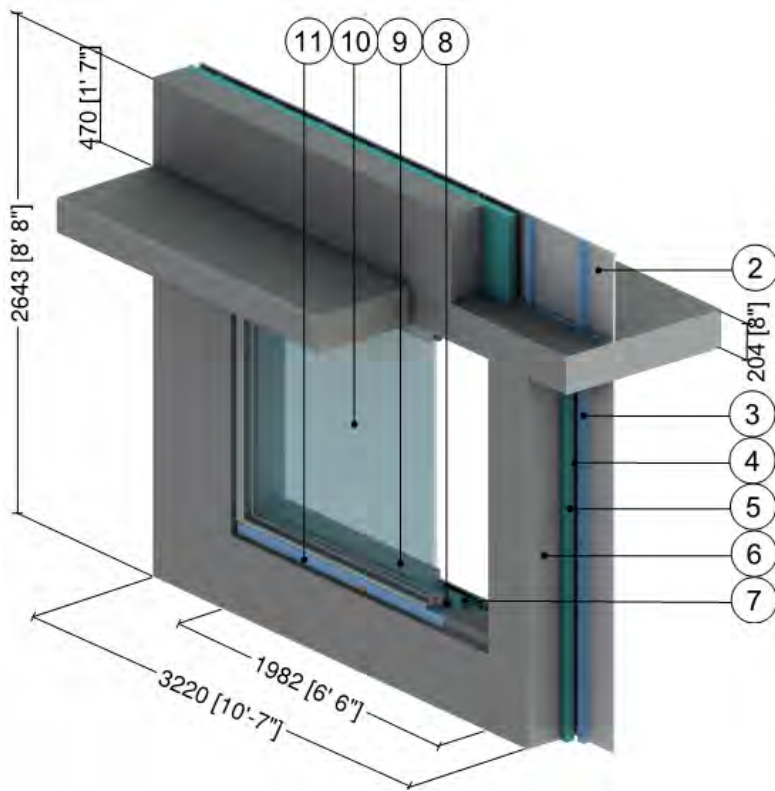

Head Detail

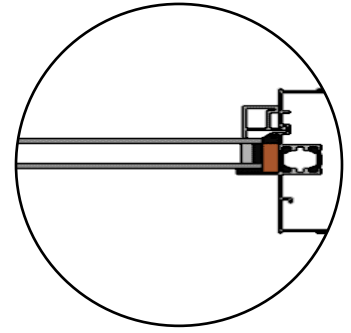

Jamb Detail

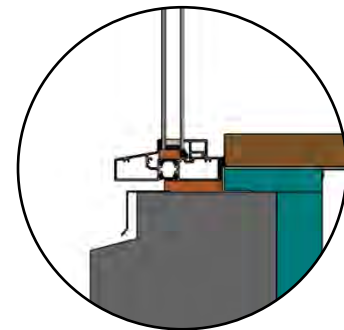

Sill Detail

ID	Component	Thickness Inches (mm)	Conductivity Btu-in / ft ² ·hr·°F (W/m K)	Nominal Resistance hr·ft ² ·°F/Btu (m ² K/W)	Density lb/ft ³ (kg/m ³)	Specific Heat Btu/lb·°F (J/kg K)
1	Interior Film ¹	-	-	R-0.6 to R-1.1 (0.11 RSI to 0.20 RSI)	-	-
2	Gypsum Board	1/2" (13)	1.1 (0.16)	R-0.5 (0.08 RSI)	50 (800)	0.26 (1090)
3	1 5/8" x 1 5/8" Steel Studs with Top and Bottom Tracks	18 Gauge	430 (62)	-	489 (7830)	0.12 (500)
4	Air in Stud Cavity	1 5/8" (92)	-	R-0.9 (RSI-0.16)	0.075 (1.2)	0.24 (1000)
5	Continuous Rigid Insulation	Varies	-	R-10 to R-15 (1.76 RSI to 2.64 RSI)	1.8 (28)	0.29 (1220)
6	Concrete Wall/ Projected Floor Slab	8" (203)	12.5 (1.8)	-	140 (2250)	0.20 (850)
7	Opening Insulation	Varies	-	R-5 to R-10 (0.88 RSI to 1.76 RSI)	27.8 (445)	0.45 (1880)
8	Shim Insulation	Optional	0.24 (0.034)	-	1.8 (28)	0.29 (1220)
9	Wood Sill	1 1/4" (30)	0.69 (0.1)	-	27.8 (445)	0.45 (1880)
10	5' (1.5m) x 6' (1.8m) Aluminum window: double glazed & thermally broken ² , IGU U _{IGU} = 0.32 BTU/hr.ft ² ·°F (1.82 W/m ² K)					
11	Aluminum Flashing	14 Gauge	1109 (160)	-	171 (2739)	0.21 (900)
12	Exterior Film ¹	-	-	R-0.2 (0.03 RSI)	-	-

¹ Value selected from table 1, p. 26.1 of 2009 ASHRAE Handbook – Fundamentals depending on surface orientation

² The thermal conductivity of air spaces within framing was found using ISO 100077-2



Detail 7.3.11

Interior Insulated Concrete Mass Wall with 1 5/8" x 1 5/8" Steel Studs (16" o.c.) Supporting Interior Finish – Window & Projected Slab Intersection – Plywood Liner and Glazing Aligned with Wall Insulation

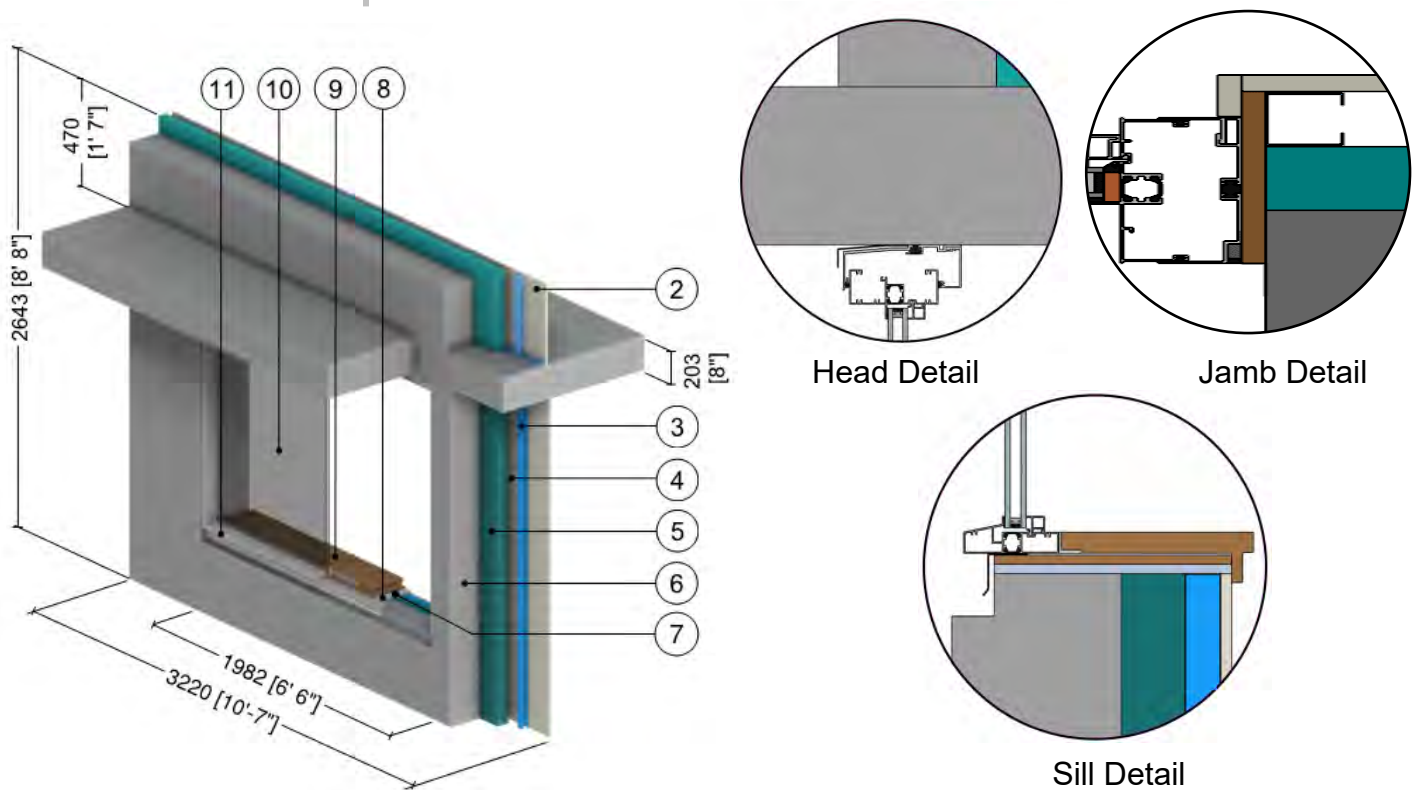

ID	Component	Thickness Inches (mm)	Conductivity Btu-in / ft ² ·hr·°F (W/m K)	Nominal Resistance hr·ft ² ·°F/Btu (m ² K/W)	Density lb/ft ³ (kg/m ³)	Specific Heat Btu/lb·°F (J/kg K)
1	Interior Film ¹	-	-	R-0.6 to R-1.1 (0.11 RSI to 0.20 RSI)	-	-
2	Gypsum Board	1/2" (13)	1.1 (0.16)	R-0.5 (0.08 RSI)	50 (800)	0.26 (1090)
3	1 5/8" x 1 5/8" Steel Studs with Top and Bottom Tracks	18 Gauge	430 (62)	-	489 (7830)	0.12 (500)
4	Air in Stud Cavity	1 5/8" (92)	-	R-0.9 (RSI-0.16)	0.075 (1.2)	0.24 (1000)
5	Continuous Rigid Insulation	Varies	-	R-10 to R-15 (1.76 RSI to 2.64 RSI)	1.8 (28)	0.29 (1220)
6	Concrete Wall/ Projected Floor Slab	8" (203)	12.5 (1.8)	-	140 (2250)	0.20 (850)
7	Plywood Liner	1/2" (13)	0.69 (0.1)	-	27.8 (445)	0.45 (1880)
8	Shim Insulation	Optional	0.24 (0.034)	-	1.8 (28)	0.29 (1220)
9	Wood Sill	1 1/4" (30)	0.69 (0.1)	-	27.8 (445)	0.45 (1880)
10	5' (1.5m) x 6' (1.8m) Aluminum window: double glazed & thermally broken ² , IGU U _{IGU} = 0.32 BTU/hr.ft ² ·°F (1.82 W/m ² K)					
11	Aluminum Flashing	14 Gauge	1109 (160)	-	171 (2739)	0.21 (900)
12	Exterior Film ¹	-	-	R-0.2 (0.03 RSI)	-	-

¹ Value selected from table 1, p. 26.1 of 2009 ASHRAE Handbook – Fundamentals depending on surface orientation

Detail 7.3.12

Exterior Insulated Concrete Mass Wall with 1 5/8" x 1 5/8" Steel Stud (16" o.c.) and Thermally Isolated Vertical Brackets and Rail System (24" o.c.) Supporting Metal Cladding – Triple Glazed Aluminum Window & Intermediate Floor Intersection with Window Thermal Break Positioned in Concrete Opening

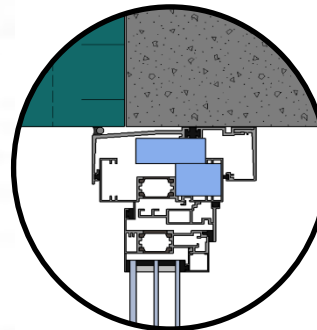
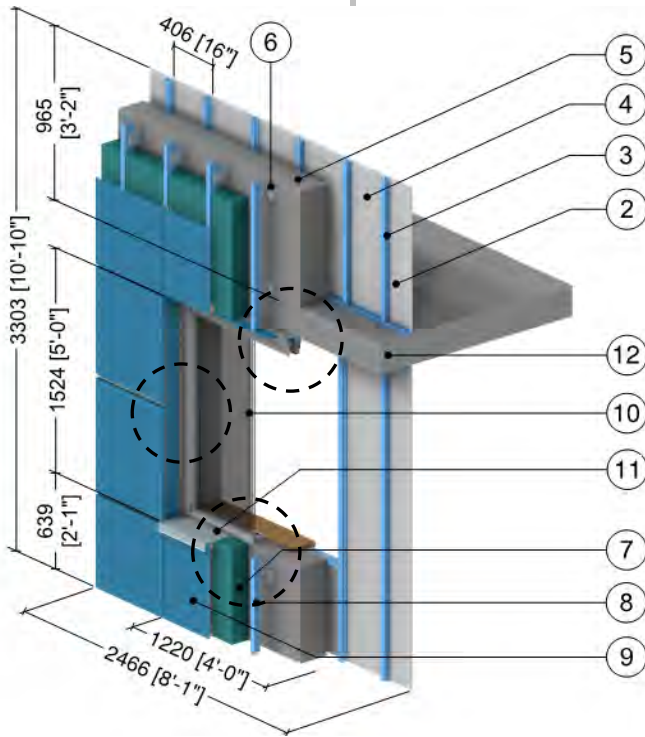

Head Detail

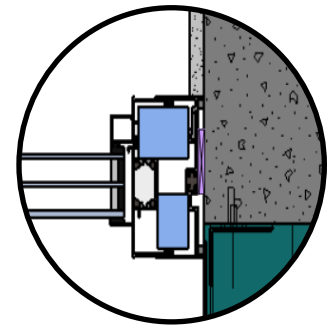

Jamb Detail

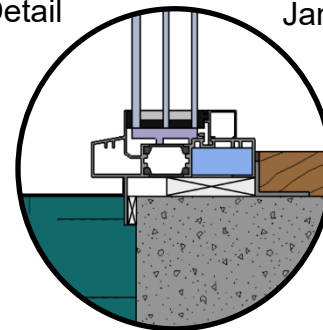

Sill Detail

ID	Component	Thickness Inches (mm)	Conductivity Btu-in / ft ² ·hr·°F (W/m K)	Nominal Resistance hr·ft ² ·°F/Btu (m ² K/W)	Density lb/ft ³ (kg/m ³)	Specific Heat Btu/lb·°F (J/kg K)
1	Interior Film ¹	-	-	R-0.6 to R-1.1 (0.11 RSI to 0.20 RSI)	-	-
2	Gypsum Board	1/2" (13)	1.1 (0.16)	R-0.5 (0.08 RSI)	50 (800)	0.26 (1090)
3	1 5/8" x 1 5/8" Steel Studs (16" o.c.) with Top and Bottom Tracks	20 Gauge	430 (62)	-	489 (7830)	0.12 (500)
4	Air in Stud Cavity	1 5/8" (41)	-	R-0.9 (0.16 RSI)	0.075 (1.2)	0.24 (1000)
5	Concrete Wall	8" (203)	12.5 (1.8)	-	140 (2250)	0.20 (850)
6	Thermally Isolated Aluminum Bracket	0.09" (2.2)	1109 (160)	-	171 (2739)	0.21 (900)
7	Exterior Insulation	Varies	-	R-10 to R-25 (1.76 RSI to 4.40 RSI)	1.8 (28)	0.29 (1220)
8	Vertical Aluminum L-girt	0.09" (2.2)	1109 (160)	-	171 (2739)	0.21 (900)
9	Generic Cladding with 1/2" (13mm) vented air space is incorporated into exterior heat transfer coefficient					
10	5' (1.5m) x 4' (1.2m) Aluminum window: triple glazed & thermally broken ² , IGU U _{IGU} = 0.14 BTU/hr.ft ² ·°F (0.81 W/m ² K)					
11	Aluminum Flashing	14 Gauge	1109 (160)	-	171 (2739)	0.21 (900)
12	Concrete Floor Slab	8" (203)	12.5 (1.8)	-	140 (2250)	0.20 (850)
13	Exterior Film ¹	-	-	R-0.2 (0.03 RSI)	-	-

¹ Value selected from table 1, p. 26.1 of 2009 ASHRAE Handbook – Fundamentals depending on surface orientation

² The thermal conductivity of air spaces within framing was found using ISO 100077-2



Detail 7.3.13

Exterior Insulated Concrete Mass Wall with 1 5/8" x 1 5/8" Steel Stud (16" o.c.) and Thermally Isolated Vertical Brackets and Rail System (24" o.c.) Supporting Metal Cladding – Triple Glazed Aluminum Curtain Wall & Intermediate Floor Intersection with Window Thermal Break Positioned in the Exterior Insulation

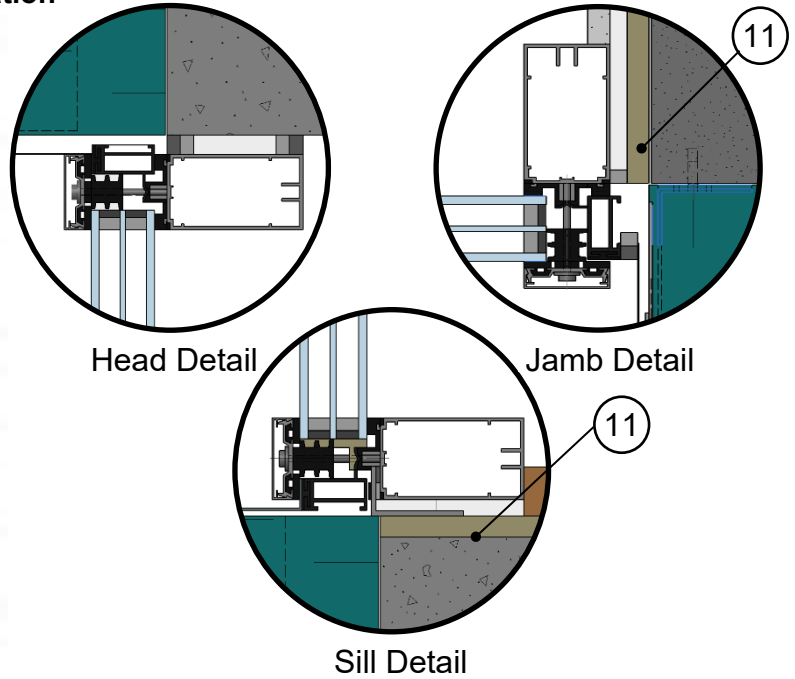
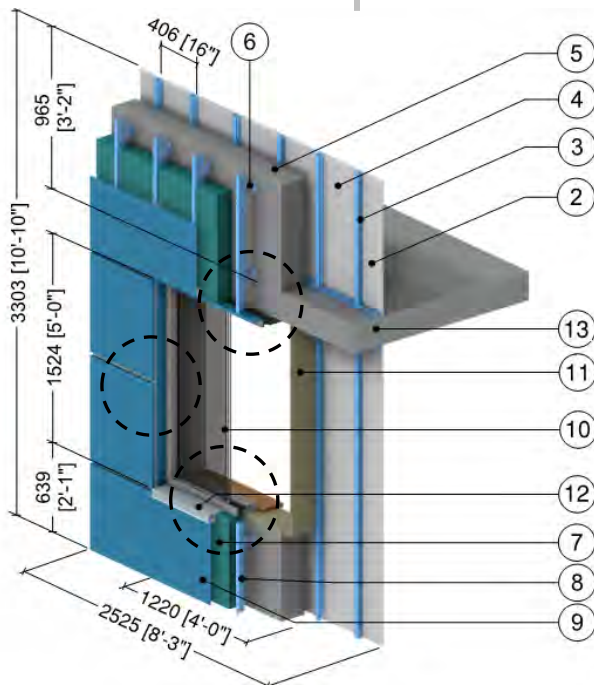

ID	Component	Thickness Inches (mm)	Conductivity Btu-in / ft ² -hr-°F (W/m K)	Nominal Resistance hr-ft ² -°F/Btu (m ² K/W)	Density lb/ft ³ (kg/m ³)	Specific Heat Btu/lb-°F (J/kg K)
1	Interior Film ¹	-	-	R-0.6 to R-1.1 (0.11 RSI to 0.20 RSI)	-	-
2	Gypsum Board	1/2" (13)	1.1 (0.16)	R-0.5 (0.08 RSI)	50 (800)	0.26 (1090)
3	1 5/8" x 1 5/8" Steel Studs (16" o.c.) with Top and Bottom Tracks	18 Gauge	430 (62)	-	489 (7830)	0.12 (500)
4	Air in Stud Cavity	1 5/8" (41)	-	R-0.9 (0.16 RSI)	0.075 (1.2)	0.24 (1000)
5	Concrete Wall	8" (203)	12.5 (1.8)	-	140 (2250)	0.20 (850)
6	Thermally Isolated Aluminum Bracket	0.09" (2.2)	1109 (160)	-	171 (2739)	0.21 (900)
7	Exterior Insulation	Varies	-	R-10 to R-25 (1.76 RSI to 4.40 RSI)	1.8 (28)	0.29 (1220)
8	Vertical Aluminum L-girt	0.09" (2.2)	1109 (160)	-	171 (2739)	0.21 (900)
9	Generic Cladding with 1/2" (13mm) vented air space is incorporated into exterior heat transfer coefficient					
10	5' (1.5m) x 4' (1.2m) Aluminum curtain wall (Passive House certified): triple glazed & thermally broken ² , IGU U _{IGU} = 0.14 BTU/hr.ft ² .°F (0.81 W/m ² K)					
11	Wood Liner	1/2" (13)	0.69 (0.10)	-	31 (500)	0.45 (1880)
12	Aluminum Flashing	14 Gauge	1109 (160)	-	171 (2739)	0.21 (900)
13	Concrete Slab	8" (203)	12.5 (1.8)	-	140 (2250)	0.20 (850)
14	Exterior Film ¹	-	-	R-0.2 (0.03 RSI)	-	-

¹ Value selected from table 1, p. 26.1 of 2009 ASHRAE Handbook – Fundamentals depending on surface orientation

² The thermal conductivity of air spaces within framing was found using ISO 100077-2



Detail 7.3.14

Owens Corning Exterior Insulated Concrete Block Wall Assembly with Heckmann Pos-I-Tie Vener Anchoring System Supporting Brick Veneer with Insulation Interrupted at Window Perimeter – Double Glazed Aluminum Window and Intermediate Floor Intersection

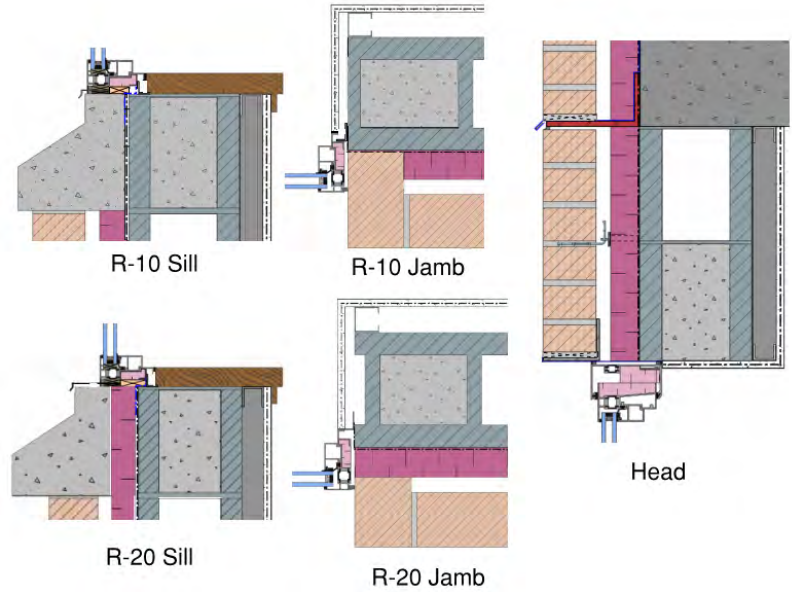
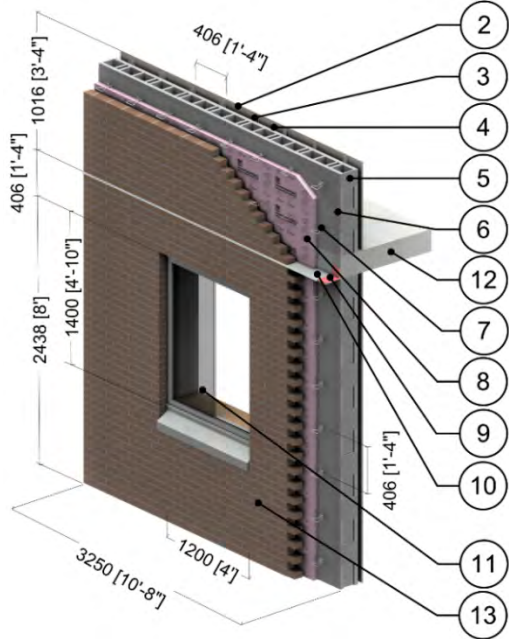

ID	Component	Thickness Inches (mm)	Conductivity Btu-in / ft ² -hr-°F (W/m K)	Nominal Resistance hr-ft ² -°F/Btu (m ² K/W)	Density lb/ft ³ (kg/m ³)	Specific Heat Btu/lb-°F (J/kg K)
1	Interior Films ¹	-	-	R-0.6 to R-1.1 (0.11 to 0.20 RSI)	-	-
2	Gypsum Board	1/2" (13)	1.1 (0.16)	R-0.5 (0.08 RSI)	50 (800)	0.26 (1090)
3	1 5/8" x 1 5/8" Steel Studs (16" o.c.) with Top and Bottom Tracks	18 Gauge	430 (62)	-	489 (7830)	0.12 (500)
4	Air in Stud Cavity	1 5/8" (41)	-	R-0.9 (0.16 RSI)	0.075 (1.2)	0.24 (1000)
5	Standard Concrete Block	7 5/8" (190)	3.5 (0.5)	-	119 (1900)	0.19 (800)
6	Cement Mortar	-	3.5 (0.5)	-	119 (1900)	0.12 (500)
7	Heckmann Pos-I-Tie Masonry Tie @ 16" (406) o.c.	varies	-	-	-	-
8	Foamular CodeBord/C-200 Extruded Polystyrene (XPS) Rigid Insulation Type 3	varies	0.20 (0.029)	R-10 to R-20 (1.76 to 3.52 RSI)	1.8 (28)	0.29 (1220)
9	Steel Shelf Angle	3/8" (10)	347 (50)	-	489 (7830)	0.12 (500)
10	Steel Lintel	1/4" (6)	347 (50)	-	489 (7830)	0.12 (500)
11	4'8 (1.4m) x 4' (1.2m) Aluminum window: thermally broken, double glazed IGU ² U _{IGU} = 0.321 BTU/hr.ft ² .°F (1.82 W/m ² K)					
12	Concrete Slab	8" (203)	12 (1.8)	-	140 (2250)	0.20 (850)
13	Brick Veneer	3 5/8" (92)	5.4 (0.78)	-	120 (1920)	0.19 (720)
14	Exterior Film ¹	-	-	R-0.2 (0.03 RSI)	-	-

¹ Value selected from table 1, p. 26.1 of 2009 ASHRAE Handbook – Fundamentals depending on surface orientation

² The thermal conductivity of air spaces was found using ISO 100077-2

Detail 7.3.15

Owens Corning Exterior Insulated Concrete Block Wall Assembly with Heckmann Pos-I-Tie Vener Anchoring System Supporting Brick Veneer with Reduced Insulation at Jamb – Triple Glazed Aluminum High Performance Window and Intermediate Floor Intersection

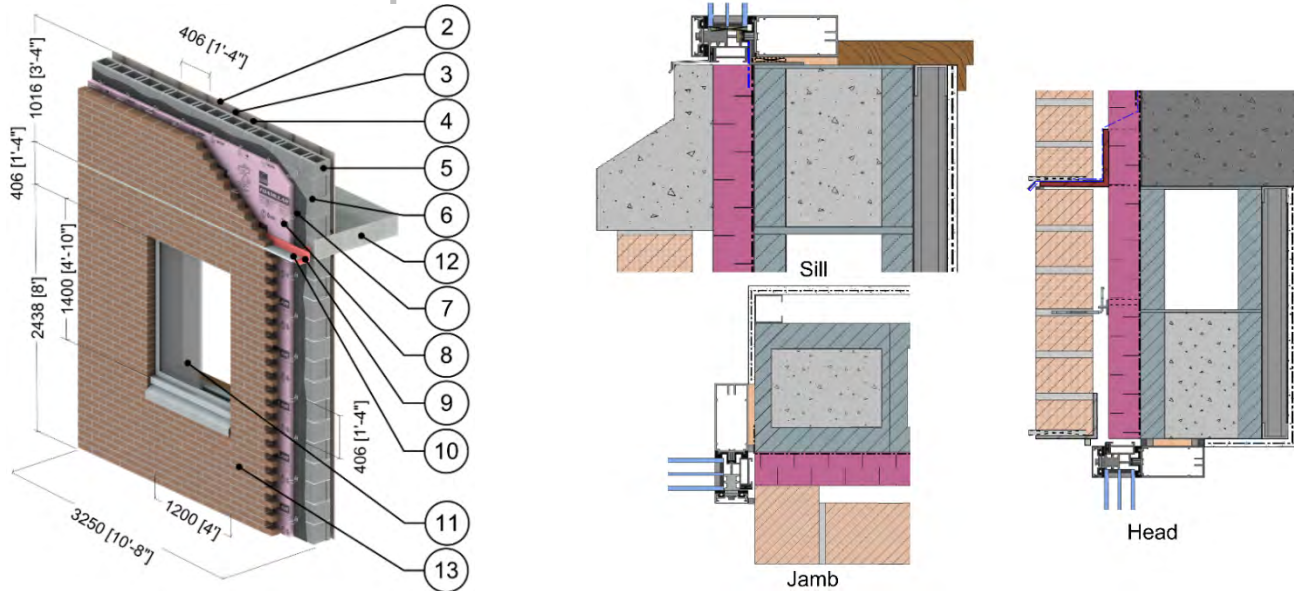

ID	Component	Thickness Inches (mm)	Conductivity Btu-in / ft ² -hr-°F (W/m K)	Nominal Resistance hr-ft ² -°F/Btu (m ² K/W)	Density lb/ft ³ (kg/m ³)	Specific Heat Btu/lb-°F (J/kg K)
1	Interior Films ¹	-	-	R-0.6 to R-1.1 (0.11 to 0.20 RSI)	-	-
2	Gypsum Board	1/2" (13)	1.1 (0.16)	R-0.5 (0.08 RSI)	50 (800)	0.26 (1090)
3	1 5/8" x 1 5/8" Steel Studs (16" o.c.) with Top and Bottom Tracks	18 Gauge	430 (62)	-	489 (7830)	0.12 (500)
4	Air in Stud Cavity	1 5/8" (41)	-	R-0.9 (0.16 RSI)	0.075 (1.2)	0.24 (1000)
5	Standard Concrete Block	7 5/8" (190)	3.5 (0.5)	-	119 (1900)	0.19 (800)
6	Cement Mortar	-	3.5 (0.5)	-	119 (1900)	0.12 (500)
7	Heckmann Pos-I-Tie Masonry Tie @ 16" (406) o.c.	varies	-	-	-	-
8	Foamular CodeBord/C-200 Extruded Polystyrene (XPS) Rigid Insulation Type 3	varies	0.20 (0.029)	R-10 to R-20 (1.76 to 3.52 RSI)	1.8 (28)	0.29 (1220)
9	Stainless Steel Shelf Angle	3/8" (10)	118 (17)	-	503 (8060)	0.12 (500)
10	Steel Lintel	1/4" (6)	347 (50)	-	489 (7830)	0.12 (500)
11	4'8 (1.5m) x 4' (1.2m) Aluminum window: thermally broken, triple glazed IGU ² U _{IGU} = 0.22 BTU/hr.ft ² .°F (1.25 W/m ² K)					
12	Concrete Slab	8" (203)	12 (1.8)	-	140 (2250)	0.20 (850)
13	Brick Veneer	3 5/8" (92)	5.4 (0.78)	-	120 (1920)	0.19 (720)
14	Spray Foam Insulation	3/8" (10)	0.17 (0.024)	-	2.8 (39)	0.35 (1470)
15	Exterior Film ¹	-	-	R-0.2 (0.03 RSI)	-	-

¹ Value selected from table 1, p. 26.1 of 2009 ASHRAE Handbook – Fundamentals depending on surface orientation

² The thermal conductivity of air spaces was found using ISO 100077-2

Detail 7.3.16

Interior Insulated Multi-Wythe Brick Masonry Wall with 1 5/8" x 1 5/8" Steel Studs (16" o.c.) Supporting Interior Finish – Wood Window Intersection with Un-Insulated Window Perimeter

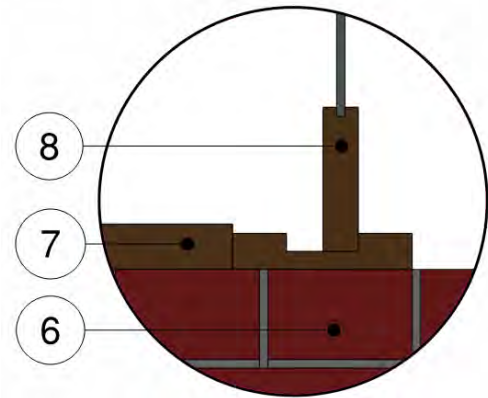
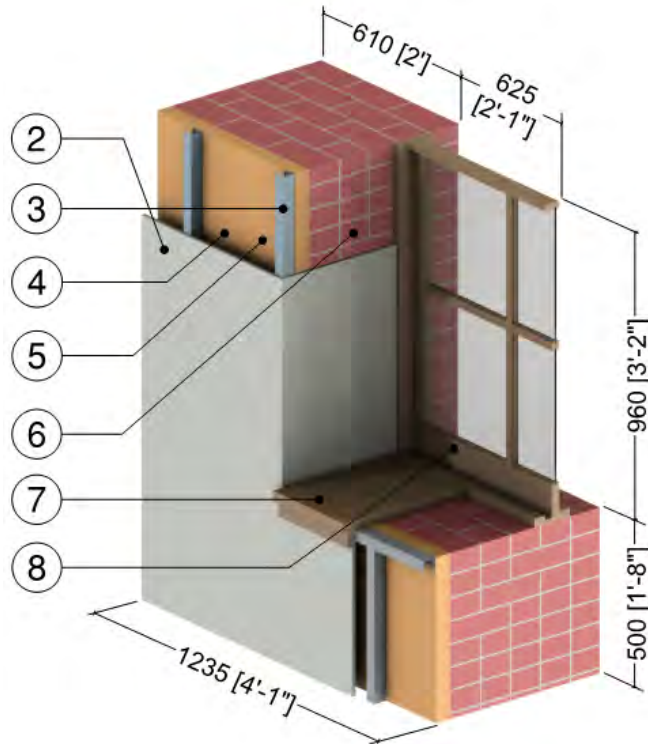

Single Glazed Wood Window on Brick Detail

ID	Component	Thickness Inches (mm)	Conductivity Btu-in / ft ² ·hr·°F (W/m K)	Nominal Resistance hr·ft ² ·°F/Btu (m ² K/W)	Density lb/ft ³ (kg/m ³)	Specific Heat Btu/lb·°F (J/kg K)
1	Interior Films ¹	-	-	R-0.6 to R-0.9 (0.11 RSI to 0.16 RSI)	-	-
2	Gypsum Board	1/2" (13)	1.1 (0.16)	R-0.5 (0.08 RSI)	50 (800)	0.26 (1090)
3	1 5/8" x 1 5/8" Steel Studs with Top and Bottom Tracks	18 Gauge	430 (62)	-	489 (7830)	0.12 (500)
4	Air in Stud Cavity	1 5/8" (92)	-	R-0.9 (0.16 RSI)	0.075 (1.2)	0.24 (1000)
5	Spray Foam Insulation	Varies	0.17 (0.024)	R-6 to R-12 (1.06 RSI to 2.11 RSI)	2.4 (39)	0.35 (1470)
6	5-Wythe Brick Wall	21" (540)	6.24 (0.9)	R-3.4 (0.60 RSI)	120 (1920)	0.19 (720)
7	Wood Sill	1 1/4" (32)	0.69 (0.10)	-	27.8 (445)	0.45 (1880)
8	6' (1.9 m) x 4' (1.2 m) Wood window: single glazed vision U _{IGU} = 1.04 Btu/hr ft ² °F (5.92 W/m ² K)					
9	Exterior Film ¹	-	-	R-0.2 (0.03 RSI)	-	-

¹ Value selected from table 1, p. 26.1 of 2009 ASHRAE Handbook – Fundamentals depending on surface orientation

Detail 7.3.17

Interior Insulated Multi-Wythe Brick Masonry Wall with 1 5/8" x 1 5/8" Steel Studs (16" o.c.) Supporting Interior Finish – Aluminum Window Intersection with Un-Insulated Window Perimeter

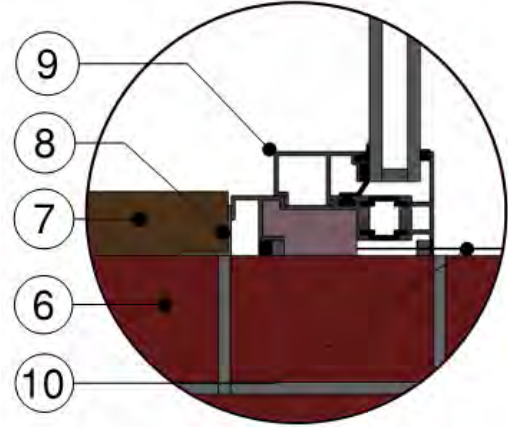
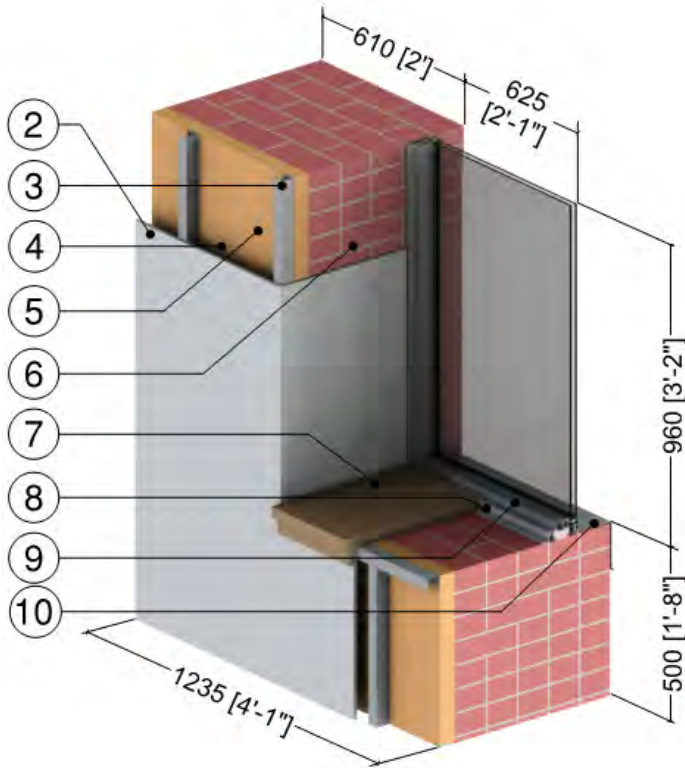

Double Glazed Aluminum Window on Brick Detail

ID	Component	Thickness Inches (mm)	Conductivity Btu-in / ft ² -hr-°F (W/m K)	Nominal Resistance hr-ft ² -°F/Btu (m ² K/W)	Density lb/ft ³ (kg/m ³)	Specific Heat Btu/lb-°F (J/kg K)
1	Interior Films ¹	-	-	R-0.6 to R-0.9 (0.11 RSI to 0.16 RSI)	-	-
2	Gypsum Board	1/2" (13)	1.1 (0.16)	R-0.5 (0.08 RSI)	50 (800)	0.26 (1090)
3	1 5/8" x 1 5/8" Steel Studs with Top and Bottom Tracks	18 Gauge	430 (62)	-	489 (7830)	0.12 (500)
4	Air in Stud Cavity	1 5/8" (92)	-	R-0.9 (0.16 RSI)	0.075 (1.2)	0.24 (1000)
5	Spray Foam Insulation	Varies	0.17 (0.024)	R-6 to R-12 (1.06 RSI to 2.11 RSI)	2.4 (39)	0.35 (1470)
6	5-Wythe Brick Wall	21" (540)	6.24 (0.9)	R-3.4 (0.60 RSI)	120 (1920)	0.19 (720)
7	Wood Sill	1 1/4" (32)	0.69 (0.10)	-	27.8 (445)	0.45 (1880)
8	Sill Angle	18 Gauge	430 (62)	-	489 (7830)	0.12 (500)
9	6' (1.9 m) x 4' (1.2 m) Aluminum window: double glazed IGU U _{IGU} = 0.321 Btu/hr ft ² °F (1.82 W/m ² K)					
10	Flashing	18 Gauge	430 (62)	-	489 (7830)	0.12 (500)
11	Exterior Film ¹	-	-	R-0.2 (0.03 RSI)	-	-

¹ Value selected from table 1, p. 26.1 of 2009 ASHRAE Handbook – Fundamentals depending on surface orientation

Detail 7.3.18

Interior Insulated Multi-Wythe Brick Masonry Wall with 1 5/8" x 1 5/8" Steel Studs (16" o.c.) Supporting Interior Finish – Aluminum Window Intersection with Insulation at Window Perimeter

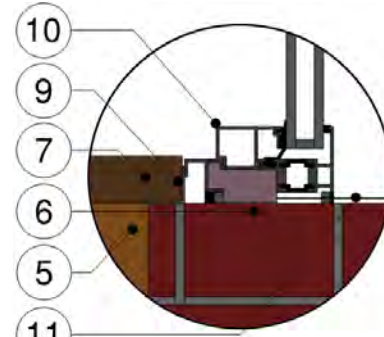
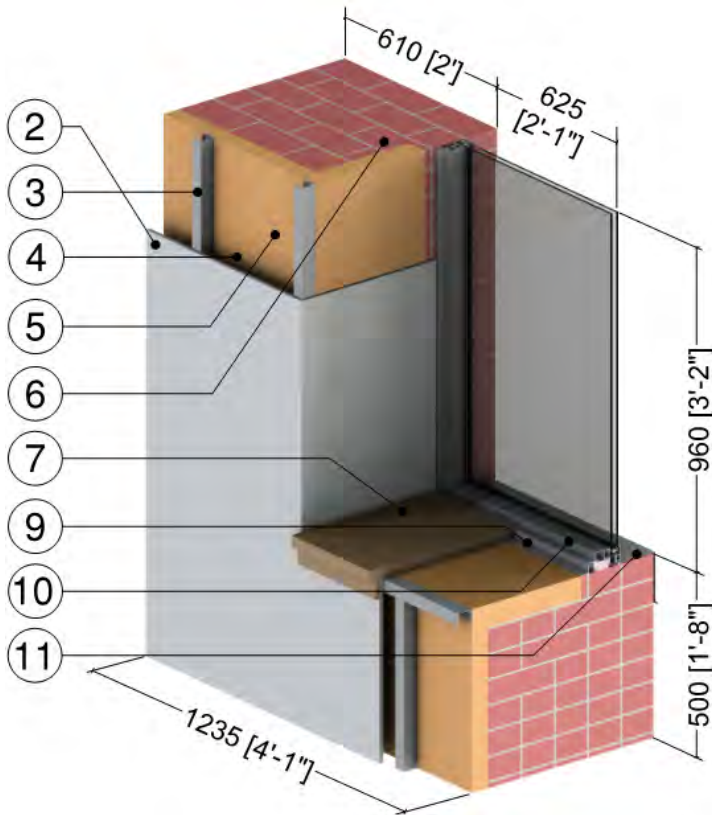

Case A: Window on Brick with Insulation at Window Perimeter

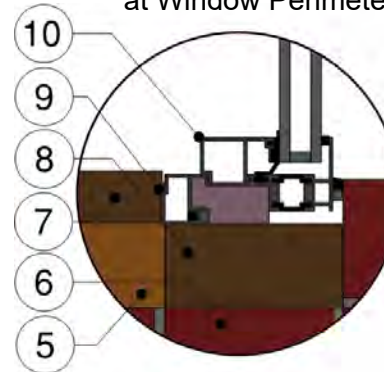

Case B: Window on Wood Block with Insulation at Window Perimeter

ID	Component	Thickness Inches (mm)	Conductivity Btu·in / ft ² ·hr·°F (W/m K)	Nominal Resistance hr·ft ² ·°F/Btu (m ² K/W)	Density lb/ft ³ (kg/m ³)	Specific Heat Btu/lb·°F (J/kg K)
1	Interior Films ¹	-	-	R-0.6 to R-0.9 (0.11 RSI to 0.16 RSI)	-	-
2	Gypsum Board	1/2" (13)	1.1 (0.16)	R-0.5 (0.08 RSI)	50 (800)	0.26 (1090)
3	1 5/8" x 1 5/8" Steel Studs with Top and Bottom Tracks	18 Gauge	430 (62)	-	489 (7830)	0.12 (500)
4	Air in Stud Cavity	1 5/8" (92)	-	R-0.9 (0.16 RSI)	0.075 (1.2)	0.24 (1000)
5	Spray Foam Insulation	2" (51)	0.17 (0.024)	R-12 (2.11 RSI)	2.4 (39)	0.35 (1470)
6	5-Wythe Brick Wall	21" (540)	6.24 (0.9)	R-3.4 (0.60 RSI)	120 (1920)	0.19 (720)
7	Wood Sill	1 1/4" (32)	0.69 (0.10)	-	27.8 (445)	0.45 (1880)
8	Wood Block	2" (51)	0.69 (0.10)	-	27.8 (445)	0.45 (1880)
9	Sill Angle	18 Gauge	430 (62)	-	489 (7830)	0.12 (500)
10	6' (1.9 m) x 4' (1.2 m) Aluminum window: double glazed IGU U _{IGU} = 0.321 Btu/hr ft ² °F (1.82 W/m ² K)					
11	Flashing	18 Gauge	430 (62)	-	489 (7830)	0.12 (500)
12	Exterior Film ¹	-	-	R-0.2 (0.03 RSI)	-	-

¹ Value selected from table 1, p. 26.1 of 2009 ASHRAE Handbook – Fundamentals depending on surface orientation



Detail 7.3.19

Interior Insulated Multi-Wythe Brick Masonry Wall with 1 5/8" x 1 5/8" Steel Studs (16" o.c.) Supporting Interior Finish – Aluminum Window Intersection with Aerogel Blanket at Window Perimeter

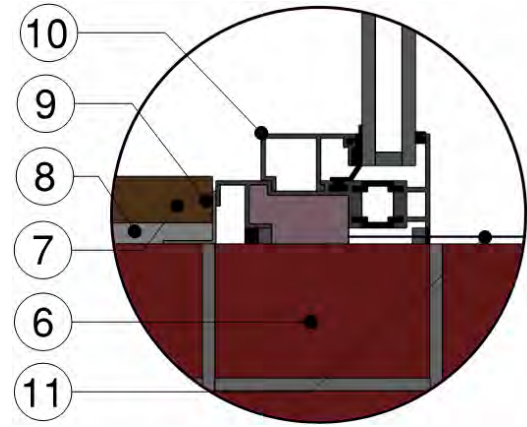
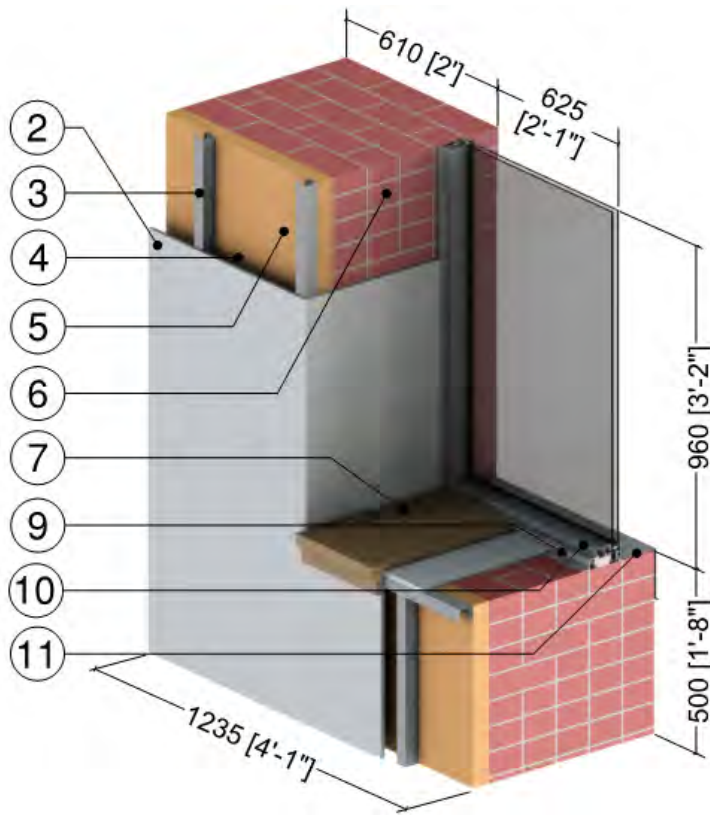

Aerogel Blanket at Window Perimeter

ID	Component	Thickness Inches (mm)	Conductivity Btu-in / ft ² -hr-°F (W/m K)	Nominal Resistance hr-ft ² -°F/Btu (m ² K/W)	Density lb/ft ³ (kg/m ³)	Specific Heat Btu/lb-°F (J/kg K)
1	Interior Films ¹	-	-	R-0.6 to R-0.9 (0.11 RSI to 0.16 RSI)	-	-
2	Gypsum Board	1/2" (13)	1.1 (0.16)	R-0.5 (0.08 RSI)	50 (800)	0.26 (1090)
3	1 5/8" x 1 5/8" Steel Studs with Top and Bottom Tracks	18 Gauge	430 (62)	-	489 (7830)	0.12 (500)
4	Air in Stud Cavity	1 5/8" (92)	-	R-0.9 (0.16 RSI)	0.075 (1.2)	0.24 (1000)
5	Spray Foam Insulation	2" (51)	0.17 (0.024)	R-12 (2.11 RSI)	2.4 (39)	0.35 (1470)
6	5-Wythe Brick Wall	21" (540)	6.24 (0.9)	R-3.4 (0.60 RSI)	120 (1920)	0.19 (720)
7	Wood Sill	1 1/4" (32)	0.69 (0.10)	-	27.8 (445)	0.45 (1880)
8	Aerogel Blanket	0.4" (10)	0.1 (0.015)	-	-	-
9	Sill Angle	18 Gauge	430 (62)	-	489 (7830)	0.12 (500)
10	6' (1.9 m) x 4' (1.2 m) Aluminum window: double glazed IGU U _{IGU} = 0.321 Btu/hr ft ² °F (1.82 W/m ² K)					
11	Flashing	18 Gauge	430 (62)	-	489 (7830)	0.12 (500)
12	Exterior Film ¹	-	-	R-0.2 (0.03 RSI)	-	-

¹ Value selected from table 1, p. 26.1 of 2009 ASHRAE Handbook – Fundamentals depending on surface orientation



Detail 7.3.20

Precast Sandwich Panel Wall Assembly with PVC at Panel Perimeter, Steel Connectors at 24" (o.c.), and 3 5/8" Steel Stud (16" o.c.) – Window Intersection

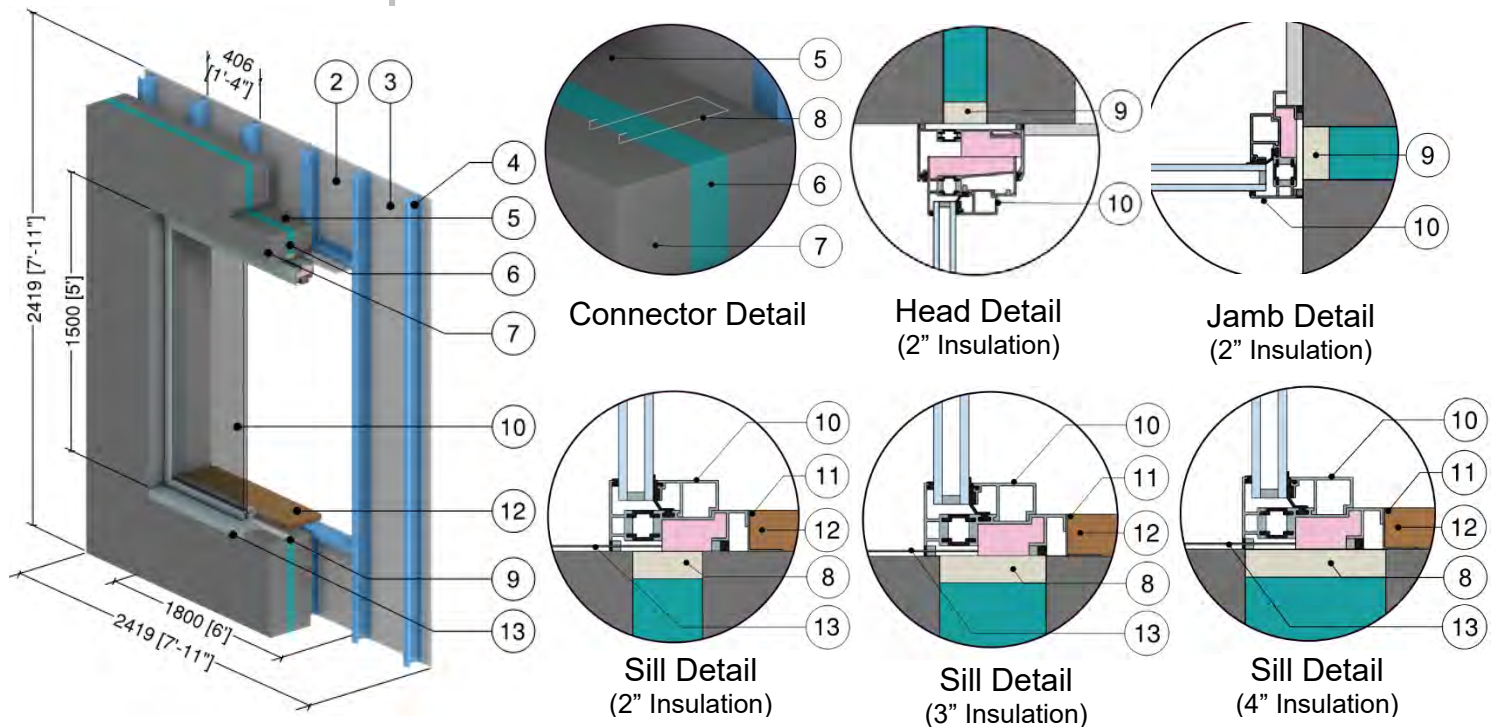

ID	Component	Thickness Inches (mm)	Conductivity Btu-in / ft ² -hr-°F (W/m K)	Nominal Resistance hr-ft ² -°F/Btu (m ² K/W)	Density lb/ft ³ (kg/m ³)	Specific Heat Btu/lb-°F (J/kg K)
1	Interior Film ¹	-	-	R-0.7 to R-1.1 (0.12 RSI to 0.20 RSI)	-	-
2	Gypsum Board	1/2" (13)	1.1 (0.16)	R-0.5 (0.08 RSI)	50 (800)	0.26 (1090)
3	Air in Stud Cavity	4.7" (120)	-	R-0.9 (0.16 RSI)	0.075 (1.2)	0.24 (1000)
4	3 5/8" Steel Studs with Metal Tracks	18 Gauge	430 (62)	-	489 (7830)	0.12 (500)
5	Precast Sandwich Panel, Interior Concrete	4" (102)	12.5 (1.8)	-	140 (2250)	0.20 (850)
6	Precast Sandwich Panel, Insulation	Varies	-	R-10 to R-20 (1.76 RSI to 3.52 RSI)	1.8 (28)	0.29 (1220)
7	Precast Sandwich Panel, Exterior Concrete	4" (102)	12.5 (1.8)	-	140 (2250)	0.20 (850)
8	Precast Sandwich Panel, Steel Connectors @ 24" (610) o.c.	16 Gauge	430 (62)	-	489 (7830)	0.12 (500)
9	PVC Foam Perimeter Thermal Break	1" (25)	0.42 (0.06)	-	14 (223)	0.45 (1884)
10	1.5m (H) x 1.2m (W) Aluminum window: double glazed & thermally broken ²					
11	Sill Angle	18 Gauge	430 (62)	-	489 (7830)	0.12 (500)
12	Wood Sill	1 1/4" (30)	0.69 (0.10)	-	27.8 (445)	0.45 (1880)
13	Flashing	14 Gauge	430 (62)	-	489 (7830)	0.12 (500)
14	Exterior Film ¹	-	-	R-0.2 (0.03 RSI)	-	-

¹ Value selected from table 1, p. 26.1 of 2009 ASHRAE Handbook – Fundamentals depending on surface orientation

² The thermal conductivity of air spaces within framing was found using ISO 100077-2



Detail 7.3.21

Precast Sandwich Panel Wall Assembly with Wood at Panel Perimeter, Steel Connectors at 24" (o.c.), and 3 5/8" Steel Stud (16" o.c.) – Window Intersection

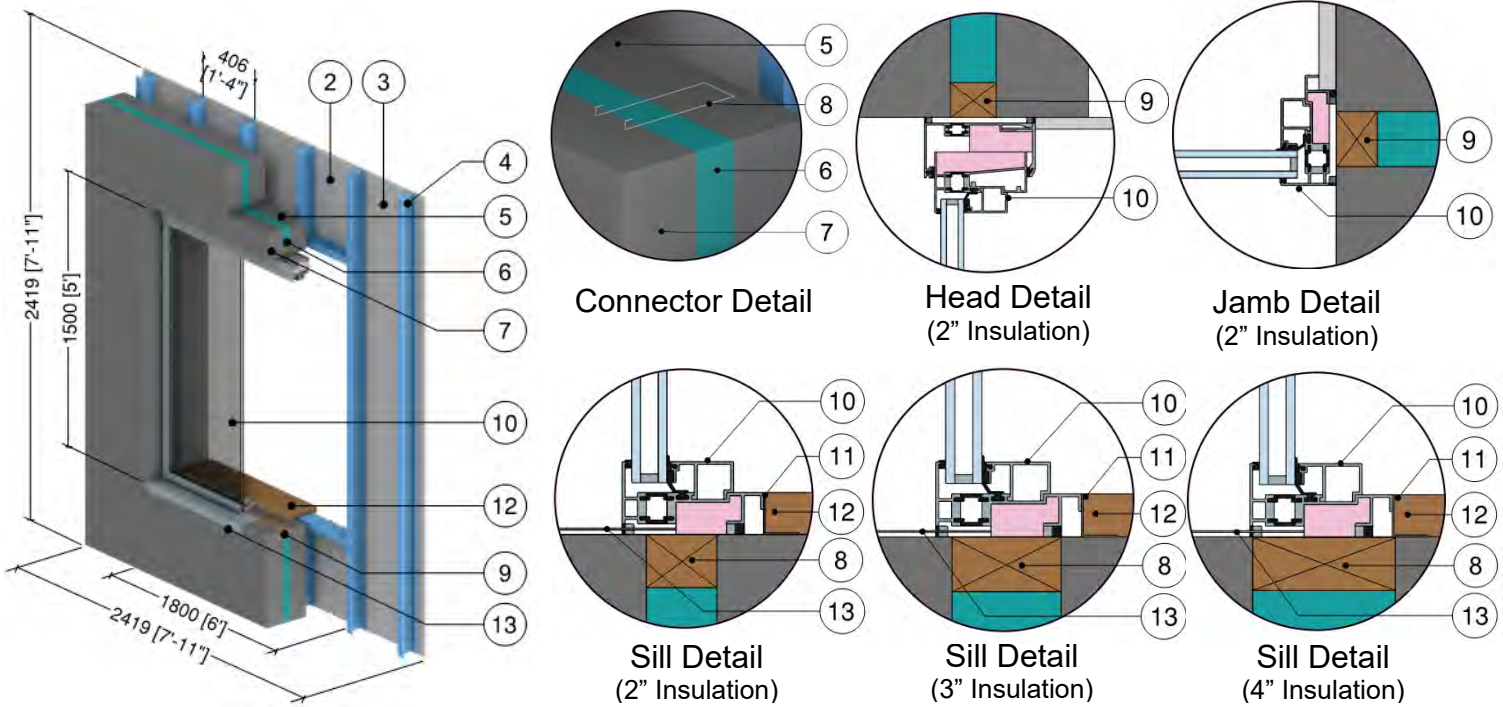

ID	Component	Thickness Inches (mm)	Conductivity Btu-in / ft ² ·hr·°F (W/m K)	Nominal Resistance hr·ft ² ·°F/Btu (m ² K/W)	Density lb/ft ³ (kg/m ³)	Specific Heat Btu/lb·°F (J/kg K)
1	Interior Film ¹	-	-	R-0.7 to R-1.1 (0.12 RSI to 0.20 RSI)	-	-
2	Gypsum Board	1/2" (13)	1.1 (0.16)	R-0.5 (0.08 RSI)	50 (800)	0.26 (1090)
3	Air in Stud Cavity	4.7" (120)	-	R-0.9 (0.16 RSI)	0.075 (1.2)	0.24 (1000)
4	3 5/8" Steel Studs with Metal Tracks	18 Gauge	430 (62)	-	489 (7830)	0.12 (500)
5	Precast Sandwich Panel, Interior Concrete	4" (102)	12.5 (1.8)	-	140 (2250)	0.20 (850)
6	Precast Sandwich Panel, Insulation	Varies	-	R-10 to R-20 (1.76 RSI to 3.52 RSI)	1.8 (28)	0.29 (1220)
7	Precast Sandwich Panel, Exterior Concrete	4" (102)	12.5 (1.8)	-	140 (2250)	0.20 (850)
8	Precast Sandwich Panel, Steel Connectors @ 24" (610) o.c.	16 Gauge	430 (62)	-	489 (7830)	0.12 (500)
9	Wood Perimeter Thermal Break	1 1/2" (38)	0.69 (0.10)	-	27.8 (445)	0.45 (1880)
10	1.5m (H) x 1.2m (W) Aluminum window: double glazed & thermally broken ²					
11	Sill Angle	18 Gauge	430 (62)	-	489 (7830)	0.12 (500)
12	Wood Sill	1 1/4" (30)	0.69 (0.10)	-	27.8 (445)	0.45 (1880)
13	Flashing	14 Gauge	430 (62)	-	489 (7830)	0.12 (500)
14	Exterior Film ¹	-	-	R-0.2 (0.03 RSI)	-	-

¹ Value selected from table 1, p. 26.1 of 2009 ASHRAE Handbook – Fundamentals depending on surface orientation

² The thermal conductivity of air spaces within framing was found using ISO 100077-2



Detail 7.3.22

Precast Sandwich Panel Wall Assembly with Gypsum Board at Panel Perimeter, Steel Connectors at 24" (o.c.), and 3 5/8" Steel Stud (16" o.c.) – Window Intersection

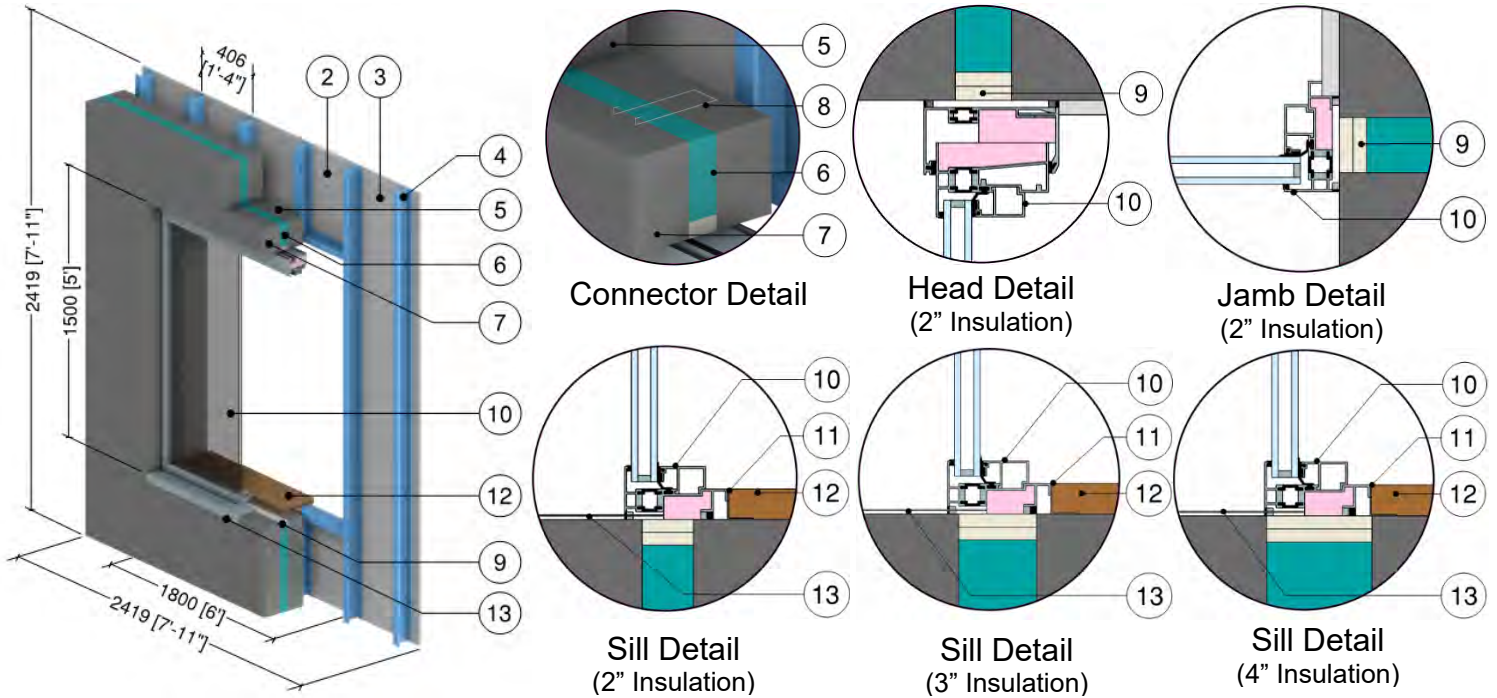

ID	Component	Thickness Inches (mm)	Conductivity Btu-in / ft ² ·hr·°F (W/m K)	Nominal Resistance hr·ft ² ·°F/Btu (m ² K/W)	Density lb/ft ³ (kg/m ³)	Specific Heat Btu/lb·°F (J/kg K)
1	Interior Film ¹	-	-	R-0.7 to R-1.1 (0.12 RSI to 0.20 RSI)	-	-
2	Gypsum Board	1/2" (13)	1.1 (0.16)	R-0.5 (0.08 RSI)	50 (800)	0.26 (1090)
3	Air in Stud Cavity	4.7" (120)	-	R-0.9 (0.16 RSI)	0.075 (1.2)	0.24 (1000)
4	3 5/8" Steel Studs with Metal Tracks	18 Gauge	430 (62)	-	489 (7830)	0.12 (500)
5	Precast Sandwich Panel, Interior Concrete	4" (102)	12.5 (1.8)	-	140 (2250)	0.20 (850)
6	Precast Sandwich Panel, Insulation	Varies	-	R-10 to R-20 (1.76 RSI to 3.52 RSI)	1.8 (28)	0.29 (1220)
7	Precast Sandwich Panel, Exterior Concrete	4" (102)	12.5 (1.8)	-	140 (2250)	0.20 (850)
8	Precast Sandwich Panel, Steel Connectors @ 24" (610) o.c.	16 Gauge	430 (62)	-	489 (7830)	0.12 (500)
9	Gypsum Perimeter Thermal Break (2 layers)	1/2" (13)	1.1 (0.16)	R-0.5 (0.08 RSI)	50 (800)	0.26 (1090)
10	1.5m (H) x 1.2m (W) Aluminum window: double glazed & thermally broken ²					
11	Sill Angle	18 Gauge	430 (62)	-	489 (7830)	0.12 (500)
12	Wood Sill	1 1/4" (30)	0.69 (0.10)	-	27.8 (445)	0.45 (1880)
13	Flashing	14 Gauge	430 (62)	-	489 (7830)	0.12 (500)
14	Exterior Film ¹	-	-	R-0.2 (0.03 RSI)	-	-

¹ Value selected from table 1, p. 26.1 of 2009 ASHRAE Handbook – Fundamentals depending on surface orientation

² The thermal conductivity of air spaces within framing was found using ISO 100077-2



Detail 7.3.23

Precast Sandwich Panel Wall Assembly, Steel Connectors at 24" (o.c.), and 3 5/8" Steel Stud (16" o.c.) – Window Intersection

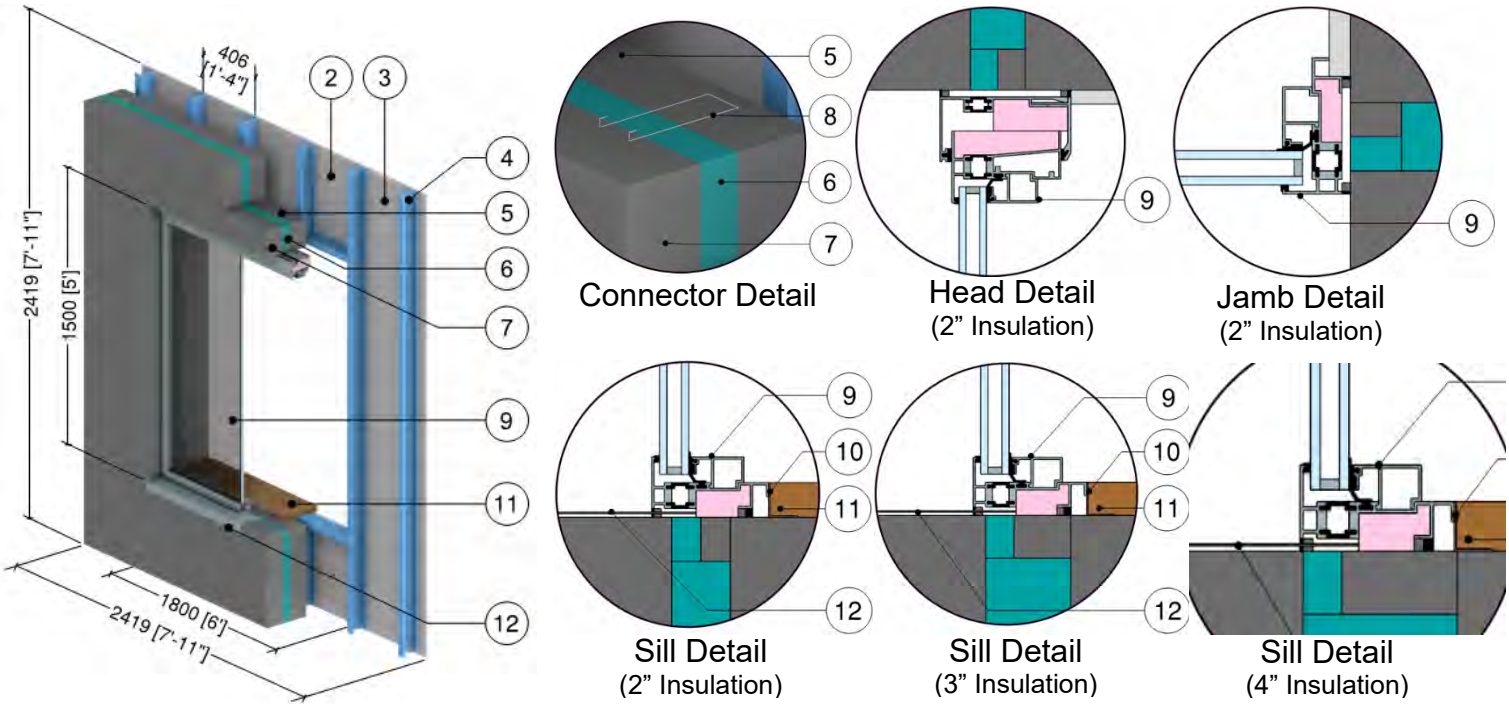

ID	Component	Thickness Inches (mm)	Conductivity Btu-in / ft ² ·hr·°F (W/m K)	Nominal Resistance hr·ft ² ·°F/Btu (m ² K/W)	Density lb/ft ³ (kg/m ³)	Specific Heat Btu/lb·°F (J/kg K)
1	Interior Film ¹	-	-	R-0.7 to R-1.1 (0.12 RSI to 0.20 RSI)	-	-
2	Gypsum Board	1/2" (13)	1.1 (0.16)	R-0.5 (0.08 RSI)	50 (800)	0.26 (1090)
3	Air in Stud Cavity	4.7" (120)	-	R-0.9 (0.16 RSI)	0.075 (1.2)	0.24 (1000)
4	3 5/8" Steel Studs with Metal Tracks	18 Gauge	430 (62)	-	489 (7830)	0.12 (500)
5	Precast Sandwich Panel, Interior Concrete	4" (102)	12.5 (1.8)	-	140 (2250)	0.20 (850)
6	Precast Sandwich Panel, Insulation	Varies	-	R-10 to R-20 (1.76 RSI to 3.52 RSI)	1.8 (28)	0.29 (1220)
7	Precast Sandwich Panel, Exterior Concrete	4" (102)	12.5 (1.8)	-	140 (2250)	0.20 (850)
8	Precast Sandwich Panel, Steel Connectors @ 24" (610) o.c.	16 Gauge	430 (62)	-	489 (7830)	0.12 (500)
9	1.5m (H) x 1.2m (W) Aluminum window: double glazed & thermally broken ²					
10	Sill Angle	18 Gauge	430 (62)	-	489 (7830)	0.12 (500)
11	Wood Sill	1 1/4" (30)	0.69 (0.10)	-	27.8 (445)	0.45 (1880)
12	Flashing	14 Gauge	430 (62)	-	489 (7830)	0.12 (500)
13	Exterior Film ¹	-	-	R-0.2 (0.03 RSI)	-	-

¹ Value selected from table 1, p. 26.1 of 2009 ASHRAE Handbook – Fundamentals depending on surface orientation

² The thermal conductivity of air spaces within framing was found using ISO 100077-2



Detail 7.4.1

Exterior Insulated Concrete Drained EIFS Wall Assembly – Conventional Curtain Wall Transition

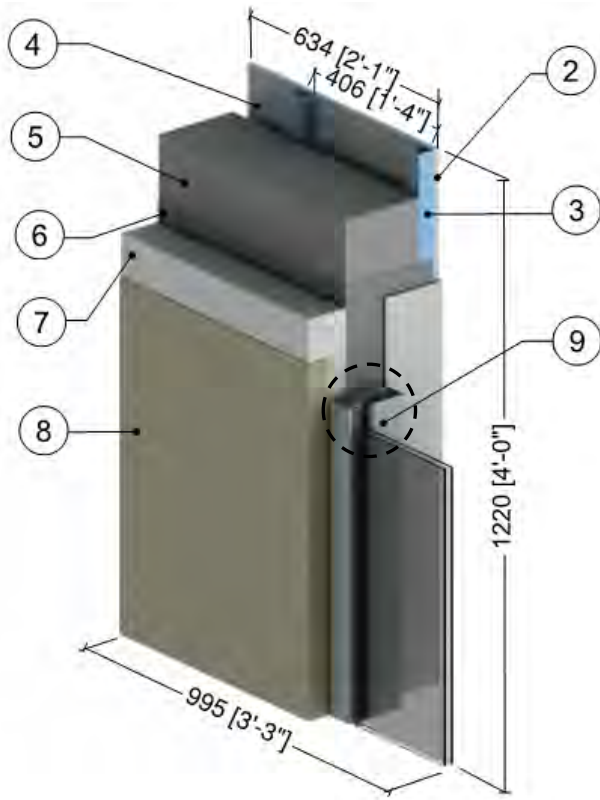

Curtain Wall Jamb Detail

ID	Component	Thickness Inches (mm)	Conductivity Btu-in / ft ² -hr-°F (W/m K)	Nominal Resistance hr-ft ² -°F/Btu (m ² K/W)	Density lb/ft ³ (kg/m ³)	Specific Heat Btu/lb-°F (J/kg K)
1	Interior Films ¹	-	-	R-0.6 to R-1.1 (0.11 RSI to 0.20 RSI)	-	-
2	Gypsum Board	1/2" (30)	1.1 (0.16)	R-0.5 (0.08 RSI)	50 (800)	0.26 (1090)
3	1 5/8" x 1 5/8" Steel Studs (16" o.c.)	18 Gauge	430 (62)	-	489 (7830)	0.12 (500)
4	Air in Stud Cavity	3 5/8" (92)	-	R-0.9 (0.16 RSI)	0.075 (1.2)	0.24 (1000)
5	Concrete Wall	8" (203)	12.5 (1.8)	-	140 (2250)	0.20 (850)
6	Weather Resistive Barrier with Adhesive	-	-	-	-	-
7	Insulation Board	4" (100)	0.27 (0.039)	R-15 (2.64 RSI)	1 (16)	0.35 (1470)
8	Lamina	1/8" (4)	6 (0.9)	R-0.04 (0.01 RSI)	120 (1922)	0.20 (850)
9	Conventional curtain wall system: double glazed with minimal thermal break ² , double glazed IGU U _{IGU} = 0.32 BTU/hrft ² F (1.82 W/m ² K)					
10	Exterior Film ¹	-	-	R-0.2 (0.03 RSI)	-	-

¹ Value selected from table 1, p. 26.1 of 2009 ASHRAE Handbook – Fundamentals depending on surface orientation

² The thermal conductivity of air spaces within framing was found using ISO 100077-2

Detail 7.4.2

Precast Sandwich Panel Wall Assembly with 3 5/8" Steel Stud (16" o.c.) – Curtain Wall Spandrel Transition

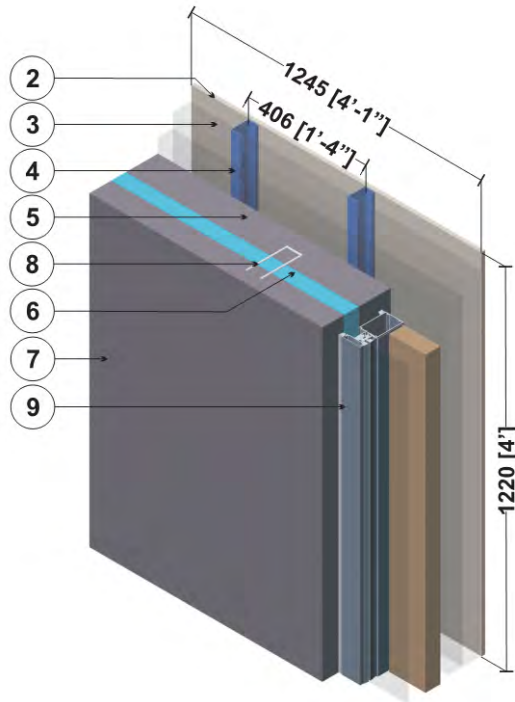

ID	Component	Thickness Inches (mm)	Conductivity Btu-in / ft ² ·hr·°F (W/m K)	Nominal Resistance hr·ft ² ·°F/Btu (m ² K/W)	Density lb/ft ³ (kg/m ³)	Specific Heat Btu/lb·°F (J/kg K)
1	Interior Film ¹	-	-	R-0.7 to R-1.1 (0.12 RSI to 0.20 RSI)	-	-
2	Gypsum Board	1/2" (13)	1.1 (0.16)	R-0.5 (0.08 RSI)	50 (800)	0.26 (1090)
3	Air in Stud Cavity	5 5/8" (143)	-	R-0.9 (0.16 RSI)	0.075 (1.2)	0.24 (1000)
4	3 5/8" Steel Studs	18 Gauge	430 (62)	-	489 (7830)	0.12 (500)
5	Precast Sandwich Panel, Interior Concrete	4" (102)	12.5 (1.8)	-	140 (2250)	0.20 (850)
6	Precast Sandwich Panel, Insulation	2" (50)	-	R-10 (1.8 RSI)	1.8 (28)	0.29 (1220)
7	Precast Sandwich Panel, Exterior Concrete	4" (102)	12.5 (1.8)	-	140 (2250)	0.20 (850)
8	Precast Sandwich Panel, Structural Ties @ 24" (610) o.c.	16 Gauge	430 (62)	-	489 (7830)	0.12 (500)
9	Conventional curtain wall system with insulated back pan (Pressure plates with minimal thermal break) ²					
10	Exterior Film ¹	-	-	R-0.2 (0.03 RSI)	-	-

¹ Value selected from table 1, p. 26.1 of 2009 ASHRAE Handbook – Fundamentals depending on surface orientation

² The thermal conductivity of air spaces within curtain wall framing was found using ISO 10077-2.

Detail 7.4.3

Interior Insulated Concrete Mass Wall – Conventional Curtain Wall Transition

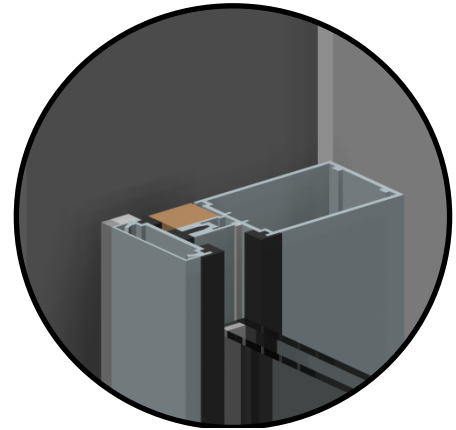
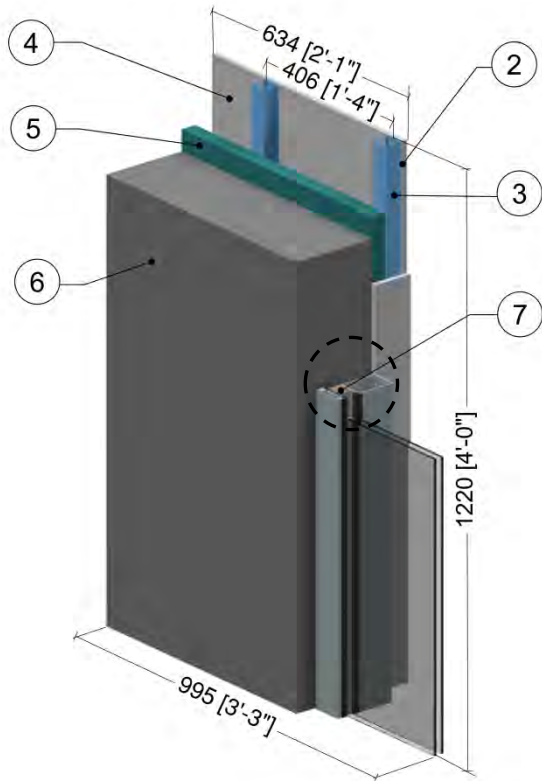

Curtain Wall Jamb Detail

ID	Component	Thickness Inches (mm)	Conductivity Btu-in / ft ² -hr-°F (W/m K)	Nominal Resistance hr-ft ² -°F/Btu (m ² K/W)	Density lb/ft ³ (kg/m ³)	Specific Heat Btu/lb-°F (J/kg K)
1	Interior Films ¹	-	-	R-0.7 to R-1.1 (0.12 RSI to 0.20 RSI)	-	-
2	Gypsum Board	1/2" (30)	1.1 (0.16)	R-0.5 (0.08 RSI)	50 (800)	0.26 (1090)
3	1 5/8" x 1 5/8" Steel Studs (16" o.c.)	18 Gauge	430 (62)	-	489 (7830)	0.12 (500)
4	Air in Stud Cavity	1 5/8" (41)	-	R-0.9 (0.16 RSI)	0.075 (1.2)	0.24 (1000)
5	Interior Insulation	2" (51)	-	R-10 (1.76 RSI)	1.8 (28)	0.29 (1220)
6	Concrete Wall	8" (203)	12.5 (1.8)	-	140 (2250)	0.20 (850)
7	Conventional curtain wall system: double glazed with minimal thermal break ² , double glazed IGU U _{IGU} = 0.32 BTU/hrft ² F (1.82 W/m ² K)					
8	Exterior Film ¹	-	-	R-0.2 (0.03 RSI)	-	-

¹ Value selected from table 1, p. 26.1 of 2009 ASHRAE Handbook – Fundamentals depending on surface orientation

² The thermal conductivity of air spaces within framing was found using ISO 100077-2

Detail 7.4.4

Interior Insulated Concrete Mass Wall – Thermally Broken Curtain Wall Transition

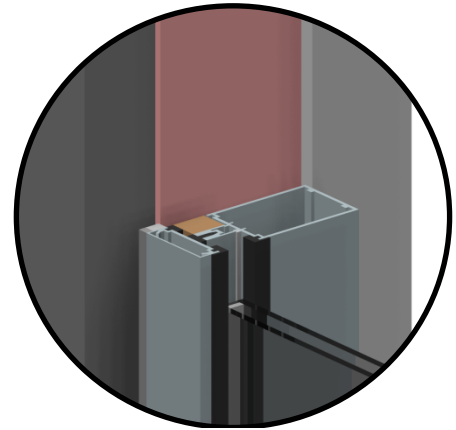
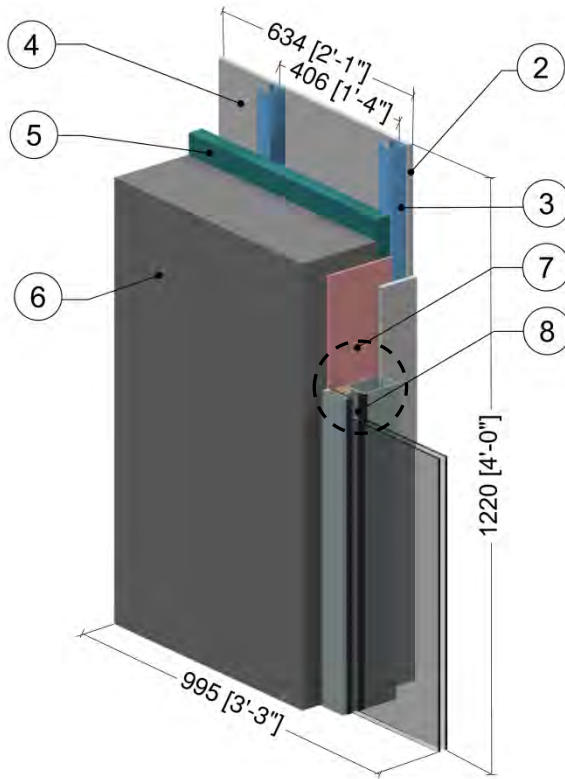

Curtain Wall Jamb Detail

ID	Component	Thickness Inches (mm)	Conductivity Btu-in / ft ² ·hr·°F (W/m K)	Nominal Resistance hr·ft ² ·°F/Btu (m ² K/W)	Density lb/ft ³ (kg/m ³)	Specific Heat Btu/lb·°F (J/kg K)
1	Interior Films ¹	-	-	R-0.7 to R-1.1 (0.12 RSI to 0.20 RSI)	-	-
2	Gypsum Board	1/2" (30)	1.1 (0.16)	R-0.5 (0.08 RSI)	50 (800)	0.26 (1090)
3	1 5/8" x 1 5/8" Steel Studs (16" o.c.)	18 Gauge	430 (62)	-	489 (7830)	0.12 (500)
4	Air in Stud Cavity	1 5/8" (41)	-	R-0.9 (0.16 RSI)	0.075 (1.2)	0.24 (1000)
5	Interior Insulation	2" (51)	-	R-10 (1.76 RSI)	1.8 (28)	0.29 (1220)
6	Concrete Wall	8" (203)	12.5 (1.8)	-	140 (2250)	0.20 (850)
7	Aerogel Blanket	0.4" (10)	0.1 (0.015)	R-3.8 (0.67 RSI)	-	-
8	Conventional curtain wall system: double glazed with minimal thermal break ² , double glazed IGU U _{IGU} = 0.32 BTU/hrft ² F (1.82 W/m ² K)					
9	Exterior Film ¹	-	-	R-0.2 (0.03 RSI)	-	-

¹ Value selected from table 1, p. 26.1 of 2009 ASHRAE Handbook – Fundamentals depending on surface orientation

² The thermal conductivity of air spaces within framing was found using ISO 100077-2

Detail 7.4.5

Precast Sandwich Panel Wall Assembly – Tigerloc Thermally Broken Curtain Wall Transition

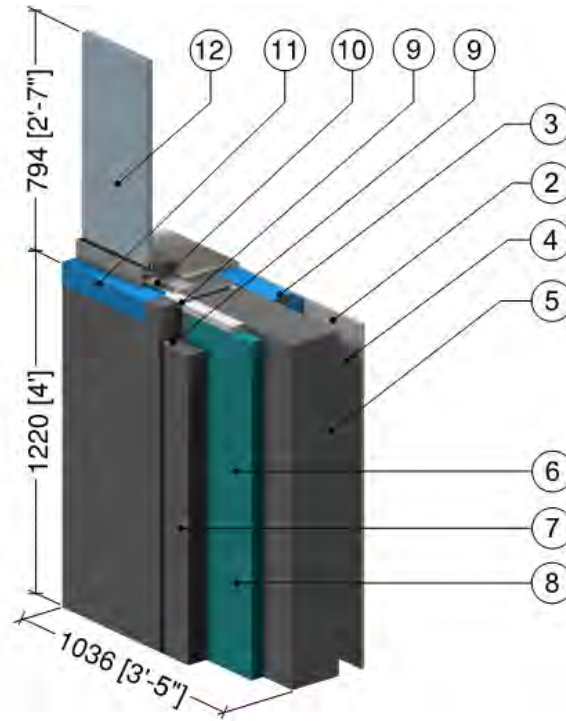

ID	Component	Thickness Inches (mm)	Conductivity Btu-in / ft ² ·hr·°F (W/m K)	Nominal Resistance hr·ft ² ·°F/Btu (m ² K/W)	Density lb/ft ³ (kg/m ³)	Specific Heat Btu/lb·°F (J/kg K)
1	Interior Film ¹	-	-	R-0.7 (0.12 RSI)	-	-
2	Gypsum Board	1/2" (13)	1.1 (0.16)	R-0.5 (0.08 RSI)	50 (800)	0.26 (1090)
3	3 5/8" x 1 5/8" Steel Studs with Top and Bottom Tracks	18 Gauge	430 (62)	-	489 (7830)	0.12 (500)
4	Air in Stud Cavity	4 1/8" (130)	-	R-0.9 (RSI-0.16)	0.075 (1.2)	0.24 (1000)
5	Precast Sandwich Panel, Interior Concrete Panel	7 3/4" (197)	12.5 (1.8)	-	140 (2250)	0.20 (850)
6	Precast Sandwich Panel Insulation	2" to 4" (51 to 102)	-	R-10 to R-20 (1.8 RSI to 3.5 RSI)	1.8 (28)	0.29 (1220)
7	Precast Sandwich Panel, Exterior Concrete Panel	3" (76)	12.5 (1.8)	-	140 (2250)	0.20 (850)
8	Precast Sandwich Panel, Structural Ties @ 24" (610) o.c.	16 Gauge	430 (62)	-	489 (7830)	0.12 (500)
9	Tigerloc, PVC Foam	1" (25)	0.42 (0.06)	-	-	-
10	Mineral Wool Sill Insulation	-	0.24 (0.034)	-	4 (64)	0.20 (850)
11	Sill Flashing	18 Gauge	430 (62)	-	489 (7830)	0.12 (500)
12	Conventional curtain wall system with insulated back pan (Pressure plates with minimal thermal break) ²					
13	Exterior Film ¹	-	-	R-0.2 (0.03 RSI)	-	-

¹ Value selected from table 1, p. 26.1 of 2009 ASHRAE Handbook – Fundamentals depending on surface orientation

² The thermal conductivity of air spaces within framing was found using ISO 100077-2

Detail 7.4.6

Highly Insulated Precast Concrete Sandwich Panel Wall Assembly – High Performance Aluminum Window Sill Detail

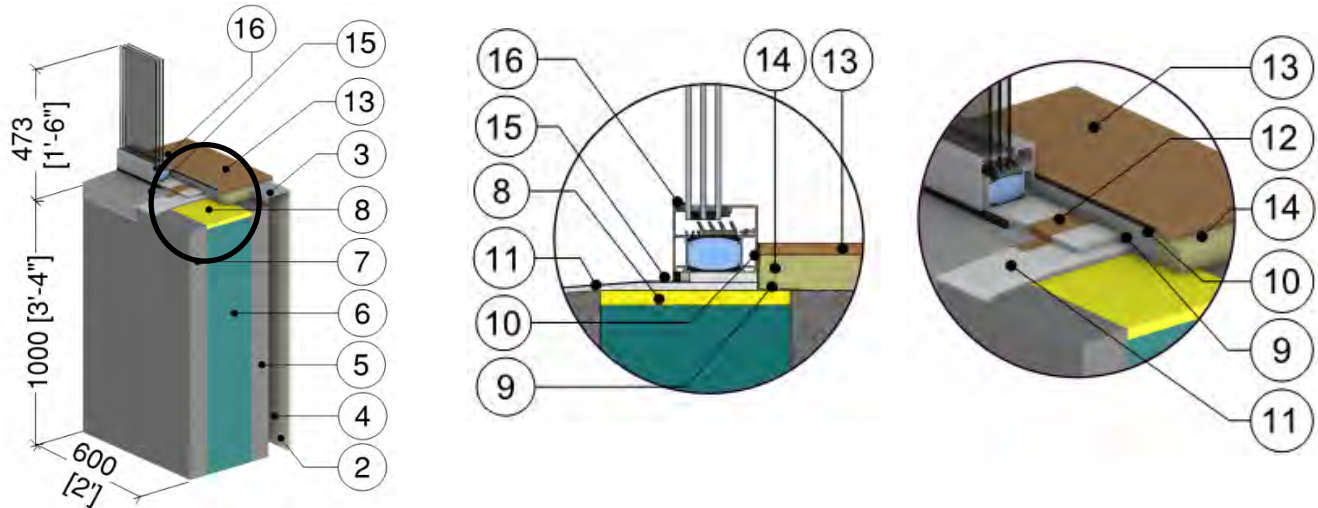

ID	Component	Thickness Inches (mm)	Conductivity Btu-in / ft ² ·hr·°F (W/m K)	Nominal Resistance hr·ft ² ·°F/Btu (m ² K/W)	Density lb/ft ³ (kg/m ³)	Specific Heat Btu/lb·°F (J/kg K)
1	Interior Film ¹	-	-	R-0.7 (0.12 RSI) to R-1.1 (0.2 RSI)	-	-
2	Gypsum Board	5/8" (15)	1.1 (0.16)	R-0.5 (0.09 RSI)	50 (800)	0.26 (1090)
3	3 5/8" x 1 5/8" Steel Studs with Top and Bottom Tracks	18 Gauge	430 (62)	-	489 (7830)	0.12 (500)
4	Air in Stud Cavity	3 5/8" (92)	-	R-0.9 (0.16 RSI)	0.075 (1.2)	0.24 (1000)
5	Precast Sandwich Panel, Interior Concrete Panel	3" (76)	12.5 (1.8)	-	140 (2250)	0.20 (850)
6	Precast Sandwich Panel Insulation	8" (203)	-	R-40 (7.04 RSI) to R-56 (9.86 RSI)	1.8 (28)	0.29 (1220)
7	Precast Sandwich Panel, Exterior Concrete Panel	3" (76)	12.5 (1.8)	-	140 (2250)	0.20 (850)
8	Exterior Gypsum Closure	5/8" (15)	1.1 (0.16)	-	50 (800)	0.26 (1090)
9	Angle	-	430 (62)	-	489 (7830)	0.12 (500)
10	Sealant	-	1.73 (0.25)	-	-	-
11	Sill Insulation Below Frame, Spray Foam or Aerogel	-	0.167 (0.024) to 0.1 (0.014)	-	2.4 (39)	0.35 (1470)
12	Shims	-	0.69 (0.1)	-	-	-
13	Wood Sill	1/2" (13)	0.69 (0.1)	-	31 (500)	0.45 (1880)
14	Sill Insulation Behind Frame, Mineral Wool	-	0.238 (0.034)	-	4 (64)	0.20 (850)
15	Flashing	18 Gauge	430 (62)	-	489 (7830)	0.12 (500)
16	Raico Frame+ Aluminum Frame, triple glazed thermally broken window triple glazed IGU U _{IGU} = 0.12 Btu/hr·ft ² ·°F (0.7 W/m ² K) ²					
17	Exterior Film ¹	-	-	R-0.2 (0.03 RSI)	-	-

¹ Value selected from table 1, p. 26.1 of 2009 ASHRAE Handbook – Fundamentals depending on surface orientation

² The thermal conductivity of airspaces within framing was found using ISO 100077-2



Detail 7.4.7

Highly Insulated Precast Concrete Sandwich Panel Wall Assembly – High Performance Aluminum Window Head Detail

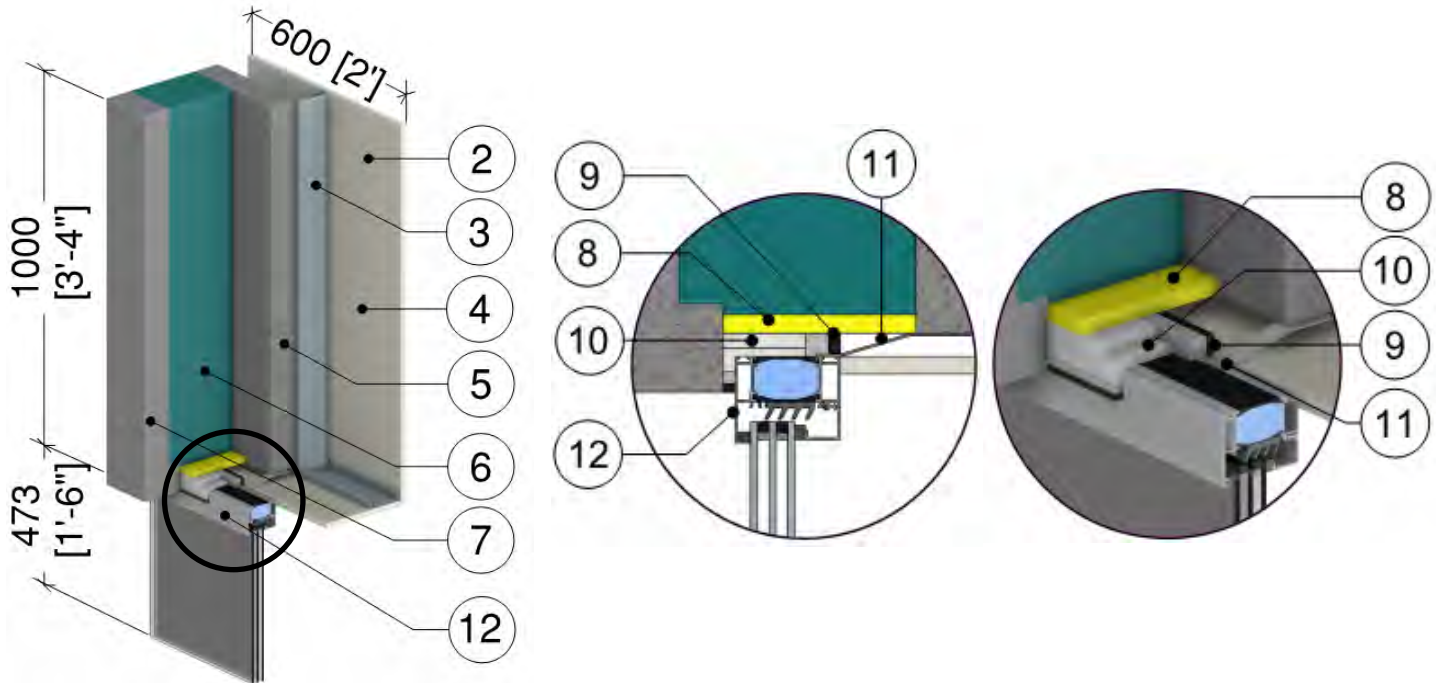

ID	Component	Thickness Inches (mm)	Conductivity Btu-in / ft ² ·hr·°F (W/m K)	Nominal Resistance hr·ft ² ·°F/Btu (m ² K/W)	Density lb/ft ³ (kg/m ³)	Specific Heat Btu/lb·°F (J/kg K)
1	Interior Film ¹	-	-	R-0.7 (0.12 RSI) to R-1.1 (0.2 RSI)	-	-
2	Gypsum Board	5/8" (15)	1.1 (0.16)	R-0.5 (0.09 RSI)	50 (800)	0.26 (1090)
3	3 5/8" x 1 5/8" Steel Studs with Top and Bottom Tracks	18 Gauge	430 (62)	-	489 (7830)	0.12 (500)
4	Air in Stud Cavity	3 5/8" (92)	-	R-0.9 (0.16 RSI)	0.075 (1.2)	0.24 (1000)
5	Precast Sandwich Panel, Interior Concrete Panel	3" (76)	12.5 (1.8)	-	140 (2250)	0.20 (850)
6	Precast Sandwich Panel Insulation	8" (203)	-	R-40 (7.04 RSI) to R-56 (9.86 RSI)	1.8 (28)	0.29 (1220)
7	Precast Sandwich Panel, Exterior Concrete Panel	3" (76)	12.5 (1.8)	-	140 (2250)	0.20 (850)
8	Exterior Gypsum Closure	5/8" (15)	1.1 (0.16)	-	50 (800)	0.26 (1090)
9	Sealant	-	1.73 (0.25)	-	-	-
10	Opening Insulation, Spray Foam or Aerogel	-	0.167 (0.024) to 0.1 (0.014)	-	2.4 (39)	0.35 (1470)
11	Window Straps	-	430 (62)	-	489 (7830)	0.12 (500)
12	Raico Frame+ Aluminum Frame, triple glazed thermally broken window triple glazed IGU U _{IGU} = 0.12 Btu/hr·ft ² ·°F (0.7 W/m ² K) ²					
13	Exterior Film ¹	-	-	R-0.2 (0.03 RSI)	-	-

¹ Value selected from table 1, p. 26.1 of 2009 ASHRAE Handbook – Fundamentals depending on surface orientation

² The thermal conductivity of airspaces within framing was found using ISO 10077-2

Detail 7.5.1

Exterior Insulated Concrete Drained EIFS Wall Assembly – Concrete Parapet & Slab Intersection

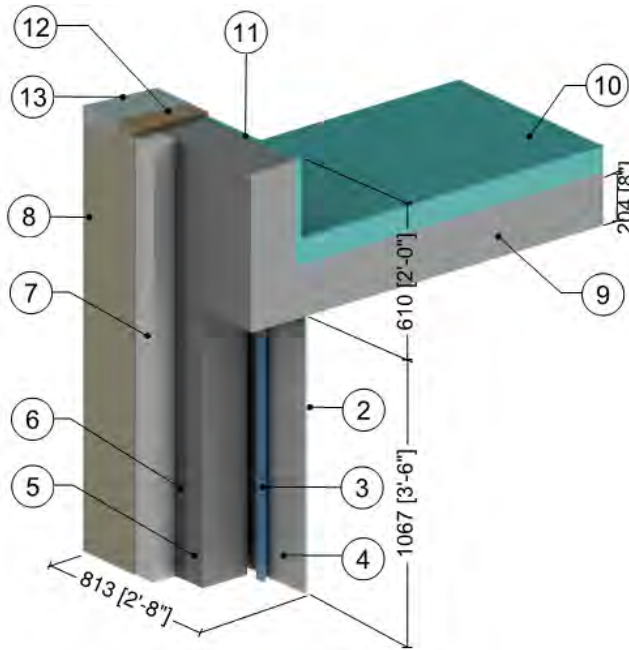

ID	Component	Thickness Inches (mm)	Conductivity Btu-in / ft ² -hr-°F (W/m K)	Nominal Resistance hr-ft ² -°F/Btu (m ² K/W)	Density lb/ft ³ (kg/m ³)	Specific Heat Btu/lb-°F (J/kg K)
1	Interior Films ¹	-	-	R-0.6 to R-0.7 (0.11 RSI to 0.12 RSI)	-	-
2	Gypsum Board	1/2" (13)	1.1 (0.16)	R-0.5 (0.08 RSI)	50 (800)	0.26 (1090)
3	1 5/8" x 1 5/8" Steel Studs (16"o.c.) with Top Tracks	18 Gauge	430 (62)	-	489 (7830)	0.12 (500)
4	Air in Stud Cavity	1 5/8" (41)	-	R-0.9 (0.16 RSI)	0.075 (1.2)	0.24 (1000)
5	Concrete Wall	8" (203)	12.5 (1.8)	-	140 (2250)	0.20 (850)
6	Weather Resistive Barrier with Adhesive	-	-	-	-	-
7	Insulation Board	4" (100)	0.27 (0.039)	R-15 (2.64 RSI)	1 (16)	0.35 (1470)
8	Lamina	1/8" (4)	6 (0.9)	R-0.04 (0.01 RSI)	120 (1922)	0.20 (850)
9	Concrete Slab & Parapet	8" (203)	12.5 (1.8)	-	140 (2250)	0.20 (850)
10	Roof Insulation	4" (100)	-	R-20 (3.5 RSI)	1.8 (28)	0.29 (1220)
11	Parapet Insulation	1" (25)	-	R-5 (0.88 RSI)	1.8 (28)	0.29 (1220)
12	Wood Blocking	5/8" (16)	0.63 (0.09)	-	27.8 (445)	0.45 (1880)
13	Flashing & roof finish material are incorporated into exterior heat transfer coefficient					
14	Exterior Film ¹	-	-	R-0.2 to R-0.7 (0.03 RSI to 0.12 RSI)	-	-

¹ Value selected from table 1, p. 26.1 of 2009 ASHRAE Handbook – Fundamentals depending on surface orientation

Detail 7.5.2

Exterior Insulated Concrete Drained EIFS Wall Assembly – Insulated Concrete Parapet & Slab Intersection

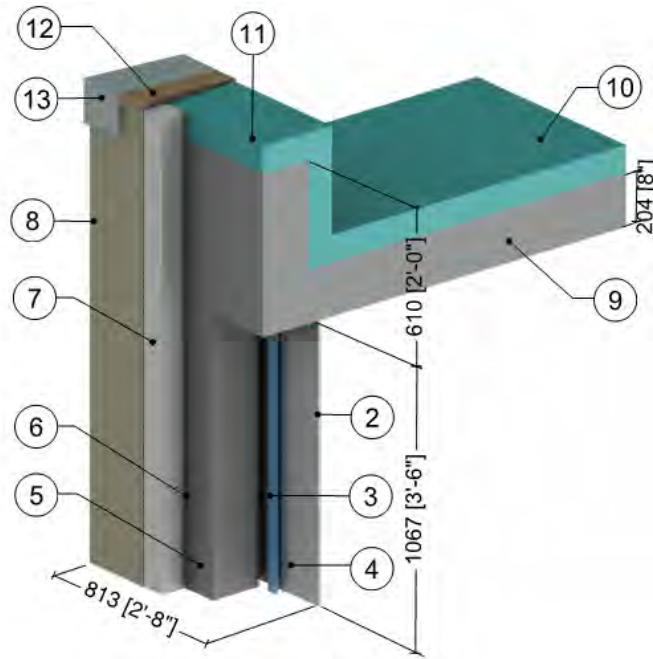

ID	Component	Thickness Inches (mm)	Conductivity Btu-in / ft ² ·hr·°F (W/m K)	Nominal Resistance hr·ft ² ·°F/Btu (m ² K/W)	Density lb/ft ³ (kg/m ³)	Specific Heat Btu/lb·°F (J/kg K)
1	Interior Films ¹	-	-	R-0.6 to R-0.7 (0.11 RSI to 0.12 RSI)	-	-
2	Gypsum Board	1/2" (13)	1.1 (0.16)	R-0.5 (0.08 RSI)	50 (800)	0.26 (1090)
3	1 5/8" x 1 5/8" Steel Studs (16"o.c.) with Top Tracks	18 Gauge	430 (62)	-	489 (7830)	0.12 (500)
4	Air in Stud Cavity	1 5/8" (41)	-	R-0.9 (0.16 RSI)	0.075 (1.2)	0.24 (1000)
5	Concrete	8" (203)	12.5 (1.8)	-	140 (2250)	0.20 (850)
6	Weather Resistive Barrier with Adhesive	-	-	-	-	-
7	Insulation Board	4" (100)	0.27 (0.039)	R-15 (2.64 RSI)	1 (16)	0.35 (1470)
8	Lamina	1/8" (4)	6 (0.9)	R-0.04 (0.01 RSI)	120 (1922)	0.20 (850)
9	Concrete Slab & Parapet	8" (203)	12.5 (1.8)	-	140 (2250)	0.20 (850)
10	Roof Insulation	4" (100)	-	R-20 (3.5 RSI)	1.8 (28)	0.29 (1220)
11	Parapet Insulation	Varies	-	R-10 to R-20 (1.76 RSI to 3.52 RSI)	1.8 (28)	0.29 (1220)
12	Wood Blocking	5/8" (16)	0.63 (0.09)	-	27.8 (445)	0.45 (1880)
13	Flashing & roof finish material are incorporated into exterior heat transfer coefficient					
14	Exterior Film ¹	-	-	R-0.2 to R-0.7 (0.03 RSI to 0.12 RSI)	-	-

¹ Value selected from table 1, p. 26.1 of 2009 ASHRAE Handbook – Fundamentals depending on surface orientation

Detail 7.5.3

Interior Insulated Concrete Mass Wall with 1 5/8" Steel Stud (16" o.c.) Supporting Interior Finish – Concrete Parapet & Roof Intersection

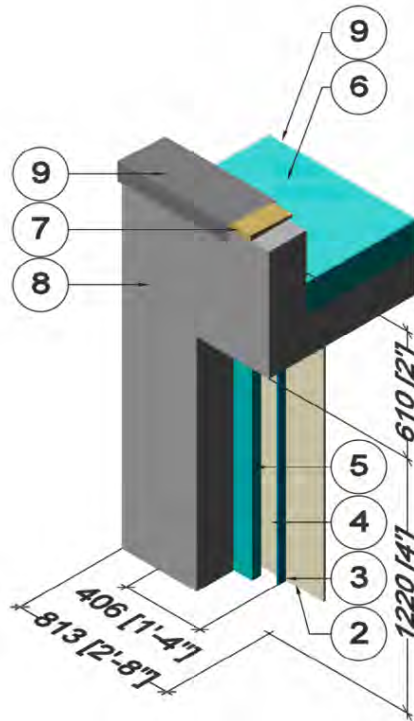

ID	Component	Thickness Inches (mm)	Conductivity Btu-in / ft ² ·hr·°F (W/m K)	Nominal Resistance hr·ft ² ·°F/Btu (m ² K/W)	Density lb/ft ³ (kg/m ³)	Specific Heat Btu/lb·°F (J/kg K)
1	Interior Film ¹	-	-	R-0.6 to R-0.7 (0.11 RSI to 0.12 RSI)	-	-
2	Gypsum Board	1/2" (13)	1.1 (0.16)	R-0.5 (0.08 RSI)	50 (800)	0.26 (1090)
3	1 5/8" Steel Studs with Top Tracks	20 Gauge	430 (62)	-	489 (7830)	0.12 (500)
4	Air in Stud Cavity	1 5/8" (42)	-	R-0.9 (0.16 RSI)	0.075 (1.2)	0.24 (1000)
5	Interior Insulation	2" (51)	0.2 (0.03)	R-11 (1.9 RSI)	1.8 (28)	0.29 (1220)
6	Roof Insulation	4" (102)	-	R-20 (3.5 RSI)	1.8 (28)	0.29 (1220)
7	Wood Blocking	5/8" (16)	0.63 (0.09)	-	27.8 (445)	0.45 (1880)
8	Concrete Slab & Parapet	8" (203)	12.5 (1.8)	-	140 (2250)	0.20 (850)
9	Metal cap flashing/ finish roof material is incorporated into exterior heat transfer coefficient					
10	Exterior Film ¹	-	-	R-0.2 (0.03 RSI)	-	-

¹ Value selected from table 1, p. 26.1 of 2009 ASHRAE Handbook – Fundamentals depending on surface orientation

Detail 7.5.4

Precast Sandwich Panel Wall Assembly with 3 5/8" Steel Stud (16" o.c.) – Steel Roof Deck with Open Web Steel Joist & Parapet Intersection

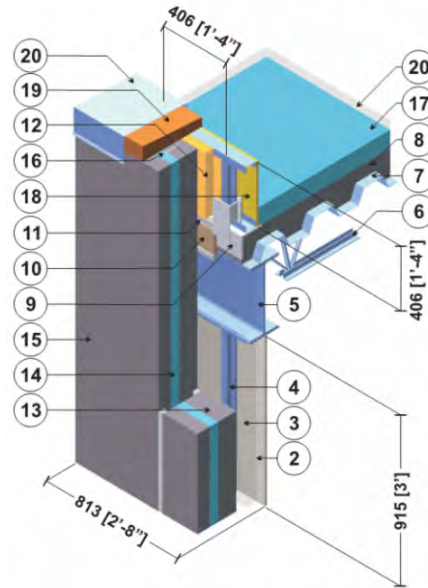

ID	Component	Thickness Inches (mm)	Conductivity Btu-in / ft ² -hr-°F (W/m K)	Nominal Resistance hr-ft ² -°F/Btu (m ² K/W)	Density lb/ft ³ (kg/m ³)	Specific Heat Btu/lb-°F (J/kg K)
1	Interior Film ¹	-	-	R-0.6 to R-0.7 (0.11 RSI to 0.12 RSI)	-	-
2	Gypsum Board	1/2" (13)	1.1 (0.16)	R-0.5 (0.08 RSI)	50 (800)	0.26 (1090)
3	Air in Stud Cavity	5 5/8" (143)	-	R-0.9 (0.16 RSI)	0.075 (1.2)	0.24 (1000)
4	3 5/8" Steel Studs with Top and Bottom Tracks	18 Gauge	430 (62)	-	489 (7830)	0.12 (500)
5	Steel Beam (W410)	-	347 (50)	-	489 (7830)	0.12 (500)
6	Open Web Steel Joist (550C)	-	347 (50)	-	489 (7830)	0.12 (500)
7	Steel Deck	1/16" (1.6)	347 (50)	-	489 (7830)	0.12 (500)
8	Concrete Topping	6" (152)	6.3 (0.9)	-	120 (1920)	0.20 (850)
9	Gravity and Slot Anchors at Slab	-	347 (50)	-	489 (7830)	0.12 (500)
10	Semi Rigid Insulation	1" (25)	0.28 (0.04)	R-3.6 (0.64 RSI)	4.5 (72)	0.17 (710)
11	Silicone Sealant	-	2.4 (0.35)	-	-	-
12	Spray Foam Insulation	2" (51)	0.17 (0.025)	R-11.5 (2.0 RSI)	2.8 (39)	0.35 (1470)
13	Precast Sandwich Panel, Interior Concrete Panel	4" (102)	12.5 (1.8)	-	140 (2250)	0.20 (850)
14	Precast Sandwich Panel, Insulation	2" (51)	-	R-10 (1.8 RSI)	1.8 (28)	0.29 (1220)
15	Precast Sandwich Panel, Exterior Concrete Panel	4" (102)	12.5 (1.8)	-	140 (2250)	0.20 (850)
16	Precast Sandwich Panel, Structural Ties @ 24" (610) o.c.	16 Gauge	430 (62)	-	489 (7830)	0.12 (500)
17	Roof Insulation	4" (102)	-	R-20 (3.5 RSI)	1.8 (28)	0.29 (1220)
18	Exterior Sheathing	1/2" (13)	1.1 (0.16)	R-0.5 (0.08 RSI)	50 (800)	0.26 (1090)
19	Wood Blocking	5/8" (16)	0.63 (0.09)	-	27.8 (445)	0.45 (1880)
20	Flashing & roof finish material are incorporated into exterior heat transfer coefficient					
21	Exterior Film ¹	-	-	R-0.2 (0.03 RSI)	-	-

¹ Value selected from table 1, p. 26.1 of 2009 ASHRAE Handbook – Fundamentals depending on surface orientation



Detail 7.5.5

Precast Sandwich Panel – Steel Roof Deck with Open Web Steel Joist & Parapet Intersection

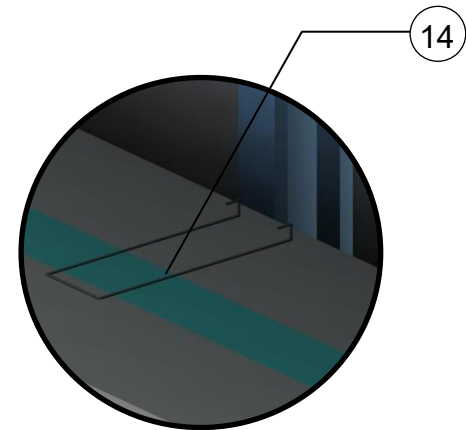
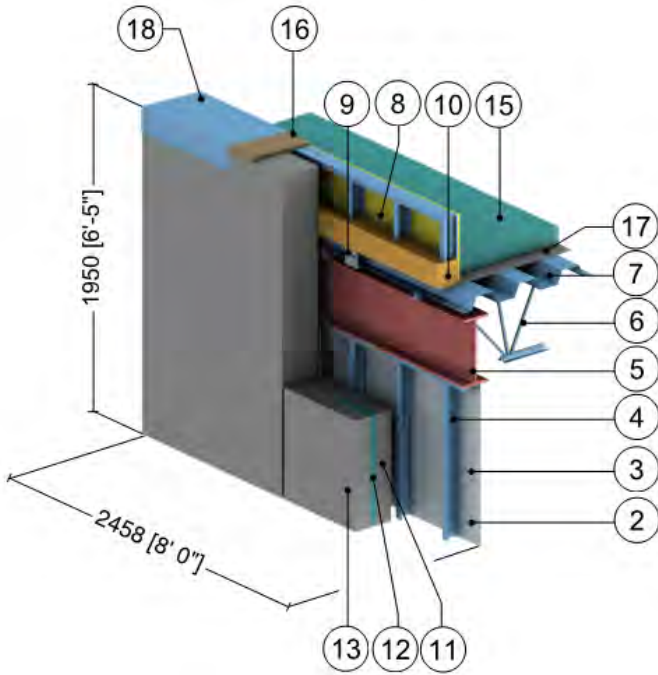

Connector Detail

ID	Component	Thickness Inches (mm)	Conductivity Btu-in / ft ² -hr-°F (W/m K)	Nominal Resistance hr-ft ² -°F/Btu (m ² K/W)	Density lb/ft ³ (kg/m ³)	Specific Heat Btu/lb-°F (J/kg K)
1	Interior Film ¹	-	-	R-0.6 to R-0.7 (0.11 RSI to 0.12 RSI)	-	-
2	Gypsum Board	1/2" (13)	1.1 (0.16)	R-0.5 (0.08 RSI)	50 (800)	0.26 (1090)
3	Air in Stud Cavity	5 5/8" (143)	-	R-0.9 (0.16 RSI)	0.075 (1.2)	0.24 (1000)
4	3 5/8" Steel Studs with Top and Bottom Tracks	18 Gauge	430 (62)	-	489 (7830)	0.12 (500)
5	Steel Beam (W410)	-	347 (50)	-	489 (7830)	0.12 (500)
6	Open Web Steel Joist (550C)	-	347 (50)	-	489 (7830)	0.12 (500)
7	Steel Deck	1/16" (1.6)	347 (50)	-	489 (7830)	0.12 (500)
8	Exterior Sheathing	1/2" (13)	1.1 (0.16)	R-0.5 (0.08 RSI)	50 (800)	0.26 (1090)
9	Gravity and Slot Anchors at Slab	-	347 (50)	-	489 (7830)	0.12 (500)
10	Polyurethane Foam Insulation	5 2/3" (144)	0.17 (0.024)	R-34 (6.0 RSI)	2.8 (30)	0.35 (1470)
11	Precast Sandwich Panel, Interior Concrete	4" (102)	12.5 (1.8)	-	140 (2250)	0.20 (850)
12	Precast Sandwich Panel, Insulation	2" (51)	-	R-10 (1.76 RSI)	1.8 (28)	0.29 (1220)
13	Precast Sandwich Panel, Exterior Concrete	4" (102)	12.5 (1.8)	-	140 (2250)	0.20 (850)
14	Precast Sandwich Panel, Steel Structural Ties @ 24" (610) o.c.	16 Gauge	430 (62)	-	489 (7830)	0.12 (500)
15	Roof Insulation	4" (102)	-	R-20 (3.5 RSI)	1.8 (28)	0.29 (1220)
16	Wood Blocking	5/8" (16)	0.69 (0.10)	-	31 (500)	0.45 (1880)
17	Roof Sheathing	1/2" (13)	0.69 (0.10)	R-0.7 (0.12 RSI)	31 (500)	0.45 (1880)
18	Flashing & roof finish material are incorporated into exterior heat transfer coefficient					
19	Exterior Film ¹	-	-	R-0.2 (0.03 RSI)	-	-

¹ Value selected from table 1, p. 26.1 of 2009 ASHRAE Handbook – Fundamentals depending on surface orientation

Detail 7.5.6

Precast Wall Assembly with 3 5/8" x 1 5/8" Steel Stud (16" o.c.) and Rigid Insulation Outboard of Studs – Parapet & Roof Intersection

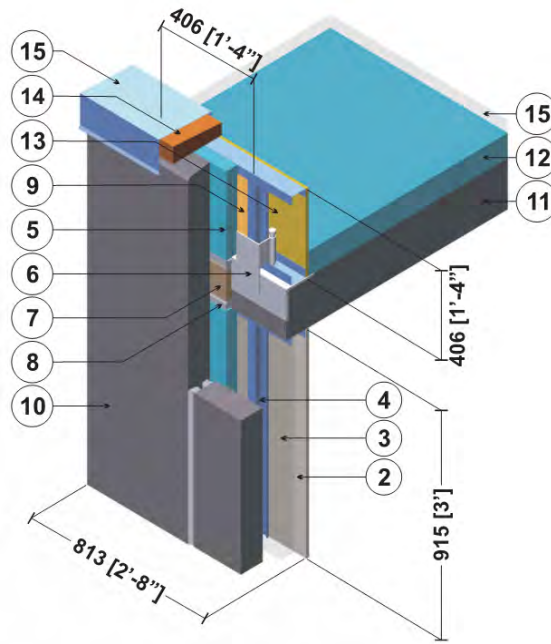

ID	Component	Thickness Inches (mm)	Conductivity Btu-in / ft ² -hr-°F (W/m K)	Nominal Resistance hr-ft ² -°F/Btu (m ² K/W)	Density lb/ft ³ (kg/m ³)	Specific Heat Btu/lb-°F (J/kg K)
1	Interior Film ¹	-	-	R-0.6 to R-0.7 (0.11 RSI to 0.12 RSI)	-	-
2	Gypsum Board	1/2" (13)	1.1 (0.16)	R-0.5 (0.08 RSI)	50 (800)	0.26 (1090)
3	Air in Stud Cavity	3 5/8" (92)	-	R-0.9 (0.16 RSI)	0.075 (1.2)	0.24 (1000)
4	3 5/8" x 1 5/8" Steel Studs with Top and Bottom Tracks	18 Gauge	430 (62)	-	489 (7830)	0.12 (500)
5	Rigid Insulation	2" (51)	-	R-10 (1.8 RSI)	1.8 (28)	0.29 (1220)
6	Gravity and Slot Anchors at Roof	-	347 (50)	-	489 (7830)	0.12 (500)
7	Semi Rigid Insulation	1" (25)	0.28 (0.04)	R-3.6 (0.64 RSI)	4.5 (72)	0.17 (710)
8	Silicone Sealant	-	2.4 (0.35)	-	-	-
9	Spray Foam Insulation	1" (25)	0.17 (0.025)	R-5.8 (1.02 RSI)	2.8 (39)	0.35 (1470)
10	Precast Wall Panel	4" (102)	12.5 (1.8)	-	140 (2250)	0.20 (850)
11	Concrete Slab	8" (203)	12.5 (1.8)	-	140 (2250)	0.20 (850)
12	Roof Insulation	4" (102)	-	R-20 (3.5 RSI)	1.8 (28)	0.29 (1220)
13	Exterior Sheathing	1/2" (13)	1.1 (0.16)	R-0.5 (0.08 RSI)	50 (800)	0.26 (1090)
14	Wood Blocking	5/8" (16)	0.63 (0.09)	-	27.8 (445)	0.45 (1880)
15	Flashing & roof finish materials are incorporated into exterior heat transfer coefficient					
16	Exterior Film ¹	-	-	R-0.2 (0.03 RSI)	-	-

¹ Value selected from table 1, p. 26.1 of 2009 ASHRAE Handbook – Fundamentals depending on surface orientation

Detail 7.5.7

Precast Wall Assembly with 3 5/8" x 1 5/8" Steel Stud (16" o.c.) and Rigid Insulation Outboard of Studs – Parapet & Roof Intersection with Thermal Break under Parapet Stud Cavity and At Anchors

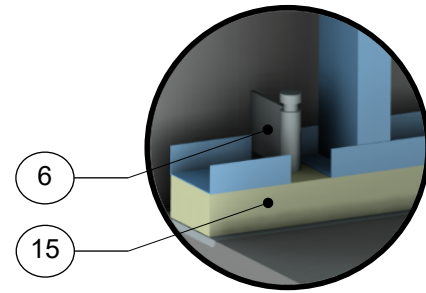
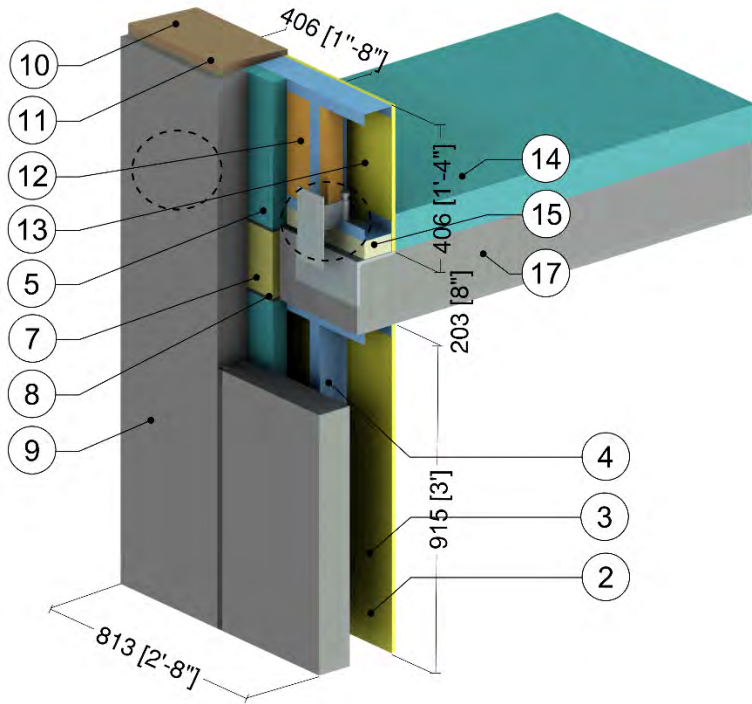

Gravity Anchor Detail

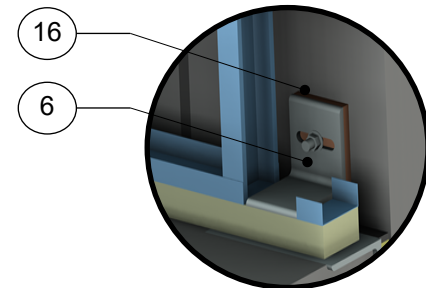

Slot Anchor Detail

ID	Component	Thickness Inches (mm)	Conductivity Btu-in / ft ² ·hr·°F (W/m K)	Nominal Resistance hr·ft ² ·°F/Btu (m ² K/W)	Density lb/ft ³ (kg/m ³)	Specific Heat Btu/lb·°F (J/kg K)	
1	Interior Film ¹	-	-	R-0.6 to R-0.7 (0.11 RSI to 0.12 RSI)	-	-	
2	Gypsum Board	1/2" (13)	1.1 (0.16)	R-0.5 (0.08 RSI)	50 (800)	0.26 (1090)	
3	Air in Stud Cavity	3 5/8" (92)	-	R-0.9 (0.16 RSI)	0.075 (1.2)	0.24 (1000)	
4	3 5/8" x 1 5/8" Steel Studs with Top and Bottom Tracks	18 Gauge	430 (62)	-	489 (7830)	0.12 (500)	
5	Rigid Insulation	2" (51)	-	R-10 (1.8 RSI)	1.8 (28)	0.29 (1220)	
6	Gravity and Slot Anchors at Roof	-	347 (50)	-	489 (7830)	0.12 (500)	
7	Semi Rigid Insulation	1" (25)	0.28 (0.04)	R-3.6 (0.64 RSI)	4.5 (72)	0.17 (710)	
8	Silicone Sealant	-	2.4 (0.35)	-	-	-	
9	Precast Wall Panel	4" (102)	12.5 (1.8)	-	140 (2250)	0.20 (850)	
10	Flashing & roof finish materials are incorporated into exterior heat transfer coefficient						
11	Wood Blocking	5/8" (16)	0.63 (0.09)	-	27.8 (445)	0.45 (1880)	
12	Spray Foam Insulation	1" (25)	0.17 (0.025)	R-5.8 (1.02 RSI)	2.8 (39)	0.35 (1470)	
13	Exterior Sheathing	1/2" (13)	1.1 (0.16)	R-0.5 (0.08 RSI)	50 (800)	0.26 (1090)	
14	Roof Insulation	4" (102)	-	R-20 (3.5 RSI)	1.8 (28)	0.29 (1220)	
15	Armatherm 500	2" (50)	0.32 (0.05)	R-6.2 (1.09 RSI)	-	-	
16	Armatherm FRR	3/8" (10)	1.4 (0.20)	-	85 (5.3)	-	
17	Concrete Slab	8" (203)	12.5 (1.8)	-	140 (2250)	0.20 (850)	
18	Exterior Film ¹	-	-	R-0.2 (0.03 RSI)	-	-	

¹ Value selected from table 1, p. 26.1 of 2009 ASHRAE Handbook – Fundamentals depending on surface orientation

Detail 7.5.8

Exterior Insulated Concrete Block Wall Assembly with Masonry Ties Supporting Brick Veneer – Parapet & Roof Intersection

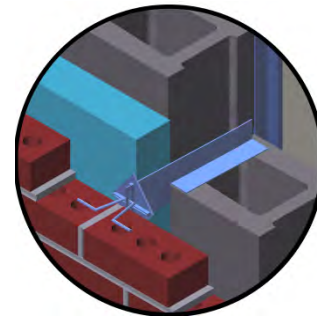
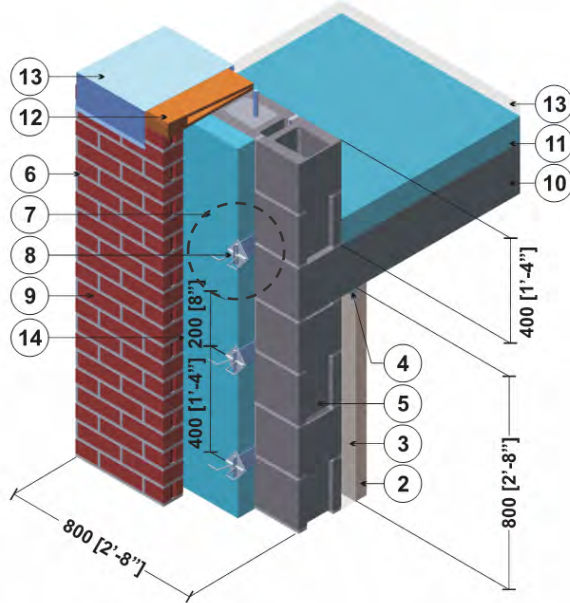

Brick Tie Detail

ID	Component	Thickness Inches (mm)	Conductivity Btu-in / ft ² ·hr·°F (W/m K)	Nominal Resistance hr·ft ² ·°F/Btu (m ² K/W)	Density lb/ft ³ (kg/m ³)	Specific Heat Btu/lb·°F (J/kg K)
1	Interior Film ¹	-	-	R-0.6 to R-0.7 (0.11 RSI to 0.12 RSI)	-	-
2	Gypsum Board	1/2" (13)	1.1 (0.16)	R-0.5 (0.08 RSI)	50 (800)	0.26 (1090)
3	Air in Stud Cavity	1 5/8" (41)	-	R-0.9 (0.16 RSI)	0.075 (1.2)	0.24 (1000)
4	1 5/8" Steel Studs with Metal Tracks	20 Gauge	430 (62)	-	489 (7830)	0.12 (500)
5	Standard Concrete Block	7 5/8" (190)	3.5 (0.5)	-	119 (1900)	0.19 (800)
6	Cement Mortar	-	3.5 (0.5)	-	113 (1800)	0.12 (500)
7	Insulation	Varies	-	R-5 to R-25 (0.88 RSI to 4.4 RSI)	1.8 (28)	0.29 (1220)
8	Masonry Ties @ 16" (406) o.c.	16 Gauge	430 (62)	-	489 (7830)	0.12 (500)
9	Brick Veneer	3 5/8" (92)	5.4 (0.78)	-	120 (1920)	0.19 (720)
10	Concrete Slab	8" (203)	12.5 (1.8)	-	140 (2250)	0.20 (850)
11	Roof Insulation	4" (102)	-	R-20 (3.5 RSI)	1.8 (28)	0.29 (1220)
12	Wood Blocking	5/8" (16)	0.63 (0.09)	-	27.8 (445)	0.45 (1880)
13	Flashing & roof finish materials are incorporated into exterior heat transfer coefficient					
14	Air Gap	1" (25)	-	R-0.9 (0.16 RSI)	0.075 (1.2)	0.24 (1000)
15	Exterior Film ¹	-	-	R-0.2 (0.03 RSI)	-	-

¹ Value selected from table 1, p. 26.1 of 2009 ASHRAE Handbook – Fundamentals depending on surface orientation

Detail 7.5.9

Precast Sandwich Panel – Steel Roof Deck with Open Web Steel Joist & Paroloc Thermally Broken Parapet Intersection

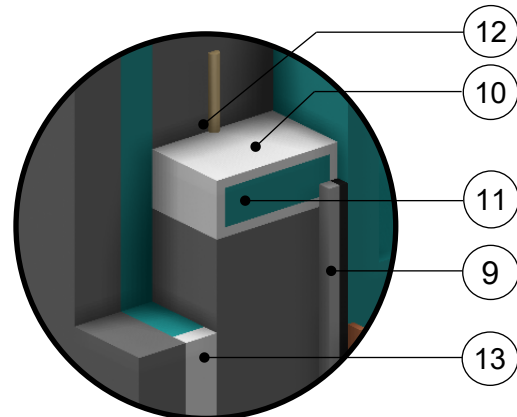
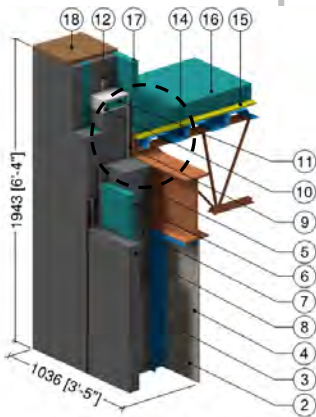

ID	Component	Thickness Inches (mm)	Conductivity Btu-in / ft ² ·hr·°F (W/m K)	Nominal Resistance hr·ft ² ·°F/Btu (m ² K/W)	Density lb/ft ³ (kg/m ³)	Specific Heat Btu/lb·°F (J/kg K)
1	Interior Film ¹	-	-	R-0.6 to R-0.7 (0.11 RSI to 0.12 RSI)	-	-
2	Gypsum Board	1/2" (13)	1.1 (0.16)	R-0.5 (0.08 RSI)	50 (800)	0.26 (1090)
3	3 5/8" x 1 5/8" Steel Studs with Top and Bottom Tracks	18 Gauge	430 (62)	-	489 (7830)	0.12 (500)
4	Air in Stud Cavity	4 1/8" (130)	-	R-0.9 (RSI-0.16)	0.075 (1.2)	0.24 (1000)
5	Precast Sandwich Panel, Interior Concrete Panel	7 3/4" (197)	12.5 (1.8)	-	140 (2250)	0.20 (850)
6	Precast Sandwich Panel Insulation	2" to 4" (51 to 102)	-	R-10 (1.8 RSI) to R-20 (3.5 RSI)	1.8 (28)	0.29 (1220)
7	Precast Sandwich Panel, Exterior Concrete Panel	3" (76)	12.5 (1.8)	-	140 (2250)	0.20 (850)
8	Precast Sandwich Panel, Structural Ties @ 24" (610) o.c.	16 Gauge	430 (62)	-	489 (7830)	0.12 (500)
9	Silicone Sealant	-	1.7 (0.25)	-	-	-
10	Paraloc, PVC Foam	1/2" (13)	0.42 (0.06)	-	-	-
11	Paraloc, Insulation	2" to 4" (51 to 102)	-	R-10 to R-20 (1.8 RSI to 3.5 RSI)	1.8 (28)	0.29 (1220)
12	FRP rebar @ 10" (254) o.c.	#5 (16M)	2.4 (0.35)	-	-	-
13	Tigerloc, PVC Foam	1" (25)	0.42 (0.06)	-	-	-
14	Open Web Steel Joist, Beam, Angle, and Deck	-	347 (50)	-	489 (7830)	0.12 (500)
15	Exterior Sheathing	5/8" (16)	1.1 (0.16)	R-0.6 (0.1 RSI)	50 (800)	0.26 (1090)
16	Roof Insulation	4" (102)	-	R-20 (3.5 RSI)	1.8 (28)	0.29 (1220)
17	Parapet Insulation	2" to 4" (51 to 102)	-	R-10 to R-20 (1.8 RSI to 3.5 RSI)	1.8 (28)	0.29 (1220)
18	Wood Blocking	5/8" (16)	0.63 (0.09)	-	27.8 (445)	0.45 (1880)
19	Flashing and roof finish material are incorporated into exterior heat transfer coefficient					
20	Exterior Film ¹	-	-	R-0.2 (0.03 RSI)	-	-

¹ Value selected from table 1, p. 26.1 of 2009 ASHRAE Handbook – Fundamentals depending on surface orientation

Detail 7.5.10

Highly Insulated Precast Concrete Sandwich Panel Wall Assembly – Roof to Wall Intersection with Wood-Framed Parapet

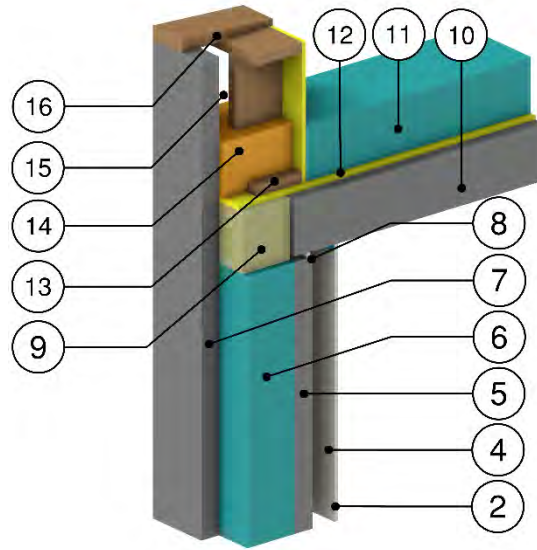

ID	Component	Thickness Inches (mm)	Conductivity Btu-in / ft ² ·hr·°F (W/m K)	Nominal Resistance hr·ft ² ·°F/Btu (m ² K/W)	Density lb/ft ³ (kg/m ³)	Specific Heat Btu/lb·°F (J/kg K)
1	Interior Film ¹	-	-	R-0.6 (0.11 RSI) to R-0.7 (0.12 RSI)	-	-
2	Gypsum Board	5/8" (15)	1.1 (0.16)	R-0.5 (0.09 RSI)	50 (800)	0.26 (1090)
3	3 5/8" x 1 5/8" Steel Studs with Top and Bottom Tracks	18 Gauge	430 (62)	-	489 (7830)	0.12 (500)
4	Air in Stud Cavity	3 5/8" (92)	-	R-0.9 (0.16 RSI)	0.075 (1.2)	0.24 (1000)
5	Precast Sandwich Panel, Interior Concrete Panel	3" (76)	12.5 (1.8)	-	140 (2250)	0.20 (850)
6	Precast Sandwich Panel Insulation	8" (203)	-	R-40 (7.04 RSI) to R-56 (9.86 RSI)	1.8 (28)	0.29 (1220)
7	Precast Sandwich Panel, Exterior Concrete Panel	3" (76)	12.5 (1.8)	-	140 (2250)	0.20 (850)
8	Sealant	-	1.73 (0.25)	-	-	-
9	Mineral Wool Slab Insulation	8" (203)	0.238 (0.034)	R-33.6 (5.92 RSI)	4 (64)	0.20 (850)
10	Concrete Roof Slab	8" (203)	12.5 (1.8)	-	140 (2250)	0.20 (850)
11	Roof Insulation	8" (203)	0.167 (0.024)	R-48 (8.45 RSI)	1.8 (28)	0.29 (1220)
12	Exterior Gypsum	5/8" (15)	12.5 (1.8)	-	140 (2250)	0.20 (850)
13	2x8 Wood Stud (16" o.c.)	7 1/4" (184)	0.69 (0.1)	-	31 (500)	0.45 (1880)
14	Spray Foam Insulation in Parapet Cavity	8" (203)	0.167 (0.024)	-	2.4 (39)	0.35 (1470)
15	Air in Parapet Cavity	12" (305)	-	R-0.9 (0.16 RSI)	0.075 (1.2)	0.24 (1000)
16	Wood Cap	1" (25)	0.69 (0.1)	-	31 (500)	0.45 (1880)
17	Exterior Film ¹	-	-	R-0.2 (0.03 RSI)	-	-

¹ Value selected from table 1, p. 26.1 of 2009 ASHRAE Handbook – Fundamentals depending on surface orientation



Detail 7.5.11

Owens Corning Exterior Insulated Concrete Block Wall Assembly with Heckmann Pos-I-Tie Veneer Anchoring System Supporting Brick Veneer – Parapet & Roof Intersection with Uninsulated Parapet

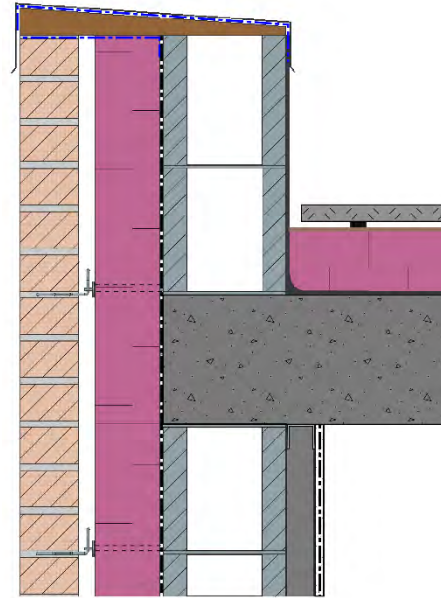
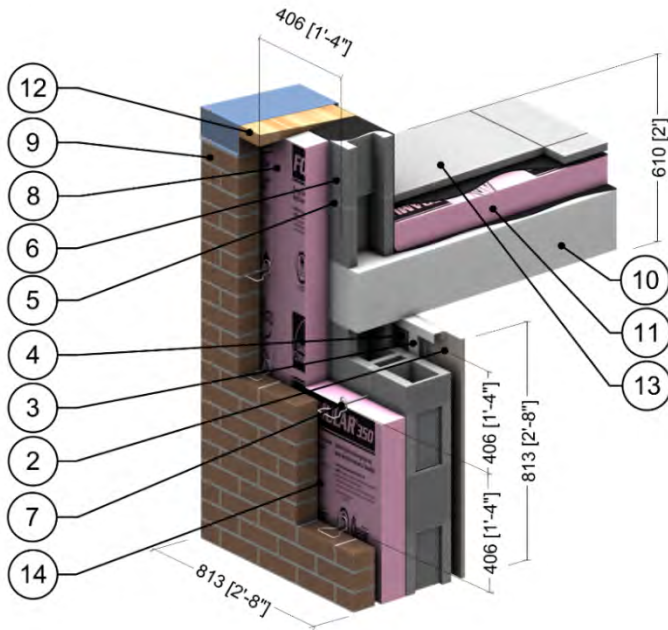

ID	Component	Thickness Inches (mm)	Conductivity Btu-in / ft ² -hr-°F (W/m K)	Nominal Resistance hr-ft ² -°F/Btu (m ² K/W)	Density lb/ft ³ (kg/m ³)	Specific Heat Btu/lb-°F (J/kg K)
1	Interior Film ¹	-	-	R-0.6 to R-0.7 (0.11 RSI to 0.12 RSI)	-	-
2	Gypsum Board	1/2" (13)	1.1 (0.16)	R-0.5 (0.08 RSI)	50 (800)	0.26 (1090)
3	1 5/8" Steel Studs with Metal Tracks	20 gauge	430 (62)	-	489 (7830)	0.12 (500)
4	Air in Stud Cavity	1 5/8" (41)	-	R-0.9 (0.16 RSI)	0.075 (1.2)	0.24 (1000)
5	Standard Concrete Block	7 5/8" (190)	3.5 (0.5)	-	119 (1900)	0.19 (800)
6	Cement Mortar	-	3.5 (0.5)	-	113 (1800)	0.12 (500)
7	Heckmann Pos-I-Tie Masonry Tie @ 16" (406) o.c.	varies	-	-	-	-
8	Foamular CodeBord/C-200 Extruded Polystyrene (XPS) Rigid Insulation Type 3	varies	0.20 (0.029)	R-10 to R-20 (1.76 to 3.52 RSI)	1.8 (28)	0.29 (1220)
9	Brick Veneer	3 5/8" (92)	5.4 (0.78)	-	120 (1920)	0.19 (720)
10	Concrete Slab	8" (203)	12.5 (1.8)	-	140 (2250)	0.20 (850)
11	Foamular XPS Rigid Insulation	4" (102)	0.20 (0.029)	R-20 (3.52 RSI)	1.8 (28)	0.29 (1220)
12	Wood Blocking	5/8" (16)	0.69 (0.10)	R-1.0 (0.18 RSI)	31 (500)	0.45 (1880)
13	Flashing & roof finish materials are incorporated into exterior heat transfer coefficient					
14	Air Gap	1" (25)	-	R-0.9 (0.16 RSI)	0.075 (1.2)	0.24 (1000)
15	Exterior Film ¹	-	-	R-0.2 to R-0.7 (0.03 RSI to 0.12 RSI)	-	-

¹ Value selected from table 1, p. 26.1 of 2009 ASHRAE Handbook – Fundamentals depending on surface orientation

Detail 7.5.12

Owens Corning Exterior Insulated Concrete Block Wall Assembly with Heckmann Pos-I-Tie Veneer Anchoring System Supporting Brick Veneer – Parapet & Roof Intersection with Insulation Wrapped Around Parapet

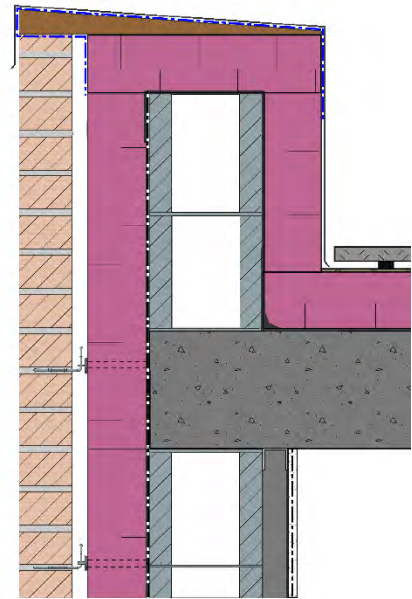
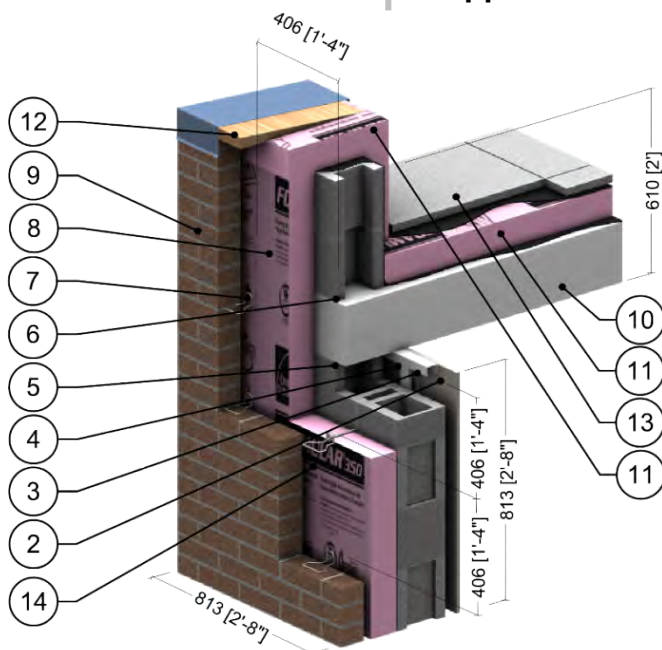

ID	Component	Thickness Inches (mm)	Conductivity Btu-in / ft ² -hr-°F (W/m K)	Nominal Resistance hr-ft ² -°F/Btu (m ² K/W)	Density lb/ft ³ (kg/m ³)	Specific Heat Btu/lb-°F (J/kg K)
1	Interior Film ¹	-	-	R-0.6 to R-0.7 (0.11 RSI to 0.12 RSI)	-	-
2	Gypsum Board	1/2" (13)	1.1 (0.16)	R-0.5 (0.08 RSI)	50 (800)	0.26 (1090)
3	1 5/8" Steel Studs with Metal Tracks	20 gauge	430 (62)	-	489 (7830)	0.12 (500)
4	Air in Stud Cavity	1 5/8" (41)	-	R-0.9 (0.16 RSI)	0.075 (1.2)	0.24 (1000)
5	Standard Concrete Block	7 5/8" (190)	3.5 (0.5)	-	119 (1900)	0.19 (800)
6	Cement Mortar	-	3.5 (0.5)	-	113 (1800)	0.12 (500)
7	Heckmann Pos-I-Tie Masonry Tie @ 16" (406) o.c.	varies	-	-	-	-
8	Foamular CodeBord/C-200 Extruded Polystyrene (XPS) Rigid Insulation Type 3	varies	0.20 (0.029)	R-10 to R-20 (1.76 to 3.52 RSI)	1.8 (28)	0.29 (1220)
9	Brick Veneer	3 5/8" (92)	5.4 (0.78)	-	120 (1920)	0.19 (720)
10	Concrete Slab	8" (203)	12.5 (1.8)	-	140 (2250)	0.20 (850)
11	Foamular XPS Rigid Insulation	4" (102)	0.20 (0.029)	R-20 (3.52 RSI)	1.8 (28)	0.29 (1220)
12	Wood Blocking	5/8" (16)	0.69 (0.10)	R-1.0 (0.18 RSI)	31 (500)	0.45 (1880)
13	Flashing & roof finish materials are incorporated into exterior heat transfer coefficient					
14	Air Gap	1" (25)	-	R-0.9 (0.16 RSI)	0.075 (1.2)	0.24 (1000)
15	Exterior Film ¹	-	-	R-0.2 to R-0.7 (0.03 RSI to 0.12 RSI)	-	-

¹ Value selected from table 1, p. 26.1 of 2009 ASHRAE Handbook – Fundamentals depending on surface orientation

Detail 7.5.13

Window Wall System – Double Glazed Insulated Frame at Concrete Precast Panel Parapet & Roof Intersection

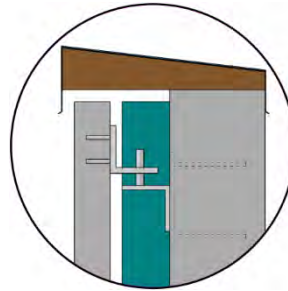
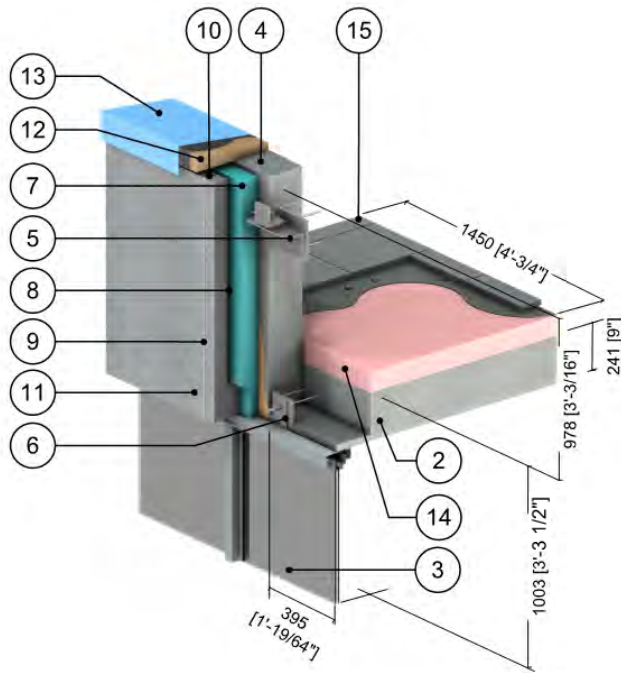

Stainless Steel Clip Mount: Bearing Connection Detail¹

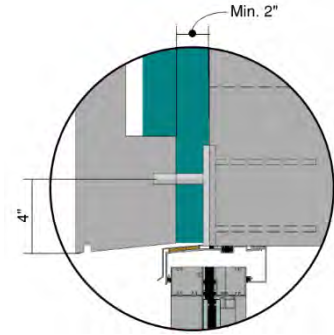

Stainless Steel Clip Mount: Lateral Connection Detail

ID	Component	Thickness Inches (mm)	Conductivity Btu-in / ft ² ·hr·°F (W/m K)	Nominal Resistance hr·ft ² ·°F/Btu (m ² K/W)	Density lb/ft ³ (kg/m ³)	Specific Heat Btu/lb·°F (J/kg K)
1	Interior Films ²	-	-	R-0.6 to R-1.1 (0.11 RSI to 0.20 RSI)	-	-
2	Concrete Slab	9 1/2" (241)	12.5 (1.8)	-	140 (2250)	0.20 (850)
3	Aluminum Window Wall Vision System: thermally broken frame ³ , no insulation in mullions, double glazed IGU U _{COG} = 0.32 BTU/hr·ft ² ·°F (1.82 W/m ² K)					
4	Parapet	8" (203)	12.5 (1.8)	-	140 (2250)	0.20 (850)
5	Stainless Steel Bearing Clip Mount	Varies	118 (17)	-	500 (8000)	0.12 (500)
6	Stainless Steel Lateral Clip Mount	Varies	118 (17)	-	500 (8000)	0.12 (500)
7	Parapet Rigid Insulation	Varies	0.20 (0.029)	R-10.0 to R-20.0 (1.76 RSI to 3.52 RSI)	1.8 (28)	0.29 (1220)
8	Vented Air Cavity	1" (25)	-	R-0.4 (0.07)	0.075 (1.2)	0.24 (1000)
9	Sealant	-	1.73 (0.25)	-	-	-
10	Backer Rod	-	0.25 (0.036)	-	-	-
11	Concrete Precast Panel	3" (76)	43 (6.2)	-	160 (2560)	0.21 (880)
12	Wood Blocking	5/8" (16)	0.69 (0.10)	R-1.0 (0.18 RSI)	31 (500)	0.45 (1880)
13	Cap Flashing	18 Gauge	430 (62)	-	489 (7830)	0.12 (500)
14	Roof Insulation	Varies	0.20 (0.029)	R-20 to R-40 (3.52 RSI to 7.04 RSI)	1.8 (28)	0.29 (1220)
15	Flashing & roof finish material are incorporated into exterior heat transfer coefficient					
16	Exterior Film ²	-	-	R-0.2 to R-0.7 (0.03 RSI to 0.12 RSI)	-	-

¹Cladding mounting hardware horizontal dimension varies equivalent to insulation thickness

² Value selected from table 1, p. 26.1 of 2009 ASHRAE Handbook – Fundamentals depending on surface orientation

³The thermal conductivity of air spaces within framing was found using ISO 100077-2

Detail 7.5.14

Window Wall System – Double Glazed Insulated Frame at Isokorb AXTI Thermally Broken Concrete Parapet & Roof Intersection

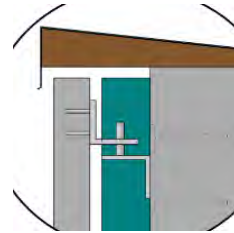
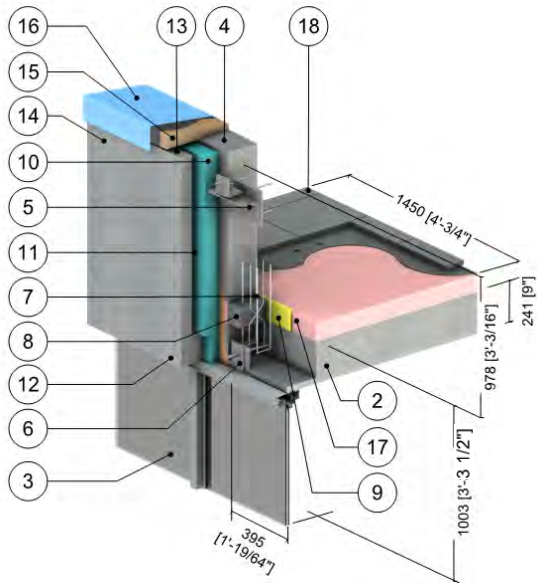

Stainless Steel Clip Mount:
Bearing Connection Detail¹

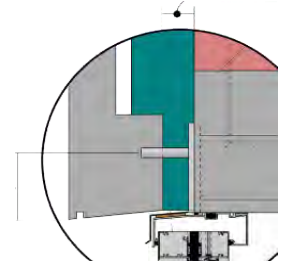

Stainless Steel Clip Mount:
Lateral Connection Detail

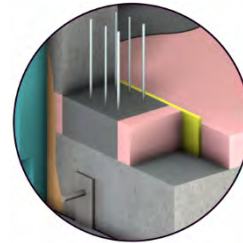

Roof Intersection with R-20 Roof
Insulation

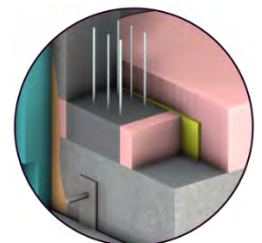

Roof Intersection with R-40 Roof
Insulation

ID	Component	Thickness Inches (mm)	Conductivity Btu-in / ft ² -hr-°F (W/m K)	Nominal Resistance hr-ft ² -°F/Btu (m ² K/W)	Density lb/ft ³ (kg/m ³)	Specific Heat Btu/lb-°F (J/kg K)
1	Interior Films ²	-	-	R-0.6 to R-1.1 (0.11 RSI to 0.20 RSI)	-	-
2	Concrete Slab	9 1/2" (241)	12.5 (1.8)	-	140 (2250)	0.20 (850)
3	Aluminum Window Wall Vision System: thermally broken frame ³ , no insulation in mullions, double glazed IGU U _{COG} = 0.32 BTU/hr-ft ² -°F (1.82 W/m ² K)					
4	Parapet	8" (203)	12.5 (1.8)	-	140 (2250)	0.20 (850)
5	Stainless Steel Bearing Clip Mount	Varies	118 (17)	-	500 (8000)	0.12 (500)
6	Stainless Steel Lateral Clip Mount	Varies	118 (17)	-	500 (8000)	0.12 (500)
7	Stainless Steel Rebar	-	118 (17)	-	500 (8000)	0.12 (500)
8	Polystyrene Rigid Foam Insulation	4 3/4" (120)	0.217 (0.031)	R-22.0 (3.87 RSI)	66 (1060)	0.35 (1500)
9	Exterior Sheathing	5/8" (16)	1.1 (0.16)	R-0.6 (0.10 RSI)	50 (800)	0.26 (1090)
10	Parapet Rigid Insulation	Varies	0.20 (0.029)	R-10.0 to R-20.0 (1.76 RSI to 3.52 RSI)	1.8 (28)	0.29 (1220)
11	Vented Air Cavity	1" (25)	-	R-0.4 (0.07)	0.075 (1.2)	0.24 (1000)
12	Sealant	-	1.73 (0.25)	-	-	-
13	Backer Rod	-	0.25 (0.036)	-	-	-
14	Concrete Precast Panel	3" (76)	43 (6.2)	-	160 (2560)	0.21 (880)
15	Wood Blocking	5/8" (16)	0.69 (0.10)	R-1.0 (0.18 RSI)	31 (500)	0.45 (1880)
16	Cap Flashing	18 Gauge	430 (62)	-	489 (7830)	0.12 (500)
17	Roof Insulation	Varies	0.20 (0.029)	R-20 to R-40 (3.52 RSI to 7.04 RSI)	1.8 (28)	0.29 (1220)
18	Flashing & roof finish material are incorporated into exterior heat transfer coefficient					
19	Exterior Film ²	-	-	R-0.2 to R-0.7 (0.03 RSI to 0.12 RSI)	-	-

¹ Cladding mounting hardware horizontal dimension varies equivalent to insulation thickness

² Value selected from table 1, p. 26.1 of 2009 ASHRAE Handbook – Fundamentals depending on surface orientation

³ The thermal conductivity of air spaces within framing was found using ISO 100077-2

Detail 7.5.15

Window Wall System – Triple Glazed Insulated Frame at Concrete Precast Panel Parapet & Roof Intersection

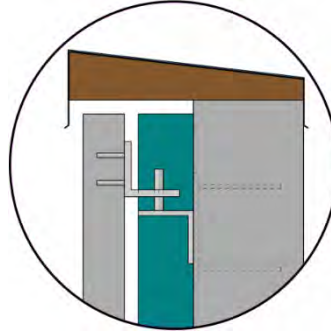
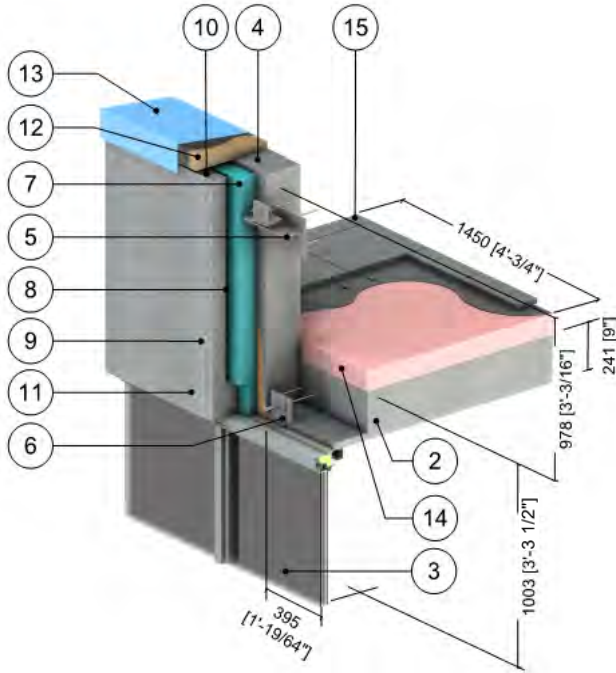

Stainless Steel Clip Mount: Bearing Connection Detail¹

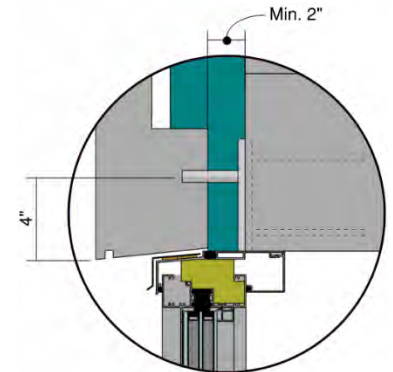

Stainless Steel Clip Mount: Lateral Connection Detail

ID	Component	Thickness Inches (mm)	Conductivity Btu-in / ft ² ·hr·°F (W/m K)	Nominal Resistance hr·ft ² ·°F/Btu (m ² K/W)	Density lb/ft ³ (kg/m ³)	Specific Heat Btu/lb·°F (J/kg K)
1	Interior Films ²	-	-	R-0.6 to R-1.1 (0.11 RSI to 0.20 RSI)	-	-
2	Concrete Slab	9 1/2" (241)	12.5 (1.8)	-	140 (2250)	0.20 (850)
3	Aluminum Window Wall Vision System: thermally broken frame with insulation in mullions ² , triple glazed IGU U _{COG} = 0.14 BTU/hr·ft ² ·°F (0.81 W/m ² K)					
4	Parapet	8" (203)	12.5 (1.8)	-	140 (2250)	0.20 (850)
5	Stainless Steel Bearing Clip Mount	Varies	118 (17)	-	500 (8000)	0.12 (500)
6	Stainless Steel Lateral Clip Mount	Varies	118 (17)	-	500 (8000)	0.12 (500)
7	Parapet Rigid Insulation	Varies	0.20 (0.029)	R-10.0 to R-20.0 (1.76 RSI to 3.52 RSI)	1.8 (28)	0.29 (1220)
8	Vented Air Cavity	1" (25)	-	R-0.4 (0.07)	0.075 (1.2)	0.24 (1000)
9	Sealant	-	1.73 (0.25)	-	-	-
10	Backer Rod	-	0.25 (0.036)	-	-	-
11	Concrete Precast Panel	3" (76)	43 (6.2)	-	160 (2560)	0.21 (880)
12	Wood Blocking	5/8" (16)	0.69 (0.10)	R-1.0 (0.18 RSI)	31 (500)	0.45 (1880)
13	Cap Flashing	18 Gauge	430 (62)	-	489 (7830)	0.12 (500)
14	Roof Insulation	Varies	0.20 (0.029)	R-20 to R-40 (3.52 RSI to 7.04 RSI)	1.8 (28)	0.29 (1220)
15	Flashing & roof finish material are incorporated into exterior heat transfer coefficient					
16	Exterior Film ²	-	-	R-0.2 to R-0.7 (0.03 RSI to 0.12 RSI)	-	-

¹Cladding mounting hardware horizontal dimension varies equivalent to insulation thickness

² Value selected from table 1, p. 26.1 of 2009 ASHRAE Handbook – Fundamentals depending on surface orientation

³The thermal conductivity of air spaces within framing was found using ISO 100077-2

Detail 7.5.16

Window Wall System – Triple Glazed Insulated Frame at Isokorb AXTI Thermally Broken Concrete Parapet & Roof Intersection

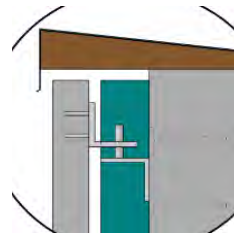
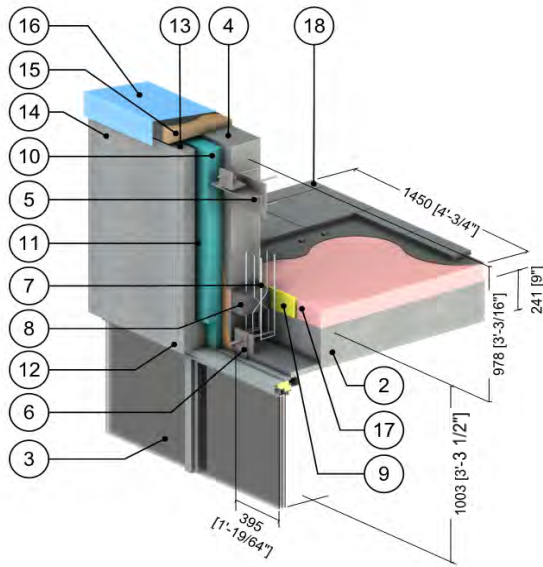

Stainless Steel Clip Mount:
Bearing Connection Detail¹

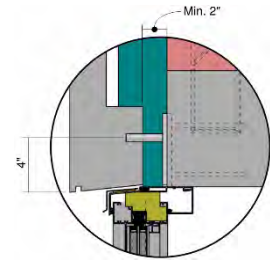

Stainless Steel Clip Mount:
Lateral Connection Detail

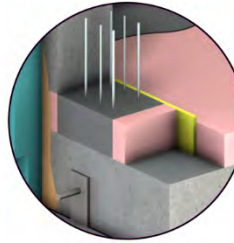

Roof Intersection with R-20 Roof
Insulation

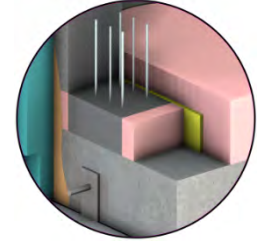

Roof Intersection with R-40 Roof
Insulation

ID	Component	Thickness Inches (mm)	Conductivity Btu-in / ft ² -hr-°F (W/m K)	Nominal Resistance hr-ft ² -°F/Btu (m ² K/W)	Density lb/ft ³ (kg/m ³)	Specific Heat Btu/lb-°F (J/kg K)
1	Interior Films ²	-	-	R-0.6 to R-1.1 (0.11 RSI to 0.20 RSI)	-	-
2	Concrete Slab	9 1/2" (241)	12.5 (1.8)	-	140 (2250)	0.20 (850)
3	Aluminum Window Wall Vision System: thermally broken frame with insulation in mullions ² , triple glazed IGU U _{COG} = 0.14 BTU/hr-ft ² -°F (0.81 W/m ² K)					
4	Parapet	8" (203)	12.5 (1.8)	-	140 (2250)	0.20 (850)
5	Stainless Steel Bearing Clip Mount	Varies	118 (17)	-	500 (8000)	0.12 (500)
6	Stainless Steel Lateral Clip Mount	Varies	118 (17)	-	500 (8000)	0.12 (500)
7	Stainless Steel Rebar	-	118 (17)	-	500 (8000)	0.12 (500)
8	Polystyrene Rigid Foam Insulation	4 3/4" (120)	0.217 (0.031)	R-22.0 (3.87 RSI)	66 (1060)	0.35 (1500)
9	Exterior Sheathing	5/8" (16)	1.1 (0.16)	R-0.6 (0.10 RSI)	50 (800)	0.26 (1090)
10	Parapet Rigid Insulation	Varies	0.20 (0.029)	R-10.0 to R-20.0 (1.76 RSI to 3.52 RSI)	1.8 (28)	0.29 (1220)
11	Vented Air Cavity	1" (25)	-	R-0.4 (0.07)	0.075 (1.2)	0.24 (1000)
12	Sealant	-	1.73 (0.25)	-	-	-
13	Backer Rod	-	0.25 (0.036)	-	-	-
14	Concrete Precast Panel	3" (76)	43 (6.2)	-	160 (2560)	0.21 (880)
15	Wood Blocking	5/8" (16)	0.69 (0.10)	R-1.0 (0.18 RSI)	31 (500)	0.45 (1880)
16	Cap Flashing	18 Gauge	430 (62)	-	489 (7830)	0.12 (500)
17	Roof Insulation	Varies	0.20 (0.029)	R-20 to R-40 (3.52 RSI to 7.04 RSI)	1.8 (28)	0.29 (1220)
18	Flashing & roof finish material are incorporated into exterior heat transfer coefficient					
19	Exterior Film ²	-	-	R-0.2 to R-0.7 (0.03 RSI to 0.12 RSI)	-	-

¹ Cladding mounting hardware horizontal dimension varies equivalent to insulation thickness

² Value selected from table 1, p. 26.1 of 2009 ASHRAE Handbook – Fundamentals depending on surface orientation

³ The thermal conductivity of air spaces within framing was found using ISO 100077-2



Detail 7.6.1

Exterior Insulated Concrete Drained EIFS Wall Assembly – Corner Intersection

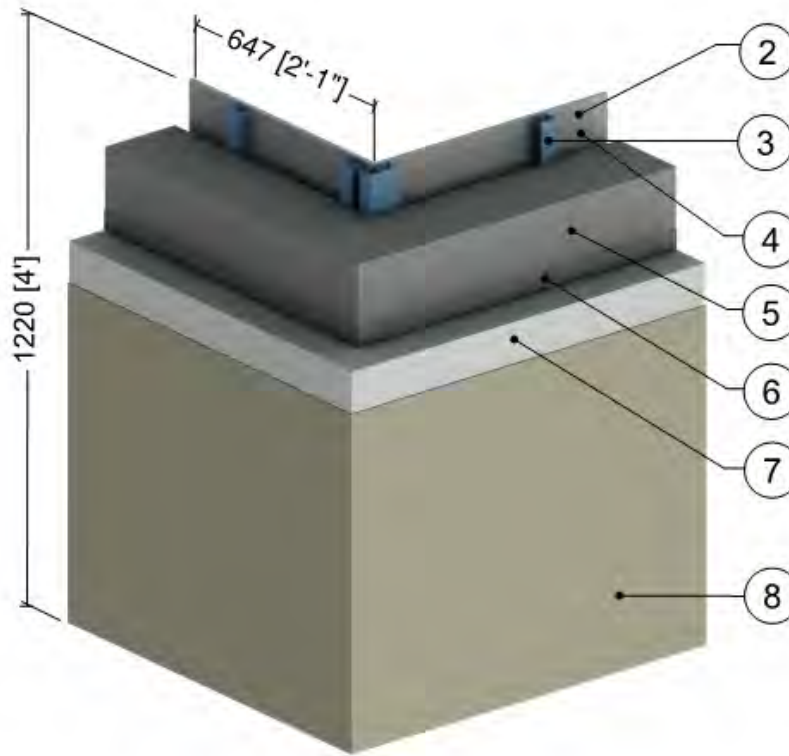

ID	Component	Thickness Inches (mm)	Conductivity Btu-in / ft ² -hr-°F (W/m K)	Nominal Resistance hr-ft ² -°F/Btu (m ² K/W)	Density lb/ft ³ (kg/m ³)	Specific Heat Btu/lb-°F (J/kg K)
1	Interior Films ¹	-	-	R-0.6 (0.11 RSI)	-	-
2	Gypsum Board	1/2" (13)	1.1 (0.16)	R-0.5 (0.08 RSI)	50 (800)	0.26 (1090)
3	1 5/8" x 1 5/8" Steel Studs (16"o.c.)	18 Gauge	430 (62)	-	489 (7830)	0.12 (500)
4	Air in Stud Cavity	1 5/8" (41)	-	R-0.9 (0.16 RSI)	0.075 (1.2)	0.24 (1000)
5	Concrete Wall	8" (203)	12.5 (1.8)	-	140 (2250)	0.20 (850)
6	Weather Resistive Barrier with Adhesive	-	-	-	-	-
7	Insulation Board	4" (100)	0.27 (0.039)	R-15 (2.64 RSI)	1 (16)	0.35 (1470)
8	Lamina	1/8" (4)	6 (0.9)	R-0.04 (0.01 RSI)	120 (1922)	0.20 (850)
9	Exterior Film ¹	-	-	R-0.2 (0.03 RSI)	-	-

¹ Value selected from table 1, p. 26.1 of 2009 ASHRAE Handbook – Fundamentals depending on surface orientation

Detail 7.6.2

Highly Insulated Precast Concrete Sandwich Panel Wall Assembly – Outside Corner

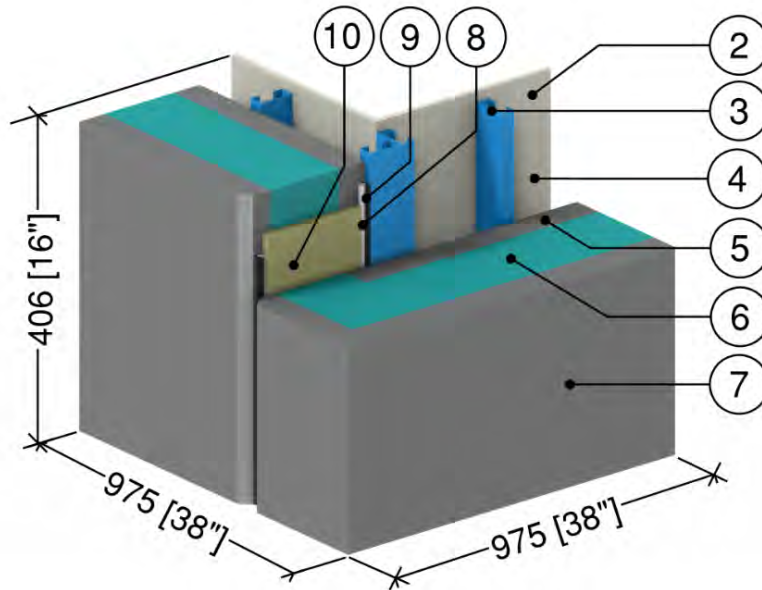

ID	Component	Thickness Inches (mm)	Conductivity Btu-in / ft ² -hr-°F (W/m K)	Nominal Resistance hr-ft ² -°F/Btu (m ² K/W)	Density lb/ft ³ (kg/m ³)	Specific Heat Btu/lb-°F (J/kg K)
1	Interior Film ¹	-	-	R-0.7 (0.12 RSI)	-	-
2	Gypsum Board	5/8" (15)	1.1 (0.16)	R-0.5 (0.09 RSI)	50 (800)	0.26 (1090)
3	3 5/8" x 1 5/8" Steel Studs with Top and Bottom Tracks	18 Gauge	430 (62)	-	489 (7830)	0.12 (500)
4	Air in Stud Cavity	3 5/8" (92)	-	R-0.9 (0.16 RSI)	0.075 (1.2)	0.24 (1000)
5	Precast Sandwich Panel, Interior Concrete Panel	3" (76)	12.5 (1.8)	-	140 (2250)	0.20 (850)
6	Precast Sandwich Panel Insulation	8" (203)	-	R-40 (7.04 RSI) to R-56 (9.86 RSI)	1.8 (28)	0.29 (1220)
7	Precast Sandwich Panel, Exterior Concrete Panel	3" (76)	12.5 (1.8)	-	140 (2250)	0.20 (850)
8	Sealant	-	1.73 (0.25)	-	-	-
9	Backer Rod	-	0.25 (0.036)	-	-	-
10	Mineral Wool Insulation	-	0.238 (0.034)	-	4 (64)	0.20 (850)
11	Exterior Film ¹	-	-	R-0.2 (0.03 RSI)	-	-

¹ Value selected from table 1, p. 26.1 of 2009 ASHRAE Handbook – Fundamentals depending on surface orientation

Detail 7.7.1

Interior Insulated Concrete Mass Wall with 3 5/8" x 1 5/8" Steel Studs (16" o.c.) Supporting Interior Finish – Intermediate Floor Intersection above Parking Garage

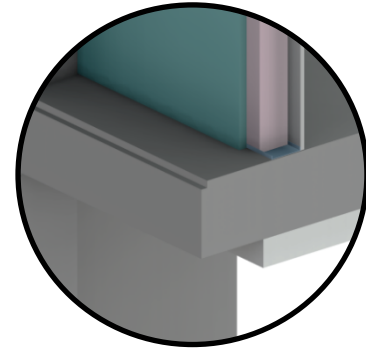
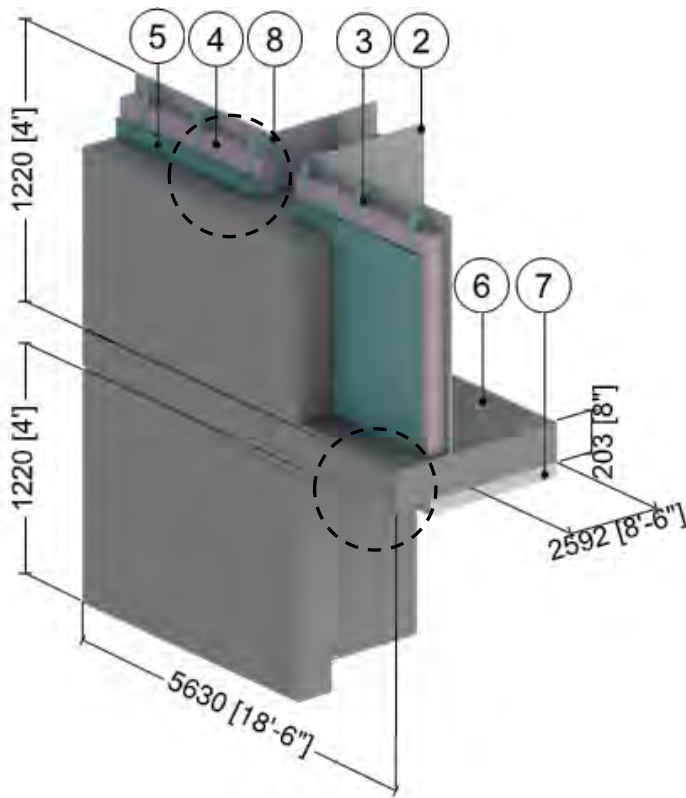

Slab Edge Detail

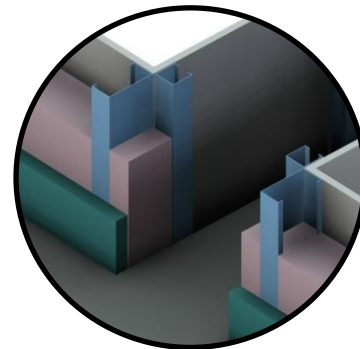

Partition Detail

ID	Component	Thickness Inches (mm)	Conductivity Btu-in / ft ² -hr-°F (W/m K)	Nominal Resistance hr-ft ² -°F/Btu (m ² K/W)	Density lb/ft ³ (kg/m ³)	Specific Heat Btu/lb-°F (J/kg K)
1	Interior Film ¹	-	-	R-0.6 to R-0.9 (0.11 RSI to 0.16 RSI)	-	-
2	Gypsum Board	1/2" (13)	1.1 (0.16)	R-0.5 (0.08 RSI)	50 (800)	0.26 (1090)
3	3 5/8" x 1 5/8" Steel Studs with Bottom Tracks	18 Gauge	430 (62)	-	489 (7830)	0.12 (500)
4	Fiberglass Batt Insulation	3 5/8" (92)	0.29 (0.042)	R-12 (2.1 RSI)	0.9 (14)	0.17 (710)
5	Continuous Insulation	Varies	-	R-10 to R-15 (1.76 RS to 2.64 RSI)	1.8 (28)	0.29 (1220)
6	Concrete Wall & Floor Slab	8" (203)	12.5 (1.8)	-	140 (2250)	0.20 (850)
7	Spray Applied Fiberglass Insulation	4" (102)	0.20 (0.029)	R-20 (3.5 RSI)	0.9 (14)	0.12 (500)
8	1 5/8" x 1 5/8" Steel Studs with Bottom Tracks	18 Gauge	430 (62)	-	489 (7830)	0.12 (500)
9	Exterior Film ¹	-	-	R-0.2 (0.03 RSI)	-	-

¹ Value selected from table 1, p. 26.1 of 2009 ASHRAE Handbook – Fundamentals depending on surface orientation

Detail 7.7.2

Insulated Concrete Floor Slab – Concrete Column Intersection

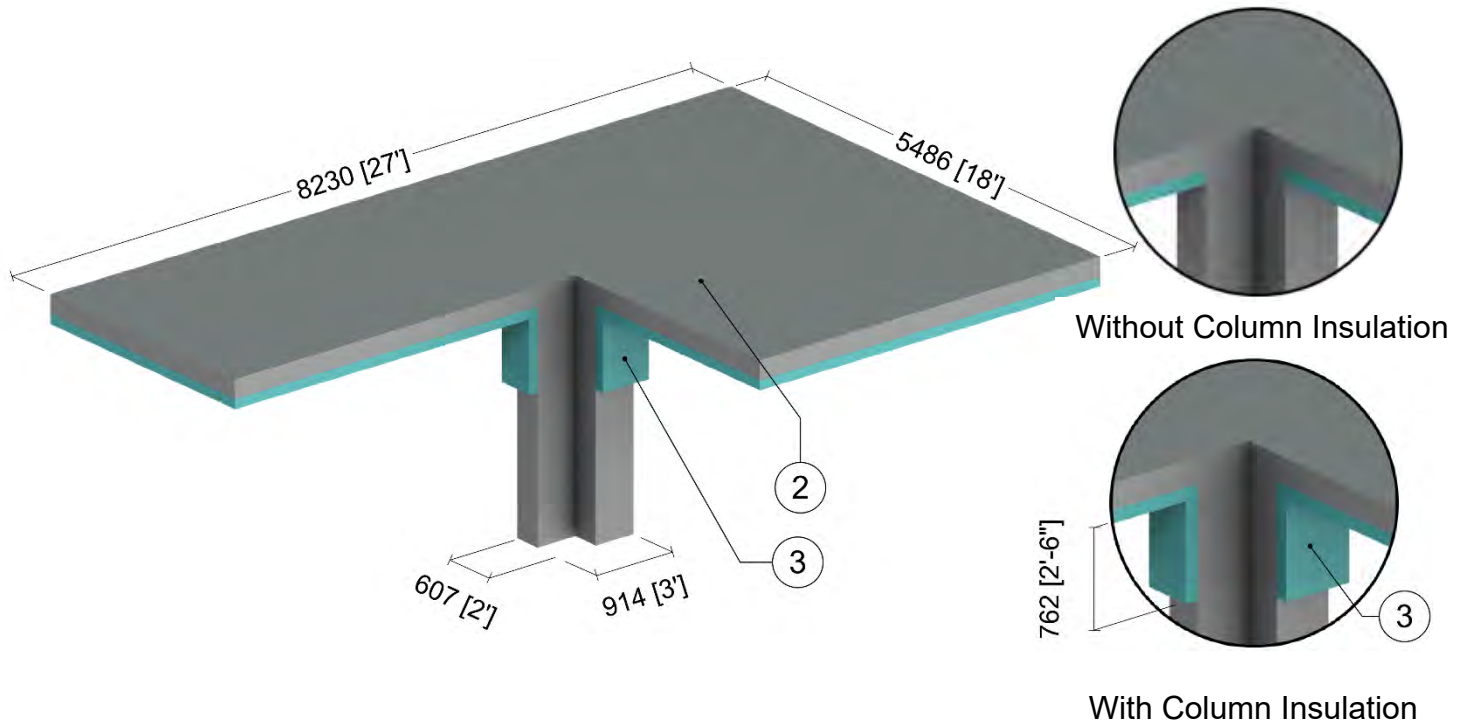

ID	Component	Thickness Inches (mm)	Conductivity Btu·in / ft ² ·hr·°F (W/m K)	Nominal Resistance hr·ft ² ·°F/Btu (m ² K/W)	Density lb/ft ³ (kg/m ³)	Specific Heat Btu/lb·°F (J/kg K)
1	Interior Films ¹	-	-	R-0.9 (0.16 RSI)	-	-
2	Concrete Floor	8" (203)	12.5 (1.8)	-	140 (2250)	0.20 (850)
3	Spray Applied Fiberglass Insulation	4" (101)	0.2 (0.029)	R-20 (3.5 RSI)	0.9 (14)	0.12 (500)
4	Exterior Film ¹	-	-	R-0.6 (0.11 RSI)	-	-

¹ Value selected from table 1, p. 26.1 of 2009 ASHRAE Handbook – Fundamentals depending on surface orientation

Detail 7.7.3

Precast Sandwich Wall Assembly Slab and Foundation Intersection

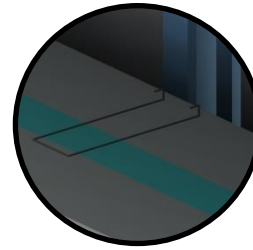
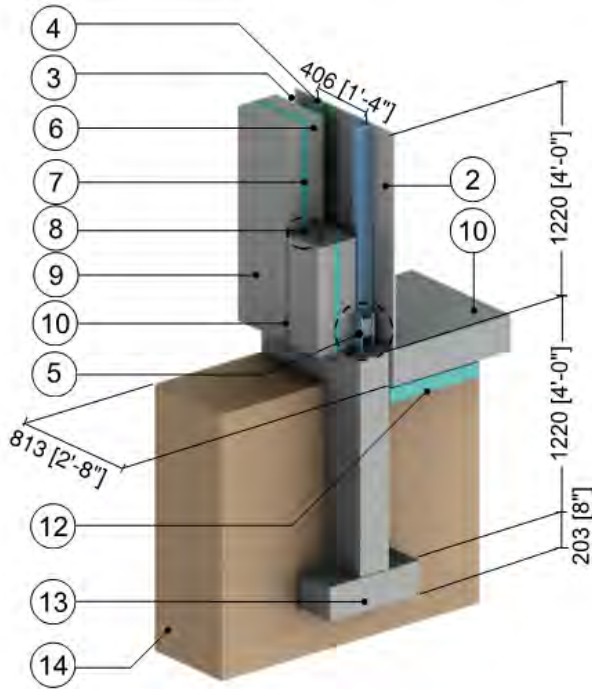

Connector Detail

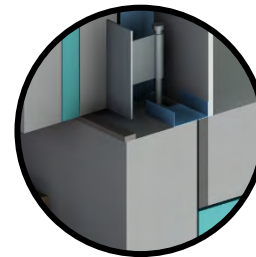

Gravity and Slot Anchor Detail

ID	Component	Thickness Inches (mm)	Conductivity Btu-in / ft ² -hr-°F (W/m K)	Nominal Resistance hr-ft ² -°F/Btu (m ² K/W)	Density lb/ft ³ (kg/m ³)	Specific Heat Btu/lb-°F (J/kg K)
1	Interior Film ¹	-	-	R-0.7 to R-0.9 (0.12 RSI to 0.16 RSI)	-	-
2	Gypsum Board	1/2" (13)	1.1 (0.16)	R-0.5 (0.08 RSI)	50 (800)	0.26 (1090)
3	Air in Stud Cavity	5" (127)	-	R-0.9 (0.16 RSI)	0.075 (1.2)	0.24 (1000)
4	3 5/8" Steel Studs with Bottom Tracks	18 Gauge	430 (62)	-	489 (7830)	0.12 (500)
5	Gravity and Slot Anchors at Slab	-	347 (50)	-	489 (7830)	0.12 (500)
6	Precast Sandwich Panel, Interior Concrete	4" (102)	12.5 (1.8)	-	140 (2250)	0.20 (850)
7	Precast Sandwich Panel, Insulation	2" (51)	-	R-10 (1.76 RSI)	1.8 (28)	0.29 (1220)
8	Precast Sandwich Panel, Structural Ties @ 24" (610) o.c.	16 Gauge	430 (62)	-	489 (7830)	0.12 (500)
9	Precast Sandwich Panel, Exterior Concrete	4" (102)	12.5 (1.8)	-	140 (2250)	0.20 (850)
10	Silicone Sealant	-	2.4 (3.5)	-	174 (2800)	0.17 (700)
11	Concrete Slab on Grade	8" (203)	12.5 (1.8)	-	140 (2250)	0.20 (850)
12	Foundation Insulation	3 1/2" (89)	0.24 (0.0343)	R-15 (2.6 RSI)	1.8 (28)	0.29 (1220)
13	Concrete Footing	12" (305)	12.5 (1.8)	-	140 (2250)	0.20 (850)
14	Soil	-	15.6 (2.25)	-	-	-
15	Exterior Film ¹	-	-	R-0.2 (0.03 RSI)	-	-

¹ Value selected from table 1, p. 26.1 of 2009 ASHRAE Handbook – Fundamentals depending on surface orientation

Detail 7.7.4

Precast Sandwich Panel with 3 5/8" Steel Stud (16" o.c.) – Concrete Slab and Foundation Wall

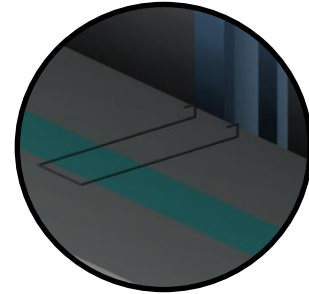
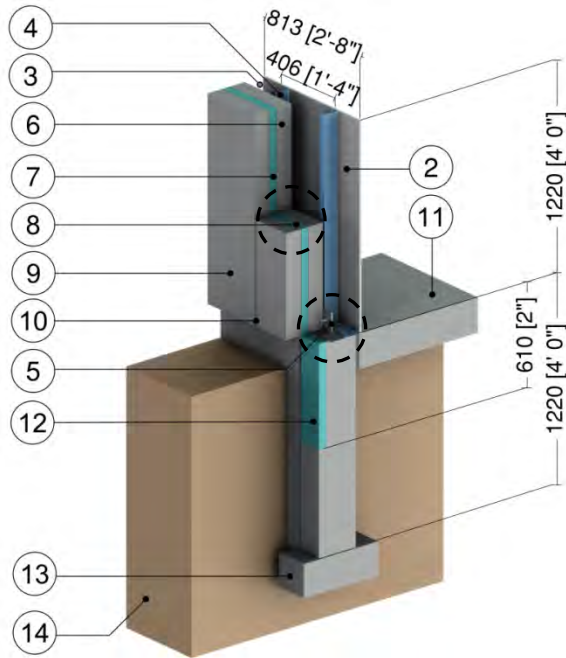

Connector Detail

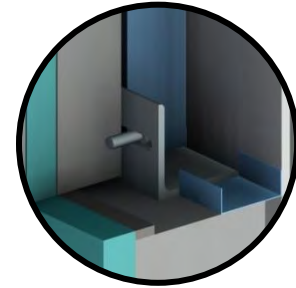

Gravity and Slot Anchor Detail

ID	Component	Thickness Inches (mm)	Conductivity Btu-in / ft ² -hr-°F (W/m K)	Nominal Resistance hr-ft ² -°F/Btu (m ² K/W)	Density lb/ft ³ (kg/m ³)	Specific Heat Btu/lb-°F (J/kg K)
1	Interior Film ¹	-	-	R-0.7 to R-0.9 (0.12 RSI to 0.16 RSI)	-	-
2	Gypsum Board	1/2" (13)	1.1 (0.16)	R-0.5 (0.08 RSI)	50 (800)	0.26 (1090)
3	Air in Stud Cavity	5 5/8" (143)	-	R-0.9 (0.16 RSI)	0.075 (1.2)	0.24 (1000)
4	3 5/8" Steel Studs with Top and Bottom Tracks	18 Gauge	430 (62)	-	489 (7830)	0.12 (500)
5	Gravity and Slot Anchors at Slab	-	347 (50)	-	489 (7830)	0.12 (500)
6	Precast Sandwich Panel, Interior Concrete	4" (102)	12.5 (1.8)	-	140 (2250)	0.20 (850)
7	Precast Sandwich Panel, Insulation	2" (51)	-	R-10 (1.76 RSI)	1.8 (28)	0.29 (1220)
8	Precast Sandwich Panel, Structural Ties @ 24" o.c.	16 Gauge	430 (62)	-	489 (7830)	0.12 (500)
9	Precast Sandwich Panel, Exterior Concrete	4" (102)	12.5 (1.8)	-	140 (2250)	0.20 (850)
10	Silicone Sealant	-	2.4 (3.5)	-	174 (2800)	0.17 (700)
11	Concrete Slab on Grade	8" (203)	12.5 (1.8)	-	140 (2250)	0.20 (850)
12	Foundation Insulation	2" (50)	0.2 (0.028)	R-10 (1.76 RSI)	1.8 (28)	0.29 (1220)
13	Concrete Footing	8" (203)	12.5 (1.8)	-	140 (2250)	0.20 (850)
14	Soil	-	15.6 (2.25)	-	-	-
15	Exterior Film ¹	-	-	R-0.2 (0.03 RSI)	-	-

¹ Value selected from table 1, p. 26.1 of 2009 ASHRAE Handbook – Fundamentals depending on surface orientation

Detail 7.7.5

Precast Sandwich Panel with 3 5/8" Steel Stud (16" o.c.) – Thermally Broken Concrete Slab and Foundation Intersection

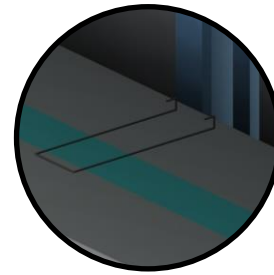
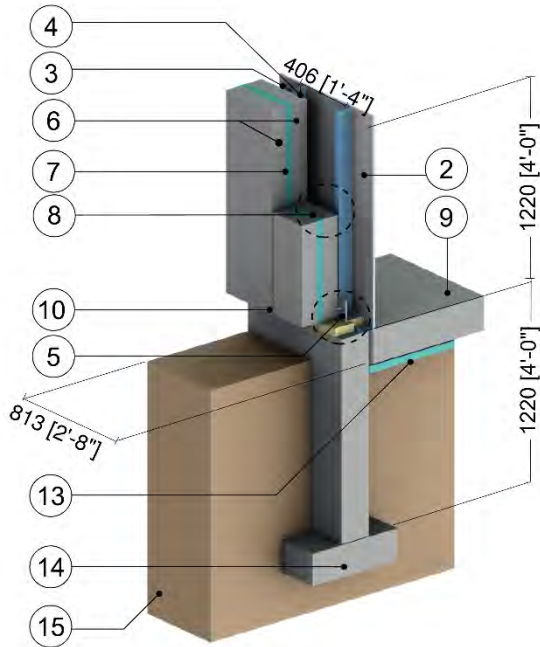

Connector Detail

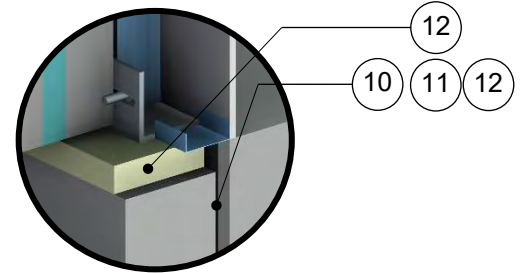

Gravity and Slot Anchor Detail

ID	Component	Thickness Inches (mm)	Conductivity Btu-in / ft ² ·hr·°F (W/m K)	Nominal Resistance hr·ft ² ·°F/Btu (m ² K/W)	Density lb/ft ³ (kg/m ³)	Specific Heat Btu/lb·°F (J/kg K)
1	Interior Film ¹	-	-	R-0.7 to R-0.9 (0.12 RSI to 0.16 RSI)	-	-
2	Gypsum Board	1/2" (13)	1.1 (0.16)	R-0.5 (0.08 RSI)	50 (800)	0.26 (1090)
3	Air in Stud Cavity	5" (127)	-	R-0.9 (0.16 RSI)	0.075 (1.2)	0.24 (1000)
4	3 5/8" Steel Studs with Top and Bottom Tracks	18 Gauge	430 (62)	-	489 (7830)	0.12 (500)
5	Gravity and Slot Anchors at Slab	-	347 (50)	-	489 (7830)	0.12 (500)
6	Precast Sandwich Panels	4" (102)	12.5 (1.8)	-	140 (2250)	0.20 (850)
7	Precast Sandwich Panel, Insulation	2" (51)	-	R-10 (1.76 RSI)	1.8 (28)	0.29 (1220)
8	Precast Sandwich Panel, Structural Ties @ 24" (610) o.c.	16 Gauge	430 (62)	-	489 (7830)	0.12 (500)
9	Concrete Slab on Grade	8" (203)	12.5 (1.8)	-	140 (2250)	0.20 (850)
10	Sealant	-	2.4 (3.5)	-	174 (2800)	0.17 (700)
11	Fibreboard	1" (25)	0.38 (0.055)	R-2.6 (0.47 RSI)	16 (254)	0.50 (2100)
12	Armatherm 500	2" (50)	0.32 (0.05)	R-6.2 (1.09 RSI)	-	-
13	Foundation Insulation	3 1/2" (89)	0.24 (0.0343)	R-15 (2.6 RSI)	1.8 (28)	0.29 (1220)
14	Concrete Footing	12" (305)	12.5 (1.8)	-	140 (2250)	0.20 (850)
15	Soil	-	15.6 (2.25)	-	-	-
16	Exterior Film ¹	-	-	R-0.2 (0.03 RSI)	-	-

¹ Value selected from table 1, p. 26.1 of 2009 ASHRAE Handbook – Fundamentals depending on surface orientation

Detail 7.7.6

Insulated Slab on Grade – Steel Column

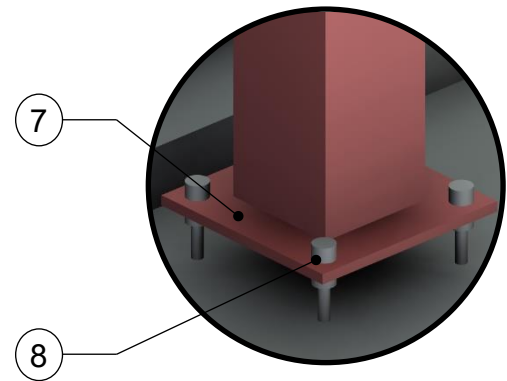
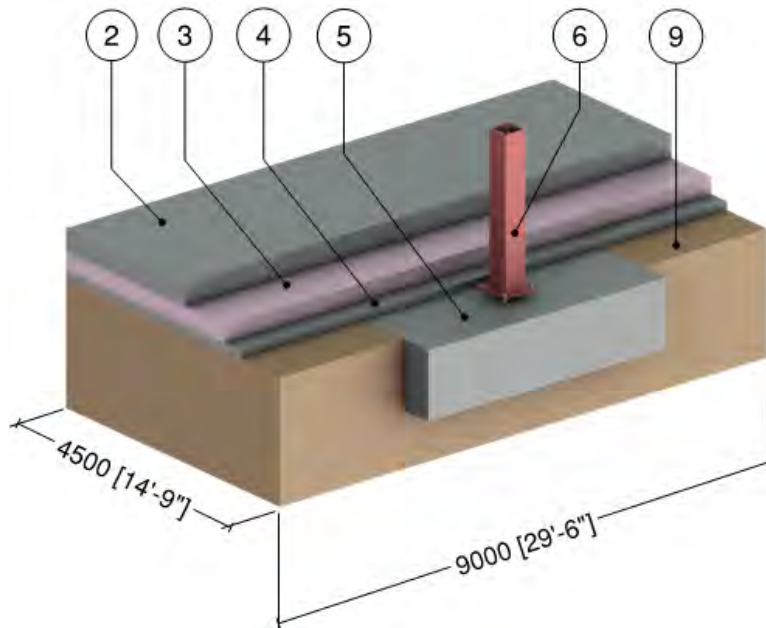

Column Connection

ID	Component	Thickness Inches (mm)	Conductivity Btu-in / ft ² ·hr·°F (W/m K)	Nominal Resistance hr·ft ² ·°F/Btu (m ² K/W)	Density lb/ft ³ (kg/m ³)	Specific Heat Btu/lb·°F (J/kg K)
1	Interior Film ¹	-	-	R-0.7 to R-0.9 (0.12 RSI to 0.16 RSI)	-	-
2	Concrete Slab on Grade	8" (203)	12.5 (1.8)	-	140 (2250)	0.20 (850)
3	Extruded Polystyrene Insulation (XPS)	6" (152)	0.20 (0.029)	R-30 (5.28 RSI)	1.8 (28)	0.29 (1220)
4	Concrete Sub Slab	3" (76)	12.5 (1.8)	-	140 (2250)	0.20 (850)
5	Concrete Footing	24" (610)	12.5 (1.8)	-	140 (2250)	0.20 (850)
6	8" x 8" HSS Column	3/8" (10)	347 (50)	-	489 (7830)	0.12 (500)
7	14" x 14" x 1/2" Base Plate	1/2" (13)	430 (62)	-	489 (7830)	0.12 (500)
8	Stainless Steel Bolts	3/4" (6) ∅	117 (17)	-	489 (7830)	0.12 (500)
9	Soil	-	10.4 (1.5)	-	-	-

¹ Value selected from table 1, p. 26.1 of 2009 ASHRAE Handbook – Fundamentals depending on surface orientation

Detail 7.7.7

Insulated Slab on Grade – Armatherm 500 Thermal Break under Column

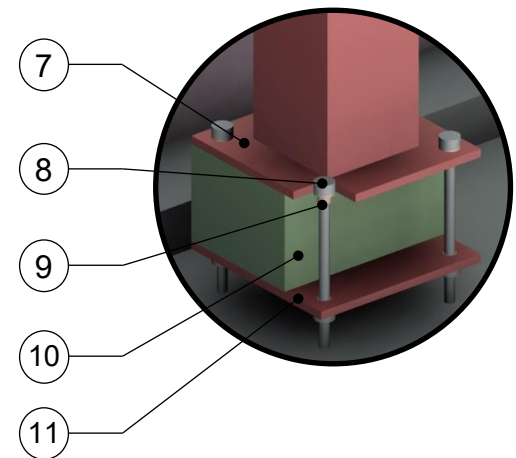
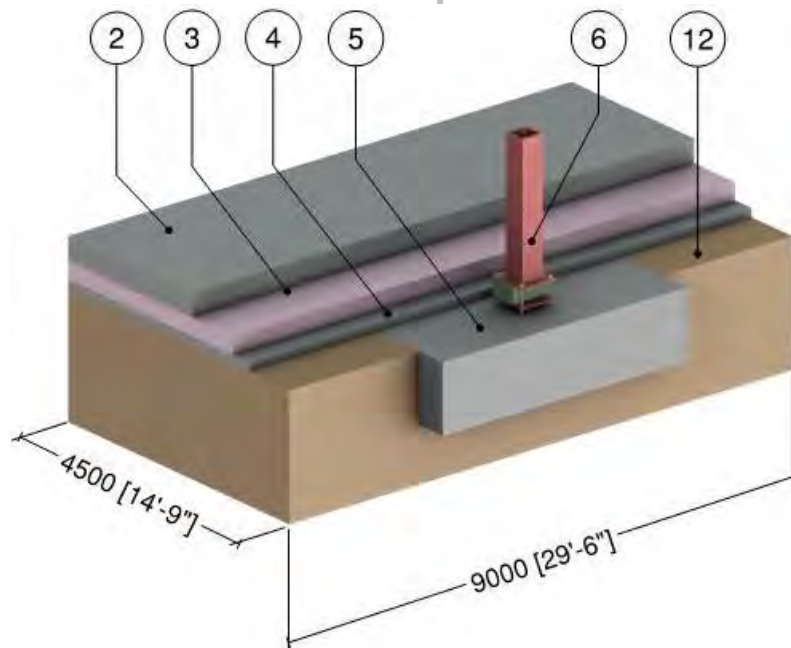

Armatherm 500 Column
Thermal Break

ID	Component	Thickness Inches (mm)	Conductivity Btu-in / ft ² ·hr·°F (W/m K)	Nominal Resistance hr·ft ² ·°F/Btu (m ² K/W)	Density lb/ft ³ (kg/m ³)	Specific Heat Btu/lb·°F (J/kg K)
1	Interior Film ¹	-	-	R-0.7 (0.12 RSI)	-	-
2	Concrete Slab on Grade	8" (203)	12.5 (1.8)	-	140 (2250)	0.20 (850)
3	Extruded Polystyrene Insulation (XPS)	6" (152)	0.20 (0.029)	R-30 (5.28 RSI)	1.8 (28)	0.29 (1220)
4	Concrete Sub Slab	3" (76)	12.5 (1.8)	-	140 (2250)	0.20 (850)
5	Concrete Footing	24" (610)	12.5 (1.8)	-	140 (2250)	0.20 (850)
6	8" x 8" HSS Column	3/8" (10)	347 (50)	-	489 (7830)	0.12 (500)
7	14" x 14" x 1/2" Base Plate	1/2" (13)	430 (62)	-	489 (7830)	0.12 (500)
8	Stainless Steel Bolts	3/4" (6) ϕ	117 (17)	-	489 (7830)	0.12 (500)
9	Armatherm FRR Washers and Bushing	-	1.4 (0.2)	-	85 (1362)	-
10	Armatherm 500 Thermal Break	6" (152)	0.32 (0.05)	-	-	-
11	14" x 14" x 1/2" Base Plate	1/2" (13)	430 (62)	-	489 (7830)	0.12 (500)
12	Soil	-	10.4 (1.5)	-	-	-

¹ Value selected from table 1, p. 26.1 of 2009 ASHRAE Handbook – Fundamentals depending on surface orientation

Detail 7.7.8

Highly Insulated Precast Concrete Sandwich Panel Wall Assembly – Base of Wall at Foundation with Insulation Skirt

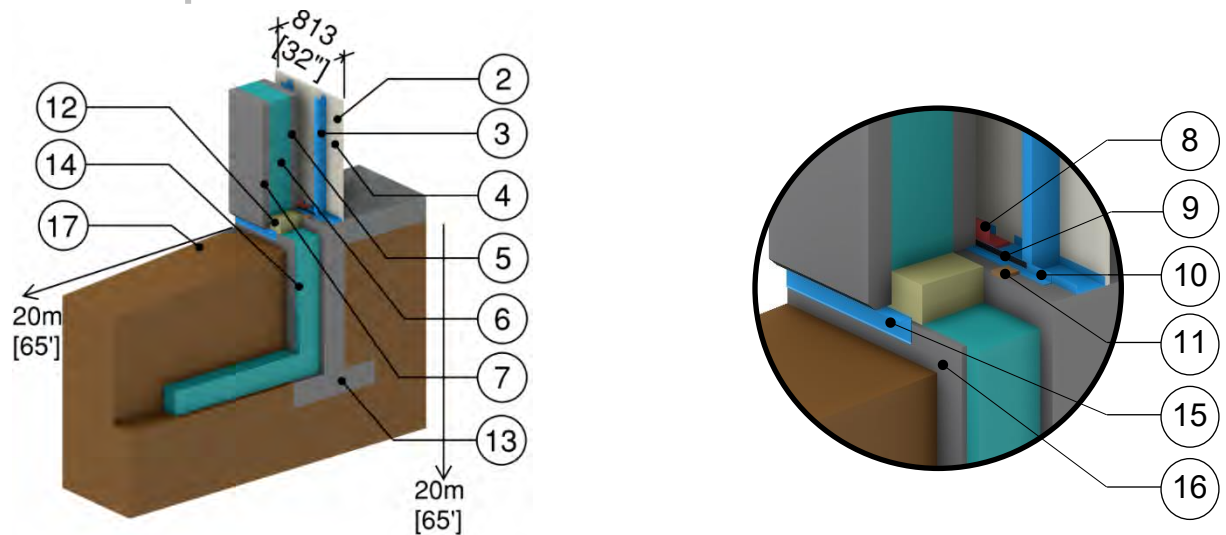

ID	Component	Thickness Inches (mm)	Conductivity Btu-in / ft ² -hr-°F (W/m K)	Nominal Resistance hr-ft ² -°F/Btu (m ² K/W)	Density lb/ft ³ (kg/m ³)	Specific Heat Btu/lb-°F (J/kg K)
1	Interior Film ¹	-	-	R-0.7 (0.12 RSI) to R-0.9 (0.16 RSI)	-	-
2	Gypsum Board	5/8" (15)	1.1 (0.16)	R-0.5 (0.09 RSI)	50 (800)	0.26 (1090)
3	3 5/8" x 1 5/8" Steel Studs with Top and Bottom Tracks	18 Gauge	430 (62)	-	489 (7830)	0.12 (500)
4	Air in Stud Cavity	3 5/8" (92)	-	R-0.9 (0.16 RSI)	0.075 (1.2)	0.24 (1000)
5	Precast Sandwich Panel, Interior Concrete Panel	3" (76)	12.5 (1.8)	-	140 (2250)	0.20 (850)
6	Precast Sandwich Panel Insulation	8" (203)	-	R-40 (7.04 RSI) to R-56 (9.86 RSI)	1.8 (28)	0.29 (1220)
7	Precast Sandwich Panel, Exterior Concrete Panel	3" (76)	12.5 (1.8)	-	140 (2250)	0.20 (850)
8	Anchor	-	347 (50)	-	489 (7830)	0.12 (500)
9	Sealant	-	1.73 (0.25)	-	-	-
10	Angle	-	430 (62)	-	489 (7830)	0.12 (500)
11	Shims	-	0.69 (0.1)	-	-	-
12	Mineral Wool Slab Insulation	8" (203)	0.238 (0.034)	R-33.6 (5.92 RSI)	4 (64)	0.20 (850)
13	Concrete Footing and Slab	8" (203)	12.5 (1.8)	-	140 (2250)	0.20 (850)
14	Foundation Insulation	8" (203)	0.167 (0.024)	R-48 (8.45 RSI)	1.8 (28)	0.29 (1220)
15	Flashing	18 Gauge	430 (62)	-	489 (7830)	0.12 (500)
16	Cover Board	5/8" (15)	12.5 (1.8)	-	140 (2250)	0.20 (850)
17	Soil	-	13.9 (2)	-	-	-
18	Exterior Film ¹	-	-	R-0.2 (0.03 RSI)	-	-

¹ Value selected from table 1, p. 26.1 of 2009 ASHRAE Handbook – Fundamentals depending on surface orientation

Detail 7.7.9

Owens Corning Exterior Insulated Concrete Block Wall Assembly with Steel Shelf Angle and Heckmann Pos-I-Tie Vener Anchoring System Supporting Brick Veneer and Insulation Below Floor – Slab on Grade and Foundation Intersection

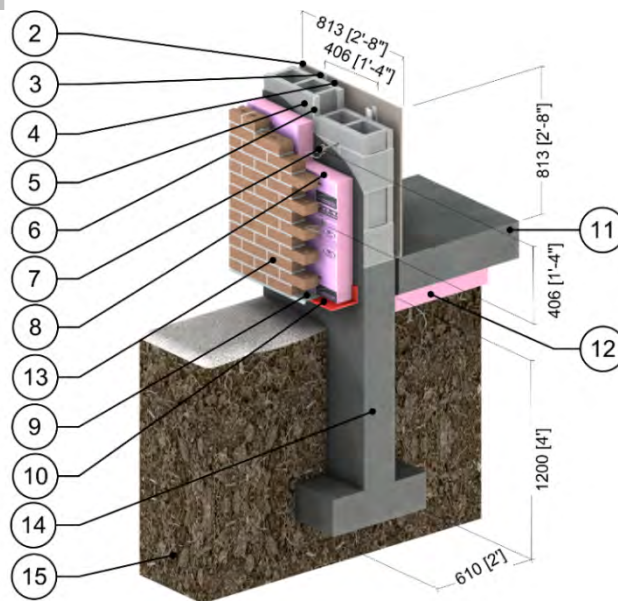

ID	Component	Thickness Inches (mm)	Conductivity Btu-in / ft ² -hr-°F (W/m K)	Nominal Resistance hr-ft ² -°F/Btu (m ² K/W)	Density lb/ft ³ (kg/m ³)	Specific Heat Btu/lb-°F (J/kg K)
1	Interior Film ¹	-	-	R-0.7 to R-0.9 (0.12 to 0.16 RSI)	-	-
2	Gypsum Board	1/2" (13)	1.1 (0.16)	R-0.5 (0.08 RSI)	50 (800)	0.26 (1090)
3	1 5/8" Steel Studs with Bottom Track	20 gauge	430 (62)	-	489 (7830)	0.12 (500)
4	Air in Stud Cavity	1 5/8" (41)	-	R-0.9 (0.16 RSI)	0.075 (1.2)	0.24 (1000)
5	Standard Concrete Block	7 5/8" (190)	3.5 (0.5)	-	119 (1900)	0.19 (800)
6	Cement Mortar	-	3.5 (0.5)	-	113 (1800)	0.12 (500)
7	Heckmann Pos-I-Tie Masonry Tie @ 16" (406) o.c.	varies	-	-	-	-
8	Foamular CodeBord/C-200 Extruded Polystyrene (XPS) Rigid Insulation Type 3	varies	0.20 (0.029)	R-10 to R-20 (1.76 to 3.52 RSI)	1.8 (28)	0.29 (1220)
9	Steel Shelf Angle	3/8" (10)	347 (50)	-	489 (7830)	0.12 (500)
10	Metal Flashing	20 gauge	430 (62)	-	489 (7830)	0.12 (500)
11	Concrete Slab on Grade	8" (203)	12.5 (1.8)	-	140 (2250)	0.20 (850)
12	Foamular XPS Insulation	3 1/2" (89)	0.20 (0.029)	R-17.5 (3.08 RSI)	1.8 (28)	0.29 (1220)
13	Brick Veneer	3 5/8" (92)	5.4 (0.78)	-	120 (1920)	0.19 (720)
14	Concrete Footing	24" (610)	12.5 (1.8)	-	140 (2250)	0.20 (850)
15	Soil	-	15.6 (2.25)	-	-	-
16	Exterior Film ¹	-	-	R-0.2 (0.03 RSI)	-	-

¹ Value selected from table 1, p. 26.1 of 2009 ASHRAE Handbook – Fundamentals depending on surface orientation

Detail 7.7.10

Owens Corning Exterior Insulated Concrete Block Wall Assembly with Stainless Steel Stand-off Shelf Angle and Heckmann Pos-I-Tie Veneer Anchoring System Supporting Brick Veneer and Insulation Below Floor – Slab on Grade and Foundation Intersection

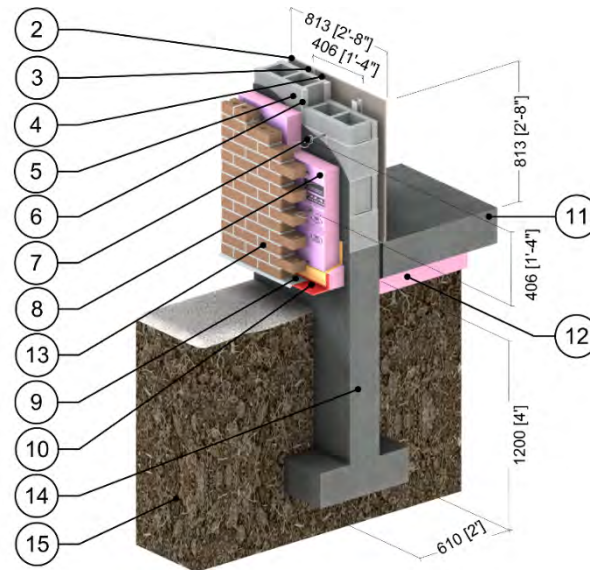

ID	Component	Thickness Inches (mm)	Conductivity Btu-in / ft ² ·hr·°F (W/m K)	Nominal Resistance hr·ft ² ·°F/Btu (m ² K/W)	Density lb/ft ³ (kg/m ³)	Specific Heat Btu/lb·°F (J/kg K)
1	Interior Film ¹	-	-	R-0.7 to R-0.9 (0.12 to 0.16 RSI)	-	-
2	Gypsum Board	1/2" (13)	1.1 (0.16)	R-0.5 (0.08 RSI)	50 (800)	0.26 (1090)
3	1 5/8" Steel Studs with Bottom Track	20 gauge	430 (62)	-	489 (7830)	0.12 (500)
4	Air in Stud Cavity	1 5/8" (41)	-	R-0.9 (0.16 RSI)	0.075 (1.2)	0.24 (1000)
5	Standard Concrete Block	7 5/8" (190)	3.5 (0.5)	-	119 (1900)	0.19 (800)
6	Cement Mortar	-	3.5 (0.5)	-	113 (1800)	0.12 (500)
7	Heckmann Pos-I-Tie Masonry Tie @ 16" (406) o.c.	varies	-	-	-	-
8	Foamular CodeBord/C-200 Extruded Polystyrene (XPS) Rigid Insulation Type 3	varies	0.20 (0.029)	R-10 to R-20 (1.76 to 3.52 RSI)	1.8 (28)	0.29 (1220)
9	Stainless Steel Stand-off Shelf Angle	3/8" (10)	118 (17)	-	503 (8060)	0.12 (500)
10	Metal Flashing	20 gauge	430 (62)	-	489 (7830)	0.12 (500)
11	Concrete Slab on Grade	8" (203)	12.5 (1.8)	-	140 (2250)	0.20 (850)
12	Foamular XPS Insulation	3 1/2" (89)	0.20 (0.029)	R-17.5 (3.08 RSI)	1.8 (28)	0.29 (1220)
13	Brick Veneer	3 5/8" (92)	5.4 (0.78)	-	120 (1920)	0.19 (720)
14	Concrete Footing	24" (610)	12.5 (1.8)	-	140 (2250)	0.20 (850)
15	Soil	-	15.6 (2.25)	-	-	-
16	Exterior Film ¹	-	-	R-0.2 (0.03 RSI)	-	-

¹ Value selected from table 1, p. 26.1 of 2009 ASHRAE Handbook – Fundamentals depending on surface orientation

Detail 7.8.1

Precast Sandwich Panel Wall Assembly – Emloc Thermally Broken Embedment Detail

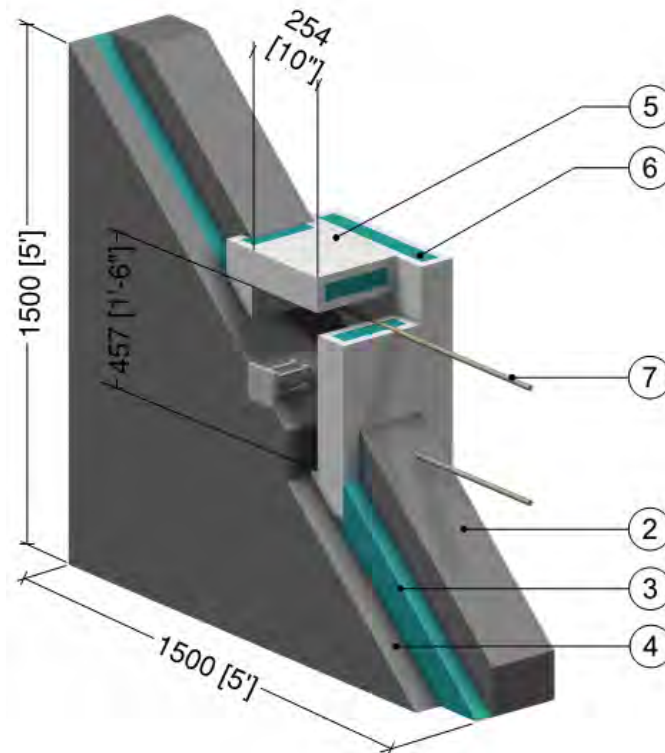

ID	Component	Thickness Inches (mm)	Conductivity Btu-in / ft ² ·hr·°F (W/m K)	Nominal Resistance hr·ft ² ·°F/Btu (m ² K/W)	Density lb/ft ³ (kg/m ³)	Specific Heat Btu/lb·°F (J/kg K)
1	Interior Film ¹	-	-	R-0.7 (0.12 RSI)	-	-
2	Precast Sandwich Panel, Interior Concrete Panel	7 3/4" (197)	12.5 (1.8)	-	140 (2250)	0.20 (850)
3	Precast Sandwich Panel Insulation	2" to 4" (51 to 102)	-	R-10 to R-20 (1.8 RSI to 3.5 RSI)	1.8 (28)	0.29 (1220)
4	Precast Sandwich Panel, Exterior Concrete Panel	3" (76)	12.5 (1.8)	-	140 (2250)	0.20 (850)
5	Emloc, PVC Foam	1" (25)	0.42 (0.06)	-	-	-
6	Emloc, Insulation	2" to 4" (51 to 102)	-	R-10 to R-20 (1.8 RSI to 3.5 RSI)	1.8 (28)	0.29 (1220)
7	FRP rebar	#5 (16M)	2.4 (0.35)	-	-	-
8	Exterior Film ¹	-	-	R-0.2 (0.03 RSI)	-	-

¹ Value selected from table 1, p. 26.1 of 2009 ASHRAE Handbook – Fundamentals depending on surface orientation

² The thermal conductivity of air spaces within framing was found using ISO 100077-2

8.0 Wood-Frame and Timber Construction

Detail 8.1.1	A.8.1
Interior Insulated 2x4 Wood Stud Wall Assembly – Clear Wall	
Detail 8.1.2	A.8.2
Interior Insulated 2x6 Wood Stud Wall Assembly – Clear Wall	
Detail 8.1.3	A.8.3
Interior Insulated 2x6 Wood Stud (16” o.c.) Wall Assembly with Wood Strapping Supporting Fiber Cement Board and R-19 Batt Insulation in Stud Cavity – Clear Wall	
Detail 8.1.4	A.8.4
Exterior and Interior Insulated 2x6 Wood Stud (16” o.c.) Wall Assembly with Wood Strapping Supporting Fiber Cement Board and R-19 Batt Insulation in Stud Cavity – Clear Wall	
Detail 8.1.5	A.8.5
Exterior and Interior Insulated 2x6 Wood Stud (16” o.c.) Wall Assembly with Continuous Rigid Insulation Supporting Fiber Cement Board and R-19 Batt Insulation in Stud Cavity – Clear Wall	
Detail 8.1.6	A.8.6
Exterior and Interior Insulated 2x6 Wood Stud (16” o.c.) Wall Assembly with Horizontal Metal Z-Girts (24” o.c.) Supporting Fiber Cement Board and R-19 Batt Insulation in Stud Cavity – Clear Wall	
Detail 8.1.7	A.8.7
Exterior Insulated 2x6 Wood Stud (16” o.c.) Wall Assembly with Knight MFI-System (24” o.c.) Supporting Cladding – Clear Wall	
Detail 8.1.8	A.8.8
Exterior and Interior Insulated 2x6 Wood Stud (16” o.c.) Wall Assembly with Knight MFI-System (24” o.c.) Supporting Cladding and R-19 Batt Insulation in Stud Cavity – Clear Wall	
Detail 8.1.9	A.8.9
Exterior Insulated 2x6 Wood Stud (16”o.c.) Wall Assembly with Thermally Broken Aluminum Clip Rail System (24” o.c.) Supporting Cladding – Clear Wall	
Detail 8.1.10	A.8.10
Interior Insulated Double Framed Wall 2x6 and 2x4 Wood Stud (16” o.c.) Wall Assembly with 2” Gap – Clear Wall	
Detail 8.1.11	A.8.11
Interior Insulated Double Framed Wall 2x6 and 2x4 Wood Stud (16” o.c.) Wall Assembly with 3” Gap – Clear Wall	
Detail 8.1.12	A.8.12
Interior Insulated Double Framed Wall 2x6 and 2x4 Wood Stud (16” o.c.) Wall Assembly with 4” Gap – Clear Wall	
Detail 8.1.13	A.8.13

Interior Insulated Cross Laminated Timber (CLT) Spandrel with ISO-CONNECT Anchor – Anchor Point Transmittance	
Detail 8.1.14	A.8.14
Exterior and Interior Insulated 2"x6" Wood Stud (16" o.c. and 24" o.c.) Wall Assembly with Heckmann Pos-I-Tie Veneer Anchoring System Supporting Brick Veneer and Owens Corning R-19 Batt Insulation in Stud Cavity – Clear Wall	
Detail 8.1.15	A.8.15
Exterior and Interior Insulated 2"x6" Wood Stud (16" o.c. and 24" o.c.) Wall Assembly with Heckmann Pos-I-Tie Veneer Anchoring System Supporting Brick Veneer and Owens Corning R-22 Batt Insulation in Stud Cavity – Clear Wall	
Detail 8.1.16	A.8.16
Exterior and Interior Insulated 2"x6" Wood Stud (16" o.c. and 24" o.c.) Wall Assembly with Heckmann Pos-I-Tie Veneer Anchoring System Supporting Brick Veneer and Owens Corning R-24 Batt Insulation in Stud Cavity – Clear Wall	
Detail 8.1.17	A.8.17
Exterior Insulated Cross Laminated Timber (CLT) Wall Assembly with Continuous Rigid Insulation Supporting Fiber Cement Board – Clear Wall	
Detail 8.1.18	A.8.18
Exterior Insulated Cross Laminated Timber (CLT) Wall Assembly with Wood Strapping and Continuous Rigid Insulation Supporting Fiber Cement Board	
Detail 8.1.19	A.8.19
Exterior and Interior Insulated 2x6 Wood Stud (16" o.c.) Wall Assembly with Brick Ties Supporting Brick Veneer and R-19 Batt Insulation in Stud Cavity – Clear Wall	
Detail 8.1.20	A.8.20
Exterior Insulated 2x6 Wood Stud (16" o.c.) Wall with Interior OSB and Wood Furring Assembly & Brick Ties Supporting Brick Veneer – Clear Wall	
Detail 8.1.21	A.8.21
Exterior and Interior Insulated 2x6 Wood Stud (16" o.c.) Wall with Interior OSB and Wood Furring Assembly & Brick Ties Supporting Brick Veneer – Clear Wall	
Detail 8.1.22	A.8.22
Exterior Insulated 2x6 Wood Stud (16" o.c.) Wall with Interior Wood Furring Assembly & Brick Ties Supporting Brick Veneer – Clear Wall	
Detail 8.1.23	A.8.23
Exterior and Interior Insulated 2x6 Wood Stud (16" o.c.) Wall with Interior Wood Furring Assembly & Brick Ties Supporting Brick Veneer – Clear Wall	
Detail 8.1.24	A.8.24
Interior Insulated Double Framed Wall 2x6 and 2x4 Wood Stud (16" o.c.) Wall Assembly with 1" Gap – Clear Wall	
Detail 8.1.25	A.8.25

Exterior and Interior Insulated 2x6 Wood Stud (16" o.c.) Wall Assembly with SOPREMA SOPRA-XPS 20 and ACS-S Thermal Clip Supporting Metal Cladding with R-19 Cellulose Insulation in Stud Cavity - Clear Wall	
Detail 8.1.26	A.8.26
Exterior and Interior Insulated 2x6 Wood Stud (24" o.c.) Wall Assembly with SOPREMA SOPRA-XPS 20 and ACS-S Thermal Clip Supporting Metal Cladding with R-19 Cellulose Insulation in Stud Cavity - Clear Wall	
Detail 8.1.27	A.8.27
Exterior and Interior Insulated 2x6 Wood Stud (16" o.c.) Wall Assembly with SOPREMA SOPRA-SPF 202 and ACS-S Thermal Clip Supporting Metal Cladding with R-19 Cellulose Insulation in Stud Cavity - Clear Wall	
Detail 8.1.28	A.8.28
Exterior and Interior Insulated 2x6 Wood Stud (24" o.c.) Wall Assembly with SOPREMA SOPRA-SPF 202 and ACS-S Thermal Clip Supporting Metal Cladding with R-19 Cellulose Insulation in Stud Cavity - Clear Wall	
Detail 8.1.29	A.8.29
Exterior and Interior Insulated 2x6 Wood Stud (16" o.c.) Wall Assembly with SOPREMA SOPRA-ISO V PLUS and ACS-S Thermal Clip Supporting Metal Cladding with R-19 Cellulose Insulation in Stud Cavity - Clear Wall	
Detail 8.1.30	A.8.30
Exterior and Interior Insulated 2x6 Wood Stud (24" o.c.) Wall Assembly with SOPREMA SOPRA-ISO V PLUS and ACS-S Thermal Clip Supporting Metal Cladding with R-19 Cellulose Insulation in Stud Cavity - Clear Wall	
Detail 8.1.31	A.8.31
Exterior and Interior Insulated 2x6 Wood Stud (16" o.c.) Wall Assembly with Mineral Wool and ACS-S Thermal Clip Supporting Metal Cladding with R-19 Cellulose Insulation in Stud Cavity - Clear Wall	
Detail 8.1.32	A.8.32
Exterior and Interior Insulated 2x6 Wood Stud (24" o.c.) Wall Assembly with Mineral Wool and ACS-S Thermal Clip Supporting Metal Cladding with R-19 Cellulose Insulation in Stud Cavity - Clear Wall	
Detail 8.1.33	A.8.33
Exterior and Interior Insulated 2x6 Wood Stud (16" o.c.) Wall Assembly with Protected SOPREMA SOPRA-ISO V PLUS and ACS-S Thermal Clip Supporting Metal Cladding with R-19 Cellulose Insulation in Stud Cavity - Clear Wall	
Detail 8.1.34	A.8.34
Exterior and Interior Insulated 2x6 Wood Stud (24" o.c.) Wall Assembly with Protected SOPREMA SOPRA-ISO V PLUS and ACS-S Thermal Clip Supporting Metal Cladding with R-19 Cellulose Insulation in Stud Cavity - Clear Wall	
Detail 8.1.35	A.8.35

Exterior and Interior Insulated 2x4 Wood Stud (16" o.c.) Wall Assembly with Protected SOPREMA SOPRA-ISO V PLUS and ACS-S Thermal Clip Supporting Metal Cladding with R-13 Cellulose Insulation in Stud Cavity - Clear Wall	
Detail 8.1.36	A.8.36
Exterior and Interior Insulated 2x4 Wood Stud (24" o.c.) Wall Assembly with Protected SOPREMA SOPRA-ISO V PLUS and ACS-S Thermal Clip Supporting Metal Cladding with R-13 Cellulose Insulation in Stud Cavity - Clear Wall	
Detail 8.1.37	A.8.37
Exterior and Interior Insulated 2x6 Wood Stud (8" o.c.) Wall Assembly with Wood Strapping and Continuous Insulation Supporting Rainscreen Fiber Cement Board and R-19 Batt Insulation in Stud Cavity – Clear Wall	
Detail 8.2.1	A.8.38
Exterior and Interior Insulated 2x6 Wood Stud (16" o.c.) Wall Assembly with Wood Strapping Supporting Fiber Cement Board and R-19 Batt Insulation in Stud Cavity - Rim Joist and Floor Intersection with Metal Flashing Bypassing Exterior Insulation	
Detail 8.2.2	A.8.39
Exterior and Interior Insulated 2x6 Wood Stud (16" o.c.) Wall Assembly with Wood Strapping Supporting Fiber Cement Board and R-19 Batt Insulation in Stud Cavity - Rim Joist and Floor Intersection without Metal Flashing Bypassing Exterior Insulation	
Detail 8.2.3	A.8.40
Exterior and Interior Insulated 2x6 Wood Stud (16" o.c.) Wall Assembly with Wood Strapping Supporting Fiber Cement Board and R-19 Batt Insulation in Stud Cavity - Cantilevered Wood Joist Balcony Intersection	
Detail 8.2.4	A.8.41
Exterior and Interior Insulated 2x6 Wood Stud (16" o.c.) Wall Assembly with Wood Strapping Supporting Fiber Cement Board and R-19 Batt Insulation in Stud Cavity – Independently Supported Balcony Intersection	
Detail 8.2.5	A.8.42
Exterior and Interior Insulated 2x6 Wood Stud (16" o.c.) Wall Assembly with Wood Strapping and Continuous Insulation Supporting Fiber Cement Board and R-19 Batt Insulation in Stud Cavity – Cantilevered Floor Intersection	
Detail 8.2.6	A.8.43
Interior Insulated Double Framed Wall 2x6 and 2x4 Wood Stud (16" o.c.) Wall Assembly with 2" Gap – Rim Joist and Floor Intersection	
Detail 8.2.7	A.8.44
Interior Insulated Double Framed Wall 2x6 and 2x4 Wood Stud (16" o.c.) Wall Assembly with 3" Gap – Rim Joist and Floor Intersection	
Detail 8.2.8	A.8.45

Interior Insulated Double Framed Wall 2x6 and 2x4 Wood Stud (16" o.c.) Wall Assembly with 4" Gap – Rim Joist and Floor Intersection	
Detail 8.2.9	A.8.46
Interior Insulated Double Framed Wall 2x6 and 2x4 Wood Stud (16" o.c.) Wall Assembly with 2" Gap – Insulated Rim Joist and Floor Intersection	
Detail 8.2.10	A.8.47
Interior Insulated Double Framed Wall 2x6 and 2x4 Wood Stud (16" o.c.) Wall Assembly with 3" Gap – Insulated Rim Joist and Floor Intersection	
Detail 8.2.11	A.8.48
Interior Insulated Double Framed Wall 2x6 and 2x4 Wood Stud (16" o.c.) Wall Assembly with 4" Gap – Insulated Rim Joist and Floor Intersection	
Detail 8.2.12	A.8.49
Exterior and Interior Insulated 2x6 Wood Stud (16" o.c.) Wall Assembly with Shelf Angle & Brick Ties Supporting Brick Veneer and R-19 Batt Insulation in Stud Cavity – Rim Joist and Floor Intersection	
Detail 8.2.13	A.8.50
Exterior and Interior Insulated 2x6 Wood Stud (16" o.c.) Wall Assembly with Stand-off (Knife Plate) Shelf Angle & Brick Ties Supporting Brick Veneer and R-19 Batt Insulation in Stud Cavity – Rim Joist and Floor Intersection	
Detail 8.2.14	A.8.51
Exterior Insulated 2x6 Wood Stud (16" o.c.) Wall with Interior OSB and Wood Furring Assembly with Stand-off (Knife Plate) Shelf Angle & Brick Ties Supporting Brick Veneer – CLT and Wood Truss Floor Intersection	
Detail 8.2.15	A.8.52
Exterior and Interior Insulated 2x6 Wood Stud (16" o.c.) Wall with Interior OSB and Wood Furring Assembly with Stand-off (Knife Plate) Shelf Angle & Brick Ties Supporting Brick Veneer – CLT and Wood Truss Floor Intersection	
Detail 8.2.16	A.8.53
Exterior Insulated 2x6 Wood Stud (16" o.c.) Wall with Interior Wood Furring Assembly with Stand-off (Knife Plate) Shelf Angle & Brick Ties Supporting Brick Veneer – CLT and Wood Truss Floor Intersection	
Detail 8.2.17	A.8.54
Exterior and Interior Insulated 2x6 Wood Stud (16" o.c.) Wall with Interior Wood Furring Assembly with Stand-off (Knife Plate) Shelf Angle & Brick Ties Supporting Brick Veneer – CLT and Wood Truss Floor Intersection	
Detail 8.2.18	A.8.55
Exterior and Interior Insulated 2x6 Wood Stud (8" o.c.) Wall Assembly with Wood Strapping and Continuous Insulation Supporting Rainscreen Fiber Cement Board and R-19 Batt Insulation in Stud Cavity – Intermediate Floor Intersection	
Detail 8.2.19	A.8.56

Exterior and Interior Insulated 2x6 Wood Stud (16" o.c.) Wall Assembly with Wood Strapping and Continuous Insulation Supporting Rainscreen Fiber Cement Board and R-19 Batt Insulation in Stud Cavity – Intermediate Floor Intersection	
Detail 8.3.1	A.8.57
Exterior and Interior Insulated 2x6 Wood Stud (16" o.c.) Wall Assembly with Wood Strapping and Continuous Insulation Supporting Rainscreen Fiber Cement Board – Vinyl Window Intersection	
Detail 8.3.2	A.8.58
Exterior and Interior Insulated 2x6 Wood Stud (16" o.c.) Wall Assembly with Wood Strapping and Continuous Insulation Supporting Rainscreen Fiber Cement Board – Aluminum Window Intersection	
Detail 8.3.3	A.8.59
Exterior and Interior Insulated 2x6 Wood Stud (8" o.c.) Wall Assembly with Wood Strapping and Continuous Insulation Supporting Rainscreen Fiber Cement Board – Vinyl Window Intersection	
Detail 8.3.4	A.8.60
Exterior Insulated 2x6 Wood Stud (16" o.c.) Wall Assembly with Wood Strapping and Continuous Insulation Supporting Rainscreen Fiber Cement Board – Triple Glazed Flange Mounted Vinyl Window Intersection with Window Positioned in Wood Framing	
Detail 8.3.5	A.8.61
Exterior and Interior Insulated 2x6 Wood Stud (16" o.c.) Wall Assembly with Wood Strapping and Continuous Insulation Supporting Rainscreen Fiber Cement Board and R-19 Batt Insulation in Stud Cavity – Triple Glazed Flange Mounted Vinyl Window Intersection with Window Positioned in Wood Framing	
Detail 8.3.6	A.8.62
Exterior Insulated 2x6 Wood Stud (16" o.c.) Wall Assembly with Wood Strapping (16" o.c.) and Continuous Insulation Supporting Rainscreen Fiber Cement Board – Triple Glazed High Performance Vinyl Window Intersection (Insulated Frames)	
Detail 8.3.7	A.8.63
Exterior and Interior Insulated 2x6 Wood Stud (16" o.c.) Wall Assembly with Wood Strapping (16" o.c.) and Continuous Insulation Supporting Rainscreen Fiber Cement Board and R-19 Batt Insulation in Stud Cavity – Triple Glazed High Performance Vinyl Window Intersection (Insulated Frames)	
Detail 8.3.8	A.8.64
Interior Insulated Cross Laminated Timber (CLT) Spandrel at Window and Dowel Laminated Timber (DLT) – Intermediate Floor Intersection with Edge of Floor and Glulam Beam Aligned	
Detail 8.3.9	A.8.65
Full Height Interior Insulated Cross Laminated Timber (CLT) Spandrel at Window and Dowel Laminated Timber (DLT) – Intermediate Floor Intersection with Edge of Floor and Glulam Beam Aligned	

Detail 8.3.10	A.8.66
Interior Insulated Cross Laminated Timber (CLT) Spandrel at Window and Dowel Laminated Timber (DLT) – Intermediate Floor Intersection with Edge of Floor and Glulam Beam Not Aligned	
Detail 8.3.11	A.8.67
Double Framed Wall with 2x6 and 2x4 Wood Studs (16” o.c.) and 2” Gap – Triple Glazed Flanged Fiberglass Window Intersection with Wood Blocking and Un-insulated Perimeter	
Detail 8.3.12	A.8.68
Double Framed Wall with 2x6 and 2x4 Wood Studs (16” o.c.) and 3” Gap – Triple Glazed Flanged Fiberglass Window Intersection with Wood Blocking and Un-insulated Perimeter	
Detail 8.3.13	A.8.69
Double Framed Wall with 2x6 and 2x4 Wood Studs (16” o.c.) and 4” Gap – Triple Glazed Flanged Fiberglass Window Intersection with Wood Blocking and Un-insulated Perimeter	
Detail 8.3.14	A.8.70
Double Framed Wall with 2x6 and 2x4 Wood Studs (16” o.c.) and 2” Gap – Triple Glazed Flanged Fiberglass Window Intersection with Wood Blocking and Insulated Perimeter	
Detail 8.3.15	A.8.71
Double Framed Wall with 2x6 and 2x4 Wood Studs (16” o.c.) and 3” Gap – Triple Glazed Flanged Fiberglass Window Intersection with Wood Blocking and Insulated Perimeter	
Detail 8.3.16	A.8.72
Double Framed Wall with 2x6 and 2x4 Wood Studs (16” o.c.) and 4” Gap – Triple Glazed Flanged Fiberglass Window Intersection with Wood Blocking and Insulated Perimeter	
Detail 8.3.17	A.8.73
Double Framed Wall with 2x6 and 2x4 Wood Studs (16” o.c.) Wall and 2” Gap – Triple Glazed Rebated Fiberglass Window Intersection and Un-Insulated Perimeter	
Detail 8.3.18	A.8.74
Double Framed Wall with 2x6 and 2x4 Wood Studs (16” o.c.) Wall and 3” Gap – Triple Glazed Rebated Fiberglass Window Intersection and Un-Insulated Perimeter	
Detail 8.3.19	A.8.75
Double Framed Wall with 2x6 and 2x4 Wood Studs (16” o.c.) Wall and 4” Gap – Triple Glazed Rebated Fiberglass Window Intersection and Un-Insulated Perimeter	
Detail 8.3.20	A.8.76

	Double Framed Wall with 2x6 and 2x4 Wood Studs (16" o.c.) Wall and 2" Gap – Triple Glazed Rebated Fiberglass Window Intersection with Insulation at Window Perimeter	
Detail 8.3.21	A.8.77
	Double Framed Wall with 2x6 and 2x4 Wood Studs (16" o.c.) Wall and 3" Gap – Triple Glazed Rebated Fiberglass Window Intersection with Insulation at Window Perimeter	
Detail 8.3.22	A.8.78
	Double Framed Wall with 2x6 and 2x4 Wood Studs (16" o.c.) Wall and 4" Gap – Triple Glazed Rebated Fiberglass Window Intersection with Insulation at Window Perimeter	
Detail 8.3.23	A.8.79
	Exterior and Interior Insulated 2x6 Wood Stud (16" o.c.) Wall Assembly with Wood Strapping and Continuous Insulation Supporting Rainscreen Fiber Cement Board – Double Glazed Aluminum Window Intersection Aligned with Exterior Insulation	
Detail 8.4.1	A.8.80
	Exterior and Interior Insulated 2x6 Wood Stud (16" o.c.) Wall Assembly with Wood Strapping and Continuous Insulation Supporting Rainscreen Fiber Cement Board and R-19 Batt Insulation in Stud Cavity – Vented Low-slope Roof & Parapet Intersection	
Detail 8.4.2	A.8.81
	Exterior and Interior Insulated 2x6 Wood Stud (16" o.c.) Wall Assembly with Wood Strapping and Continuous Insulation Supporting Fiber Cement Board and R-19 Batt Insulation in Stud Cavity – Sloped Wood Framed Roof & Wall Intersection with Insulation at Ceiling	
Detail 8.4.3	A.8.82
	Exterior and Interior Insulated 2x6 Wood Stud (16" o.c.) Wall Assembly with Wood Strapping and Continuous Insulation Supporting Rainscreen Fiber Cement Board and R-19 Batt Insulation in Stud Cavity – Sloped Wood Framed Roof & Wall Intersection with Insulation at Roof Sheathing	
Detail 8.4.4	A.8.83
	Ventilated Wood Frame Low Slope Roof - Masonry Firewall Intersection	
Detail 8.4.5	A.8.84
	Exterior Insulated Cross Laminated Timber (CLT) Wall Assembly with Continuous Rigid Insulation Supporting Fiber Cement Board –Low-Slope Roof & Parapet Intersection	
Detail 8.5.1	A.8.85
	Exterior and Interior Insulated 2x6 Wood Stud (16" o.c.) Wall Assembly with Wood Strapping Supporting and Continuous Insulation Fiber Cement Board and R-19 Batt Insulation in Stud Cavity – Corner Intersection	
Detail 8.5.2	A.8.86

	Interior Insulated Double Framed Wall 2x6 and 2x4 Wood Stud (16" o.c.) Wall Assembly with 1" Gap – Corner Intersection	
Detail 8.6.1	A.8.87
	Wood-frame Sliding Door – Concrete Floor Intersection for Unheated Spaces (Parking Garages)	
Detail 8.6.2	A.8.88
	Exterior and Interior Insulated 2x6 Wood Stud (16" o.c.) Wall Assembly with Continuous Insulation and Wood Strapping Supporting Fiber Cement Board and R-19 Batt Insulation in Stud Cavity – Rim Joist and Interior Insulated At-Grade Foundation Wall Intersection	
Detail 8.6.3	A.8.89
	Exterior and Interior Insulated 2x6 Wood Stud (16" o.c.) Wall Assembly with Continuous Insulation and Wood Strapping Supporting Fiber Cement Board and R-19 Batt Insulation in Stud Cavity – Rim Joist and Exterior Insulated At-Grade Foundation Wall Intersection	
Detail 8.6.4	A.8.90
	Exterior and Interior Insulated 2x6 Wood Stud (16" o.c.) Wall Assembly with Shelf Angle & Brick Ties Supporting Brick Veneer and R-19 Batt Insulation in Stud Cavity – Exterior Insulated At-Grade Foundation Wall Intersection	
Detail 8.6.5	A.8.91
	Exterior Insulated Cross Laminated Timber (CLT) Wall Assembly with Continuous Rigid Insulation Supporting Fiber Cement Board – Concrete Slab and Exterior Insulated At-Grade Foundation Wall Intersection	
Detail 8.6.6	A.8.93
	Interior Insulated Double Framed Wall 2x6 and 2x4 Wood Stud (16" o.c.) Wall Assembly with 2" Gap – Rim Joist and Split Insulated At-Grade Foundation Wall Intersection	
Detail 8.6.7	A.8.94
	Interior Insulated Double Framed Wall 2x6 and 2x4 Wood Stud (16" o.c.) Wall Assembly with 2" Gap – Insulated Rim Joist and Split Insulated At-Grade Foundation Wall Intersection	
Detail 8.6.8	A.8.95
	Interior Insulated Double Framed Wall 2x6 and 2x4 Wood Stud (16" o.c.) Wall Assembly with 2" Gap and R28 ICF Foundation Wall – Rim Joist and Split Insulated At-Grade Foundation Wall Intersection	
Detail 8.6.9	A.8.96
	Interior Insulated Double Framed Wall 2x6 and 2x4 Wood Stud (16" o.c.) Wall Assembly with 2" Gap and R43 ICF Foundation Wall – Rim Joist and Split Insulated At-Grade Foundation Wall Intersection	
Detail 8.6.10	A.8.97

Interior Insulated Double Framed Wall 2x6 and 2x4 Wood Stud (16" o.c.) Wall Assembly with 2" Gap and Partially Wrapped R-22.5 Raft Slab Insulation – Slab on Grade Foundation Intersection

Detail 8.6.11**A.8.98**

Interior Insulated Double Framed Wall 2x6 and 2x4 Wood Stud (16" o.c.) Wall Assembly with 2" Gap and Partially Wrapped R-45 Raft Slab Insulation – Slab on Grade Foundation Intersection

Detail 8.6.12**A.8.99**

Interior Insulated Double Framed Wall 2x6 and 2x4 Wood Stud (16" o.c.) Wall Assembly with 2" Gap and Fully Wrapped R-22.5 Raft Slab Insulation – Slab on Grade Foundation Intersection

Detail 8.6.13**A.8.100**

Interior Insulated Double Framed Wall 2x6 and 2x4 Wood Stud (16" o.c.) Wall Assembly with 2" Gap and Fully Wrapped R-45 Raft Slab Insulation – Slab on Grade Foundation Intersection

Detail 8.6.14**A.8.101**

Interior Insulated Double Framed Wall 2x6 and 2x4 Wood Stud (16" o.c.) Wall Assembly with 2" Gap and R-22.5 Slab Insulation with Gravel Base – Slab on Grade Foundation Intersection

Detail 8.6.15**A.8.102**

Interior Insulated Double Framed Wall 2x6 and 2x4 Wood Stud (16" o.c.) Wall Assembly with 2" Gap and R-45 Slab Insulation with Gravel Base – Slab on Grade Foundation Intersection

Detail 8.7.1**A.8.103**

Exterior and Interior Insulated Wood Infill Wall Assembly with Wood Strapping and Continuous Insulation Supporting Fiber Cement Board and R-19 Batt Insulation in Stud Cavity – Concrete Wall and Intermediate Floor Intersection with Flashing Bypassing Exterior Insulation

Detail 8.7.2**A.8.104**

Exterior Insulated Cross Laminated Timber (CLT) Wall Assembly with Wood Strapping and Continuous Rigid Insulation Supporting Fiber Cement Board – Cross Laminated Timber Floor Intersection with Flashing Bypassing Exterior Insulation

Detail 8.7.3**A.8.105**

Exterior and Interior Insulated 2x6 Wood Stud (16" o.c.) Wall Assembly with Wood Strapping and Continuous Insulation Supporting Fiber Cement Board and R-19 Batt Insulation in Stud Cavity – One-Hour Fire Wall Intersection

Detail 8.1.1

Interior Insulated 2x4 Wood Stud Wall Assembly – Clear Wall

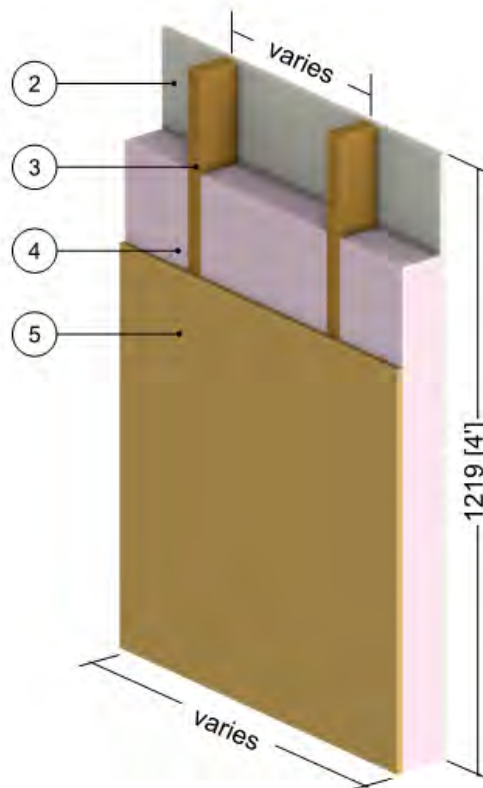

ID	Component	Thickness Inches (mm)	Conductivity Btu·in / ft ² ·hr·°F (W/m K)	Nominal Resistance hr·ft ² ·°F/Btu (m ² K/W)	Density lb/ft ³ (kg/m ³)	Specific Heat Btu/lb·°F (J/kg K)
1	Interior Film ¹	-	-	R-0.7 (0.12 RSI)	-	-
2	Gypsum Board	1/2" (13)	1.1 (0.16)	R-0.5 (0.08 RSI)	50 (800)	0.26 (1090)
3	2x4 Wood Stud (16" o.c.)	3 1/2" (89)	0.69 (0.10)	-	31 (500)	0.45 (1880)
4	Air or Fibreglass Batt Insulation in Stud Cavity	3 1/2" (89)	-	R-0.9 to R-13 (0.16 RSI to 2.28 RSI)	Varies	varies
5	Exterior Plywood Sheathing	1/2" (13)	0.69 (0.10)	R-0.7 (0.13 RSI)	31 (500)	0.45 (1880)
6	Cladding with 1/2" (13 mm) vented air space is incorporated into exterior heat transfer coefficient					
7	Exterior Film ¹	-	-	R-0.7 (0.12 RSI)	-	-

Detail 8.1.2

Interior Insulated 2x6 Wood Stud Wall Assembly – Clear Wall

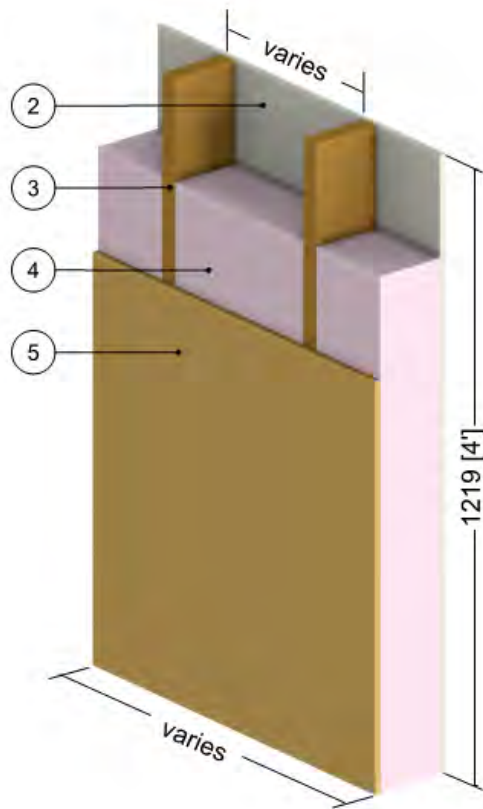

ID	Component	Thickness Inches (mm)	Conductivity Btu·in / ft ² ·hr·°F (W/m K)	Nominal Resistance hr·ft ² ·°F/Btu (m ² K/W)	Density lb/ft ³ (kg/m ³)	Specific Heat Btu/lb·°F (J/kg K)
1	Interior Film ¹	-	-	R-0.7 (0.12 RSI)	-	-
2	Gypsum Board	1/2" (13)	1.1 (0.16)	R-0.5 (0.08 RSI)	50 (800)	0.26 (1090)
3	2x6 Wood Stud (16" o.c.)	5 1/2" (140)	0.69 (0.10)	-	31 (500)	0.45 (1880)
4	Air or Fibreglass Batt Insulation in Stud Cavity	5 1/2" (140)	-	R-0.9 to R-30 (0.16 RSI to 5.28 RSI)	Varies	varies
5	Exterior Plywood Sheathing	1/2" (13)	0.69 (0.10)	R-0.7 (0.13 RSI)	31 (500)	0.45 (1880)
6	Metal cladding with 1/2" (13 mm) vented air space is incorporated into exterior heat transfer coefficient					
7	Exterior Film ¹	-	-	R-0.7 (0.12 RSI)	-	-

Detail 8.1.3

Interior Insulated 2x6 Wood Stud (16" o.c.) Wall Assembly with Wood Strapping Supporting Fiber Cement Board and R-19 Batt Insulation in Stud Cavity – Clear Wall

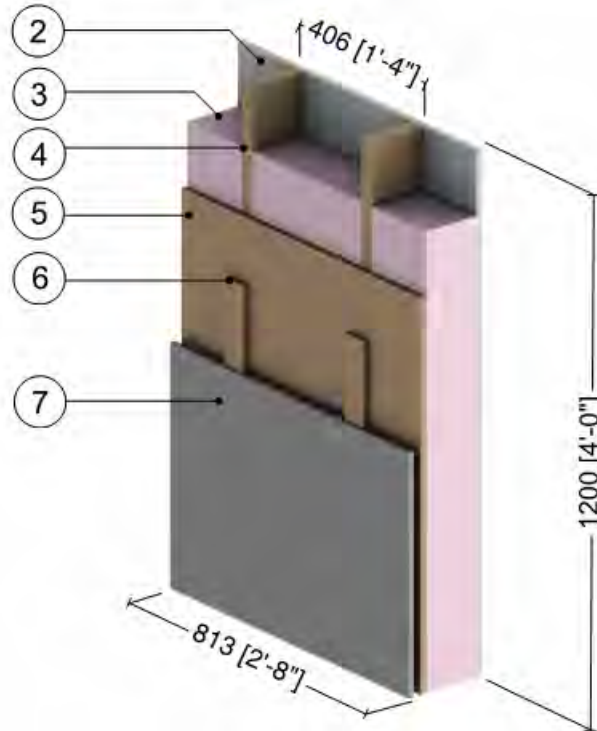

ID	Component	Thickness Inches (mm)	Conductivity Btu-in / ft ² ·hr·°F (W/m K)	Nominal Resistance hr·ft ² ·°F/Btu (m ² K/W)	Density lb/ft ³ (kg/m ³)	Specific Heat Btu/lb·°F (J/kg K)
1	Interior Film ¹	-	-	R-0.7 (0.12 RSI)	-	-
2	Gypsum Board	1/2" (13)	1.1 (0.16)	R-0.5 (0.08 RSI)	50 (800)	0.26 (1090)
3	Fiberglass Batt Insulation	5 1/2" (140)	0.29 (0.042)	R-19 (3.3 RSI)	0.9 (14)	0.17 (710)
4	2x6 Wood Stud (16" o.c.)	5 1/2" (140)	0.69 (0.10)	-	31 (500)	0.45 (1880)
5	Exterior wood Sheathing	1/2" (13)	0.69 (0.10)	R-0.7 (0.13 RSI)	31 (500)	0.45 (1880)
6	1x3 Wood Strapping	3/4" (19)	0.69 (0.10)	-	31 (500)	0.45 (1880)
7	Fiber Cement Board Cladding with 3/4" (19mm) vented airspace incorporated into exterior heat transfer coefficient					
8	Exterior Film ¹	-	-	R-0.7 (0.12 RSI)	-	-

¹ Value selected from table 1, p. 26.1 of 2009 ASHRAE Handbook – Fundamentals depending on surface orientation

Detail 8.1.4

Exterior and Interior Insulated 2x6 Wood Stud (16" o.c.) Wall Assembly with Wood Strapping Supporting Fiber Cement Board and R-19 Batt Insulation in Stud Cavity – Clear Wall

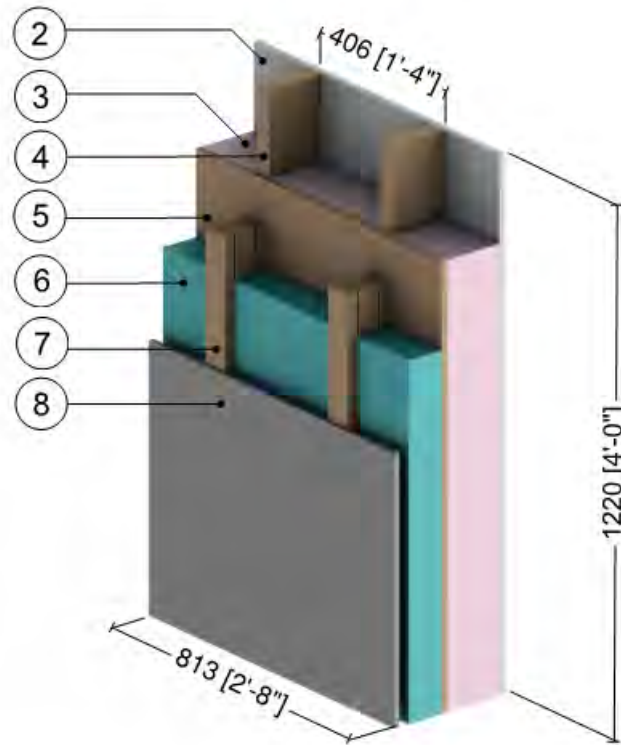

ID	Component	Thickness Inches (mm)	Conductivity Btu-in / ft ² ·hr·°F (W/m K)	Nominal Resistance hr·ft ² ·°F/Btu (m ² K/W)	Density lb/ft ³ (kg/m ³)	Specific Heat Btu/lb·°F (J/kg K)
1	Interior Film ¹	-	-	R-0.7 (0.12 RSI)	-	-
2	Gypsum Board	1/2" (13)	1.1 (0.16)	R-0.5 (0.08 RSI)	50 (800)	0.26 (1090)
3	Fiberglass Batt Insulation	5 1/2" (140)	0.29 (0.042)	R-19 (3.3 RSI)	0.9 (14)	0.17 (710)
4	2x6 Wood Stud (16" o.c.)	5 1/2" (140)	0.69 (0.10)	-	31 (500)	0.45 (1880)
5	Exterior Plywood Sheathing	1/2" (13)	0.69 (0.10)	R-0.7 (0.13 RSI)	31 (500)	0.45 (1880)
6	Exterior Insulation	Varies	-	R-5 to R-25 (0.88 RSI to 4.40 RSI)	1.8 (28)	0.29 (1220)
7	1x3 Wood Strapping (16" o.c.)	Varies	0.69 (0.10)	-	31 (500)	0.45 (1880)
8	Fiber Cement Board Cladding with 3/4" (19mm) vented airspace incorporated into exterior heat transfer coefficient					
9	Exterior Film ¹	-	-	R-0.7 (0.12 RSI)	-	-

¹ Value selected from table 1, p. 26.1 of 2009 ASHRAE Handbook – Fundamentals depending on surface orientation

Detail 8.1.5

Exterior and Interior Insulated 2x6 Wood Stud (16" o.c.) Wall Assembly with Continuous Rigid Insulation Supporting Fiber Cement Board and R-19 Batt Insulation in Stud Cavity – Clear Wall

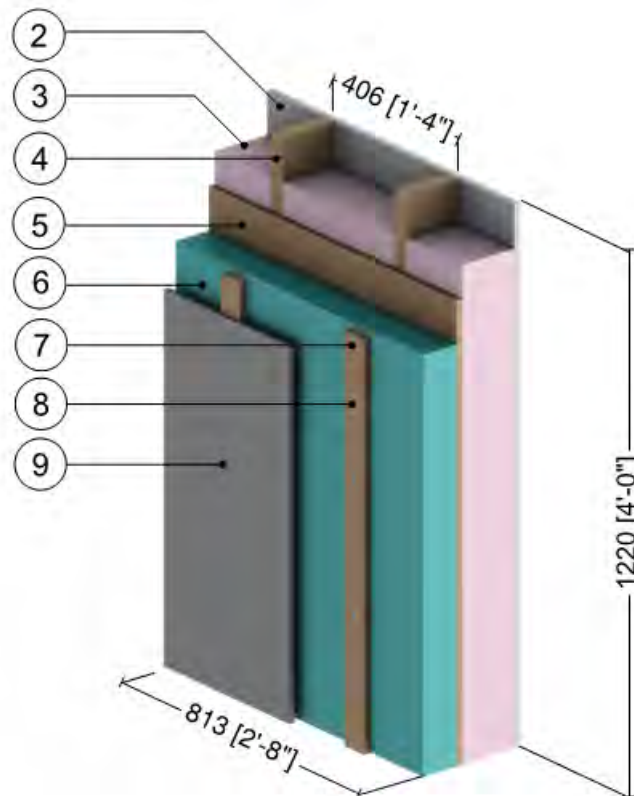

ID	Component	Thickness Inches (mm)	Conductivity Btu-in / ft ² ·hr·°F (W/m K)	Nominal Resistance hr·ft ² ·°F/Btu (m ² K/W)	Density lb/ft ³ (kg/m ³)	Specific Heat Btu/lb·°F (J/kg K)
1	Interior Film ¹	-	-	R-0.7 (0.12 RSI)	-	-
2	Gypsum Board	1/2" (13)	1.1 (0.16)	R-0.5 (0.08 RSI)	50 (800)	0.26 (1090)
3	Fiberglass Batt Insulation	5 1/2" (140)	0.29 (0.042)	R-19 (3.3 RSI)	0.9 (14)	0.17 (710)
4	2x6 Wood Stud (16" o.c.)	5 1/2" (140)	0.69 (0.10)	-	31 (500)	0.45 (1880)
5	Exterior Plywood Sheathing	1/2" (13)	0.69 (0.10)	R-0.7 (0.13 RSI)	31 (500)	0.45 (1880)
6	Exterior Insulation	Varies	-	R-5 to R-25 (0.88 RSI to 4.40 RSI)	1.8 (28)	0.29 (1220)
7	Wood Strapping (1" x 3")	3/4" (19)	0.69 (0.10)	-	31 (500)	0.45 (1880)
8	Steel Fasteners (12" o.c.)	0.44" (11) Ø	347 (50)	-	489 (7830)	0.12 (500)
9	Fiber Cement Board Cladding with 3/4" (19mm) vented airspace incorporated into exterior heat transfer coefficient					
10	Exterior Film ¹	-	-	R-0.7 (0.12 RSI)	-	-

¹ Value selected from table 1, p. 26.1 of 2009 ASHRAE Handbook – Fundamentals depending on surface orientation

Detail 8.1.6

Exterior and Interior Insulated 2x6 Wood Stud (16" o.c.) Wall Assembly with Horizontal Metal Z-Girts (24" o.c.) Supporting Fiber Cement Board and R-19 Batt Insulation in Stud Cavity – Clear Wall

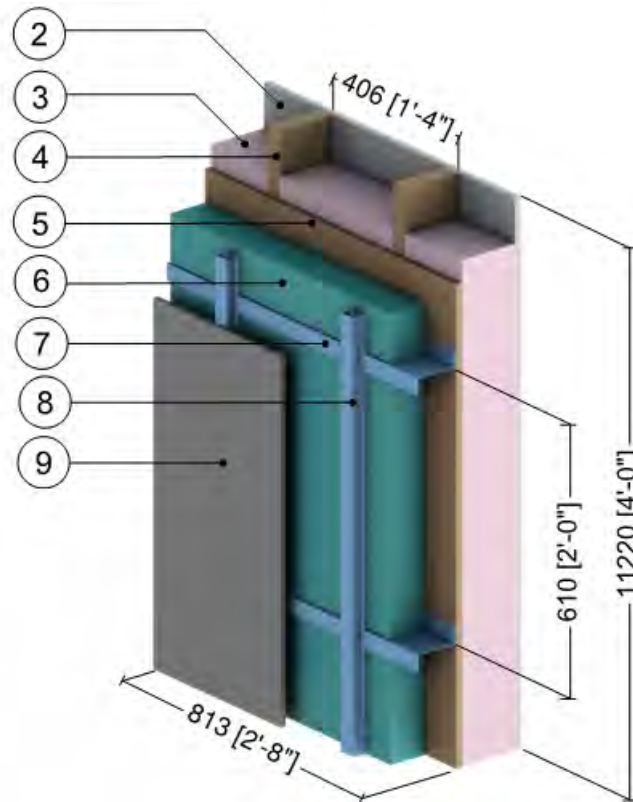

ID	Component	Thickness Inches (mm)	Conductivity Btu-in / ft ² ·hr·°F (W/m K)	Nominal Resistance hr·ft ² ·°F/Btu (m ² K/W)	Density lb/ft ³ (kg/m ³)	Specific Heat Btu/lb·°F (J/kg K)
1	Interior Film (right side) ¹	-	-	R-0.7 (0.12 RSI)	-	-
2	Gypsum Board	1/2" (13)	1.1 (0.16)	R-0.5 (0.08 RSI)	50 (800)	0.26 (1090)
3	Fiberglass Batt Insulation	5 1/2" (140)	0.29 (0.042)	R-19 (3.3 RSI)	0.9 (14)	0.17 (710)
4	2x6 Wood Stud (16" o.c.)	5 1/2" (140)	0.69 (0.10)	-	31 (500)	0.45 (1880)
5	Exterior Wood Sheathing	1/2" (13)	0.69 (0.10)	R-0.7 (0.13 RSI)	31 (500)	0.45 (1880)
6	Exterior Insulation	Varies	-	R-5 to R-25 (0.88 RSI to 4.40 RSI)	1.8 (28)	0.29 (1220)
7	Horizontal Z-Girt with 1 1/2" Flange	18 Gauge	430 (62)	-	489 (7830)	0.12 (500)
8	Steel Furring Hat Track (16" o.c.)	18 Gauge	430 (62)	-	489 (7830)	0.12 (500)
9	Fiber Cement Board Cladding with 3/4" (19mm) vented airspace incorporated into exterior heat transfer coefficient					
10	Exterior Film (left side) ¹	-	-	R-0.7 (0.12 RSI)	-	-

¹ Value selected from table 1, p. 26.1 of 2009 ASHRAE Handbook – Fundamentals depending on surface orientation

Detail 8.1.7

Exterior Insulated 2x6 Wood Stud (16" o.c.) Wall Assembly with Knight MFI-System (24" o.c.) Supporting Cladding – Clear Wall

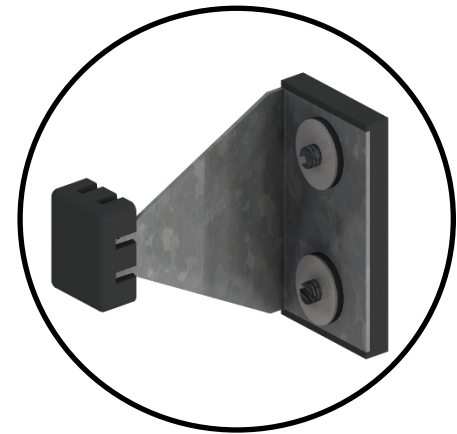
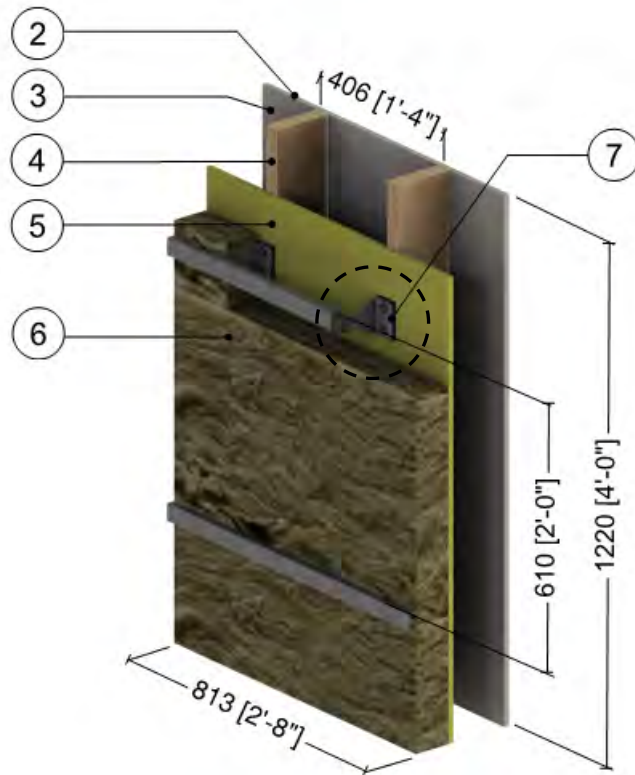

ThermaBracket Detail

ID	Component	Thickness Inches (mm)	Conductivity Btu-in / ft ² -hr-°F (W/m K)	Nominal Resistance hr-ft ² -°F/Btu (m ² K/W)	Density lb/ft ³ (kg/m ³)	Specific Heat Btu/lb-°F (J/kg K)
1	Interior Film ¹	-	-	R-0.7 (0.12 RSI)	-	-
2	Gypsum Board	1/2" (13)	1.1 (0.16)	R-0.5 (0.08 RSI)	50 (800)	0.26 (1090)
3	Air in Stud Cavity	5 1/2" (140)	-	R-0.9 (0.16 RSI)	0.075 (1.2)	0.24 (1000)
4	2x6 Wood Stud (16" o.c.)	5 1/2" (140)	0.83 (0.12)	-	31 (500)	0.45 (1880)
5	Exterior Sheathing	1/2" (13)	1.1 (0.16)	R-0.5 (0.08 RSI)	50 (800)	0.26 (1090)
6	Exterior Insulation	Varies	0.24 (0.03)	R-8.4 to R-25.2 (1.48 RSI to 4.44 RSI)	1.8 (28)	0.29 (1220)
7	ThermaBrackets (24" o.c. vertically)	18 Gauge	347 (50)	-	489 (7830)	0.12 (500)
8	Metal Cladding with 1/2" vented airspace incorporated into exterior heat transfer coefficient					
9	Exterior Film ¹	-	-	R-0.7 (0.12 RSI)	-	-

¹ Value selected from table 1, p. 26.1 of 2009 ASHRAE Handbook – Fundamentals depending on surface orientation

Detail 8.1.8

Exterior and Interior Insulated 2x6 Wood Stud (16" o.c.) Wall Assembly with Knight MFI-System (24" o.c.) Supporting Cladding and R-19 Batt Insulation in Stud Cavity – Clear Wall

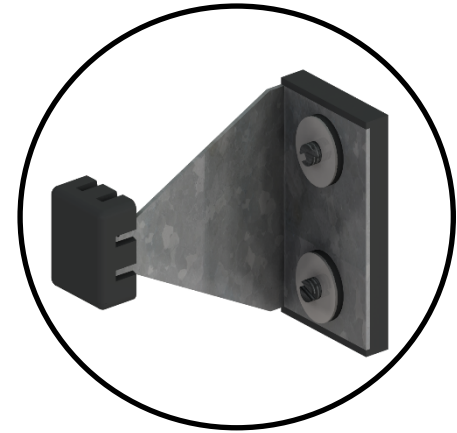
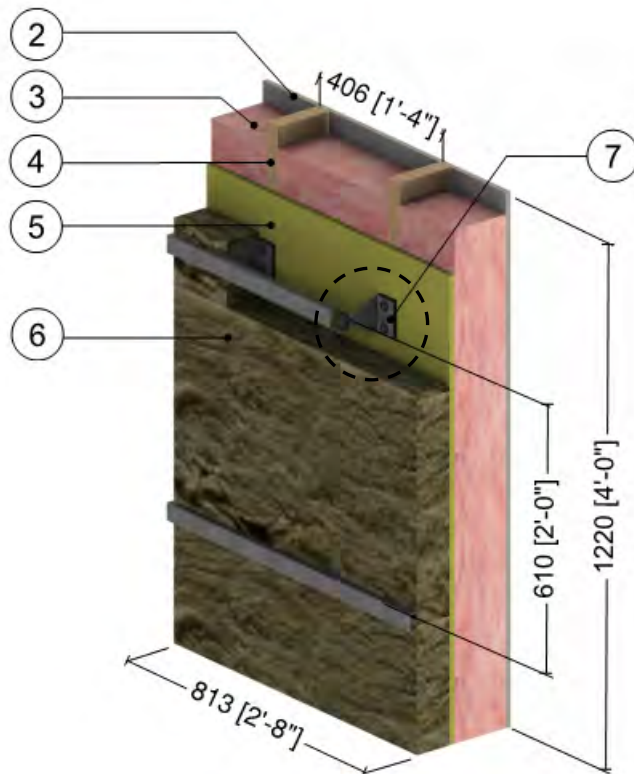

ThermaBracket Detail

ID	Component	Thickness Inches (mm)	Conductivity Btu-in / ft ² ·hr·°F (W/m K)	Nominal Resistance hr·ft ² ·°F/Btu (m ² K/W)	Density lb/ft ³ (kg/m ³)	Specific Heat Btu/lb·°F (J/kg K)
1	Interior Film ¹	-	-	R-0.7 (0.12 RSI)	-	-
2	Gypsum Board	1/2" (13)	1.1 (0.16)	R-0.5 (0.08 RSI)	50 (800)	0.26 (1090)
3	Fiberglass Batt Insulation	5 1/2" (140)	0.29 (0.042)	R-19 (3.35 RSI)	0.9 (14)	0.17 (710)
4	2x6 Wood Stud (16" o.c.)	5 1/2" (140)	0.83 (0.12)	-	31 (500)	0.45 (1880)
5	Exterior Sheathing	1/2" (13)	1.1 (0.16)	R-0.5 (0.08 RSI)	50 (800)	0.26 (1090)
6	Exterior Insulation	Varies	0.24 (0.03)	R-8.4 to R-25.2 (1.48 RSI to 4.44 RSI)	1.8 (28)	0.29 (1220)
7	ThermaBrackets (24" o.c. vertically)	18 Gauge	347 (50)	-	489 (7830)	0.12 (500)
8	Metal Cladding with 1/2" vented airspace incorporated into exterior heat transfer coefficient					
9	Exterior Film ¹	-	-	R-0.7 (0.12 RSI)	-	-

¹ Value selected from table 1, p. 26.1 of 2009 ASHRAE Handbook – Fundamentals depending on surface orientation

Detail 8.1.9

Exterior Insulated 2x6 Wood Stud (16" o.c.) Wall Assembly with Thermally Broken Aluminum Clip Rail System (24" o.c.) Supporting Cladding – Clear Wall

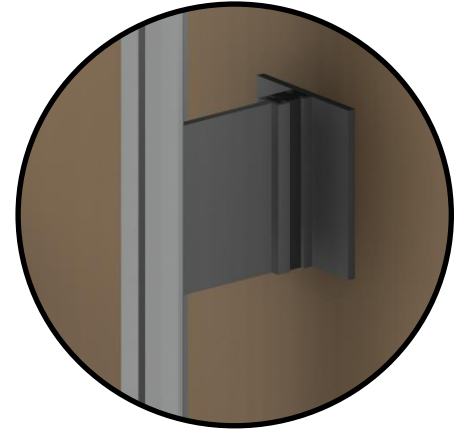
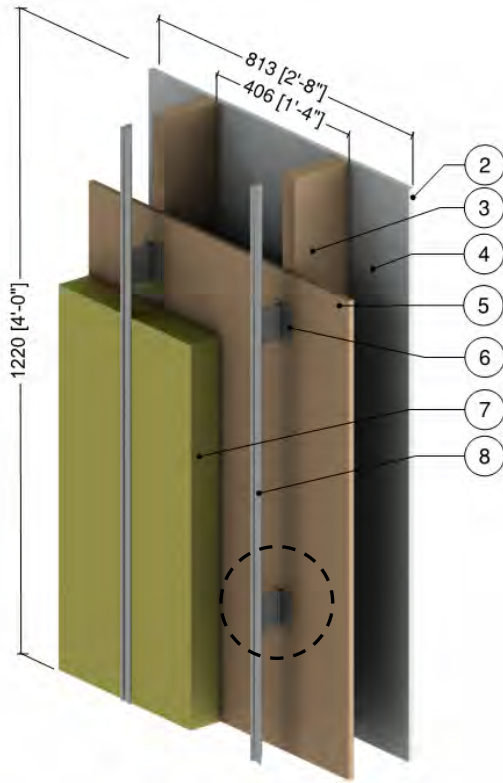

Clip Detail

ID	Component	Thickness Inches (mm)	Conductivity Btu-in / ft ² ·hr·°F (W/m K)	Nominal Resistance hr·ft ² ·°F/Btu (m ² K/W)	Density lb/ft ³ (kg/m ³)	Specific Heat Btu/lb·°F (J/kg K)
1	Interior Film ¹	-	-	R-0.7 (0.12 RSI)	-	-
2	Gypsum Board	1/2" (13)	1.1 (0.16)	R-0.5 (0.08 RSI)	50 (800)	0.26 (1090)
3	2x6 Wood Stud (16" o.c.)	5 1/2" (140)	0.7 (0.10)	-	31 (500)	0.45 (1880)
4	Air in Stud Cavity	5 1/2" (140)	-	R-0.9 (0.16 RSI)	0.075 (1.2)	0.24 (1000)
5	Exterior Wood Sheathing	1/2" (13)	0.7 (0.10)	R-0.7 (0.13 RSI)	31 (500)	0.45 (1880)
6	Longboard Aluminum Panel Clip	1/5" to 3/8" (5 to 10)	1110 (160)	-	-	-
7	Exterior Insulation	3" (76)	0.24 (0.03)	R-12.6 (2.22 RSI)	1.8 (28)	0.29 (1220)
8	Vertical Steel Girts	18 Gauge	430 (62)	-	489 (7830)	0.12 (500)
9	Cladding with 1/2" (13mm) vented airspace incorporated into exterior heat transfer coefficient					
10	Exterior Film ¹	-	-	R-0.7 (0.12 RSI)	-	-

¹ Value selected from table 1, p. 26.1 of 2009 ASHRAE Handbook – Fundamentals depending on surface orientation

Detail 8.1.10

Interior Insulated Double Framed Wall 2x6 and 2x4 Wood Stud (16" o.c.) Wall Assembly with 2" Gap – Clear Wall

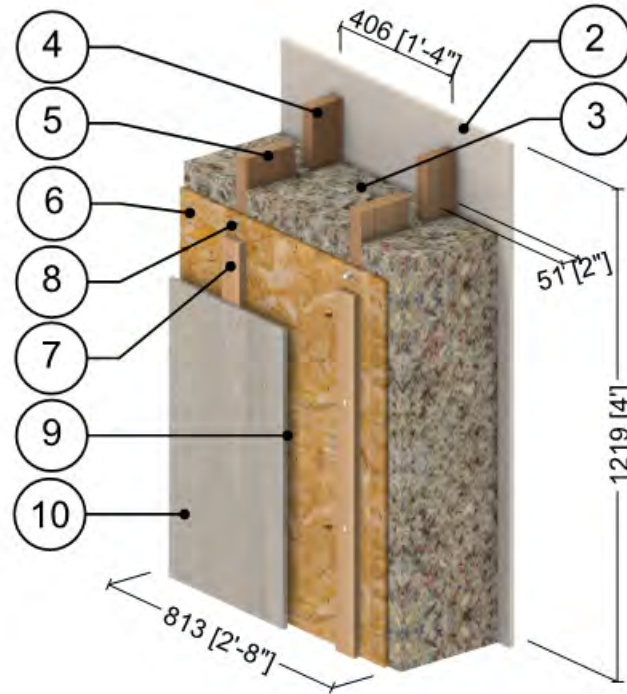

ID	Component	Thickness Inches (mm)	Conductivity Btu·in / ft ² ·hr·°F (W/m K)	Nominal Resistance hr·ft ² ·°F/Btu (m ² K/W)	Density lb/ft ³ (kg/m ³)	Specific Heat Btu/lb·°F (J/kg K)
1	Interior Film ¹	-	-	R-0.7 (0.12 RSI)	-	-
2	Gypsum Board	1/2" (13)	1.1 (0.16)	R-0.5 (0.08 RSI)	50 (800)	0.26 (1090)
3	Fill Insulation	11" (279)	0.17 (0.024) to 0.29 (0.041)	R-38.5 to R-66.0 (6.78 RSI to 11.62 RSI)	-	-
4	2x4 Wood Stud (16" o.c.)	3 1/2" (89)	0.69 (0.10)	-	31 (500)	0.45 (1880)
5	2x6 Wood Stud (16" o.c.)	5 1/2" (140)	0.69 (0.10)	-	31 (500)	0.45 (1880)
6	Exterior Plywood Sheathing	1/2" (13)	0.69 (0.10)	R-0.7 (0.13 RSI)	31 (500)	0.45 (1880)
7	Wood Strapping (1" x 3")	3/4" (19)	0.69 (0.10)	-	31 (500)	0.45 (1880)
8	Steel Fasteners (12" o.c.)	0.43" (11) Ø	347 (50)	-	489 (7830)	0.12 (500)
9	Rainscreen Cavity	3/4" (19)	-	R-0.4 (0.07 RSI)	0.075 (1.2)	0.24 (1000)
10	Fiber Cement Board	1/2" (13)	4.86 (0.7)	R-0.1 (0.02 RSI)	-	-
11	Exterior Film ¹	-	-	R-0.2 (0.03 RSI)	-	-

¹ Value selected from table 1, p. 26.1 of 2009 ASHRAE Handbook – Fundamentals depending on surface orientation

Detail 8.1.11

Interior Insulated Double Framed Wall 2x6 and 2x4 Wood Stud (16" o.c.) Wall Assembly with 3" Gap – Clear Wall

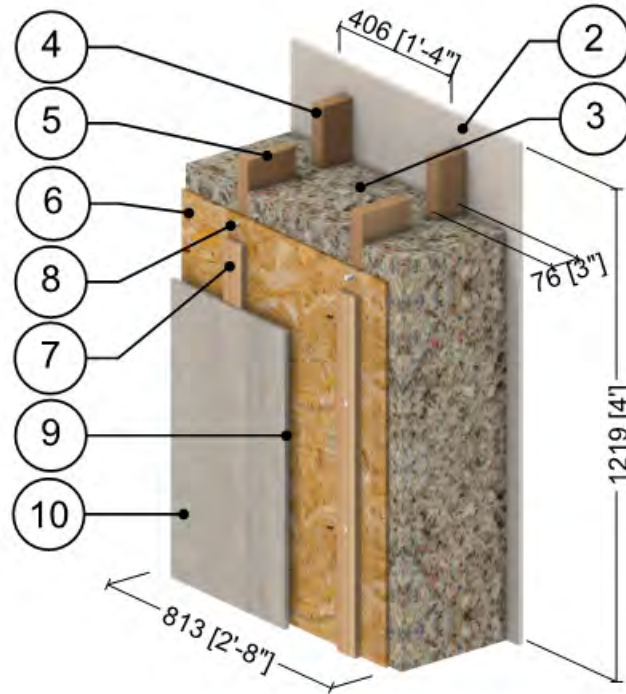

ID	Component	Thickness Inches (mm)	Conductivity Btu·in / ft ² ·hr·°F (W/m K)	Nominal Resistance hr·ft ² ·°F/Btu (m ² K/W)	Density lb/ft ³ (kg/m ³)	Specific Heat Btu/lb·°F (J/kg K)
1	Interior Film ¹	-	-	R-0.7 (0.12 RSI)	-	-
2	Gypsum Board	1/2" (13)	1.1 (0.16)	R-0.5 (0.08 RSI)	50 (800)	0.26 (1090)
3	Fill Insulation	12" (305)	0.17 (0.024) to 0.29 (0.041)	R-42.0 to R-72.0 (7.40 RSI to 12.68 RSI)	-	-
4	2x4 Wood Stud (16" o.c.)	3 1/2" (89)	0.69 (0.10)	-	31 (500)	0.45 (1880)
5	2x6 Wood Stud (16" o.c.)	5 1/2" (140)	0.69 (0.10)	-	31 (500)	0.45 (1880)
6	Exterior Plywood Sheathing	1/2" (13)	0.69 (0.10)	R-0.7 (0.13 RSI)	31 (500)	0.45 (1880)
7	Wood Strapping (1" x 3")	3/4" (19)	0.69 (0.10)	-	31 (500)	0.45 (1880)
8	Steel Fasteners (12" o.c.)	0.43" (11) Ø	347 (50)	-	489 (7830)	0.12 (500)
9	Rainscreen Cavity	3/4" (19)	-	R-0.4 (0.07 RSI)	0.075 (1.2)	0.24 (1000)
10	Fiber Cement Board	1/2" (13)	4.86 (0.7)	R-0.1 (0.02 RSI)	-	-
11	Exterior Film ¹	-	-	R-0.2 (0.03 RSI)	-	-

¹ Value selected from table 1, p. 26.1 of 2009 ASHRAE Handbook – Fundamentals depending on surface orientation

Detail 8.1.12

Interior Insulated Double Framed Wall 2x6 and 2x4 Wood Stud (16" o.c.) Wall Assembly with 4" Gap – Clear Wall

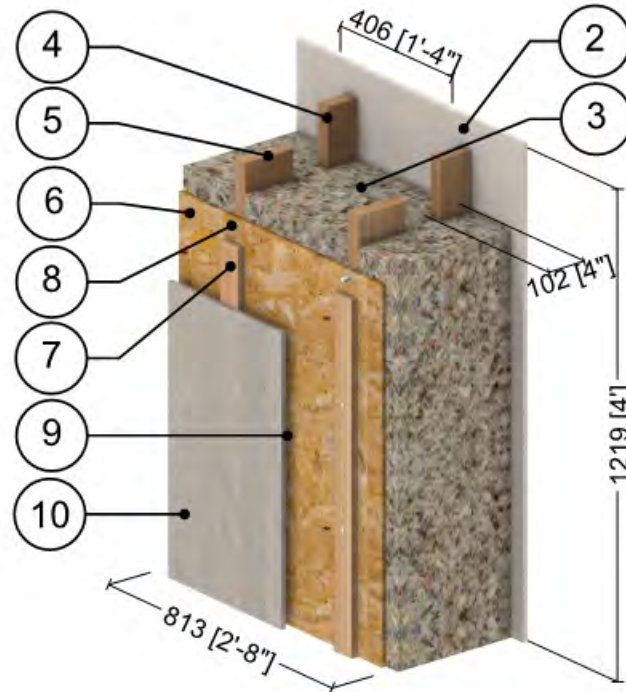

ID	Component	Thickness Inches (mm)	Conductivity Btu·in / ft ² ·hr·°F (W/m K)	Nominal Resistance hr·ft ² ·°F/Btu (m ² K/W)	Density lb/ft ³ (kg/m ³)	Specific Heat Btu/lb·°F (J/kg K)
1	Interior Film ¹	-	-	R-0.7 (0.12 RSI)	-	-
2	Gypsum Board	1/2" (13)	1.1 (0.16)	R-0.5 (0.08 RSI)	50 (800)	0.26 (1090)
3	Fill Insulation	13" (330)	0.17 (0.024) to 0.29 (0.041)	R-45.5 to R-78.0 (8.01 RSI to 13.74 RSI)	-	-
4	2x4 Wood Stud (16" o.c.)	3 1/2" (89)	0.69 (0.10)	-	31 (500)	0.45 (1880)
5	2x6 Wood Stud (16" o.c.)	5 1/2" (140)	0.69 (0.10)	-	31 (500)	0.45 (1880)
6	Exterior Plywood Sheathing	1/2" (13)	0.69 (0.10)	R-0.7 (0.13 RSI)	31 (500)	0.45 (1880)
7	Wood Strapping (1" x 3")	3/4" (19)	0.69 (0.10)	-	31 (500)	0.45 (1880)
8	Steel Fasteners (12" o.c.)	0.43" (11) Ø	347 (50)	-	489 (7830)	0.12 (500)
9	Rainscreen Cavity	3/4" (19)	-	R-0.4 (0.07 RSI)	0.075 (1.2)	0.24 (1000)
10	Fiber Cement Board	1/2" (13)	4.86 (0.7)	R-0.1 (0.02 RSI)	-	-
11	Exterior Film ¹	-	-	R-0.2 (0.03 RSI)	-	-

¹ Value selected from table 1, p. 26.1 of 2009 ASHRAE Handbook – Fundamentals depending on surface orientation

Detail 8.1.13

Interior Insulated Cross Laminated Timber (CLT) Spandrel with ISO-CONNECT Anchor – Anchor Point Transmittance

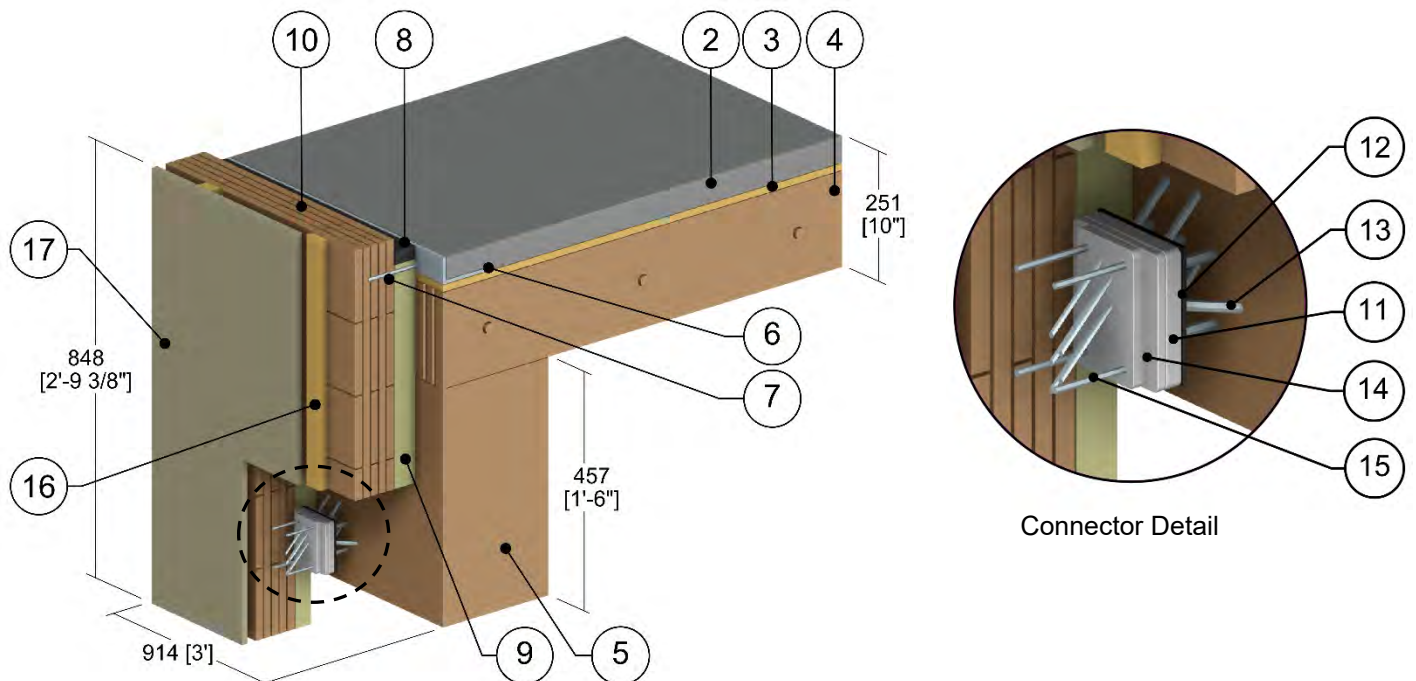

ID	Component	Thickness Inches (mm)	Conductivity Btu-in / ft ² -hr-°F (W/m K)	Nominal Resistance hr-ft ² -°F/Btu (m ² K/W)	Density lb/ft ³ (kg/m ³)	Specific Heat Btu/lb-°F (J/kg K)
1	Interior Film ¹	-	-	R-0.6 to R-1.1 (0.11 RSI to 0.20 RSI)	-	-
2	Concrete Topping	2" (51)	12.5 (1.8)	-	140 (2250)	0.20 (850)
3	Plywood	5/8" (16)	0.69 (0.10)	-	31 (500)	0.45 (1880)
4	DLT Floor	7 1/4" (184)	0.83 (0.12)	-	31 (500)	0.45 (1880)
5	Glulam Beam	9.5" (241)	0.97 (0.14)	R-9.8 (1.73 RSI)	31 (500)	0.45 (1880)
6	L-Angle	1/4" (6)	347 (50)	-	489 (7830)	0.12 (500)
7	Structural Screws 18" o.c.	ø 5/16" (8)	347 (50)	-	489 (7830)	0.12 (500)
8	Firestop Sealant	1" (25)	2.4 (0.35)	-	174 (2800)	0.17 (700)
9	Mineral Wool Insulation	Varies	0.24 (0.034)	R-8.4 to R-33.6 (1.48 RSI to 5.92 RSI)	4 (64)	0.20 (850)
10	CLT Panel	3.5" (89)	0.83 (0.12)	R-4.2 (0.79 RSI)	31 (500)	0.45 (1880)
11	ISO-CONNECT Plate	19/32" (15)	1110 (160)	-	171 (2740)	0.21 (900)
12	ISO-CONNECT Rubber Pad	1/8" (3)	1.7 (0.25)	-	-	-
13	ISO-CONNECT Fasteners x12	ø 5/16" (8)	347 (50)	-	489 (7830)	0.12 (500)
14	HVP Coupling Plates	19/32" (15)	1110 (160)	-	171 (2740)	0.21 (900)
15	HVP Fasteners x9	ø 3/16" (5)	347 (50)	-	489 (7830)	0.12 (500)
16	1" x 3" Wood Strapping	3/4" (19)	0.69 (0.10)	-	31 (500)	0.45 (1880)
17	Fiber Cement Board Cladding with 3/4" (19mm) vented airspace incorporated into exterior heat transfer coefficient					
18	Exterior Film ¹	-	-	R-0.7 (0.12 RSI)	-	-

¹ Value selected from table 1, p. 26.1 of 2009 ASHRAE Handbook – Fundamentals depending on surface orientation

Detail 8.1.14

Exterior and Interior Insulated 2"x6" Wood Stud (16" o.c. and 24" o.c.) Wall Assembly with Heckmann Pos-I-Tie Veneer Anchoring System Supporting Brick Veneer and Owens Corning R-19 Batt Insulation in Stud Cavity – Clear Wall

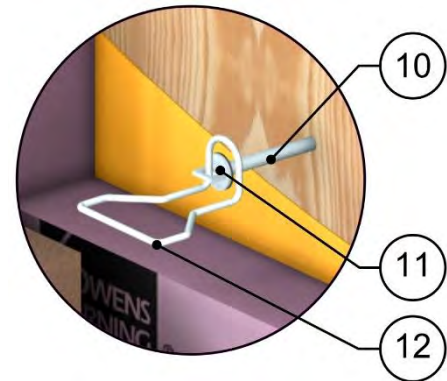
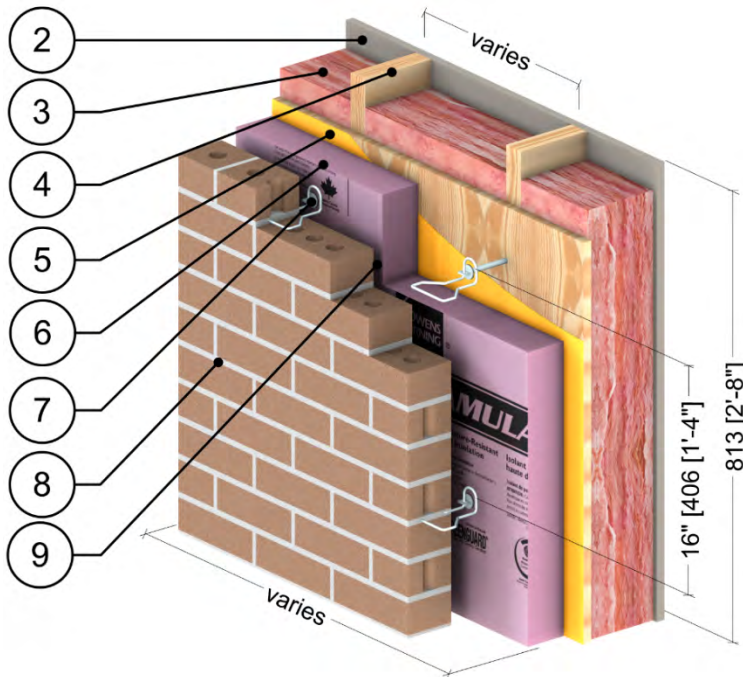

Anchor Detail

ID	Component	Thickness Inches (mm)	Conductivity Btu-in / ft ² -hr-°F (W/m K)	Nominal Resistance hr-ft ² -°F/Btu (m ² K/W)	Density lb/ft ³ (kg/m ³)	Specific Heat Btu/lb-°F (J/kg K)
1	Interior Film ¹	-	-	R-0.7 (0.12 RSI)	-	-
2	Gypsum Board	1/2" (13)	1.1 (0.16)	R-0.5 (0.08 RSI)	50 (800)	0.26 (1090)
3	Ecotouch Pink Fiberglass Batt	5 1/2" (140)	-	R-19 (3.35 RSI)	0.9 (14)	0.17 (710)
4	2x6 Wood Stud (16" o.c. and 24" o.c.)	5 1/2" (140)	0.69 (0.10)	-	31 (500)	0.45 (1880)
5	Exterior Wood Sheathing	1/2" (16)	0.69 (0.10)	R-0.7 (0.12 RSI)	31 (500)	0.45 (1880)
6	Foamular CodeBord/C-200 Extruded Polystyrene (XPS) Rigid Insulation Type 3	varies	0.20 (0.029)	R-10 to R-20 (1.76 to 3.52 RSI)	1.8 (28)	0.29 (1220)
7	Heckmann Pos-I-Tie Masonry Tie @ 16" (406) o.c.	varies	-	-	-	-
8	Brick Veneer	3 5/8" (92)	5.4 (0.78)	-	120 (1920)	0.19 (720)
9	Vented Air Cavity ²	1" (25)	-	R-0.9 (0.16 RSI)	0.075 (1.2)	0.24 (1000)
10	Zinc Barrel	-	726 (105)	-	412 (6600)	-
11	Rubber Washer (EPDM)	1/16" (1.59)	1.7 (0.25)	-	62 (997)	-
12	Galvanized Steel Wire Pintle	3/16" (5) Ø	645 (93)	-	489 (7830)	0.12 (500)
13	Exterior Film ¹	-	-	R-0.2 (0.03 RSI)	-	-

¹ Value selected from table 1, p. 26.1 of 2009 ASHRAE Handbook – Fundamentals depending on surface orientation

² The thermal conductivity of air spaces was found using ISO 100077-2

Detail 8.1.15

Exterior and Interior Insulated 2"x6" Wood Stud (16" o.c. and 24" o.c.) Wall Assembly with Heckmann Pos-I-Tie Veneer Anchoring System Supporting Brick Veneer and Owens Corning R-22 Batt Insulation in Stud Cavity – Clear Wall

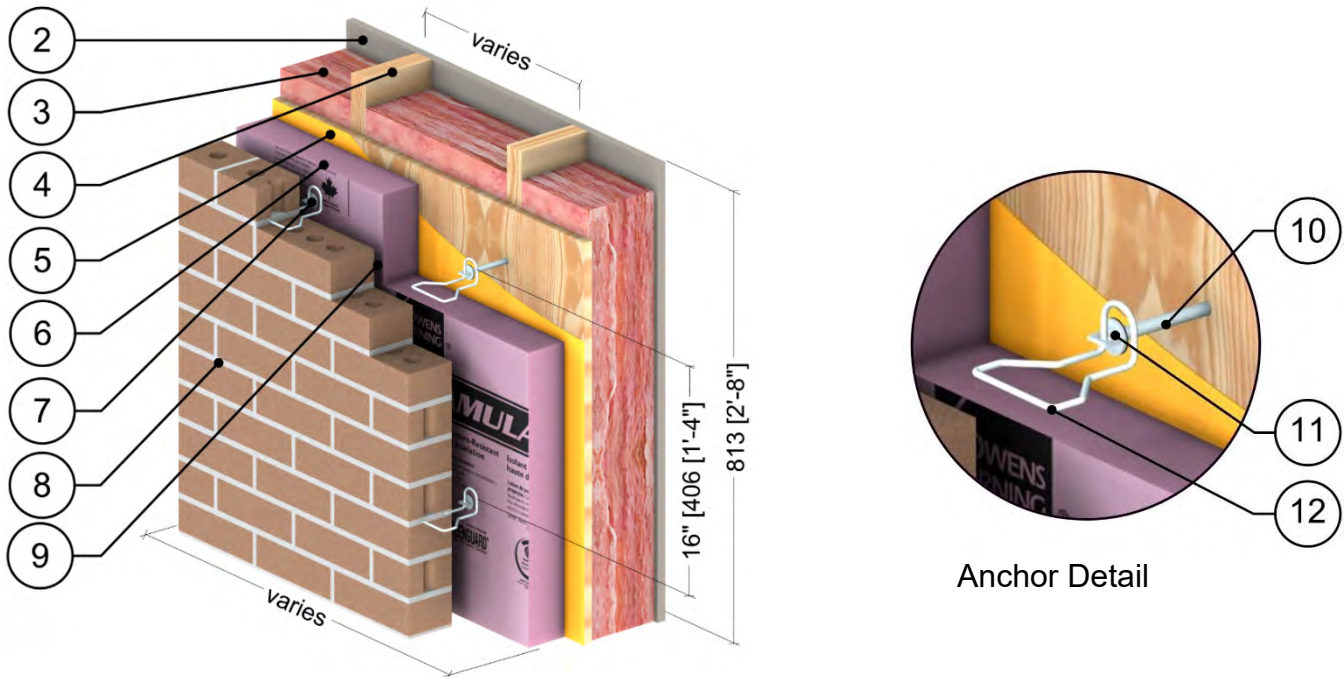

ID	Component	Thickness Inches (mm)	Conductivity Btu·in / ft ² ·hr·°F (W/m K)	Nominal Resistance hr·ft ² ·°F/Btu (m ² K/W)	Density lb/ft ³ (kg/m ³)	Specific Heat Btu/lb·°F (J/kg K)
1	Interior Film ¹	-	-	R-0.7 (0.12 RSI)	-	
2	Gypsum Board	1/2" (13)	1.1 (0.16)	R-0.5 (0.08 RSI)	50 (800)	0.26 (1090)
3	Ecotouch Pink Fiberglass Batt	5 1/2" (140)	-	R-22 (3.87 RSI)	0.9 (14)	0.17 (710)
4	2x6 Wood Stud (16" o.c. and 24" o.c.)	5 1/2" (140)	0.69 (0.10)	-	31 (500)	0.45 (1880)
5	Exterior Wood Sheathing	1/2" (16)	0.69 (0.10)	R-0.7 (0.12 RSI)	31 (500)	0.45 (1880)
6	Foamular CodeBord/C-200 Extruded Polystyrene (XPS) Rigid Insulation Type 3	varies	0.20 (0.029)	R-10 to R-20 (1.76 to 3.52 RSI)	1.8 (28)	0.29 (1220)
7	Heckmann Pos-I-Tie Masonry Tie @ 16" (406) o.c.	varies	-	-	-	-
8	Brick Veneer	3 5/8" (92)	5.4 (0.78)	-	120 (1920)	0.19 (720)
9	Vented Air Cavity ²	1" (25)	-	R-0.9 (0.16 RSI)	0.075 (1.2)	0.24 (1000)
10	Zinc Barrel	-	726 (105)	-	412 (6600)	-
11	Rubber Washer (EPDM)	1/16" (1.59)	1.7 (0.25)	-	62 (997)	-
12	Galvanized Steel Wire Pintle	3/16" (5) Ø	645 (93)	-	489 (7830)	0.12 (500)
13	Exterior Film ¹	-	-	R-0.2 (0.03 RSI)	-	-

¹ Value selected from table 1, p. 26.1 of 2009 ASHRAE Handbook – Fundamentals depending on surface orientation

² The thermal conductivity of air spaces was found using ISO 100077-2

Detail 8.1.16

Exterior and Interior Insulated 2"x6" Wood Stud (16" o.c. and 24" o.c.) Wall Assembly with Heckmann Pos-I-Tie Veneer Anchoring System Supporting Brick Veneer and Owens Corning R-24 Batt Insulation in Stud Cavity – Clear Wall

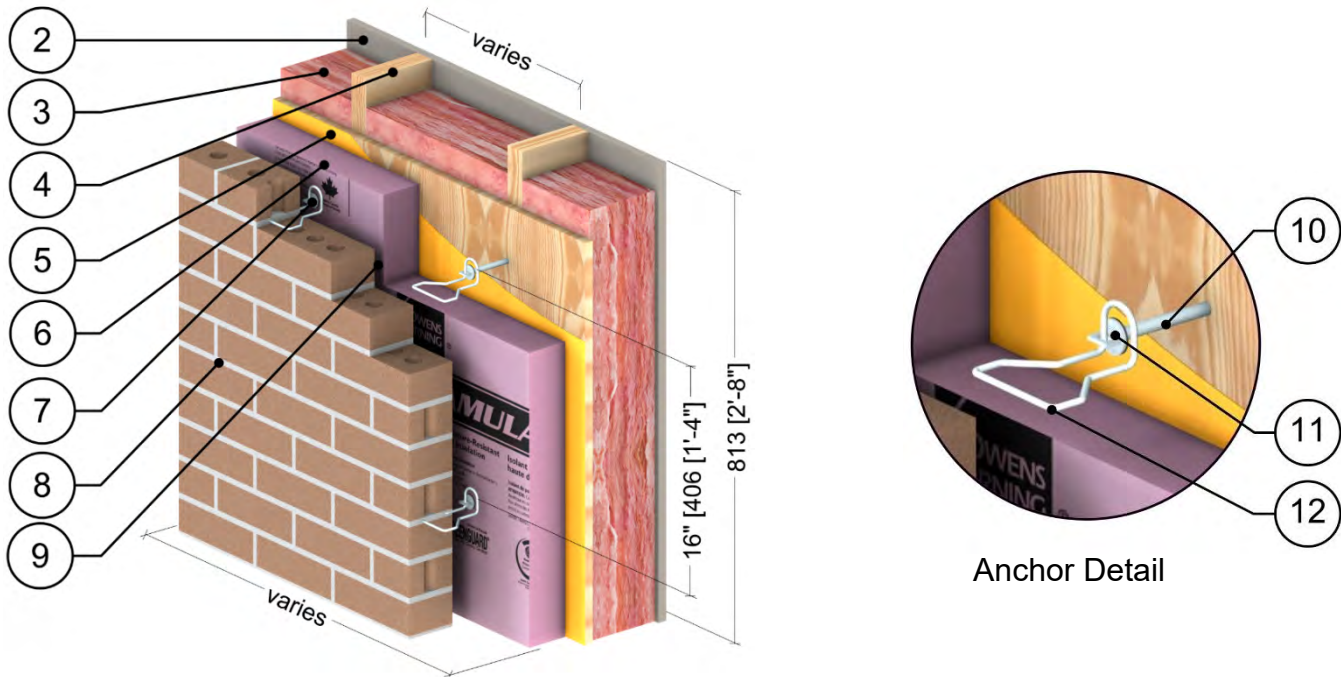

ID	Component	Thickness Inches (mm)	Conductivity Btu-in / ft ² -hr-°F (W/m K)	Nominal Resistance hr-ft ² -°F/Btu (m ² K/W)	Density lb/ft ³ (kg/m ³)	Specific Heat Btu/lb-°F (J/kg K)
1	Interior Film ¹	-	-	R-0.7 (0.12 RSI)	-	-
2	Gypsum Board	1/2" (13)	1.1 (0.16)	R-0.5 (0.08 RSI)	50 (800)	0.26 (1090)
3	Ecotouch Pink Fiberglass Batt	5 1/2" (140)	-	R-24 (4.23 RSI)	0.9 (14)	0.17 (710)
4	2x6 Wood Stud (16" o.c. and 24" o.c.)	5 1/2" (140)	0.69 (0.10)	-	31 (500)	0.45 (1880)
5	Exterior Wood Sheathing	1/2" (16)	0.69 (0.10)	R-0.7 (0.12 RSI)	31 (500)	0.45 (1880)
6	Foamular CodeBord/C-200 Extruded Polystyrene (XPS) Rigid Insulation Type 3	varies	0.20 (0.029)	R-10 to R-20 (1.76 to 3.52 RSI)	1.8 (28)	0.29 (1220)
7	Heckmann Pos-I-Tie Masonry Tie @ 16" (406) o.c.	varies	-	-	-	-
8	Brick Veneer	3 5/8" (92)	5.4 (0.78)	-	120 (1920)	0.19 (720)
9	Vented Air Cavity ²	1" (25)	-	R-0.9 (0.16 RSI)	0.075 (1.2)	0.24 (1000)
10	Zinc Barrel	-	726 (105)	-	412 (6600)	-
11	Rubber Washer (EPDM)	1/16" (1.59)	1.7 (0.25)	-	62 (997)	-
12	Galvanized Steel Wire Pintle	3/16" (5) Ø	645 (93)	-	489 (7830)	0.12 (500)
13	Exterior Film ¹	-	-	R-0.2 (0.03 RSI)	-	-

¹ Value selected from table 1, p. 26.1 of 2009 ASHRAE Handbook – Fundamentals depending on surface orientation

² The thermal conductivity of air spaces was found using ISO 100077-2

Detail 8.1.17

Exterior Insulated Cross Laminated Timber (CLT) Wall Assembly with Continuous Rigid Insulation Supporting Fiber Cement Board – Clear Wall

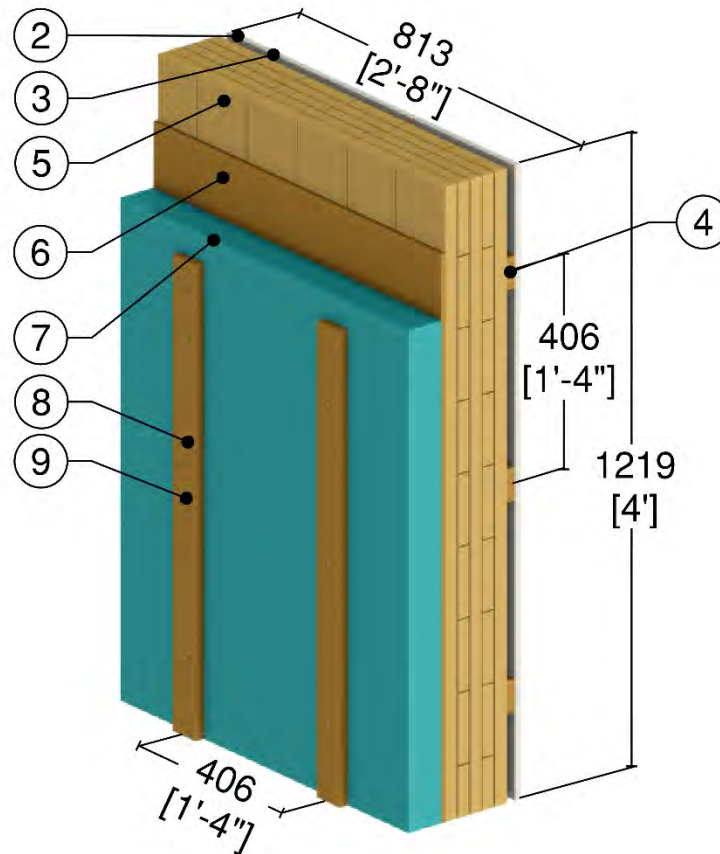

ID	Component	Thickness Inches (mm)	Conductivity Btu-in / ft ² -hr-°F (W/m K)	Nominal Resistance hr-ft ² -°F/Btu (m ² K/W)	Density lb/ft ³ (kg/m ³)	Specific Heat Btu/lb-°F (J/kg K)
1	Interior Film ¹	-	-	R-0.7 (0.12 RSI)	-	-
2	Gypsum Board	1/2" (13)	1.1 (0.16)	R-0.5 (0.08 RSI)	50 (800)	0.26 (1090)
3	Air in Cavity	3/4" (19)	-	R-0.9 (0.16 RSI)	0.075 (1.2)	0.24 (1000)
4	1x3 Wood Strapping (16" o.c.)	3/4" (19)	0.69 (0.10)	-	31 (500)	0.45 (1880)
5	Cross Laminated Timber Wall	5 1/2" (140)	0.83 (0.12)	R-6.6 (1.16 RSI)	31 (500)	0.45 (1880)
6	Plywood Sheathing	3/8" (9.5)	0.69 (0.10)	R-0.5 (0.10 RSI)	31 (500)	0.45 (1880)
7	Exterior Insulation	Varies	-	R-15 to R-25 (2.64 to 4.40 RSI)	1.8 (28)	0.29 (1220)
8	1x3 Wood Strapping (16" o.c.)	3/4" (19)	0.69 (0.10)	-	31 (500)	0.45 (1880)
9	#14 Steel Fasteners (12" o.c.)	0.24" (6.2) Ø	347 (50)	-	489 (7830)	0.12 (500)
10	Fiber Cement Board Cladding with 3/4" (19mm) vented airspace incorporated into exterior heat transfer coefficient					
11	Exterior Film ¹	-	-	R-0.7 (0.12 RSI)	-	-

¹ Value selected from table 1, p. 26.1 of 2009 ASHRAE Handbook – Fundamentals depending on surface orientation

Detail 8.1.18 Exterior Insulated Cross Laminated Timber (CLT) Wall Assembly with Wood Strapping and Continuous Rigid Insulation Supporting Fiber Cement Board

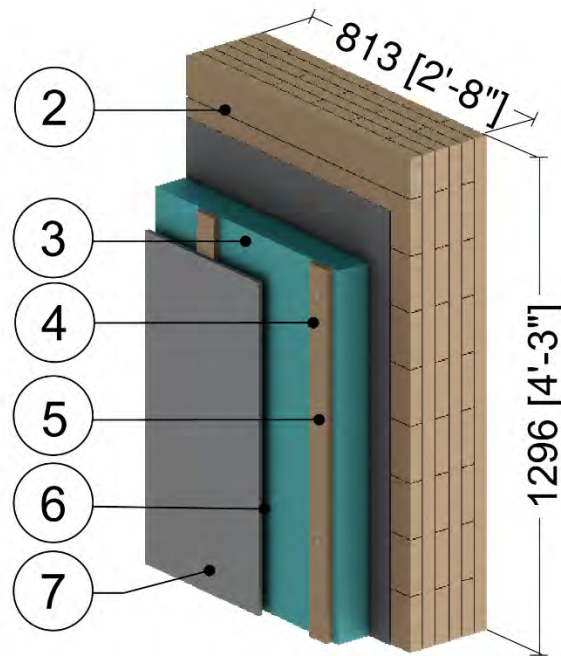

ID	Component	Thickness Inches (mm)	Conductivity Btu·in / ft ² ·hr·°F (W/m K)	Nominal Resistance hr·ft ² ·°F/Btu (m ² K/W)	Density lb/ft ³ (kg/m ³)	Specific Heat Btu/lb·°F (J/kg K)
1	Interior Film ¹	-	-	R-0.7 (0.12 RSI)	-	-
2	Cross Laminated Timber Wall	7 1/2" (191)	0.83 (0.12)	R-9 (1.59 RSI)	31 (500)	0.45 (1880)
3	Exterior Insulation	Varies	-	R-15 to R-25 (2.64 RSI to 4.4 RSI)	1.8 (28)	0.29 (1220)
4	1x3 Wood Strapping (16" o.c.)	3/4" (19)	0.69 (0.10)	-	31 (500)	0.45 (1880)
5	Steel Fasteners (12" o.c.)	0.44" (11) Ø	347 (50)	-	489 (7830)	0.12 (500)
6	Rainscreen Cavity	3/4" (19)	-	R-0.5 (0.09 RSI)	0.075 (1.2)	0.24 (1000)
7	Fiber Cement Board Cladding	1/2" (13)	4.9 (0.7)	R-0.1 (0.02 RSI)	112 (1800)	0.20 (840)
8	Exterior Film ¹	-	-	R-0.2 (0.03 RSI)	-	-

¹ Value selected from table 1, p. 26.1 of 2009 ASHRAE Handbook – Fundamentals depending on surface orientation

Detail 8.1.19 Exterior and Interior Insulated 2x6 Wood Stud (16" o.c.) Wall Assembly with Brick Ties Supporting Brick Veneer and R-19 Batt Insulation in Stud Cavity – Clear Wall

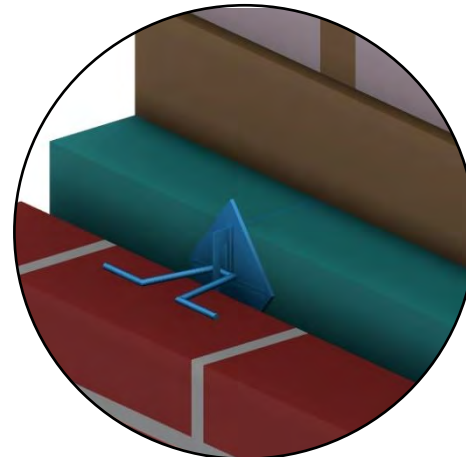
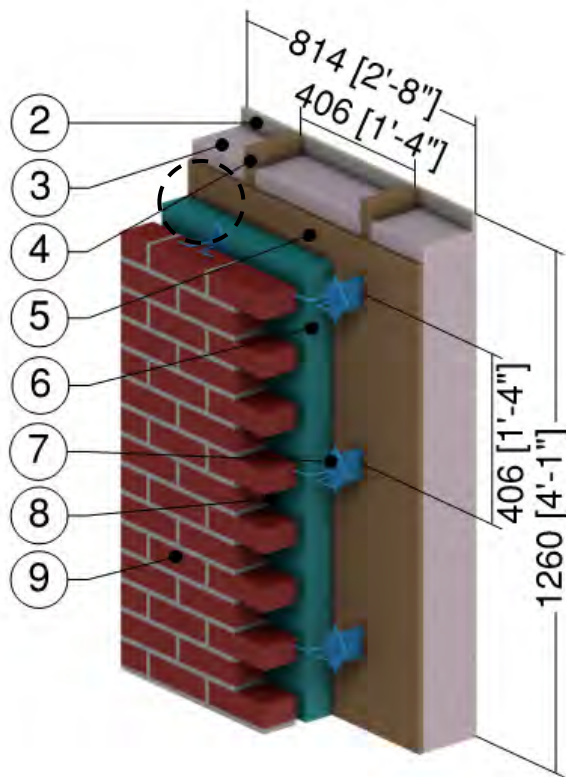

Brick Tie Detail

ID	Component	Thickness Inches (mm)	Conductivity Btu-in / ft ² ·hr·°F (W/m K)	Nominal Resistance hr·ft ² ·°F/Btu (m ² K/W)	Density lb/ft ³ (kg/m ³)	Specific Heat Btu/lb·°F (J/kg K)
1	Interior Film ¹	-	-	R-0.7 (0.12 RSI)	-	-
2	Gypsum Board	1/2" (13)	1.1 (0.16)	R-0.5 (0.08 RSI)	50 (800)	0.26 (1090)
3	Fiberglass Batt Insulation in Stud Cavity	5 1/2" (140)	0.29 (0.042)	R-19 (3.3 RSI)	0.9 (14)	0.17 (710)
4	2x6 Wood Stud (16" o.c.)	5 1/2" (140)	0.69 (0.10)	-	31 (500)	0.45 (1880)
5	Exterior Plywood Sheathing	1/2" (13)	0.69 (0.10)	R-0.7 (0.13 RSI)	31 (500)	0.45 (1880)
6	Exterior Insulation	Varies	-	R-0 to R-15 (0.00 RSI to 2.64 RSI)	1.8 (28)	0.29 (1220)
7	Brick Ties	14 gauge	347 (50)	-	489 (7830)	0.12 (500)
8	Air Cavity	1" (25)	-	R-0.9 (0.16 RSI)	0.075 (1.2)	0.24 (1000)
9	Brick Veneer	3 5/8" (92)	5.4 (0.78)	-	140 (2250)	0.20 (850)
10	Exterior Film ¹	-	-	R-0.2 (0.03 RSI)	-	-

¹ Value selected from table 1, p. 26.1 of 2009 ASHRAE Handbook – Fundamentals depending on surface orientation

Detail 8.1.20

Exterior Insulated 2x6 Wood Stud (16" o.c.) Wall with Interior OSB and Wood Furring Assembly & Brick Ties Supporting Brick Veneer – Clear Wall

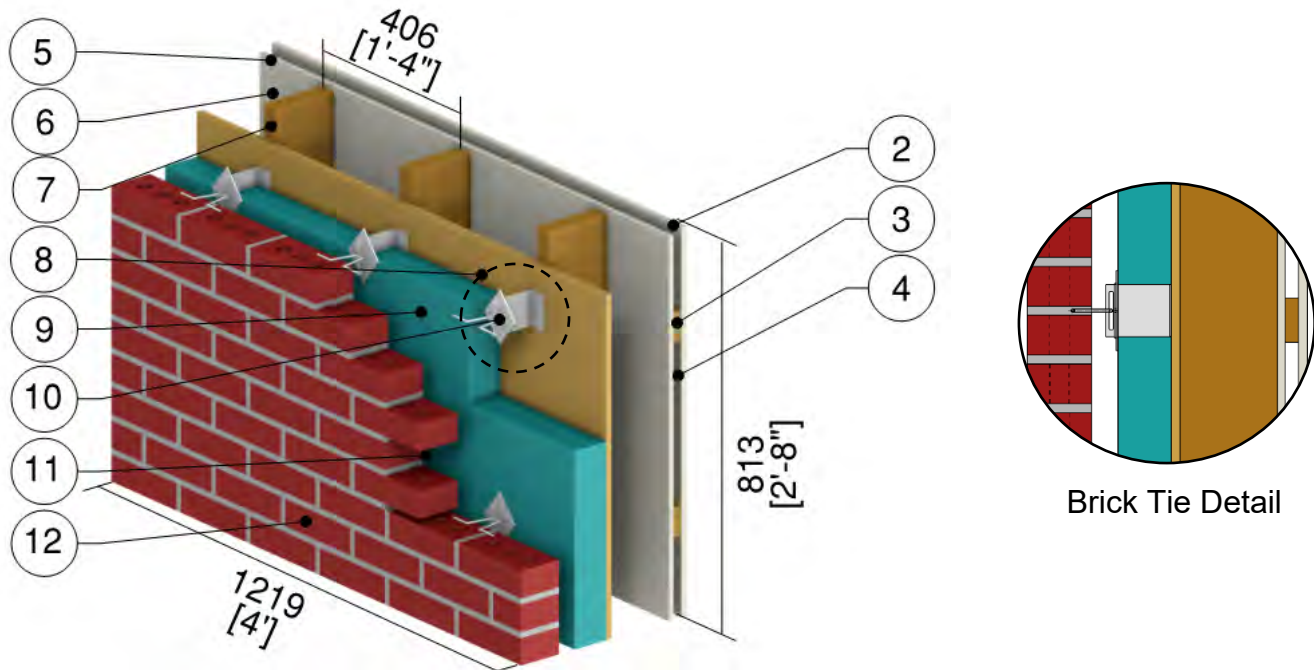

ID	Component	Thickness Inches (mm)	Conductivity Btu-in / ft ² ·hr·°F (W/m K)	Nominal Resistance hr·ft ² ·°F/Btu (m ² K/W)	Density lb/ft ³ (kg/m ³)	Specific Heat Btu/lb·°F (J/kg K)
1	Interior Film ¹	-	-	R-0.7 (0.12 RSI)	-	-
2	Gypsum	1/2" (13)	1.1 (0.16)	R-0.5 (0.08 RSI)	50 (800)	0.26 (1090)
3	1x3 Wood Furring	3/4" (19)	0.69 (0.10)	-	31 (500)	0.45 (1880)
4	Air in Furring Cavity	3/4" (19)	-	R-0.9 (0.16 RSI)	0.075 (1.2)	0.24 (1000)
5	OSB	7/16" (11)	1.1 (0.16)	R-0.4 (0.07 RSI)	31 (500)	0.45 (1880)
6	Air in Stud Cavity	5 1/2" (140)	-	R-0.9 (0.16 RSI)	0.075 (1.2)	0.24 (1000)
7	2x6 Wood Stud (16" o.c.)	5 1/2" (140)	0.69 (0.10)	-	31 (500)	0.45 (1880)
8	Exterior Plywood Sheathing	1/2" (13)	0.69 (0.10)	-	31 (500)	0.45 (1880)
9	Exterior Insulation	Varies	-	R-10 to R-30 (1.76 to 5.28 RSI)	1.8 (28)	0.29 (1220)
10	Brick Ties	14 gauge	347 (50)	-	489 (7830)	0.12 (500)
11	Air Cavity	1 1/2" (38)	-	R-0.4 (0.07 RSI)	0.075 (1.2)	0.24 (1000)
12	Brick Veneer	3 5/8" (92)	5.4 (0.78)	R-0.7 (0.12 RSI)	140 (2250)	0.20 (850)
13	Exterior Film ¹	-	-	R-0.2 (0.03 RSI)	-	-

¹ Value selected from table 1, p. 26.1 of 2009 ASHRAE Handbook – Fundamentals depending on surface orientation

Detail 8.1.21

Exterior and Interior Insulated 2x6 Wood Stud (16" o.c.) Wall with Interior OSB and Wood Furring Assembly & Brick Ties Supporting Brick Veneer – Clear Wall

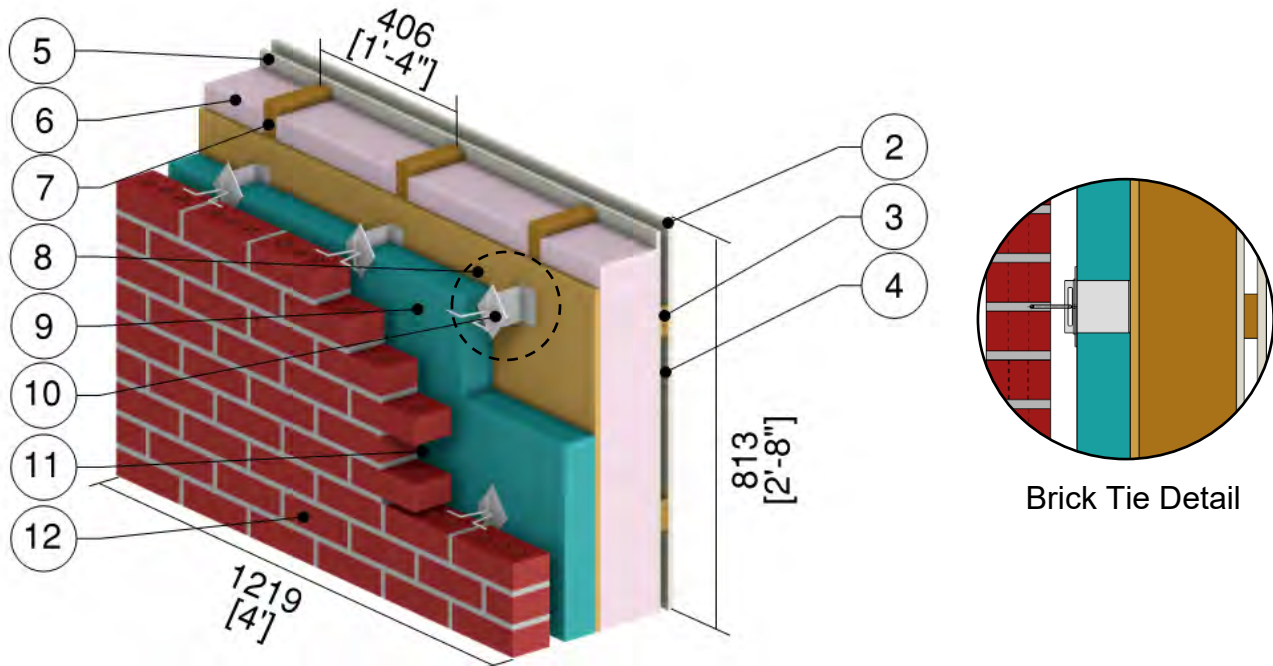

ID	Component	Thickness Inches (mm)	Conductivity Btu-in / ft ² -hr-°F (W/m K)	Nominal Resistance hr-ft ² -°F/Btu (m ² K/W)	Density lb/ft ³ (kg/m ³)	Specific Heat Btu/lb-°F (J/kg K)
1	Interior Film ¹	-	-	R-0.7 (0.12 RSI)	-	-
2	Gypsum	1/2" (13)	1.1 (0.16)	R-0.5 (0.08 RSI)	50 (800)	0.26 (1090)
3	1x3 Wood Furring	3/4" (19)	0.69 (0.10)	-	31 (500)	0.45 (1880)
4	Air in Furring Cavity	3/4" (19)	-	R-0.9 (0.16 RSI)	0.075 (1.2)	0.24 (1000)
5	OSB	7/16" (11)	1.1 (0.16)	R-0.4 (0.07 RSI)	31 (500)	0.45 (1880)
6	Fiberglass Batt Insulation in Stud Cavity	5 1/2" (140)	0.29 (0.042)	R-19.0 (3.35 RSI)	0.9 (14)	0.17 (710)
7	2x6 Wood Stud (16" o.c.)	5 1/2" (140)	0.69 (0.10)	-	31 (500)	0.45 (1880)
8	Exterior Plywood Sheathing	1/2" (13)	0.69 (0.10)	-	31 (500)	0.45 (1880)
9	Exterior Insulation	Varies	-	R-5 to R-30 (0.88 to 5.28 RSI)	1.8 (28)	0.29 (1220)
10	Brick Ties	14 gauge	347 (50)	-	489 (7830)	0.12 (500)
11	Air Cavity	1 1/2" (38)	-	R-0.4 (0.07 RSI)	0.075 (1.2)	0.24 (1000)
12	Brick Veneer	3 5/8" (92)	5.4 (0.78)	R-0.7 (0.12 RSI)	140 (2250)	0.20 (850)
13	Exterior Film ¹	-	-	R-0.2 (0.03 RSI)	-	-

¹ Value selected from table 1, p. 26.1 of 2009 ASHRAE Handbook – Fundamentals depending on surface orientation

Detail 8.1.22

Exterior Insulated 2x6 Wood Stud (16" o.c.) Wall with Interior Wood Furring Assembly & Brick Ties Supporting Brick Veneer – Clear Wall

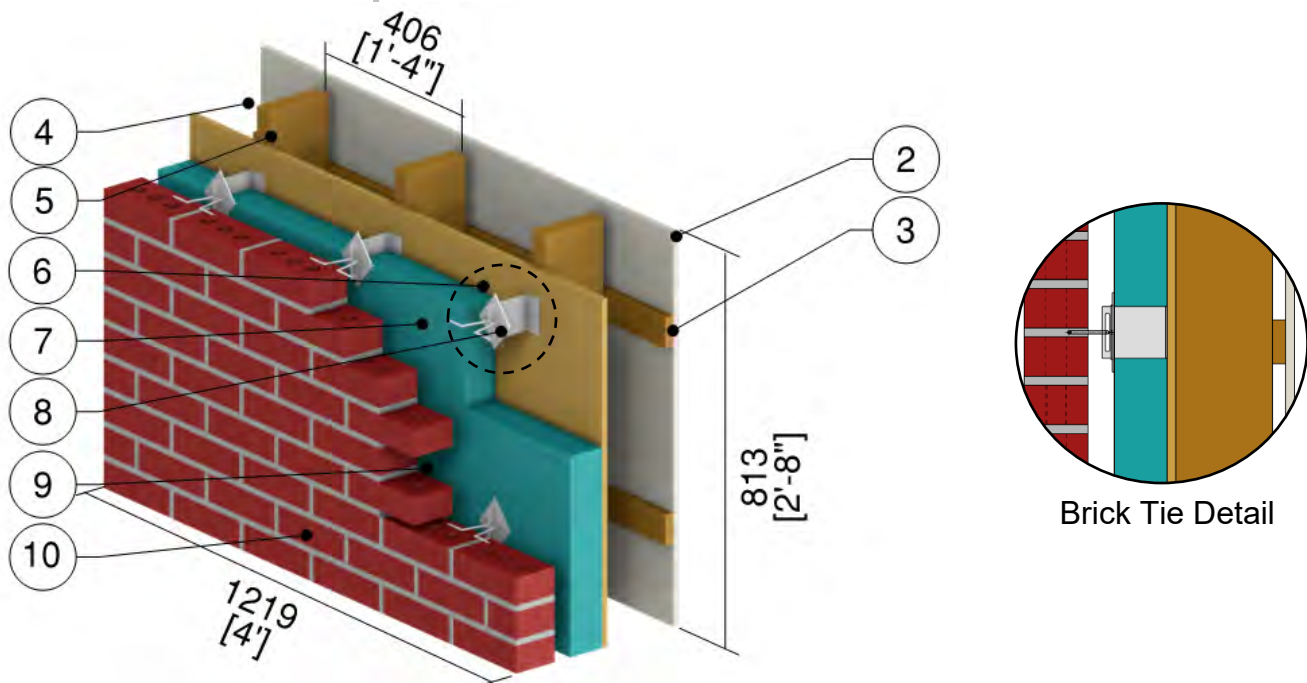

ID	Component	Thickness Inches (mm)	Conductivity Btu-in / ft ² -hr-°F (W/m K)	Nominal Resistance hr-ft ² -°F/Btu (m ² K/W)	Density lb/ft ³ (kg/m ³)	Specific Heat Btu/lb-°F (J/kg K)
1	Interior Film ¹	-	-	R-0.7 (0.12 RSI)	-	-
2	Gypsum	1/2" (13)	1.1 (0.16)	R-0.5 (0.08 RSI)	50 (800)	0.26 (1090)
3	1x3 Wood Furring	3/4" (19)	0.69 (0.10)	-	31 (500)	0.45 (1880)
4	Air in Stud Cavity	6 1/4" (159)	-	R-0.9 (0.16 RSI)	0.075 (1.2)	0.24 (1000)
5	2x6 Wood Stud (16" o.c.)	5 1/2" (140)	0.69 (0.10)	-	31 (500)	0.45 (1880)
6	Exterior Plywood Sheathing	1/2" (13)	0.69 (0.10)	-	31 (500)	0.45 (1880)
7	Exterior Insulation	Varies	-	R-10 to R-30 (1.76 to 5.28 RSI)	1.8 (28)	0.29 (1220)
8	Brick Ties	14 gauge	347 (50)	-	489 (7830)	0.12 (500)
9	Air Cavity	1 1/2" (38)	-	R-0.4 (0.07 RSI)	0.075 (1.2)	0.24 (1000)
10	Brick Veneer	3 5/8" (92)	5.4 (0.78)	R-0.7 (0.12 RSI)	140 (2250)	0.20 (850)
11	Exterior Film ¹	-	-	R-0.2 (0.03 RSI)	-	-

¹ Value selected from table 1, p. 26.1 of 2009 ASHRAE Handbook – Fundamentals depending on surface orientation

Detail 8.1.23

Exterior and Interior Insulated 2x6 Wood Stud (16" o.c.) Wall with Interior Wood Furring Assembly & Brick Ties Supporting Brick Veneer – Clear Wall

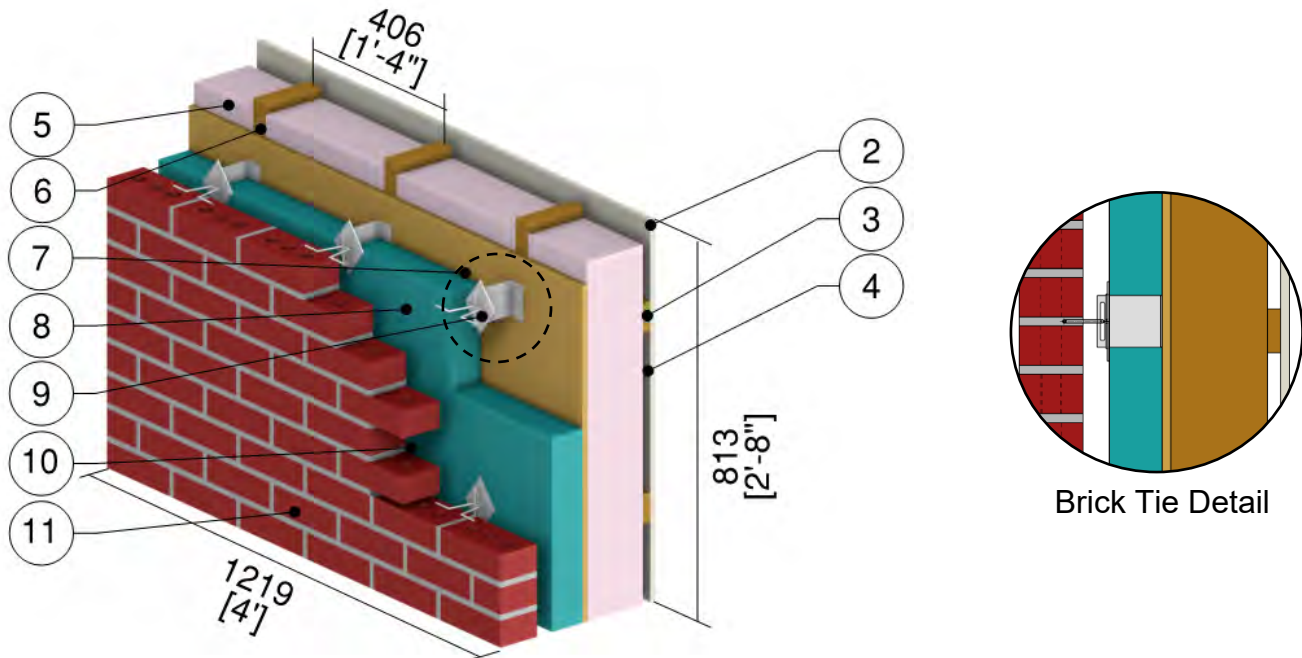

ID	Component	Thickness Inches (mm)	Conductivity Btu-in / ft ² ·hr·°F (W/m K)	Nominal Resistance hr·ft ² ·°F/Btu (m ² K/W)	Density lb/ft ³ (kg/m ³)	Specific Heat Btu/lb·°F (J/kg K)
1	Interior Film ¹	-	-	R-0.7 (0.12 RSI)	-	-
2	Gypsum	1/2" (13)	1.1 (0.16)	R-0.5 (0.08 RSI)	50 (800)	0.26 (1090)
3	1x3 Wood Furring	3/4" (19)	0.69 (0.10)	-	31 (500)	0.45 (1880)
4	Air in Furring Cavity	3/4" (19)	-	R-0.9 (0.16 RSI)	0.075 (1.2)	0.24 (1000)
5	Fiberglass Batt Insulation in Stud Cavity	5 1/2" (140)	0.29 (0.042)	R-19.0 (3.35 RSI)	0.9 (14)	0.17 (710)
6	2x6 Wood Stud (16" o.c.)	5 1/2" (140)	0.69 (0.10)	-	31 (500)	0.45 (1880)
7	Exterior Plywood Sheathing	1/2" (13)	0.69 (0.10)	-	31 (500)	0.45 (1880)
8	Exterior Insulation	Varies	-	R-5 to R-30 (0.88 to 5.28 RSI)	1.8 (28)	0.29 (1220)
9	Brick Ties	14 gauge	347 (50)	-	489 (7830)	0.12 (500)
10	Air Cavity	1 1/2" (38)	-	R-0.4 (0.07 RSI)	0.075 (1.2)	0.24 (1000)
11	Brick Veneer	3 5/8" (92)	5.4 (0.78)	R-0.7 (0.12 RSI)	140 (2250)	0.20 (850)
12	Exterior Film ¹	-	-	R-0.2 (0.03 RSI)	-	-

¹ Value selected from table 1, p. 26.1 of 2009 ASHRAE Handbook – Fundamentals depending on surface orientation

Detail 8.1.24

Interior Insulated Double Framed Wall 2x6 and 2x4 Wood Stud (16" o.c.) Wall Assembly with 1" Gap – Clear Wall

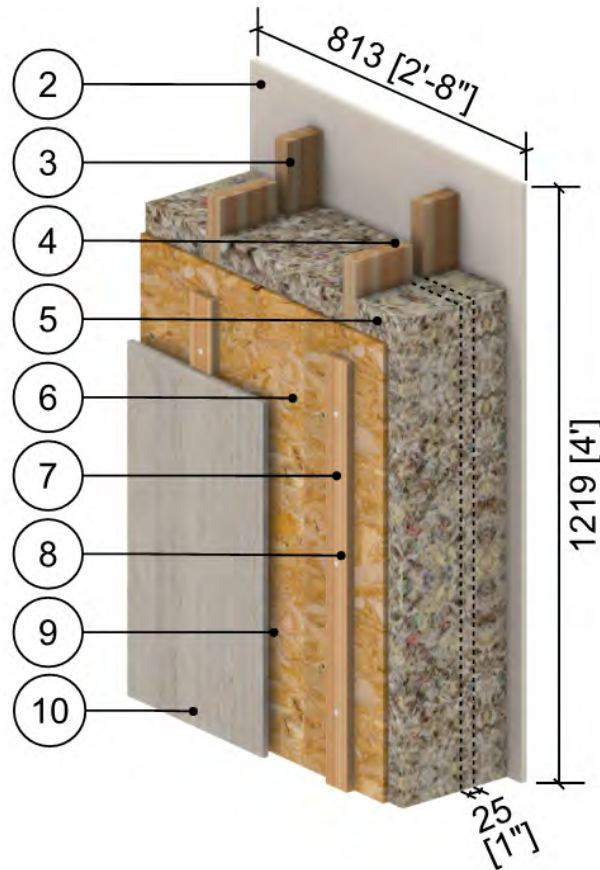

ID	Component	Thickness Inches (mm)	Conductivity Btu-in / ft ² -hr-°F (W/m K)	Nominal Resistance hr-ft ² -°F/Btu (m ² K/W)	Density lb/ft ³ (kg/m ³)	Specific Heat Btu/lb-°F (J/kg K)
1	Interior Film ¹	-	-	R-0.7 (0.12 RSI)	-	-
2	Gypsum Board	1/2" (13)	1.1 (0.16)	R-0.5 (0.08 RSI)	50 (800)	0.26 (1090)
3	Fill Insulation	10" (305)	Varies	R-35.0 to R-60.0 (6.16 RSI to 10.57 RSI)	-	-
4	2x4 Wood Stud (16" o.c.)	3 1/2" (89)	0.69 (0.10)	-	31 (500)	0.45 (1880)
5	2x6 Wood Stud (16" o.c.)	5 1/2" (140)	0.69 (0.10)	-	31 (500)	0.45 (1880)
6	Exterior Plywood Sheathing	1/2" (13)	0.69 (0.10)	R-0.7 (0.13 RSI)	31 (500)	0.45 (1880)
7	Wood Strapping (1" x 3")	3/4" (19)	0.69 (0.10)	-	31 (500)	0.45 (1880)
8	Steel Fasteners (12" o.c.)	0.43" (11) Ø	347 (50)	-	489 (7830)	0.12 (500)
9	Rainscreen Cavity	3/4" (19)	-	R-0.4 (0.07 RSI)	0.075 (1.2)	0.24 (1000)
10	Fiber Cement Board	1/2" (13)	4.86 (0.7)	R-0.1 (0.02 RSI)	-	-
11	Exterior Film ¹	-	-	R-0.2 (0.03 RSI)	-	-

¹ Value selected from table 1, p. 26.1 of 2009 ASHRAE Handbook – Fundamentals depending on surface orientation

Detail 8.1.25

Exterior and Interior Insulated 2x6 Wood Stud (16" o.c.) Wall Assembly with SOPREMA SOPRA-XPS 20 and ACS-S Thermal Clip Supporting Metal Cladding with R-19 Cellulose Insulation in Stud Cavity - Clear Wall

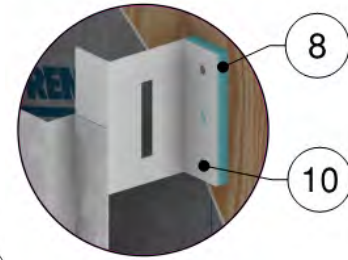
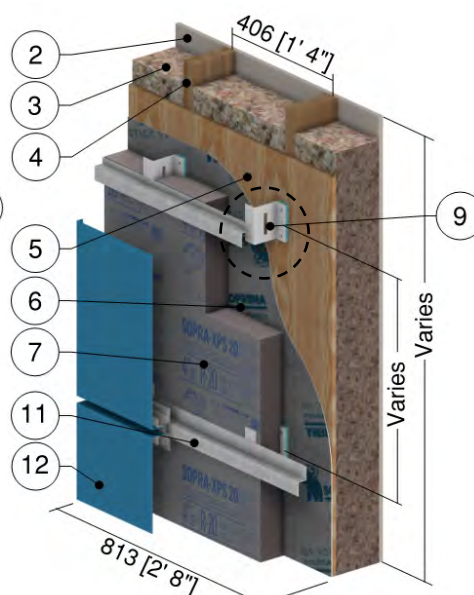
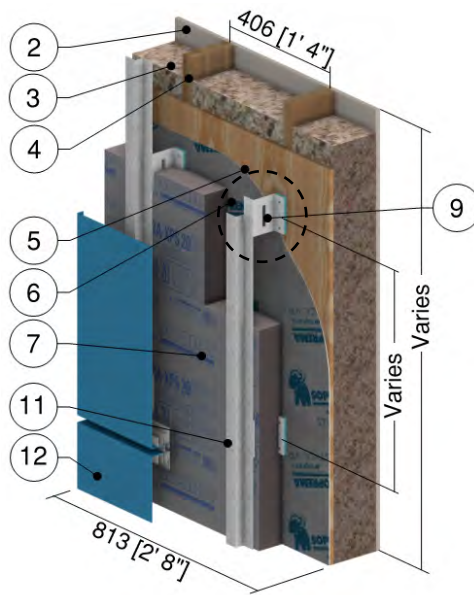

Vertical Girt: ACS Clip Detail

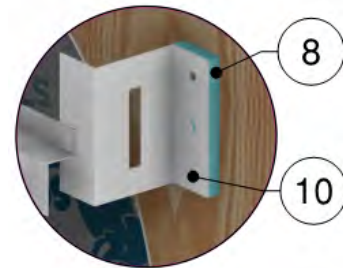

Horizontal Girt: ACS Clip Detail

ID	Component	Thickness Inches (mm)	Conductivity Btu-in / ft ² -hr-°F (W/m K)	Nominal Resistance hr-ft ² -°F/Btu (m ² K/W)	Density lb/ft ³ (kg/m ³)	Specific Heat Btu/lb-°F (J/kg K)
1	Interior Film ¹	-	-	R-0.7 (0.12 RSI)	-	-
2	Gypsum Board	1/2" (13)	1.1 (0.16)	R-0.5 (0.09 RSI)	50 (800)	0.26 (1090)
3	Cellulose Insulation in Stud Cavity	5-1/2" (140)	0.29 (0.042)	R-19.0 (3.35 RSI)	1.2 (19)	0.33 (1400)
4	2x6 Wood Stud	5-1/2" (140)	0.69 (0.10)	-	31 (500)	0.45 (1880)
5	Exterior Plywood Sheathing	1/2" (13)	0.69 (0.10)	R-0.7 (0.13 RSI)	31 (500)	0.45 (1880)
6	SOPREMA SOPRASEAL STICK VP membrane	-	-	-	-	-
7	SOPRA-XPS 20 Exterior Insulation	Varies	0.20 (0.029)	R-5.0 to R-35.0 (0.88 to RSI 6.16 RSI)	2.5 (40)	0.29 (1220)
8	Thermal Break	1/2" (13)	0.13 (0.019)	-	2.1 (33)	0.50 (2100)
9	ACS-S Thermal Clip	16 Gauge	118 (17)	-	500 (8000)	0.13 (530)
10	Fastener	1/4" (6.4) Ø	347 (50)	-	489 (7830)	0.12 (500)
11	Girt	18 Gauge	430 (62)	-	489 (7830)	0.12 (500)
12	Cladding with 1/2" vented airspace incorporated into exterior heat transfer coefficient					
13	Exterior Film ¹	-	-	R-0.7 (0.12 RSI)	-	-

¹ Value selected from table 1, p. 26.1 of 2009 ASHRAE Handbook – Fundamentals depending on surface orientation

Detail 8.1.26

Exterior and Interior Insulated 2x6 Wood Stud (24" o.c.) Wall Assembly with SOPREMA SOPRA-XPS 20 and ACS-S Thermal Clip Supporting Metal Cladding with R-19 Cellulose Insulation in Stud Cavity - Clear Wall

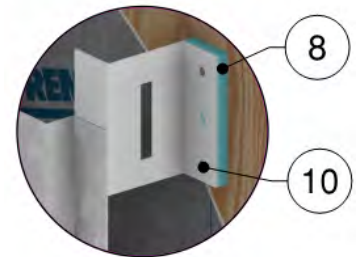
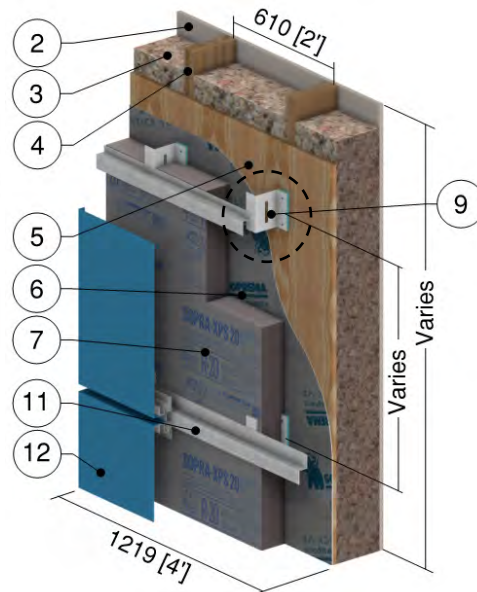
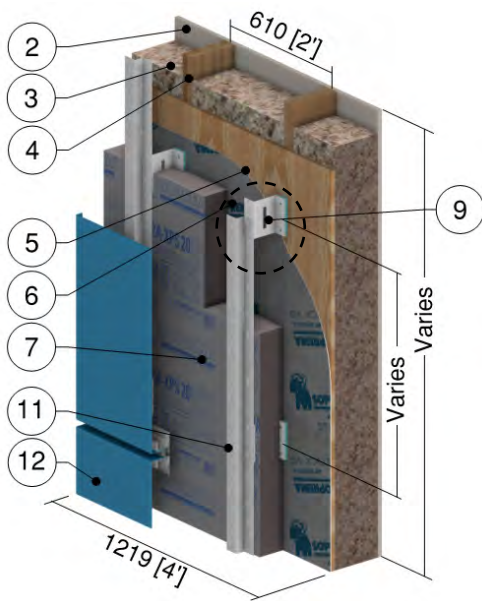

Vertical Girt: ACS Clip Detail

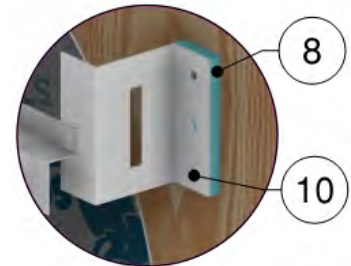

Horizontal Girt: ACS Clip Detail

ID	Component	Thickness Inches (mm)	Conductivity Btu-in / ft ² -hr-°F (W/m K)	Nominal Resistance hr-ft ² -°F/Btu (m ² K/W)	Density lb/ft ³ (kg/m ³)	Specific Heat Btu/lb-°F (J/kg K)
1	Interior Film ¹	-	-	R-0.7 (0.12 RSI)	-	-
2	Gypsum Board	1/2" (13)	1.1 (0.16)	R-0.5 (0.09 RSI)	50 (800)	0.26 (1090)
3	Cellulose Insulation in Stud Cavity	5-1/2" (140)	0.29 (0.042)	R-19.0 (3.35 RSI)	1.2 (19)	0.33 (1400)
4	2x6 Wood Stud	5-1/2" (140)	0.69 (0.10)	-	31 (500)	0.45 (1880)
5	Exterior Plywood Sheathing	1/2" (13)	0.69 (0.10)	R-0.7 (0.13 RSI)	31 (500)	0.45 (1880)
6	SOPREMA SOPRASEAL STICK VP membrane	-	-	-	-	-
7	SOPRA-XPS 20 Exterior Insulation	Varies	0.20 (0.029)	R-5.0 to R-35.0 (0.88 RSI to 6.16 RSI)	2.5 (40)	0.29 (1220)
8	Thermal Break	1/2" (13)	0.13 (0.019)	-	2.1 (33)	0.50 (2100)
9	ACS-S Thermal Clip	16 Gauge	118 (17)	-	500 (8000)	0.13 (530)
10	Fastener	1/4" (6.4) Ø	347 (50)	-	489 (7830)	0.12 (500)
11	Girt	18 Gauge	430 (62)	-	489 (7830)	0.12 (500)
12	Cladding with 1/2" vented airspace incorporated into exterior heat transfer coefficient					
13	Exterior Film ¹	-	-	R-0.7 (0.12 RSI)	-	-

¹ Value selected from table 1, p. 26.1 of 2009 ASHRAE Handbook – Fundamentals depending on surface orientation

Detail 8.1.27

Exterior and Interior Insulated 2x6 Wood Stud (16" o.c.) Wall Assembly with SOPREMA SOPRA-SPF 202 and ACS-S Thermal Clip Supporting Metal Cladding with R-19 Cellulose Insulation in Stud Cavity - Clear Wall

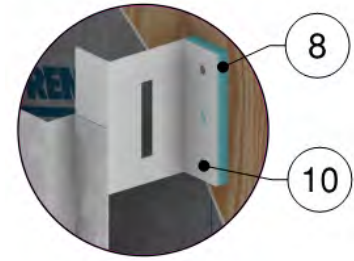
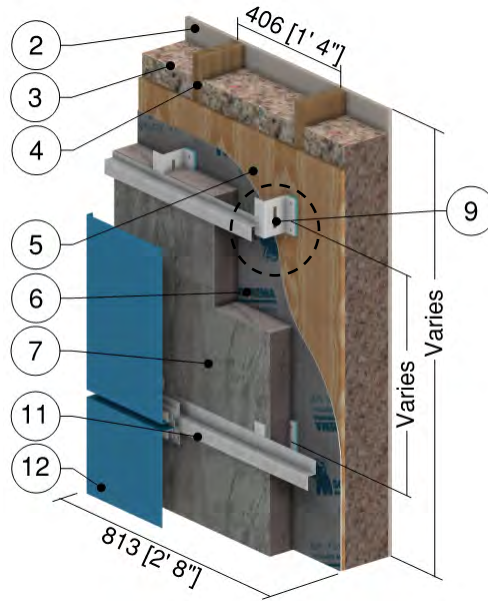
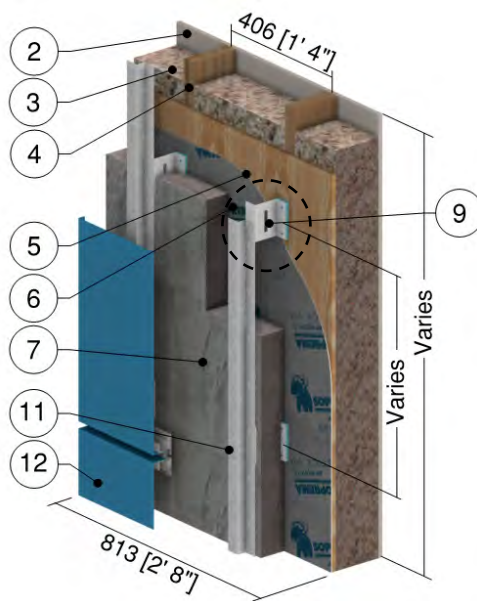

Vertical Girt: ACS Clip Detail

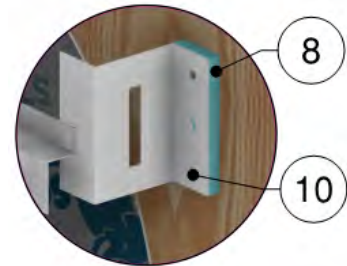

Horizontal Girt: ACS Clip Detail

ID	Component	Thickness Inches (mm)	Conductivity Btu-in / ft ² ·hr·°F (W/m K)	Nominal Resistance hr·ft ² ·°F/Btu (m ² K/W)	Density lb/ft ³ (kg/m ³)	Specific Heat Btu/lb·°F (J/kg K)
1	Interior Film ¹	-	-	R-0.7 (0.12 RSI)	-	-
2	Gypsum Board	1/2" (13)	1.1 (0.16)	R-0.5 (0.09 RSI)	50 (800)	0.26 (1090)
3	Cellulose Insulation in Stud Cavity	5-1/2" (140)	0.29 (0.042)	R-19.0 (3.35 RSI)	1.2 (19)	0.33 (1400)
4	2x6 Wood Stud	5-1/2" (140)	0.69 (0.10)	-	31 (500)	0.45 (1880)
5	Exterior Plywood Sheathing	1/2" (13)	0.69 (0.10)	R-0.7 (0.13 RSI)	31 (500)	0.45 (1880)
6	SOPREMA SOPRASEAL STICK VP membrane	-	-	-	-	-
7	SOPRA-SPF 202 Exterior Insulation	Varies	0.16 (0.023)	R-6.2 to R-43.4 (1.09 RSI to 7.64 RSI)	1.8 (28)	0.29 (1220)
8	Thermal Break	1/2" (13)	0.13 (0.019)	-	2.1 (33)	0.50 (2100)
9	ACS-S Thermal Clip	16 Gauge	118 (17)	-	500 (8000)	0.13 (530)
10	Fastener	1/4" (6.4) Ø	347 (50)	-	489 (7830)	0.12 (500)
11	Girt	18 Gauge	430 (62)	-	489 (7830)	0.12 (500)
12	Cladding with 1/2" vented airspace incorporated into exterior heat transfer coefficient					
13	Exterior Film ¹	-	-	R-0.7 (0.12 RSI)	-	-

¹ Value selected from table 1, p. 26.1 of 2009 ASHRAE Handbook – Fundamentals depending on surface orientation

Detail 8.1.28

Exterior and Interior Insulated 2x6 Wood Stud (24" o.c.) Wall Assembly with SOPREMA SOPRA-SPF 202 and ACS-S Thermal Clip Supporting Metal Cladding with R-19 Cellulose Insulation in Stud Cavity - Clear Wall

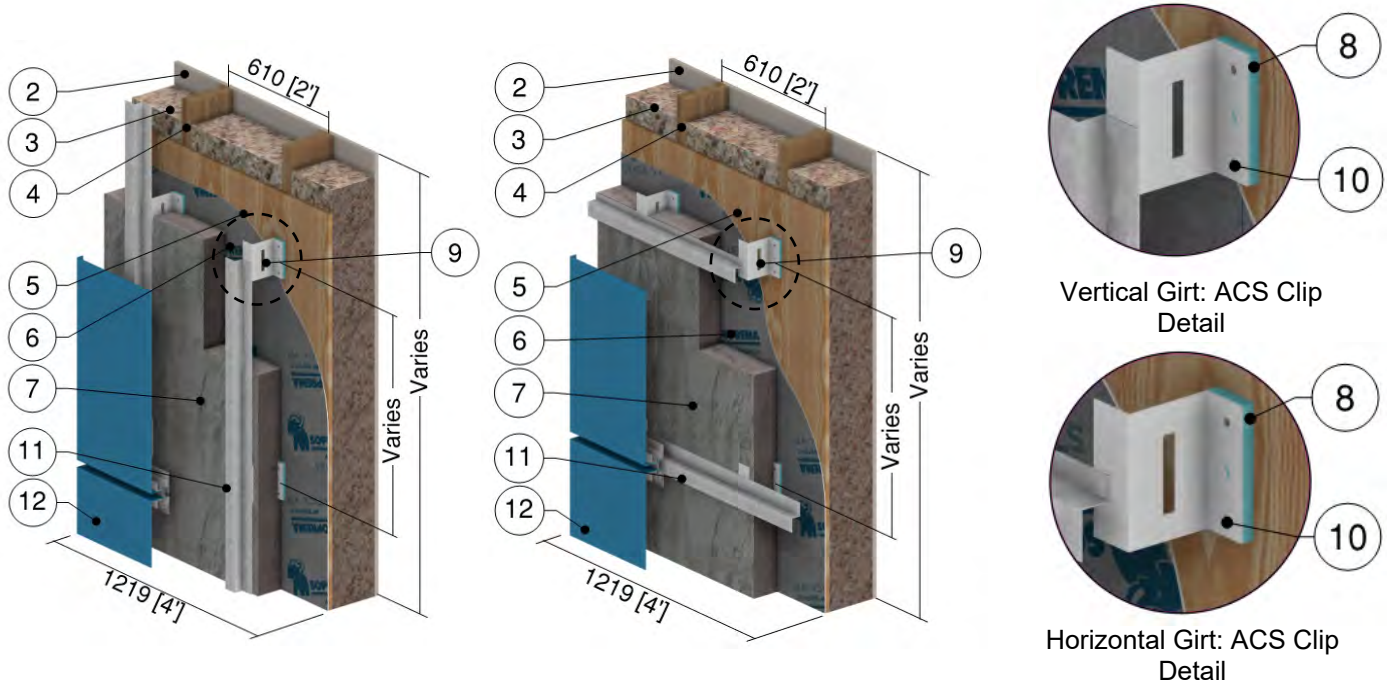

ID	Component	Thickness Inches (mm)	Conductivity Btu-in / ft ² ·hr·°F (W/m K)	Nominal Resistance hr·ft ² ·°F/Btu (m ² K/W)	Density lb/ft ³ (kg/m ³)	Specific Heat Btu/lb·°F (J/kg K)
1	Interior Film ¹	-	-	R-0.7 (0.12 RSI)	-	-
2	Gypsum Board	1/2" (13)	1.1 (0.16)	R-0.5 (0.09 RSI)	50 (800)	0.26 (1090)
3	Cellulose Insulation in Stud Cavity	5-1/2" (140)	0.29 (0.042)	R-19.0 (3.35 RSI)	1.2 (19)	0.33 (1400)
4	2x6 Wood Stud	5-1/2" (140)	0.69 (0.10)	-	31 (500)	0.45 (1880)
5	Exterior Plywood Sheathing	1/2" (13)	0.69 (0.10)	R-0.7 (0.13 RSI)	31 (500)	0.45 (1880)
6	SOPREMA SOPRASEAL STICK VP membrane	-	-	-	-	-
7	SOPRA-SPF 202 Exterior Insulation	Varies	0.16 (0.023)	R-6.2 to R-43.4 (1.09 RSI to 7.64 RSI)	1.8 (28)	0.29 (1220)
8	Thermal Break	1/2" (13)	0.13 (0.019)	-	2.1 (33)	0.50 (2100)
9	ACS-S Thermal Clip	16 Gauge	118 (17)	-	500 (8000)	0.13 (530)
10	Fastener	1/4" (6.4) Ø	347 (50)	-	489 (7830)	0.12 (500)
11	Girt	18 Gauge	430 (62)	-	489 (7830)	0.12 (500)
12	Cladding with 1/2" vented airspace incorporated into exterior heat transfer coefficient					
13	Exterior Film ¹	-	-	R-0.7 (0.12 RSI)	-	-

¹ Value selected from table 1, p. 26.1 of 2009 ASHRAE Handbook – Fundamentals depending on surface orientation

Detail 8.1.29

Exterior and Interior Insulated 2x6 Wood Stud (16" o.c.) Wall Assembly with SOPREMA SOPRA-ISO V PLUS and ACS-S Thermal Clip Supporting Metal Cladding with R-19 Cellulose Insulation in Stud Cavity - Clear Wall

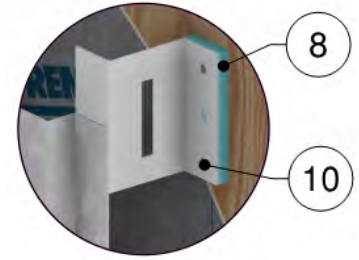
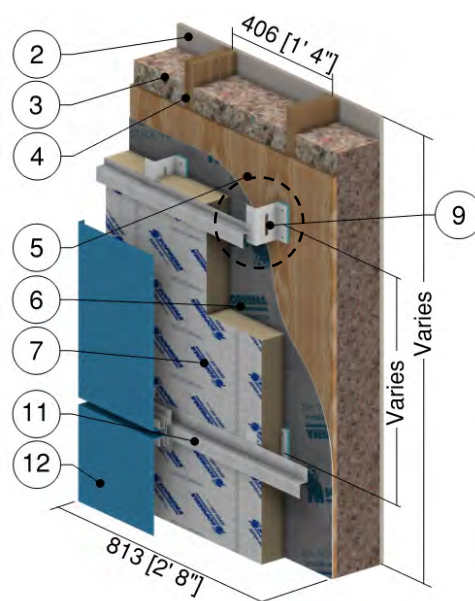
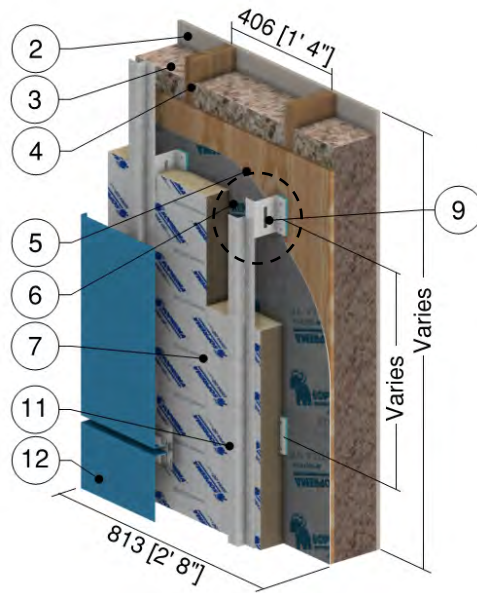

Vertical Girt: ACS Clip Detail

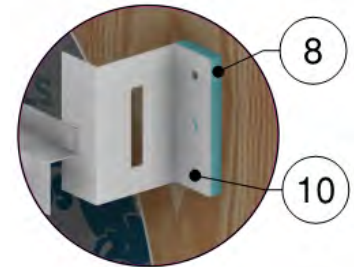

Horizontal Girt: ACS Clip Detail

ID	Component	Thickness Inches (mm)	Conductivity Btu-in / ft ² -hr-°F (W/m K)	Nominal Resistance hr-ft ² -°F/Btu (m ² K/W)	Density lb/ft ³ (kg/m ³)	Specific Heat Btu/lb-°F (J/kg K)
1	Interior Film ¹	-	-	R-0.7 (0.12 RSI)	-	-
2	Gypsum Board	1/2" (13)	1.1 (0.16)	R-0.5 (0.09 RSI)	50 (800)	0.26 (1090)
3	Cellulose Insulation in Stud Cavity	5-1/2" (140)	0.29 (0.042)	R-19.0 (3.35 RSI)	1.2 (19)	0.33 (1400)
4	2x6 Wood Stud	5-1/2" (140)	0.69 (0.10)	-	31 (500)	0.45 (1880)
5	Exterior Plywood Sheathing	1/2" (13)	0.69 (0.10)	R-0.7 (0.13 RSI)	31 (500)	0.45 (1880)
6	SOPREMA SOPRASEAL STICK VP membrane	-	-	-	-	-
7	SOPRA-ISO V PLUS Exterior Insulation	Varies	0.17 (0.024)	R-6.0 to R-42.0 (1.06 RSI to 7.40 RSI)	1.9 (30)	0.36 (1500)
8	Thermal Break	1/2" (13)	0.13 (0.019)	-	2.1 (33)	0.50 (2100)
9	ACS-S Thermal Clip	16 Gauge	118 (17)	-	500 (8000)	0.13 (530)
10	Fastener	1/4" (6.4) Ø	347 (50)	-	489 (7830)	0.12 (500)
11	Girt	18 Gauge	430 (62)	-	489 (7830)	0.12 (500)
12	Cladding with 1/2" vented airspace incorporated into exterior heat transfer coefficient					
13	Exterior Film ¹	-	-	R-0.7 (0.12 RSI)	-	-

¹ Value selected from table 1, p. 26.1 of 2009 ASHRAE Handbook – Fundamentals depending on surface orientation

Detail 8.1.30

Exterior and Interior Insulated 2x6 Wood Stud (24" o.c.) Wall Assembly with SOPREMA SOPRA-ISO V PLUS and ACS-S Thermal Clip Supporting Metal Cladding with R-19 Cellulose Insulation in Stud Cavity - Clear Wall

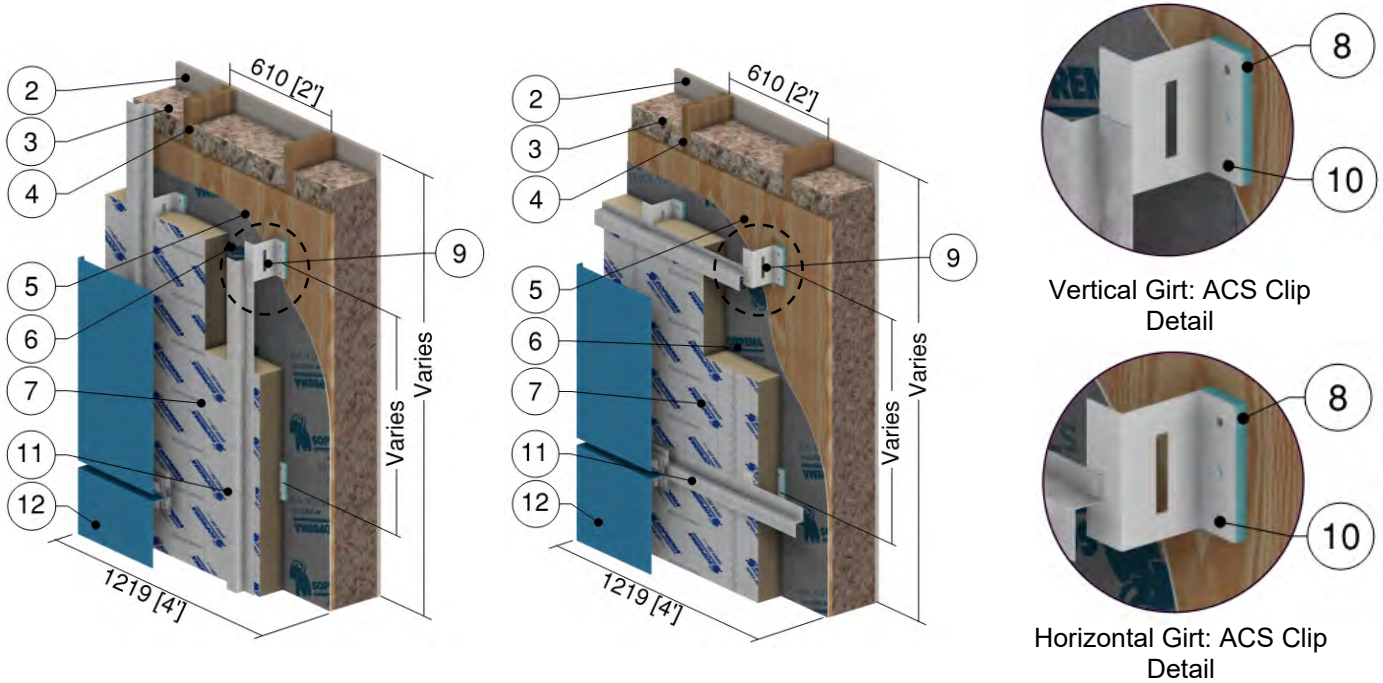

ID	Component	Thickness Inches (mm)	Conductivity Btu-in / ft ² -hr-°F (W/m K)	Nominal Resistance hr-ft ² -°F/Btu (m ² K/W)	Density lb/ft ³ (kg/m ³)	Specific Heat Btu/lb-°F (J/kg K)
1	Interior Film ¹	-	-	R-0.7 (0.12 RSI)	-	-
2	Gypsum Board	1/2" (13)	1.1 (0.16)	R-0.5 (0.09 RSI)	50 (800)	0.26 (1090)
3	Cellulose Insulation in Stud Cavity	5-1/2" (140)	0.29 (0.042)	R-19.0 (3.35 RSI)	1.2 (19)	0.33 (1400)
4	2x6 Wood Stud	5-1/2" (140)	0.69 (0.10)	-	31 (500)	0.45 (1880)
5	Exterior Plywood Sheathing	1/2" (13)	0.69 (0.10)	R-0.7 (0.13 RSI)	31 (500)	0.45 (1880)
6	SOPREMA SOPRASEAL STICK VP membrane	-	-	-	-	-
7	SOPRA-ISO V PLUS Exterior Insulation	Varies	0.17 (0.024)	R-6.0 to R-42.0 (1.06 RSI to 7.40 RSI)	1.9 (30)	0.36 (1500)
8	Thermal Break	1/2" (13)	0.13 (0.019)	-	2.1 (33)	0.50 (2100)
9	ACS-S Thermal Clip	16 Gauge	118 (17)	-	500 (8000)	0.13 (530)
10	Fastener	1/4" (6.4) Ø	347 (50)	-	489 (7830)	0.12 (500)
11	Girt	18 Gauge	430 (62)	-	489 (7830)	0.12 (500)
12	Cladding with 1/2" vented airspace incorporated into exterior heat transfer coefficient					
13	Exterior Film ¹	-	-	R-0.7 (0.12 RSI)	-	-

¹ Value selected from table 1, p. 26.1 of 2009 ASHRAE Handbook – Fundamentals depending on surface orientation

Detail 8.1.31

Exterior and Interior Insulated 2x6 Wood Stud (16" o.c.) Wall Assembly with Mineral Wool and ACS-S Thermal Clip Supporting Metal Cladding with R-19 Cellulose Insulation in Stud Cavity - Clear Wall

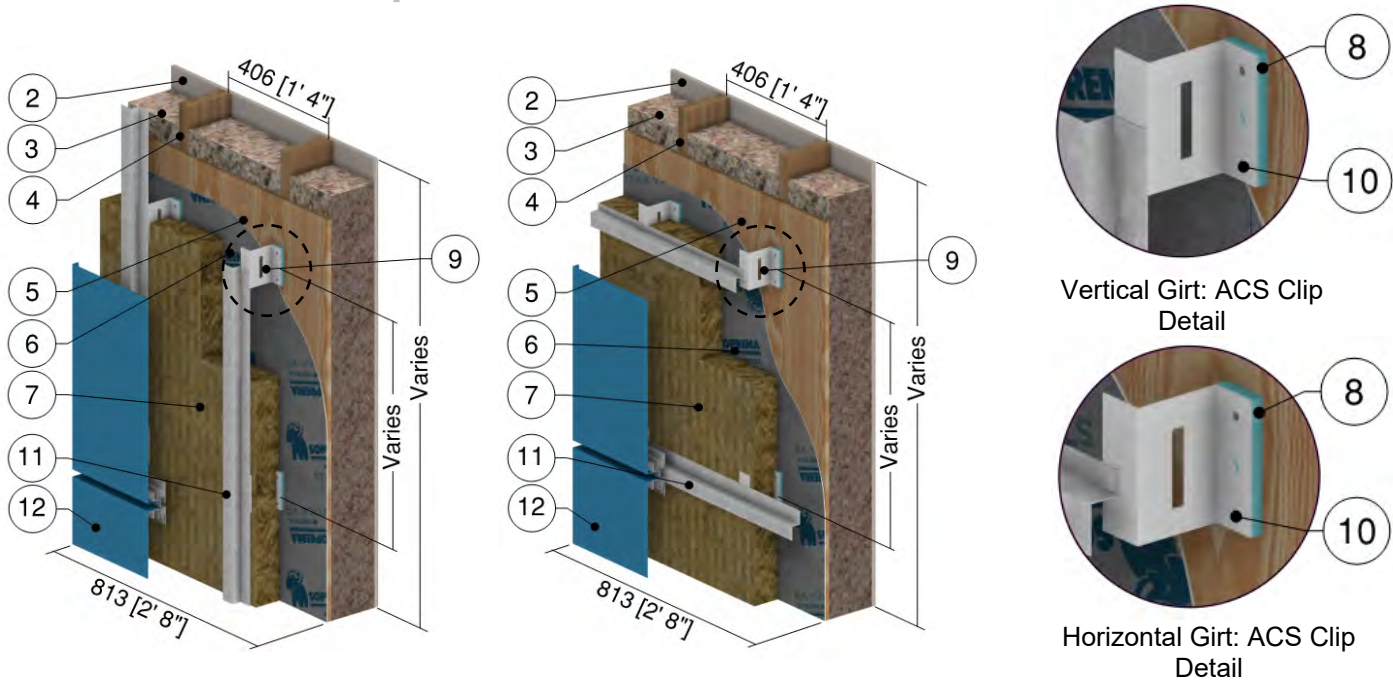

ID	Component	Thickness Inches (mm)	Conductivity Btu-in / ft ² ·hr·°F (W/m K)	Nominal Resistance hr·ft ² ·°F/Btu (m ² K/W)	Density lb/ft ³ (kg/m ³)	Specific Heat Btu/lb·°F (J/kg K)
1	Interior Film ¹	-	-	R-0.7 (0.12 RSI)	-	-
2	Gypsum Board	1/2" (13)	1.1 (0.16)	R-0.5 (0.09 RSI)	50 (800)	0.26 (1090)
3	Cellulose Insulation in Stud Cavity	5-1/2" (140)	0.29 (0.042)	R-19.0 (3.35 RSI)	1.2 (19)	0.33 (1400)
4	2x6 Wood Stud	5-1/2" (140)	0.69 (0.10)	-	31 (500)	0.45 (1880)
5	Exterior Plywood Sheathing	1/2" (13)	0.69 (0.10)	R-0.7 (0.13 RSI)	31 (500)	0.45 (1880)
6	SOPREMA SOPRASEAL STICK VP membrane	-	-	-	-	-
7	Exterior Mineral Wool Insulation	Varies	0.23 (0.034)	R-4.3 to R-34.4 (0.76 RSI to 6.06 RSI)	1.8 (28)	0.29 (1220)
8	Thermal Break	1/2" (13)	0.13 (0.019)	-	2.1 (33)	0.50 (2100)
9	ACS-S Thermal Clip	16 Gauge	118 (17)	-	500 (8000)	0.13 (530)
10	Fastener	1/4" (6.4) Ø	347 (50)	-	489 (7830)	0.12 (500)
11	Girt	18 Gauge	430 (62)	-	489 (7830)	0.12 (500)
12	Cladding with 1/2" vented airspace incorporated into exterior heat transfer coefficient					
13	Exterior Film ¹	-	-	R-0.7 (0.12 RSI)	-	-

¹ Value selected from table 1, p. 26.1 of 2009 ASHRAE Handbook – Fundamentals depending on surface orientation

Detail 8.1.32

Exterior and Interior Insulated 2x6 Wood Stud (24" o.c.) Wall Assembly with Mineral Wool and ACS-S Thermal Clip Supporting Metal Cladding with R-19 Cellulose Insulation in Stud Cavity - Clear Wall

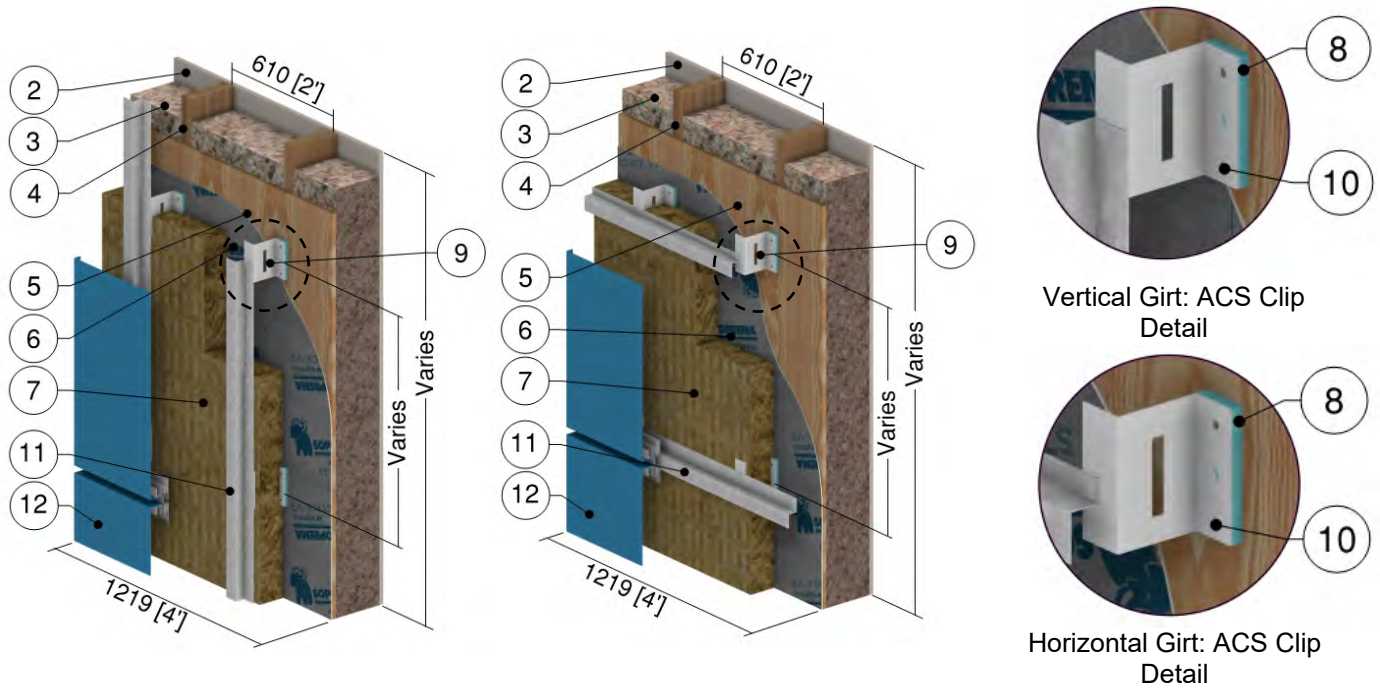

ID	Component	Thickness Inches (mm)	Conductivity Btu-in / ft ² ·hr·°F (W/m K)	Nominal Resistance hr·ft ² ·°F/Btu (m ² K/W)	Density lb/ft ³ (kg/m ³)	Specific Heat Btu/lb·°F (J/kg K)
1	Interior Film ¹	-	-	R-0.7 (0.12 RSI)	-	-
2	Gypsum Board	1/2" (13)	1.1 (0.16)	R-0.5 (0.09 RSI)	50 (800)	0.26 (1090)
3	Cellulose Insulation in Stud Cavity	5-1/2" (140)	0.29 (0.042)	R-19.0 (3.35 RSI)	1.2 (19)	0.33 (1400)
4	2x6 Wood Stud	5-1/2" (140)	0.69 (0.10)	-	31 (500)	0.45 (1880)
5	Exterior Plywood Sheathing	1/2" (13)	0.69 (0.10)	R-0.7 (0.13 RSI)	31 (500)	0.45 (1880)
6	SOPREMA SOPRASEAL STICK VP membrane	-	-	-	-	-
7	Exterior Mineral Wool Insulation	Varies	0.23 (0.034)	R-4.3 to R-34.4 (0.76 RSI to 6.06 RSI)	1.8 (28)	0.29 (1220)
8	Thermal Break	1/2" (13)	0.13 (0.019)	-	2.1 (33)	0.50 (2100)
9	ACS-S Thermal Clip	16 Gauge	118 (17)	-	500 (8000)	0.13 (530)
10	Fastener	1/4" (6.4) Ø	347 (50)	-	489 (7830)	0.12 (500)
11	Girt	18 Gauge	430 (62)	-	489 (7830)	0.12 (500)
12	Cladding with 1/2" vented airspace incorporated into exterior heat transfer coefficient					
13	Exterior Film ¹	-	-	R-0.7 (0.12 RSI)	-	-

¹ Value selected from table 1, p. 26.1 of 2009 ASHRAE Handbook – Fundamentals depending on surface orientation

Detail 8.1.33

Exterior and Interior Insulated 2x6 Wood Stud (16" o.c.) Wall Assembly with Protected SOPREMA SOPRA-ISO V PLUS and ACS-S Thermal Clip Supporting Metal Cladding with R-19 Cellulose Insulation in Stud Cavity - Clear Wall

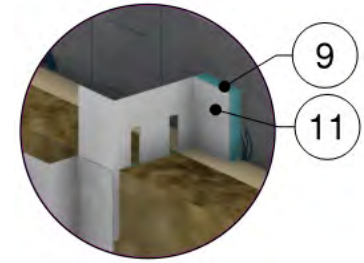
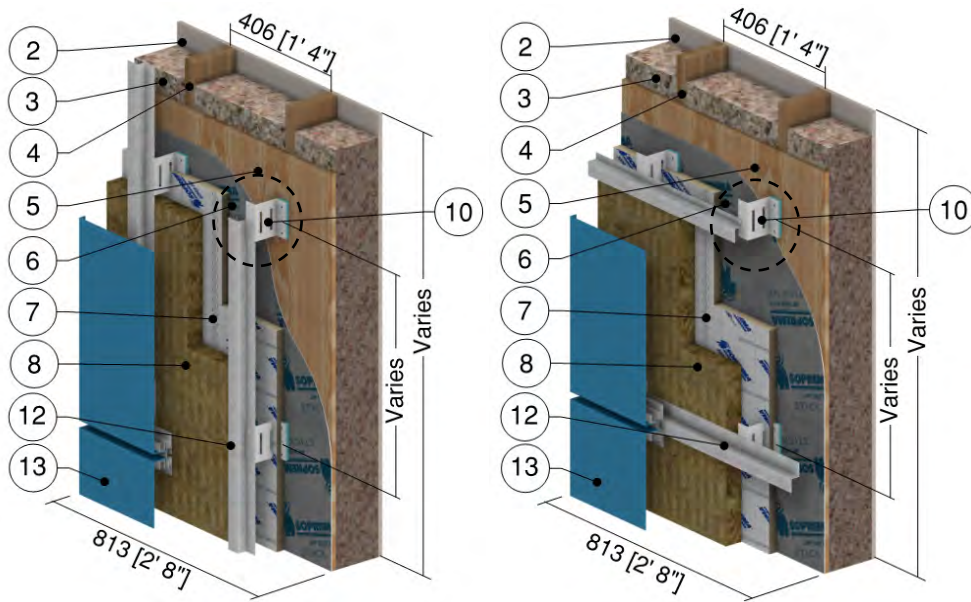

Vertical Girt: ACS Clip Detail

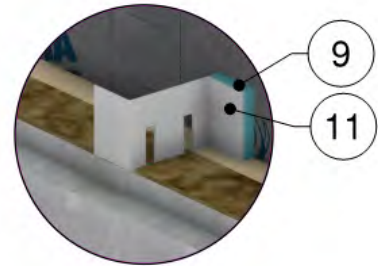

Horizontal Girt: ACS Clip Detail

ID	Component	Thickness Inches (mm)	Conductivity Btu-in / ft ² ·hr·°F (W/m K)	Nominal Resistance hr·ft ² ·°F/Btu (m ² K/W)	Density lb/ft ³ (kg/m ³)	Specific Heat Btu/lb·°F (J/kg K)
1	Interior Film ¹	-	-	R-0.7 (0.12 RSI)	-	-
2	Gypsum Board	1/2" (13)	1.1 (0.16)	R-0.5 (0.09 RSI)	50 (800)	0.26 (1090)
3	Cellulose Insulation in Stud Cavity	5-1/2" (140)	0.29 (0.042)	R-19.0 (3.35 RSI)	1.2 (19)	0.33 (1400)
4	2x6 Wood Stud	5-1/2" (140)	0.69 (0.10)	-	31 (500)	0.45 (1880)
5	Exterior Plywood Sheathing	1/2" (13)	0.69 (0.10)	R-0.7 (0.13 RSI)	31 (500)	0.45 (1880)
6	SOPREMA SOPRASEAL STICK VP membrane	-	-	-	-	-
7	SOPRA-ISO V PLUS Exterior Insulation	Varies	0.17 (0.024)	R-6.0 to R-30.0 (1.06 RSI to 5.28 RSI)	1.9 (30)	0.36 (1500)
8	Exterior Mineral Wool Insulation	2" (50)	0.23 (0.034)	R-8.6 (1.51 RSI)	1.8 (28)	0.29 (1220)
9	Thermal Break	1/2" (13)	0.13 (0.019)	-	2.1 (33)	0.50 (2100)
10	ACS-S Thermal Clip	16 Gauge	118 (17)	-	500 (8000)	0.13 (530)
11	Fastener	1/4" (6.4) Ø	347 (50)	-	489 (7830)	0.12 (500)
12	Girt	18 Gauge	430 (62)	-	489 (7830)	0.12 (500)
13	Cladding with 1/2" vented airspace incorporated into exterior heat transfer coefficient					
14	Exterior Film ¹	-	-	R-0.7 (0.12 RSI)	-	-

¹ Value selected from table 1, p. 26.1 of 2009 ASHRAE Handbook – Fundamentals depending on surface orientation

Detail 8.1.34

Exterior and Interior Insulated 2x6 Wood Stud (24" o.c.) Wall Assembly with Protected SOPREMA SOPRA-ISO V PLUS and ACS-S Thermal Clip Supporting Metal Cladding with R-19 Cellulose Insulation in Stud Cavity - Clear Wall

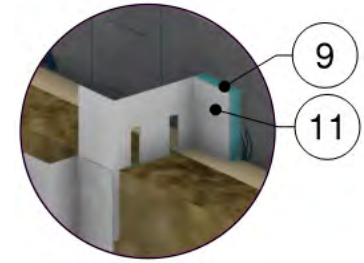
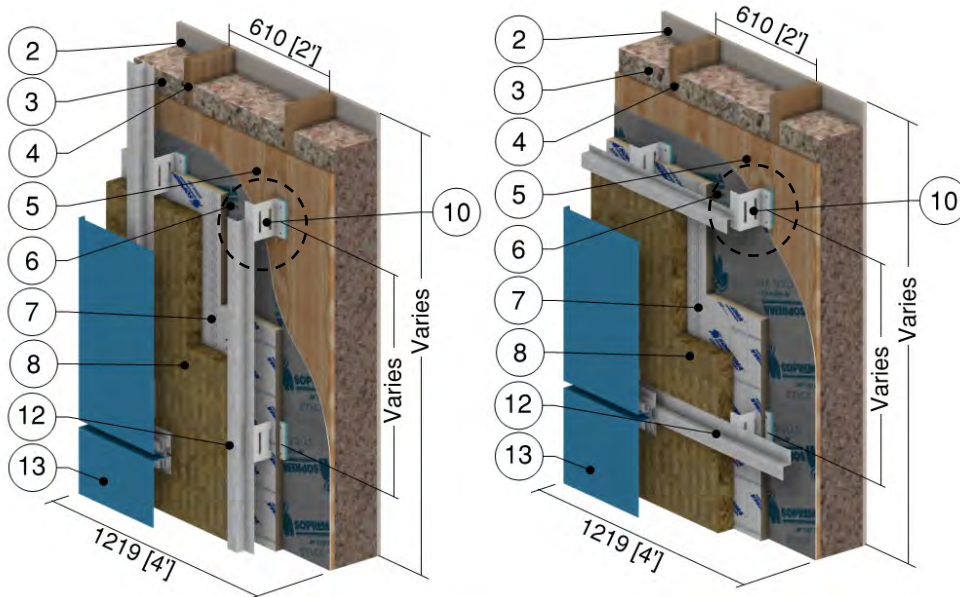

Vertical Girt: ACS Clip Detail

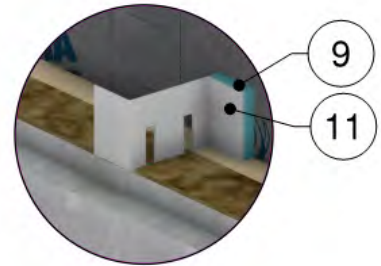

Horizontal Girt: ACS Clip Detail

ID	Component	Thickness Inches (mm)	Conductivity Btu-in / ft ² ·hr·°F (W/m K)	Nominal Resistance hr·ft ² ·°F/Btu (m ² K/W)	Density lb/ft ³ (kg/m ³)	Specific Heat Btu/lb·°F (J/kg K)
1	Interior Film ¹	-	-	R-0.7 (0.12 RSI)	-	-
2	Gypsum Board	1/2" (13)	1.1 (0.16)	R-0.5 (0.09 RSI)	50 (800)	0.26 (1090)
3	Cellulose Insulation in Stud Cavity	5-1/2" (140)	0.29 (0.042)	R-19.0 (3.35 RSI)	1.2 (19)	0.33 (1400)
4	2x6 Wood Stud	5-1/2" (140)	0.69 (0.10)	-	31 (500)	0.45 (1880)
5	Exterior Plywood Sheathing	1/2" (13)	0.69 (0.10)	R-0.7 (0.13 RSI)	31 (500)	0.45 (1880)
6	SOPREMA SOPRASEAL STICK VP membrane	-	-	-	-	-
7	SOPRA-ISO V PLUS Exterior Insulation	Varies	0.17 (0.024)	R-6.0 to R-30.0 (1.06 RSI to 5.28 RSI)	1.9 (30)	0.36 (1500)
8	Exterior Mineral Wool Insulation	2" (50)	0.23 (0.034)	R-8.6 (1.51 RSI)	1.8 (28)	0.29 (1220)
9	Thermal Break	1/2" (13)	0.13 (0.019)	-	2.1 (33)	0.50 (2100)
10	ACS-S Thermal Clip	16 Gauge	118 (17)	-	500 (8000)	0.13 (530)
11	Fastener	1/4" (6.4) Ø	347 (50)	-	489 (7830)	0.12 (500)
12	Girt	18 Gauge	430 (62)	-	489 (7830)	0.12 (500)
13	Cladding with 1/2" vented airspace incorporated into exterior heat transfer coefficient					
14	Exterior Film ¹	-	-	R-0.7 (0.12 RSI)	-	-

¹ Value selected from table 1, p. 26.1 of 2009 ASHRAE Handbook – Fundamentals depending on surface orientation

Detail 8.1.35

Exterior and Interior Insulated 2x4 Wood Stud (16" o.c.) Wall Assembly with Protected SOPREMA SOPRA-ISO V PLUS and ACS-S Thermal Clip Supporting Metal Cladding with R-13 Cellulose Insulation in Stud Cavity - Clear Wall

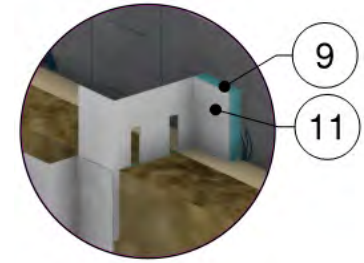
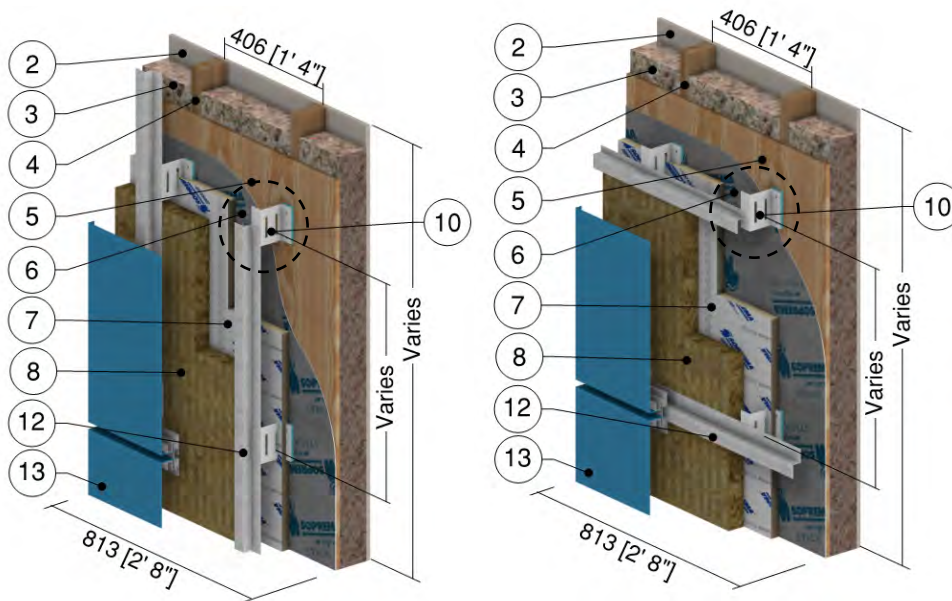

Vertical Girt: ACS Clip Detail

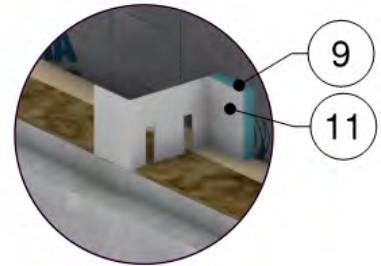

Horizontal Girt: ACS Clip Detail

ID	Component	Thickness Inches (mm)	Conductivity Btu-in / ft ² ·hr·°F (W/m K)	Nominal Resistance hr·ft ² ·°F/Btu (m ² K/W)	Density lb/ft ³ (kg/m ³)	Specific Heat Btu/lb·°F (J/kg K)
1	Interior Film ¹	-	-	R-0.7 (0.12 RSI)	-	-
2	Gypsum Board	1/2" (13)	1.1 (0.16)	R-0.5 (0.09 RSI)	50 (800)	0.26 (1090)
3	Cellulose Insulation in Stud Cavity	3-1/2" (89)	0.27 (0.039)	R-13.0 (2.29 RSI)	1.2 (19)	0.33 (1400)
4	2x4 Wood Stud	3-1/2" (89)	0.69 (0.10)	-	31 (500)	0.45 (1880)
5	Exterior Plywood Sheathing	1/2" (13)	0.69 (0.10)	R-0.7 (0.13 RSI)	31 (500)	0.45 (1880)
6	SOPREMA SOPRASEAL STICK VP membrane	-	-	-	-	-
7	SOPRA-ISO V PLUS Exterior Insulation	Varies	0.17 (0.024)	R-6.0 to R-30.0 (1.06 RSI to 5.28 RSI)	1.9 (30)	0.36 (1500)
8	Exterior Mineral Wool Insulation	2" (50)	0.23 (0.034)	R-8.6 (1.51 RSI)	1.8 (28)	0.29 (1220)
9	Thermal Break	1/2" (13)	0.13 (0.019)	-	2.1 (33)	0.50 (2100)
10	ACS-S Thermal Clip	16 Gauge	118 (17)	-	500 (8000)	0.13 (530)
11	Fastener	1/4" (6.4) Ø	347 (50)	-	489 (7830)	0.12 (500)
12	Girt	18 Gauge	430 (62)	-	489 (7830)	0.12 (500)
13	Cladding with 1/2" vented airspace incorporated into exterior heat transfer coefficient					
14	Exterior Film ¹	-	-	R-0.7 (0.12 RSI)	-	-

¹ Value selected from table 1, p. 26.1 of 2009 ASHRAE Handbook – Fundamentals depending on surface orientation

Detail 8.1.36

Exterior and Interior Insulated 2x4 Wood Stud (24" o.c.) Wall Assembly with Protected SOPREMA SOPRA-ISO V PLUS and ACS-S Thermal Clip Supporting Metal Cladding with R-13 Cellulose Insulation in Stud Cavity - Clear Wall

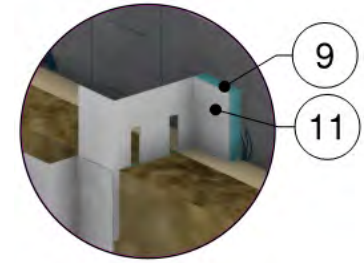
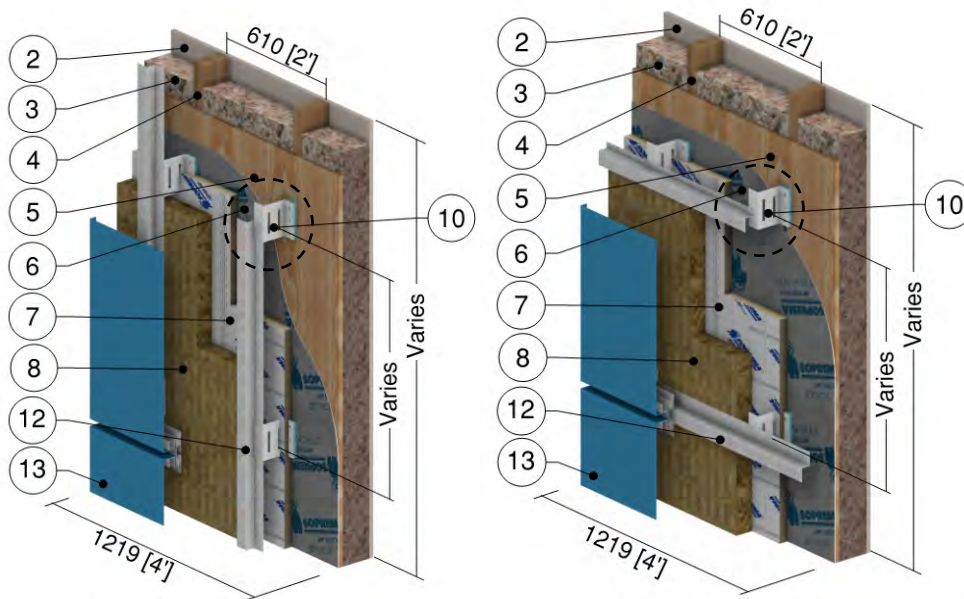

Vertical Girt: ACS Clip Detail

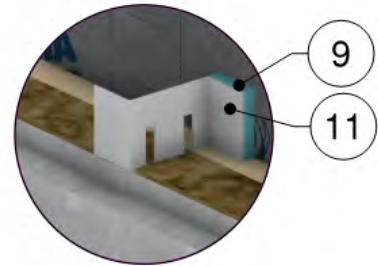

Horizontal Girt: ACS Clip Detail

ID	Component	Thickness Inches (mm)	Conductivity Btu-in / ft ² ·hr·°F (W/m K)	Nominal Resistance hr·ft ² ·°F/Btu (m ² K/W)	Density lb/ft ³ (kg/m ³)	Specific Heat Btu/lb·°F (J/kg K)
1	Interior Film ¹	-	-	R-0.7 (0.12 RSI)	-	-
2	Gypsum Board	1/2" (13)	1.1 (0.16)	R-0.5 (0.09 RSI)	50 (800)	0.26 (1090)
3	Cellulose Insulation in Stud Cavity	3-1/2" (89)	0.27 (0.039)	R-13.0 (2.29 RSI)	1.2 (19)	0.33 (1400)
4	2x4 Wood Stud	3-1/2" (89)	0.69 (0.10)	-	31 (500)	0.45 (1880)
5	Exterior Plywood Sheathing	1/2" (13)	0.69 (0.10)	R-0.7 (0.13 RSI)	31 (500)	0.45 (1880)
6	SOPREMA SOPRASEAL STICK VP membrane	-	-	-	-	-
7	SOPRA-ISO V PLUS Exterior Insulation	Varies	0.17 (0.024)	R-6.0 to R-30.0 (1.06 RSI to 5.28 RSI)	1.9 (30)	0.36 (1500)
8	Exterior Mineral Wool Insulation	2" (50)	0.23 (0.034)	R-8.6 (1.51 RSI)	1.8 (28)	0.29 (1220)
9	Thermal Break	1/2" (13)	0.13 (0.019)	-	2.1 (33)	0.50 (2100)
10	ACS-S Thermal Clip	16 Gauge	118 (17)	-	500 (8000)	0.13 (530)
11	Fastener	1/4" (6.4) Ø	347 (50)	-	489 (7830)	0.12 (500)
12	Girt	18 Gauge	430 (62)	-	489 (7830)	0.12 (500)
13	Cladding with 1/2" vented airspace incorporated into exterior heat transfer coefficient					
14	Exterior Film ¹	-	-	R-0.7 (0.12 RSI)	-	-

¹ Value selected from table 1, p. 26.1 of 2009 ASHRAE Handbook – Fundamentals depending on surface orientation

Detail 8.1.37

Exterior and Interior Insulated 2x6 Wood Stud (8" o.c.) Wall Assembly with Wood Strapping and Continuous Insulation Supporting Rainscreen Fiber Cement Board and R-19 Batt Insulation in Stud Cavity – Clear Wall

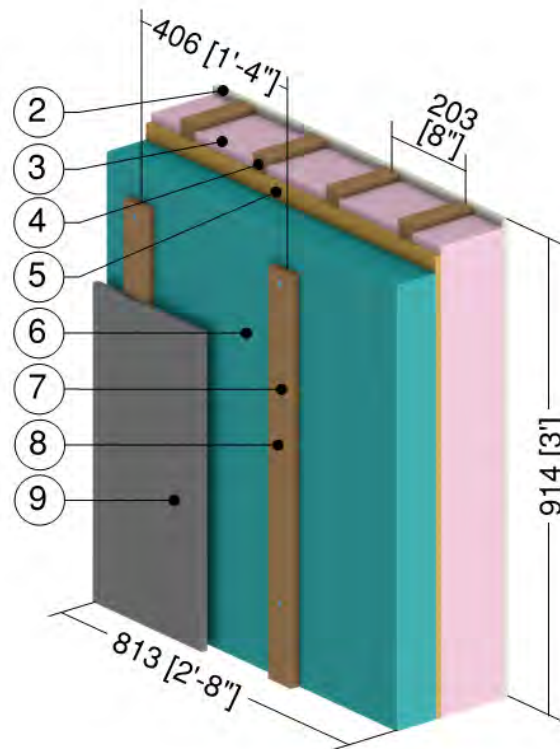

ID	Component	Thickness Inches (mm)	Conductivity Btu-in / ft ² ·hr·°F (W/m K)	Nominal Resistance hr·ft ² ·°F/Btu (m ² K/W)	Density lb/ft ³ (kg/m ³)	Specific Heat Btu/lb·°F (J/kg K)
1	Interior Film ¹	-	-	R-0.7 (0.12 RSI)	-	-
2	Gypsum Board	1/2" (13)	1.1 (0.16)	R-0.5 (0.08 RSI)	50 (800)	0.26 (1090)
3	Fiberglass Batt Insulation	5 1/2" (140)	0.29 (0.042)	R-19 (3.3 RSI)	0.9 (14)	0.17 (710)
4	2x6 Wood Stud (8" o.c.)	5 1/2" (140)	0.69 (0.10)	-	31 (500)	0.45 (1880)
5	Exterior Wood Sheathing	1/2" (16)	0.69 (0.10)	R-0.7 (0.12 RSI)	31 (500)	0.45 (1880)
6	Exterior Insulation	Varies	-	R-0 to R-15 (0 RSI to 2.64 RSI)	1.8 (28)	0.29 (1220)
7	1x3 Wood Strapping	3/4" (19)	0.69 (0.10)	-	31 (500)	0.45 (1880)
8	Steel Fasteners (12" o.c.)	0.44" (11) ∅	347 (50)	-	489 (7830)	0.12 (500)
9	Fiber Cement Board Cladding with 3/4" (19mm) vented airspace incorporated into exterior heat transfer coefficient					
10	Exterior Film ¹	-	-	R-0.7 (0.12 RSI)	-	-

¹ Value selected from table 1, p. 26.1 of 2009 ASHRAE Handbook – Fundamentals depending on surface orientation

Detail 8.2.1

Exterior and Interior Insulated 2x6 Wood Stud (16" o.c.) Wall Assembly with Wood Strapping Supporting Fiber Cement Board and R-19 Batt Insulation in Stud Cavity - Rim Joist and Floor Intersection with Metal Flashing Bypassing Exterior Insulation

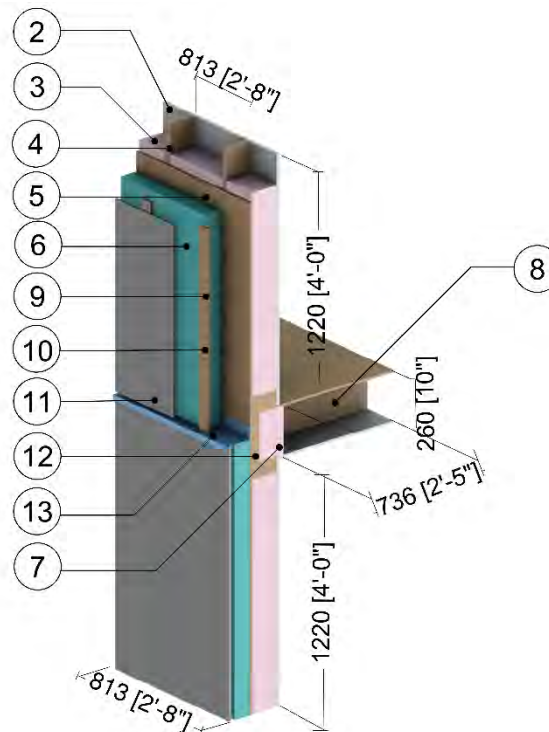

ID	Component	Thickness Inches (mm)	Conductivity Btu-in / ft ² ·hr·°F (W/m K)	Nominal Resistance hr·ft ² ·°F/Btu (m ² K/W)	Density lb/ft ³ (kg/m ³)	Specific Heat Btu/lb·°F (J/kg K)
1	Interior Film ¹	-	-	R-0.6 to R-0.9 (0.11 RSI to 0.16 RSI)	-	-
2	Gypsum Board	1/2" (13)	1.1 (0.16)	R-0.5 (0.08 RSI)	50 (800)	0.26 (1090)
3	Fiberglass Batt Insulation	5 1/2" (140)	0.29 (0.042)	R-19 (3.3 RSI)	0.9 (14)	0.17 (710)
4	2x6 Wood Stud (16" o.c.)	5 1/2" (140)	0.69 (0.10)	-	31 (500)	0.45 (1880)
5	Exterior Plywood Sheathing	1/2" (13)	0.69 (0.10)	R-0.7 (0.13 RSI)	31 (500)	0.45 (1880)
6	Exterior Insulation	varies	-	R-5 to R-15 (0.88 RSI to 2.64 RSI)	1.8 (28)	0.29 (1220)
7	Fiberglass Batt Insulation at Joist	5 1/2" (140)	0.29 (0.042)	R-19 (3.3 RSI)	0.9 (14)	0.17 (710)
8	2x10 Wood Joists (16" o.c.)	9 1/4" (235)	0.69 (0.10)	-	31 (500)	0.45 (1880)
9	Wood Strapping (1" x 3")	1 1/2" (38)	0.69 (0.10)	-	31 (500)	0.45 (1880)
10	Steel Fasteners (16" o.c.)	0.35" (9) Ø	347 (50)	-	489 (7830)	0.12 (500)
11	Fiber Cement Board Cladding with 3/4" (19mm) vented airspace incorporated into exterior heat transfer coefficient					
12	2x10 Rim Board	1 1/2" (38)	0.69 (0.10)	-	31 (510)	0.45 (1880)
13	Steel Flashing	18 Gauge	430 (62)	-	489 (7830)	0.12 (500)
14	Exterior Film ¹	-	-	R-0.7 (0.12 RSI)	-	-

¹ Value selected from table 1, p. 26.1 of 2009 ASHRAE Handbook – Fundamentals depending on surface orientation

Detail 8.2.2

Exterior and Interior Insulated 2x6 Wood Stud (16" o.c.) Wall Assembly with Wood Strapping Supporting Fiber Cement Board and R-19 Batt Insulation in Stud Cavity - Rim Joist and Floor Intersection without Metal Flashing Bypassing Exterior Insulation

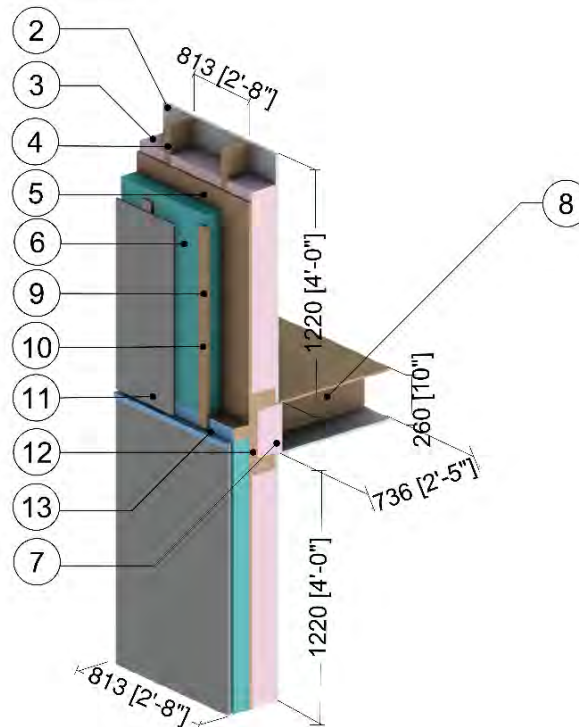

ID	Component	Thickness Inches (mm)	Conductivity Btu-in / ft ² -hr-°F (W/m K)	Nominal Resistance hr-ft ² -°F/Btu (m ² K/W)	Density lb/ft ³ (kg/m ³)	Specific Heat Btu/lb-°F (J/kg K)
1	Interior Film ¹	-	-	R-0.6 to R-0.9 (0.11 RSI to 0.16 RSI)	-	-
2	Gypsum Board	1/2" (13)	1.1 (0.16)	R-0.5 (0.08 RSI)	50 (800)	0.26 (1090)
3	Fiberglass Batt Insulation	5 1/2" (140)	0.29 (0.042)	R-19 (3.3 RSI)	0.9 (14)	0.17 (710)
4	2x6 Wood Stud (16" o.c.)	5 1/2" (140)	0.69 (0.10)	-	31 (500)	0.45 (1880)
5	Exterior Plywood Sheathing	1/2" (13)	0.69 (0.10)	R-0.7 (0.13 RSI)	31 (500)	0.45 (1880)
6	Exterior Insulation	Varies	-	R-5 to R-15 (0.88 RSI to 2.64 RSI)	1.8 (28)	0.29 (1220)
7	Fiberglass Batt Insulation at Joist	5 1/2" (140)	0.29 (0.042)	R-19 (3.3 RSI)	0.9 (14)	0.17 (710)
8	2x10 Wood Joists (16" o.c.)	9 1/4" (235)	0.69 (0.10)	-	31 (500)	0.45 (1880)
9	1x3 Wood Strapping	3/4" (19)	0.69 (0.10)	-	31 (500)	0.45 (1880)
10	Steel Fasteners (16" o.c.)	0.35" (9) Ø	347 (50)	-	489 (7830)	0.12 (500)
11	Fiber Cement Board Cladding with 3/4" (19mm) vented airspace incorporated into exterior heat transfer coefficient					
12	2x10 Rim Joist	1 1/2" (38)	0.69 (0.10)	-	31 (510)	0.45 (1880)
13	Steel Flashing	18 Gauge	430 (62)	-	489 (7830)	0.12 (500)
14	Exterior Film ¹	-	-	R-0.7 (0.12 RSI)	-	-

¹ Value selected from table 1, p. 26.1 of 2009 ASHRAE Handbook – Fundamentals depending on surface orientation

Detail 8.2.3

Exterior and Interior Insulated 2x6 Wood Stud (16" o.c.) Wall Assembly with Wood Strapping Supporting Fiber Cement Board and R-19 Batt Insulation in Stud Cavity - Cantilevered Wood Joist Balcony Intersection

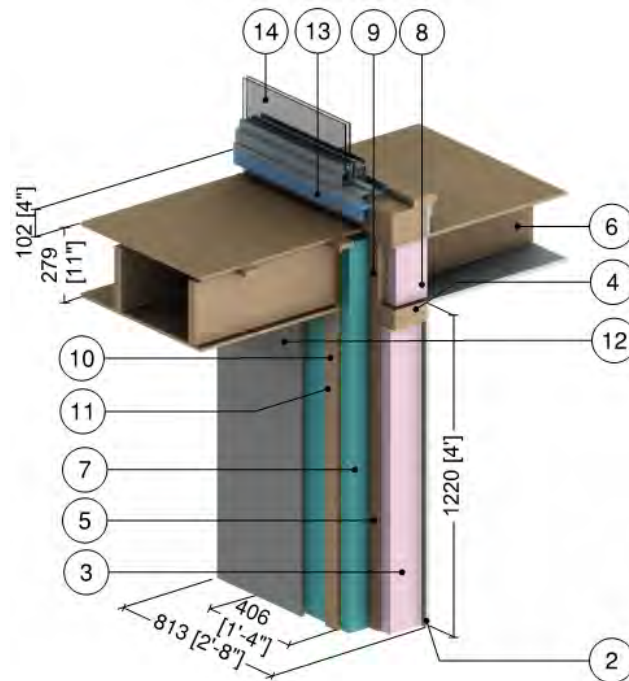

ID	Component	Thickness Inches (mm)	Conductivity Btu-in / ft ² ·hr·°F (W/m K)	Nominal Resistance hr·ft ² ·°F/Btu (m ² K/W)	Density lb/ft ³ (kg/m ³)	Specific Heat Btu/lb·°F (J/kg K)
1	Interior Film ¹	-	-	R-0.6 to R-0.9 (0.11 RSI to 0.16 RSI)	-	-
2	Gypsum Board	1/2" (13)	1.1 (0.16)	R-0.5 (0.08 RSI)	50 (800)	0.26 (1090)
3	Fiberglass Batt Insulation	5 1/2" (140)	0.29 (0.042)	R-19 (3.3 RSI)	0.9 (14)	0.17 (710)
4	2x6 Wood Stud (16" OC)	5 1/2" (140)	0.69 (0.10)	-	31 (500)	0.45 (1880)
5	Exterior Wood Sheathing	1/2" (13)	0.69 (0.10)	R-0.7 (0.12 RSI)	31 (500)	0.26 (1090)
6	2x10 Wood Joist (16" OC)	9 1/4" (235)	0.69 (0.10)	-	31 (500)	0.45 (1880)
7	Exterior Insulation	Varies	-	R-10 to R-15 (1.76 RSI to 2.64 RSI)	1.8 (28)	0.29 (1220)
8	Fiberglass Batt Insulation at Joist	5 1/2" (140)	0.29 (0.042)	R-19 (3.3 RSI)	0.9 (14)	0.17 (710)
9	2x10 Rim Joist	1 1/2" (38)	0.69 (0.10)	-	31 (500)	0.45 (1880)
10	1x3 Wood Strapping	3/4" (19)	0.69 (0.10)	-	31 (500)	0.45 (1880)
11	Steel Fasteners (16" o.c.)	0.35" (9) Ø	347 (50)	-	489 (7830)	0.12 (500)
12	Fiber Cement Board Cladding with 3/4" (19mm) vented airspace incorporated into exterior heat transfer coefficient					
13	Steel Flashing	18 Gauge	430 (62)	-	489 (7830)	0.12 (500)
14	Aluminum Sliding Door: double glazed & thermally broken ² , double glazed IGU U _{IGU} = 0.32 BTU/hr·ft ² ·°F (1.82 W/m ² K)					
15	Exterior Film ¹	-	-	R-0.2 to R-0.7 (0.03 RSI to 0.12 RSI)	-	-

¹ Value selected from table 1, p. 26.1 of 2009 ASHRAE Handbook – Fundamentals depending on surface orientation

² The thermal conductivity of air spaces within framing was found using ISO 100077-2

Detail 8.2.4

Exterior and Interior Insulated 2x6 Wood Stud (16" o.c.) Wall Assembly with Wood Strapping Supporting Fiber Cement Board and R-19 Batt Insulation in Stud Cavity – Independently Supported Balcony Intersection

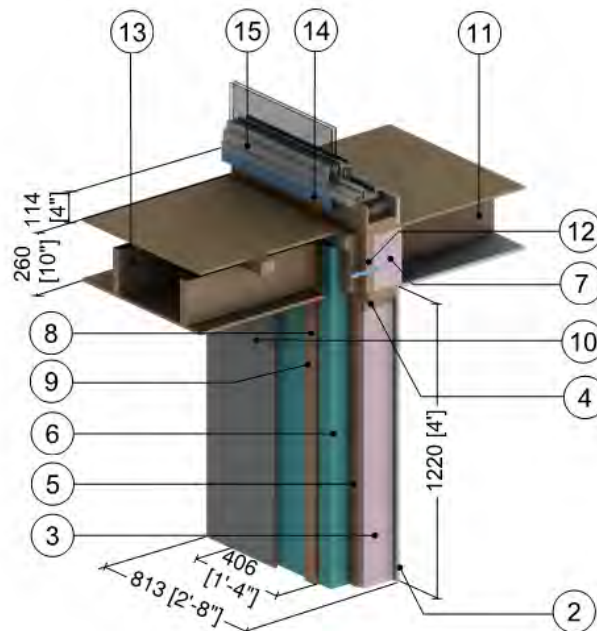

ID	Component	Thickness Inches (mm)	Conductivity Btu·in / ft ² ·hr·°F (W/m K)	Nominal Resistance hr·ft ² ·°F/Btu (m ² K/W)	Density lb/ft ³ (kg/m ³)	Specific Heat Btu/lb·°F (J/kg K)
1	Interior Film ¹	-	-	R-0.6 to R-0.9 (0.11 RSI to 0.16 RSI)	-	-
2	Gypsum Board	1/2" (13)	1.1 (0.16)	R-0.5 (0.08 RSI)	50 (800)	0.26 (1090)
3	Fiberglass Batt Insulation	5 1/2" (140)	0.29 (0.042)	R-19 (3.3 RSI)	0.9 (14)	0.17 (710)
4	2x6 Wood Stud (16" o.c.)	5 1/2" (140)	0.69 (0.10)		31 (500)	0.45 (1880)
5	Exterior Plywood Sheathing	1/2" (13)	0.69 (0.10)	R-0.7 (0.12 RSI)	31 (500)	0.45 (1880)
6	Exterior Insulation	Varies	-	R-10 to R-15 (1.76 RSI to 2.64 RSI)	1.8 (28)	0.29 (1220)
7	Fiberglass Batt Insulation at Joist	5 1/2" (140)	0.29 (0.042)	R-19 (3.3 RSI)	0.9 (14)	0.17 (710)
8	1x3 Wood Strapping	3/4" (19)	0.69 (0.10)	-	31 (500)	0.45 (1880)
9	Steel Fasteners (16" o.c.)	0.35" (9) Ø	347 (50)	-	489 (7830)	0.12 (500)
10	Fiber Cement Board Cladding with 3/4" (19mm) vented airspace incorporated into exterior heat transfer coefficient					
11	2x10 Wood Joist (16" o.c.)	9 1/4" (235)	0.69 (0.10)	-	32 (510)	0.45 (1880)
12	2x10 Rim Joist	1 1/2" (38)	0.69 (0.10)	-	31 (500)	0.45 (1880)
13	2x8 Wood Balcony Joists (16" o.c.)	5 1/2" (140)	0.69 (0.10)	-	31 (500)	0.45 (1880)
14	Steel Flashing	18 Gauge	430 (62)	-	489 (7830)	0.12 (500)
15	Aluminum Sliding Door: double glazed & thermally broken ² , double glazed IGU U _{IGU} = 0.32 BTU/hr·ft ² ·°F (1.82 W/m ² K)					
16	Exterior Film ¹	-	-	R-0.2 to R-0.7 (0.03 RSI to 0.12 RSI)	-	-

¹ Value selected from table 1, p. 26.1 of 2009 ASHRAE Handbook – Fundamentals depending on surface orientation

² The thermal conductivity of air spaces within framing was found using ISO 100077

Detail 8.2.5

Exterior and Interior Insulated 2x6 Wood Stud (16" o.c.) Wall Assembly with Wood Strapping and Continuous Insulation Supporting Fiber Cement Board and R-19 Batt Insulation in Stud Cavity – Cantilevered Floor Intersection

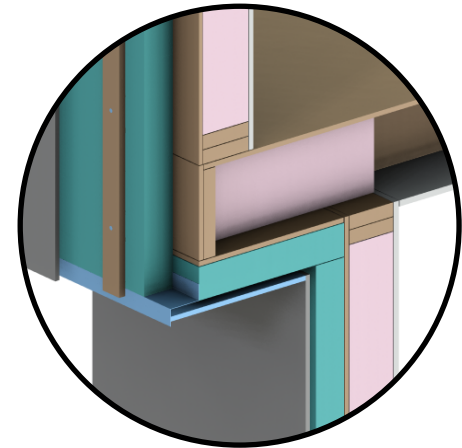
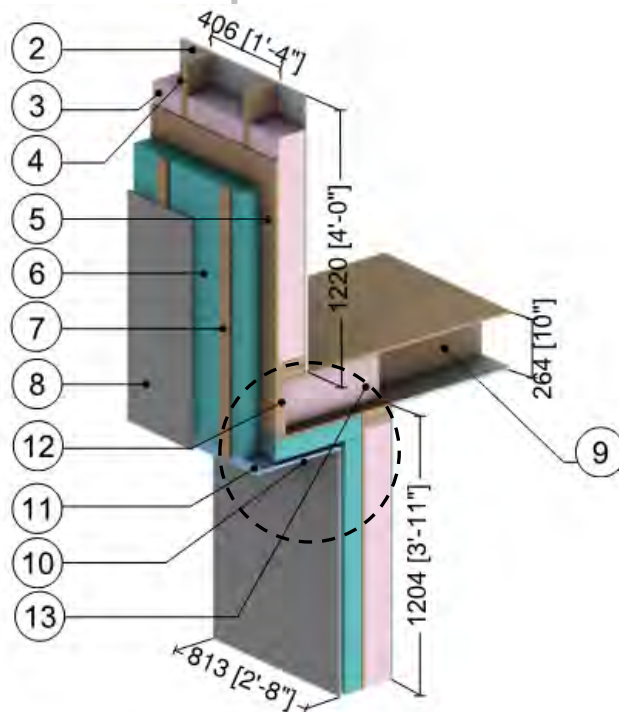

Soffit/Intersection Detail

ID	Component	Thickness Inches (mm)	Conductivity Btu·in / ft ² ·hr·°F (W/m K)	Nominal Resistance hr·ft ² ·°F/Btu (m ² K/W)	Density lb/ft ³ (kg/m ³)	Specific Heat Btu/lb·°F (J/kg K)
1	Interior Film ¹	-	-	R-0.6 to R-0.9 (0.11 RSI to 0.16 RSI)	-	-
2	Gypsum Board	5/8" (16)	1.1 (0.16)	R-0.6 (0.20 RSI)	50 (800)	0.26 (1090)
3	Fiberglass Batt Insulation	5 1/2" (140)	0.29 (0.042)	R-19 (3.3 RSI)	0.9 (14)	0.17 (710)
4	2x6 Wood Stud (16" o.c.)	5 1/2" (140)	0.69 (0.10)	-	31 (500)	0.45 (1880)
5	Exterior Wood Sheathing	5/8" (16)	0.69 (0.10)	R-0.6 (0.10 RSI)	31 (500)	0.45 (1880)
6	Exterior Insulation	Varies	0.24 (0.0343)	R-10 to R-15 (1.76 RSI to 2.64 RSI)	1.8 (28)	0.29 (1220)
7	1x3 Wood Strapping	3/4" (19)	0.69 (0.10)	-	31 (500)	0.45 (1880)
8	Fiber Cement Board Cladding with 3/4" (19mm) vented airspace incorporated into exterior heat transfer coefficient					
9	2x10 Wood Joist (16" o.c.)	9 1/4" (235)	0.69 (0.10)	-	31 (500)	0.45 (1880)
10	Vented Aluminum Soffit Panel is incorporated into the exterior heat transfer coefficient					
11	Flashing	18 Gauge	430 (62)	-	489 (7830)	0.12 (500)
12	2x10 Rim Joist	1 1/2"	0.69 (0.10)	-	31 (500)	0.45 (1880)
13	Fiberglass Batt Insulation in Floor	9 1/4" (235)	0.33 (0.048)	R-28 (4.9 RSI)	0.9 (14)	0.17 (710)
14	Exterior Film ¹	-	-	R-0.7 (0.12 RSI)	-	-

¹ Value selected from table 1, p. 26.1 of 2009 ASHRAE Handbook – Fundamentals depending on surface orientation

Detail 8.2.6

Interior Insulated Double Framed Wall 2x6 and 2x4 Wood Stud (16" o.c.) Wall Assembly with 2" Gap – Rim Joist and Floor Intersection

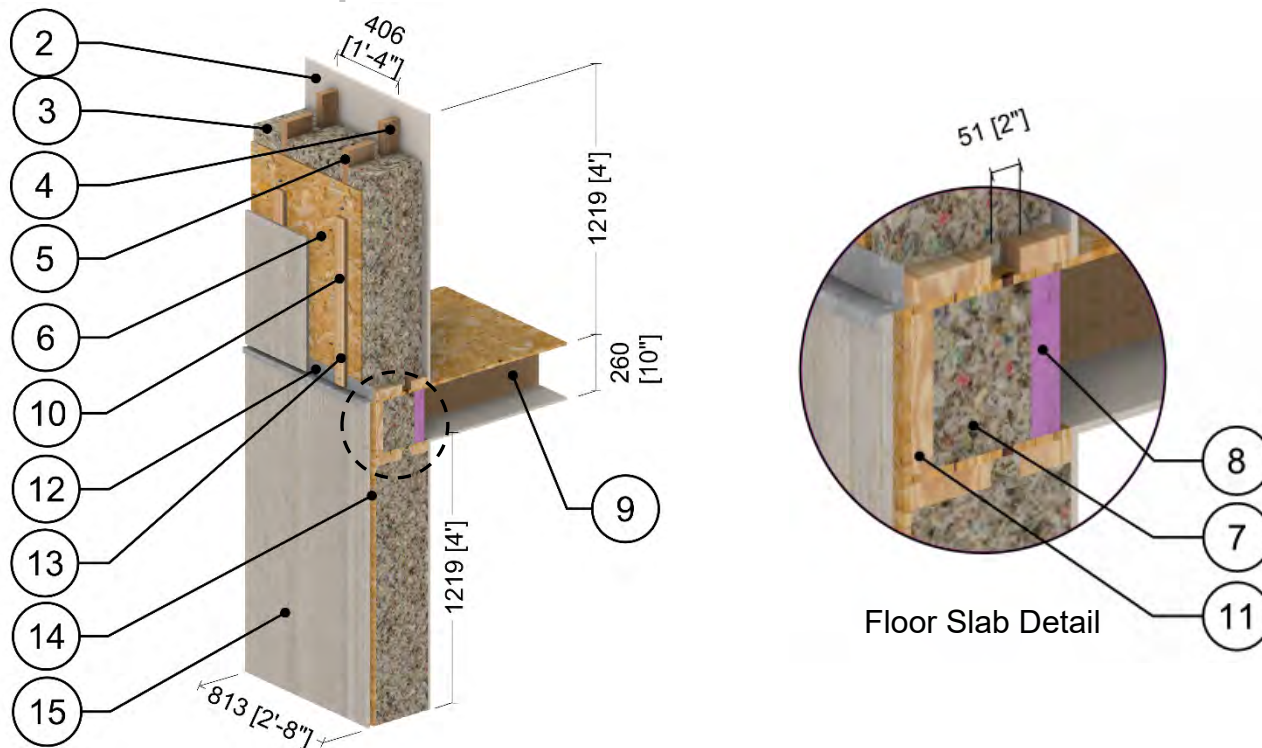

ID	Component	Thickness Inches (mm)	Conductivity Btu-in / ft ² ·hr·°F (W/m K)	Nominal Resistance hr·ft ² ·°F/Btu (m ² K/W)	Density lb/ft ³ (kg/m ³)	Specific Heat Btu/lb·°F (J/kg K)
1	Interior Film ¹	-	-	R-0.6 to R-0.9 (0.11 RSI to 0.16 RSI)	-	-
2	Gypsum Board	1/2" (13)	1.1 (0.16)	R-0.5 (0.08 RSI)	50 (800)	0.26 (1090)
3	Fill Insulation	11" (279)	Varies	-	-	-
4	2x4 Wood Stud (16" o.c.)	3 1/2" (89)	0.69 (0.10)	-	31 (500)	0.45 (1880)
5	2x6 Wood Stud (16" o.c.)	5 1/2" (140)	0.69 (0.10)	-	31 (500)	0.45 (1880)
6	Exterior Plywood Sheathing	1/2" (13)	0.69 (0.10)	R-0.7 (0.13 RSI)	31 (500)	0.45 (1880)
7	Fill Insulation at Joist	6 3/4" (171)	Varies	-	-	-
8	XPS Insulation	2" (51)	0.20 (0.029)	R-10 (1.76 RSI)	1.8 (28)	0.29 (1220)
9	2x10 Wood Joists (16" o.c.)	9 1/4" (235)	0.69 (0.10)	-	31 (500)	0.45 (1880)
10	Steel Fasteners (12" o.c.)	0.43" (11) Ø	347 (50)	-	489 (7830)	0.12 (500)
11	2x10 Rim Joist	1 1/2" (38)	0.69 (0.10)	-	31 (510)	0.45 (1880)
12	Steel Flashing	18 Gauge	430 (62)	-	489 (7830)	0.12 (500)
13	Wood Strapping (1" x 3")	3/4" (19)	0.69 (0.10)	-	31 (500)	0.45 (1880)
14	Rainscreen Cavity	3/4" (19)	-	R-0.4 (0.07 RSI)	0.075 (1.2)	0.24 (1000)
15	Fiber Cement Board	1/2" (13)	4.86 (0.7)	-	-	-
16	Exterior Film ¹	-	-	R-0.2 (0.03 RSI)	-	-

¹ Value selected from table 1, p. 26.1 of 2009 ASHRAE Handbook – Fundamentals depending on surface orientation

Detail 8.2.7

Interior Insulated Double Framed Wall 2x6 and 2x4 Wood Stud (16" o.c.) Wall Assembly with 3" Gap – Rim Joist and Floor Intersection

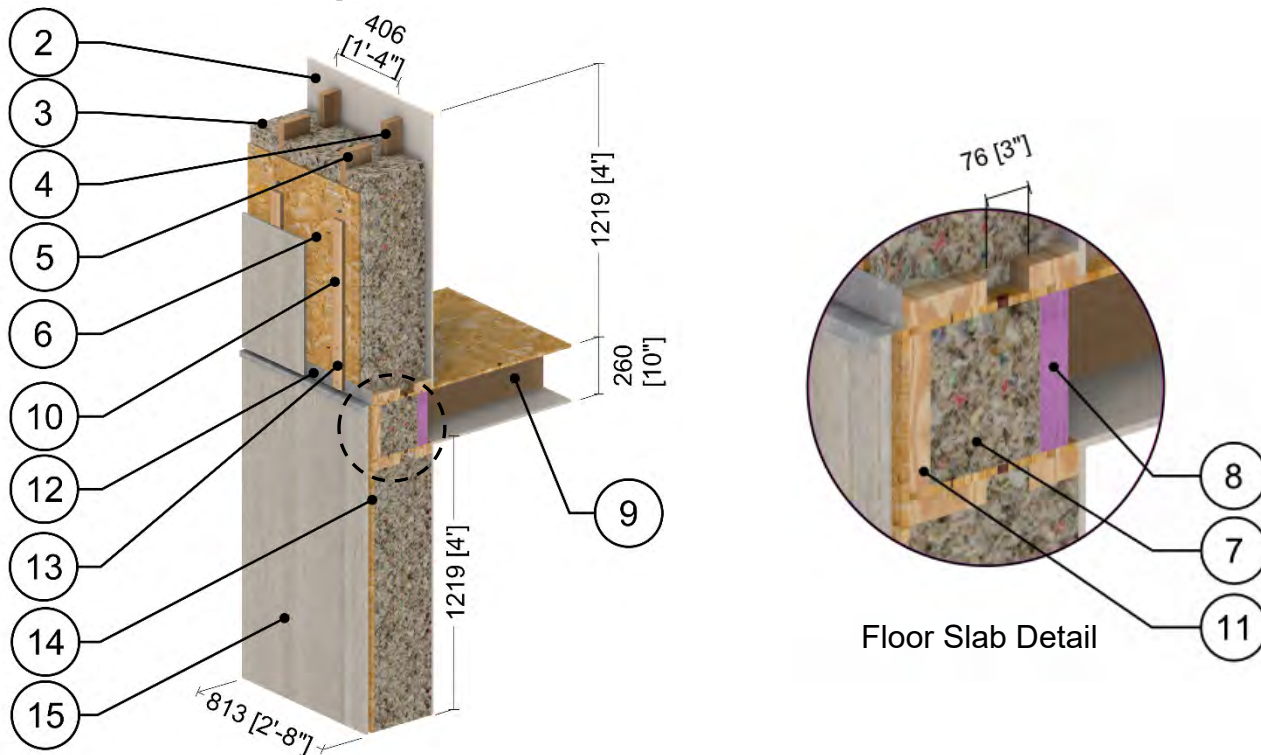

ID	Component	Thickness Inches (mm)	Conductivity Btu-in / ft ² -hr-°F (W/m K)	Nominal Resistance hr-ft ² -°F/Btu (m ² K/W)	Density lb/ft ³ (kg/m ³)	Specific Heat Btu/lb-°F (J/kg K)
1	Interior Film ¹	-	-	R-0.6 to R-0.9 (0.11 RSI to 0.16 RSI)	-	-
2	Gypsum Board	1/2" (13)	1.1 (0.16)	R-0.5 (0.08 RSI)	50 (800)	0.26 (1090)
3	Fill Insulation	12" (305)	Varies	-	-	-
4	2x4 Wood Stud (16" o.c.)	3 1/2" (89)	0.69 (0.10)	-	31 (500)	0.45 (1880)
5	2x6 Wood Stud (16" o.c.)	5 1/2" (140)	0.69 (0.10)	-	31 (500)	0.45 (1880)
6	Exterior Plywood Sheathing	1/2" (13)	0.69 (0.10)	R-0.7 (0.13 RSI)	31 (500)	0.45 (1880)
7	Fill Insulation at Joist	6 3/4" (171)	Varies	-	-	-
8	XPS Insulation	2" (51)	0.20 (0.029)	R-10 (1.76 RSI)	1.8 (28)	0.29 (1220)
9	2x10 Wood Joists (16" o.c.)	9 1/4" (235)	0.69 (0.10)	-	31 (500)	0.45 (1880)
10	Steel Fasteners (12" o.c.)	0.43" (11) Ø	347 (50)	-	489 (7830)	0.12 (500)
11	2x10 Rim Joist	1 1/2" (38)	0.69 (0.10)	-	31 (510)	0.45 (1880)
12	Steel Flashing	18 Gauge	430 (62)	-	489 (7830)	0.12 (500)
13	Wood Strapping (1" x 3")	3/4" (19)	0.69 (0.10)	-	31 (500)	0.45 (1880)
14	Rainscreen Cavity	3/4" (19)	-	R-0.4 (0.07 RSI)	0.075 (1.2)	0.24 (1000)
15	Fiber Cement Board	1/2" (13)	4.86 (0.7)	-	-	-
16	Exterior Film ¹	-	-	R-0.2 (0.03 RSI)	-	-

¹ Value selected from table 1, p. 26.1 of 2009 ASHRAE Handbook – Fundamentals depending on surface orientation

Detail 8.2.8

Interior Insulated Double Framed Wall 2x6 and 2x4 Wood Stud (16" o.c.) Wall Assembly with 4" Gap – Rim Joist and Floor Intersection

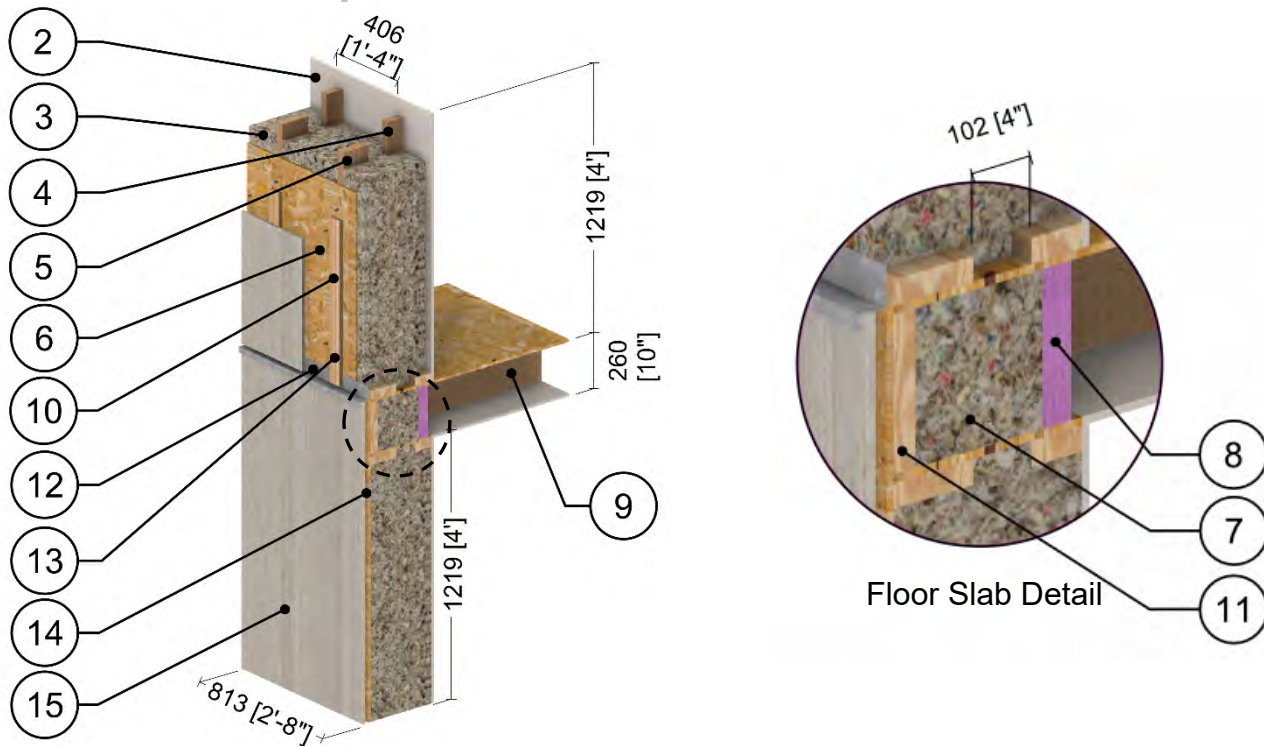

ID	Component	Thickness Inches (mm)	Conductivity Btu-in / ft ² -hr-°F (W/m K)	Nominal Resistance hr-ft ² -°F/Btu (m ² K/W)	Density lb/ft ³ (kg/m ³)	Specific Heat Btu/lb-°F (J/kg K)
1	Interior Film ¹	-	-	R-0.6 to R-0.9 (0.11 RSI to 0.16 RSI)	-	-
2	Gypsum Board	1/2" (13)	1.1 (0.16)	R-0.5 (0.08 RSI)	50 (800)	0.26 (1090)
3	Fill Insulation	13" (330)	Varies	-	-	-
4	2x4 Wood Stud (16" o.c.)	3 1/2" (89)	0.69 (0.10)	-	31 (500)	0.45 (1880)
5	2x6 Wood Stud (16" o.c.)	5 1/2" (140)	0.69 (0.10)	-	31 (500)	0.45 (1880)
6	Exterior Plywood Sheathing	1/2" (13)	0.69 (0.10)	R-0.7 (0.13 RSI)	31 (500)	0.45 (1880)
7	Fill Insulation at Joist	6 3/4" (171)	Varies	-	-	-
8	XPS Insulation	2" (51)	0.20 (0.029)	R-10 (1.76 RSI)	1.8 (28)	0.29 (1220)
9	2x10 Wood Joists (16" o.c.)	9 1/4" (235)	0.69 (0.10)	-	31 (500)	0.45 (1880)
10	Steel Fasteners (12" o.c.)	0.43" (11) Ø	347 (50)	-	489 (7830)	0.12 (500)
11	2x10 Rim Joist	1 1/2" (38)	0.69 (0.10)	-	31 (510)	0.45 (1880)
12	Steel Flashing	18 Gauge	430 (62)	-	489 (7830)	0.12 (500)
13	Wood Strapping (1" x 3")	3/4" (19)	0.69 (0.10)	-	31 (500)	0.45 (1880)
14	Rainscreen Cavity	3/4" (19)	-	R-0.4 (0.07 RSI)	0.075 (1.2)	0.24 (1000)
15	Fiber Cement Board	1/2" (13)	4.86 (0.7)	-	-	-
16	Exterior Film ¹	-	-	R-0.2 (0.03 RSI)	-	-

¹ Value selected from table 1, p. 26.1 of 2009 ASHRAE Handbook – Fundamentals depending on surface orientation

Detail 8.2.9

Interior Insulated Double Framed Wall 2x6 and 2x4 Wood Stud (16" o.c.) Wall Assembly with 2" Gap – Insulated Rim Joist and Floor Intersection

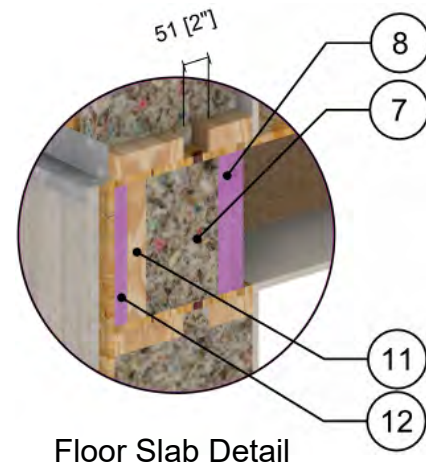
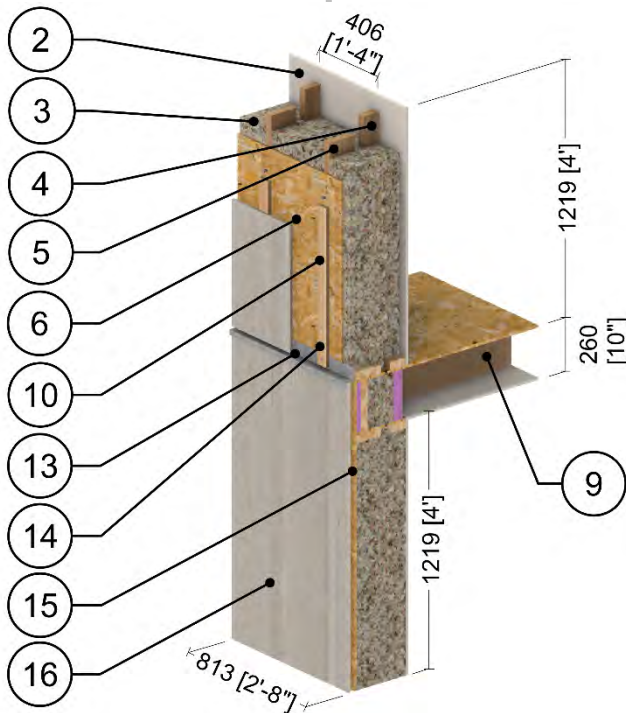

ID	Component	Thickness Inches (mm)	Conductivity Btu-in / ft ² -hr-°F (W/m K)	Nominal Resistance hr-ft ² -°F/Btu (m ² K/W)	Density lb/ft ³ (kg/m ³)	Specific Heat Btu/lb-°F (J/kg K)
1	Interior Film ¹	-	-	R-0.6 to R-0.9 (0.11 RSI to 0.16 RSI)	-	-
2	Gypsum Board	1/2" (13)	1.1 (0.16)	R-0.5 (0.08 RSI)	50 (800)	0.26 (1090)
3	Fill Insulation	11" (279)	Varies	-	-	-
4	2x4 Wood Stud (16" o.c.)	3 1/2" (89)	0.69 (0.10)	-	31 (500)	0.45 (1880)
5	2x6 Wood Stud (16" o.c.)	5 1/2" (140)	0.69 (0.10)	-	31 (500)	0.45 (1880)
6	Exterior Plywood Sheathing	1/2" (13)	0.69 (0.10)	R-0.7 (0.13 RSI)	31 (500)	0.45 (1880)
7	Fill Insulation at Joist	6 3/4" (171)	Varies	-	-	-
8	XPS Insulation	2" (51)	0.20 (0.029)	R-10 (1.76 RSI)	1.8 (28)	0.29 (1220)
9	2x10 Wood Joists (16" o.c.)	9 1/4" (235)	0.69 (0.10)	-	31 (500)	0.45 (1880)
10	Steel Fasteners (12" o.c.)	0.43" (11) Ø	347 (50)	-	489 (7830)	0.12 (500)
11	2x10 Rim Joist	1 1/2" (38)	0.69 (0.10)	-	31 (510)	0.45 (1880)
12	Rim Joist Insulation	1" (25)	0.20 (0.029)	R-5 (0.88 RSI)	1.8 (28)	0.29 (1220)
13	Steel Flashing	18 Gauge	430 (62)	-	489 (7830)	0.12 (500)
14	Wood Strapping (1" x 3")	3/4" (19)	0.69 (0.10)	-	31 (500)	0.45 (1880)
15	Rainscreen Cavity	3/4" (19)	-	R-0.4 (0.07 RSI)	0.075 (1.2)	0.24 (1000)
16	Fiber Cement Board	1/2" (13)	4.86 (0.7)	-	-	-
17	Exterior Film ¹	-	-	R-0.2 (0.03 RSI)	-	-

¹ Value selected from table 1, p. 26.1 of 2009 ASHRAE Handbook – Fundamentals depending on surface orientation



Detail 8.2.10

Interior Insulated Double Framed Wall 2x6 and 2x4 Wood Stud (16" o.c.) Wall Assembly with 3" Gap – Insulated Rim Joist and Floor Intersection

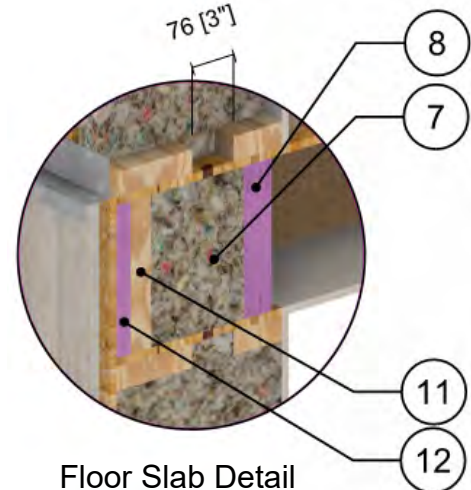
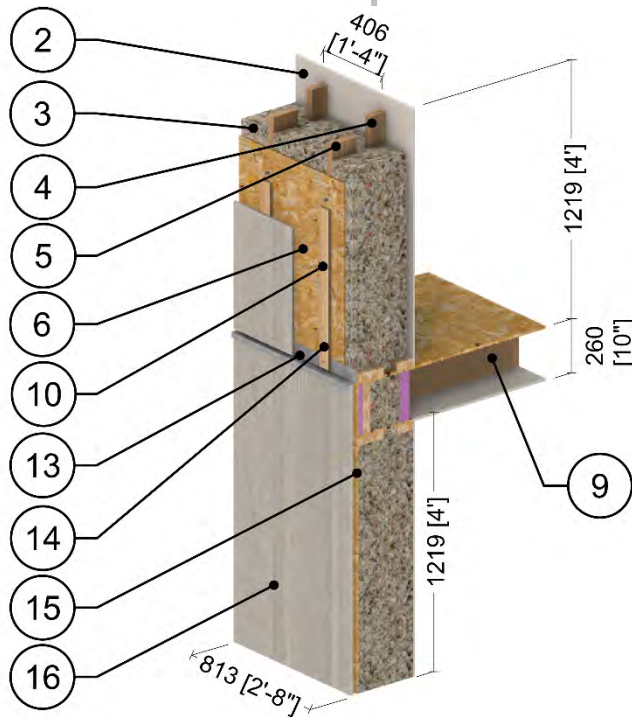

Floor Slab Detail

ID	Component	Thickness Inches (mm)	Conductivity Btu-in / ft ² -hr-°F (W/m K)	Nominal Resistance hr-ft ² -°F/Btu (m ² K/W)	Density lb/ft ³ (kg/m ³)	Specific Heat Btu/lb-°F (J/kg K)
1	Interior Film ¹	-	-	R-0.6 to R-0.9 (0.11 RSI to 0.16 RSI)	-	-
2	Gypsum Board	1/2" (13)	1.1 (0.16)	R-0.5 (0.08 RSI)	50 (800)	0.26 (1090)
3	Fill Insulation	12" (305)	Varies	-	-	-
4	2x4 Wood Stud (16" o.c.)	3 1/2" (89)	0.69 (0.10)	-	31 (500)	0.45 (1880)
5	2x6 Wood Stud (16" o.c.)	5 1/2" (140)	0.69 (0.10)	-	31 (500)	0.45 (1880)
6	Exterior Plywood Sheathing	1/2" (13)	0.69 (0.10)	R-0.7 (0.13 RSI)	31 (500)	0.45 (1880)
7	Fill Insulation at Joist	6 3/4" (171)	Varies	-	-	-
8	XPS Insulation	2" (51)	0.20 (0.029)	R-10 (1.76 RSI)	1.8 (28)	0.29 (1220)
9	2x10 Wood Joists (16" o.c.)	9 1/4" (235)	0.69 (0.10)	-	31 (500)	0.45 (1880)
10	Steel Fasteners (12" o.c.)	0.43" (11) Ø	347 (50)	-	489 (7830)	0.12 (500)
11	2x10 Rim Joist	1 1/2" (38)	0.69 (0.10)	-	31 (510)	0.45 (1880)
12	Rim Joist Insulation	1" (25)	0.20 (0.029)	R-5 (0.88 RSI)	1.8 (28)	0.29 (1220)
13	Steel Flashing	18 Gauge	430 (62)	-	489 (7830)	0.12 (500)
14	Wood Strapping (1" x 3")	3/4" (19)	0.69 (0.10)	-	31 (500)	0.45 (1880)
15	Rainscreen Cavity	3/4" (19)	-	R-0.4 (0.07 RSI)	0.075 (1.2)	0.24 (1000)
16	Fiber Cement Board	1/2" (13)	4.86 (0.7)	-	-	-
17	Exterior Film ¹	-	-	R-0.2 (0.03 RSI)	-	-

¹ Value selected from table 1, p. 26.1 of 2009 ASHRAE Handbook – Fundamentals depending on surface orientation

Detail 8.2.11

Interior Insulated Double Framed Wall 2x6 and 2x4 Wood Stud (16" o.c.) Wall Assembly with 4" Gap – Insulated Rim Joist and Floor Intersection

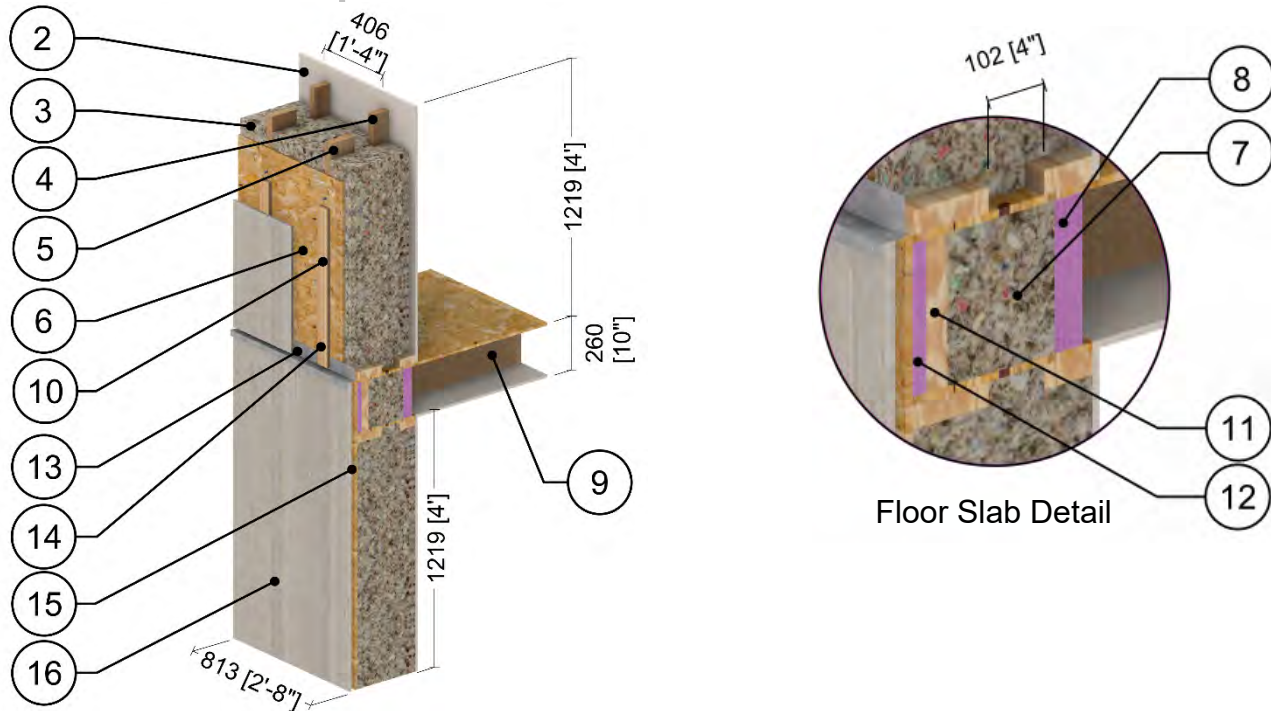

ID	Component	Thickness Inches (mm)	Conductivity Btu-in / ft ² -hr-°F (W/m K)	Nominal Resistance hr-ft ² -°F/Btu (m ² K/W)	Density lb/ft ³ (kg/m ³)	Specific Heat Btu/lb-°F (J/kg K)
1	Interior Film ¹	-	-	R-0.6 to R-0.9 (0.11 RSI to 0.16 RSI)	-	-
2	Gypsum Board	1/2" (13)	1.1 (0.16)	R-0.5 (0.08 RSI)	50 (800)	0.26 (1090)
3	Fill Insulation	13" (330)	Varies	-	-	-
4	2x4 Wood Stud (16" o.c.)	3 1/2" (89)	0.69 (0.10)	-	31 (500)	0.45 (1880)
5	2x6 Wood Stud (16" o.c.)	5 1/2" (140)	0.69 (0.10)	-	31 (500)	0.45 (1880)
6	Exterior Plywood Sheathing	1/2" (13)	0.69 (0.10)	R-0.7 (0.13 RSI)	31 (500)	0.45 (1880)
7	Fill Insulation at Joist	6 3/4" (171)	Varies	-	-	-
8	XPS Insulation	2" (51)	0.20 (0.029)	R-10 (1.76 RSI)	1.8 (28)	0.29 (1220)
9	2x10 Wood Joists (16" o.c.)	9 1/4" (235)	0.69 (0.10)	-	31 (500)	0.45 (1880)
10	Steel Fasteners (12" o.c.)	0.43" (11) Ø	347 (50)	-	489 (7830)	0.12 (500)
11	2x10 Rim Joist	1 1/2" (38)	0.69 (0.10)	-	31 (510)	0.45 (1880)
12	Rim Joist Insulation	1" (25)	0.20 (0.029)	R-5 (0.88 RSI)	1.8 (28)	0.29 (1220)
13	Steel Flashing	18 Gauge	430 (62)	-	489 (7830)	0.12 (500)
14	Wood Strapping (1" x 3")	3/4" (19)	0.69 (0.10)	-	31 (500)	0.45 (1880)
15	Rainscreen Cavity	3/4" (19)	-	R-0.4 (0.07 RSI)	0.075 (1.2)	0.24 (1000)
16	Fiber Cement Board	1/2" (13)	4.86 (0.7)	-	-	-
17	Exterior Film ¹	-	-	R-0.2 (0.03 RSI)	-	-

¹ Value selected from table 1, p. 26.1 of 2009 ASHRAE Handbook – Fundamentals depending on surface orientation

Detail 8.2.12

Exterior and Interior Insulated 2x6 Wood Stud (16" o.c.) Wall Assembly with Shelf Angle & Brick Ties Supporting Brick Veneer and R-19 Batt Insulation in Stud Cavity – Rim Joist and Floor Intersection

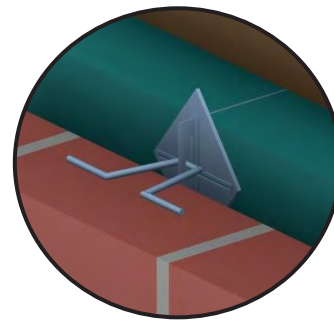
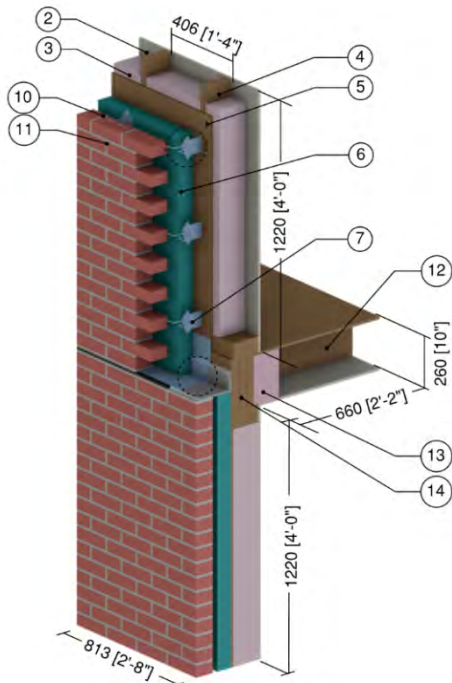

Brick Tie Detail

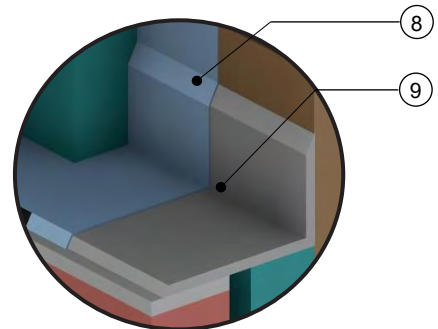

Shelf Angle Detail

ID	Component	Thickness Inches (mm)	Conductivity Btu-in / ft ² -hr-°F (W/m K)	Nominal Resistance hr-ft ² -°F/Btu (m ² K/W)	Density lb/ft ³ (kg/m ³)	Specific Heat Btu/lb-°F (J/kg K)
1	Interior Film ¹	-	-	R-0.6 to R-0.9 (0.11 RSI to 0.16 RSI)	-	-
2	Gypsum Board	1/2" (13)	1.1 (0.16)	R-0.5 (0.08 RSI)	50 (800)	0.26 (1090)
3	Fiberglass Batt Insulation in Stud Cavity	5 1/2" (140)	0.29 (0.042)	R-19 (3.3 RSI)	0.9 (14)	0.17 (710)
4	2x6 Wood Stud (16" o.c.)	5 1/2" (140)	0.69 (0.10)	-	31 (500)	0.45 (1880)
5	Exterior Plywood Sheathing	1/2" (13)	0.69 (0.10)	R-0.7 (0.13 RSI)	31 (500)	0.45 (1880)
6	Exterior Insulation	Varies	-	R-0 to R-10 (0.00 RSI to 1.76 RSI)	1.8 (28)	0.29 (1220)
7	Brick Ties	14 gauge	347 (50)	-	489 (7830)	0.12 (500)
8	Flashing	20 gauge	347 (50)	-	489 (7830)	0.12 (500)
9	Steel Shelf Angle	3/8" (10)	347 (50)	-	489 (7830)	0.12 (500)
10	Air Cavity ²	1" (25)	-	R-0.9 (0.16 RSI)	0.075 (1.2)	0.24 (1000)
11	Brick Veneer	3 5/8" (92)	5.4 (0.78)	-	140 (2250)	0.20 (850)
12	2x10 Wood Joists (16"o.c.)	9 1/4" (235)	0.69 (0.10)	-	31 (500)	0.45 (1880)
13	Fiberglass Batt Insulation at Joists	5 1/2" (140)	0.29 (0.042)	R-19 (3.3 RSI)	0.9 (14)	0.17 (710)
14	2x10 Rim Joist	1 1/2" (38)	0.69 (0.10)	-	31 (500)	0.45 (1880)
15	Exterior Film ¹	-	-	R-0.2 (0.03 RSI)	-	-

¹ Value selected from table 1, p. 26.1 of 2009 ASHRAE Handbook – Fundamentals depending on surface orientation

² The thermal conductivity of air spaces was found using ISO 100077-2



Detail 8.2.13

Exterior and Interior Insulated 2x6 Wood Stud (16" o.c.) Wall Assembly with Stand-off (Knife Plate) Shelf Angle & Brick Ties Supporting Brick Veneer and R-19 Batt Insulation in Stud Cavity – Rim Joist and Floor Intersection

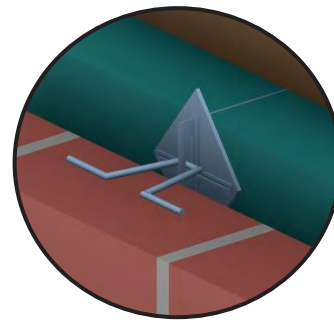
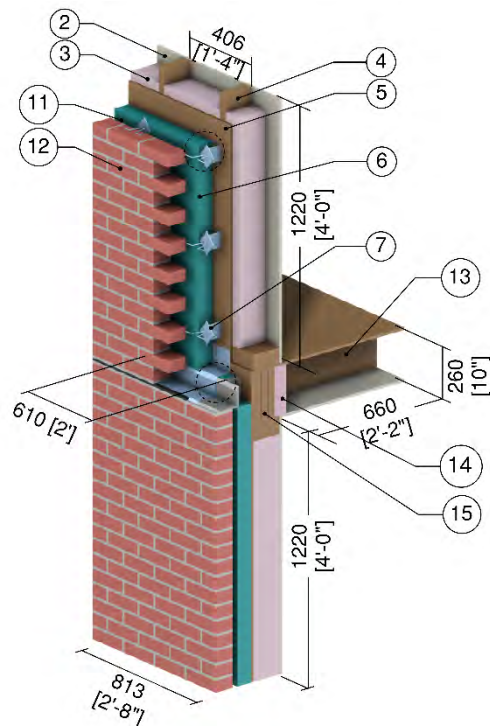

Brick Tie Detail

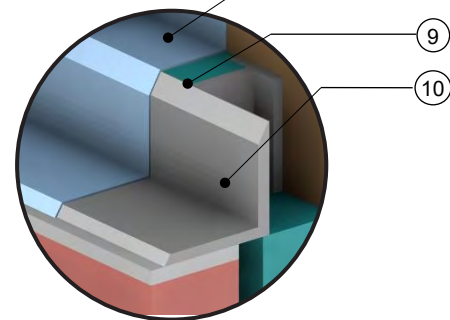

Shelf Angle Detail

ID	Component	Thickness Inches (mm)	Conductivity Btu-in / ft ² -hr-°F (W/m K)	Nominal Resistance hr-ft ² -°F/Btu (m ² K/W)	Density lb/ft ³ (kg/m ³)	Specific Heat Btu/lb-°F (J/kg K)
1	Interior Film ¹	-	-	R-0.6 to R-0.9 (0.11 RSI to 0.16 RSI)	-	-
2	Gypsum Board	1/2" (13)	1.1 (0.16)	R-0.5 (0.08RSI)	50 (800)	0.26 (1090)
3	Fiberglass Batt Insulation in Stud Cavity	5 1/2" (140)	0.29 (0.042)	R-19 (3.3 RSI)	0.9 (14)	0.17 (710)
4	2x6 Wood Stud (16" o.c.)	5 1/2" (140)	0.69 (0.10)	-	31 (500)	0.45 (1880)
5	Exterior Plywood Sheathing	1/2" (13)	0.69 (0.10)	-	31 (500)	0.45 (1880)
6	Exterior Insulation	Varies	-	R-0 to R-10 (0.00 RSI to 1.76 RSI)	1.8 (28)	0.29 (1220)
7	Brick Ties	14 gauge	347 (50)	-	489 (7830)	0.12 (500)
8	Exterior Insulation Behind Shelf Angle	Varies	-	R-0 to R-10 (0.00 RSI to 1.76 RSI)	1.8 (28)	0.29 (1220)
9	Flashing	20 gauge	347 (50)	-	489 (7830)	0.12 (500)
10	Spteel Shelf Angle	3/8" (10)	347 (50)	-	489 (7830)	0.12 (500)
11	Air Cavity ²	1" (25)	-	R-0.9 (0.16RSI)	0.075 (1.2)	0.24 (1000)
12	Brick Veneer	3 5/8" (92)	5.4 (0.78)	-	140 (2250)	0.20 (850)
13	2x10 Wood Joists (16"o.c.)	9 1/4" (235)	0.69 (0.10)	-	31 (500)	0.45 (1880)
14	Fiberglass Batt Insulation at Joists	5 1/2" (140)	0.29 (0.042)	R-19 (3.3 RSI)	0.9 (14)	0.17 (710)
15	2x10 Rim Joist	1 1/2" (38)	0.69 (0.10)	-	31 (500)	0.45 (1880)
16	Exterior Film ¹	-	-	R-0.2 (0.03 RSI)	-	-

¹ Value selected from table 1, p. 26.1 of 2009 ASHRAE Handbook – Fundamentals depending on surface orientation

² The thermal conductivity of air spaces was found using ISO 100077-2

Detail 8.2.14 Exterior Insulated 2x6 Wood Stud (16" o.c.) Wall with Interior OSB and Wood Furring Assembly with Stand-off (Knife Plate) Shelf Angle & Brick Ties Supporting Brick Veneer – CLT and Wood Truss Floor Intersection

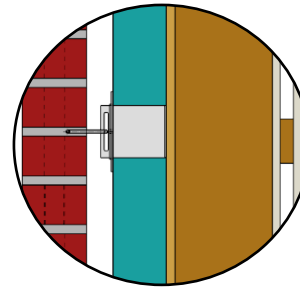
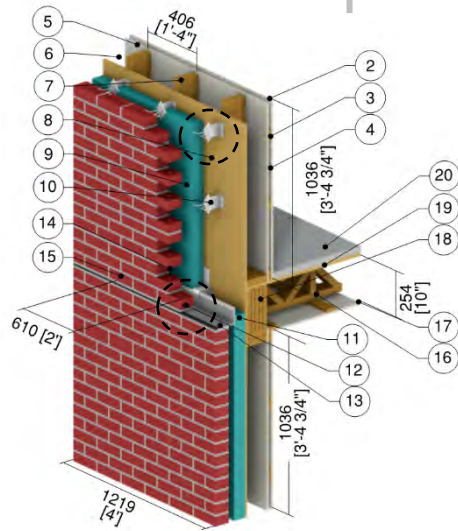

Brick Tie Detail

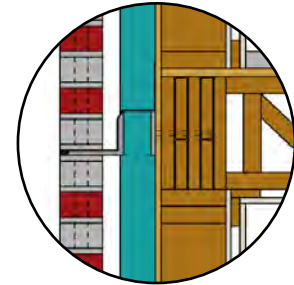

Shelf Angle Detail

ID	Component	Thickness Inches (mm)	Conductivity Btu-in / ft ² ·hr·°F (W/m K)	Nominal Resistance hr·ft ² ·°F/Btu (m ² K/W)	Density lb/ft ³ (kg/m ³)	Specific Heat Btu/lb·°F (J/kg K)
1	Interior Film ¹	-	-	R-0.6 to R-0.9 (0.11 RSI to 0.16 RSI)	-	-
2	Gypsum	1/2" (13)	1.1 (0.16)	R-0.5 (0.08 RSI)	50 (800)	0.26 (1090)
3	1x3 Wood Furring	3/4" (19)	0.69 (0.10)	-	31 (500)	0.45 (1880)
4	Air in Furring Cavity	3/4" (19)	-	R-0.9 (0.16 RSI)	0.075 (1.2)	0.24 (1000)
5	OSB	7/16" (11)	1.1 (0.16)	R-0.4 (0.07 RSI)	31 (500)	0.45 (1880)
6	Air in Stud Cavity	5 1/2" (140)	-	R-0.9 (0.16 RSI)	0.075 (1.2)	0.24 (1000)
7	2x6 Wood Stud (16" o.c.)	5 1/2" (140)	0.69 (0.10)	-	31 (500)	0.45 (1880)
8	Exterior Plywood Sheathing	1/2" (13)	0.69 (0.10)	-	31 (500)	0.45 (1880)
9	Exterior Insulation	Varies	-	R-10 to R-30 (1.76 to 5.28 RSI)	1.8 (28)	0.29 (1220)
10	Brick Ties	14 gauge	347 (50)	-	489 (7830)	0.12 (500)
11	Exterior Insulation Behind Shelf Angle	Varies	-	R-10 to R-30 (1.76 to 5.28 RSI)	1.8 (28)	0.29 (1220)
12	Flashing	20 gauge	347 (50)	-	489 (7830)	0.12 (500)
13	Steel Shelf Angle	3/8" (10)	347 (50)	-	489 (7830)	0.12 (500)
14	Air Cavity	1 1/2" (38)	-	R-0.4 (0.07 RSI)	0.075 (1.2)	0.24 (1000)
15	Brick Veneer	3 5/8" (92)	5.4 (0.78)	R-0.7 (0.12 RSI)	140 (2250)	0.20 (850)
16	2x4 Wood Truss (16" o.c.)	1 1/2" (38)	0.69 (0.10)	-	31 (500)	0.45 (1880)
17	Air in Floor Cavity	10 3/4" (273)	-	R-0.9 (0.16 RSI)	0.075 (1.2)	0.24 (1000)
18	CLT	5 1/2" (140)	0.83 (0.12)	-	31 (500)	0.45 (1880)
19	Plywood Floor	3/4" (19)	0.69 (0.10)	-	31 (500)	0.45 (1880)
20	Concrete Topping	1 1/2" (38)	12 (1.8)	-	140 (2250)	0.20 (850)
21	Exterior Film ¹	-	-	R-0.2 (0.03 RSI)	-	-

¹ Value selected from table 1, p. 26.1 of 2009 ASHRAE Handbook – Fundamentals depending on surface orientation

Detail 8.2.15

Exterior and Interior Insulated 2x6 Wood Stud (16" o.c.) Wall with Interior OSB and Wood Furring Assembly with Stand-off (Knife Plate) Shelf Angle & Brick Ties Supporting Brick Veneer – CLT and Wood Truss Floor Intersection

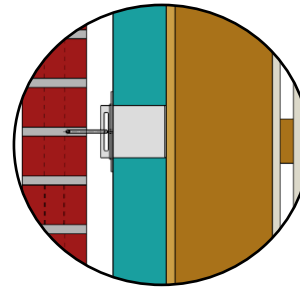
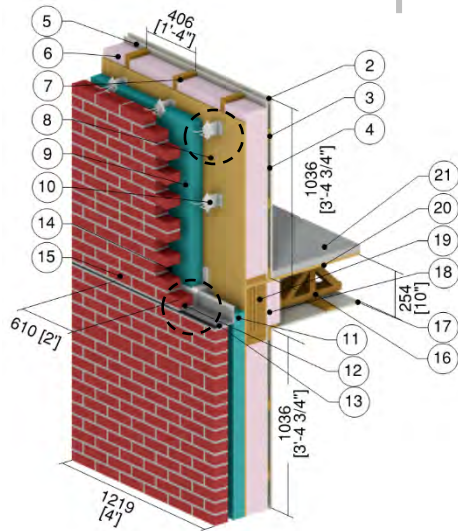

Brick Tie Detail

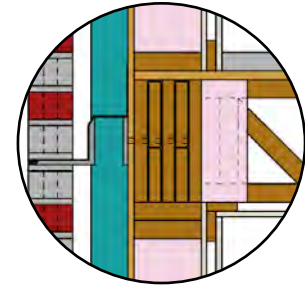

Shelf Angle Detail

ID	Component	Thickness Inches (mm)	Conductivity Btu-in / ft ² ·hr·°F (W/m K)	Nominal Resistance hr·ft ² ·°F/Btu (m ² K/W)	Density lb/ft ³ (kg/m ³)	Specific Heat Btu/lb·°F (J/kg K)
1	Interior Film ¹	-	-	R-0.6 to R-0.9 (0.11 RSI to 0.16 RSI)	-	-
2	Gypsum	1/2" (13)	1.1 (0.16)	R-0.5 (0.08 RSI)	50 (800)	0.26 (1090)
3	1x3 Wood Furring	3/4" (19)	0.7 (0.10)	-	31 (500)	0.45 (1880)
4	Air in Furring Cavity	3/4" (19)	-	R-0.9 (0.16 RSI)	0.075 (1.2)	0.24 (1000)
5	OSB	7/16" (11)	1.1 (0.16)	R-0.4 (0.07 RSI)	31 (500)	0.45 (1880)
6	Fiberglass Batt Insulation in Stud Cavity	5 1/2" (140)	0.29 (0.042)	R-19.0 (3.35 RSI)	0.9 (14)	0.17 (710)
7	2x6 Wood Stud (16" o.c.)	5 1/2" (140)	0.69 (0.10)	-	31 (500)	0.45 (1880)
8	Exterior Plywood Sheathing	1/2" (13)	0.69 (0.10)	-	31 (500)	0.45 (1880)
9	Exterior Insulation	Varies	-	R-5 to R-30 (0.88 to 5.28 RSI)	1.8 (28)	0.29 (1220)
10	Brick Ties	14 gauge	347 (50)	-	489 (7830)	0.12 (500)
11	Exterior Insulation Behind Shelf Angle	Varies	-	R-5 to R-30 (0.88 to 5.28 RSI)	1.8 (28)	0.29 (1220)
12	Flashing	20 gauge	347 (50)	-	489 (7830)	0.12 (500)
13	Steel Shelf Angle	3/8" (10)	347 (50)	-	489 (7830)	0.12 (500)
14	Air Cavity	1 1/2" (38)	-	R-0.4 (0.07 RSI)	0.075 (1.2)	0.24 (1000)
15	Brick Veneer	3 5/8" (92)	5.4 (0.78)	R-0.7 (0.12 RSI)	140 (2250)	0.20 (850)
16	2x4 Wood Truss (16" o.c.)	1 1/2" (38)	0.7 (0.10)	-	31 (500)	0.45 (1880)
17	Air in Floor Cavity	10 3/4" (273)	-	R-0.9 (0.16 RSI)	0.075 (1.2)	0.24 (1000)
18	Fiberglass Batt Insulation at CLT	3 3/4" (95)	0.30 (0.044)	R-12.4 (2.19 RSI)	0.9 (14)	0.17 (710)
19	CLT	10" (254)	0.83 (0.12)	-	31 (500)	0.45 (1880)
20	Plywood Floor	3/4" (19)	0.69 (0.10)	-	31 (500)	0.45 (1880)
21	Concrete Topping	1 1/2" (38)	12 (1.8)	-	140 (2250)	0.20 (850)
22	Exterior Film ¹	-	-	R-0.2 (0.03 RSI)	-	-

¹ Value selected from table 1, p. 26.1 of 2009 ASHRAE Handbook – Fundamentals depending on surface orientation



Detail 8.2.16

Exterior Insulated 2x6 Wood Stud (16" o.c.) Wall with Interior Wood Furring Assembly with Stand-off (Knife Plate) Shelf Angle & Brick Ties Supporting Brick Veneer – CLT and Wood Truss Floor Intersection

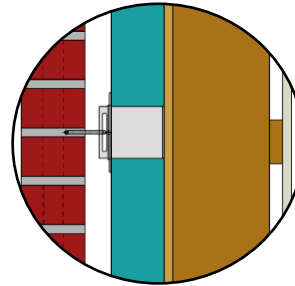
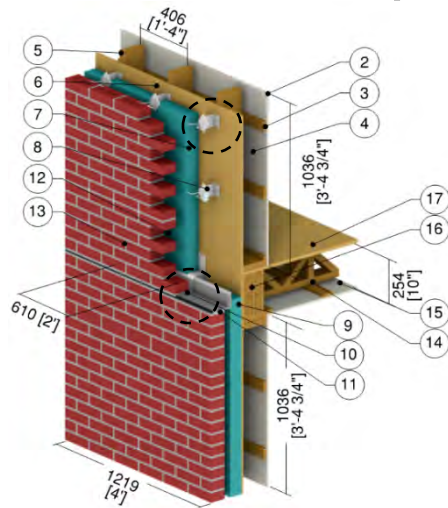

Brick Tie Detail

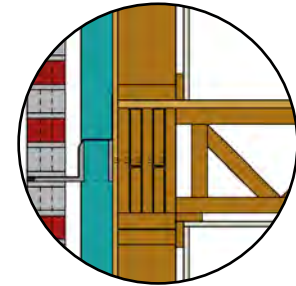

Shelf Angle Detail

ID	Component	Thickness Inches (mm)	Conductivity Btu-in / ft ² ·hr·°F (W/m K)	Nominal Resistance hr·ft ² ·°F/Btu (m ² K/W)	Density lb/ft ³ (kg/m ³)	Specific Heat Btu/lb·°F (J/kg K)
1	Interior Film ¹	-	-	R-0.6 to R-0.9 (0.11 RSI to 0.16 RSI)	-	-
2	Gypsum	1/2" (13)	1.1 (0.16)	R-0.5 (0.08 RSI)	50 (800)	0.26 (1090)
3	1x3 Wood Furring	3/4" (19)	0.69 (0.10)	-	31 (500)	0.45 (1880)
4	Air in Stud Cavity	6 1/4" (159)	-	R-0.9 (0.16 RSI)	0.075 (1.2)	0.24 (1000)
5	2x6 Wood Stud (16" o.c.)	5 1/2" (140)	0.69 (0.10)	-	31 (500)	0.45 (1880)
6	Exterior Plywood Sheathing	1/2" (13)	0.69 (0.10)	-	31 (500)	0.45 (1880)
7	Exterior Insulation	Varies	-	R-10 to R-30 (1.76 to 5.28 RSI)	1.8 (28)	0.29 (1220)
8	Brick Ties	14 gauge	347 (50)	-	489 (7830)	0.12 (500)
9	Exterior Insulation Behind Shelf Angle	Varies	-	R-10 to R-30 (1.76 to 5.28 RSI)	1.8 (28)	0.29 (1220)
10	Flashing	20 gauge	347 (50)	-	489 (7830)	0.12 (500)
11	Steel Shelf Angle	3/8" (10)	347 (50)	-	489 (7830)	0.12 (500)
12	Air Cavity	1 1/2" (38)	-	R-0.4 (0.07 RSI)	0.075 (1.2)	0.24 (1000)
13	Brick Veneer	3 5/8" (92)	5.4 (0.78)	R-0.7 (0.12 RSI)	140 (2250)	0.20 (850)
14	2x4 Wood Truss (16" o.c.)	1 1/2" (38)	0.69 (0.10)	-	31 (500)	0.45 (1880)
15	Air in Floor Cavity	10 3/4" (273)	-	R-0.9 (0.16 RSI)	0.075 (1.2)	0.24 (1000)
16	CLT	10" (254)	0.83 (0.12)	-	31 (500)	0.45 (1880)
17	Plywood Floor	3/4" (19)	0.69 (0.10)	-	31 (500)	0.45 (1880)
18	Exterior Film ¹	-	-	R-0.2 (0.03 RSI)	-	-

¹ Value selected from table 1, p. 26.1 of 2009 ASHRAE Handbook – Fundamentals depending on surface orientation

Detail 8.2.17

Exterior and Interior Insulated 2x6 Wood Stud (16" o.c.) Wall with Interior Wood Furring Assembly with Stand-off (Knife Plate) Shelf Angle & Brick Ties Supporting Brick Veneer – CLT and Wood Truss Floor Intersection

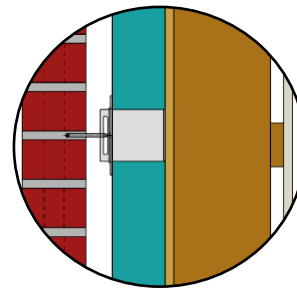
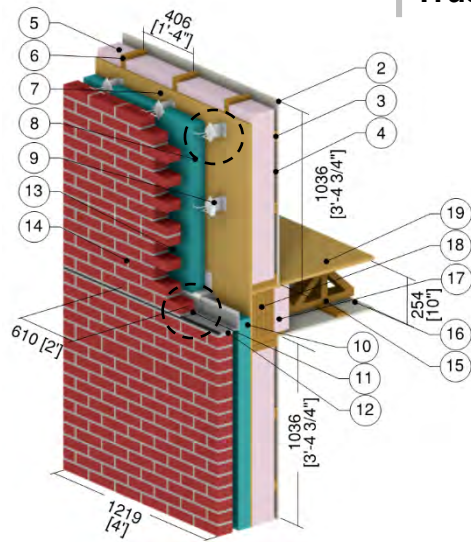

Brick Tie Detail

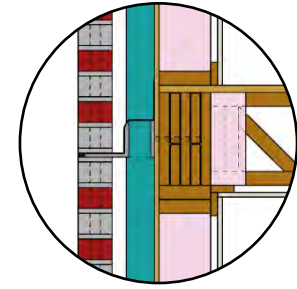

Shelf Angle Detail

ID	Component	Thickness Inches (mm)	Conductivity Btu-in / ft ² -hr-°F (W/m K)	Nominal Resistance hr-ft ² -°F/Btu (m ² K/W)	Density lb/ft ³ (kg/m ³)	Specific Heat Btu/lb-°F (J/kg K)
1	Interior Film ¹	-	-	R-0.6 to R-0.9 (0.11 RSI to 0.16 RSI)	-	-
2	Gypsum	1/2" (13)	1.1 (0.16)	R-0.5 (0.08 RSI)	50 (800)	0.26 (1090)
3	1x3 Wood Furring	3/4" (19)	0.69 (0.10)	-	31 (500)	0.45 (1880)
4	Air in Furring Cavity	3/4" (19)	-	R-0.9 (0.16 RSI)	0.075 (1.2)	0.24 (1000)
5	Fiberglass Batt Insulation in Stud Cavity	5 1/2" (140)	0.29 (0.042)	R-19.0 (3.35 RSI)	0.9 (14)	0.17 (710)
6	2x6 Wood Stud (16" o.c.)	5 1/2" (140)	0.69 (0.10)	-	31 (500)	0.45 (1880)
7	Exterior Plywood Sheathing	1/2" (13)	0.69 (0.10)	-	31 (500)	0.45 (1880)
8	Exterior Insulation	Varies	-	R-5 to R-30 (0.88 to 5.28 RSI)	1.8 (28)	0.29 (1220)
9	Brick Ties	14 gauge	347 (50)	-	489 (7830)	0.12 (500)
10	Exterior Insulation Behind Shelf Angle	Varies	-	R-5 to R-30 (0.88 to 5.28 RSI)	1.8 (28)	0.29 (1220)
11	Flashing	20 gauge	347 (50)	-	489 (7830)	0.12 (500)
12	Steel Shelf Angle	3/8" (10)	347 (50)	-	489 (7830)	0.12 (500)
13	Air Cavity	1 1/2" (38)	-	R-0.4 (0.07 RSI)	0.075 (1.2)	0.24 (1000)
14	Brick Veneer	3 5/8" (92)	5.4 (0.78)	R-0.7 (0.12 RSI)	140 (2250)	0.20 (850)
15	2x4 Wood Truss (16" o.c.)	1 1/2" (38)	0.69 (0.10)	-	31 (500)	0.45 (1880)
16	Air in Floor Cavity	10 3/4" (273)	-	R-0.9 (0.16 RSI)	0.075 (1.2)	0.24 (1000)
17	Fiberglass Batt Insulation at CLT	3 3/4" (95)	0.30 (0.044)	R-12.4 (2.19 RSI)	0.9 (14)	0.17 (710)
18	CLT	10" (254)	0.83 (0.12)	-	31 (500)	0.45 (1880)
19	Plywood Floor	3/4" (19)	0.69 (0.10)	-	31 (500)	0.45 (1880)
20	Exterior Film ¹	-	-	R-0.2 (0.03 RSI)	-	-

¹ Value selected from table 1, p. 26.1 of 2009 ASHRAE Handbook – Fundamentals depending on surface orientation

Detail 8.2.18

Exterior and Interior Insulated 2x6 Wood Stud (8" o.c.) Wall Assembly with Wood Strapping and Continuous Insulation Supporting Rainscreen Fiber Cement Board and R-19 Batt Insulation in Stud Cavity – Intermediate Floor Intersection

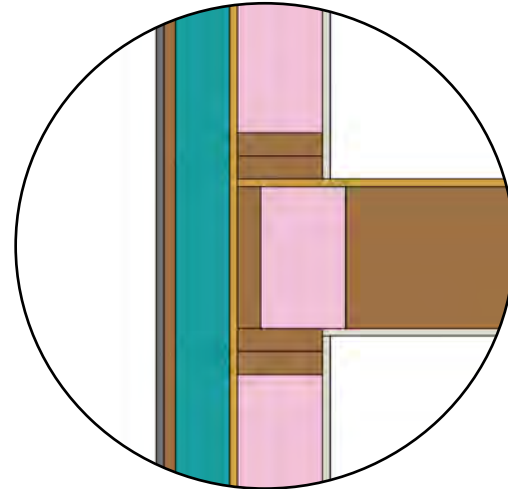
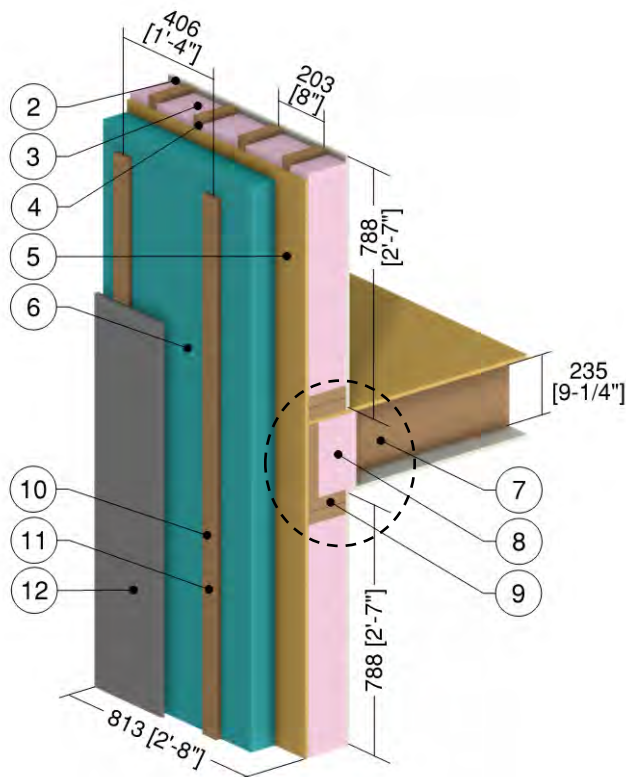

Floor Detail

ID	Component	Thickness Inches (mm)	Conductivity Btu-in / ft ² ·hr·°F (W/m K)	Nominal Resistance hr·ft ² ·°F/Btu (m ² K/W)	Density lb/ft ³ (kg/m ³)	Specific Heat Btu/lb·°F (J/kg K)
1	Interior Films ¹	-	-	R-0.6 to R-0.9 (0.11 RSI to 0.16 RSI)	-	-
2	Gypsum Board	1/2" (13)	1.1 (0.16)	R-0.5 (0.08 RSI)	50 (800)	0.26 (1090)
3	Fiberglass Batt Insulation	5 1/2" (140)	0.29 (0.042)	R-19 (3.3 RSI)	0.9 (14)	0.17 (710)
4	2x6 Wood Stud (8" o.c.)	5 1/2" (140)	0.69 (0.10)	-	31 (500)	0.45 (1880)
5	Exterior Wood Sheathing	1/2" (16)	0.69 (0.10)	R-0.7 (0.12 RSI)	31 (500)	0.45 (1880)
6	Exterior Insulation	Varies	-	R-0 to R-15 (0 RSI to 2.64 RSI)	1.8 (28)	0.29 (1220)
7	2x10 Wood Joist (16" o.c.)	9 1/4" (235)	0.69 (0.10)	-	31 (500)	0.45 (1880)
8	Fiberglass Batt Insulation at Joist	5 1/2" (140)	0.29 (0.042)	R-19 (3.3 RSI)	0.9 (14)	0.17 (710)
9	2x10 Rim Joist	9 1/4" (235)	0.69 (0.10)	-	31 (500)	0.45 (1880)
10	1x3 Wood Strapping	3/4" (19)	0.69 (0.10)	-	31 (500)	0.45 (1880)
11	Steel Fasteners (12" o.c.)	0.44" (11) ∅	347 (50)	-	489 (7830)	0.12 (500)
12	Fiber Cement Board Cladding with 3/4" (19mm) vented airspace incorporated into exterior heat transfer coefficient					
13	Exterior Film ¹	-	-	R-0.7 (0.12 RSI)	-	-

¹ Value selected from table 1, p. 26.1 of 2009 ASHRAE Handbook – Fundamentals depending on surface orientation

Detail 8.2.19

Exterior and Interior Insulated 2x6 Wood Stud (16" o.c.) Wall Assembly with Wood Strapping and Continuous Insulation Supporting Rainscreen Fiber Cement Board and R-19 Batt Insulation in Stud Cavity – Intermediate Floor Intersection

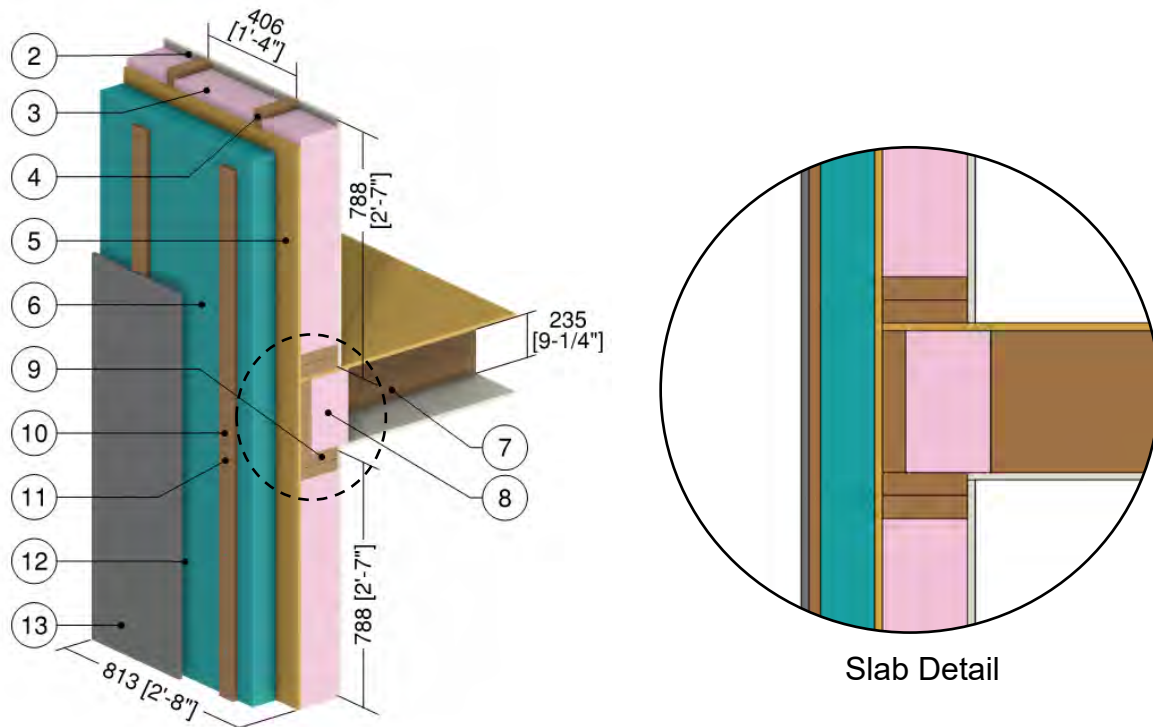

Slab Detail

ID	Component	Thickness Inches (mm)	Conductivity Btu-in / ft ² ·hr·°F (W/m K)	Nominal Resistance hr·ft ² ·°F/Btu (m ² K/W)	Density lb/ft ³ (kg/m ³)	Specific Heat Btu/lb·°F (J/kg K)
1	Interior Films ¹	-	-	R-0.6 to R-0.9 (0.11 RSI to 0.16 RSI)	-	-
2	Gypsum Board	1/2" (13)	1.1 (0.16)	R-0.5 (0.08 RSI)	50 (800)	0.26 (1090)
3	Fiberglass Batt Insulation	5 1/2" (140)	0.29 (0.042)	R-19 (3.3 RSI)	0.9 (14)	0.17 (710)
4	2x6 Wood Stud (16" o.c.)	5 1/2" (140)	0.69 (0.10)	-	31 (500)	0.45 (1880)
5	Exterior Wood Sheathing	1/2" (16)	0.69 (0.10)	R-0.7 (0.12 RSI)	31 (500)	0.45 (1880)
6	Exterior Insulation	Varies	-	R-0 to R-15 (0 RSI to 2.64 RSI)	1.8 (28)	0.29 (1220)
7	2x10 Wood Joist (16" o.c.)	9 1/4" (235)	0.69 (0.10)	-	31 (500)	0.45 (1880)
8	Fiberglass Batt Insulation at Joist	5 1/2" (140)	0.29 (0.042)	R-19 (3.3 RSI)	0.9 (14)	0.17 (710)
9	2x10 Rim Joist	9 1/4" (235)	0.69 (0.10)	-	31 (500)	0.45 (1880)
10	1x3 Wood Strapping	3/4" (19)	0.69 (0.10)	-	31 (500)	0.45 (1880)
11	Steel Fasteners (12" o.c.)	0.44" (11) ∅	347 (50)	-	489 (7830)	0.12 (500)
12	Rainscreen Cavity	3/4" (19)	-	R-0.5 (0.09 RSI)	0.075 (1.2)	0.24 (1000)
13	Fiber Cement Board Cladding	1/2" (13)	4.9 (0.7)	R-0.1 (0.02 RSI)	112 (1800)	0.20 (840)
14	Exterior Film ¹	-	-	R-0.7 (0.12 RSI)	-	-

¹ Value selected from table 1, p. 26.1 of 2009 ASHRAE Handbook – Fundamentals depending on surface orientation

Detail 8.3.1

Exterior and Interior Insulated 2x6 Wood Stud (16" o.c.) Wall Assembly with Wood Strapping and Continuous Insulation Supporting Rainscreen Fiber Cement Board – Vinyl Window Intersection

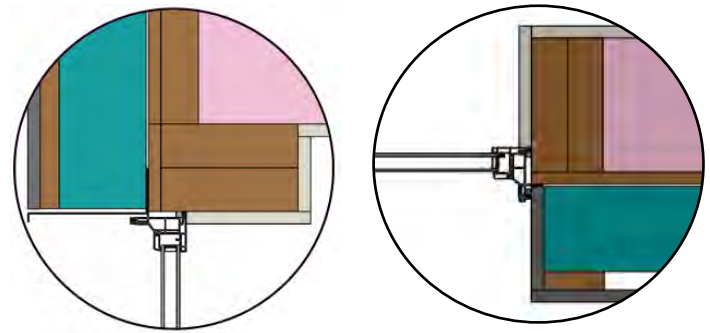
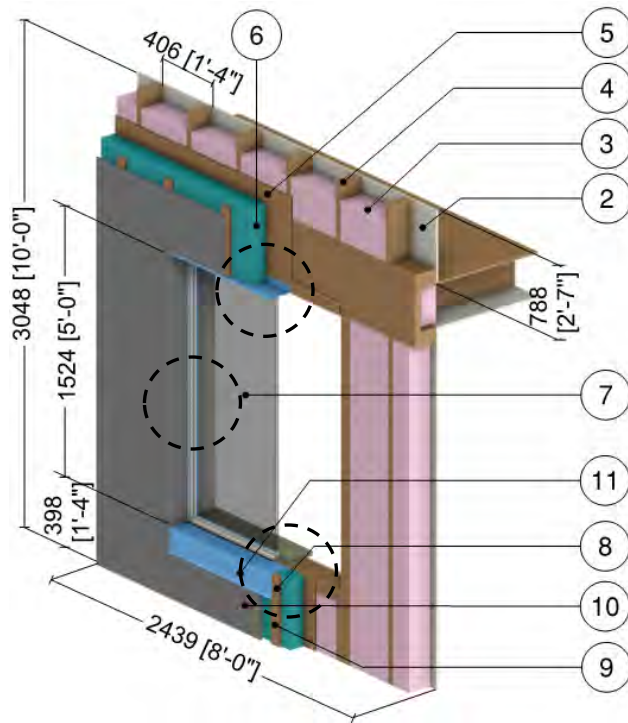

Head Detail

Jamb Detail

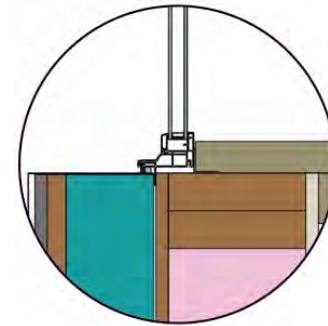

Sill Detail

ID	Component	Thickness Inches (mm)	Conductivity Btu·in / ft ² ·hr·°F (W/m K)	Nominal Resistance hr·ft ² ·°F/Btu (m ² K/W)	Density lb/ft ³ (kg/m ³)	Specific Heat Btu/lb·°F (J/kg K)
1	Interior Film ¹	-	-	R-0.6 to R-0.9 (0.11 RSI to 0.16 RSI)	-	-
2	Gypsum Board	1/2" (13)	1.1 (0.16)	R-0.5 (0.08 RSI)	50 (800)	0.26 (1090)
3	Fiberglass Batt Insulation	5 1/2" (140)	0.29 (0.042)	R-19 (3.3 RSI)	0.9 (14)	0.17 (710)
4	2x6 Wood Stud (16" o.c.)	5 1/2" (140)	0.69 (0.10)	-	31 (500)	0.45 (1880)
5	Exterior Wood Sheathing	1/2" (16)	0.69 (0.10)	R-0.7 (0.12 RSI)	31 (500)	0.45 (1880)
6	Exterior Insulation	Varies	-	R-5 to R-15 (0.88 RSI to 2.64 RSI)	1.8 (28)	0.29 (1220)
7	5' (1.5m) x 6' (1.8m) Vinyl window: double glazed & thermally broken ² , double glazed IGU U _{IGU} = 0.32 BTU/hr·ft ² ·°F (1.82 W/m ² K)					
8	1x3 Wood Strapping	3/4" (19)	0.69 (0.10)	-	31 (500)	0.45 (1880)
9	Steel Fasteners (16" o.c.)	0.35" (9) Ø	430 (50)	-	489 (7830)	0.12 (500)
10	Fiber Cement Board Cladding with 3/4" (19mm) vented airspace incorporated into exterior heat transfer coefficient					
11	Aluminum Flashing	18 Gauge	1109 (160)	-	171(2739)	0.21 (900)
12	Exterior Film ¹	-	-	R-0.2 to R-0.7 (0.03 RSI to 0.12 RSI)	-	-

¹ Value selected from table 1, p. 26.1 of 2009 ASHRAE Handbook – Fundamentals depending on surface orientation

² The thermal conductivity for air spaces within window framing was found using ISO 10077-2

Detail 8.3.2

Exterior and Interior Insulated 2x6 Wood Stud (16" o.c.) Wall Assembly with Wood Strapping and Continuous Insulation Supporting Rainscreen Fiber Cement Board – Aluminum Window Intersection

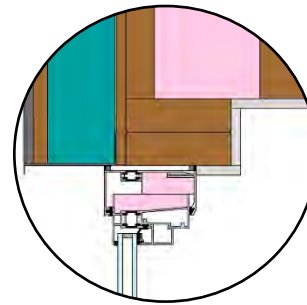
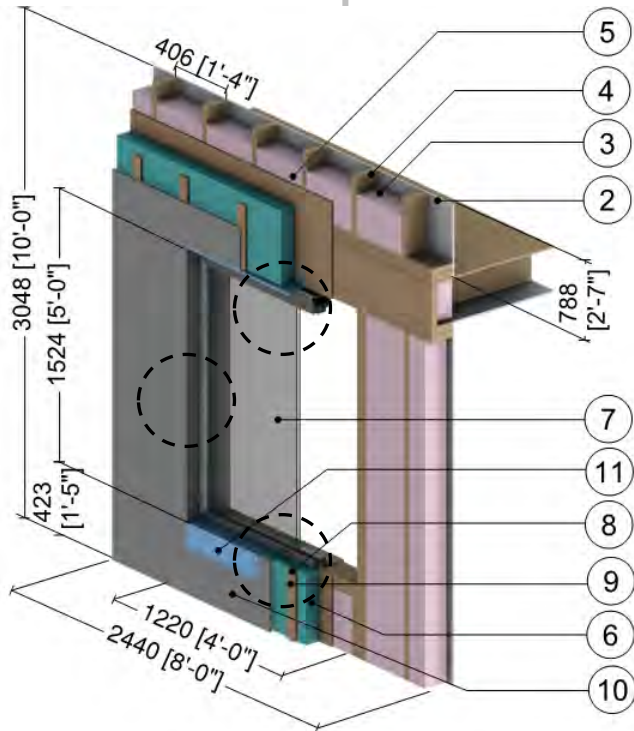

Head Detail

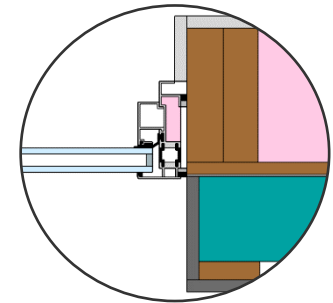

Jamb Detail

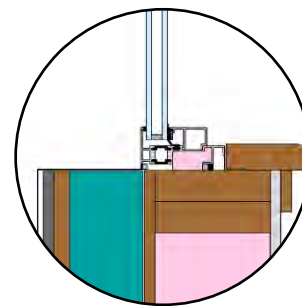

Sill Detail

ID	Component	Thickness Inches (mm)	Conductivity Btu·in / ft ² ·hr·°F (W/m K)	Nominal Resistance hr·ft ² ·°F/Btu (m ² K/W)	Density lb/ft ³ (kg/m ³)	Specific Heat Btu/lb·°F (J/kg K)
1	Interior Film ¹	-	-	R-0.6 to R-0.9 (0.11 RSI to 0.16 RSI)	-	-
2	Gypsum Board	1/2" (13)	1.1 (0.16)	R-0.5 (0.08 RSI)	50 (800)	0.26 (1090)
3	Fiberglass Batt Insulation	5 1/2" (140)	-	R-19 (3.3 RSI)	0.9 (14)	0.17 (710)
4	2x6 Wood Stud (16" o.c.)	5 1/2" (140)	0.69 (0.10)	-	31 (500)	0.45 (1880)
5	Exterior Wood Sheathing	1/2" (13)	0.69 (0.10)	R-0.7 (0.12 RSI)	31 (500)	0.45 (1880)
6	Exterior Insulation	Varies	-	R-0 to R-15 (0 RSI to 2.64 RSI)	1.8 (28)	0.29 (1220)
7	5' (1.5m) x 6' (1.8m) Aluminum window: double glazed & thermally broken ² , double glazed IGU UIGU = 0.32 BTU/hr.ft ² ·°F (1.82 W/m ² K)					
8	1x3 Wood Strapping	3/4" (19)	0.69 (0.10)	-	31 (500)	0.45 (1880)
9	Steel Fasteners (16" o.c.)	0.35" (9) Ø	347 (50)	-	489 (7830)	0.12 (500)
10	Fiber Cement Board Cladding with 3/4" (19mm) vented airspace incorporated into exterior heat transfer coefficient					
11	Aluminum Flashing	18 Gauge	1109 (160)	-	171(2739)	0.21 (900)
12	Exterior Film ¹	-	-	R-0.2 to R-0.7 (0.03 RSI to 0.12 RSI)	-	-

¹ Value selected from table 1, p. 26.1 of 2009 ASHRAE Handbook – Fundamentals depending on surface orientation

² The thermal conductivity for air spaces within window framing was found using ISO 10077-2

Detail 8.3.3

Exterior and Interior Insulated 2x6 Wood Stud (8" o.c.) Wall Assembly with Wood Strapping and Continuous Insulation Supporting Rainscreen Fiber Cement Board – Vinyl Window Intersection

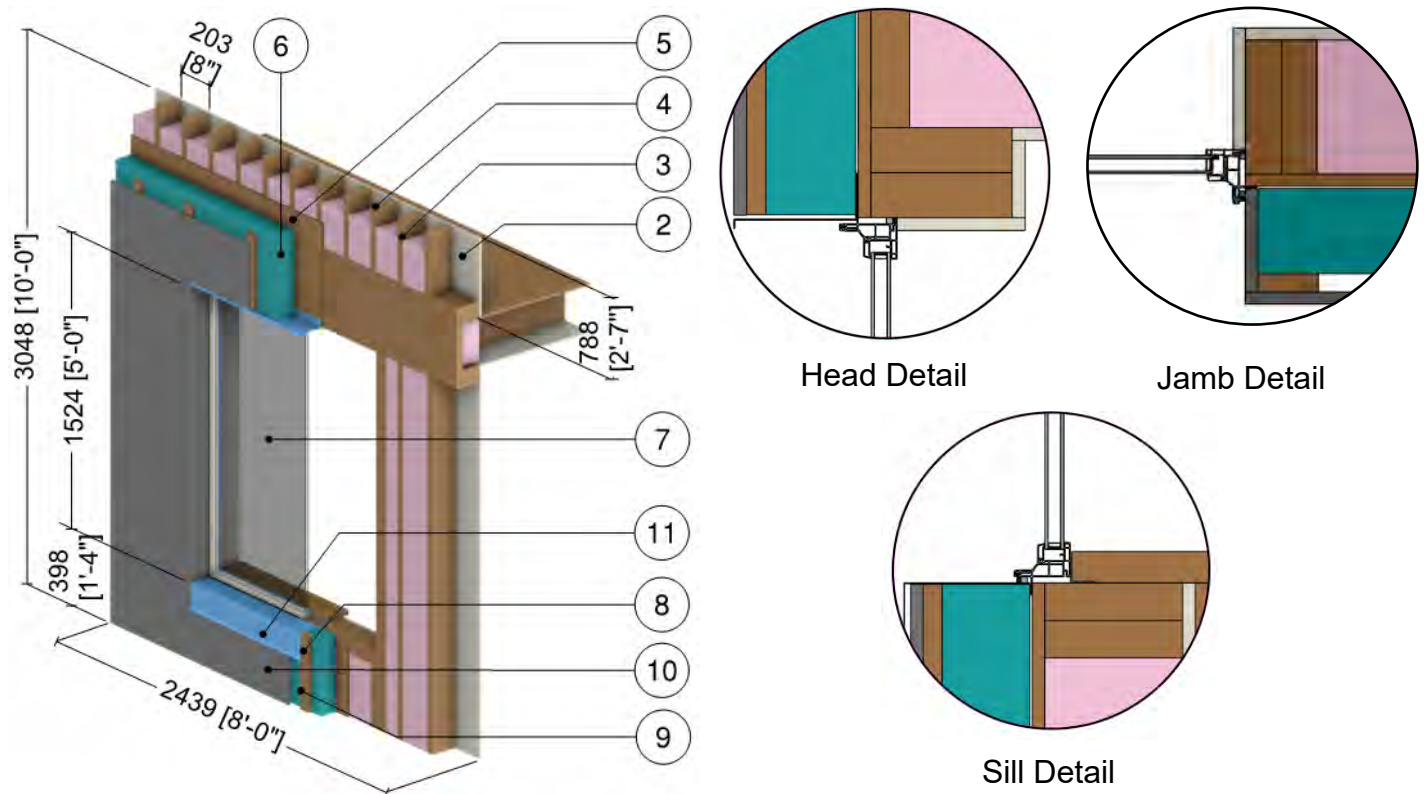

ID	Component	Thickness Inches (mm)	Conductivity Btu-in / ft ² ·hr·°F (W/m K)	Nominal Resistance hr·ft ² ·°F/Btu (m ² K/W)	Density lb/ft ³ (kg/m ³)	Specific Heat Btu/lb·°F (J/kg K)
1	Interior Films ¹	-	-	R-0.9 to R-1.1 (0.16 RSI to 0.2 RSI)	-	-
2	Gypsum Board	1/2" (13)	1.1 (0.16)	R-0.5 (0.08 RSI)	50 (800)	0.26 (1090)
3	Fiberglass Batt Insulation	5 1/2" (140)	0.29 (0.042)	R-19 (3.3 RSI)	0.9 (14)	0.17 (710)
4	2x6 Wood Stud (8" o.c.)	5 1/2" (140)	0.69 (0.10)	-	31 (500)	0.45 (1880)
5	Exterior Wood Sheathing	1/2" (16)	0.69 (0.10)	R-0.7 (0.12 RSI)	31 (500)	0.45 (1880)
6	Exterior Insulation	Varies	-	R-0 to R-15 (0 RSI to 2.64 RSI)	1.8 (28)	0.29 (1220)
7	5' (1.5m) x 6' (1.8m) Vinyl window: double glazed & thermally broken ² , double glazed IGU U _{IGU} = 0.32 BTU/hr·ft ² ·°F (1.82 W/m ² K)					
8	1x3 Wood Strapping	3/4" (19)	0.69 (0.10)	-	31 (500)	0.45 (1880)
9	Steel Fasteners (16" o.c.)	0.35" (9) ∅	347 (50)	-	489 (7830)	0.12 (500)
10	Fiber Cement Board Cladding with 3/4" (19mm) vented airspace incorporated into exterior heat transfer coefficient					
11	Aluminum Flashing	18 Gauge	1109 (160)	-	171 (2739)	0.21 (900)
12	Exterior Film ¹	-	-	R-0.2 to R-0.7 (0.03 RSI to 0.12 RSI)	-	-

¹ Value selected from table 1, p. 26.1 of 2009 ASHRAE Handbook – Fundamentals depending on surface orientation

² The thermal conductivity of air spaces within framing was found using ISO 100077-2

Detail 8.3.4

Exterior Insulated 2x6 Wood Stud (16" o.c.) Wall Assembly with Wood Strapping and Continuous Insulation Supporting Rainscreen Fiber Cement Board – Triple Glazed Flange Mounted Vinyl Window Intersection with Window Positioned in Wood Framing

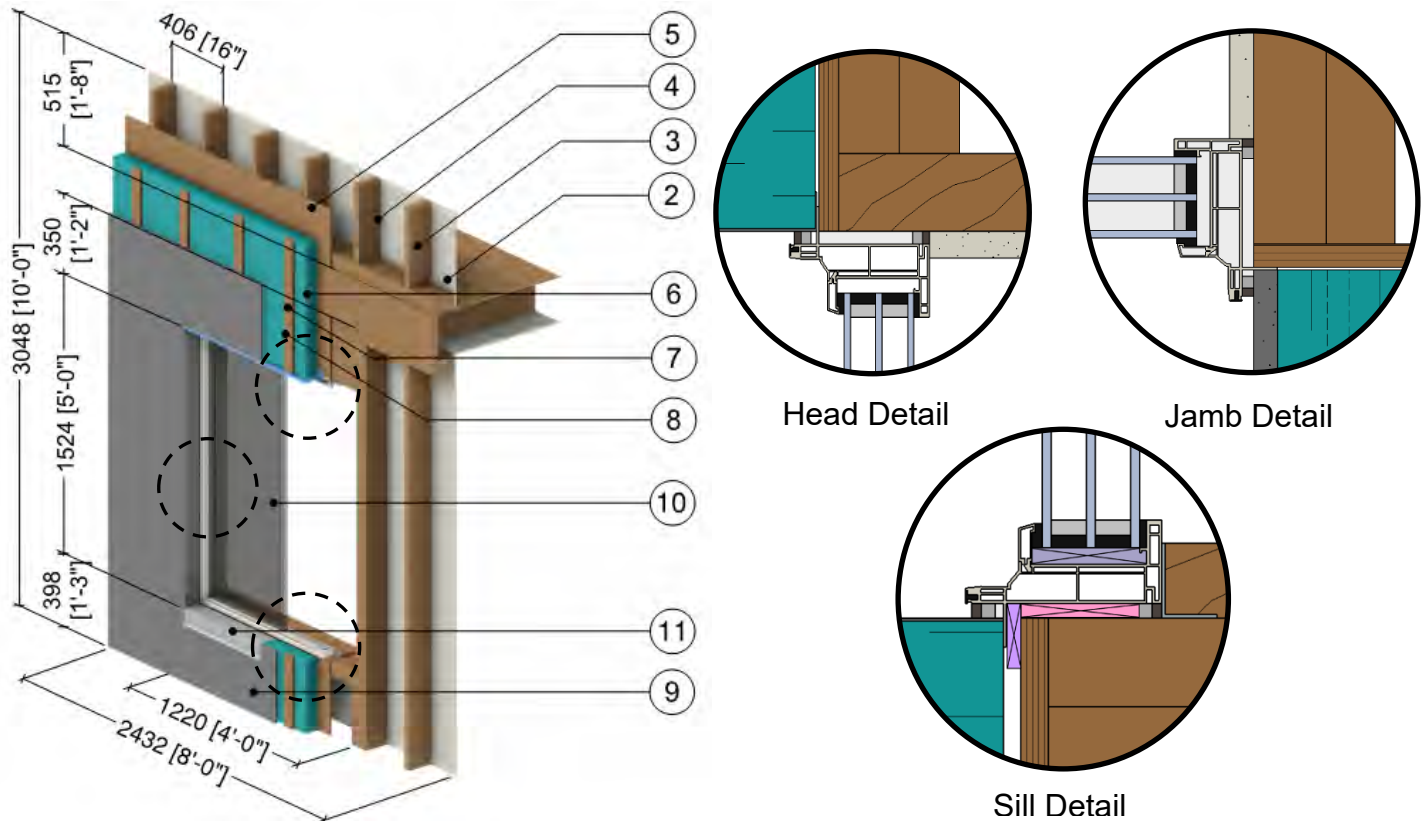

ID	Component	Thickness Inches (mm)	Conductivity Btu-in / ft ² ·hr·°F (W/m K)	Nominal Resistance hr·ft ² ·°F/Btu (m ² K/W)	Density lb/ft ³ (kg/m ³)	Specific Heat Btu/lb·°F (J/kg K)
1	Interior Film ¹	-	-	R-0.6 to R-0.9 (0.11 RSI to 0.16 RSI)	-	-
2	Gypsum Board	1/2" (13)	1.1 (0.16)	R-0.5 (0.08 RSI)	50 (800)	0.26 (1090)
3	2x6 Wood Stud (16" o.c.)	5 1/2" (140)	0.69 (0.10)	-	31 (500)	0.45 (1880)
4	Air in Stud Cavity	5 1/2" (140)	-	R-0.9 (0.16 RSI)	0.075 (1.2)	0.24 (1000)
5	Exterior Wood Sheathing	1/2" (13)	0.69 (0.10)	-	31 (500)	0.45 (1880)
6	Exterior Insulation	Varies	-	R-5 to R-15 (0.88 RSI to 2.64 RSI)	1.8 (28)	0.29 (1220)
7	1x3 Wood Strapping	3/4" (19)	0.69 (0.10)	-	31 (500)	0.45 (1880)
8	Steel Fasteners (16" o.c.)	0.35" (9) ∅	347 (50)	-	489 (7830)	0.12 (500)
9	Fiber Cement Board Cladding with 3/4" (19mm) vented air space is incorporated into exterior heat transfer coefficient					
10	5' (1.5m) x 4' (1.2m) Vinyl window: triple glazed ² , IGU U _{IGU} = 0.14 BTU/hr.ft ² ·°F (0.81 W/m ² K)					
11	Aluminum Flashing	14 Gauge	1110 (160)	-	171 (2739)	0.21 (900)
12	Exterior Film ¹	-	-	R-0.2 to R-0.7 (0.03 RSI to 0.12 RSI)	-	-

¹ Value selected from table 1, p. 26.1 of 2009 ASHRAE Handbook – Fundamentals depending on surface orientation

² The thermal conductivity of air spaces within framing was found using ISO 100077-2

Detail 8.3.5

Exterior and Interior Insulated 2x6 Wood Stud (16" o.c.) Wall Assembly with Wood Strapping and Continuous Insulation Supporting Rainscreen Fiber Cement Board and R-19 Batt Insulation in Stud Cavity – Triple Glazed Flange Mounted Vinyl Window Intersection with Window Positioned in Wood Framing

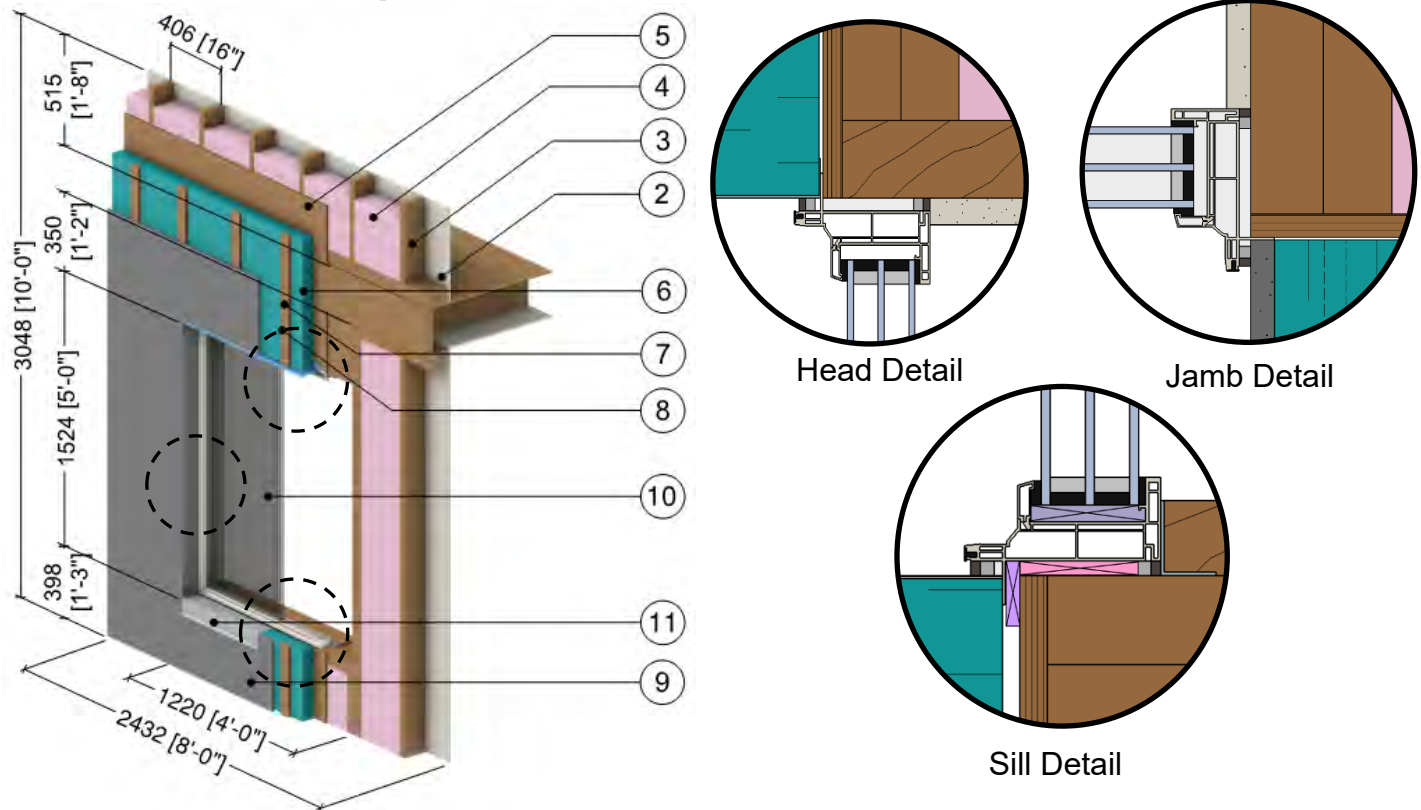

ID	Component	Thickness Inches (mm)	Conductivity Btu-in / ft ² ·hr·°F (W/m K)	Nominal Resistance hr·ft ² ·°F/Btu (m ² K/W)	Density lb/ft ³ (kg/m ³)	Specific Heat Btu/lb·°F (J/kg K)
1	Interior Film ¹	-	-	R-0.6 to R-0.9 (0.11 RSI to 0.16 RSI)	-	-
2	Gypsum Board	1/2" (13)	1.1 (0.16)	R-0.5 (0.08 RSI)	50 (800)	0.26 (1090)
3	2x6 Wood Stud (16" o.c.)	5 1/2" (140)	0.69 (0.10)	-	31 (500)	0.45 (1880)
4	Fiberglass Batt Insulation	5 1/2" (140)	-	R-19 (3.3 RSI)	0.9 (14)	0.17 (710)
5	Exterior Wood Sheathing	1/2" (13)	0.69 (0.10)	-	31 (500)	0.45 (1880)
6	Exterior Insulation	Varies	-	R-5 to R-15 (0.88 RSI to 2.64 RSI)	1.8 (28)	0.29 (1220)
7	1x3 Wood Strapping	3/4" (19)	0.69 (0.10)	-	31 (500)	0.45 (1880)
8	Steel Fasteners (16" o.c.)	0.35" (9) ∅	347 (50)	-	489 (7830)	0.12 (500)
9	Fiber Cement Board Cladding with 3/4" (19mm) vented air space is incorporated into exterior heat transfer coefficient					
10	5' (1.5m) x 4' (1.2m) Vinyl window: triple glazed ² , IGU U _{IGU} = 0.14 BTU/hr.ft ² ·°F (0.81 W/m ² K)					
11	Aluminum Flashing	14 Gauge	1110 (160)	-	171 (2739)	0.21 (900)
12	Exterior Film ¹	-	-	R-0.2 to R-0.7 (0.03 RSI to 0.12 RSI)	-	-

¹ Value selected from table 1, p. 26.1 of 2009 ASHRAE Handbook – Fundamentals depending on surface orientation

² The thermal conductivity of air spaces within framing was found using ISO 100077-2



Detail 8.3.6

Exterior Insulated 2x6 Wood Stud (16" o.c.) Wall Assembly with Wood Strapping (16" o.c.) and Continuous Insulation Supporting Rainscreen Fiber Cement Board – Triple Glazed High Performance Vinyl Window Intersection (Insulated Frames)

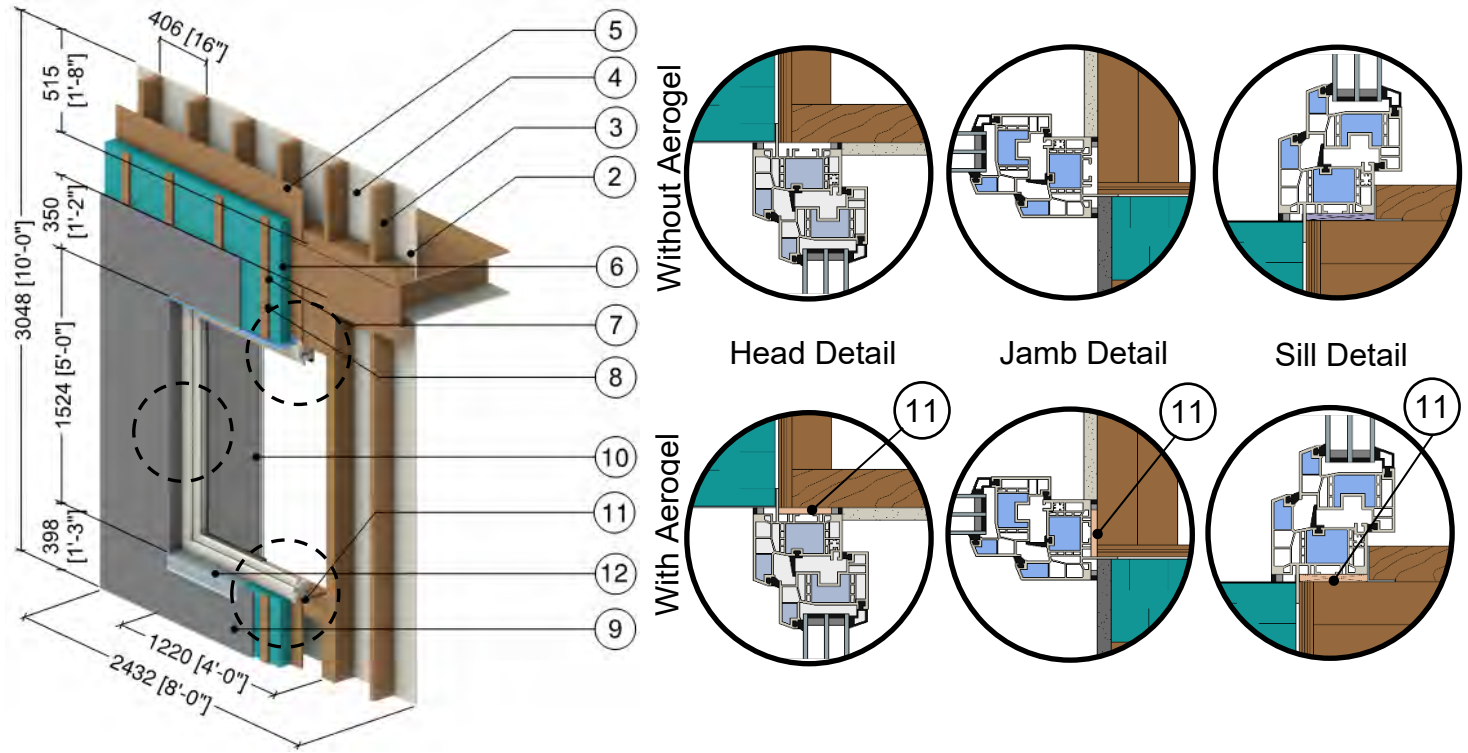

ID	Component	Thickness Inches (mm)	Conductivity Btu-in / ft ² -hr-°F (W/m K)	Nominal Resistance hr-ft ² -°F/Btu (m ² K/W)	Density lb/ft ³ (kg/m ³)	Specific Heat Btu/lb-°F (J/kg K)
1	Interior Film ¹	-	-	R-0.6 to R-0.9 (0.11 RSI to 0.16 RSI)	-	-
2	Gypsum Board	1/2" (13)	1.1 (0.16)	R-0.5 (0.08 RSI)	50 (800)	0.26 (1090)
3	2x6 Wood Stud (16" o.c.)	5 1/2" (140)	0.69 (0.10)	-	31 (500)	0.45 (1880)
4	Air in Stud Cavity	5 1/2" (140)	-	R-0.9 (0.16 RSI)	0.075 (1.2)	0.24 (1000)
5	Exterior Wood Sheathing	1/2" (13)	0.69 (0.10)	-	31 (500)	0.45 (1880)
6	Exterior Insulation	Varies	-	R-5 to R-15 (0.88 RSI to 2.64 RSI)	1.8 (28)	0.29 (1220)
7	1x3 Wood Strapping	3/4" (19)	0.69 (0.10)	-	31 (500)	0.45 (1880)
8	Steel Fasteners (16" o.c.)	0.35" (9) ∅	347 (50)	-	489 (7830)	0.12 (500)
9	Fiber Cement Board Cladding with 3/4" (19mm) vented air space is incorporated into exterior heat transfer coefficient					
10	5' (1.5m) x 4' (1.2m) Vinyl window (Passive House certified) ² : triple glazed, IGU U _{IGU} = 0.14 BTU/hr.ft ² .°F (0.81 W/m ² K)					
11	Aerogel Blanket	0.4" (10)	0.086 (0.015)	R-3.8 (0.67 RSI)	-	-
12	Aluminum Flashing	14 Gauge	1110 (160)	-	171 (2739)	0.21 (900)
13	Exterior Film ¹	-	-	R-0.2 to R-0.7 (0.03 RSI to 0.12 RSI)	-	-

¹ Value selected from table 1, p. 26.1 of 2009 ASHRAE Handbook – Fundamentals depending on surface orientation

² The thermal conductivity of air spaces within framing was found using ISO 100077-2

Detail 8.3.7

Exterior and Interior Insulated 2x6 Wood Stud (16" o.c.) Wall Assembly with Wood Strapping (16" o.c.) and Continuous Insulation Supporting Rainscreen Fiber Cement Board and R-19 Batt Insulation in Stud Cavity – Triple Glazed High Performance Vinyl Window Intersection (Insulated Frames)

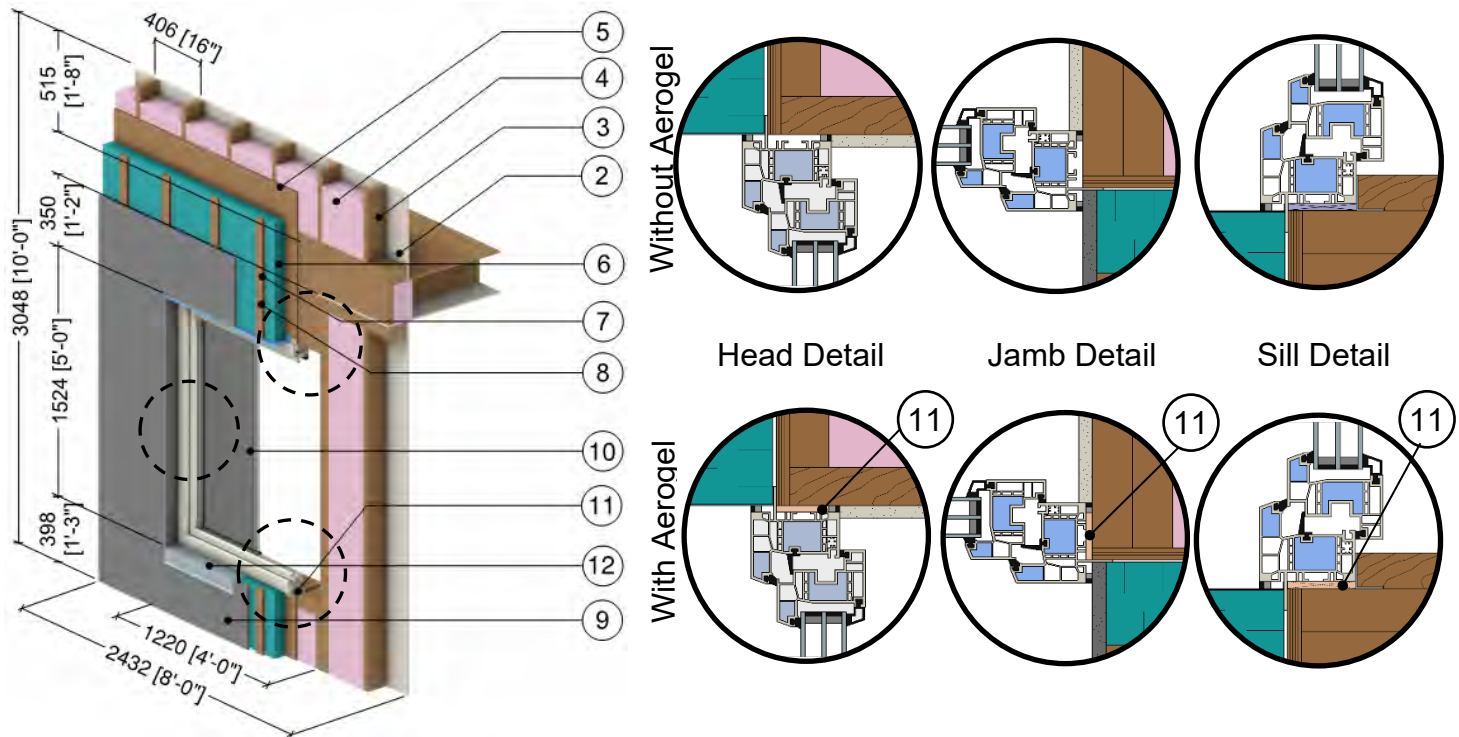

ID	Component	Thickness Inches (mm)	Conductivity Btu-in / ft ² -hr-°F (W/m K)	Nominal Resistance hr-ft ² -°F/Btu (m ² K/W)	Density lb/ft ³ (kg/m ³)	Specific Heat Btu/lb-°F (J/kg K)
1	Interior Film ¹	-	-	R-0.6 to R-0.9 (0.11 RSI to 0.16 RSI)	-	-
2	Gypsum Board	1/2" (13)	1.1 (0.16)	R-0.5 (0.08 RSI)	50 (800)	0.26 (1090)
3	2x6 Wood Stud (16" o.c.)	5 1/2" (140)	0.69 (0.10)	-	31 (500)	0.45 (1880)
4	Fiberglass Batt Insulation	5 1/2" (140)	-	R-19 (3.3 RSI)	0.9 (14)	0.17 (710)
5	Exterior Wood Sheathing	1/2" (13)	0.69 (0.10)	-	31 (500)	0.45 (1880)
6	Exterior Insulation	Varies	-	R-5 to R-15 (0.88 RSI to 2.64 RSI)	1.8 (28)	0.29 (1220)
7	1x3 Wood Strapping	3/4" (19)	0.69 (0.10)	-	31 (500)	0.45 (1880)
8	Steel Fasteners (16" o.c.)	0.35" (9) ∅	347 (50)	-	489 (7830)	0.12 (500)
9	Fiber Cement Board Cladding with 3/4" (19mm) vented air space is incorporated into exterior heat transfer coefficient					
10	5' (1.5m) x 4' (1.2m) Vinyl window (Passive House certified) ² : triple glazed, IGU U _{IGU} = 0.14 BTU/hr.ft ² .°F (0.81 W/m ² K)					
11	Aerogel Blanket	0.4" (10)	0.086 (0.015)	R-3.8 (0.67 RSI)	-	-
12	Aluminum Flashing	14 Gauge	1110 (160)	-	171 (2739)	0.21 (900)
13	Exterior Film ¹	-	-	R-0.2 to R-0.7 (0.03 RSI to 0.12 RSI)	-	-

¹ Value selected from table 1, p. 26.1 of 2009 ASHRAE Handbook – Fundamentals depending on surface orientation

² The thermal conductivity of air spaces within framing was found using ISO 100077-2



Detail 8.3.8

Interior Insulated Cross Laminated Timber (CLT) Spandrel at Window and Dowel Laminated Timber (DLT) – Intermediate Floor Intersection with Edge of Floor and Glulam Beam Aligned

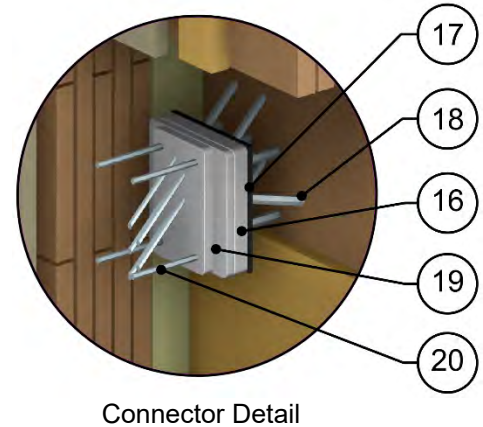
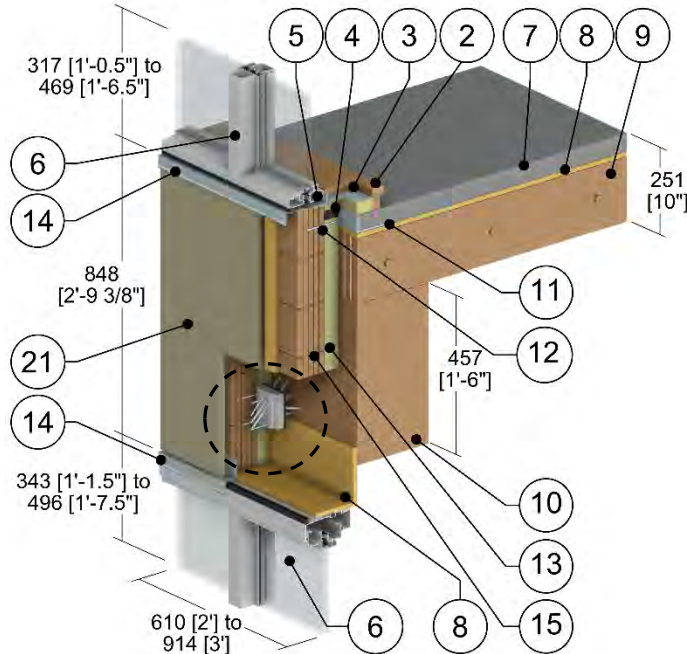

ID	Component	Thickness Inches (mm)	Conductivity Btu-in / ft ² ·hr·°F (W/m K)	Nominal Resistance hr·ft ² ·°F/Btu (m ² K/W)	Density lb/ft ³ (kg/m ³)	Specific Heat Btu/lb·°F (J/kg K)
1	Interior Film ¹	-	-	R-0.6 to R-1.1 (0.11 RSI to 0.20 RSI)	-	-
2	Wood Sill	1" (25)	0.69 (0.10)	-	31 (500)	0.45 (1880)
3	Support Angle	18 Gauge	430 (62)	-	489 (7830)	0.12 (500)
4	Firestop Sealant	1" (25)	2.4 (0.35)	-	174 (2800)	0.17 (700)
5	Window Mounting Angle	1/8" (3)	1110 (160)	-	171 (2740)	0.21 (900)
6	Aluminum Window Wall Vision System ² : thermally broken frame, double glazed IGU U _{IGU} = 0.32 BTU/hr·ft ² ·°F (1.82 W/m ² K)					
7	Concrete Topping	2" (51)	12.5 (1.8)	-	140 (2250)	0.20 (850)
8	Plywood	5/8" (16)	0.69 (0.10)	-	31 (500)	0.45 (1880)
9	DLT Floor	7 1/4" (184)	0.83 (0.12)	-	31 (500)	0.45 (1880)
10	Glulam Beam	9.5" (241)	0.97 (0.14)	R-9.8 (1.73 RSI)	31 (500)	0.45 (1880)
11	L-angle	1/4" (6)	347 (50)	-	489 (7830)	0.12 (500)
12	Structural Screws 18" o.c.	ø 5/16" (8)	347 (50)	-	489 (7830)	0.12 (500)
13	Mineral Wool Insulation	Varies	0.24 (0.034)	R-8.4 to R-33.6 (1.48 RSI to 5.92 RSI)	4 (64)	0.20 (850)
14	Aluminum Flashing	14 Gauge	1110 (160)	-	171 (2740)	0.21 (900)
15	CLT Panel	3.5" (89)	0.83 (0.12)	R-4.2 (0.79 RSI)	31 (500)	0.45 (1880)
16	ISO-CONNECT Plate	19/32" (15)	1110 (160)	-	171 (2740)	0.21 (900)
17	ISO-CONNECT Rubber Pad	1/8" (3)	1.7 (0.25)	-	-	-
18	ISO-CONNECT Fasteners x12	ø 5/16" (8)	347 (50)	-	489 (7830)	0.12 (500)
19	HVP Coupling Plates	19/32" (15)	1110 (160)	-	171 (2740)	0.21 (900)
20	HVP Fasteners x9	ø 3/16" (5)	347 (50)	-	489 (7830)	0.12 (500)
21	Fiber Cement Board Cladding with 3/4" (19mm) vented airspace incorporated into exterior heat transfer coefficient					
22	Exterior Film ¹	-	-	R-0.2 to R-0.7 (0.03 RSI to 0.12 RSI)	-	-

¹ Value selected from table 1, p. 26.1 of 2009 ASHRAE Handbook – Fundamentals depending on surface orientation

² The thermal conductivity of air spaces within framing was found using ISO 100077-2

Detail 8.3.9

Full Height Interior Insulated Cross Laminated Timber (CLT) Spandrel at Window and Dowel Laminated Timber (DLT) – Intermediate Floor Intersection with Edge of Floor and Glulam Beam Aligned

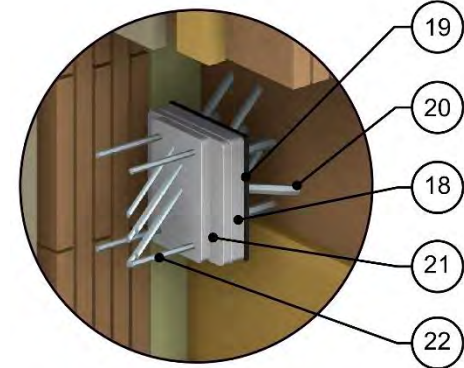
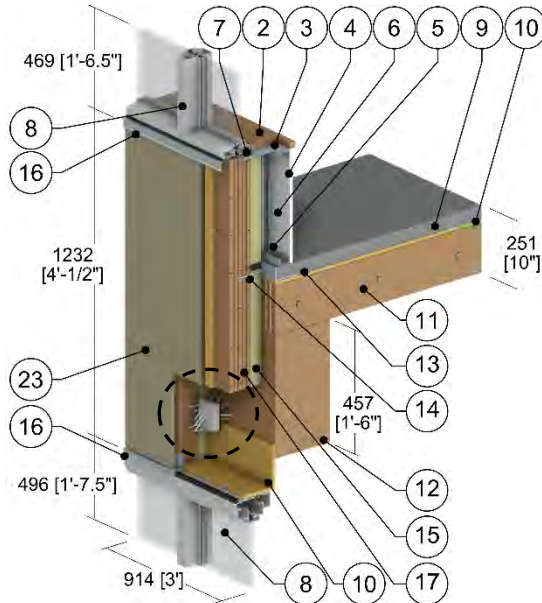

Connector Detail

ID	Component	Thickness Inches (mm)	Conductivity Btu-in / ft ² -hr-°F (W/m K)	Nominal Resistance hr-ft ² -°F/Btu (m ² K/W)	Density lb/ft ³ (kg/m ³)	Specific Heat Btu/lb-°F (J/kg K)
1	Interior Film ¹	-	-	R-0.6 to R-1.1 (0.11 RSI to 0.20 RSI)	-	-
2	Wood Sill	1" (25)	0.69 (0.10)	-	31 (500)	0.45 (1880)
3	Support Angle	18 Gauge	430 (62)	-	489 (7830)	0.12 (500)
4	Gypsum Board	1/2" (13)	1.1 (0.16)	R-0.5 (0.08 RSI)	50 (800)	0.26 (1090)
5	Steel Studs (16" o.c.) and Tracks	18 Gauge	430 (62)	-	489 (7830)	0.12 (500)
6	Air Cavity	2.5" (64)	-	R-0.9 (0.16 RSI)	0.075 (1.2)	0.24 (1000)
7	Window Mounting Angle	1/8" (3)	1110 (160)	-	171 (2740)	0.21 (900)
8	Aluminum Window Wall Vision System ² : thermally broken frame, double glazed IGU U _{IGU} = 0.32 BTU/hr-ft ² -°F (1.82 W/m ² K)					
9	Concrete Topping	2" (51)	12.5 (1.8)	-	140 (2250)	0.20 (850)
10	Plywood	5/8" (16)	0.69 (0.10)	-	31 (500)	0.45 (1880)
11	DLT Floor	7 1/4" (184)	0.83 (0.12)	-	31 (500)	0.45 (1880)
12	Glulam Beam	9.5" (241)	0.97 (0.14)	R-9.8 (1.73 RSI)	31 (500)	0.45 (1880)
13	L-Angle	1/4" (6)	347 (50)	-	489 (7830)	0.12 (500)
14	Structural Screws 18" o.c.	ø 5/16" (8)	347 (50)	-	489 (7830)	0.12 (500)
15	Mineral Wool Insulation	Varies	0.24 (0.034)	R-8.4 to R-33.6 (1.48 RSI to 5.92 RSI)	4 (64)	0.20 (850)
16	Aluminum Flashing	14 Gauge	1110 (160)	-	171 (2740)	0.21 (900)
17	CLT Panel	3.5" (89)	0.83 (0.12)	R-4.2 (0.79 RSI)	31 (500)	0.45 (1880)
18	ISO-CONNECT Plate	19/32" (15)	1110 (160)	-	171 (2740)	0.21 (900)
19	ISO-CONNECT Rubber Pad	1/8" (3)	1.7 (0.25)	-	-	-
20	ISO-CONNECT Fasteners x12	ø 5/16" (8)	347 (50)	-	489 (7830)	0.12 (500)
21	HVP Coupling Plates	19/32" (15)	1110 (160)	-	171 (2740)	0.21 (900)
22	HVP Fasteners x9	ø 3/16" (5)	347 (50)	-	489 (7830)	0.12 (500)
23	Fiber Cement Board Cladding with 3/4" (19mm) vented airspace incorporated into exterior heat transfer coefficient					
24	Exterior Film ¹	-	-	R-0.2 to R-0.7 (0.03 RSI to 0.12 RSI)	-	-

¹ Value selected from table 1, p. 26.1 of 2009 ASHRAE Handbook – Fundamentals depending on surface orientation

² The thermal conductivity of air spaces within framing was found using ISO 100077-2

Detail 8.3.10

Interior Insulated Cross Laminated Timber (CLT) Spandrel at Window and Dowel Laminated Timber (DLT) – Intermediate Floor Intersection with Edge of Floor and Glulam Beam Not Aligned

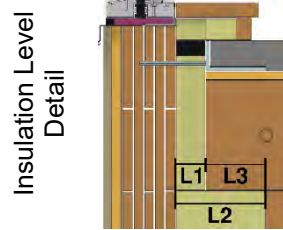
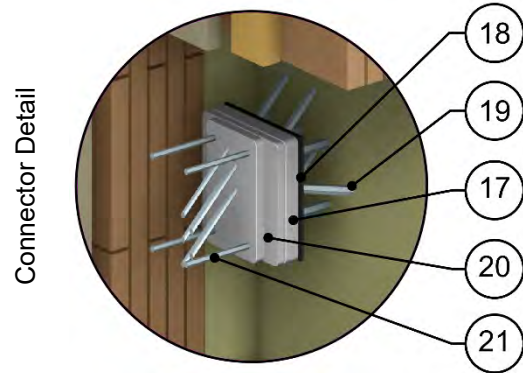
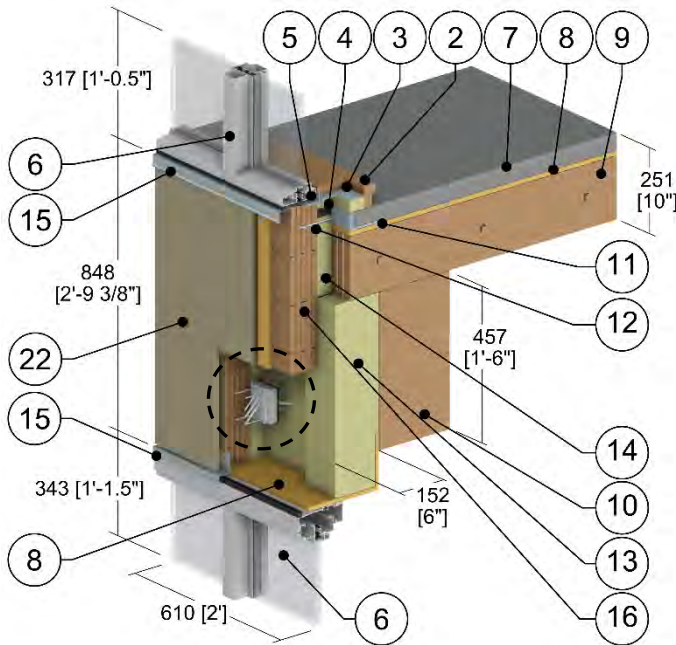

L1	L2	L3
in (mm)	in (mm)	in (mm)
2" (51)	6" (152)	4" (102)
3" (76)	6" (152)	3" (76)
4" (102)	6" (152)	2" (51)

ID	Component	Thickness Inches (mm)	Conductivity Btu-in / ft ² ·hr·°F (W/m K)	Nominal Resistance hr·ft ² ·°F/Btu (m ² K/W)	Density lb/ft ³ (kg/m ³)	Specific Heat Btu/lb·°F (J/kg K)
1	Interior Film ¹	-	-	R-0.6 to R-1.1 (0.11 RSI to 0.20 RSI)	-	-
2	Wood Sill	1" (25)	0.69 (0.10)	-	31 (500)	0.45 (1880)
3	Support Angle	18 Gauge	430 (62)	-	489 (7830)	0.12 (500)
4	Firestop Sealant	1" (25)	2.4 (0.35)	-	174 (2800)	0.17 (700)
5	Window Mounting Angle	1/8" (3)	1110 (160)	-	171 (2740)	0.21 (900)
6	Aluminum Window Wall Vision System ² : thermally broken frame, double glazed IGU U _{IGU} = 0.32 BTU/hr·ft ² ·°F (1.82 W/m ² K)					
7	Concrete Topping	2" (51)	12.5 (1.8)	-	140 (2250)	0.20 (850)
8	Plywood	5/8" (16)	0.69 (0.10)	-	31 (500)	0.45 (1880)
9	DLT Floor	7 1/4" (184)	0.83 (0.12)	-	31 (500)	0.45 (1880)
10	Glulam Beam	9.5" (241)	0.97 (0.14)	R-9.8 (1.73 RSI)	31 (500)	0.45 (1880)
11	L-angle	1/4" (6)	347 (50)	-	489 (7830)	0.12 (500)
12	Structural Screws 18" o.c.	ø 5/16" (8)	347 (50)	-	489 (7830)	0.12 (500)
13	Mineral Wool Insulation	6" (152)	0.24 (0.034)	R-25.2 (4.44 RSI)	4 (64)	0.20 (850)
14	Floor Mineral Wool Insulation	Varies	0.24 (0.034)	R-8.4 to R-16.8 (1.48 RSI to 2.96 RSI)	4 (64)	0.20 (850)
15	Aluminum Flashing	14 Gauge	1110 (160)	-	171 (2740)	0.21 (900)
16	CLT Panel	3.5" (89)	0.83 (0.12)	R-4.2 (0.79 RSI)	31 (500)	0.45 (1880)
17	ISO-CONNECT Plate	19/32" (15)	1110 (160)	-	171 (2740)	0.21 (900)
18	ISO-CONNECT Rubber Pad	1/8" (3)	1.7 (0.25)	-	-	-
19	ISO-CONNECT Fasteners x12	ø 5/16" (8)	347 (50)	-	489 (7830)	0.12 (500)
20	HVP Coupling Plates	19/32" (15)	1110 (160)	-	171 (2740)	0.21 (900)
21	HVP Fasteners x9	ø 3/16" (5)	347 (50)	-	489 (7830)	0.12 (500)
22	Fiber Cement Board Cladding with 3/4" (19mm) vented airspace incorporated into exterior heat transfer coefficient					
23	Exterior Film ¹	-	-	R-0.2 to R-0.7 (0.03 RSI to 0.12 RSI)	-	-

¹ Value selected from table 1, p. 26.1 of 2009 ASHRAE Handbook – Fundamentals depending on surface orientation

² The thermal conductivity of air spaces within framing was found using ISO 100077-2



Detail 8.3.11

Double Framed Wall with 2x6 and 2x4 Wood Studs (16" o.c.) and 2" Gap – Triple Glazed Flanged Fiberglass Window Intersection with Wood Blocking and Un-insulated Perimeter

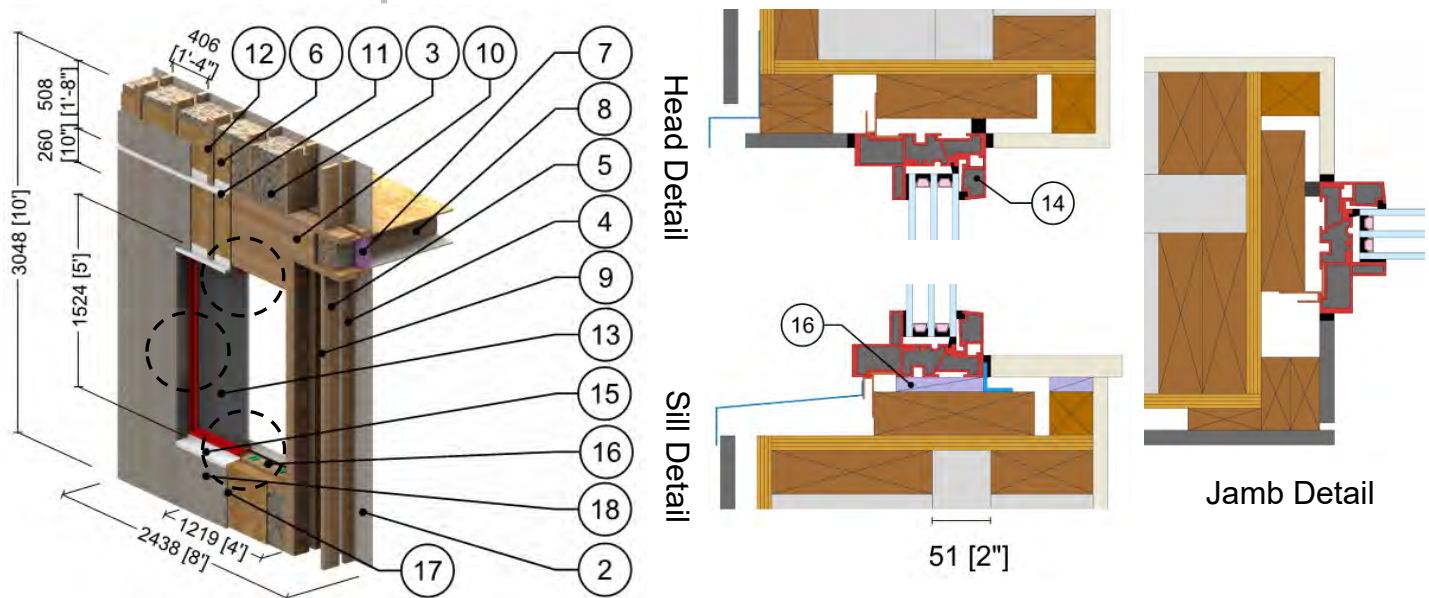

ID	Component	Thickness Inches (mm)	Conductivity Btu-in / ft ² ·hr·°F (W/m K)	Nominal Resistance hr·ft ² ·°F/Btu (m ² K/W)	Density lb/ft ³ (kg/m ³)	Specific Heat Btu/lb·°F (J/kg K)
1	Interior Film ¹	-	-	R-0.6 to R-1.1 (0.11 RSI to 0.20 RSI)	-	-
2	Gypsum Board	1/2" (13)	1.1 (0.16)	R-0.5 (0.08 RSI)	50 (800)	0.26 (1090)
3	Fill Insulation	11" (279)	Varies	R-38.5 to R-66.0 (6.78 RSI to 11.62 RSI)	-	-
4	2x4 Wood Stud (16" o.c.)	3 1/2" (89)	0.69 (0.10)	-	31 (500)	0.45 (1880)
5	2x6 Wood Stud (16" o.c.)	5 1/2" (140)	0.69 (0.10)	-	31 (500)	0.45 (1880)
6	Exterior Plywood Sheathing	1/2" (13)	0.69 (0.10)	R-0.7 (0.13 RSI)	31 (500)	0.45 (1880)
7	XPS Insulation	2" (51)	0.20 (0.029)	R-10 (1.76 RSI)	1.8 (28)	0.29 (1220)
8	2x10 Wood Joists (16" o.c.)	9 1/4" (235)	0.69 (0.10)	-	31 (500)	0.45 (1880)
9	Fasteners (6" o.c.)	0.43" (11) Ø	347 (50)	-	489 (7830)	0.12 (500)
10	2x10 Rim Joist	1 1/2" (38)	0.69 (0.10)	-	31 (500)	0.45 (1880)
11	Steel Flashing	18 Gauge	430 (62)	-	489 (7830)	0.12 (500)
12	Wood Strapping (1" x 3")	3/4" (19)	0.69 (0.10)	-	31 (500)	0.45 (1880)
13	5' (1.5m) x 4' (1.2m) Fiberglass window: triple glazed ² , IGU U _{IGU} = 0.156 BTU/hr.ft ² ·°F (0.888 W/m ² K)					
14	Frame Insulation	-	0.16 (0.023)	-	-	-
15	Aluminum Flashing	14 Gauge	1110 (160)	-	171 (2739)	0.21 (900)
16	Shims	-	1.7 (0.25)	-	-	-
17	Rainscreen Cavity	3/4" (19)	-	R-0.4 (0.07 RSI)	0.075 (1.2)	0.24 (1000)
18	Fiber Cement Board	1/2" (13)	4.86 (0.7)	-	-	-
19	Exterior Film ¹	-	-	R-0.2 (0.03 RSI)	-	-

¹ Value selected from table 1, p. 26.1 of 2009 ASHRAE Handbook – Fundamentals depending on surface orientation

² The thermal conductivity of air spaces within framing was found using ISO 100077-2

Detail 8.3.12

Double Framed Wall with 2x6 and 2x4 Wood Studs (16" o.c.) and 3" Gap – Triple Glazed Flanged Fiberglass Window Intersection with Wood Blocking and Un-insulated Perimeter

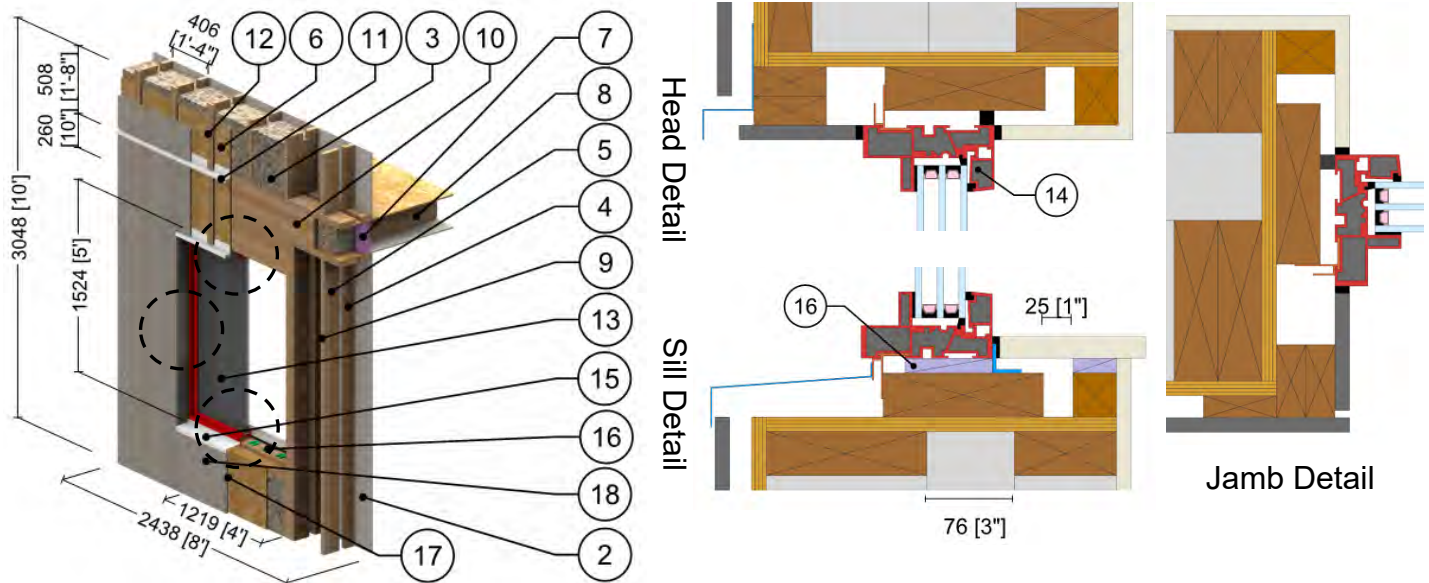

ID	Component	Thickness Inches (mm)	Conductivity Btu-in / ft ² ·hr·°F (W/m K)	Nominal Resistance hr·ft ² ·°F/Btu (m ² K/W)	Density lb/ft ³ (kg/m ³)	Specific Heat Btu/lb·°F (J/kg K)
1	Interior Film ¹	-	-	R-0.6 to R-1.1 (0.11 RSI to 0.20 RSI)	-	-
2	Gypsum Board	1/2" (13)	1.1 (0.16)	R-0.5 (0.08 RSI)	50 (800)	0.26 (1090)
3	Fill Insulation	12" (305)	Varies	R-42.0 to R-72.0 (7.40 RSI to 12.68 RSI)	-	-
4	2x4 Wood Stud (16" o.c.)	3 1/2" (89)	0.69 (0.10)	-	31 (500)	0.45 (1880)
5	2x6 Wood Stud (16" o.c.)	5 1/2" (140)	0.69 (0.10)	-	31 (500)	0.45 (1880)
6	Exterior Plywood Sheathing	1/2" (13)	0.69 (0.10)	R-0.7 (0.13 RSI)	31 (500)	0.45 (1880)
7	XPS Insulation	2" (51)	0.20 (0.029)	R-10 (1.76 RSI)	1.8 (28)	0.29 (1220)
8	2x10 Wood Joists (16" o.c.)	9 1/4" (235)	0.69 (0.10)	-	31 (500)	0.45 (1880)
9	Fasteners (6" o.c.)	0.43" (11) Ø	347 (50)	-	489 (7830)	0.12 (500)
10	2x10 Rim Joist	1 1/2" (38)	0.69 (0.10)	-	31 (500)	0.45 (1880)
11	Steel Flashing	18 Gauge	430 (62)	-	489 (7830)	0.12 (500)
12	Wood Strapping (1" x 3")	3/4" (19)	0.69 (0.10)	-	31 (500)	0.45 (1880)
13	5' (1.5m) x 4' (1.2m) Fiberglass window: triple glazed ² , IGU U _{IGU} = 0.156 BTU/hr.ft ² ·°F (0.888 W/m ² K)					
14	Frame Insulation	-	0.16 (0.023)	-	-	-
15	Aluminum Flashing	14 Gauge	1110 (160)	-	171 (2739)	0.21 (900)
16	Shims	-	1.7 (0.25)	-	-	-
17	Rainscreen Cavity	3/4" (19)	-	R-0.4 (0.07 RSI)	0.075 (1.2)	0.24 (1000)
18	Fiber Cement Board	1/2" (13)	4.86 (0.7)	-	-	-
19	Exterior Film ¹	-	-	R-0.2 (0.03 RSI)	-	-

¹ Value selected from table 1, p. 26.1 of 2009 ASHRAE Handbook – Fundamentals depending on surface orientation

² The thermal conductivity of air spaces within framing was found using ISO 100077-2

Detail 8.3.13

Double Framed Wall with 2x6 and 2x4 Wood Studs (16" o.c.) and 4" Gap – Triple Glazed Flanged Fiberglass Window Intersection with Wood Blocking and Un-insulated Perimeter

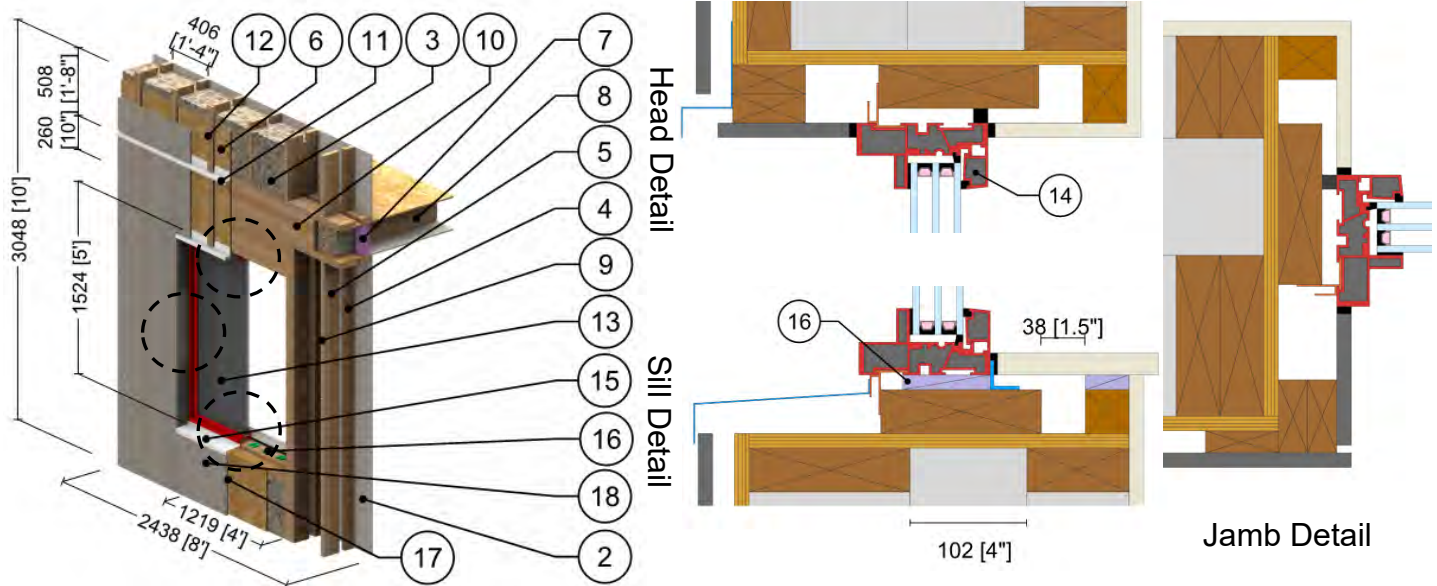

ID	Component	Thickness Inches (mm)	Conductivity Btu-in / ft ² ·hr·°F (W/m K)	Nominal Resistance hr·ft ² ·°F/Btu (m ² K/W)	Density lb/ft ³ (kg/m ³)	Specific Heat Btu/lb·°F (J/kg K)
1	Interior Film ¹	-	-	R-0.6 to R-1.1 (0.11 RSI to 0.20 RSI)	-	-
2	Gypsum Board	1/2" (13)	1.1 (0.16)	R-0.5 (0.08 RSI)	50 (800)	0.26 (1090)
3	Fill Insulation	13" (330)	Varies	R-45.5 to R-78.0 (8.01 RSI to 13.74 RSI)	-	-
4	2x4 Wood Stud (16" o.c.)	3 1/2" (89)	0.69 (0.10)	-	31 (500)	0.45 (1880)
5	2x6 Wood Stud (16" o.c.)	5 1/2" (140)	0.69 (0.10)	-	31 (500)	0.45 (1880)
6	Exterior Plywood Sheathing	1/2" (13)	0.69 (0.10)	R-0.7 (0.13 RSI)	31 (500)	0.45 (1880)
7	XPS Insulation	2" (51)	0.20 (0.029)	R-10 (1.76 RSI)	1.8 (28)	0.29 (1220)
8	2x10 Wood Joists (16" o.c.)	9 1/4" (235)	0.69 (0.10)	-	31 (500)	0.45 (1880)
9	Fasteners (6" o.c.)	0.43" (11) Ø	347 (50)	-	489 (7830)	0.12 (500)
10	2x10 Rim Joist	1 1/2" (38)	0.69 (0.10)	-	31 (500)	0.45 (1880)
11	Steel Flashing	18 Gauge	430 (62)	-	489 (7830)	0.12 (500)
12	Wood Strapping (1" x 3")	3/4" (19)	0.69 (0.10)	-	31 (500)	0.45 (1880)
13	5' (1.5m) x 4' (1.2m) Fiberglass window: triple glazed ² , IGU U _{IGU} = 0.156 BTU/hr.ft ² ·°F (0.888 W/m ² K)					
14	Frame Insulation	-	0.16 (0.023)	-	-	-
15	Aluminum Flashing	14 Gauge	1110 (160)	-	171 (2739)	0.21 (900)
16	Shims	-	1.7 (0.25)	-	-	-
17	Rainscreen Cavity	3/4" (19)	-	R-0.4 (0.07 RSI)	0.075 (1.2)	0.24 (1000)
18	Fiber Cement Board	1/2" (13)	4.86 (0.7)	-	-	-
19	Exterior Film ¹	-	-	R-0.2 (0.03 RSI)	-	-

¹ Value selected from table 1, p. 26.1 of 2009 ASHRAE Handbook – Fundamentals depending on surface orientation

² The thermal conductivity of air spaces within framing was found using ISO 100077-2

Detail 8.3.14

Double Framed Wall with 2x6 and 2x4 Wood Studs (16" o.c.) and 2" Gap – Triple Glazed Flanged Fiberglass Window Intersection with Wood Blocking and Insulated Perimeter

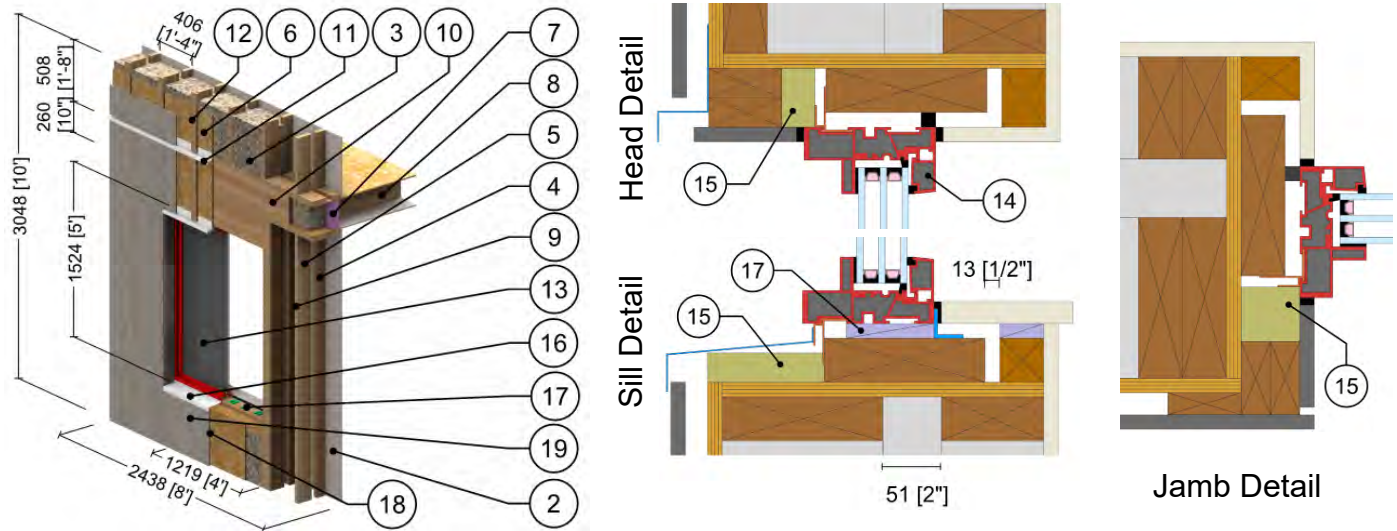

ID	Component	Thickness Inches (mm)	Conductivity Btu-in / ft ² -hr-°F (W/m K)	Nominal Resistance hr-ft ² -°F/Btu (m ² K/W)	Density lb/ft ³ (kg/m ³)	Specific Heat Btu/lb-°F (J/kg K)
1	Interior Film ¹	-	-	R-0.6 to R-1.1 (0.11 RSI to 0.20 RSI)	-	-
2	Gypsum Board	1/2" (13)	1.1 (0.16)	R-0.5 (0.08 RSI)	50 (800)	0.26 (1090)
3	Fill Insulation	11" (279)	Varies	R-38.5 to R-66.0 (6.78 RSI to 11.62 RSI)	-	-
4	2x4 Wood Stud (16" o.c.)	3 1/2" (89)	0.69 (0.10)	-	31 (500)	0.45 (1880)
5	2x6 Wood Stud (16" o.c.)	5 1/2" (140)	0.69 (0.10)	-	31 (500)	0.45 (1880)
6	Exterior Plywood Sheathing	1/2" (13)	0.69 (0.10)	R-0.7 (0.13 RSI)	31 (500)	0.45 (1880)
7	XPS Insulation	2" (51)	0.20 (0.029)	R-10 (1.76 RSI)	1.8 (28)	0.29 (1220)
8	2x10 Wood Joists (16" o.c.)	9 1/4" (235)	0.69 (0.10)	-	31 (500)	0.45 (1880)
9	Fasteners (6" o.c.)	0.43" (11) Ø	347 (50)	-	489 (7830)	0.12 (500)
10	2x10 Rim Joist	1 1/2" (38)	0.69 (0.10)	-	31 (500)	0.45 (1880)
11	Steel Flashing	18 Gauge	430 (62)	-	489 (7830)	0.12 (500)
12	Wood Strapping (1" x 3")	3/4" (19)	0.69 (0.10)	-	31 (500)	0.45 (1880)
13	5' (1.5m) x 4' (1.2m) Fiberglass window: triple glazed ² , IGU U _{IGU} = 0.156 BTU/hr.ft ² .°F (0.888 W/m ² K)					
14	Frame Insulation	-	0.16 (0.023)	-	-	-
15	Mineral Wool	-	0.24 (0.034)	-	4 (64)	0.20 (850)
16	Aluminum Flashing	14 Gauge	1110 (160)	-	171 (2739)	0.21 (900)
17	Shims	-	1.7 (0.25)	-	-	-
18	Rainscreen Cavity	3/4" (19)	-	R-0.4 (0.07 RSI)	0.075 (1.2)	0.24 (1000)
19	Fiber Cement Board	1/2" (13)	4.86 (0.7)	-	-	-
20	Exterior Film ¹	-	-	R-0.2 (0.03 RSI)	-	-

¹ Value selected from table 1, p. 26.1 of 2009 ASHRAE Handbook – Fundamentals depending on surface orientation

² The thermal conductivity of air spaces within framing was found using ISO 100077-2

Detail 8.3.15

Double Framed Wall with 2x6 and 2x4 Wood Studs (16" o.c.) and 3" Gap – Triple Glazed Flanged Fiberglass Window Intersection with Wood Blocking and Insulated Perimeter

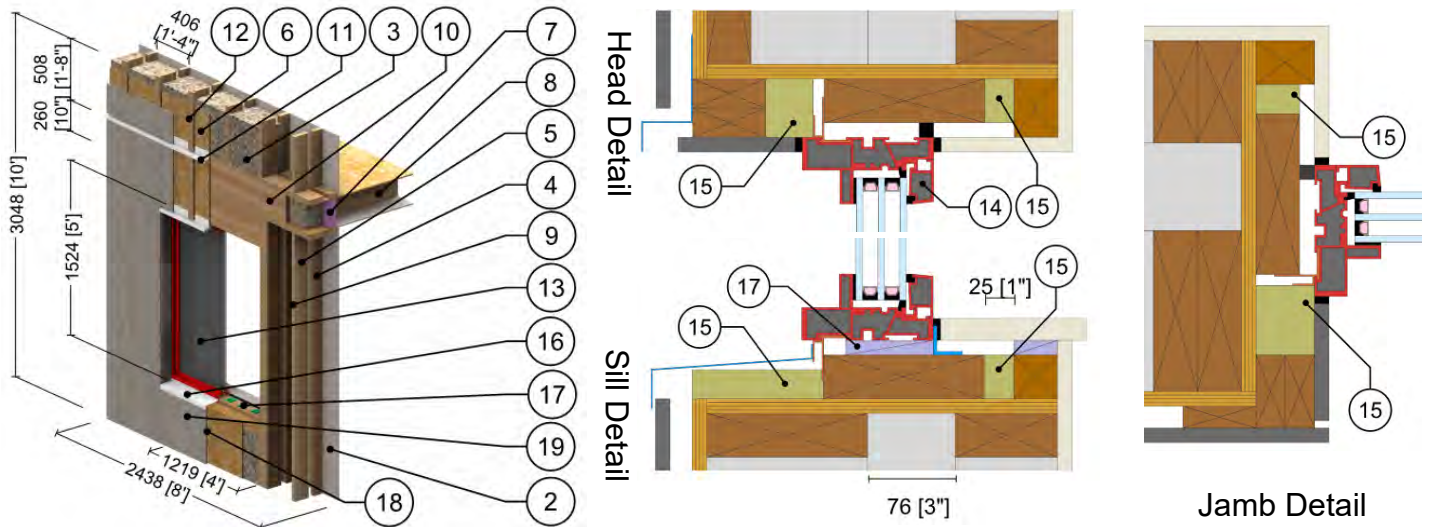

ID	Component	Thickness Inches (mm)	Conductivity Btu-in / ft ² ·hr·°F (W/m K)	Nominal Resistance hr·ft ² ·°F/Btu (m ² K/W)	Density lb/ft ³ (kg/m ³)	Specific Heat Btu/lb·°F (J/kg K)
1	Interior Film ¹	-	-	R-0.6 to R-1.1 (0.11 RSI to 0.20 RSI)	-	-
2	Gypsum Board	1/2" (13)	1.1 (0.16)	R-0.5 (0.08 RSI)	50 (800)	0.26 (1090)
3	Fill Insulation	12" (305)	Varies	R-42.0 to R-72.0 (7.40 RSI to 12.68 RSI)	-	-
4	2x4 Wood Stud (16" o.c.)	3 1/2" (89)	0.69 (0.10)	-	31 (500)	0.45 (1880)
5	2x6 Wood Stud (16" o.c.)	5 1/2" (140)	0.69 (0.10)	-	31 (500)	0.45 (1880)
6	Exterior Plywood Sheathing	1/2" (13)	0.69 (0.10)	R-0.7 (0.13 RSI)	31 (500)	0.45 (1880)
7	XPS Insulation	2" (51)	0.20 (0.029)	R-10 (1.76 RSI)	1.8 (28)	0.29 (1220)
8	2x10 Wood Joists (16" o.c.)	9 1/4" (235)	0.69 (0.10)	-	31 (500)	0.45 (1880)
9	Fasteners (6" o.c.)	0.43" (11) Ø	347 (50)	-	489 (7830)	0.12 (500)
10	2x10 Rim Joist	1 1/2" (38)	0.69 (0.10)	-	31 (500)	0.45 (1880)
11	Steel Flashing	18 Gauge	430 (62)	-	489 (7830)	0.12 (500)
12	Wood Strapping (1" x 3")	3/4" (19)	0.69 (0.10)	-	31 (500)	0.45 (1880)
13	5' (1.5m) x 4' (1.2m) Fiberglass window: triple glazed ² , IGU U _{IGU} = 0.156 BTU/hr.ft ² ·°F (0.888 W/m ² K)					
14	Frame Insulation	-	0.16 (0.023)	-	-	-
15	Mineral Wool	-	0.24 (0.034)	-	4 (64)	0.20 (850)
16	Aluminum Flashing	14 Gauge	1110 (160)	-	171 (2739)	0.21 (900)
17	Shims	-	1.7 (0.25)	-	-	-
18	Rainscreen Cavity	3/4" (19)	-	R-0.4 (0.07 RSI)	0.075 (1.2)	0.24 (1000)
19	Fiber Cement Board	1/2" (13)	4.86 (0.7)	-	-	-
20	Exterior Film ¹	-	-	R-0.2 (0.03 RSI)	-	-

¹ Value selected from table 1, p. 26.1 of 2009 ASHRAE Handbook – Fundamentals depending on surface orientation

² The thermal conductivity of air spaces within framing was found using ISO 100077-2

Detail 8.3.16

Double Framed Wall with 2x6 and 2x4 Wood Studs (16" o.c.) and 4" Gap – Triple Glazed Flanged Fiberglass Window Intersection with Wood Blocking and Insulated Perimeter

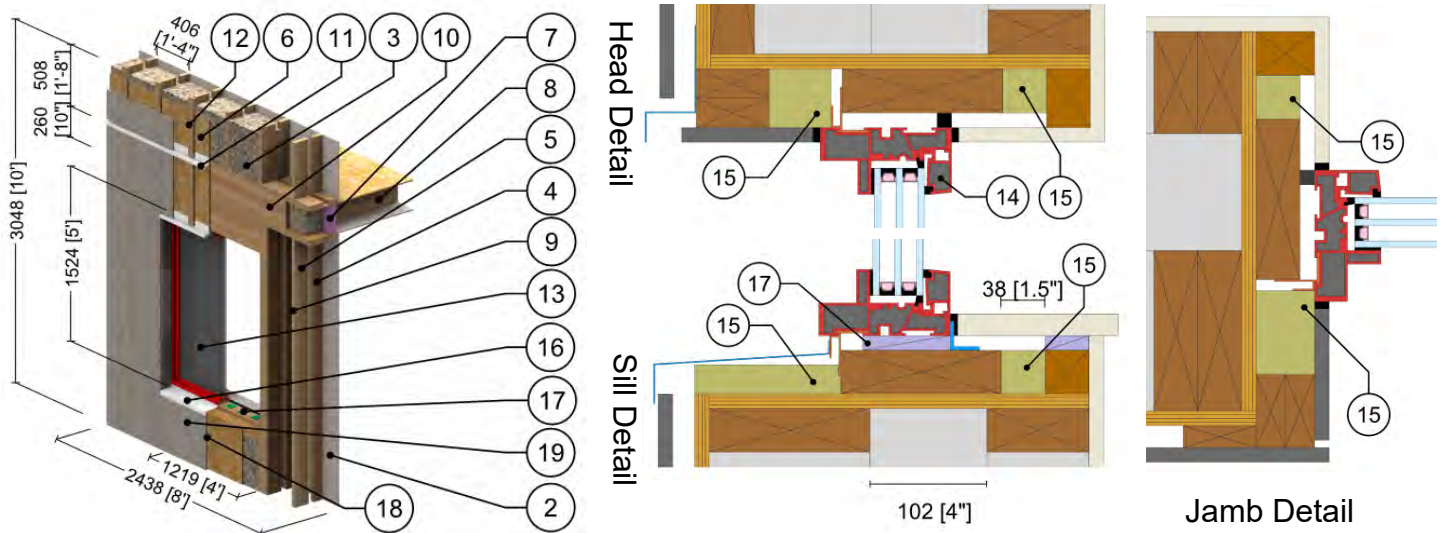

ID	Component	Thickness Inches (mm)	Conductivity Btu-in / ft ² ·hr·°F (W/m K)	Nominal Resistance hr·ft ² ·°F/Btu (m ² K/W)	Density lb/ft ³ (kg/m ³)	Specific Heat Btu/lb·°F (J/kg K)
1	Interior Film ¹	-	-	R-0.6 to R-1.1 (0.11 RSI to 0.20 RSI)	-	-
2	Gypsum Board	1/2" (13)	1.1 (0.16)	R-0.5 (0.08 RSI)	50 (800)	0.26 (1090)
3	Fill Insulation	13" (330)	Varies	R-45.5 to R-78.0 (8.01 RSI to 13.74 RSI)	-	-
4	2x4 Wood Stud (16" o.c.)	3 1/2" (89)	0.69 (0.10)	-	31 (500)	0.45 (1880)
5	2x6 Wood Stud (16" o.c.)	5 1/2" (140)	0.69 (0.10)	-	31 (500)	0.45 (1880)
6	Exterior Plywood Sheathing	1/2" (13)	0.69 (0.10)	R-0.7 (0.13 RSI)	31 (500)	0.45 (1880)
7	XPS Insulation	2" (51)	0.20 (0.029)	R-10 (1.76 RSI)	1.8 (28)	0.29 (1220)
8	2x10 Wood Joists (16" o.c.)	9 1/4" (235)	0.69 (0.10)	-	31 (500)	0.45 (1880)
9	Fasteners (6" o.c.)	0.43" (11) Ø	347 (50)	-	489 (7830)	0.12 (500)
10	2x10 Rim Joist	1 1/2" (38)	0.69 (0.10)	-	31 (500)	0.45 (1880)
11	Steel Flashing	18 Gauge	430 (62)	-	489 (7830)	0.12 (500)
12	Wood Strapping (1" x 3")	3/4" (19)	0.69 (0.10)	-	31 (500)	0.45 (1880)
13	5' (1.5m) x 4' (1.2m) Fiberglass window: triple glazed ² , IGU U _{IGU} = 0.156 BTU/hr.ft ² ·°F (0.888 W/m ² K)					
14	Frame Insulation	-	0.16 (0.023)	-	-	-
15	Mineral Wool	-	0.24 (0.034)	-	4 (64)	0.20 (850)
16	Aluminum Flashing	14 Gauge	1110 (160)	-	171 (2739)	0.21 (900)
17	Shims	-	1.7 (0.25)	-	-	-
18	Rainscreen Cavity	3/4" (19)	-	R-0.4 (0.07 RSI)	0.075 (1.2)	0.24 (1000)
19	Fiber Cement Board	1/2" (13)	4.86 (0.7)	-	-	-
20	Exterior Film ¹	-	-	R-0.2 (0.03 RSI)	-	-

¹ Value selected from table 1, p. 26.1 of 2009 ASHRAE Handbook – Fundamentals depending on surface orientation

² The thermal conductivity of air spaces within framing was found using ISO 100077-2

Detail 8.3.17

Double Framed Wall with 2x6 and 2x4 Wood Studs (16" o.c.) Wall and 2" Gap – Triple Glazed Rebated Fiberglass Window Intersection and Un-Insulated Perimeter

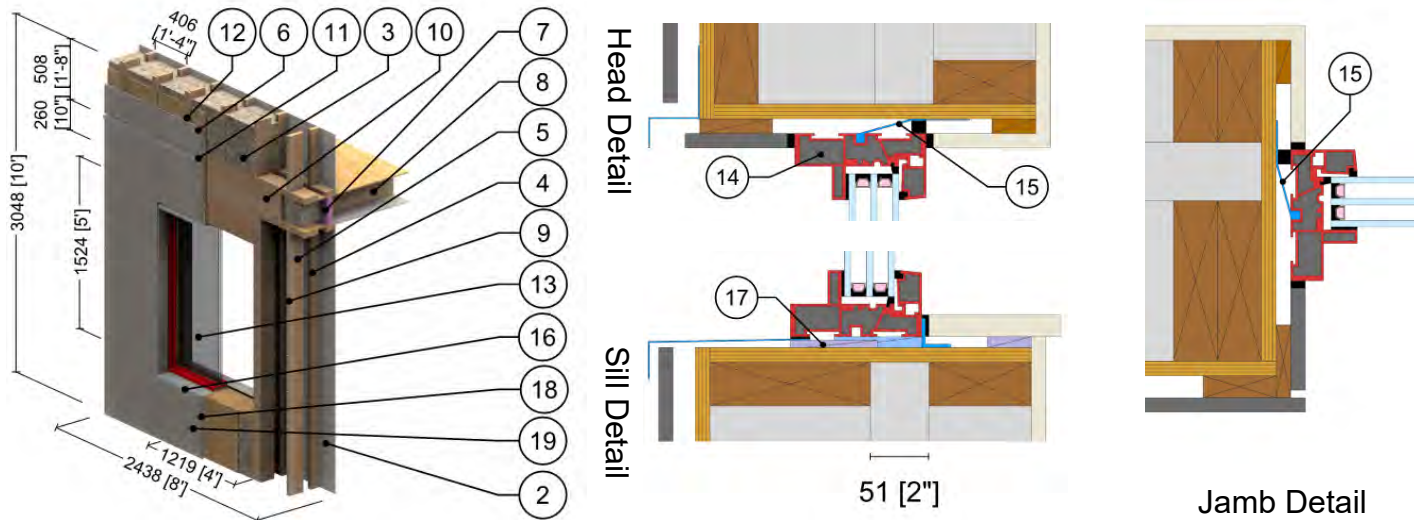

ID	Component	Thickness Inches (mm)	Conductivity Btu·in / ft ² ·hr·°F (W/m K)	Nominal Resistance hr·ft ² ·°F/Btu (m ² K/W)	Density lb/ft ³ (kg/m ³)	Specific Heat Btu/lb·°F (J/kg K)
1	Interior Film ¹	-	-	R-0.6 to R-1.1 (0.11 to 0.2 RSI)	-	-
2	Gypsum Board	1/2" (13)	1.1 (0.16)	R-0.5 (0.08 RSI)	50 (800)	0.26 (1090)
3	Fill Insulation	11" (279)	Varies	R-38.5 to R-66.0 (6.78 RSI to 11.62 RSI)	-	-
4	2x4 Wood Stud (16" o.c.)	3 1/2" (89)	0.69 (0.10)	-	31 (500)	0.45 (1880)
5	2x6 Wood Stud (16" o.c.)	5 1/2" (140)	0.69 (0.10)	-	31 (500)	0.45 (1880)
6	Exterior Wood Sheathing	1/2" (13)	0.69 (0.10)	R-0.7 (0.13 RSI)	31 (500)	0.45 (1880)
7	XPS Insulation	2" (51)	0.20 (0.029)	R-10 (1.76 RSI)	1.8 (28)	0.29 (1220)
8	2x10 Wood Joists (16" o.c.)	9 1/4" (235)	0.69 (0.10)	-	31 (500)	0.45 (1880)
9	Fasteners (6" o.c.)	0.43" (11) Ø	347 (50)	-	489 (7830)	0.12 (500)
10	2x10 Rim Joist	1 1/2" (38)	0.69 (0.10)	-	31 (500)	0.45 (1880)
11	Steel Flashing	18 Gauge	430 (62)	-	489 (7830)	0.12 (500)
12	1x3 Wood Strapping	3/4" (19)	0.69 (0.10)	-	31 (500)	0.45 (1880)
13	5' (1.5m) x 4' (1.2m) Fiberglass window: triple glazed ² , IGU U _{IGU} = 0.156 BTU/hr.ft ² .°F (0.89 W/m ² K)					
14	Window Frame Insulation	-	0.16 (0.023)	-	-	-
15	Strap Anchor	-	430 (62)	-	489 (7830)	0.12 (500)
16	Aluminum Flashing	14 Gauge	1110 (160)	-	171 (2739)	0.21 (900)
17	Shims	-	1.7 (0.25)	-	-	-
18	Rainscreen Cavity	3/4" (19)	-	R-0.4 (0.07 RSI)	0.075 (1.2)	0.24 (1000)
19	Fiber Cement	1/2" (13)	4.86 (0.7)	-	-	-
20	Exterior Film ¹	-	-	R-0.2 (0.03 RSI)	-	-

¹ Value selected from table 1, p. 26.1 of 2009 ASHRAE Handbook – Fundamentals depending on surface orientation

² The thermal conductivity of air spaces within framing was found using ISO 100077-2

Detail 8.3.18

Double Framed Wall with 2x6 and 2x4 Wood Studs (16" o.c.) Wall and 3" Gap – Triple Glazed Rebated Fiberglass Window Intersection and Un-Insulated Perimeter

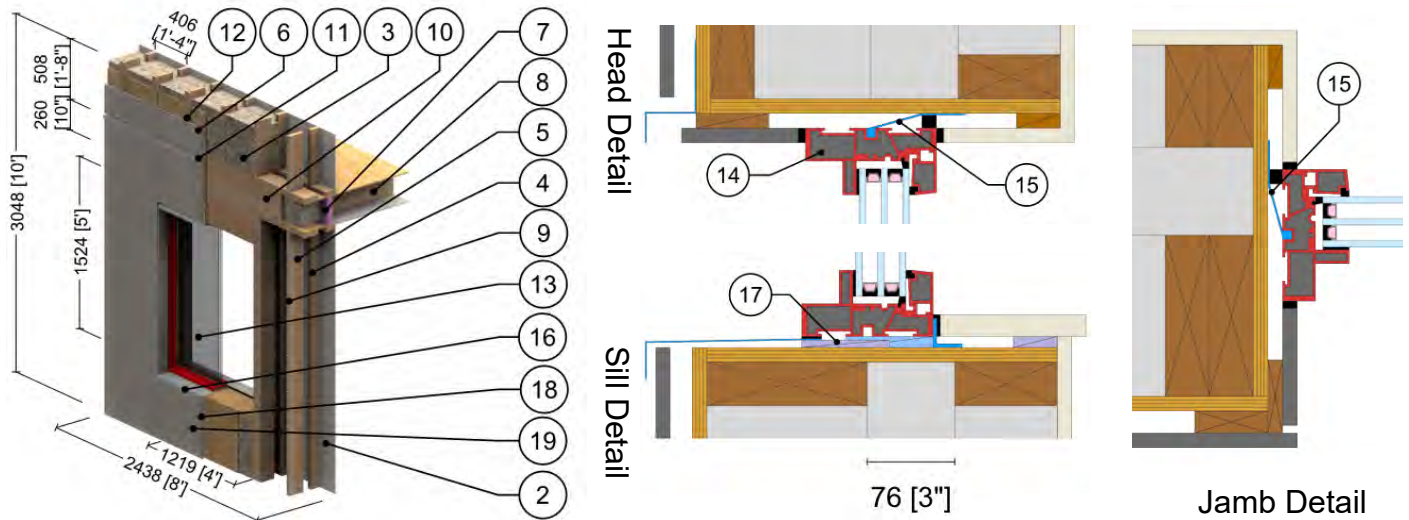

ID	Component	Thickness Inches (mm)	Conductivity Btu-in / ft ² -hr-°F (W/m K)	Nominal Resistance hr-ft ² -°F/Btu (m ² K/W)	Density lb/ft ³ (kg/m ³)	Specific Heat Btu/lb-°F (J/kg K)
1	Interior Film ¹	-	-	R-0.6 to R-1.1 (0.11 to 0.2 RSI)	-	-
2	Gypsum Board	1/2" (13)	1.1 (0.16)	R-0.5 (0.08 RSI)	50 (800)	0.26 (1090)
3	Fill Insulation	12" (305)	Varies	R-42.0 to R-72.0 (7.40 RSI to 12.68 RSI)	-	-
4	2x4 Wood Stud (16" o.c.)	3 1/2" (89)	0.69 (0.10)	-	31 (500)	0.45 (1880)
5	2x6 Wood Stud (16" o.c.)	5 1/2" (140)	0.69 (0.10)	-	31 (500)	0.45 (1880)
6	Exterior Wood Sheathing	1/2" (13)	0.69 (0.10)	R-0.7 (0.13 RSI)	31 (500)	0.45 (1880)
7	XPS Insulation	2" (51)	0.20 (0.029)	R-10 (1.76 RSI)	1.8 (28)	0.29 (1220)
8	2x10 Wood Joists (16" o.c.)	9 1/4" (235)	0.69 (0.10)	-	31 (500)	0.45 (1880)
9	Fasteners (6" o.c.)	0.43" (11) Ø	347 (50)	-	489 (7830)	0.12 (500)
10	2x10 Rim Joist	1 1/2" (38)	0.69 (0.10)	-	31 (500)	0.45 (1880)
11	Steel Flashing	18 Gauge	430 (62)	-	489 (7830)	0.12 (500)
12	1x3 Wood Strapping	3/4" (19)	0.69 (0.10)	-	31 (500)	0.45 (1880)
13	5' (1.5m) x 4' (1.2m) Fiberglass window: triple glazed ² , IGU U _{IGU} = 0.156 BTU/hr.ft ² .°F (0.89 W/m ² K)					
14	Window Frame Insulation	-	0.16 (0.023)	-	-	-
15	Strap Anchor	-	430 (62)	-	489 (7830)	0.12 (500)
16	Aluminum Flashing	14 Gauge	1110 (160)	-	171 (2739)	0.21 (900)
17	Shims	-	1.7 (0.25)	-	-	-
18	Rainscreen Cavity	3/4" (19)	-	R-0.4 (0.07 RSI)	0.075 (1.2)	0.24 (1000)
19	Fiber Cement	1/2" (13)	4.86 (0.7)	-	-	-
20	Exterior Film ¹	-	-	R-0.2 (0.03 RSI)	-	-

¹ Value selected from table 1, p. 26.1 of 2009 ASHRAE Handbook – Fundamentals depending on surface orientation

² The thermal conductivity of air spaces within framing was found using ISO 100077-2

Detail 8.3.19

Double Framed Wall with 2x6 and 2x4 Wood Studs (16" o.c.) Wall and 4" Gap – Triple Glazed Rebated Fiberglass Window Intersection and Un-Insulated Perimeter

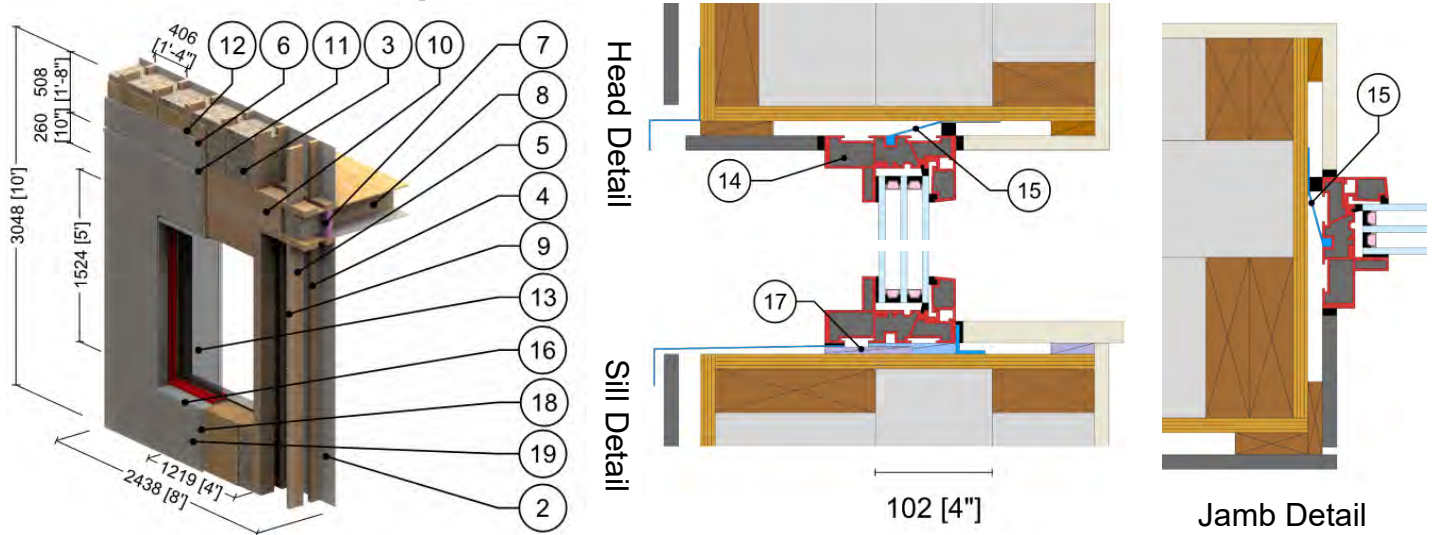

ID	Component	Thickness Inches (mm)	Conductivity Btu·in / ft ² ·hr·°F (W/m K)	Nominal Resistance hr·ft ² ·°F/Btu (m ² K/W)	Density lb/ft ³ (kg/m ³)	Specific Heat Btu/lb·°F (J/kg K)
1	Interior Film ¹	-	-	R-0.6 to R-1.1 (0.11 to 0.2 RSI)	-	-
2	Gypsum Board	1/2" (13)	1.1 (0.16)	R-0.5 (0.08 RSI)	50 (800)	0.26 (1090)
3	Fill Insulation	13" (330)	Varies	R-45.5 to R-78.0 (8.01 RSI to 13.74 RSI)	-	-
4	2x4 Wood Stud (16" o.c.)	3 1/2" (89)	0.69 (0.10)	-	31 (500)	0.45 (1880)
5	2x6 Wood Stud (16" o.c.)	5 1/2" (140)	0.69 (0.10)	-	31 (500)	0.45 (1880)
6	Exterior Wood Sheathing	1/2" (13)	0.69 (0.10)	R-0.7 (0.13 RSI)	31 (500)	0.45 (1880)
7	XPS Insulation	2" (51)	0.20 (0.029)	R-10 (1.76 RSI)	1.8 (28)	0.29 (1220)
8	2x10 Wood Joists (16" o.c.)	9 1/4" (235)	0.69 (0.10)	-	31 (500)	0.45 (1880)
9	Fasteners (6" o.c.)	0.43" (11) Ø	347 (50)	-	489 (7830)	0.12 (500)
10	2x10 Rim Joist	1 1/2" (38)	0.69 (0.10)	-	31 (500)	0.45 (1880)
11	Steel Flashing	18 Gauge	430 (62)	-	489 (7830)	0.12 (500)
12	1x3 Wood Strapping	3/4" (19)	0.69 (0.10)	-	31 (500)	0.45 (1880)
13	5' (1.5m) x 4' (1.2m) Fiberglass window: triple glazed ² , IGU U _{IGU} = 0.156 BTU/hr.ft ² .°F (0.89 W/m ² K)					
14	Window Frame Insulation	-	0.16 (0.023)	-	-	-
15	Strap Anchor	-	430 (62)	-	489 (7830)	0.12 (500)
16	Aluminum Flashing	14 Gauge	1110 (160)	-	171 (2739)	0.21 (900)
17	Shims	-	1.7 (0.25)	-	-	-
18	Rainscreen Cavity	3/4" (19)	-	R-0.4 (0.07 RSI)	0.075 (1.2)	0.24 (1000)
19	Fiber Cement	1/2" (13)	4.86 (0.7)	-	-	-
20	Exterior Film ¹	-	-	R-0.2 (0.03 RSI)	-	-

¹ Value selected from table 1, p. 26.1 of 2009 ASHRAE Handbook – Fundamentals depending on surface orientation

² The thermal conductivity of air spaces within framing was found using ISO 100077-2

Detail 8.3.20

Double Framed Wall with 2x6 and 2x4 Wood Studs (16" o.c.) Wall and 2" Gap – Triple Glazed Rebated Fiberglass Window Intersection with Insulation at Window Perimeter

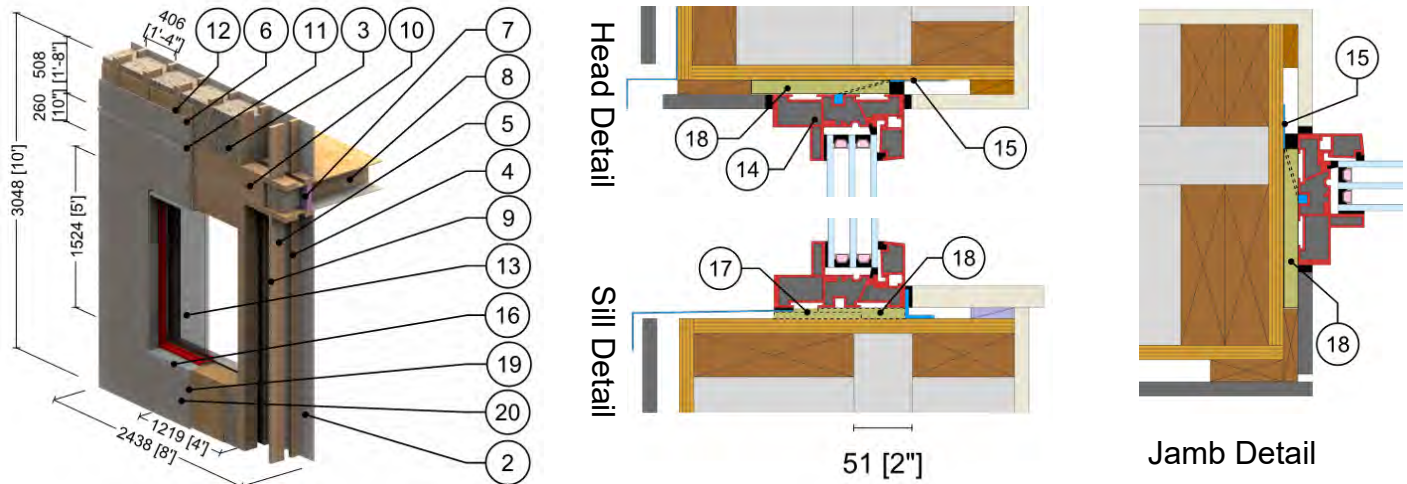

ID	Component	Thickness Inches (mm)	Conductivity Btu-in / ft ² ·hr·°F (W/m K)	Nominal Resistance hr·ft ² ·°F/Btu (m ² K/W)	Density lb/ft ³ (kg/m ³)	Specific Heat Btu/lb·°F (J/kg K)
1	Interior Film ¹	-	-	R-0.6 to R-1.1 (0.11 to 0.2 RSI)	-	-
2	Gypsum Board	1/2" (13)	1.1 (0.16)	R-0.5 (0.08 RSI)	50 (800)	0.26 (1090)
3	Fill Insulation	11" (279)	Varies	R-38.5 to R-66.0 (6.78 RSI to 11.62 RSI)	-	-
4	2x4 Wood Stud (16" o.c.)	3 1/2" (89)	0.69 (0.10)	-	31 (500)	0.45 (1880)
5	2x6 Wood Stud (16" o.c.)	5 1/2" (140)	0.69 (0.10)	-	31 (500)	0.45 (1880)
6	Exterior Wood Sheathing	1/2" (13)	0.69 (0.10)	R-0.7 (0.13 RSI)	31 (500)	0.45 (1880)
7	XPS Insulation	2" (51)	0.20 (0.029)	R-10 (1.76 RSI)	1.8 (28)	0.29 (1220)
8	2x10 Wood Joists (16" o.c.)	9 1/4" (235)	0.69 (0.10)	-	31 (500)	0.45 (1880)
9	Fasteners (6" o.c.)	0.43" (11) Ø	347 (50)	-	489 (7830)	0.12 (500)
10	2x10 Rim Joist	1 1/2" (38)	0.69 (0.10)	-	31 (500)	0.45 (1880)
11	Steel Flashing	18 Gauge	430 (62)	-	489 (7830)	0.12 (500)
12	1x3 Wood Strapping	3/4" (19)	0.69 (0.10)	-	31 (500)	0.45 (1880)
13	5' (1.5m) x 4' (1.2m) Fiberglass window: triple glazed ² , IGU U _{IGU} = 0.156 BTU/hr.ft ² .°F (0.89 W/m ² K)					
14	Frame Insulation	-	0.16 (0.023)	-	-	-
15	Strap Anchor	-	430 (62)	-	489 (7830)	0.12 (500)
16	Aluminum Flashing	14 Gauge	1110 (160)	-	171 (2739)	0.21 (900)
17	Shims	-	1.7 (0.25)	-	-	-
18	Compressed Mineral Wool	1/2" (13)	0.22 (0.032)	R-2.2 (0.39 RSI)	-	-
19	Rainscreen Cavity	3/4" (19)	-	R-0.4 (0.07 RSI)	0.075 (1.2)	0.24 (1000)
20	Fiber Cement	1/2" (13)	4.86 (0.7)	-	-	-
21	Exterior Film ¹	-	-	R-0.2 (0.03 RSI)	-	-

¹ Value selected from table 1, p. 26.1 of 2009 ASHRAE Handbook – Fundamentals depending on surface orientation

² The thermal conductivity of air spaces within framing was found using ISO 100077-2

Detail 8.3.21

Double Framed Wall with 2x6 and 2x4 Wood Studs (16" o.c.) Wall and 3" Gap – Triple Glazed Rebated Fiberglass Window Intersection with Insulation at Window Perimeter

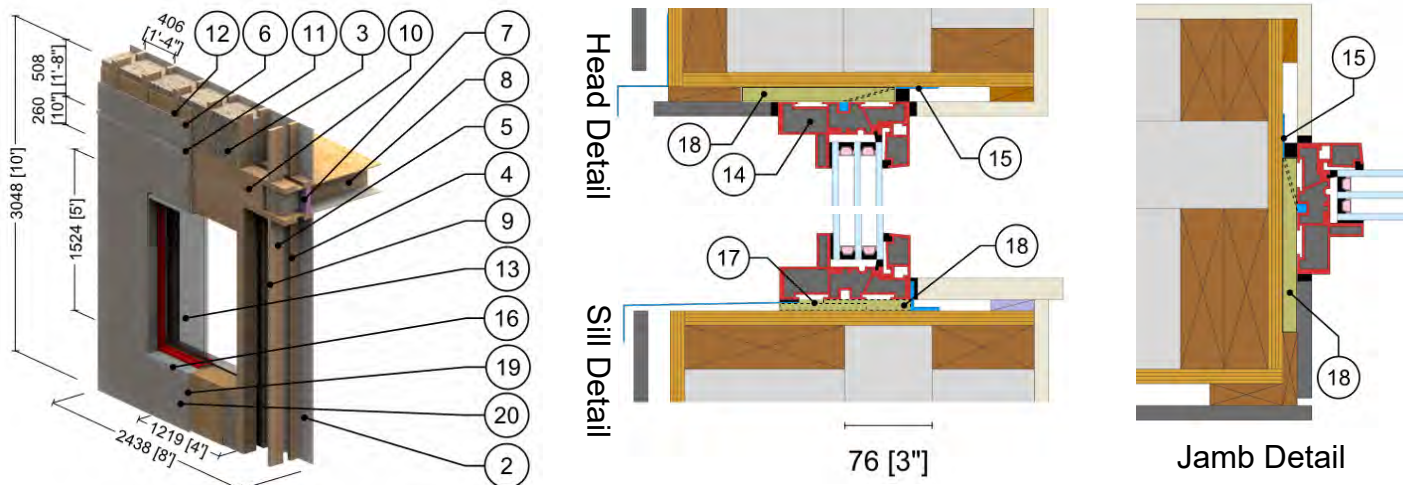

ID	Component	Thickness Inches (mm)	Conductivity Btu-in / ft ² ·hr·°F (W/m K)	Nominal Resistance hr·ft ² ·°F/Btu (m ² K/W)	Density lb/ft ³ (kg/m ³)	Specific Heat Btu/lb·°F (J/kg K)
1	Interior Film ¹	-	-	R-0.6 to R-1.1 (0.11 to 0.2 RSI)	-	-
2	Gypsum Board	1/2" (13)	1.1 (0.16)	R-0.5 (0.08 RSI)	50 (800)	0.26 (1090)
3	Fill Insulation	12" (305)	Varies	R-42.0 to R-72.0 (7.40 RSI to 12.68 RSI)	-	-
4	2x4 Wood Stud (16" o.c.)	3 1/2" (89)	0.69 (0.10)	-	31 (500)	0.45 (1880)
5	2x6 Wood Stud (16" o.c.)	5 1/2" (140)	0.69 (0.10)	-	31 (500)	0.45 (1880)
6	Exterior Wood Sheathing	1/2" (13)	0.69 (0.10)	R-0.7 (0.13 RSI)	31 (500)	0.45 (1880)
7	XPS Insulation	2" (51)	0.20 (0.029)	R-10 (1.76 RSI)	1.8 (28)	0.29 (1220)
8	2x10 Wood Joists (16" o.c.)	9 1/4" (235)	0.69 (0.10)	-	31 (500)	0.45 (1880)
9	Fasteners (6" o.c.)	0.43" (11) Ø	347 (50)	-	489 (7830)	0.12 (500)
10	2x10 Rim Joist	1 1/2" (38)	0.69 (0.10)	-	31 (500)	0.45 (1880)
11	Steel Flashing	18 Gauge	430 (62)	-	489 (7830)	0.12 (500)
12	1x3 Wood Strapping	3/4" (19)	0.69 (0.10)	-	31 (500)	0.45 (1880)
13	5' (1.5m) x 4' (1.2m) Fiberglass window: triple glazed ² , IGU U _{IGU} = 0.156 BTU/hr.ft ² .°F (0.89 W/m ² K)					
14	Frame Insulation	-	0.16 (0.023)	-	-	-
15	Strap Anchor	-	430 (62)	-	489 (7830)	0.12 (500)
16	Aluminum Flashing	14 Gauge	1110 (160)	-	171 (2739)	0.21 (900)
17	Shims	-	1.7 (0.25)	-	-	-
18	Compressed Mineral Wool	1/2" (13)	0.22 (0.032)	R-2.2 (0.39 RSI)	-	-
19	Rainscreen Cavity	3/4" (19)	-	R-0.4 (0.07 RSI)	0.075 (1.2)	0.24 (1000)
20	Fiber Cement	1/2" (13)	4.86 (0.7)	-	-	-
21	Exterior Film ¹	-	-	R-0.2 (0.03 RSI)	-	-

¹ Value selected from table 1, p. 26.1 of 2009 ASHRAE Handbook – Fundamentals depending on surface orientation

² The thermal conductivity of air spaces within framing was found using ISO 100077-2

Detail 8.3.22

Double Framed Wall with 2x6 and 2x4 Wood Studs (16" o.c.) Wall and 4" Gap – Triple Glazed Rebated Fiberglass Window Intersection with Insulation at Window Perimeter

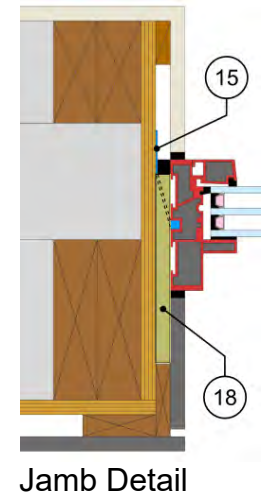
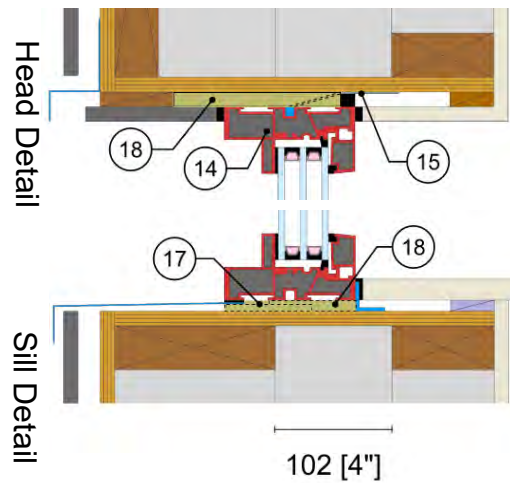
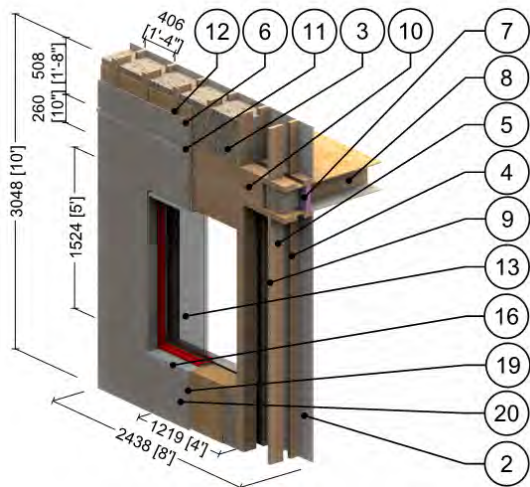

ID	Component	Thickness Inches (mm)	Conductivity Btu-in / ft ² -hr-°F (W/m K)	Nominal Resistance hr-ft ² -°F/Btu (m ² K/W)	Density lb/ft ³ (kg/m ³)	Specific Heat Btu/lb-°F (J/kg K)
1	Interior Film ¹	-	-	R-0.6 to R-1.1 (0.11 to 0.2 RSI)	-	-
2	Gypsum Board	1/2" (13)	1.1 (0.16)	R-0.5 (0.08 RSI)	50 (800)	0.26 (1090)
3	Fill Insulation	13" (330)	Varies	R-45.5 to R-78.0 (8.01 RSI to 13.74 RSI)	-	-
4	2x4 Wood Stud (16" o.c.)	3 1/2" (89)	0.69 (0.10)	-	31 (500)	0.45 (1880)
5	2x6 Wood Stud (16" o.c.)	5 1/2" (140)	0.69 (0.10)	-	31 (500)	0.45 (1880)
6	Exterior Wood Sheathing	1/2" (13)	0.69 (0.10)	R-0.7 (0.13 RSI)	31 (500)	0.45 (1880)
7	XPS Insulation	2" (51)	0.20 (0.029)	R-10 (1.76 RSI)	1.8 (28)	0.29 (1220)
8	2x10 Wood Joists (16" o.c.)	9 1/4" (235)	0.69 (0.10)	-	31 (500)	0.45 (1880)
9	Fasteners (6" o.c.)	0.43" (11) Ø	347 (50)	-	489 (7830)	0.12 (500)
10	2x10 Rim Joist	1 1/2" (38)	0.69 (0.10)	-	31 (500)	0.45 (1880)
11	Steel Flashing	18 Gauge	430 (62)	-	489 (7830)	0.12 (500)
12	1x3 Wood Strapping	3/4" (19)	0.69 (0.10)	-	31 (500)	0.45 (1880)
13	5' (1.5m) x 4' (1.2m) Fiberglass window: triple glazed ² , IGU U _{IGU} = 0.156 BTU/hr.ft ² .°F (0.89 W/m ² K)					
14	Frame Insulation	-	0.16 (0.023)	-	-	-
15	Strap Anchor	-	430 (62)	-	489 (7830)	0.12 (500)
16	Aluminum Flashing	14 Gauge	1110 (160)	-	171 (2739)	0.21 (900)
17	Shims	-	1.7 (0.25)	-	-	-
18	Compressed Mineral Wool	1/2" (13)	0.22 (0.032)	R-2.2 (0.39 RSI)	-	-
19	Rainscreen Cavity	3/4" (19)	-	R-0.4 (0.07 RSI)	0.075 (1.2)	0.24 (1000)
20	Fiber Cement	1/2" (13)	4.86 (0.7)	-	-	-
21	Exterior Film ¹	-	-	R-0.2 (0.03 RSI)	-	-

¹ Value selected from table 1, p. 26.1 of 2009 ASHRAE Handbook – Fundamentals depending on surface orientation

² The thermal conductivity of air spaces within framing was found using ISO 100077-2

Detail 8.3.23

Exterior and Interior Insulated 2x6 Wood Stud (16" o.c.) Wall Assembly with Wood Strapping and Continuous Insulation Supporting Rainscreen Fiber Cement Board – Double Glazed Aluminum Window Intersection Aligned with Exterior Insulation

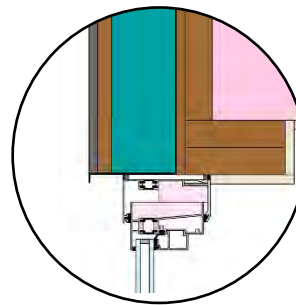
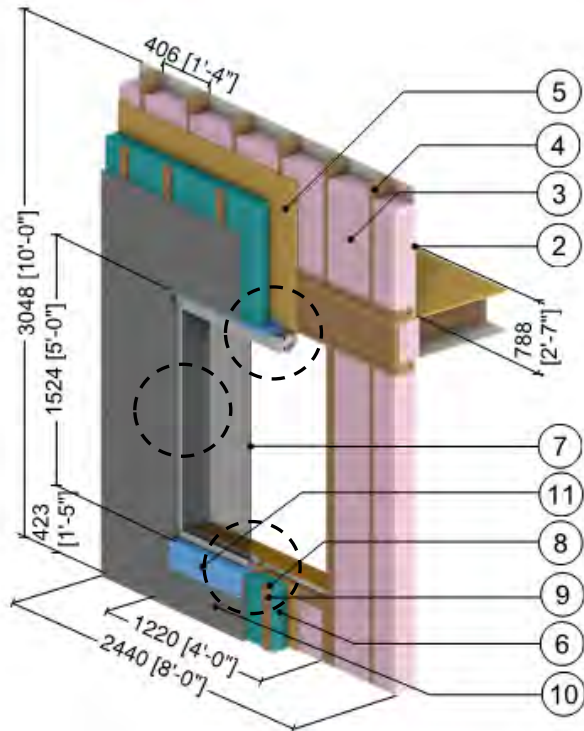

Head Detail

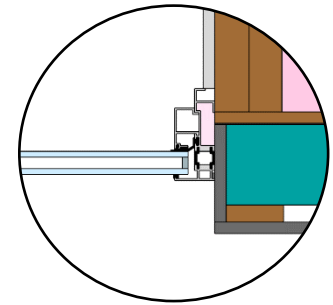

Jamb Detail

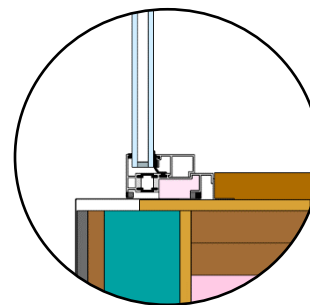

Sill Detail

ID	Component	Thickness Inches (mm)	Conductivity Btu·in / ft ² ·hr·°F (W/m K)	Nominal Resistance hr·ft ² ·°F/Btu (m ² K/W)	Density lb/ft ³ (kg/m ³)	Specific Heat Btu/lb·°F (J/kg K)
1	Interior Film ¹	-	-	R-0.6 to R-0.9 (0.11 RSI to 0.16 RSI)	-	-
2	Gypsum Board	1/2" (13)	1.1 (0.16)	R-0.5 (0.08 RSI)	50 (800)	0.26 (1090)
3	Fiberglass Batt Insulation	5 1/2" (140)	-	R-19 (3.3 RSI)	0.9 (14)	0.17 (710)
4	2x6 Wood Stud (16" o.c.)	5 1/2" (140)	0.69 (0.10)	-	31 (500)	0.45 (1880)
5	Exterior Wood Sheathing	1/2" (13)	0.69 (0.10)	R-0.7 (0.12 RSI)	31 (500)	0.45 (1880)
6	Exterior Insulation	Varies	-	R-5 to R-15 (0.88 RSI to 2.64 RSI)	1.8 (28)	0.29 (1220)
7	5' (1.5m) x 6' (1.8m) Aluminum window: double glazed & thermally broken ² , double glazed IGU UIGU = 0.32 BTU/hr.ft ² ·°F (1.82 W/m ² K)					
8	1x3 Wood Strapping	3/4" (19)	0.69 (0.10)	-	31 (500)	0.45 (1880)
9	Steel Fasteners (16" o.c.)	0.35" (9) Ø	347 (50)	-	489 (7830)	0.12 (500)
10	Fiber Cement Board Cladding with 3/4" (19mm) vented airspace incorporated into exterior heat transfer coefficient					
11	Aluminum Flashing	18 Gauge	1109 (160)	-	171 (2739)	0.21 (900)
12	Exterior Film ¹	-	-	R-0.2 to R-0.7 (0.03 RSI to 0.12 RSI)	-	-

¹ Value selected from table 1, p. 26.1 of 2009 ASHRAE Handbook – Fundamentals depending on surface orientation

² The thermal conductivity for air spaces within window framing was found using ISO 10077-2

Detail 8.4.1

Exterior and Interior Insulated 2x6 Wood Stud (16" o.c.) Wall Assembly with Wood Strapping and Continuous Insulation Supporting Rainscreen Fiber Cement Board and R-19 Batt Insulation in Stud Cavity – Vented Low-slope Roof & Parapet Intersection

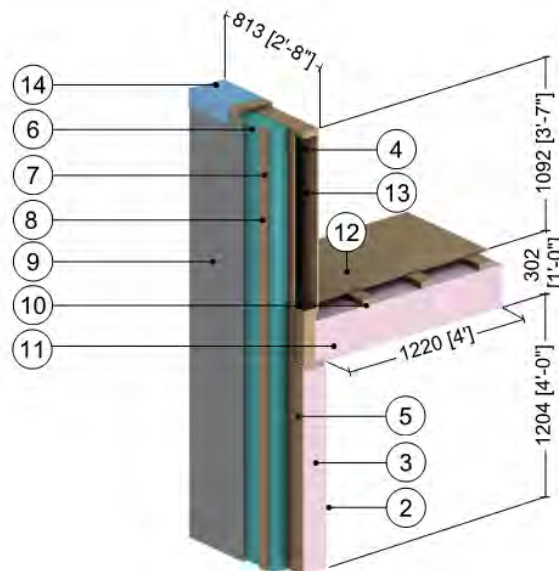

ID	Component	Thickness Inches (mm)	Conductivity Btu·in / ft ² ·hr·°F (W/m K)	Nominal Resistance hr·ft ² ·°F/Btu (m ² K/W)	Density lb/ft ³ (kg/m ³)	Specific Heat Btu/lb·°F (J/kg K)
1	Interior Film ¹	-	-	R-0.6 to R-0.9 (0.11 RSI to 0.16 RSI)	-	-
2	Gypsum Board	1/2" (13)	1.1 (0.16)	R-0.5 (0.08 RSI)	50 (800)	0.26 (1090)
3	Fiberglass Batt Insulation	5 1/2" (140)	0.29 (0.042)	R-19 (3.3 RSI)	0.9 (14)	0.17 (710)
4	2x6 Wood Stud (16" o.c.)	3 1/2" (140)	0.69 (0.10)	-	31 (500)	0.45 (1880)
5	Exterior Wood Sheathing	1/2" (13)	0.69 (0.10)	R-0.7 (0.13 RSI)	31 (500)	0.45 (1880)
6	Exterior Insulation	Varies	-	R-0 to R-15 (0.00 RSI to 2.64 RSI)	1.8 (28)	0.29 (1220)
7	1x3 Wood Strapping	3/4" (19)	0.69 (0.10)	-	31 (500)	0.45 (1880)
8	Steel Fasteners (16" o.c.)	0.35" (9) Ø	347 (50)	-	489 (7830)	0.12 (500)
9	Fiber Cement Board Cladding with 3/4" (19mm) vented airspace incorporated into exterior heat transfer coefficient					
10	Roof Wood Framing	-	0.69 (0.10)	-	31 (500)	0.45 (1880)
11	Fiberglass Roof Insulation	9 1/4" (235)	0.3 (0.04)	R-30 (5.28 RSI)	0.9 (14)	0.17 (710)
12	Roof Wood Sheathing	1/2" (13)	0.69 (0.10)	R-0.7 (0.12 RSI)	31 (500)	0.45 (1880)
13	Air Cavity	3 1/2" (89)	-	R-0.9 (0.16 RSI)	0.075 (1.2)	0.24 (1000)
14	Steel Cap Flashing	18 Gauge	430 (62)	-	489 (7830)	0.12 (500)
Flashing & roof material are incorporated into exterior heat transfer coefficient						
15	Exterior Film ¹	-	-	R-0.7 (0.12 RSI)	-	-

¹ Value selected from table 1, p. 26.1 of 2009 ASHRAE Handbook – Fundamentals depending on surface orientation

Detail 8.4.2

Exterior and Interior Insulated 2x6 Wood Stud (16" o.c.) Wall Assembly with Wood Strapping and Continuous Insulation Supporting Fiber Cement Board and R-19 Batt Insulation in Stud Cavity – Sloped Wood Framed Roof & Wall Intersection with Insulation at Ceiling

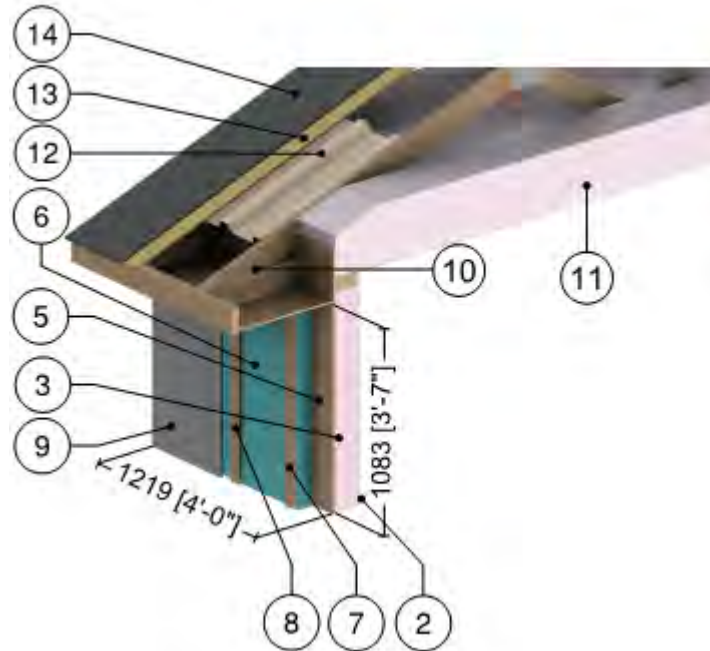

ID	Component	Thickness Inches (mm)	Conductivity Btu-in / ft ² ·hr·°F (W/m K)	Nominal Resistance hr·ft ² ·°F/Btu (m ² K/W)	Density lb/ft ³ (kg/m ³)	Specific Heat Btu/lb·°F (J/kg K)
1	Interior Film ¹	-	-	R-0.6 to R-0.7 (0.12 RSI to 0.12 RSI)	-	-
2	Gypsum Board	1/2" (13)	1.1 (0.16)	R-0.5 (0.08 RSI)	50 (800)	0.26 (1090)
3	Fiberglass Batt Insulation	5 1/2" (140)	0.29 (0.042)	R-19 (3.3 RSI)	0.9 (14)	0.17 (710)
4	2x6 Wood Stud (16" o.c.)	5 1/2" (140)	0.69 (0.10)	-	31 (500)	0.45 (1880)
5	Exterior Wood Sheathing	1/2" (13)	0.69 (0.10)	R-0.7 (0.12 RSI)	31 (500)	0.45 (1880)
6	Exterior Insulation	Varies	-	R-0 to R-15 (0.00 RSI to 2.64 RSI)	1.8 (28)	0.29 (1220)
7	1x3 Wood Strapping	3/4" (19)	0.69 (0.10)	-	31 (500)	0.45 (1880)
8	Steel Fasteners (16" o.c.)	0.35" (9) Ø	347 (50)	-	489 (7830)	0.12 (500)
9	Fiber Cement Board Cladding with 3/4" (19mm) vented airspace incorporated into exterior heat transfer coefficient					
10	Roof Truss (24" o.c.)	-	0.69 (0.10)	-	31 (500)	0.45 (1880)
11	Attic Insulation	9" (228)	0.29 (0.042)	R-30 (5.3 RSI)	0.9 (14)	0.17 (710)
12	Baffle	0.050" (1.3)	1.2 (0.17)	-	86 (1390)	0.24 (1000)
13	Roof Sheathing	1/2" (13)	0.69 (0.10)	R-0.7 (0.12 RSI)	31 (500)	0.45 (1880)
14	Asphalt Shingles	-	-	R-0.45 (0.08 RSI)	57 (920)	0.3 (1260)
15	Exterior Film (left side) ¹	-	-	R-0.2 (0.03 RSI)	-	-

¹ Value selected from table 1, p. 26.1 of 2009 ASHRAE Handbook – Fundamentals depending on surface orientation

Detail 8.4.3

Exterior and Interior Insulated 2x6 Wood Stud (16" o.c.) Wall Assembly with Wood Strapping and Continuous Insulation Supporting Rainscreen Fiber Cement Board and R-19 Batt Insulation in Stud Cavity – Sloped Wood Framed Roof & Wall Intersection with Insulation at Roof Sheathing

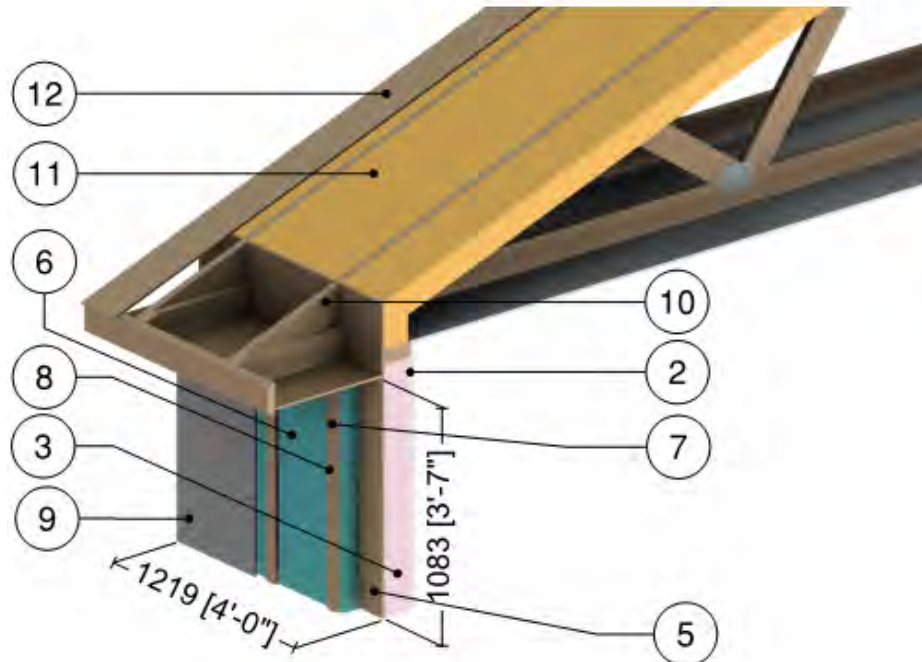

ID	Component	Thickness Inches (mm)	Conductivity Btu-in / ft ² ·hr·°F (W/m K)	Nominal Resistance hr·ft ² ·°F/Btu (m ² K/W)	Density lb/ft ³ (kg/m ³)	Specific Heat Btu/lb·°F (J/kg K)
1	Interior Film ¹	-	-	R-0.6 to R-0.7 (0.12 RSI to 0.12 RSI)	-	-
2	Gypsum Board	1/2" (13)	1.1 (0.16)	R-0.5 (0.08 RSI)	50 (800)	0.26 (1090)
3	Fiberglass Batt Insulation	5 1/2" (140)	0.29 (0.042)	R-19 (3.3 RSI)	0.9 (14)	0.17 (710)
4	2x6 Wood Stud (16" o.c.)	5 1/2" (140)	0.69 (0.10)	R-7.9 (1.4 RSI)	31 (500)	0.45 (1880)
5	Exterior Wood Sheathing	1/2" (13)	0.69 (0.10)	R-0.7 (0.12 RSI)	31 (500)	0.45 (1880)
6	Exterior Insulation	Varies	-	R-0 to R-15 (0.00 RSI to 2.64 RSI)	1.8 (28)	0.29 (1220)
7	1x3 Wood Strapping	3/4" (19)	0.69 (0.10)	-	31 (500)	0.45 (1880)
8	Steel Fasteners (16" o.c.)	0.35" (9) Ø	347 (50)	-	489 (7830)	0.12 (500)
9	Fiber Cement Board Cladding with 3/4" (19mm) vented airspace incorporated into exterior heat transfer coefficient					
10	Roof Truss (24" o.c.)	-	0.69 (0.10)	-	31 (500)	0.45 (1880)
11	Polyurethane Foam Insulation	5" (127)	0.17 (0.024)	R-30 (5.3 RSI)	1.8 (28)	0.29 (1220)
12	Roof Wood Sheathing	1/2" (13)	0.69 (0.10)	R-0.7 (0.12 RSI)	31 (500)	0.45 (1880)
13	Exterior Film ¹	-	-	R-0.2 (0.03 RSI)	-	-

¹ Value selected from table 1, p. 26.1 of 2009 ASHRAE Handbook – Fundamentals depending on surface orientation

Detail 8.4.4

Ventilated Wood Frame Low Slope Roof - Masonry Firewall Intersection

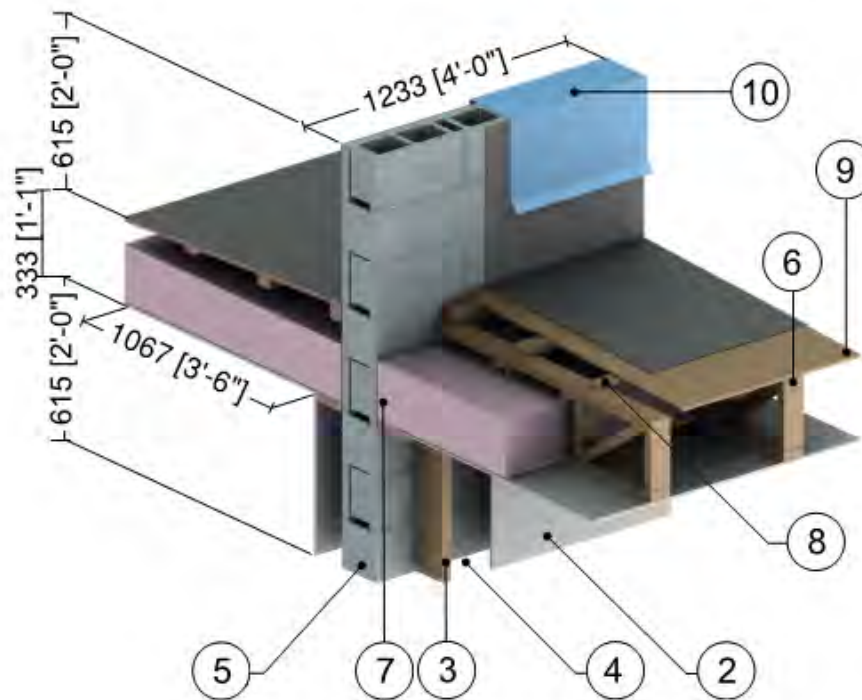

ID	Component	Thickness Inches (mm)	Conductivity Btu·in / ft ² ·hr·°F (W/m K)	Nominal Resistance hr·ft ² ·°F/Btu (m ² K/W)	Density lb/ft ³ (kg/m ³)	Specific Heat Btu/lb·°F (J/kg K)
1	Interior Film ¹	-	-	R-0.6 to R-0.7 (0.11 RSI to 0.12 RSI)	-	-
2	Gypsum Board	1/2" (13)	1.1 (0.16)	R-0.5 (0.08 RSI)	50 (800)	0.26 (1090)
3	2x6 Wood Studs (16" o.c.) and Top Plate	5 1/2" (140)	0.69 (0.10)	-	31 (500)	0.45 (1880)
4	Air Cavity	5 1/2" (140)	-	R-0.9 (0.16 RSI)	0.075 (1.2)	0.24 (1000)
5	Standard Concrete Block	8" (203)	3.5 (0.5)	-	119 (1900)	0.19 (800)
6	2x4 Parallel Wood Truss	-	0.69 (0.10)	-	31 (500)	0.45 (1880)
7	Roof Insulation	8 3/4" (222)	0.29 (0.04)	R-30 (5.3 RSI)	0.9 (14)	0.17 (710)
8	Wood Purlins (16" o.c.)	-	0.69 (0.10)	-	31 (500)	0.45 (1880)
9	Roof Wood Sheathing	1/2" (13)	0.69 (0.10)	R-0.6 (0.10 RSI)	50 (800)	0.26 (1090)
10	Steel Cap Flashing	18 Gauge	430 (62)	-	489 (7830)	0.12 (500)
11	Exterior Film ¹	-	-	R-0.2 (0.03 RSI)	-	-

¹ Value selected from table 1, p. 26.1 of 2009 ASHRAE Handbook – Fundamentals depending on surface orientation

² The thermal conductivity of air spaces within framing was found using ISO 100077-2

Detail 8.4.5

Exterior Insulated Cross Laminated Timber (CLT) Wall Assembly with Continuous Rigid Insulation Supporting Fiber Cement Board – Low-Slope Roof & Parapet Intersection

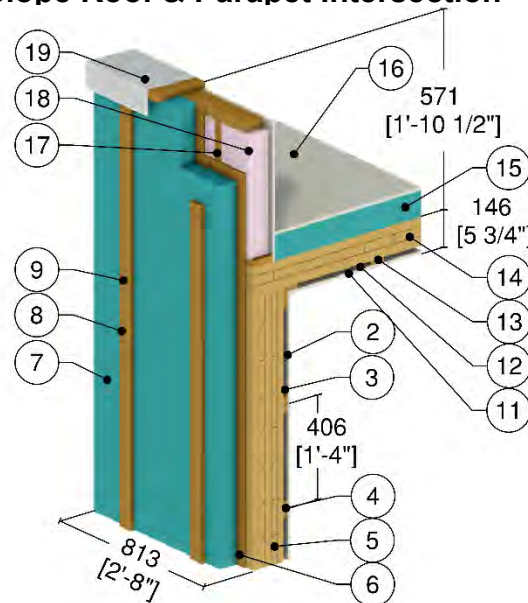

ID	Component	Thickness Inches (mm)	Conductivity Btu-in / ft ² ·hr·°F (W/m K)	Nominal Resistance hr·ft ² ·°F/Btu (m ² K/W)	Density lb/ft ³ (kg/m ³)	Specific Heat Btu/lb·°F (J/kg K)
1	Interior Film ¹	-	-	R-0.6 to R-0.7 (0.11 to 0.12 RSI)	-	-
2	Gypsum Board	1/2" (13)	1.1 (0.16)	R-0.5 (0.08 RSI)	50 (800)	0.26 (1090)
3	Air in Cavity	3/4" (19)	-	R-0.9 (0.16 RSI)	0.075 (1.2)	0.24 (1000)
4	1x3 Wood Strapping (16" o.c.)	3/4" (19)	0.69 (0.10)	-	31 (500)	0.45 (1880)
5	Cross Laminated Timber Wall	5 1/2" (140)	0.83 (0.12)	R-6.6 (1.16 RSI)	31 (500)	0.45 (1880)
6	Plywood Sheathing	3/8" (9.5)	0.69 (0.10)	R-0.5 (0.10 RSI)	31 (500)	0.45 (1880)
7	Exterior Insulation	Varies	-	R-15 to R-25 (2.64 to 4.40 RSI)	1.8 (28)	0.29 (1220)
8	1x3 Wood Strapping (16" o.c.)	3/4" (19)	0.69 (0.10)	-	31 (500)	0.45 (1880)
9	#14 Steel Fasteners (12" o.c.)	0.24" (6.2) Ø	347 (50)	-	489 (7830)	0.12 (500)
10	Fiber Cement Board Cladding with 3/4" (19mm) vented airspace incorporated into exterior heat transfer coefficient					
11	Roof Gypsum Board	1/2" (13)	1.1 (0.16)	R-0.5 (0.08 RSI)	50 (800)	0.26 (1090)
12	Air in Roof Cavity	3/4" (19)	-	R-0.9 (0.16 RSI)	0.075 (1.2)	0.24 (1000)
13	1x3 Wood Strapping (16" o.c.)	3/4" (19)	0.69 (0.10)	-	31 (500)	0.45 (1880)
14	Cross Laminated Timber Roof	4 1/2" (114)	0.83 (0.12)	R-5.4 (0.95 RSI)	31 (500)	0.45 (1880)
15	Roof Insulation	Varies	-	R-20 to R-50 (3.52 to 8.81 RSI)	1.8 (28)	0.29 (1220)
16	Gypsum Top Board	1/2" (13)	1.1 (0.16)	R-0.5 (0.08 RSI)	50 (800)	0.26 (1090)
17	2x4 Roof Wood Framing	3 1/2" (89)	0.69 (0.10)	-	31 (500)	0.45 (1880)
18	Fiberglass Batt Insulation	3 1/2" (89)	0.042 (0.29)	R-12 (2.11 RSI)	0.9 (14)	0.17 (710)
19	Steel Cap Flashing	18 Gauge	430 (62)	-	489 (7830)	0.12 (500)
20	Exterior Film ¹	-	-	R-0.2 to R-0.7 (0.03 to 0.12 RSI)	-	-

¹ Value selected from table 1, p. 26.1 of 2009 ASHRAE Handbook – Fundamentals depending on surface orientation

Detail 8.5.1

Exterior and Interior Insulated 2x6 Wood Stud (16" o.c.) Wall Assembly with Wood Strapping Supporting and Continuous Insulation Fiber Cement Board and R-19 Batt Insulation in Stud Cavity – Corner Intersection

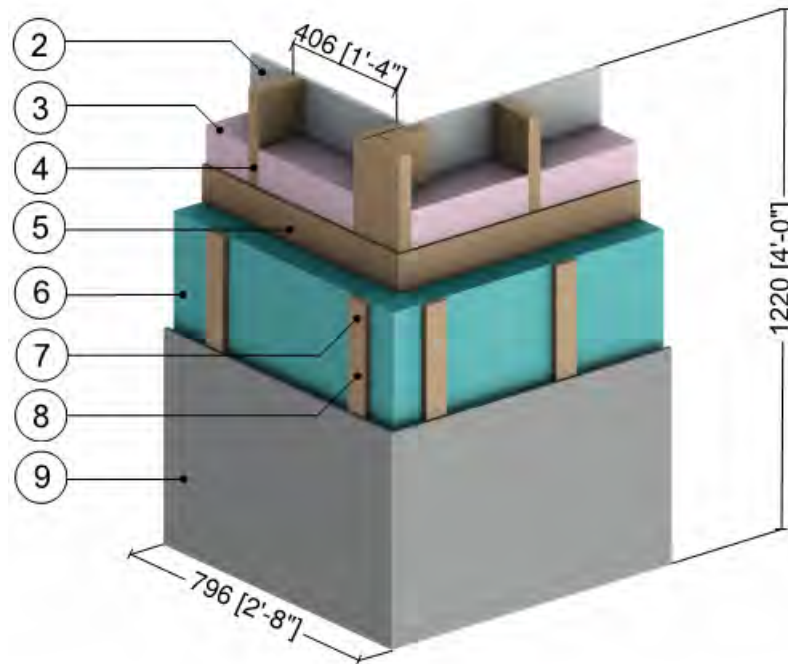

ID	Component	Thickness Inches (mm)	Conductivity Btu·in / ft ² ·hr·°F (W/m K)	Nominal Resistance hr·ft ² ·°F/Btu (m ² K/W)	Density lb/ft ³ (kg/m ³)	Specific Heat Btu/lb·°F (J/kg K)
1	Interior Film ¹	-	-	R-0.7 (0.12 RSI)	-	-
2	Gypsum Board	1/2" (16)	1.1 (0.16)	R-0.5 (0.08 RSI)	50 (800)	0.26 (1090)
3	Fiberglass Batt Insulation	5 1/2" (140)	0.29 (0.042)	R-19 (3.3 RSI)	0.9 (14)	0.17 (710)
4	2x6 Wood Stud (16" o.c.)	5 1/2" (140)	0.69 (0.10)	-	31 (500)	0.45 (1880)
5	Exterior Wood Sheathing	1/2" (16)	0.69 (0.10)	R-0.6 (0.10 RSI)	31 (500)	0.45 (1880)
6	Exterior Insulation	Varies	-	R-0 to R-15 (0.00 RSI to 2.64 RSI)	1.8 (28)	0.29 (1220)
7	1x3 Wood Strapping	3/4" (19)	0.69 (0.10)	-	31 (500)	0.45 (1880)
8	Steel Fasteners (16" o.c.)	-	347 (50)	-	489 (7830)	0.12 (500)
9	Fiber Cement Board Cladding with 3/4" (19mm) vented airspace incorporated into exterior heat transfer coefficient					
10	Exterior Film ¹	-	-	R-0.7 (0.12 RSI)	-	-

¹ Value selected from table 1, p. 26.1 of 2009 ASHRAE Handbook – Fundamentals depending on surface orientation

Detail 8.5.2

Interior Insulated Double Framed Wall 2x6 and 2x4 Wood Stud (16" o.c.) Wall Assembly with 1" Gap – Corner Intersection

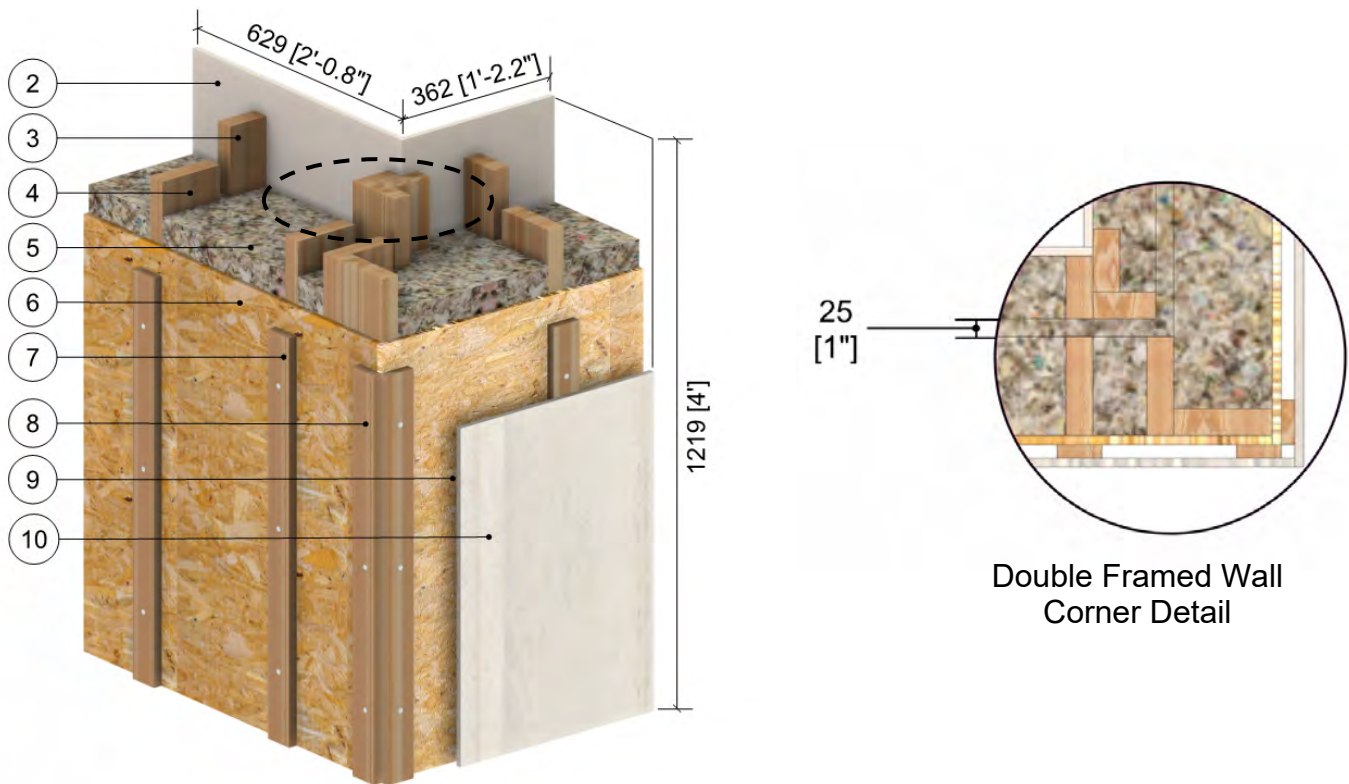

Double Framed Wall
Corner Detail

ID	Component	Thickness Inches (mm)	Conductivity Btu·in / ft ² ·hr·°F (W/m K)	Nominal Resistance hr·ft ² ·°F/Btu (m ² K/W)	Density lb/ft ³ (kg/m ³)	Specific Heat Btu/lb·°F (J/kg K)
1	Interior Film ¹	-	-	R-0.7 (0.12 RSI)	-	-
2	Gypsum Board	1/2" (13)	1.1 (0.16)	R-0.5 (0.08 RSI)	50 (800)	0.26 (1090)
3	2x4 Wood Stud (16" o.c.)	3 1/2" (89)	0.69 (0.10)	-	31 (500)	0.45 (1880)
4	2x6 Wood Stud (16" o.c.)	5 1/2" (140)	0.69 (0.10)	-	31 (500)	0.45 (1880)
5	Fill Insulation	10" (305)	Varies	R-35.0 to R-60.0 (6.16 RSI to 10.57 RSI)	-	-
6	Exterior Plywood Sheathing	1/2" (13)	0.69 (0.10)	R-0.7 (0.13 RSI)	31 (500)	0.45 (1880)
7	Wood Strapping (1" x 3")	3/4" (19)	0.69 (0.10)	-	31 (500)	0.45 (1880)
8	Steel Fasteners (12" o.c.)	0.43" (11) Ø	347 (50)	-	489 (7830)	0.12 (500)
9	Rainscreen Cavity	3/4" (19)	-	R-0.4 (0.07 RSI)	0.075 (1.2)	0.24 (1000)
10	Fiber Cement Board	1/2" (13)	4.86 (0.7)	R-0.1 (0.02 RSI)	-	-
11	Exterior Film ¹	-	-	R-0.2 (0.03 RSI)	-	-

¹ Value selected from table 1, p. 26.1 of 2009 ASHRAE Handbook – Fundamentals depending on surface orientation

Detail 8.6.1

Wood-frame Sliding Door – Concrete Floor Intersection for Unheated Spaces (Parking Garages)

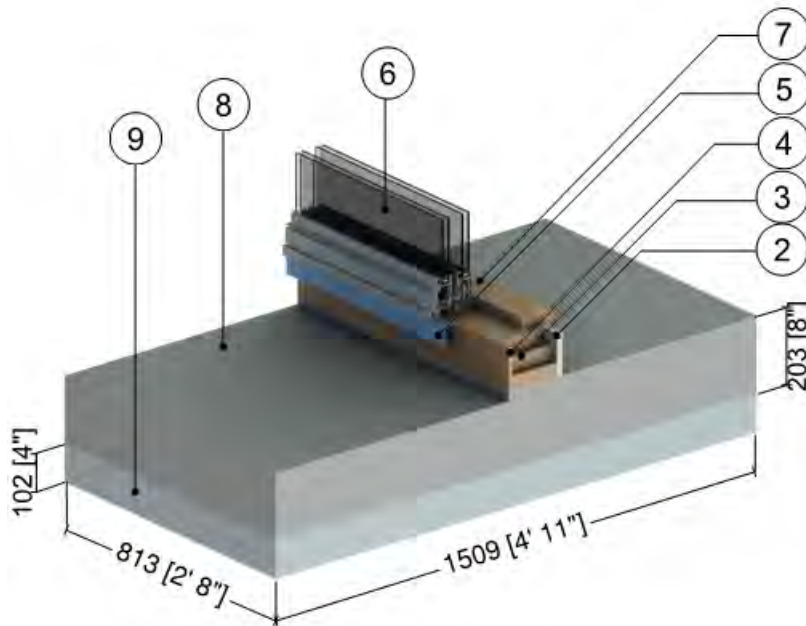

ID	Component	Thickness Inches (mm)	Conductivity Btu·in / ft ² ·hr·°F (W/m K)	Nominal Resistance hr·ft ² ·°F/Btu (m ² K/W)	Density lb/ft ³ (kg/m ³)	Specific Heat Btu/lb·°F (J/kg K)
1	Interior Film ¹	-	-	R-0.7 (0.12 RSI)	-	-
2	Gypsum Board	1/2" (13)	1.1 (0.16)	R-0.5 (0.08 RSI)	50 (800)	0.26 (1090)
3	2x6 Wood Plates	5 1/2" (140)	0.69 (0.10)	-	31 (500)	0.45 (1880)
4	Exterior Wood Sheathing	1/2" (13)	0.69 (0.10)	R-0.7 (0.13 RSI)	31 (500)	0.26 (1090)
5	Steel Flashing	28 Gauge	430 (62)	-	489 (7830)	0.12 (500)
6	Aluminum Sliding Door: double glazed and thermally broken ² , double glazed IGU U _{IGU} = 0.32 BTU/hr.ft ² .°F (1.82 W/m ² K)					
7	Wood Sill	1/2" (13)	0.69 (0.10)	-	31 (500)	0.45 (1880)
8	Concrete Slab	8" (203)	12.5 (1.8)	-	141 (2250)	0.20 (850)
9	Spray Applied Fiberglass insulation	4" (102)	0.20 (0.029)	R-20 (3.5 RSI)	0.9 (14)	0.12 (500)
10	Exterior Film ¹	-	-	R-0.2 to R-0.7 (0.03 RSI to 0.12 RSI)	-	-

¹ Value selected from table 1, p. 26.1 of 2009 ASHRAE Handbook – Fundamentals depending on surface orientation

² The thermal conductivity for air spaces within window framing was found using ISO 10077-2

Detail 8.6.2

Exterior and Interior Insulated 2x6 Wood Stud (16" o.c.) Wall Assembly with Continuous Insulation and Wood Strapping Supporting Fiber Cement Board and R-19 Batt Insulation in Stud Cavity – Rim Joist and Interior Insulated At-Grade Foundation Wall Intersection

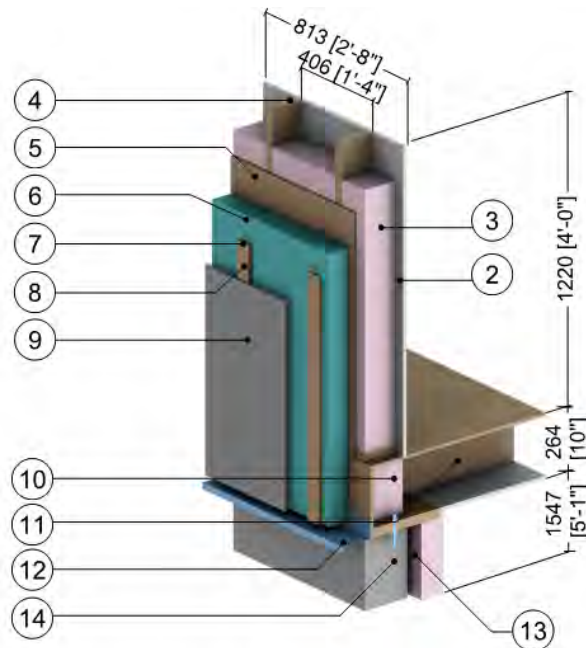

ID	Component	Thickness Inches (mm)	Conductivity Btu·in / ft ² ·hr·°F (W/m K)	Nominal Resistance hr·ft ² ·°F/Btu (m ² K/W)	Density lb/ft ³ (kg/m ³)	Specific Heat Btu/lb·°F (J/kg K)
1	Interior Film ¹	-	-	R-0.7 to R-0.9 (0.12 RSI to 0.16 RSI)	-	-
2	Gypsum Board	1/2" (13)	1.1 (0.16)	R-0.5 (0.08 RSI)	50 (800)	0.26 (1090)
3	Fiberglass Batt Insulation	5 1/2" (140)	0.29 (0.042)	R-19 (3.3 RSI)	0.9 (14)	0.17 (710)
4	2x6 Wood Stud (16" o.c.)	5 1/2" (140)	0.69 (0.10)	-	31 (500)	0.45 (1880)
5	Exterior Plywood Sheathing	1/2" (13)	0.69 (0.10)	R-0.7 (0.13 RSI)	31 (500)	0.45 (1880)
6	Exterior Insulation	Varies	-	R-5 to R-15 (0.88 RSI to 2.64 RSI)	1.8 (28)	0.29 (1220)
7	1x3 Wood Strapping	1 1/2" (38)	0.69 (0.10)	-	31 (500)	0.45 (1880)
8	Steel Fasteners (16" o.c.)	0.35" (9) Ø	347 (50)	-	489 (7830)	0.12 (500)
9	Fiber Cement Board Cladding with 3/4" (19mm) vented airspace incorporated into exterior heat transfer coefficient					
10	Fiberglass Batt Insulation at Joist	5 1/2" (140)	0.29 (0.042)	R-19 (3.3 RSI)	0.9 (14)	0.17 (710)
11	2x10 Wood Joist (16" o.c.)	9 1/4" (235)	0.69 (0.10)	-	31 (500)	0.45 (1880)
12	Steel Flashing	18 Gauge	430 (62)	-	489 (7830)	0.12 (500)
13	2x4 Wood Stud (16" o.c.)	3 1/2" (89)	0.69 (0.10)	-	31 (500)	0.45 (1880)
14	Concrete Foundation Wall	8" (203)	12.5 (1.8)	R-0.6 (0.11 RSI)	140 (2250)	0.20 (850)
15	Exterior Film ^{1,2}	-	-	R-0.7 (0.12 RSI)	-	-

¹ Value selected from table 1, p. 26.1 of 2009 ASHRAE Handbook – Fundamentals depending on surface orientation

² Except at foundation wall adjacent soil

Detail 8.6.3

Exterior and Interior Insulated 2x6 Wood Stud (16" o.c.) Wall Assembly with Continuous Insulation and Wood Strapping Supporting Fiber Cement Board and R-19 Batt Insulation in Stud Cavity – Rim Joist and Exterior Insulated At-Grade Foundation Wall Intersection

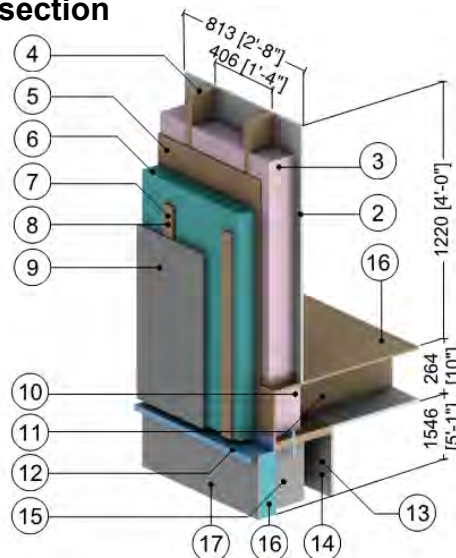

ID	Component	Thickness Inches (mm)	Conductivity Btu·in / ft ² ·hr·°F (W/m K)	Nominal Resistance hr·ft ² ·°F/Btu (m ² K/W)	Density lb/ft ³ (kg/m ³)	Specific Heat Btu/lb·°F (J/kg K)
1	Interior Film ¹	-	-	R-0.7 to R-0.9 (0.12 RSI to 0.16 RSI)	-	-
2	Gypsum Board	1/2" (13)	1.1 (0.16)	R-0.5 (0.08 RSI)	50 (800)	0.26 (1090)
3	Fiberglass Batt Insulation	5 1/2" (140)	0.29 (0.042)	R-19 (3.3 RSI)	0.9 (14)	0.17 (710)
4	2x6 Wood Stud (16" o.c.)	5 1/2" (140)	0.69 (0.10)	-	31 (500)	0.45 (1880)
5	Exterior Wood Sheathing	1/2" (13)	0.69 (0.10)	R-0.5 (0.08 RSI)	31 (500)	0.45 (1880)
6	Exterior Insulation	Varies	-	R-5 to R-15 (0.88 RSI to 2.64 RSI)	1.8 (28)	0.29 (1220)
7	1x3 Wood Strapping	3/4" (19)	0.69 (0.10)	-	31 (500)	0.45 (1880)
8	Steel Fasteners (16" o.c.)	0.35" (9) Ø	347 (50)	-	489 (7830)	0.12 (500)
9	Fiber Cement Board Cladding with 3/4" (19mm) vented airspace incorporated into exterior heat transfer coefficient					
10	Fiberglass Batt Insulation at Joists	5 1/2" (140)	0.29 (0.042)	R-19 (3.3 RSI)	0.9 (14)	0.17 (710)
11	2x10 Wood Joists (16" o.c.)	9 1/4" (235)	0.69 (0.10)	-	31 (500)	0.45 (1880)
12	Steel Flashing	18 Gauge	430 (62)	-	489 (7830)	0.12 (500)
13	2x4 Wood Stud (16" OC)	3 1/2" (89)	0.69 (0.10)	-	31 (500)	0.45 (1880)
14	Air Cavity	3 1/2" (89)	-	R-0.9 (0.16 RSI)	0.075 (1.2)	0.24 (1000)
15	Concrete Foundation Wall	8" (203)	12.5 (1.8)	R-0.6 (0.11 RSI)	140 (2250)	0.20 (850)
16	Rigid Exterior Insulation	2 1/2" (64)	-	R-12.5 (2.2 RSI)	1.8 (28)	0.29 (1220)
17	Protective Coating or Flashing	-	-	-	-	-
18	Exterior Film ^{1,2}	-	-	R-0.7 (0.12 RSI)	-	-

¹ Value selected from table 1, p. 26.1 of 2009 ASHRAE Handbook – Fundamentals depending on surface orientation

² Except at foundation wall adjacent soil

Detail 8.6.4

Exterior and Interior Insulated 2x6 Wood Stud (16" o.c.) Wall Assembly with Shelf Angle & Brick Ties Supporting Brick Veneer and R-19 Batt Insulation in Stud Cavity – Exterior Insulated At-Grade Foundation Wall Intersection

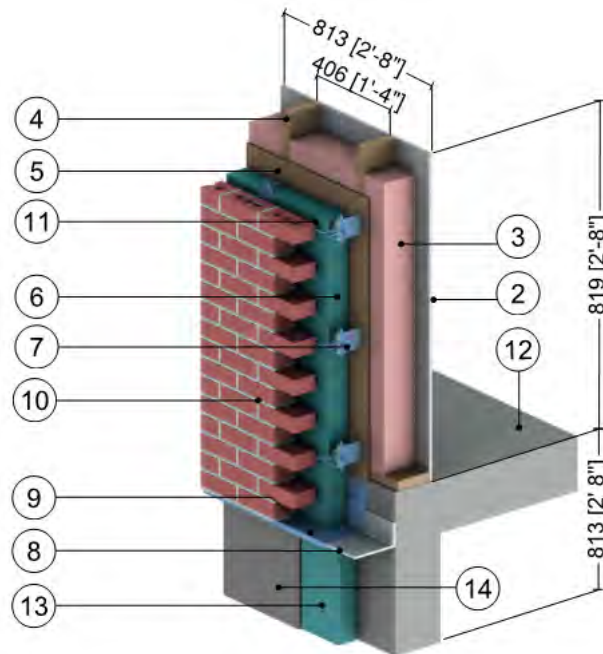

ID	Component	Thickness Inches (mm)	Conductivity Btu·in / ft ² ·hr·°F (W/m K)	Nominal Resistance hr·ft ² ·°F/Btu (m ² K/W)	Density lb/ft ³ (kg/m ³)	Specific Heat Btu/lb·°F (J/kg K)
1	Interior Film ¹	-	-	R-0.7 to R-0.9 (0.12 RSI to 0.16 RSI)	-	-
2	Gypsum Board	1/2" (13)	1.1 (0.16)	R-0.5 (0.08 RSI)	50 (800)	0.26 (1090)
3	Fiberglass Batt Insulation	5 1/2" (140)	0.29 (0.04)	R-19 (3.3 RSI)	0.9 (14)	0.17 (710)
4	2x6 Wood Stud (16" o.c.) with Bottom Plate	5 1/2" (140)	0.69 (0.10)	-	31 (500)	0.45 (1880)
5	Exterior Wood Sheathing	1/2" (16)	0.69 (0.10)	R-0.7 (0.12 RSI)	31 (500)	0.45 (1880)
6	Exterior Insulation	Varies	-	R-5 to R-15 (0.88 RSI to 2.64 RSI)	1.8 (28)	0.29 (1220)
7	Masonry Ties @ 16" (406) o.c.	14 Gauge	347 (50)	-	489 (7830)	0.12 (500)
8	Steel Shelf Angle	3/8" (10)	347 (50)	-	489 (7830)	0.12 (500)
9	Steel Flashing	20 Gauge	347 (50)	-	489 (7830)	0.12 (500)
10	Brick Veneer	3 5/8" (92)	5.4 (0.78)	-	120 (1920)	0.19 (720)
11	Air Cavity	1" (25)	-	R-0.9 (0.16 RSI)	0.075 (1.2)	0.24 (1000)
12	Concrete Slab & Foundation Wall	8" (203)	12.5 (1.8)	-	140 (2250)	0.20 (850)
13	Rigid Exterior Insulation	2 1/2" (64)	0.2 (0.03)	R-12.5 (2.2 RSI)	1.8 (28)	0.29 (1220)
14	Protective Coating or Flashing	-	-	-	-	-
15	Exterior Film ¹	-	-	R-0.2 (0.03 RSI)	-	-

¹ Value selected from table 1, p. 26.1 of 2009 ASHRAE Handbook – Fundamentals depending on surface orientation

² Except at foundation wall adjacent soil

Detail 8.6.5

Exterior Insulated Cross Laminated Timber (CLT) Wall Assembly with Continuous Rigid Insulation Supporting Fiber Cement Board – Concrete Slab and Exterior Insulated At-Grade Foundation Wall Intersection

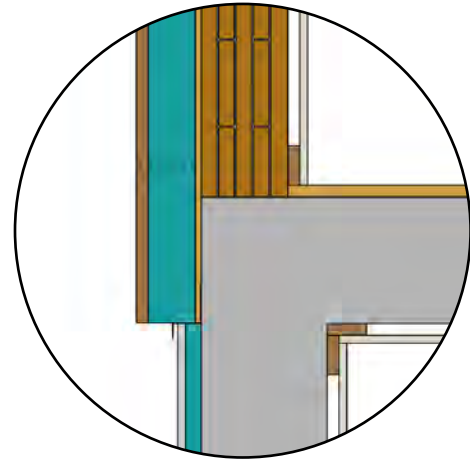
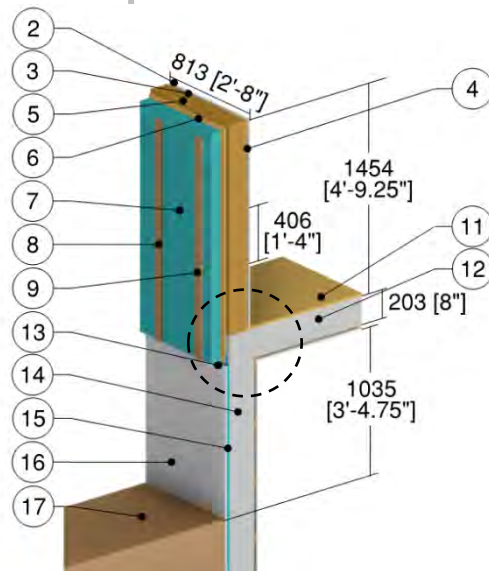

Concrete Slab and Wall Assembly Intersection

ID	Component	Thickness Inches (mm)	Conductivity Btu-in / ft ² ·hr·°F (W/m K)	Nominal Resistance hr·ft ² ·°F/Btu (m ² K/W)	Density lb/ft ³ (kg/m ³)	Specific Heat Btu/lb·°F (J/kg K)
1	Interior Film ¹	-	-	R-0.6 to R-0.9 (0.11 RSI to 0.16 RSI)	-	-
2	Gypsum Board	1/2" (13)	1.1 (0.16)	R-0.5 (0.08 RSI)	50 (800)	0.26 (1090)
3	Air in Cavity	3/4" (19)	-	R-0.9 (0.16 RSI)	0.075 (1.2)	0.24 (1000)
4	1x3 Wood Strapping (16" o.c.)	3/4" (19)	0.69 (0.10)	-	31 (500)	0.45 (1880)
5	Cross Laminated Timber Wall	5 1/2" (140)	0.83 (0.12)	R-6.6 (1.16 RSI)	31 (500)	0.45 (1880)
6	Plywood Sheathing	3/8" (9.5)	0.69 (0.10)	R-0.5 (0.10 RSI)	31 (500)	0.45 (1880)
7	Exterior Insulation	Varies	-	R-15 to R-25 (2.64 to 4.40 RSI)	1.8 (28)	0.29 (1220)
8	1x3 Wood Strapping (16" o.c.)	3/4" (19)	0.69 (0.10)	-	31 (500)	0.45 (1880)
9	#14 Steel Fasteners (12" o.c.)	0.24" (6.2) Ø	347 (50)	-	489 (7830)	0.12 (500)
10	Fiber Cement Board Cladding with 3/4" (19mm) vented airspace incorporated into exterior heat transfer coefficient					
11	Plywood Floor	3/4" (19)	0.69 (0.10)	-	31 (500)	0.45 (1880)
12	Concrete Slab	8" (203)	12.5 (1.8)	-	140 (2250)	0.20 (850)
13	Steel Flashing	18 Gauge	430 (62)	-	489 (7830)	0.12 (500)
14	Concrete Foundation Wall	8" (203)	12.5 (1.8)	R-0.6 (0.11 RSI)	140 (2250)	0.20 (850)
15	Foundation Wall Exterior Insulation	Varies	-	R-5 to R-20 (0.88 to 3.52 RSI)	1.8 (28)	0.29 (1220)
16	Cement Board	1/2" (13)	1.7 (0.25)	R-0.3 (0.051 RSI)	72 (1150)	0.20 (850)
17	Soil	-	14 (2.0)	-	-	-
18	Exterior Film ^{1,2}	-	-	R-0.2 to R-0.7 (0.03 to 0.12 RSI)	-	-

¹ Value selected from table 1, p. 26.1 of 2009 ASHRAE Handbook – Fundamentals depending on surface orientation

² Except at foundation wall adjacent soil

Detail 8.6.6

Interior Insulated Double Framed Wall 2x6 and 2x4 Wood Stud (16" o.c.) Wall Assembly with 2" Gap – Rim Joist and Split Insulated At-Grade Foundation Wall Intersection

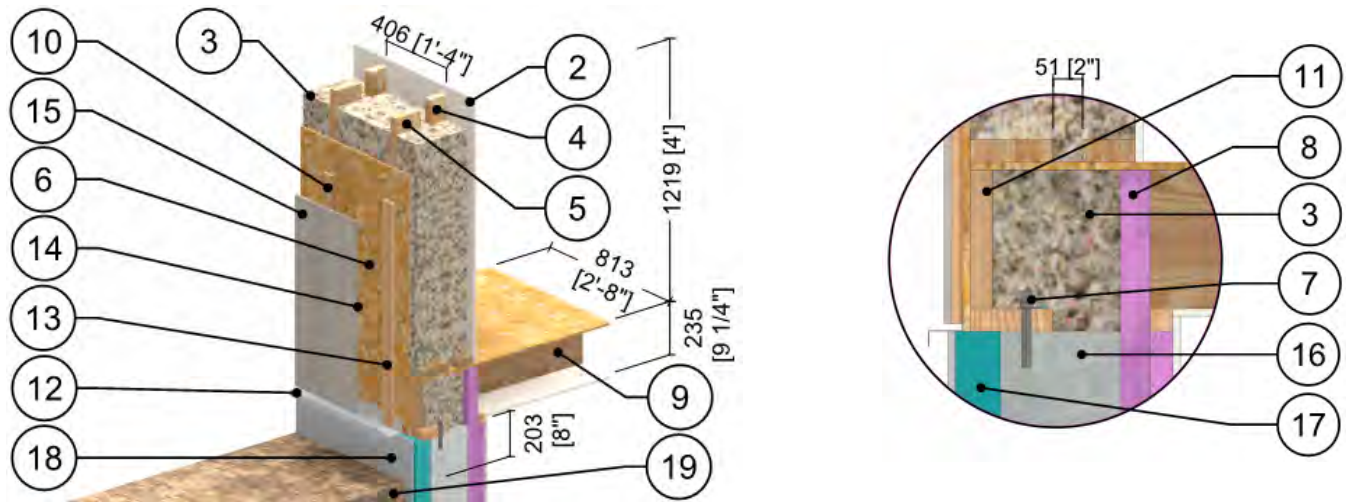

ID	Component	Thickness Inches (mm)	Conductivity Btu-in / ft ² ·hr·°F (W/m K)	Nominal Resistance hr·ft ² ·°F/Btu (m ² K/W)	Density lb/ft ³ (kg/m ³)	Specific Heat Btu/lb·°F (J/kg K)
1	Interior Film ¹	-	-	R-0.6 to R-0.9 (0.11 RSI to 0.16 RSI)	-	-
2	Gypsum Board	1/2" (13)	1.1 (0.16)	R-0.5 (0.08 RSI)	50 (800)	0.26 (1090)
3	Fill Insulation	11" (279)	Varies	-	-	-
4	2x4 Wood Stud (16" o.c.)	3 1/2" (89)	0.69 (0.10)	-	31 (500)	0.45 (1880)
5	2x6 Wood Stud (16" o.c.)	5 1/2" (140)	0.69 (0.10)	-	31 (500)	0.45 (1880)
6	Exterior Plywood Sheathing	1/2" (13)	0.69 (0.10)	R-0.7 (0.13 RSI)	31 (500)	0.45 (1880)
7	Stainless Steel Foundation Bolt	5/8" (16) Ø	118 (17)	-	500 (8000)	0.12 (500)
8	XPS Insulation	3 1/2" (89)	0.20 (0.029)	R-17.5 (3.08 RSI)	1.8 (28)	0.29 (1220)
9	2x10 Wood Joists (16" o.c.)	9 1/4" (235)	0.69 (0.10)	-	31 (500)	0.45 (1880)
10	Steel Fasteners (16" o.c.)	0.35" (9) Ø	347 (50)	-	489 (7830)	0.12 (500)
11	2x10 Rim Joist	1 1/2" (38)	0.69 (0.10)	-	31 (510)	0.45 (1880)
12	Steel Flashing	18 Gauge	430 (62)	-	489 (7830)	0.12 (500)
13	Wood Strapping (1" x 3")	3/4" (19)	0.69 (0.10)	-	31 (500)	0.45 (1880)
14	Rainscreen Cavity	3/4" (19)	-	R-0.4 (0.07 RSI)	0.075 (1.2)	0.24 (1000)
15	Fiber Cement Board	1/2" (13)	4.86 (0.7)	-	-	-
16	Foundation Wall Concrete	8" (203)	12.5 (1.8)	-	140 (2250)	0.20 (850)
17	Foundation Wall Exterior Insulation	3" (76)	0.20 (0.029)	R-15 (2.64 RSI)	1.8 (28)	0.29 (1220)
18	Cement Protection Board	1/2" (13)	1.7 (0.25)	R-0.3 (0.051 RSI)	72 (1150)	0.20 (850)
19	Soil	-	14 (2.0)	-	-	-
20	Exterior Film ^{1,2}	-	-	R-0.2 to R-0.7 (0.03 to 0.12 RSI)	-	-

¹ Value selected from table 1, p. 26.1 of 2009 ASHRAE Handbook – Fundamentals depending on surface orientation

² Except at foundation wall adjacent soil

Detail 8.6.7

Interior Insulated Double Framed Wall 2x6 and 2x4 Wood Stud (16" o.c.) Wall Assembly with 2" Gap – Insulated Rim Joist and Split Insulated At-Grade Foundation Wall Intersection

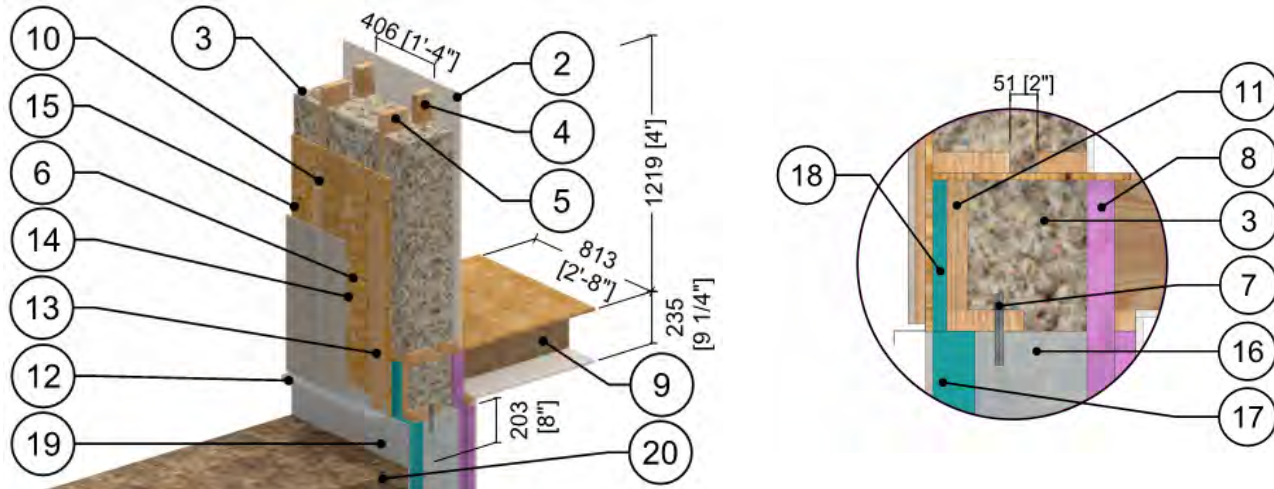

ID	Component	Thickness Inches (mm)	Conductivity Btu·in / ft ² ·hr·°F (W/m K)	Nominal Resistance hr·ft ² ·°F/Btu (m ² K/W)	Density lb/ft ³ (kg/m ³)	Specific Heat Btu/lb·°F (J/kg K)
1	Interior Film ¹	-	-	R-0.6 to R-0.9 (0.11 RSI to 0.16 RSI)	-	-
2	Gypsum Board	1/2" (13)	1.1 (0.16)	R-0.5 (0.08 RSI)	50 (800)	0.26 (1090)
3	Fill Insulation	11" (279)	Varies	-	-	-
4	2x4 Wood Stud (16" o.c.)	3 1/2" (89)	0.69 (0.10)	-	31 (500)	0.45 (1880)
5	2x6 Wood Stud (16" o.c.)	5 1/2" (140)	0.69 (0.10)	-	31 (500)	0.45 (1880)
6	Exterior Plywood Sheathing	1/2" (13)	0.69 (0.10)	R-0.7 (0.13 RSI)	31 (500)	0.45 (1880)
7	Stainless Steel Foundation Bolt	1/2" (13) Ø	118 (17)	-	500 (8000)	0.12 (500)
8	XPS Insulation	3 1/2" (89)	0.20 (0.029)	R-17.5 (3.08 RSI)	1.8 (28)	0.29 (1220)
9	2x10 Wood Joists (16" o.c.)	9 1/4" (235)	0.69 (0.10)	-	31 (500)	0.45 (1880)
10	Steel Fasteners (16" o.c.)	0.35" (9) Ø	347 (50)	-	489 (7830)	0.12 (500)
11	2x10 Rim Joist	1 1/2" (38)	0.69 (0.10)	-	31 (510)	0.45 (1880)
12	Steel Flashing	18 Gauge	430 (62)	-	489 (7830)	0.12 (500)
13	Wood Strapping (1" x 3")	3/4" (19)	0.69 (0.10)	-	31 (500)	0.45 (1880)
14	Rainscreen Cavity	3/4" (19)	-	R-0.4 (0.07 RSI)	0.075 (1.2)	0.24 (1000)
15	Fiber Cement Board	1/2" (13)	4.86 (0.7)	-	-	-
16	Foundation Wall Concrete	8" (203)	12.5 (1.8)	-	140 (2250)	0.20 (850)
17	Foundation Wall Exterior Insulation	3" (76)	0.20 (0.029)	R-15 (2.64 RSI)	1.8 (28)	0.29 (1220)
18	Rim Joist Insulation	1" (25)	0.20 (0.029)	R-5 (0.88 RSI)	1.8 (28)	0.29 (1220)
19	Cement Protection Board	1/2" (13)	1.7 (0.25)	R-0.3 (0.051 RSI)	72 (1150)	0.20 (850)
20	Soil	-	14 (2.0)	-	-	-
21	Exterior Film ^{1,2}	-	-	R-0.2 to R-0.7 (0.03 to 0.12 RSI)	-	-

¹ Value selected from table 1, p. 26.1 of 2009 ASHRAE Handbook – Fundamentals depending on surface orientation

² Except at foundation wall adjacent soil

Detail 8.6.8

Interior Insulated Double Framed Wall 2x6 and 2x4 Wood Stud (16" o.c.) Wall Assembly with 2" Gap and R28 ICF Foundation Wall – Rim Joist and Split Insulated At-Grade Foundation Wall Intersection

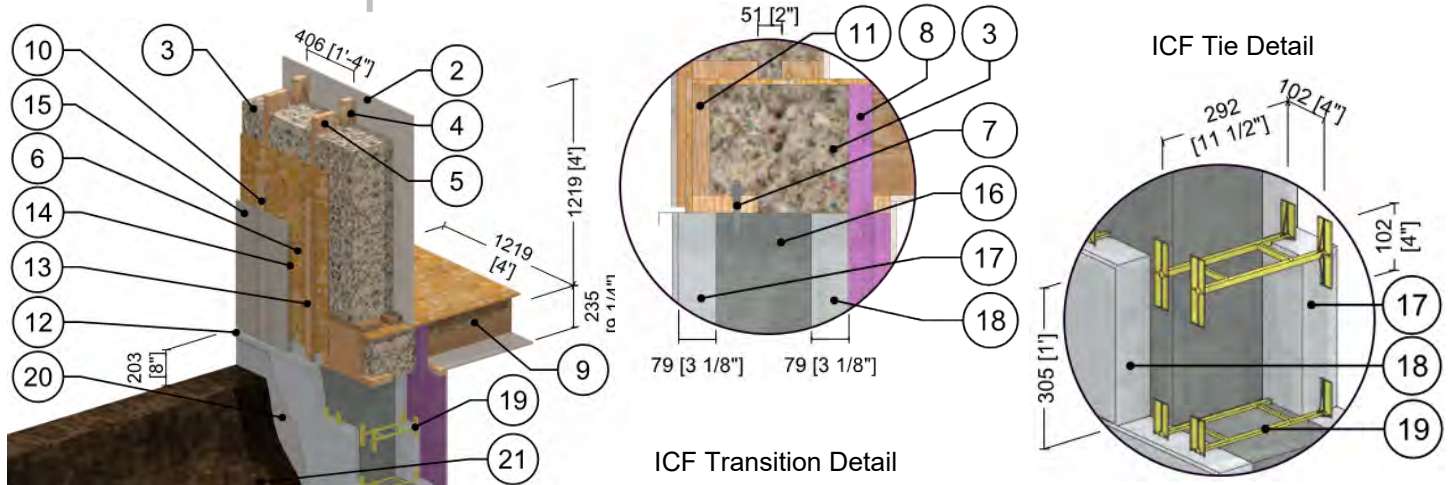

ID	Component	Thickness Inches (mm)	Conductivity Btu-in / ft ² ·hr·°F (W/m K)	Nominal Resistance hr·ft ² ·°F/Btu (m ² K/W)	Density lb/ft ³ (kg/m ³)	Specific Heat Btu/lb·°F (J/kg K)
1	Interior Film ¹	-	-	R-0.6 to R-0.9 (0.11 RSI to 0.16 RSI)	-	-
2	Gypsum Board	1/2" (13)	1.1 (0.16)	R-0.5 (0.08 RSI)	50 (800)	0.26 (1090)
3	Fill Insulation	11" (279)	Varies	-	-	-
4	2x4 Wood Stud (16" o.c.)	3 1/2" (89)	0.69 (0.10)	-	31 (500)	0.45 (1880)
5	2x6 Wood Stud (16" o.c.)	5 1/2" (140)	0.69 (0.10)	-	31 (500)	0.45 (1880)
6	Exterior Plywood Sheathing	1/2" (13)	0.69 (0.10)	R-0.7 (0.13 RSI)	31 (500)	0.45 (1880)
7	Stainless Steel Foundation Bolt	1/2" (13) Ø	118 (17)	-	500 (8000)	0.12 (500)
8	XPS Insulation	3 1/2" (89)	0.20 (0.029)	R-17.5 (3.08 RSI)	1.8 (28)	0.29 (1220)
9	2x10 Wood Joists (16" o.c.)	9 1/4" (235)	0.69 (0.10)	-	31 (500)	0.45 (1880)
10	Steel Fasteners (16" o.c.)	0.35" (9) Ø	347 (50)	-	489 (7830)	0.12 (500)
11	2x10 Rim Joist	1 1/2" (38)	0.69 (0.10)	-	31 (510)	0.45 (1880)
12	Steel Flashing	18 Gauge	430 (62)	-	489 (7830)	0.12 (500)
13	Wood Strapping (1" x 3")	3/4" (19)	0.69 (0.10)	-	31 (500)	0.45 (1880)
14	Rainscreen Cavity	3/4" (19)	-	R-0.4 (0.07 RSI)	0.075 (1.2)	0.24 (1000)
15	Fiber Cement Board	1/2" (13)	4.86 (0.7)	-	-	-
16	Foundation Wall Concrete	8" (203)	12.5 (1.8)	-	140 (2250)	0.20 (850)
17	ICF Insulation (Inboard)	3 1/8" (79)	0.25 (0.036)	R-12.5 (2.20 RSI)	66 (1060)	0.35 (1500)
18	ICF Insulation (Outboard)	3 1/8" (79)	0.25 (0.036)	R-12.5 (2.20 RSI)	66 (1060)	0.35 (1500)
19	ICF HDPE Tie (12" o.c.)	11 1/2" (292)	1.7 (0.25)	-	59 (950)	0.48 (2000)
20	Cement Protection Board	1/2" (13)	1.7 (0.25)	R-0.3 (0.051 RSI)	72 (1150)	0.20 (850)
21	Soil	-	14 (2.0)	-	-	-
22	Exterior Film ^{1,2}	-	-	R-0.2 to R-0.7 (0.03 to 0.12 RSI)	-	-

¹ Value selected from table 1, p. 26.1 of 2009 ASHRAE Handbook – Fundamentals depending on surface orientation

² Except at foundation wall adjacent soil



Detail 8.6.9

Interior Insulated Double Framed Wall 2x6 and 2x4 Wood Stud (16" o.c.) Wall Assembly with 2" Gap and R43 ICF Foundation Wall – Rim Joist and Split Insulated At-Grade Foundation Wall Intersection

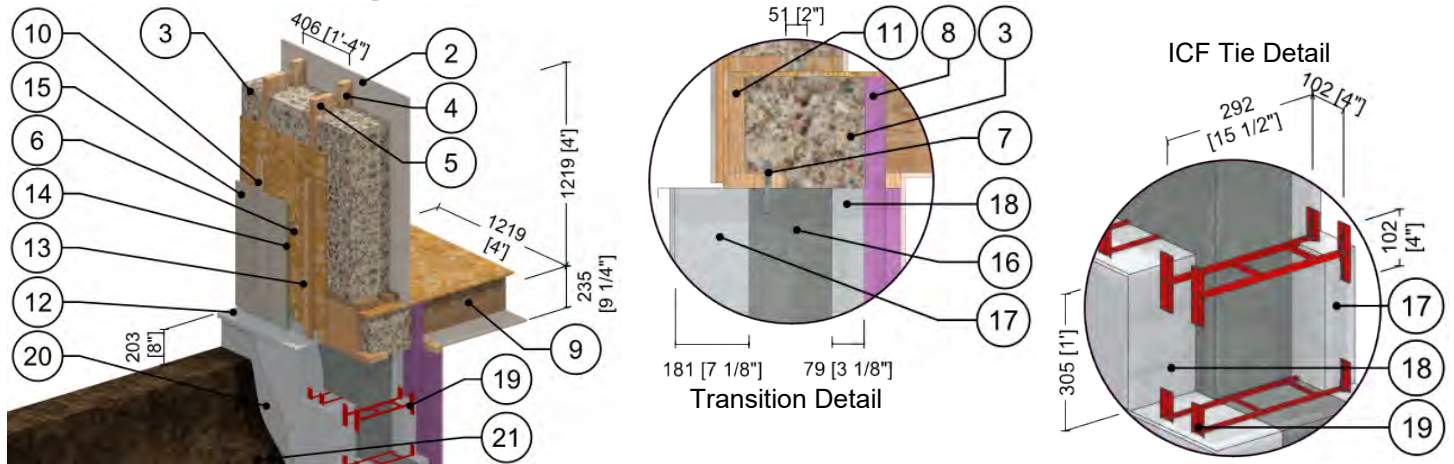

ID	Component	Thickness Inches (mm)	Conductivity Btu-in / ft ² ·hr·°F (W/m K)	Nominal Resistance hr·ft ² ·°F/Btu (m ² K/W)	Density lb/ft ³ (kg/m ³)	Specific Heat Btu/lb·°F (J/kg K)
1	Interior Film ¹	-	-	R-0.6 to R-0.9 (0.11 RSI to 0.16 RSI)	-	-
2	Gypsum Board	1/2" (13)	1.1 (0.16)	R-0.5 (0.08 RSI)	50 (800)	0.26 (1090)
3	Fill Insulation	11" (279)	Varies	-	-	-
4	2x4 Wood Stud (16" o.c.)	3 1/2" (89)	0.69 (0.10)	-	31 (500)	0.45 (1880)
5	2x6 Wood Stud (16" o.c.)	5 1/2" (140)	0.69 (0.10)	-	31 (500)	0.45 (1880)
6	Exterior Plywood Sheathing	1/2" (13)	0.69 (0.10)	R-0.7 (0.13 RSI)	31 (500)	0.45 (1880)
7	Stainless Steel Foundation Bolt	1/2" (13) Ø	118 (17)	-	500 (8000)	0.12 (500)
8	XPS Insulation	3 1/2" (89)	0.20 (0.029)	R-17.5 (3.08 RSI)	1.8 (28)	0.29 (1220)
9	2x10 Wood Joists (16" o.c.)	9 1/4" (235)	0.69 (0.10)	-	31 (500)	0.45 (1880)
10	Steel Fasteners (16" o.c.)	0.35" (9) Ø	347 (50)	-	489 (7830)	0.12 (500)
11	2x10 Rim Joist	1 1/2" (38)	0.69 (0.10)	-	31 (510)	0.45 (1880)
12	Steel Flashing	18 Gauge	430 (62)	-	489 (7830)	0.12 (500)
13	Wood Strapping (1" x 3")	3/4" (19)	0.69 (0.10)	-	31 (500)	0.45 (1880)
14	Rainscreen Cavity	3/4" (19)	-	R-0.4 (0.07 RSI)	0.075 (1.2)	0.24 (1000)
15	Fiber Cement Board	1/2" (13)	4.86 (0.7)	-	-	-
16	Foundation Wall Concrete	8" (203)	12.5 (1.8)	-	140 (2250)	0.20 (850)
17	ICF Insulation (Inboard)	3 1/8" (79)	0.25 (0.036)	R-12.5 (2.20 RSI)	66 (1060)	0.35 (1500)
18	ICF Insulation (Outboard)	7 1/8" (181)	0.25 (0.036)	R-28.5 (5.02 RSI)	66 (1060)	0.35 (1500)
19	ICF HDPE Tie (12" o.c.)	15 1/2" (292)	1.7 (0.25)	-	59 (950)	0.48 (2000)
20	Cement Protection Board	1/2" (13)	1.7 (0.25)	R-0.3 (0.051 RSI)	72 (1150)	0.20 (850)
21	Soil	-	14 (2.0)	-	-	-
22	Exterior Film ^{1,2}	-	-	R-0.2 to R-0.7 (0.03 to 0.12 RSI)	-	-

¹ Value selected from table 1, p. 26.1 of 2009 ASHRAE Handbook – Fundamentals depending on surface orientation

² Except at foundation wall adjacent soil



Detail 8.6.10

Interior Insulated Double Framed Wall 2x6 and 2x4 Wood Stud (16" o.c.) Wall Assembly with 2" Gap and Partially Wrapped R-22.5 Raft Slab Insulation – Slab on Grade Foundation Intersection

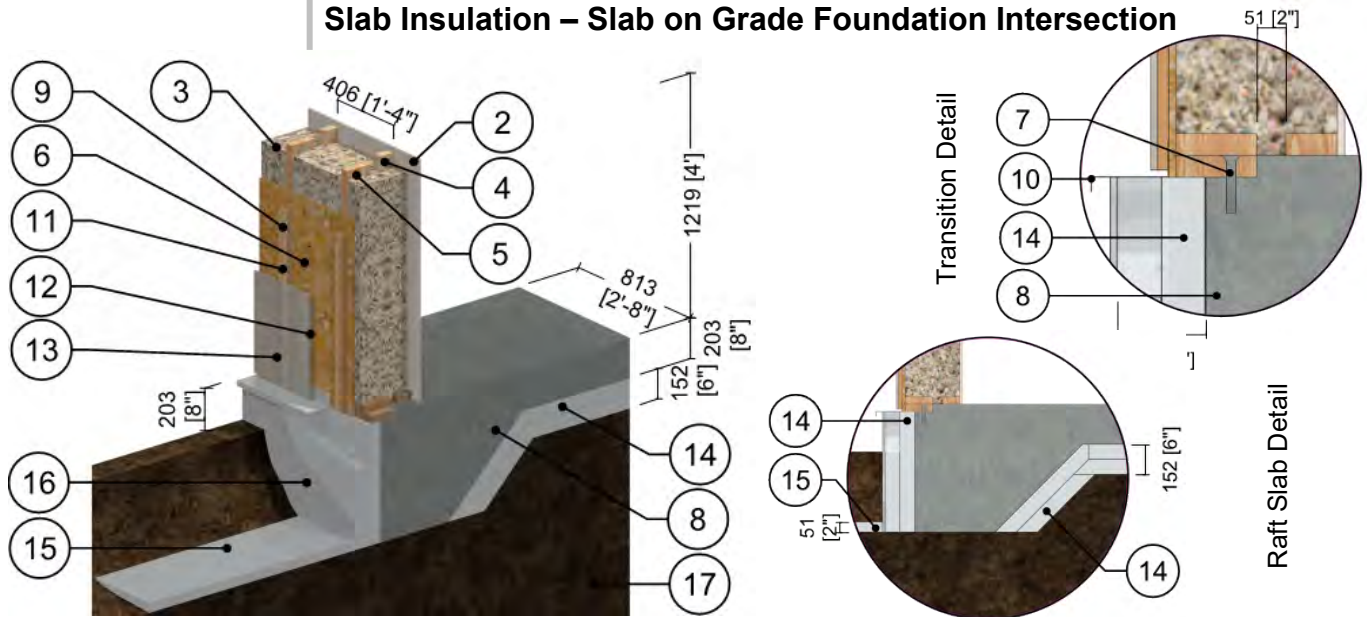

ID	Component	Thickness Inches (mm)	Conductivity Btu·in / ft ² ·hr·°F (W/m K)	Nominal Resistance hr·ft ² ·°F/Btu (m ² K/W)	Density lb/ft ³ (kg/m ³)	Specific Heat Btu/lb·°F (J/kg K)
1	Interior Film ¹	-	-	R-0.6 to R-0.9 (0.11 RSI to 0.16 RSI)	-	-
2	Gypsum Board	1/2" (13)	1.1 (0.16)	R-0.5 (0.08 RSI)	50 (800)	0.26 (1090)
3	Fill Insulation	11" (279)	Varies	-	-	-
4	2x4 Wood Stud (16" o.c.)	3 1/2" (89)	0.69 (0.10)	-	31 (500)	0.45 (1880)
5	2x6 Wood Stud (16" o.c.)	5 1/2" (140)	0.69 (0.10)	-	31 (500)	0.45 (1880)
6	Exterior Plywood Sheathing	1/2" (13)	0.69 (0.10)	R-0.7 (0.13 RSI)	31 (500)	0.45 (1880)
7	Stainless Steel Foundation Bolt	1/2" (13) Ø	118 (17)	-	500 (8000)	0.12 (500)
8	Concrete Slab on Grade	8" (203)	12.5 (1.8)	-	140 (2250)	0.20 (850)
9	Steel Fasteners (16" o.c.)	0.35" (9) Ø	347 (50)	-	489 (7830)	0.12 (500)
10	Steel Flashing	18 Gauge	430 (62)	-	489 (7830)	0.12 (500)
11	Wood Strapping (1" x 3")	3/4" (19)	0.69 (0.10)	-	31 (500)	0.45 (1880)
12	Rainscreen Cavity	3/4" (19)	-	R-0.4 (0.07 RSI)	0.075 (1.2)	0.24 (1000)
13	Fiber Cement Board	1/2" (13)	4.86 (0.7)	-	-	-
14	Slab Insulation	6" (152)	0.27 (0.038)	R-22.5 (3.96 RSI)	1 (16)	0.35 (1470)
15	Skirt Insulation	2" (51)	0.27 (0.038)	R-7.5 (1.32 RSI)	1 (16)	0.35 (1470)
16	Cement Protection Board	1/2" (13)	1.7 (0.25)	R-0.3 (0.051 RSI)	72 (1150)	0.20 (850)
17	Soil	-	14 (2.0)	-	-	-
18	Exterior Film ^{1,2}	-	-	R-0.2 to R-0.7 (0.03 to 0.12 RSI)	-	-

¹ Value selected from table 1, p. 26.1 of 2009 ASHRAE Handbook – Fundamentals depending on surface orientation

² Except at foundation wall adjacent soil

Detail 8.6.11

Interior Insulated Double Framed Wall 2x6 and 2x4 Wood Stud (16" o.c.) Wall Assembly with 2" Gap and Partially Wrapped R-45 Raft Slab Insulation – Slab on Grade Foundation Intersection

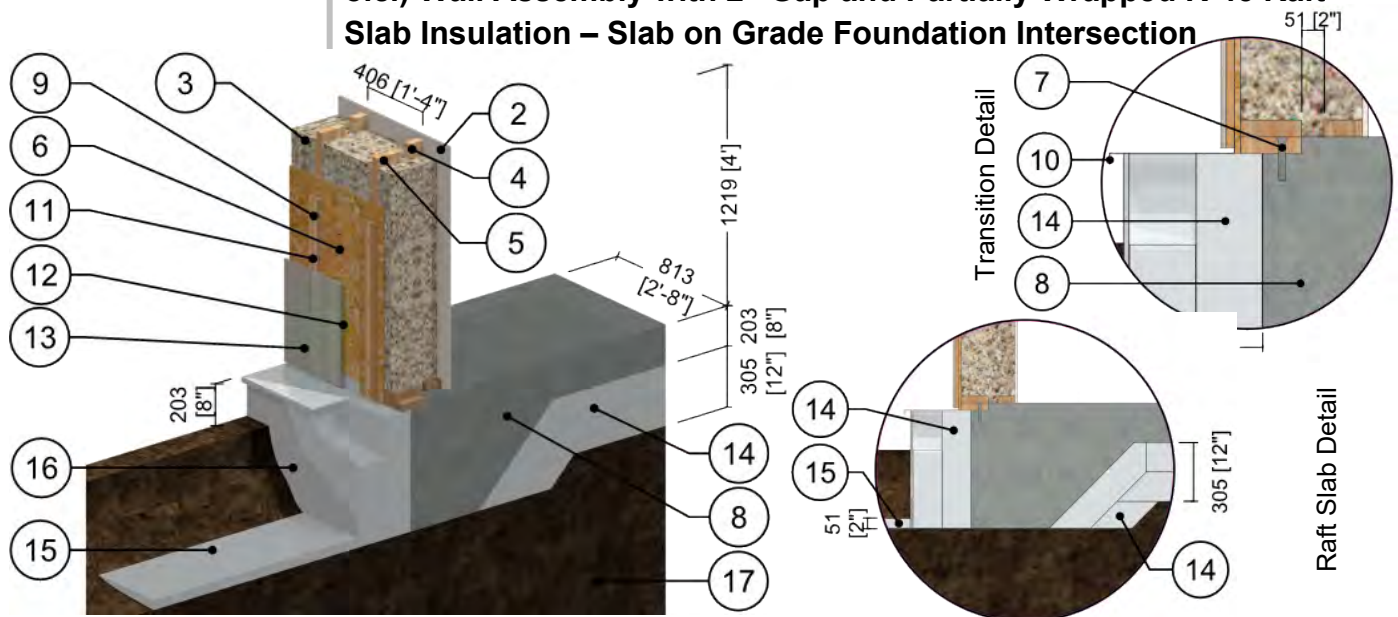

ID	Component	Thickness Inches (mm)	Conductivity Btu-in / ft ² ·hr·°F (W/m K)	Nominal Resistance hr·ft ² ·°F/Btu (m ² K/W)	Density lb/ft ³ (kg/m ³)	Specific Heat Btu/lb·°F (J/kg K)
1	Interior Film ¹	-	-	R-0.6 to R-0.9 (0.11 RSI to 0.16 RSI)	-	-
2	Gypsum Board	1/2" (13)	1.1 (0.16)	R-0.5 (0.08 RSI)	50 (800)	0.26 (1090)
3	Fill Insulation	11" (279)	Varies	-	-	-
4	2x4 Wood Stud (16" o.c.)	3 1/2" (89)	0.69 (0.10)	-	31 (500)	0.45 (1880)
5	2x6 Wood Stud (16" o.c.)	5 1/2" (140)	0.69 (0.10)	-	31 (500)	0.45 (1880)
6	Exterior Plywood Sheathing	1/2" (13)	0.69 (0.10)	R-0.7 (0.13 RSI)	31 (500)	0.45 (1880)
7	Stainless Steel Foundation Bolt	1/2" (13) Ø	118 (17)	-	500 (8000)	0.12 (500)
8	Concrete Slab on Grade	8" (203)	12.5 (1.8)	-	140 (2250)	0.20 (850)
9	Steel Fasteners (16" o.c.)	0.35" (9) Ø	347 (50)	-	489 (7830)	0.12 (500)
10	Steel Flashing	18 Gauge	430 (62)	-	489 (7830)	0.12 (500)
11	Wood Strapping (1" x 3")	3/4" (19)	0.69 (0.10)	-	31 (500)	0.45 (1880)
12	Rainscreen Cavity	3/4" (19)	-	R-0.4 (0.07 RSI)	0.075 (1.2)	0.24 (1000)
13	Fiber Cement Board	1/2" (13)	4.86 (0.7)	-	-	-
14	Slab Insulation	12" (305)	0.27 (0.038)	R-45 (7.93 RSI)	1 (16)	0.35 (1470)
15	Skirt Insulation	2" (51)	0.27 (0.038)	R-7.5 (1.32 RSI)	1 (16)	0.35 (1470)
16	Cement Protection Board	1/2" (13)	1.7 (0.25)	R-0.3 (0.051 RSI)	72 (1150)	0.20 (850)
17	Soil	-	14 (2.0)	-	-	-
18	Exterior Film ^{1,2}	-	-	R-0.2 to R-0.7 (0.03 to 0.12 RSI)	-	-

¹ Value selected from table 1, p. 26.1 of 2009 ASHRAE Handbook – Fundamentals depending on surface orientation

² Except at foundation wall adjacent soil



Detail 8.6.12 Interior Insulated Double Framed Wall 2x6 and 2x4 Wood Stud (16" o.c.) Wall Assembly with 2" Gap and Fully Wrapped R-22.5 Raft Slab Insulation – Slab on Grade Foundation Intersection

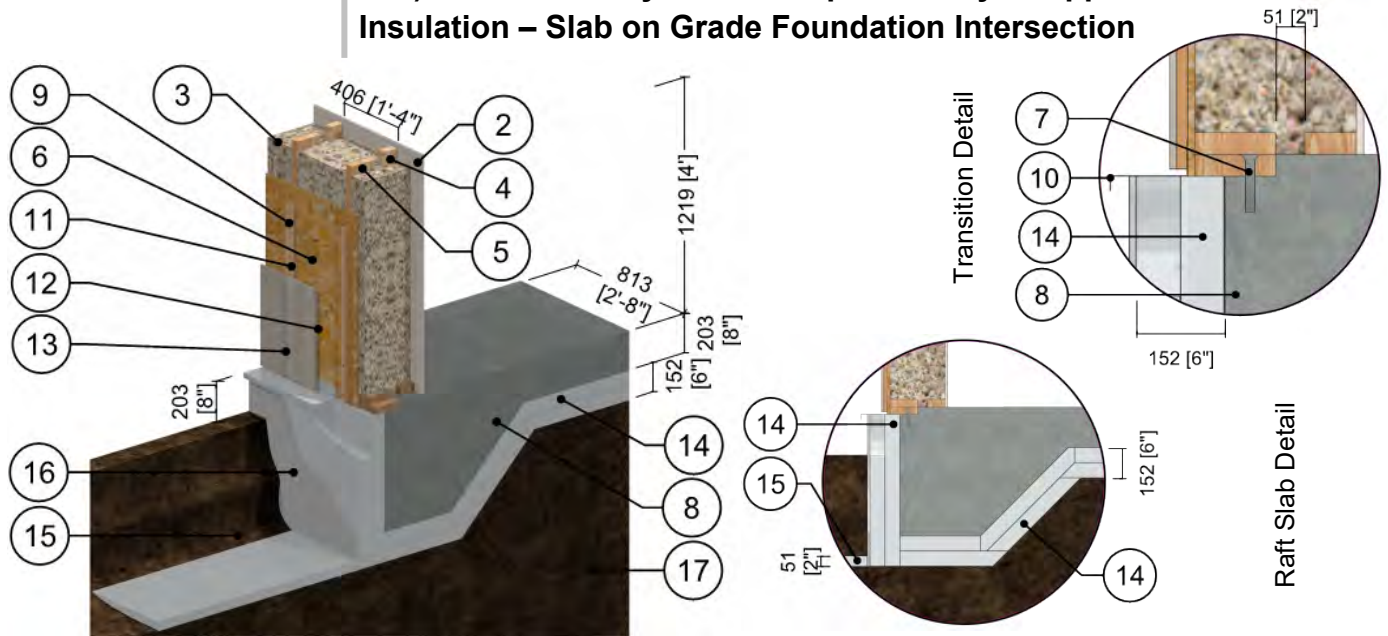

ID	Component	Thickness Inches (mm)	Conductivity Btu-in / ft ² ·hr·°F (W/m K)	Nominal Resistance hr·ft ² ·°F/Btu (m ² K/W)	Density lb/ft ³ (kg/m ³)	Specific Heat Btu/lb·°F (J/kg K)
1	Interior Film ¹	-	-	R-0.6 to R-0.9 (0.11 RSI to 0.16 RSI)	-	-
2	Gypsum Board	1/2" (13)	1.1 (0.16)	R-0.5 (0.08 RSI)	50 (800)	0.26 (1090)
3	Fill Insulation	11" (279)	Varies	-	-	-
4	2x4 Wood Stud (16" o.c.)	3 1/2" (89)	0.69 (0.10)	-	31 (500)	0.45 (1880)
5	2x6 Wood Stud (16" o.c.)	5 1/2" (140)	0.69 (0.10)	-	31 (500)	0.45 (1880)
6	Exterior Plywood Sheathing	1/2" (13)	0.69 (0.10)	R-0.7 (0.13 RSI)	31 (500)	0.45 (1880)
7	Stainless Steel Foundation Bolt	1/2" (13) Ø	118 (17)	-	500 (8000)	0.12 (500)
8	Concrete Slab on Grade	8" (203)	12.5 (1.8)	-	140 (2250)	0.20 (850)
9	Steel Fasteners (16" o.c.)	0.35" (9) Ø	347 (50)	-	489 (7830)	0.12 (500)
10	Steel Flashing	18 Gauge	430 (62)	-	489 (7830)	0.12 (500)
11	Wood Strapping (1" x 3")	3/4" (19)	0.69 (0.10)	-	31 (500)	0.45 (1880)
12	Rainscreen Cavity	3/4" (19)	-	R-0.4 (0.07 RSI)	0.075 (1.2)	0.24 (1000)
13	Fiber Cement Board	1/2" (13)	4.86 (0.7)	-	-	-
14	Slab Insulation	6" (152)	0.27 (0.038)	R-22.5 (3.96 RSI)	1 (16)	0.35 (1470)
15	Skirt Insulation	2" (51)	0.27 (0.038)	R-7.5 (1.32 RSI)	1 (16)	0.35 (1470)
16	Cement Protection Board	1/2" (13)	1.7 (0.25)	R-0.3 (0.051 RSI)	72 (1150)	0.20 (850)
17	Soil	-	14 (2.0)	-	-	-
18	Exterior Film ^{1,2}	-	-	R-0.2 to R-0.7 (0.03 to 0.12 RSI)	-	-

¹ Value selected from table 1, p. 26.1 of 2009 ASHRAE Handbook – Fundamentals depending on surface orientation

² Except at foundation wall adjacent soil

Detail 8.6.13

Interior Insulated Double Framed Wall 2x6 and 2x4 Wood Stud (16" o.c.) Wall Assembly with 2" Gap and Fully Wrapped R-45 Raft Slab Insulation – Slab on Grade Foundation Intersection

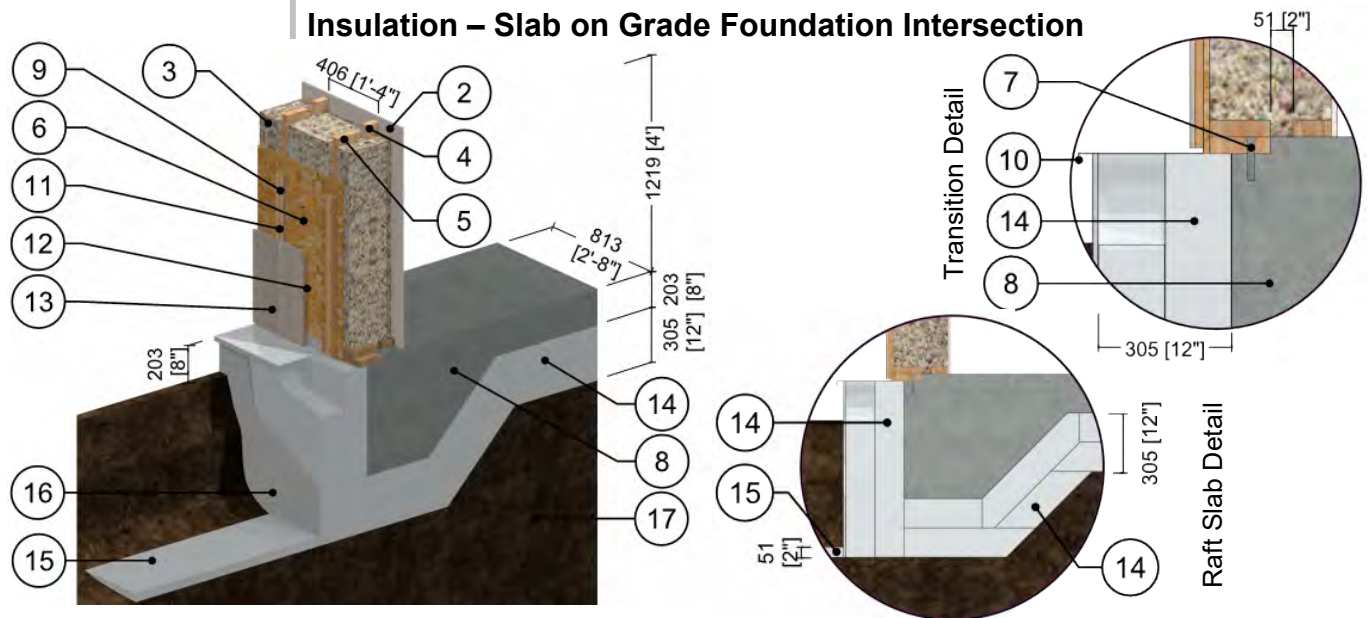

ID	Component	Thickness Inches (mm)	Conductivity Btu-in / ft ² ·hr·°F (W/m K)	Nominal Resistance hr·ft ² ·°F/Btu (m ² K/W)	Density lb/ft ³ (kg/m ³)	Specific Heat Btu/lb·°F (J/kg K)
1	Interior Film ¹	-	-	R-0.6 to R-0.9 (0.11 RSI to 0.16 RSI)	-	-
2	Gypsum Board	1/2" (13)	1.1 (0.16)	R-0.5 (0.08 RSI)	50 (800)	0.26 (1090)
3	Fill Insulation	11" (279)	Varies	-	-	-
4	2x4 Wood Stud (16" o.c.)	3 1/2" (89)	0.69 (0.10)	-	31 (500)	0.45 (1880)
5	2x6 Wood Stud (16" o.c.)	5 1/2" (140)	0.69 (0.10)	-	31 (500)	0.45 (1880)
6	Exterior Plywood Sheathing	1/2" (13)	0.69 (0.10)	R-0.7 (0.13 RSI)	31 (500)	0.45 (1880)
7	Stainless Steel Foundation Bolt	1/2" (13) Ø	118 (17)	-	500 (8000)	0.12 (500)
8	Concrete Slab on Grade	8" (203)	12.5 (1.8)	-	140 (2250)	0.20 (850)
9	Steel Fasteners (16" o.c.)	0.35" (9) Ø	347 (50)	-	489 (7830)	0.12 (500)
10	Steel Flashing	18 Gauge	430 (62)	-	489 (7830)	0.12 (500)
11	Wood Strapping (1" x 3")	3/4" (19)	0.69 (0.10)	-	31 (500)	0.45 (1880)
12	Rainscreen Cavity	3/4" (19)	-	R-0.4 (0.07 RSI)	0.075 (1.2)	0.24 (1000)
13	Fiber Cement Board	1/2" (13)	4.86 (0.7)	-	-	-
14	Slab Insulation	12" (305)	0.27 (0.038)	R-45 (7.93 RSI)	1 (16)	0.35 (1470)
15	Skirt Insulation	2" (51)	0.27 (0.038)	R-7.5 (1.32 RSI)	1 (16)	0.35 (1470)
16	Cement Protection Board	1/2" (13)	1.7 (0.25)	R-0.3 (0.051 RSI)	72 (1150)	0.20 (850)
17	Soil	-	14 (2.0)	-	-	-
18	Exterior Film ^{1,2}	-	-	R-0.2 to R-0.7 (0.03 to 0.12 RSI)	-	-

¹ Value selected from table 1, p. 26.1 of 2009 ASHRAE Handbook – Fundamentals depending on surface orientation

² Except at foundation wall adjacent soil

Detail 8.6.14 Interior Insulated Double Framed Wall 2x6 and 2x4 Wood Stud (16" o.c.) Wall Assembly with 2" Gap and R-22.5 Slab Insulation with Gravel Base – Slab on Grade Foundation Intersection

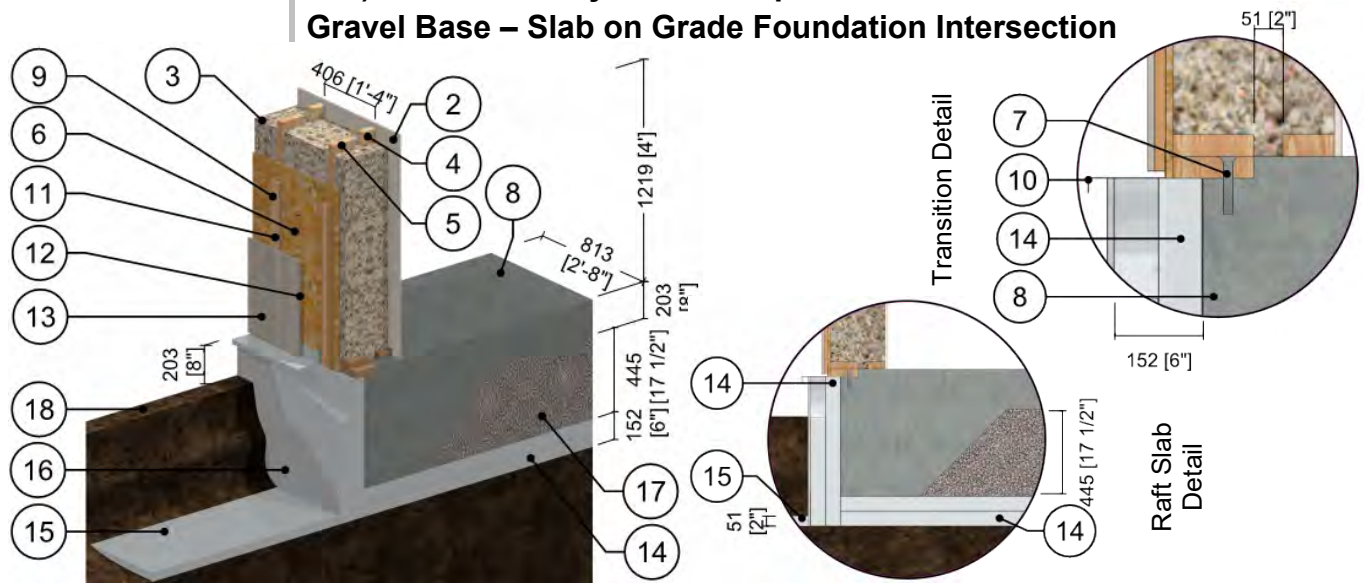

ID	Component	Thickness Inches (mm)	Conductivity Btu-in / ft ² -hr-°F (W/m K)	Nominal Resistance hr-ft ² -°F/Btu (m ² K/W)	Density lb/ft ³ (kg/m ³)	Specific Heat Btu/lb-°F (J/kg K)
1	Interior Film ¹	-	-	R-0.6 to R-0.9 (0.11 RSI to 0.16 RSI)	-	-
2	Gypsum Board	1/2" (13)	1.1 (0.16)	R-0.5 (0.08 RSI)	50 (800)	0.26 (1090)
3	Fill Insulation	11" (279)	Varies	-	-	-
4	2x4 Wood Stud (16" o.c.)	3 1/2" (89)	0.69 (0.10)	-	31 (500)	0.45 (1880)
5	2x6 Wood Stud (16" o.c.)	5 1/2" (140)	0.69 (0.10)	-	31 (500)	0.45 (1880)
6	Exterior Plywood Sheathing	1/2" (13)	0.69 (0.10)	R-0.7 (0.13 RSI)	31 (500)	0.45 (1880)
7	Stainless Steel Foundation Bolt	1/2" (13) Ø	118 (17)	-	500 (8000)	0.12 (500)
8	Concrete Slab on Grade	8" (203)	12.5 (1.8)	-	140 (2250)	0.20 (850)
9	Steel Fasteners (16" o.c.)	0.35" (9) Ø	347 (50)	-	489 (7830)	0.12 (500)
10	Steel Flashing	18 Gauge	430 (62)	-	489 (7830)	0.12 (500)
11	Wood Strapping (1" x 3")	3/4" (19)	0.69 (0.10)	-	31 (500)	0.45 (1880)
12	Rainscreen Cavity	3/4" (19)	-	R-0.4 (0.07 RSI)	0.075 (1.2)	0.24 (1000)
13	Fiber Cement Board	1/2" (13)	4.86 (0.7)	-	-	-
14	Slab Insulation	6" (152)	0.27 (0.038)	R-22.5 (3.96 RSI)	1 (16)	0.35 (1470)
15	Skirt Insulation	2" (51)	0.27 (0.038)	R-7.5 (1.32 RSI)	1 (16)	0.35 (1470)
16	Cement Protection Board	1/2" (13)	1.7 (0.25)	R-0.3 (0.051 RSI)	72 (1150)	0.20 (850)
17	Sand/Gravel	-	14 (2.0)	-	-	-
18	Soil	-	14 (2.0)	-	-	-
19	Exterior Film ^{1,2}	-	-	R-0.2 to R-0.7 (0.03 to 0.12 RSI)	-	-

¹ Value selected from table 1, p. 26.1 of 2009 ASHRAE Handbook – Fundamentals depending on surface orientation

² Except at foundation wall adjacent soil

Detail 8.6.15

Interior Insulated Double Framed Wall 2x6 and 2x4 Wood Stud (16" o.c.) Wall Assembly with 2" Gap and R-45 Slab Insulation with Gravel Base – Slab on Grade Foundation Intersection

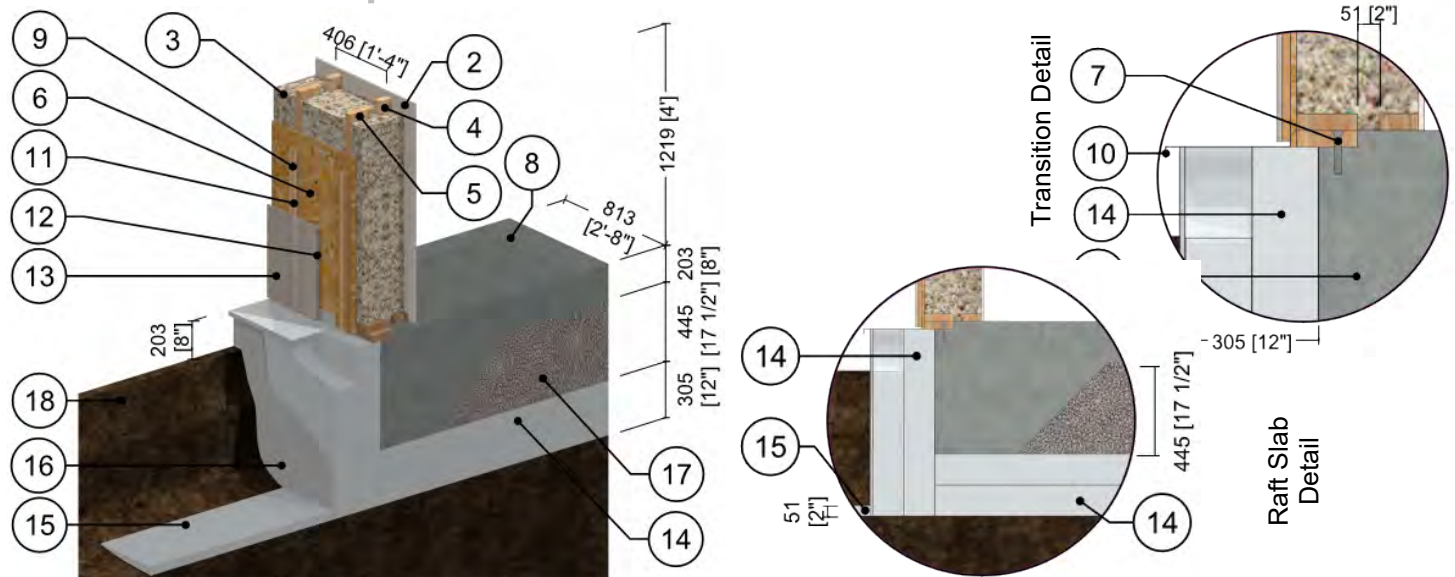

ID	Component	Thickness Inches (mm)	Conductivity Btu-in / ft ² -hr-°F (W/m K)	Nominal Resistance hr-ft ² -°F/Btu (m ² K/W)	Density lb/ft ³ (kg/m ³)	Specific Heat Btu/lb-°F (J/kg K)
1	Interior Film ¹	-	-	R-0.6 to R-0.9 (0.11 RSI to 0.16 RSI)	-	-
2	Gypsum Board	1/2" (13)	1.1 (0.16)	R-0.5 (0.08 RSI)	50 (800)	0.26 (1090)
3	Fill Insulation	11" (279)	Varies	-	-	-
4	2x4 Wood Stud (16" o.c.)	3 1/2" (89)	0.69 (0.10)	-	31 (500)	0.45 (1880)
5	2x6 Wood Stud (16" o.c.)	5 1/2" (140)	0.69 (0.10)	-	31 (500)	0.45 (1880)
6	Exterior Plywood Sheathing	1/2" (13)	0.69 (0.10)	R-0.7 (0.13 RSI)	31 (500)	0.45 (1880)
7	Stainless Steel Foundation Bolt	1/2" (13) Ø	118 (17)	-	500 (8000)	0.12 (500)
8	Concrete Slab on Grade	8" (203)	12.5 (1.8)	-	140 (2250)	0.20 (850)
9	Steel Fasteners (16" o.c.)	0.35" (9) Ø	347 (50)	-	489 (7830)	0.12 (500)
10	Steel Flashing	18 Gauge	430 (62)	-	489 (7830)	0.12 (500)
11	Wood Strapping (1" x 3")	3/4" (19)	0.69 (0.10)	-	31 (500)	0.45 (1880)
12	Rainscreen Cavity	3/4" (19)	-	R-0.4 (0.07 RSI)	0.075 (1.2)	0.24 (1000)
13	Fiber Cement Board	1/2" (13)	4.86 (0.7)	-	-	-
14	Slab Insulation	12" (305)	0.27 (0.038)	R-45 (7.93 RSI)	1 (16)	0.35 (1470)
15	Skirt Insulation	2" (51)	0.27 (0.038)	R-7.5 (1.32 RSI)	1 (16)	0.35 (1470)
16	Cement Protection Board	1/2" (13)	1.7 (0.25)	R-0.3 (0.051 RSI)	72 (1150)	0.20 (850)
17	Sand/Gravel	-	14 (2.0)	-	-	-
18	Soil	-	14 (2.0)	-	-	-
19	Exterior Film ^{1,2}	-	-	R-0.2 to R-0.7 (0.03 to 0.12 RSI)	-	-

¹ Value selected from table 1, p. 26.1 of 2009 ASHRAE Handbook – Fundamentals depending on surface orientation

² Except at foundation wall adjacent soil

Detail 8.7.1

Exterior and Interior Insulated Wood Infill Wall Assembly with Wood Strapping and Continuous Insulation Supporting Fiber Cement Board and R-19 Batt Insulation in Stud Cavity – Concrete Wall and Intermediate Floor Intersection with Flashing Bypassing Exterior Insulation

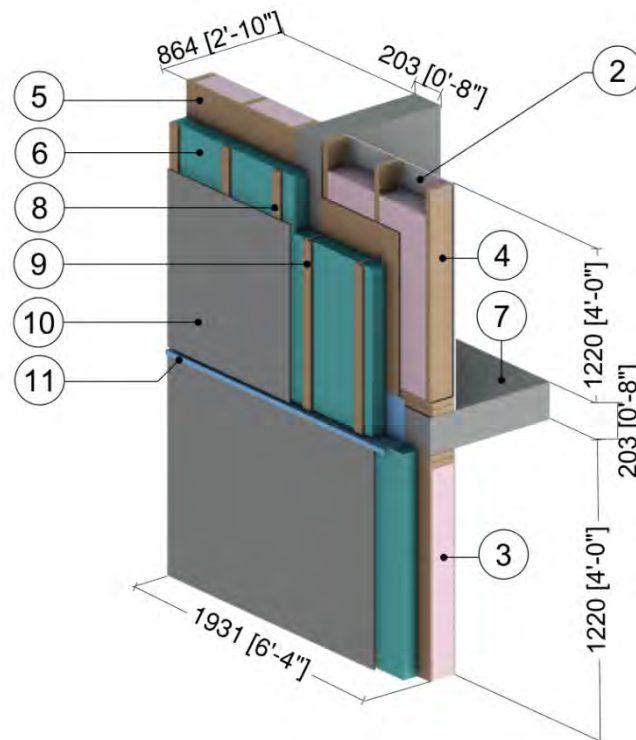

ID	Component	Thickness Inches (mm)	Conductivity Btu·in / ft ² ·hr·°F (W/m K)	Nominal Resistance hr·ft ² ·°F/Btu (m ² K/W)	Density lb/ft ³ (kg/m ³)	Specific Heat Btu/lb·°F (J/kg K)
1	Interior Film ¹	-	-	R-0.6 to R-0.9 (0.11 RSI to 0.16 RSI)	-	-
2	Gypsum Board	1/2" (13)	1.1 (0.16)	R-0.5 (0.08 RSI)	50 (800)	0.26 (1090)
3	Fiberglass Batt Insulation	5 1/2" (140)	0.29 (0.042)	R-19 (3.3 RSI)	0.9 (14)	0.17 (710)
4	2x6 Wood Stud (16" o.c.)	5 1/2" (140)	0.69 (0.10)	-	31 (500)	0.45 (1880)
5	Exterior Wood Sheathing	1/2" (13)	0.69 (0.10)	R-0.7 (0.12 RSI)	31 (500)	0.45 (1880)
6	Exterior Insulation	Varies	-	R-5 to R-15 (0.88 RSI to 2.64 RSI)	1.8 (28)	0.29 (1220)
7	Concrete Wall & Floor Slab	8" (203)	12.5 (1.8)	-	140 (2250)	0.20 (850)
8	1x3 Wood Strapping	3/4" (19)	0.69 (0.10)	-	31 (500)	0.45 (1880)
9	Steel Fasteners (16" o.c.)	0.35" (9) Ø	347(50)	-	489 (7830)	0.12 (500)
10	Fiber Cement Board Cladding with 3/4" (19mm) vented airspace incorporated into exterior heat transfer coefficient					
11	Steel Flashing	18 Gauge	430 (62)	-	489 (7830)	0.12 (500)
12	Exterior Film ¹	-	-	R-0.7 (0.12 RSI)	-	-

¹ Value selected from table 1, p. 26.1 of 2009 ASHRAE Handbook – Fundamentals depending on surface orientation

Detail 8.7.2

Exterior Insulated Cross Laminated Timber (CLT) Wall Assembly with Wood Strapping and Continuous Rigid Insulation Supporting Fiber Cement Board – Cross Laminated Timber Floor Intersection with Flashing Bypassing Exterior Insulation

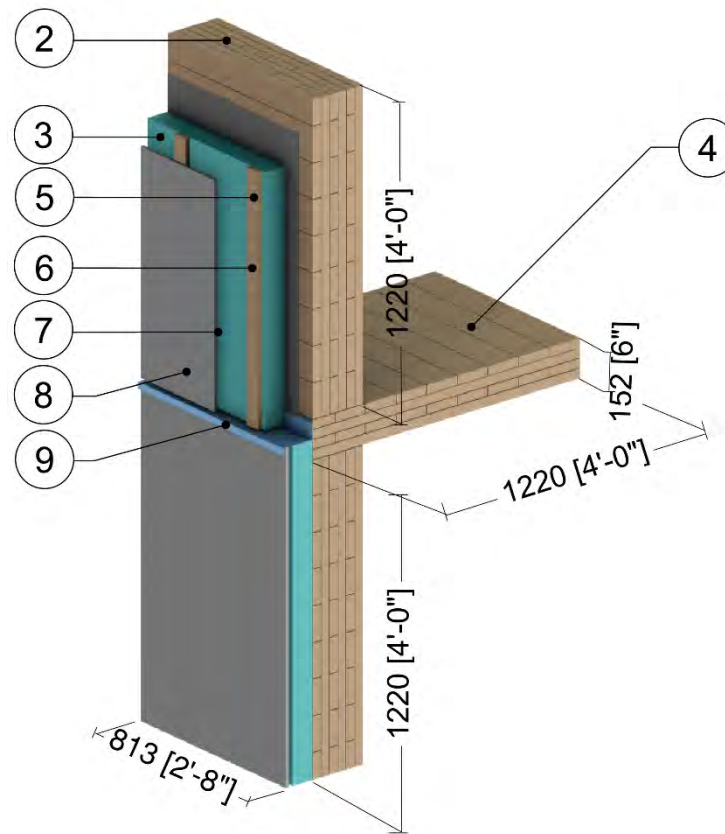

ID	Component	Thickness Inches (mm)	Conductivity Btu-in / ft ² ·hr·°F (W/m K)	Nominal Resistance hr·ft ² ·°F/Btu (m ² K/W)	Density lb/ft ³ (kg/m ³)	Specific Heat Btu/lb·°F (J/kg K)
1	Interior Film ¹	-	-	R-0.6 to R-0.9 (0.11 RSI to 0.16 RSI)	-	-
2	Cross Laminated Timber Wall	7 1/2" (191)	0.83 (0.12)	R-9 (1.59 RSI)	31 (500)	0.45 (1880)
3	Exterior Insulation	Varies	-	R-15 to R-25 (2.64 RSI to 4.4 RSI)	1.8 (28)	0.29 (1220)
4	Cross Laminated Timber Floor	4 1/2" (114)	0.83 (0.12)	R-5.4 (0.95 RSI)	31 (500)	0.45 (1880)
5	1x3 Wood Strapping (16" o.c.)	3/4" (19)	0.69 (0.10)	-	31 (500)	0.45 (1880)
6	Steel Fasteners (12" o.c.)	0.44" (11) Ø	347 (50)	-	489 (7830)	0.12 (500)
7	Rainscreen Cavity	3/4" (19)	-	R-0.5 (0.09 RSI)	0.075 (1.2)	0.24 (1000)
8	Fiber Cement Board Cladding	1/2" (13)	4.9 (0.7)	R-0.1 (0.02 RSI)	112 (1800)	0.20 (840)
9	Steel Flashing	18 Gauge	430 (62)	-	489 (7830)	0.12 (500)
10	Galvanized Steel L-clips	3/8" (9.5)	430 (62)	-	489 (7830)	0.12 (500)
11	Exterior Film ¹	-	-	R-0.2 (0.03 RSI)	-	-

¹ Value selected from table 1, p. 26.1 of 2009 ASHRAE Handbook – Fundamentals depending on surface orientation

Detail 8.7.3

Exterior and Interior Insulated 2x6 Wood Stud (16" o.c.) Wall Assembly with Wood Strapping and Continuous Insulation Supporting Fiber Cement Board and R-19 Batt Insulation in Stud Cavity – One-Hour Fire Wall Intersection

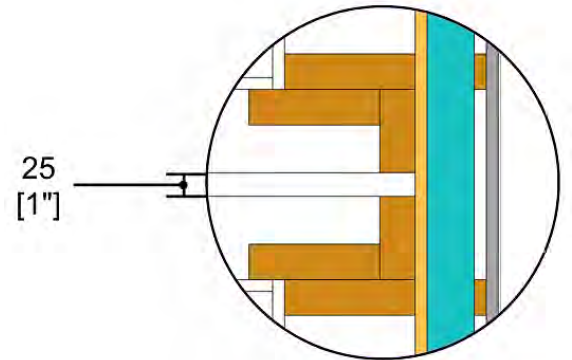
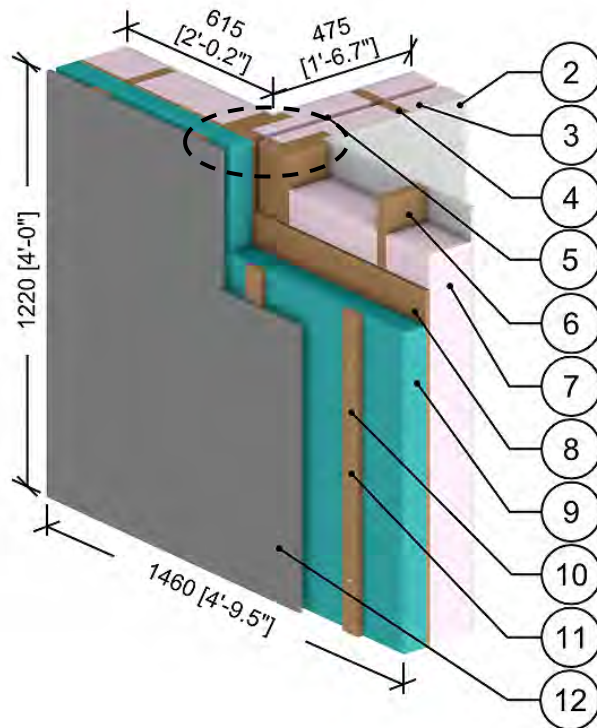

Fire Wall and Exterior Wall Intersection Detail

ID	Component	Thickness Inches (mm)	Conductivity Btu-in / ft ² -hr-°F (W/m K)	Nominal Resistance hr-ft ² -°F/Btu (m ² K/W)	Density lb/ft ³ (kg/m ³)	Specific Heat Btu/lb-°F (J/kg K)
1	Interior Film ¹	-	-	R-0.7 (0.12 RSI)	-	-
2	Gypsum Board	1/2" (13)	1.1 (0.16)	R-0.5 (0.08 RSI)	50 (800)	0.26 (1090)
3	Fiberglass Batt Insulation in 2x4 Stud Cavity	3 1/2" (89)	0.29 (0.042)	R-12 (2.11 RSI)	0.9 (14)	0.17 (710)
4	2x4 Wood Stud (16" o.c.)	3 1/2" (89)	0.69 (0.10)	-	31 (500)	0.45 (1880)
5	Air Gap	1" (25)	-	R-0.9 (0.16 RSI)	0.075 (1.2)	0.24 (1000)
6	Fiberglass Batt Insulation in 2x6 Stud Cavity	5 1/2" (140)	0.29 (0.042)	R-19 (3.3 RSI)	0.9 (14)	0.17 (710)
7	2x6 Wood Stud (16" o.c.)	5 1/2" (140)	0.69 (0.10)	-	31 (500)	0.45 (1880)
8	Exterior Plywood Sheathing	1/2" (13)	0.69 (0.10)	R-0.7 (0.13 RSI)	31 (500)	0.45 (1880)
9	Exterior Insulation	Varies	-	R-5 to R-15 (0.88 RSI to 2.64 RSI)	1.8 (28)	0.29 (1220)
10	Wood Strapping (1" x 3")	3/4" (19)	0.69 (0.10)	-	31 (500)	0.45 (1880)
11	Steel Fasteners (12" o.c.)	0.43" (11) Ø	347 (50)	-	489 (7830)	0.12 (500)
12	Fiber Cement Board Cladding with 3/4" (19mm) vented airspace incorporated into exterior heat transfer coefficient					
13	Exterior Film ¹	-	-	R-0.7 (0.12 RSI)	-	-

¹ Value selected from table 1, p. 26.1 of 2009 ASHRAE Handbook – Fundamentals depending on surface orientation



9.0 Doors and Balconies

Detail 9.1.1	A.9.1
Interior Insulated Concrete Curb at Sliding Door Sill and Window Head – Intermediate Floor Intersection	
Detail 9.1.2	A.9.2
Exterior Insulated Concrete Curb at Sliding Door Sill and Window Head – Intermediate Floor Intersection	
Detail 9.1.3	A.9.3
Interior Insulated Concrete Curb – Window-Wall and Intermediate Floor Intersection	
Detail 9.1.4	A.9.4
Exterior Insulated Concrete Curb at Sliding Door Sill and Head- Intermediate Floor Intersection	
Detail 9.1.5	A.9.5
Exterior Insulated Concrete Curb – Window-Wall and Recessed Intermediate Floor Intersection	
Detail 9.1.6	A.9.6
Window Wall System with Spandrel Panels and Sliding Door - Concrete Balcony and Curb Intersection	
Detail 9.1.7	A.9.7
Window-wall with Sliding Door and Insulated Spandrel Section – Concrete Intermediate Floor Intersection without Concrete Curb for Alternative Balcony Slab Connections	
Detail 9.1.8	A.9.8
Window Wall System with Spandrel Panels and Sliding Door - Thermally Broken Concrete Balcony and Curb Intersection	
Detail 9.1.9	A.9.9
Window Wall System with Spandrel Panels - Concrete Balcony and Bypass Intersection	
Detail 9.1.10	A.9.10
Interior Insulated 3 5/8" x 1 5/8" Steel Stud (16" o.c.) Wall Assembly - Door Sill with Exterior Slab Insulation	
Detail 9.1.11	A.9.11
Exterior and Interior Insulated 3 5/8" x 1 5/8" Steel Stud (16" o.c.) Wall Assembly - Door Sill with Exterior Slab Insulation	
Detail 9.1.12	A.9.12
Window Wall System with Spandrel Panels and Sliding Door - Schöck Isokorb K65-V8 Thermal Break at Concrete Balcony and Curb Intersection	
Detail 9.1.13	A.9.13

Window Wall System with Spandrel Panels and Sliding Door - Schöck Isokorb K10-V6 Thermal Break at Concrete Balcony and Curb Intersection	
Detail 9.1.14	A.9.14
Window Wall System with Spandrel Panels and Sliding Door - Schöck Isokorb KXT65-V8 Thermal Break at Concrete Balcony and Curb Intersection	
Detail 9.1.15	A.9.15
Window Wall System with Spandrel Panels and Sliding Door - Schöck Isokorb KXT15-V6 Thermal Break at Concrete Balcony and Curb Intersection	
Detail 9.1.16	A.9.16
Exterior Insulated 2"x6" Steel Stud (16" o.c.) Wall Assembly with FRP Vertical Brackets and Rail System Supporting Metal Cladding and Sliding Door – Intermittently Attached Balcony and Sliding Door Intersection	
Detail 9.1.17	A.9.17
Exterior and Interior Insulated 2"x6" Steel Stud (16" o.c.) Wall Assembly with FRP Vertical Brackets and Rail System Supporting Metal Cladding with R-19 Batt in Stud Cavity and Sliding Door – Intermittently Attached Balcony and Sliding Door Intersection	
Detail 9.1.18	A.9.18
Exterior Insulated 2" x 6" Steel Stud (16" o.c.) Wall Assembly with Vertical Clips (24" o.c.) Supporting Cladding and Sliding Door – Concrete Balcony and Curb Intersection	
Detail 9.1.19	A.9.19
Exterior and Interior Insulated 2" x 6" Steel Stud (16" o.c.) Wall Assembly with Vertical Clips (24" o.c.) Supporting Cladding with R-19 Batt in Stud Cavity and Sliding Door – Concrete Balcony and Curb Intersection	
Detail 9.1.20	A.9.20
Exterior Insulated 2" x 6" Steel Stud (16" o.c.) Wall Assembly with Vertical Clips (24" o.c.) Supporting Cladding and Sliding Door – Structural Thermal Break at Concrete Balcony and Curb Intersection	
Detail 9.1.21	A.9.21
Exterior and Interior Insulated 2" x 6" Steel Stud (16" o.c.) Wall Assembly with Vertical Clips (24" o.c.) Supporting Cladding with R-19 Batt in Stud Cavity and Sliding Door – Structural Thermal Break at Concrete Balcony and Curb Intersection	

Detail 9.1.1

Interior Insulated Concrete Curb at Sliding Door Sill and Window Head – Intermediate Floor Intersection

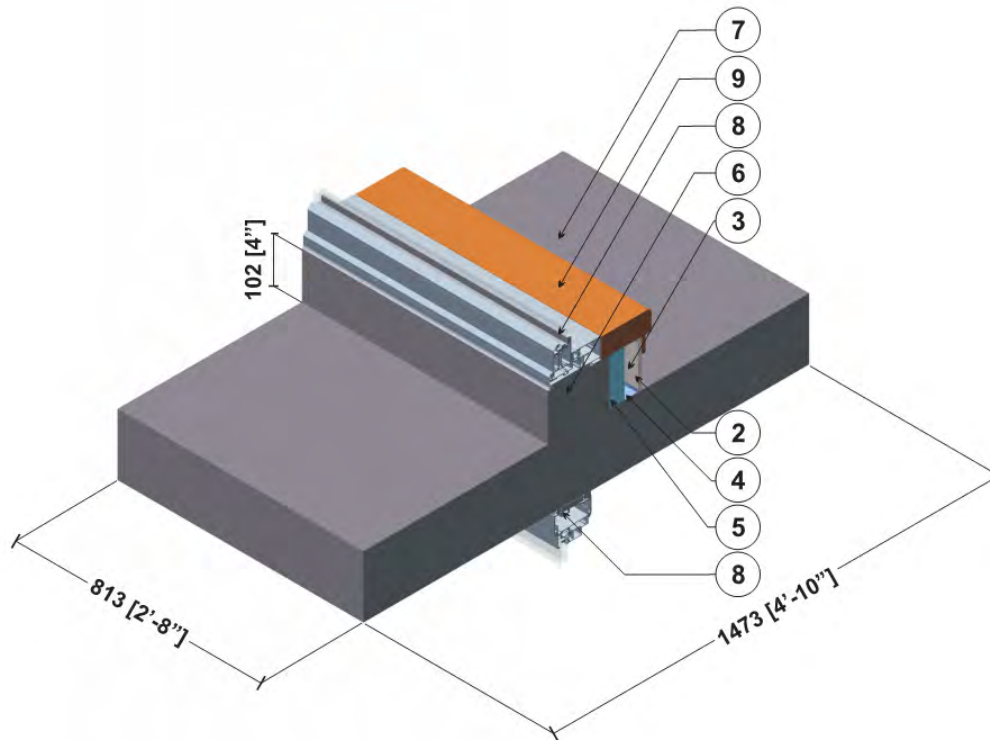

ID	Component	Thickness Inches (mm)	Conductivity Btu-in / ft ² ·hr·°F (W/m K)	Nominal Resistance hr·ft ² ·°F/Btu (m ² K/W)	Density lb/ft ³ (kg/m ³)	Specific Heat Btu/lb·°F (J/kg K)
1	Interior Film ¹	-	-	R-0.6 to R-0.9 (0.11 RSI to 0.16 RSI)	-	-
2	Gypsum Board	1/2" (13)	1.1 (0.16)	R-0.5 (0.08 RSI)	50 (800)	0.26 (1090)
3	Air in Stud Cavity	2 5/8" (67)	-	R-0.9 (0.16 RSI)	0.075 (1.2)	0.24 (1000)
4	2 5/8" x 1 5/8" Steel Studs with Top and Bottom Tracks	18 Gauge	430 (62)	-	489 (7830)	0.12 (500)
5	Interior Insulation	2" (50)	-	R-10 (1.8 RSI)	1.8 (28)	0.29 (1220)
6	Concrete Curb	6" (152)	12.5 (1.8)	-	140 (2250)	0.20 (850)
7	Concrete Slab	8" (203)	12.5 (1.8)	-	140 (2250)	0.20 (850)
8	Thermally Broken Aluminum Window & Sliding Door ²					
9	Wood Sill	2" (50)	0.63 (0.09)	-	1.8 (28)	0.29 (1220)
10	Exterior Film ¹	-	-	R-0.2 (0.03 RSI)	-	-

¹ Value selected from table 1, p. 26.1 of 2009 ASHRAE Handbook – Fundamentals depending on surface orientation

² The thermal conductivity of air spaces within sliding door and window framing was found using ISO 10077-2.

Detail 9.1.2

Exterior Insulated Concrete Curb at Sliding Door Sill and Window Head – Intermediate Floor Intersection

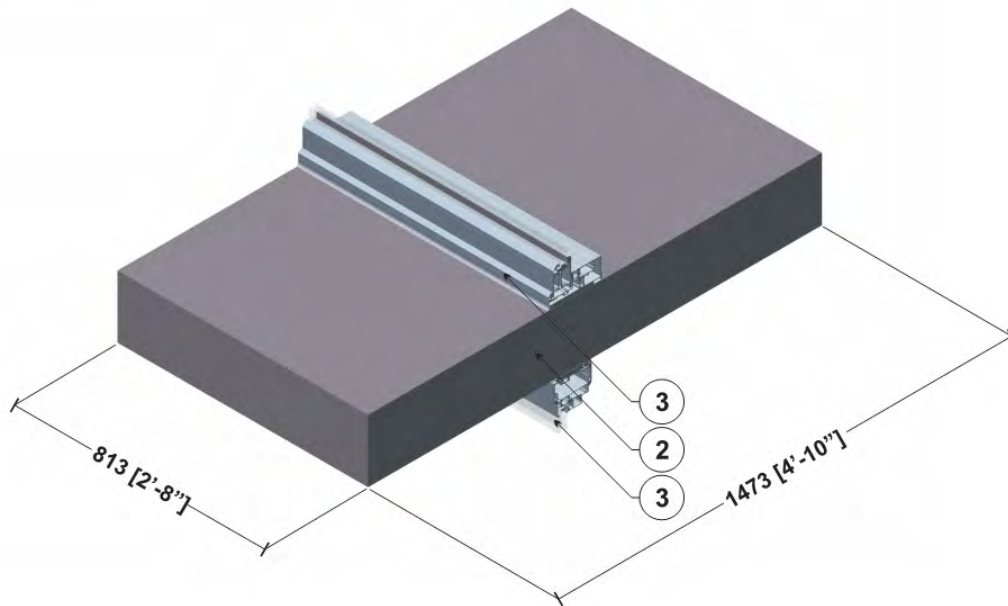

ID	Component	Thickness Inches (mm)	Conductivity Btu-in / ft ² ·hr·°F (W/m K)	Nominal Resistance hr·ft ² ·°F/Btu (m ² K/W)	Density lb/ft ³ (kg/m ³)	Specific Heat Btu/lb·°F (J/kg K)
1	Interior Film ¹	-	-	R-0.6 to R-0.9 (0.11 RSI to 0.16 RSI)	-	-
2	Concrete Slab	8" (203)	12.5 (1.8)	-	140 (2250)	0.20 (850)
3	Thermally Broken Aluminum Window & Sliding Door ²					
4	Exterior Film ¹	-	-	R-0.2 (0.03 RSI)	-	-

¹ Value selected from table 1, p. 26.1 of 2009 ASHRAE Handbook – Fundamentals depending on surface orientation

² The thermal conductivity of air spaces within sliding door and window framing was found using ISO 10077-2.

Detail 9.1.3

Interior Insulated Concrete Curb – Window-Wall and Intermediate Floor Intersection

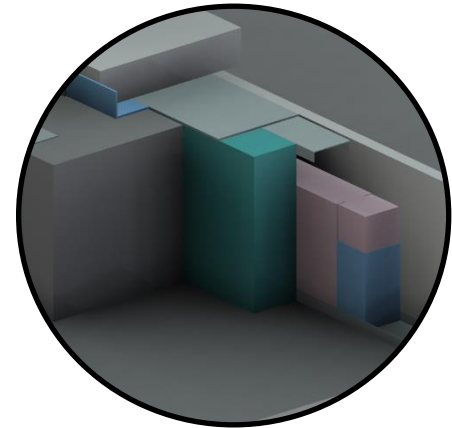
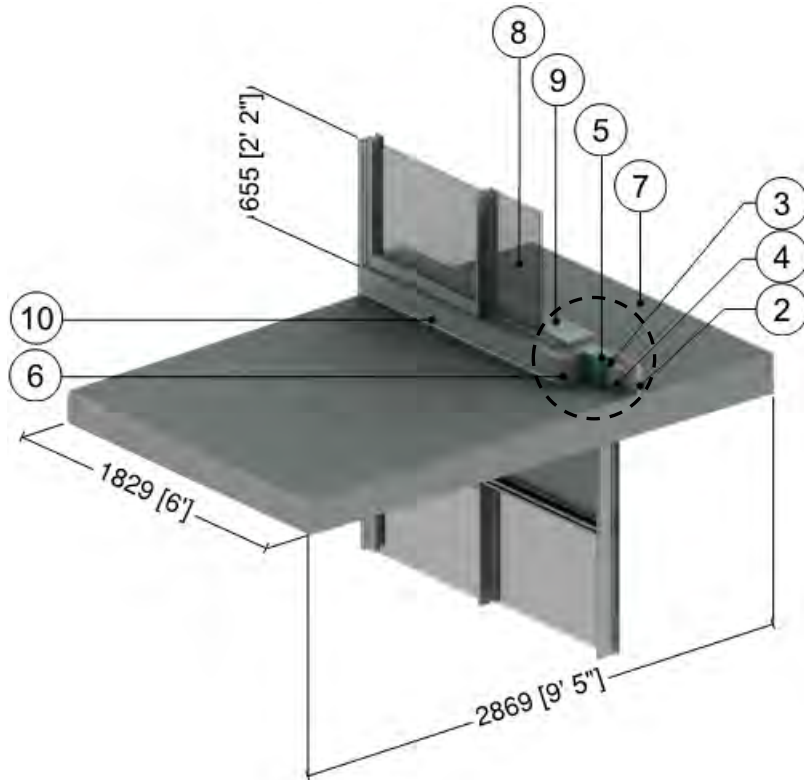

Curb Detail

ID	Component	Thickness Inches (mm)	Conductivity Btu-in / ft ² ·hr·°F (W/m K)	Nominal Resistance hr·ft ² ·°F/Btu (m ² K/W)	Density lb/ft ³ (kg/m ³)	Specific Heat Btu/lb·°F (J/kg K)
1	Interior Films ¹	-	-	R-0.6 to R-0.9 (0.11 RSI to 0.16 RSI)	-	-
2	Gypsum Board	1/2" (13)	1.1 (0.16)	R-0.5 (0.08 RSI)	50 (800)	0.26 (1090)
3	Fiberglass Batt Insulation	1 5/8" (41)	0.29 (0.042)	R-5.5 (0.98 RSI)	0.9 (14)	0.17 (710)
4	1 5/8" x 1 5/8" Steel Studs with Top and Bottom Tracks	18 Gauge	430 (62)	-	489 (7830)	0.12 (500)
5	Continuous Rigid Insulation	2" (51)	0.24 (0.034)	R-10 (1.76 RSI)	1.8 (28)	0.29 (1220)
6	Concrete Curb	6" (152)	12.5 (1.8)	-	140 (2250)	0.20 (850)
7	Concrete Slab	8" (203)	12.5 (1.8)	-	140 (2250)	0.20 (850)
8	Thermally Broken Aluminum Sliding Door ² , double glazed IGU U _{IGU} = 0.32 BTU/hr·ft ² ·°F (1.82 W/m ² K)					
9	Wood Sill	2" (50)	0.69 (0.10)	-	31 (500)	0.45 (1880)
10	Steel Flashing	16 Gauge	430 (62)	-	489 (7830)	0.12 (500)
11	Exterior Film ¹	-	-	R-0.2 to R-0.7 (0.03 RSI to 0.12 RSI)	-	-

¹ Value selected from table 1, p. 26.1 of 2009 ASHRAE Handbook – Fundamentals depending on surface orientation

² The thermal conductivity of air spaces within sliding door framing was found using ISO 10077-2

Detail 9.1.4

Exterior Insulated Concrete Curb at Sliding Door Sill and Head-Intermediate Floor Intersection

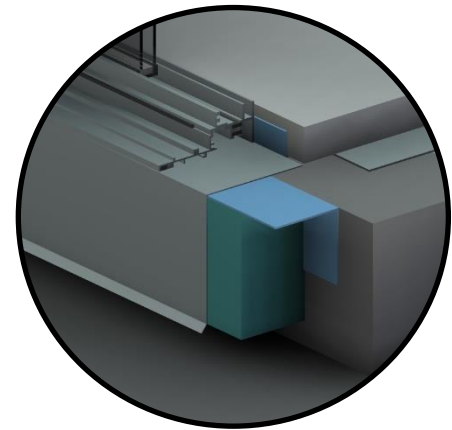
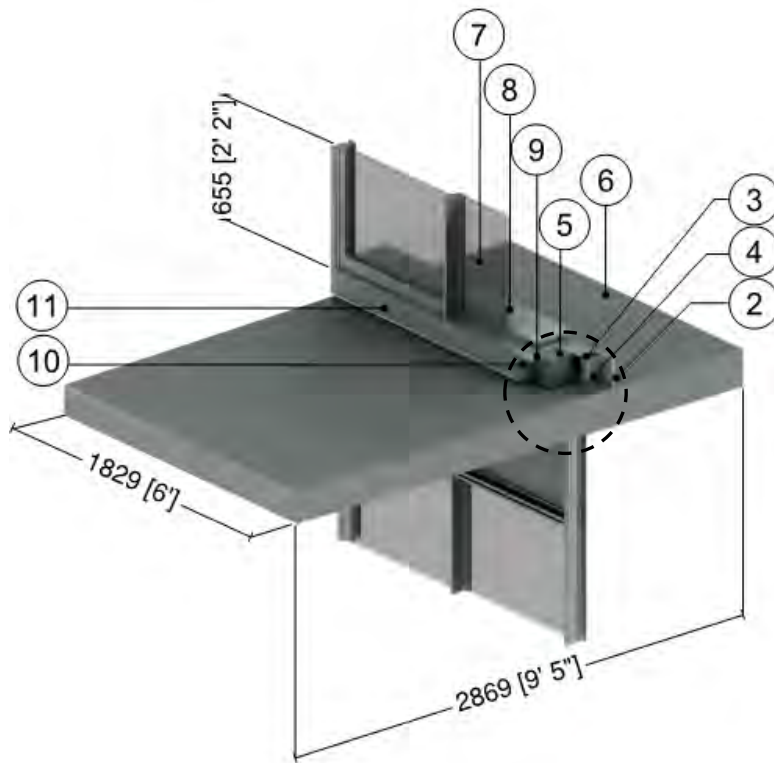

Curb Detail

ID	Component	Thickness Inches (mm)	Conductivity Btu-in / ft ² ·hr·°F (W/m K)	Nominal Resistance hr·ft ² ·°F/Btu (m ² K/W)	Density lb/ft ³ (kg/m ³)	Specific Heat Btu/lb·°F (J/kg K)
1	Interior Films ¹	-	-	R-0.6 to R-0.9 (0.11 RSI to 0.16 RSI)	-	-
2	Gypsum Board	1/2" (13)	1.1 (0.16)	R-0.5 (0.08 RSI)	50 (800)	0.26 (1090)
3	Air In Stud Cavity	3 5/8" (92)	-	R-0.9 (0.16 RSI)	0.075 (1.2)	0.24 (1000)
4	1 5/8" x 1 5/8" Steel Studs with Top and Bottom Tracks	18 Gauge	430 (62)	-	489 (7830)	0.12 (500)
5	Concrete Curb	6" (152)	12.5 (1.8)	-	140 (2250)	0.20 (850)
6	Concrete Slab	8" (203)	12.5 (1.8)	-	140 (2250)	0.20 (850)
7	Thermally Broken Aluminum Sliding Door ² , double glazed IGU U _{IGU} = 0.32 BTU/hr·ft ² ·°F (1.82 W/m ² K)					
8	Wood Sill	2" (50)	0.69 (0.1)	-	31 (500)	0.45 (1880)
9	Support Angle	3/8" (10)	347 (50)	-	489 (7830)	0.12 (500)
10	Exterior Insulation	Varies	-	R-10 to R-15 (1.76 RSI to 2.64 RSI)	1.8 (28)	0.29 (1220)
11	Steel Flashing	16 Gauge	430 (62)	-	489 (7830)	0.12 (500)
12	Exterior Film ¹	-	-	R-0.2 to R-0.7 (0.03 RSI to 0.12 RSI)	-	-

¹ Value selected from table 1, p. 26.1 of 2009 ASHRAE Handbook – Fundamentals depending on surface orientation

² The thermal conductivity of air spaces within sliding door framing was found using ISO 10077-2

Detail 9.1.5

Exterior Insulated Concrete Curb – Window-Wall and Recessed Intermediate Floor Intersection

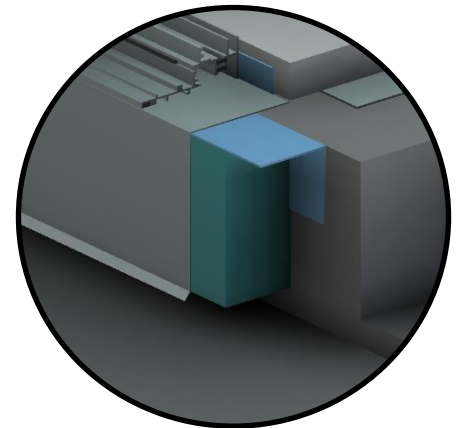
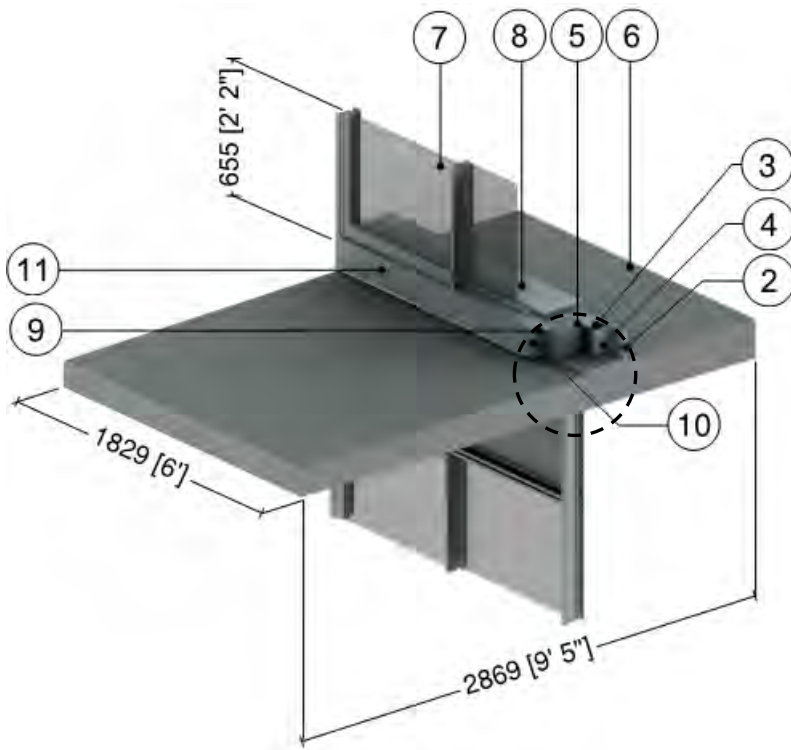

Curb Detail

ID	Component	Thickness Inches (mm)	Conductivity Btu-in / ft ² ·hr·°F (W/m K)	Nominal Resistance hr·ft ² ·°F/Btu (m ² K/W)	Density lb/ft ³ (kg/m ³)	Specific Heat Btu/lb·°F (J/kg K)
1	Interior Films ¹	-	-	R-0.6 to R-0.9 (0.11 RSI to 0.16 RSI)	-	-
2	Gypsum Board	1/2" (13)	1.1 (0.16)	R-0.5 (0.08 RSI)	50 (800)	0.26 (1090)
3	Air In Stud Cavity	3 5/8" (92)	-	R-0.9 (0.16 RSI)	0.075 (1.2)	0.24 (1000)
4	1 5/8" x 1 5/8" Steel Studs with Top and Bottom Tracks	18 Gauge	430 (62)	-	489 (7830)	0.12 (500)
5	Concrete Curb	6" (152)	12.5 (1.8)	-	140 (2250)	0.20 (850)
6	Concrete Slab	8" (203)	12.5 (1.8)	-	140 (2250)	0.20 (850)
7	Thermally Broken Aluminum Sliding Door ² , double glazed IGU U _{IGU} = 0.32 BTU/hr·ft ² ·°F (1.82 W/m ² K)					
8	Wood Sill	2" (50)	0.69 (0.10)	-	31 (500)	0.45 (1880)
9	Support Angle	3/8" (10)	347 (50)	-	489 (7830)	0.12 (500)
10	Exterior Insulation	Varies	-	R-10 to R-15 (1.76 RSI to 2.64 RSI)	1.8 (28)	0.29 (1220)
11	Steel Flashing	16 Gauge	430 (62)	-	489 (7830)	0.12 (500)
12	Exterior Film ¹	-	-	R-0.2 to R-0.7 (0.03 RSI to 0.12 RSI)	-	-

¹ Value selected from table 1, p. 26.1 of 2009 ASHRAE Handbook – Fundamentals depending on surface orientation

² The thermal conductivity of air spaces within sliding door framing was found using ISO 10077-2

Detail 9.1.6

Window Wall System with Spandrel Panels and Sliding Door - Concrete Balcony and Curb Intersection

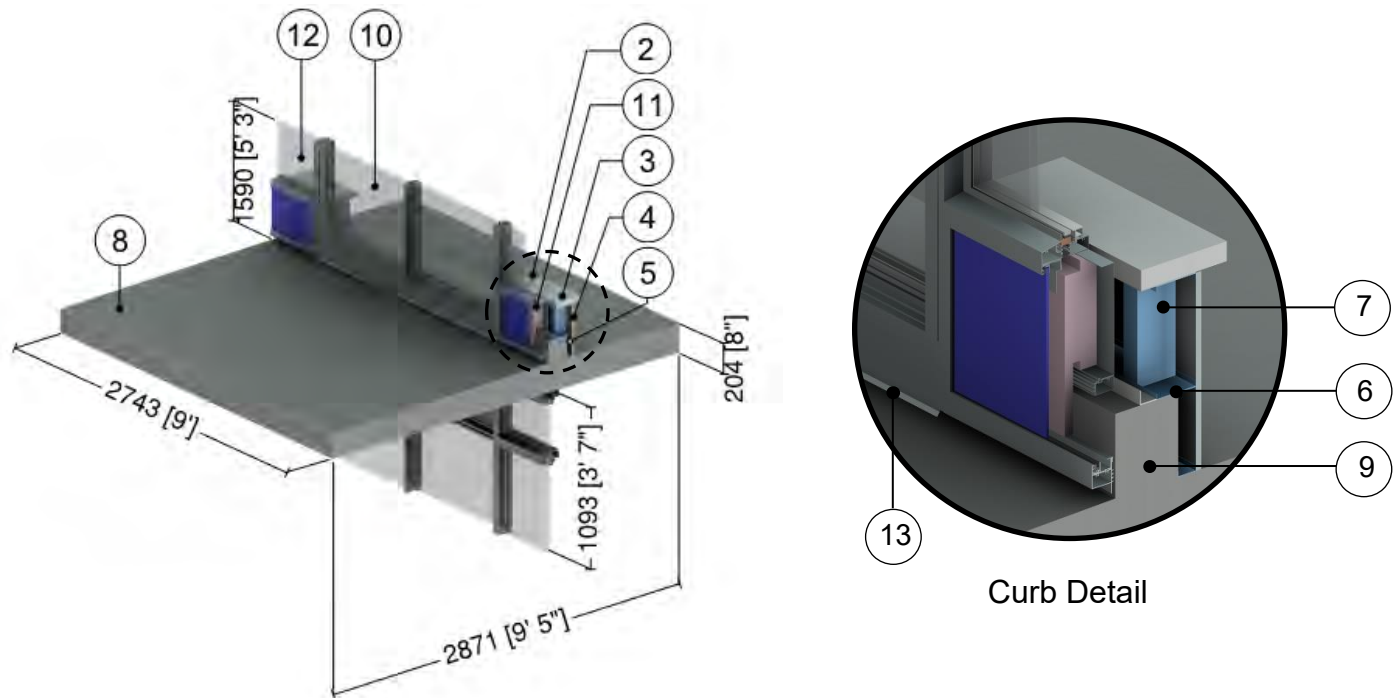

ID	Component	Thickness Inches (mm)	Conductivity Btu-in / ft ² ·hr·°F (W/m K)	Nominal Resistance hr·ft ² ·°F/Btu (m ² K/W)	Density lb/ft ³ (kg/m ³)	Specific Heat Btu/lb·°F (J/kg K)
1	Interior Film ¹	-	-	R-0.6 to R-1.1 (0.12 RSI to 0.20 RSI)	-	-
2	Wood Sill	2" (50)	0.69 (0.1)	-	31 (500)	0.45 (1880)
3	Steel Sheet Connected to Studs	18 Gauge	430 (62)	-	489 (7830)	0.12 (500)
4	Gypsum Board	1/2" (13)	1.1 (0.16)	R-0.5 (0.08 RSI)	50 (800)	0.26 (1090)
5	Air in Stud Cavity	1 5/8" (41)	-	R-0.9 (0.16 RSI)	0.075 (1.2)	0.24 (1000)
6	1 5/8" x 1 5/8" Steel Studs (16" o.c.) with Top and Bottom Tracks	18 Gauge	430 (62)	-	489 (7830)	0.12 (500)
7	3 5/8" x 1 5/8" Steel Studs (16" o.c.) with Top and Bottom Tracks	18 Gauge	430 (62)	-	489 (7830)	0.12 (500)
8	Concrete Slab	8" (203)	12.5 (1.8)	-	140 (2250)	0.20 (850)
9	Concrete Curb	6" (152)	12.5 (1.8)	-	140 (2250)	0.20 (850)
10	Thermally Broken Aluminum Sliding Door ² , double glazed IGU U _{IGU} = 0.32 BTU/hr·ft ² ·°F (1.82 W/m ² K)					
11	Back Pan Insulation	Varies	0.24 (0.034)	R-6.3 to R-12.6 (1.11 RSI to 2.22 RSI)	4 (64)	0.20 (850)
12	Aluminum Window Wall Vision System ² : thermally broken frame, double glazed IGU U _{IGU} = 0.32 BTU/hr·ft ² ·°F (1.82 W/m ² K)					
13	Aluminum Flashing	16 Gauge	1109 (160)	-	171 (2739)	0.21 (900)
14	Exterior Film ¹	-	-	R-0.2 (0.03 RSI)	-	-

¹ Value selected from table 1, p. 26.1 of 2009 ASHRAE Handbook – Fundamentals depending on surface orientation

² The thermal conductivity of air spaces within framing was found using ISO 100077-2

Detail 9.1.7

Window-wall with Sliding Door and Insulated Spandrel Section – Concrete Intermediate Floor Intersection without Concrete Curb for Alternative Balcony Slab Connections

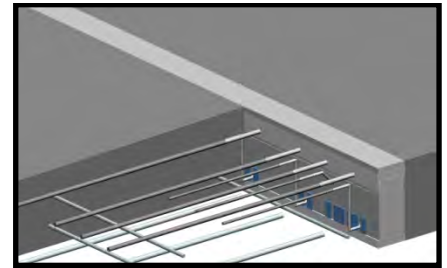
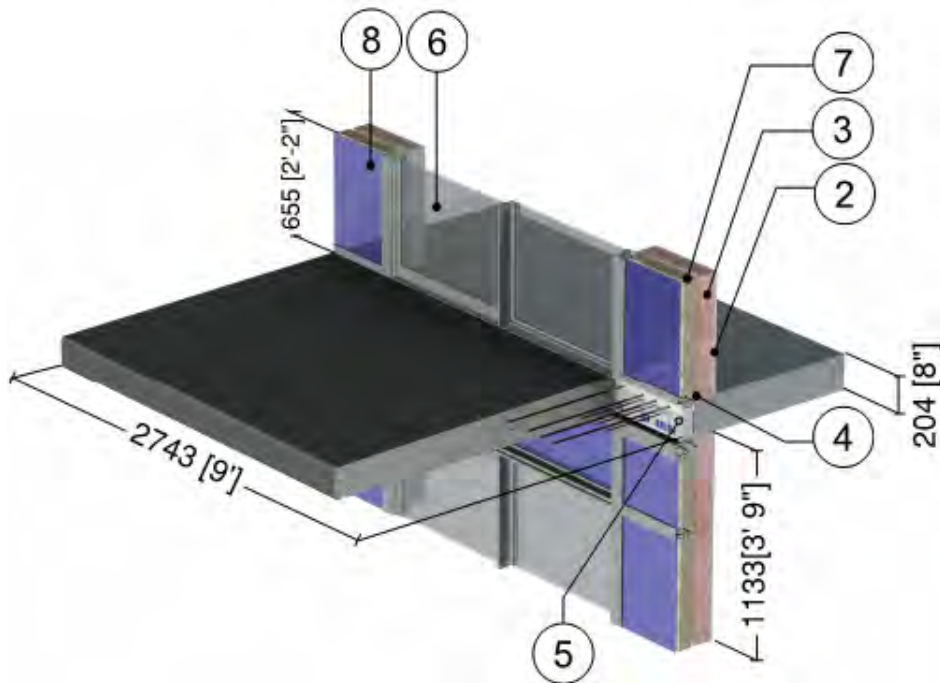

A – Thermally Broken Slab with 3" (80 mm) thick Isokorb CM20

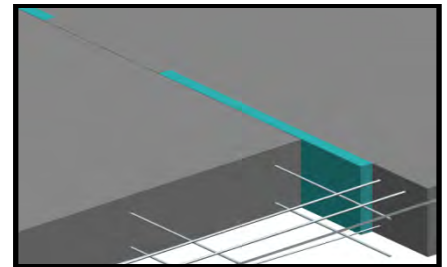

B – Thermally Broken Slab with 1.5" (40 mm) Intermittent Slab Insulation

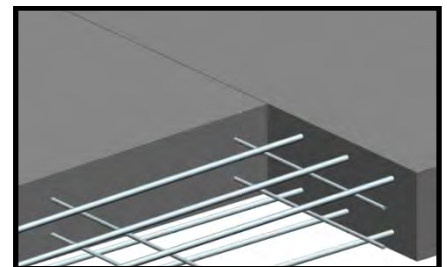

C – Continuous Slab

ID	Component	Thickness Inches (mm)	Conductivity Btu-in / ft ² ·hr·°F (W/m K)	Nominal Resistance hr·ft ² ·°F/Btu (m ² K/W)	Density lb/ft ³ (kg/m ³)	Specific Heat Btu/lb·°F (J/kg K)
1	Interior Film ¹	-	-	R-0.6 to R-1.1 (0.12 RSI to 0.20 RSI)	-	-
2	Gypsum Board	1/2" (13)	1.1 (0.16)	R-0.5 (0.08 RSI)	50 (800)	0.26 (1090)
3	Fiberglass Batt Insulation	3 5/8" (92)	0.29 (0.042)	R-12.4 (2.2 RSI)	0.9 (14)	0.17 (710)
4	3 5/8" x 1 5/8" Steel Studs (16" o.c.) with Top and Bottom Tracks	18 Gauge	430 (62)	-	489 (7830)	0.12 (500)
5	8" (203 mm) Concrete Slab with various slab balcony connections shown in A, B, or C above					
6	Thermally Broken Aluminum Sliding Door ² , double glazed IGU U _{IGU} = 0.32 BTU/hr·ft ² ·°F (1.82 W/m ² K)					
7	Back Pan Insulation	3" (75)	0.24 (0.034)	R-12.6 (2.2 RSI)	1.8 (28)	0.29 (1220)
8	Aluminum Window Wall Vision System: thermally broken frame, double glazed IGU, U _{IGU} = 0.32 BTU/hr·ft ² ·°F (1.82 W/m ² K) ²					
9	Exterior Film ¹	-	-	R-0.2 (0.03 RSI)	-	-

¹ Value selected from table 1, p. 26.1 of 2009 ASHRAE Handbook – Fundamentals depending on surface orientation

² The thermal conductivity of air spaces within framing was found using ISO 100077-2

Detail 9.1.8

Window Wall System with Spandrel Panels and Sliding Door - Thermally Broken Concrete Balcony and Curb Intersection

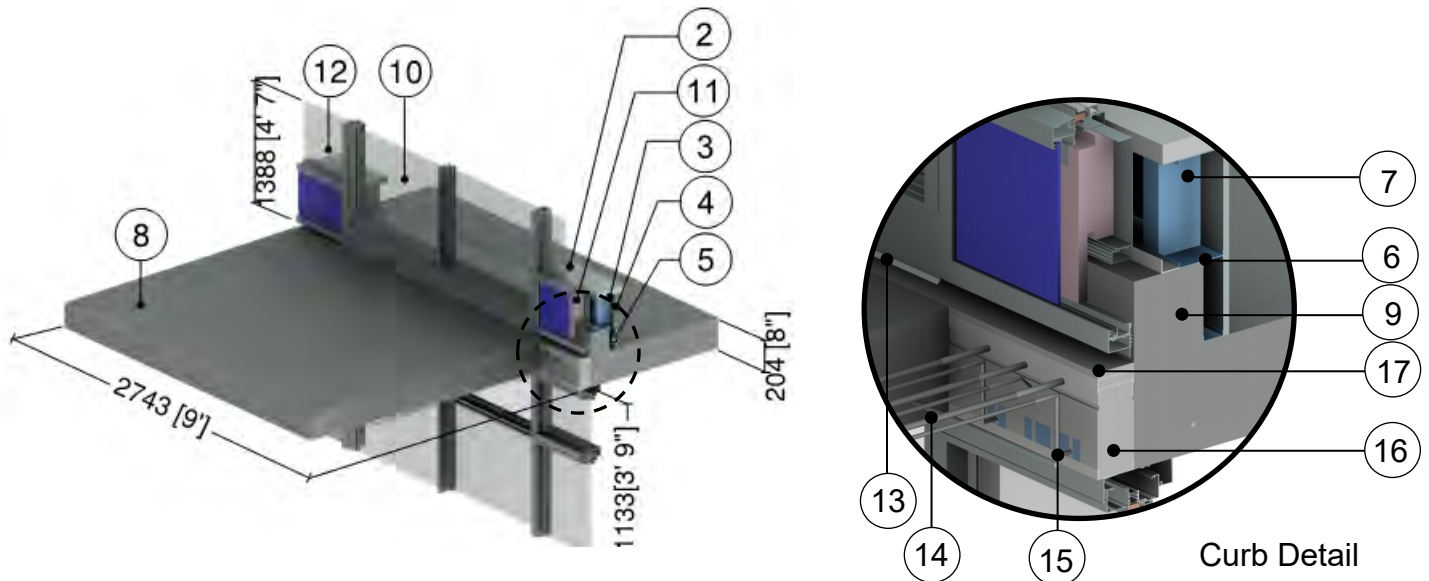

ID	Component	Thickness Inches (mm)	Conductivity Btu-in / ft ² ·hr·°F (W/m K)	Nominal Resistance hr·ft ² ·°F/Btu (m ² K/W)	Density lb/ft ³ (kg/m ³)	Specific Heat Btu/lb·°F (J/kg K)
1	Interior Film ¹	-	-	R-0.6 to R-1.1 (0.12 RSI to 0.20 RSI)	-	-
2	Wood Sill	2" (50)	0.69 (0.10)	-	31 (500)	0.45 (1880)
3	Steel Sheet Connected to Studs	18 Gauge	430 (62)	-	489 (7830)	0.12 (500)
4	Gypsum Board	1/2" (13)	1.1 (0.16)	R-0.5 (0.08 RSI)	50 (800)	0.26 (1090)
5	Air in Stud Cavity	Varies	-	R-0.9 (0.16 RSI)	0.075 (1.2)	0.24 (1000)
6	1 5/8" x 1 5/8" Steel Studs (16" o.c.) with Top and Bottom Tracks	18 Gauge	430 (62)	-	489 (7830)	0.12 (500)
7	3 5/8" x 1 5/8" Steel Studs (16" o.c.) with Top and Bottom Tracks	18 Gauge	430 (62)	-	489 (7830)	0.12 (500)
8	Concrete Slab	8" (203)	12.5 (1.8)	-	140 (2250)	0.20 (850)
9	Concrete Curb	6" (152)	12.5 (1.8)	-	140 (2250)	0.20 (850)
10	Thermally Broken Aluminum Sliding Door ² , double glazed IGU U _{IGU} = 0.32 BTU/hr·ft ² ·°F (1.82 W/m ² K)					
11	Back Pan Insulation	Varies	0.24 (0.034)	R-6.3 to R-12.6 (1.11 RSI to 2.22 RSI)	4 (64)	0.20 (850)
12	Aluminum Window Wall Vision System ² : thermally broken frame, double glazed IGU U _{IGU} = 0.32 BTU/hr·ft ² ·°F (1.82 W/m ² K)					
13	Aluminum Flashing	14 Gauge	1109 (160)	-	171 (2739)	0.21 (900)
14	Stainless Steel Rebar	-	118 (17)	-	500 (8000)	0.12 (500)
15	HDPE Plastic Sleeve	-	3.5 (0.5)	-	59 (950)	0.48 (2000)
16	Polystyrene Hard Foam Insulation	3" (76)	0.24 (0.035)	R-12 (2.1 RSI)	66 (1060)	0.35 (1500)
17	Cement Board	1" (25)	1.7 (0.25)	-	72 (1150)	0.20 (850)
18	Exterior Film ¹	-	-	R-0.2 (0.03 RSI)	-	-

¹ Value selected from table 1, p. 26.1 of 2009 ASHRAE Handbook – Fundamentals depending on surface orientation

² The thermal conductivity of air spaces within framing was found using ISO 100077-2

Detail 9.1.9

Window Wall System with Spandrel Panels - Concrete Balcony and Bypass Intersection

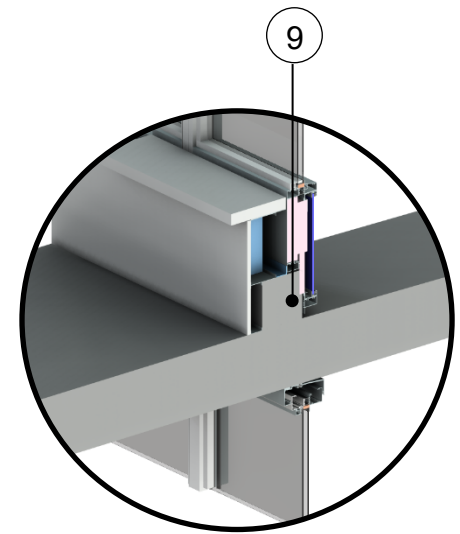
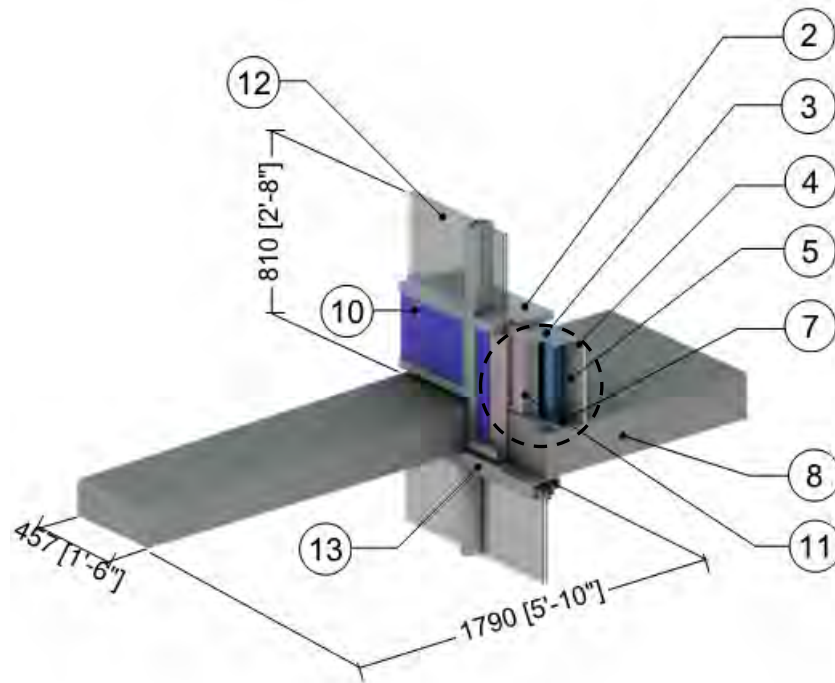

Curb Detail
(view from interior)

ID	Component	Thickness Inches (mm)	Conductivity Btu-in / ft ² ·hr·°F (W/m K)	Nominal Resistance hr·ft ² ·°F/Btu (m ² K/W)	Density lb/ft ³ (kg/m ³)	Specific Heat Btu/lb·°F (J/kg K)
1	Interior Film ¹	-	-	R-0.6 to R-1.1 (0.12 RSI to 0.20 RSI)	-	-
2	Wood Sill	2" (50)	0.69 (0.10)	-	31 (500)	0.45 (1880)
3	Steel Sheet Connected to Studs	18 Gauge	430 (62)	-	489 (7830)	0.12 (500)
4	Gypsum Board	1/2" (13)	1.1 (0.16)	R-0.5 (0.08 RSI)	50 (800)	0.26 (1090)
5	Air in Stud Cavity	Varies	-	R-0.9 (0.16 RSI)	0.075 (1.2)	0.24 (1000)
6	1 5/8" x 1 5/8" Steel Studs (16" o.c.) with Top and Bottom Tracks	18 Gauge	430 (62)	-	489 (7830)	0.12 (500)
7	3 5/8" x 1 5/8" Steel Studs (16" o.c.) with Top and Bottom Tracks	18 Gauge	430 (62)	-	489 (7830)	0.12 (500)
8	Concrete Slab	8" (203)	12.5 (1.8)	-	140 (2250)	0.20 (850)
9	Concrete Curb	6" (152)	12.5 (1.8)	-	140 (2250)	0.20 (850)
10	Thermally Broken Aluminum Sliding Door ² , double glazed IGU U _{IGU} = 0.32 BTU/hr·ft ² ·°F (1.82 W/m ² K)					
11	Back Pan Insulation	Varies	0.24 (0.034)	R-6.4 to R-12.8 (1.13 RSI to 2.25 RSI)	4 (64)	0.20 (850)
12	Aluminum Window Wall Vision System ² : thermally broken frame, double glazed IGU U _{IGU} = 0.32 BTU/hr·ft ² ·°F (1.82 W/m ² K)					
13	Aluminum Flashing	14 Gauge	1109 (160)	-	171 (2739)	0.21 (900)
14	Exterior Film ¹	-	-	R-0.2 (0.03 RSI)	-	-

¹ Value selected from table 1, p. 26.1 of 2009 ASHRAE Handbook – Fundamentals depending on surface orientation

² The thermal conductivity of air spaces within framing was found using ISO 100077-2

Detail 9.1.10

Interior Insulated 3 5/8" x 1 5/8" Steel Stud (16" o.c.) Wall Assembly - Door Sill with Exterior Slab Insulation

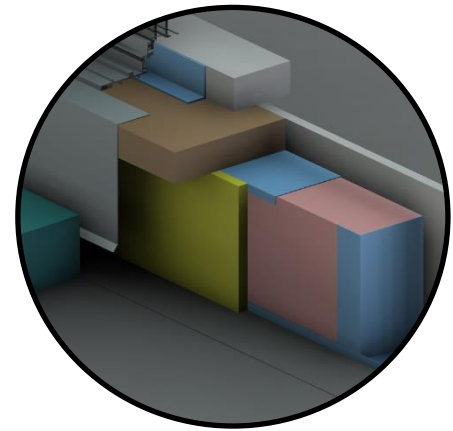
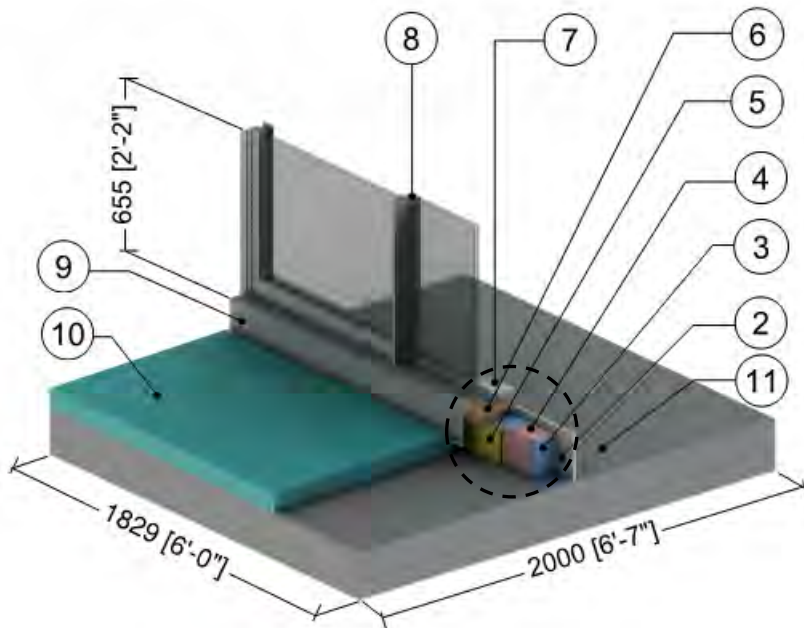

Curb Detail

ID	Component	Thickness Inches (mm)	Conductivity Btu-in / ft ² ·hr·°F (W/m K)	Nominal Resistance hr·ft ² ·°F/Btu (m ² K/W)	Density lb/ft ³ (kg/m ³)	Specific Heat Btu/lb·°F (J/kg K)
1	Interior Films ¹	-	-	R-0.6 to R-0.7 (0.11 RSI to 0.12 RSI)	-	-
2	Gypsum Board	1/2" (13)	1.1 (0.16)	R-0.5 (0.08 RSI)	50 (800)	0.26 (1090)
3	3 5/8" x 1 5/8" Steel Studs (16" o.c.) with Top Tracks	18 Gauge	430 (62)	-	489 (7830)	0.12 (500)
4	Fiberglass Batt Insulation	3 5/8" (92)	0.29 (0.042)	R-12 (2.1 RSI)	0.9 (14)	0.17 (710)
5	Exterior Sheathing	1/2" (13)	1.1 (0.16)	R-0.5 (0.09 RSI)	50 (800)	0.26 (1090)
6	Wood Blocking	1 5/8" (161)	0.69 (0.1)	-	31 (500)	0.45 (1880)
7	Wood Sill	3 1/4" (82)	0.69 (0.1)	-	31 (500)	0.45 (1880)
8	Thermally Broken Aluminum Sliding Door ² , double glazed IGU U _{IGU} = 0.32 BTU/hr·ft ² ·°F (1.82 W/m ² K)					
9	Aluminum Flashing	18 Gauge	430 (62)	-	489 (7830)	0.12 (500)
10	Deck Insulation	3" (75)	0.20 (0.029)	R-15 (2.6 RSI)	1.8 (28)	0.29 (1220)
11	Concrete Slab	8" (203)	12.5 (1.8)	-	140 (2250)	0.20 (850)
12	Exterior Film ¹	-	-	R-0.2 to R-0.7 (0.03 RSI to 0.12 RSI)	-	-

¹ Value selected from table 1, p. 26.1 of 2009 ASHRAE Handbook – Fundamentals depending on surface orientation

² The thermal conductivity of air spaces within sliding door framing was found using ISO 10077-2

Detail 9.1.11

Exterior and Interior Insulated 3 5/8" x 1 5/8" Steel Stud (16" o.c.) Wall Assembly - Door Sill with Exterior Slab Insulation

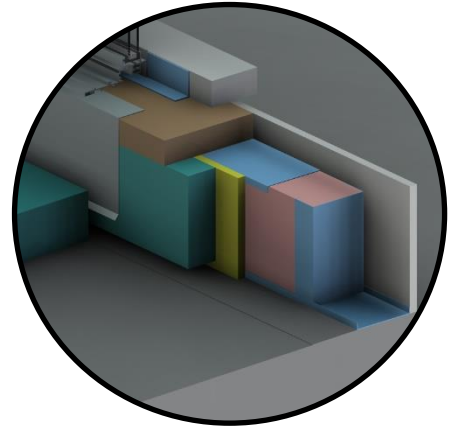
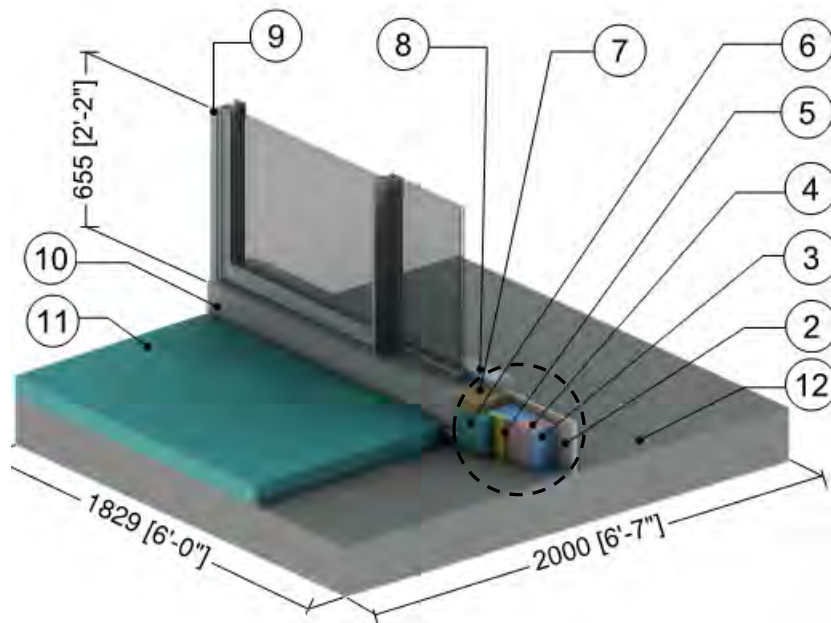

Curb Detail

ID	Component	Thickness Inches (mm)	Conductivity Btu-in / ft ² ·hr·°F (W/m K)	Nominal Resistance hr·ft ² ·°F/Btu (m ² K/W)	Density lb/ft ³ (kg/m ³)	Specific Heat Btu/lb·°F (J/kg K)
1	Interior Film ¹	-	-	R-0.6 to R-0.7 (0.11 RSI to 0.12 RSI)	-	-
2	Gypsum Board	1/2" (13)	1.1 (0.16)	R-0.5 (0.08 RSI)	50 (800)	0.26 (1090)
3	3 5/8" x 1 5/8" Steel Studs (16" o.c.) with Top Track	18 Gauge	430 (62)	-	489 (7830)	0.12 (500)
4	Fiberglass Batt Insulation	3 5/8" (92)	0.29 (0.042)	R-12 (2.1 RSI)	0.9 (14)	0.17 (710)
5	Exterior Sheathing	1/2" (13)	1.1 (0.16)	R-0.5 (0.09 RSI)	50 (800)	0.26 (1090)
6	Exterior Insulation	Varies	-	R-10 to R-15 (1.76 RSI to 2.64 RSI)	1.8 (28)	0.29 (1220)
7	Wood Blocking	1 5/8" (161)	0.69 (0.1)	-	27.8 (445)	0.45 (1880)
8	Wood Sill	3 1/4" (82)	0.69 (0.1)	-	27.8 (445)	0.45 (1880)
9	Thermally Broken Aluminum Sliding Door ² , double glazed IGU U _{IGU} = 0.32 BTU/hr·ft ² ·°F (1.82 W/m ² K)					
10	Steel Flashing	18 Gauge	430 (62)	-	489 (7830)	0.12 (500)
11	Deck Insulation	3" (75)	0.20 (0.029)	R-15 (2.6 RSI)	1.8 (28)	0.29 (1220)
12	Concrete Slab	8" (203)	12.5 (1.8)	-	140 (2250)	0.20 (850)
13	Exterior Film ¹	-	-	R-0.2 to R-0.7 (0.03 RSI to 0.12 RSI)	-	-

¹ Value selected from table 1, p. 26.1 of 2009 ASHRAE Handbook – Fundamentals depending on surface orientation

² The thermal conductivity of air spaces within sliding door framing was found using ISO 10077-2

Detail 9.1.12

Window Wall System with Spandrel Panels and Sliding Door - Schöck Isokorb K65-V8 Thermal Break at Concrete Balcony and Curb Intersection

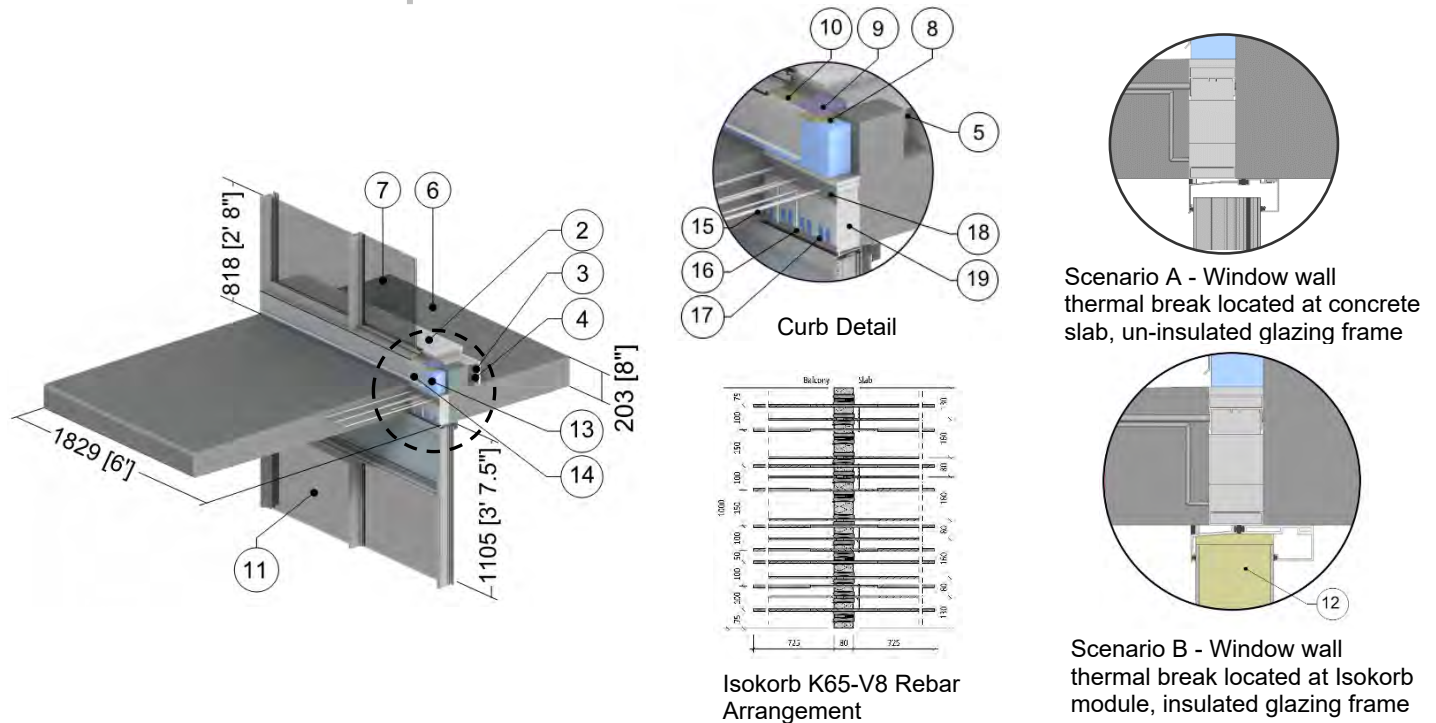

ID	Component	Thickness Inches (mm)	Conductivity Btu-in / ft ² ·hr·°F (W/m K)	Nominal Resistance hr·ft ² ·°F/Btu (m ² K/W)	Density lb/ft ³ (kg/m ³)	Specific Heat Btu/lb·°F (J/kg K)
1	Interior Film ¹	-	-	R-0.6 to R-1.1 (0.12 RSI to 0.20 RSI)	-	-
2	Wood Sill	1.4" (36)	0.69 (0.10)	-	31 (500)	0.45 (1880)
3	Gypsum Board	1/2" (13)	1.1 (0.16)	R-0.5 (0.08 RSI)	50 (800)	0.26 (1090)
4	Air in Stud Cavity	Varies	-	R-0.9 (0.16 RSI)	0.075 (1.2)	0.24 (1000)
5	1 5/8" x 1 5/8" Steel Studs (16" o.c.) with Top and Bottom Tracks	18 Gauge	430 (62)	-	489 (7830)	0.12 (500)
6	Concrete Curb and Slab	-	12.5 (1.8)	-	140 (2250)	0.20 (850)
7	Thermally Broken Aluminum Sliding Door ² , double glazed IGU U _{IGU} = 0.32 BTU/hr·ft ² ·°F (1.82 W/m ² K)					
8	Support Angle	1/2" (13)	347 (50)	-	489 (7830)	0.12 (500)
9	Support Shims	3/8" (10)	1.7 (0.25)	-	72 (1150)	0.20 (850)
10	Wood Liner	5/8" (16)	0.69 (0.10)	-	31 (500)	0.45 (1880)
11	Aluminum Window Wall Vision System ² : thermally broken frame, double glazed IGU U _{IGU} = 0.32 BTU/hr·ft ² ·°F (1.82 W/m ² K)					
12	Deflection Header Frame Insulation	Varies	0.24 (0.034)	-	4 (64)	0.20 (850)
13	Exterior Insulation	3" (76)	-	R-15 (2.64 RSI)	1.8 (28)	0.29 (1220)
14	Flashing	18 Gauge	430 (62)	-	489 (7830)	0.12 (500)
15	Steel Rebar	-	347 (50)	-	489 (7830)	0.12 (500)
16	Stainless Steel Rebar	-	118 (17)	-	500 (8000)	0.12 (500)
17	Plastic Sleeve	-	1.7 (0.25)	-	72 (1150)	0.20 (850)
18	Isokorb Frame	-	1.7 (0.25)	-	72 (1150)	0.20 (850)
19	Polystyrene Insulation	3.2" (80)	0.22 (0.031)	R-15 (2.58 RSI)	1.3 (20)	0.35 (1500)
20	Exterior Film ¹	-	-	R-0.2 (0.03 RSI)	-	-

¹ Value selected from table 1, p. 26.1 of 2009 ASHRAE Handbook – Fundamentals depending on surface orientation

² The thermal conductivity of air spaces within framing was found using ISO 100077-2

Detail 9.1.13

Window Wall System with Spandrel Panels and Sliding Door - Schöck Isokorb K10-V6 Thermal Break at Concrete Balcony and Curb Intersection

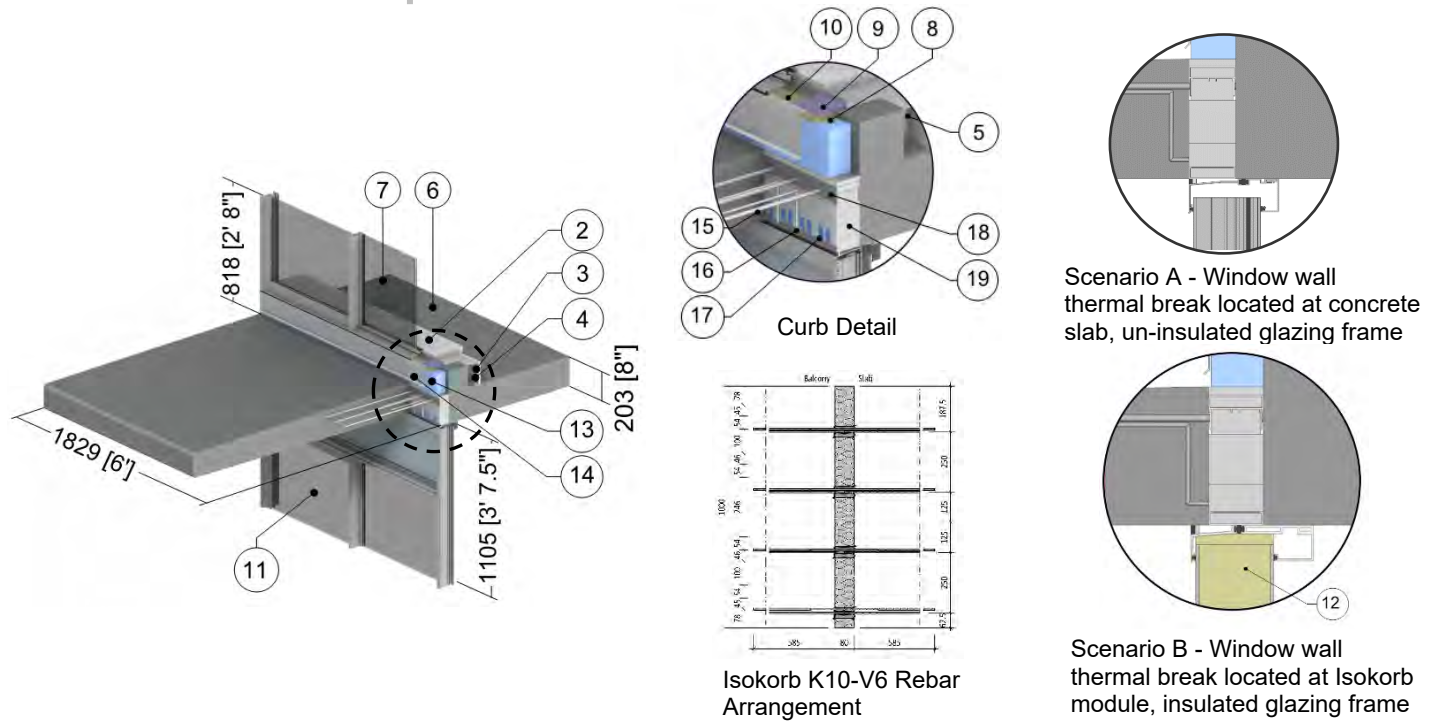

ID	Component	Thickness Inches (mm)	Conductivity Btu-in / ft ² ·hr·°F (W/m K)	Nominal Resistance hr·ft ² ·°F/Btu (m ² K/W)	Density lb/ft ³ (kg/m ³)	Specific Heat Btu/lb·°F (J/kg K)
1	Interior Film ¹	-	-	R-0.6 to R-1.1 (0.12 RSI to 0.20 RSI)	-	-
2	Wood Sill	1.4" (36)	0.69 (0.10)	-	31 (500)	0.45 (1880)
3	Gypsum Board	1/2" (13)	1.1 (0.16)	R-0.5 (0.08 RSI)	50 (800)	0.26 (1090)
4	Air in Stud Cavity	Varies	-	R-0.9 (0.16 RSI)	0.075 (1.2)	0.24 (1000)
5	1 5/8" x 1 5/8" Steel Studs (16" o.c.) with Top and Bottom Tracks	18 Gauge	430 (62)	-	489 (7830)	0.12 (500)
6	Concrete Curb and Slab	-	12.5 (1.8)	-	140 (2250)	0.20 (850)
7	Thermally Broken Aluminum Sliding Door ² , double glazed IGU U _{IGU} = 0.32 BTU/hr·ft ² ·°F (1.82 W/m ² K)					
8	Support Angle	1/2" (13)	347 (50)	-	489 (7830)	0.12 (500)
9	Support Shims	3/8" (10)	1.7 (0.25)	-	72 (1150)	0.20 (850)
10	Wood Liner	5/8" (16)	0.69 (0.10)	-	31 (500)	0.45 (1880)
11	Aluminum Window Wall Vision System ² : thermally broken frame, double glazed IGU U _{IGU} = 0.32 BTU/hr·ft ² ·°F (1.82 W/m ² K)					
12	Deflection Header Frame Insulation	Varies	0.24 (0.034)	-	4 (64)	0.20 (850)
13	Exterior Insulation	3" (76)	-	R-15 (2.64 RSI)	1.8 (28)	0.29 (1220)
14	Flashing	18 Gauge	430 (62)	-	489 (7830)	0.12 (500)
15	Steel Rebar	-	347 (50)	-	489 (7830)	0.12 (500)
16	Stainless Steel Rebar	-	118 (17)	-	500 (8000)	0.12 (500)
17	Plastic Sleeve	-	1.7 (0.25)	-	72 (1150)	0.20 (850)
18	Isokorb Frame	-	1.7 (0.25)	-	72 (1150)	0.20 (850)
19	Polystyrene Insulation	3.2" (80)	0.22 (0.031)	R-15 (2.58 RSI)	1.3 (20)	0.35 (1500)
20	Exterior Film ¹	-	-	R-0.2 (0.03 RSI)	-	-

¹ Value selected from table 1, p. 26.1 of 2009 ASHRAE Handbook – Fundamentals depending on surface orientation

² The thermal conductivity of air spaces within framing was found using ISO 100077-2

Detail 9.1.14

Window Wall System with Spandrel Panels and Sliding Door - Schöck Isokorb KXT65-V8 Thermal Break at Concrete Balcony and Curb Intersection

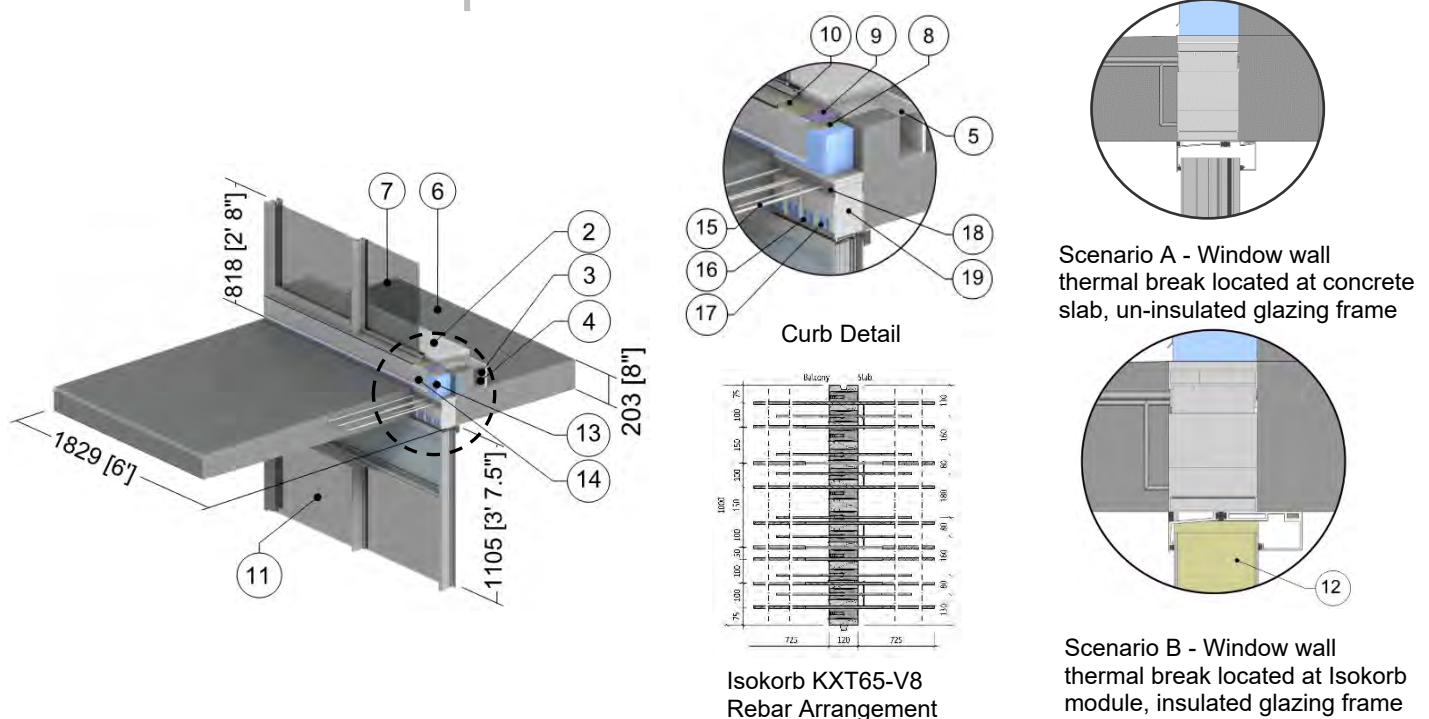

ID	Component	Thickness Inches (mm)	Conductivity Btu-in / ft ² ·hr·°F (W/m K)	Nominal Resistance hr·ft ² ·°F/Btu (m ² K/W)	Density lb/ft ³ (kg/m ³)	Specific Heat Btu/lb·°F (J/kg K)
1	Interior Film ¹	-	-	R-0.6 to R-1.1 (0.12 RSI to 0.20 RSI)	-	-
2	Wood Sill	1.4" (36)	0.69 (0.10)	-	31 (500)	0.45 (1880)
3	Gypsum Board	1/2" (13)	1.1 (0.16)	R-0.5 (0.08 RSI)	50 (800)	0.26 (1090)
4	Air in Stud Cavity	Varies	-	R-0.9 (0.16 RSI)	0.075 (1.2)	0.24 (1000)
5	1 5/8" x 1 5/8" Steel Studs (16" o.c.) with Top and Bottom Tracks	18 Gauge	430 (62)	-	489 (7830)	0.12 (500)
6	Concrete Curb and Slab	-	12.5 (1.8)	-	140 (2250)	0.20 (850)
7	Thermally Broken Aluminum Sliding Door ² , double glazed IGU U _{IGU} = 0.32 BTU/hr·ft ² ·°F (1.82 W/m ² K)					
8	Support Angle	1/2" (13)	347 (50)	-	489 (7830)	0.12 (500)
9	Support Shims	3/8" (10)	1.7 (0.25)	-	72 (1150)	0.20 (850)
10	Wood Liner	5/8" (16)	0.69 (0.10)	-	31 (500)	0.45 (1880)
11	Aluminum Window Wall Vision System ² : thermally broken frame, double glazed IGU U _{IGU} = 0.32 BTU/hr·ft ² ·°F (1.82 W/m ² K)					
12	Deflection Header Frame Insulation	Varies	0.24 (0.034)	-	4 (64)	0.20 (850)
13	Exterior Insulation	4.5" (114)	-	R-22.5 (3.96 RSI)	1.8 (28)	0.29 (1220)
14	Flashing	18 Gauge	430 (62)	-	489 (7830)	0.12 (500)
15	Steel Rebar	-	347 (50)	-	489 (7830)	0.12 (500)
16	Stainless Steel Rebar	-	118 (17)	-	500 (8000)	0.12 (500)
17	Plastic Sleeve	-	1.7 (0.25)	-	72 (1150)	0.20 (850)
18	Isokorb Frame	-	1.7 (0.25)	-	72 (1150)	0.20 (850)
19	Polystyrene Insulation	4.7" (120)	0.22 (0.031)	R-21.7 (3.83 RSI)	1.3 (20)	0.35 (1500)
20	Exterior Film ¹	-	-	R-0.2 (0.03 RSI)	-	-

¹ Value selected from table 1, p. 26.1 of 2009 ASHRAE Handbook – Fundamentals depending on surface orientation

² The thermal conductivity of air spaces within framing was found using ISO 100077-2

Detail 9.1.15

Window Wall System with Spandrel Panels and Sliding Door - Schöck Isokorb KXT15-V6 Thermal Break at Concrete Balcony and Curb Intersection

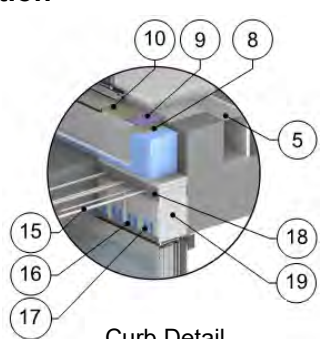
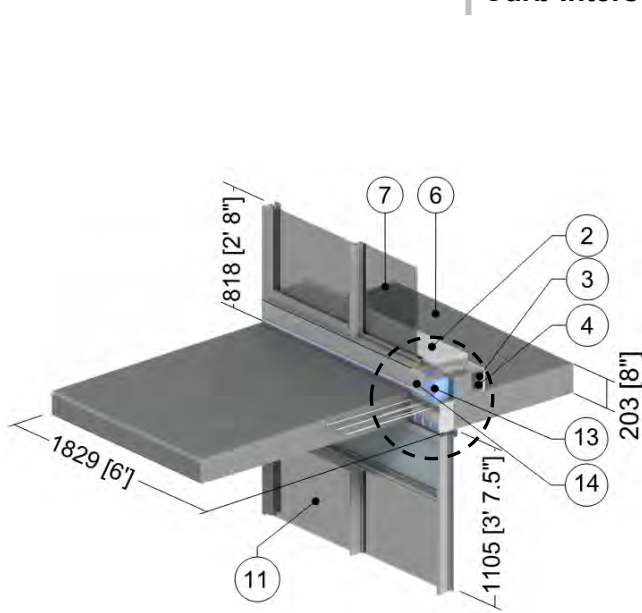

Curb Detail

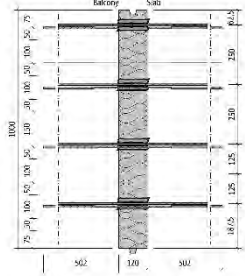

Isokorb KXT15-V6 Rebar Arrangement

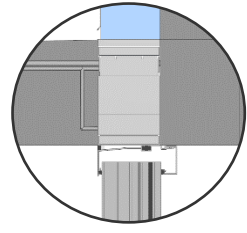

Scenario A - Window wall thermal break located at concrete slab, un-insulated glazing frame

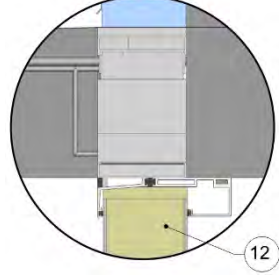

Scenario B - Window wall thermal break located at Isokorb module, insulated glazing frame

ID	Component	Thickness Inches (mm)	Conductivity Btu-in / ft ² ·hr·°F (W/m K)	Nominal Resistance hr·ft ² ·°F/Btu (m ² K/W)	Density lb/ft ³ (kg/m ³)	Specific Heat Btu/lb·°F (J/kg K)
1	Interior Film ¹	-	-	R-0.6 to R-1.1 (0.12 RSI to 0.20 RSI)	-	-
2	Wood Sill	1.4" (36)	0.69 (0.10)	-	31 (500)	0.45 (1880)
3	Gypsum Board	1/2" (13)	1.1 (0.16)	R-0.5 (0.08 RSI)	50 (800)	0.26 (1090)
4	Air in Stud Cavity	Varies	-	R-0.9 (0.16 RSI)	0.075 (1.2)	0.24 (1000)
5	1 5/8" x 1 5/8" Steel Studs (16" o.c.) with Top and Bottom Tracks	18 Gauge	430 (62)	-	489 (7830)	0.12 (500)
6	Concrete Curb and Slab	-	12.5 (1.8)	-	140 (2250)	0.20 (850)
7	Thermally Broken Aluminum Sliding Door ² , double glazed IGU U _{IGU} = 0.32 BTU/hr·ft ² ·°F (1.82 W/m ² K)					
8	Support Angle	1/2" (13)	347 (50)	-	489 (7830)	0.12 (500)
9	Support Shims	3/8" (10)	1.7 (0.25)	-	72 (1150)	0.20 (850)
10	Wood Liner	5/8" (16)	0.69 (0.10)	-	31 (500)	0.45 (1880)
11	Aluminum Window Wall Vision System ² : thermally broken frame, double glazed IGU U _{IGU} = 0.32 BTU/hr·ft ² ·°F (1.82 W/m ² K)					
12	Deflection Header Frame Insulation	Varies	0.24 (0.034)	-	4 (64)	0.20 (850)
13	Exterior Insulation	4.5" (114)	-	R-22.5 (3.96 RSI)	1.8 (28)	0.29 (1220)
14	Flashing	18 Gauge	430 (62)	-	489 (7830)	0.12 (500)
15	Steel Rebar	-	347 (50)	-	489 (7830)	0.12 (500)
16	Stainless Steel Rebar	-	118 (17)	-	500 (8000)	0.12 (500)
17	Plastic Sleeve	-	1.7 (0.25)	-	72 (1150)	0.20 (850)
18	Isokorb Frame	-	1.7 (0.25)	-	72 (1150)	0.20 (850)
19	Polystyrene Insulation	4.7" (120)	0.22 (0.031)	R-21.7 (3.83 RSI)	1.3 (20)	0.35 (1500)
20	Exterior Film ¹	-	-	R-0.2 (0.03 RSI)	-	-

¹ Value selected from table 1, p. 26.1 of 2009 ASHRAE Handbook – Fundamentals depending on surface orientation

² The thermal conductivity of air spaces within framing was found using ISO 100077-2

Detail 9.1.16

Exterior Insulated 2"x6" Steel Stud (16" o.c.) Wall Assembly with FRP Vertical Brackets and Rail System Supporting Metal Cladding and Sliding Door – Intermittently Attached Balcony and Sliding Door Intersection

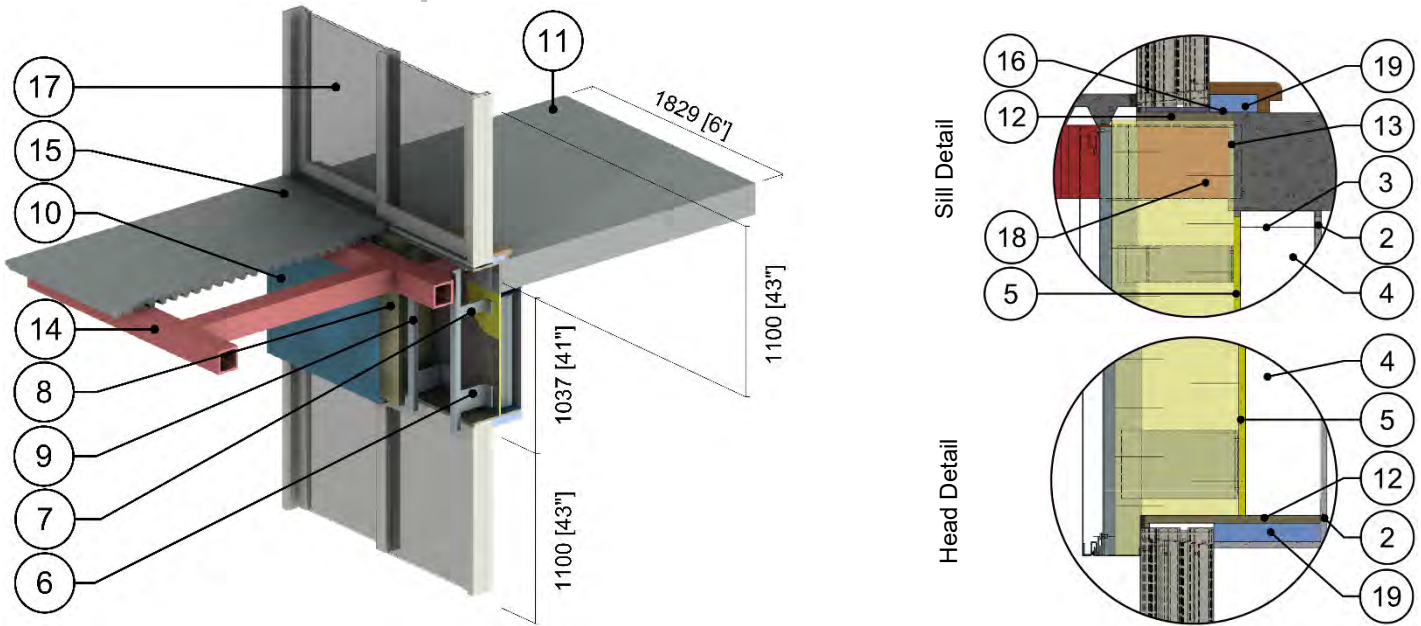

ID	Component	Thickness Inches (mm)	Conductivity Btu-in / ft ² ·hr·°F (W/m K)	Nominal Resistance hr·ft ² ·°F/Btu (m ² K/W)	Density lb/ft ³ (kg/m ³)	Specific Heat Btu/lb·°F (J/kg K)
1	Interior Film ¹	-	-	R-0.6 to R-1.1 (0.11 to 0.20 RSI)	-	-
2	Gypsum Board	1/2" (13)	1.1 (0.16)	R-0.5 (0.08 RSI)	50 (800)	0.26 (1090)
3	2" x 6" Steel Studs with Tracks	18 Gauge	430 (62)	-	489 (7830)	0.12 (500)
4	Air in Stud Cavity	6" (152)	-	R-0.9 (0.16 RSI)	-	0.24 (1000)
5	Exterior Sheathing	1/2" (13)	1.1 (0.16)	R-0.5 (0.08 RSI)	50 (800)	0.26 (1090)
6	FRP Bracket	-	4.85 (0.7)	-	110 (1760)	-
7	Aluminum Bracket	-	1110 (160)	-	171 (2739)	0.22 (900)
8	Exterior Mineral Wool Insulation	10" (254)	0.24 (0.034)	R-42 (7.40 RSI)	4.5 (72)	0.20 (850)
9	Vertical Aluminum L-Rail	0.09" (2.2)	1110 (160)	-	171 (2739)	0.22 (900)
10	Metal Cladding with 1/2" vented airspace incorporated into exterior heat transfer coefficient					
11	Concrete Slab	8" (203)	12.5 (1.8)	-	140 (2250)	0.20 (850)
12	Wood Liner	1/2" (13)	0.69 (0.10)	-	31 (500)	0.45 (1880)
13	Steel Support Angle	1/2" (13)	430 (62)	-	489 (7830)	0.12 (500)
14	Steel Balcony Framing	5/8" (16)	430 (62)	-	489 (7830)	0.12 (500)
15	Concrete Balcony Topping	2.5" (64)	12.5 (1.8)	-	140 (2250)	0.20 (850)
16	Aluminum Back Angle	0.09" (2.2)	1110 (160)	-	171 (2739)	0.22 (900)
17	Thermally broken vinyl sliding door ² , triple glazed IGU U _{IGU} = 0.13 BTU/hr·ft ² ·°F (0.72 W/m ² K)					
18	Steel Column and Knife Edge	5/8" (16)	430 (62)	-	489 (7830)	0.12 (500)
19	Rigid Insulation	-	0.20 (0.029)	-	1.8 (28)	0.29 (1220)
20	Exterior Film ¹	-	-	R-0.2 to R-0.7 (0.03 to 0.12 RSI)	-	-

¹ Value selected from table 1, p. 26.1 of 2009 ASHRAE Handbook – Fundamentals depending on surface orientation

² The thermal conductivity of air spaces within framing was found using ISO 100077-2

Detail 9.1.17

Exterior and Interior Insulated 2"x6" Steel Stud (16" o.c.) Wall Assembly with FRP Vertical Brackets and Rail System Supporting Metal Cladding with R-19 Batt in Stud Cavity and Sliding Door – Intermittently Attached Balcony and Sliding Door Intersection

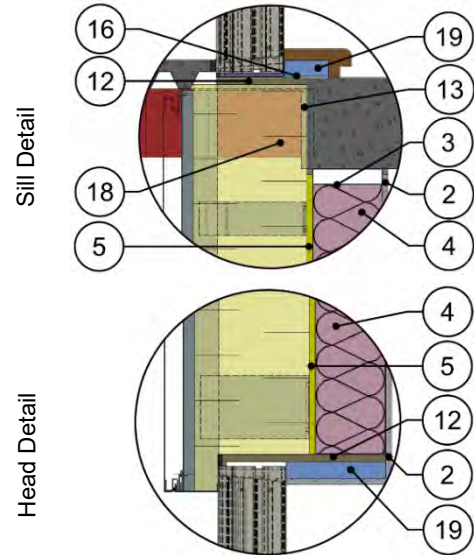
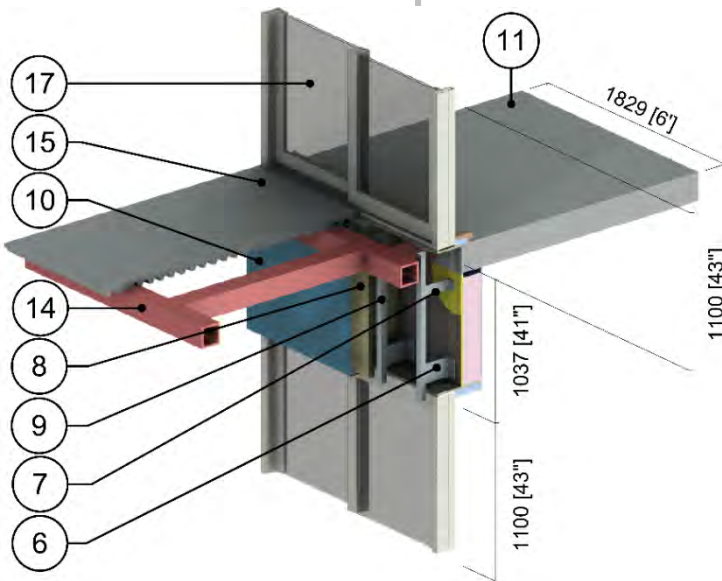

ID	Component	Thickness Inches (mm)	Conductivity Btu-in / ft ² ·hr·°F (W/m K)	Nominal Resistance hr·ft ² ·°F/Btu (m ² K/W)	Density lb/ft ³ (kg/m ³)	Specific Heat Btu/lb·°F (J/kg K)
1	Interior Film ¹	-	-	R-0.6 to R-1.1 (0.11 to 0.20 RSI)	-	-
2	Gypsum Board	1/2" (13)	1.1 (0.16)	R-0.5 (0.08 RSI)	50 (800)	0.26 (1090)
3	2" x 6" Steel Studs with Tracks	18 Gauge	430 (62)	-	489 (7830)	0.12 (500)
4	Fiberglass Batt Insulation	6" (152)	-	R-19 (3.35 RSI)	0.9 (14)	0.17 (710)
5	Exterior Sheathing	1/2" (13)	1.1 (0.16)	R-0.5 (0.08 RSI)	50 (800)	0.26 (1090)
6	FRP Bracket	-	4.85 (0.7)	-	110 (1760)	-
7	Aluminum Bracket	-	1110 (160)	-	171 (2739)	0.22 (900)
8	Exterior Mineral Wool Insulation	10" (254)	0.24 (0.034)	R-42 (7.40 RSI)	4.5 (72)	0.20 (850)
9	Vertical Aluminum L-Rail	0.09" (2.2)	1110 (160)	-	171 (2739)	0.22 (900)
10	Metal Cladding with 1/2" vented airspace incorporated into exterior heat transfer coefficient					
11	Concrete Slab	8" (203)	12.5 (1.8)	-	140 (2250)	0.20 (850)
12	Wood Liner	1/2" (13)	0.69 (0.10)	-	31 (500)	0.45 (1880)
13	Steel Support Angle	1/2" (13)	430 (62)	-	489 (7830)	0.12 (500)
14	Steel Balcony Framing	5/8" (16)	430 (62)	-	489 (7830)	0.12 (500)
15	Concrete Balcony Topping	2.5" (64)	12.5 (1.8)	-	140 (2250)	0.20 (850)
16	Aluminum Back Angle	0.09" (2.2)	1110 (160)	-	171 (2739)	0.22 (900)
17	Thermally broken vinyl sliding door ² , triple glazed IGU U _{IGU} = 0.13 BTU/hr·ft ² ·°F (0.72 W/m ² K)					
18	Steel Column and Knife Edge	5/8" (16)	430 (62)	-	489 (7830)	0.12 (500)
19	Rigid Insulation	-	0.20 (0.029)	-	1.8 (28)	0.29 (1220)
20	Exterior Film ¹	-	-	R-0.2 to R-0.7 (0.03 to 0.12 RSI)	-	-

¹ Value selected from table 1, p. 26.1 of 2009 ASHRAE Handbook – Fundamentals depending on surface orientation

² The thermal conductivity of air spaces within framing was found using ISO 100077-2

Detail 9.1.18

Exterior Insulated 2" x 6" Steel Stud (16" o.c.) Wall Assembly with Vertical Clips (24" o.c.) Supporting Cladding and Sliding Door – Concrete Balcony and Curb Intersection

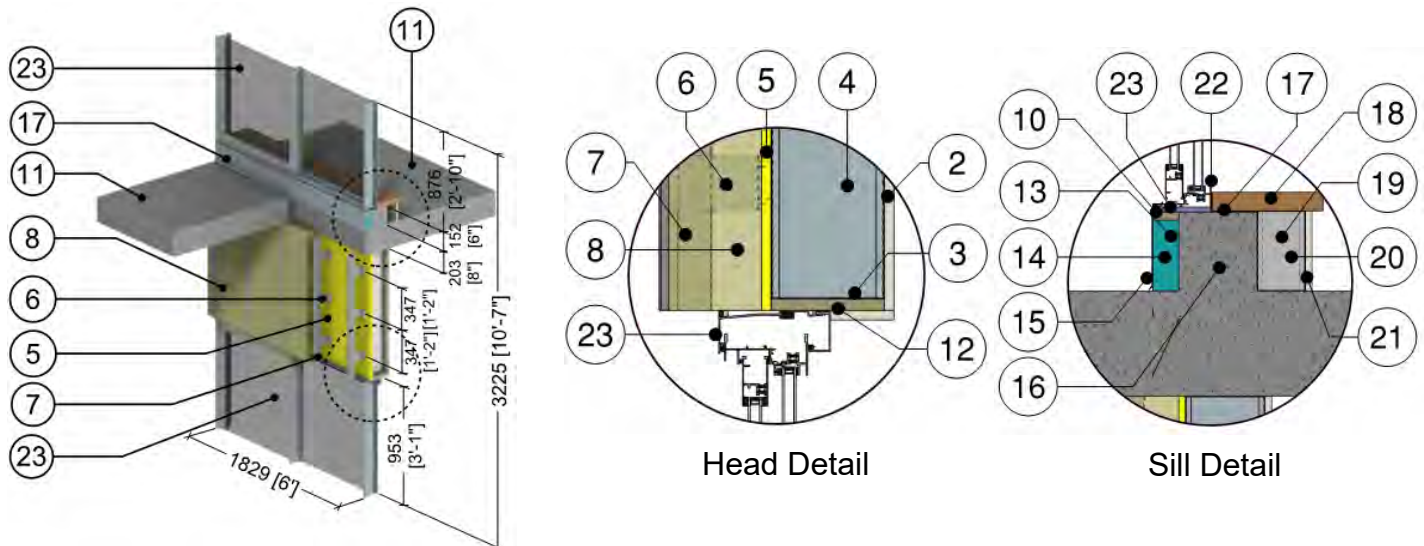

ID	Component	Thickness Inches (mm)	Conductivity Btu-in / ft ² -hr-°F (W/m K)	Nominal Resistance hr-ft ² -°F/Btu (m ² K/W)	Density lb/ft ³ (kg/m ³)	Specific Heat Btu/lb-°F (J/kg K)
1	Interior Film ¹	-	-	R-0.6 to R-1.1 (0.11 to 0.20 RSI)	-	-
2	Gypsum Board	1/2" (13)	1.1 (0.16)	R-0.5 (0.08 RSI)	50 (800)	0.26 (1090)
3	2" x 6" Steel Studs with Tracks	18 Gauge	430 (62)	-	489 (7830)	0.12 (500)
4	Air in Stud Cavity	6" (152)	-	R-0.9 (0.16 RSI)	-	0.24 (1000)
5	Exterior Sheathing	1/2" (13)	1.1 (0.16)	R-0.5 (0.08 RSI)	50 (800)	0.26 (1090)
6	Thermally Isolated Aluminum Bracket	0.09" (2.2)	-	-	-	-
7	Vertical Aluminum L-girt	0.09" (2.2)	1340 (193)	-	169 (2700)	0.22 (900)
8	Exterior Mineral Wool Insulation	Varies	0.24 (0.034)	R-4.2 to R-21 (0.74 to 3.70 RSI)	-	-
9	Generic Cladding with 1/2" (13 mm) vented air space incorporated into exterior heat transfer coefficient					
10	Wood Buck	5/8" (16)	0.69 (0.10)	-	31 (500)	0.45 (1880)
11	Concrete Slab	8" (203)	12.5 (1.8)	-	140 (2250)	0.20 (850)
12	Wood Liner	1/2" (16)	0.69 (0.10)	-	31 (500)	0.45 (1880)
13	Steel Support Angle	1/4" (6)	430 (62)	-	489 (7830)	0.12 (500)
14	XPS Curb Insulation	2" (51)	0.02 (0.029)	R-10 (1.76 RSI)	1.8 (28)	0.29 (1220)
15	Aluminum Flashing	18 Gauge	1110 (160)	-	171 (2739)	0.22 (900)
16	Concrete Curb	8" (203)	12.5 (1.8)	-	140 (2250)	0.20 (850)
17	Steel Back Angle	18 Gauge	430 (62)	-	489 (7830)	0.12 (500)
18	Wood Sill	1 1/2" (38)	0.69 (0.10)	-	31 (500)	0.45 (1880)
19	3 5/8" x 1 5/8" Steel Studs with Tracks	18 Gauge	430 (62)	-	489 (7830)	0.12 (500)
20	Air in Stud Cavity	3 5/8" (92)	-	R-0.9 (0.16 RSI)	-	0.24 (1000)
21	Gypsum Board	1/2" (13)	1.1 (0.16)	R-0.5 (0.08 RSI)	50 (800)	0.26 (1090)
22	Thermally broken aluminum sliding door ² , double glazed IGU U _{IGU} = 0.32 BTU/hr-ft ² -°F (1.82 W/m ² K)					
23	Polyamide Shim	1/2" (10)	1.73 (0.25)	-	-	-
24	Exterior Film ¹	-	-	R-0.2 to R-0.7 (0.03 to 0.12 RSI)	-	-

¹ Value selected from table 1, p. 26.1 of 2009 ASHRAE Handbook – Fundamentals depending on surface orientation

²The thermal conductivity of air spaces within framing was found using ISO 100077-2

Detail 9.1.19

Exterior and Interior Insulated 2" x 6" Steel Stud (16" o.c.) Wall Assembly with Vertical Clips (24" o.c.) Supporting Cladding with R-19 Batt in Stud Cavity and Sliding Door – Concrete Balcony and Curb Intersection

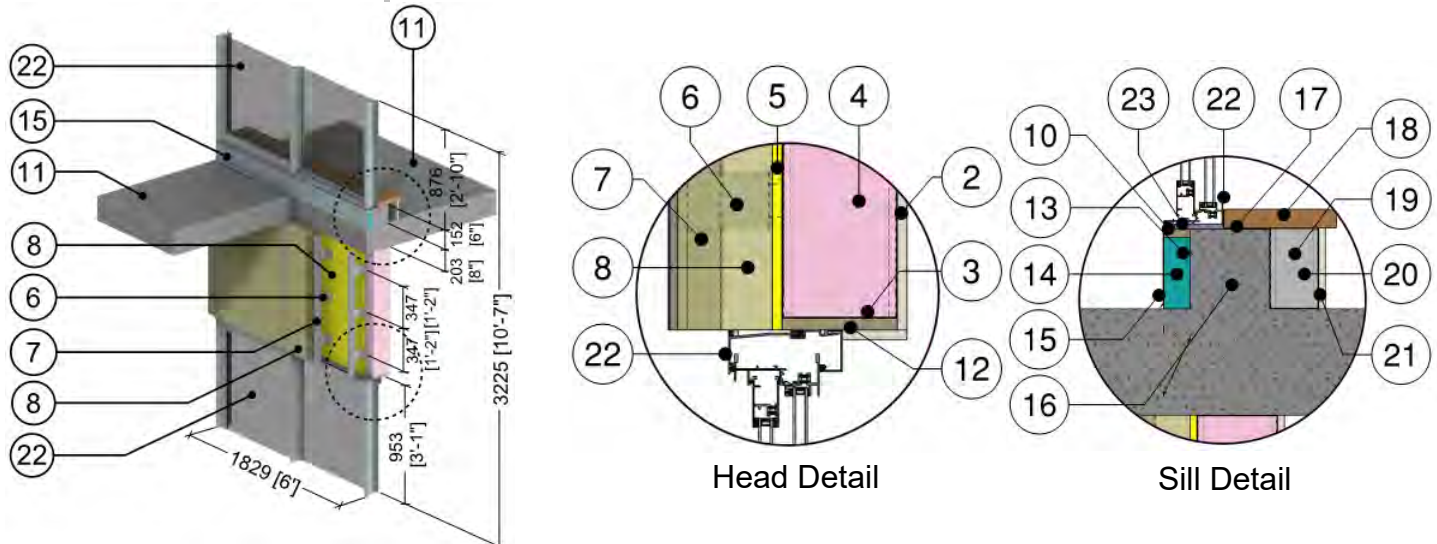

ID	Component	Thickness Inches (mm)	Conductivity Btu-in / ft ² -hr-°F (W/m K)	Nominal Resistance hr-ft ² -°F/Btu (m ² K/W)	Density lb/ft ³ (kg/m ³)	Specific Heat Btu/lb-°F (J/kg K)
1	Interior Film ¹	-	-	R-0.6 to R-1.1 (0.11 to 0.20 RSI)	-	-
2	Gypsum Board	1/2" (13)	1.1 (0.16)	R-0.5 (0.08 RSI)	50 (800)	0.26 (1090)
3	2" x 6" Steel Studs with Tracks	18 Gauge	430 (62)	-	489 (7830)	0.12 (500)
4	Fiberglass Batt Insulation	6" (152)	0.32 (0.046)	R-19 (0.16 RSI)	0.9 (1.4)	0.17 (710)
5	Exterior Sheathing	1/2" (13)	1.1 (0.16)	R-0.5 (0.08 RSI)	50 (800)	0.26 (1090)
6	Thermally Isolated Aluminum Bracket	0.09" (2.2)	-	-	-	-
7	Vertical Aluminum L-girt	0.09" (2.2)	1340 (193)	-	169 (2700)	0.22 (900)
8	Exterior Mineral Wool Insulation	Varies	0.24 (0.034)	R-4.2 to R-21 (0.74 to 3.70 RSI)	-	-
9	Generic Cladding with 1/2" (13 mm) vented air space incorporated into exterior heat transfer coefficient					
10	Wood Buck	5/8" (16)	0.69 (0.10)	-	31 (500)	0.45 (1880)
11	Concrete Slab	8" (203)	12.5 (1.8)	-	140 (2250)	0.20 (850)
12	Wood Liner	1/2" (16)	0.69 (0.10)	-	31 (500)	0.45 (1880)
13	Steel Support Angle	1/4" (6)	430 (62)	-	489 (7830)	0.12 (500)
14	XPS Curb Insulation	2" (51)	0.02 (0.029)	R-10 (1.76 RSI)	1.8 (28)	0.29 (1220)
15	Aluminum Flashing	18 Gauge	1110 (160)	-	171 (2739)	0.22 (900)
16	Concrete Curb	8" (203)	12.5 (1.8)	-	140 (2250)	0.20 (850)
17	Steel Back Angle	18 Gauge	430 (62)	-	489 (7830)	0.12 (500)
18	Wood Sill	1 1/2" (38)	0.69 (0.10)	-	31 (500)	0.45 (1880)
19	3 5/8" x 1 5/8" Steel Studs with Tracks	18 Gauge	430 (62)	-	489 (7830)	0.12 (500)
20	Air in Stud Cavity	3 5/8" (92)	-	R-0.9 (0.16 RSI)	-	0.24 (1000)
21	Gypsum Board	1/2" (13)	1.1 (0.16)	R-0.5 (0.08 RSI)	50 (800)	0.26 (1090)
22	Thermally broken aluminum sliding door ² , double glazed IGU U _{IGU} = 0.32 BTU/hr-ft ² -°F (1.82 W/m ² K)					
23	Polyamide Shim	1/2" (10)	1.73 (0.25)	-	-	-
24	Exterior Film ¹	-	-	R-0.2 to R-0.7 (0.03 to 0.12 RSI)	-	-

¹ Value selected from table 1, p. 26.1 of 2009 ASHRAE Handbook – Fundamentals depending on surface orientation

²The thermal conductivity of air spaces within framing was found using ISO 100077-2

Detail 9.1.20

Exterior Insulated 2" x 6" Steel Stud (16" o.c.) Wall Assembly with Vertical Clips (24" o.c.) Supporting Cladding and Sliding Door – Structural Thermal Break at Concrete Balcony and Curb Intersection

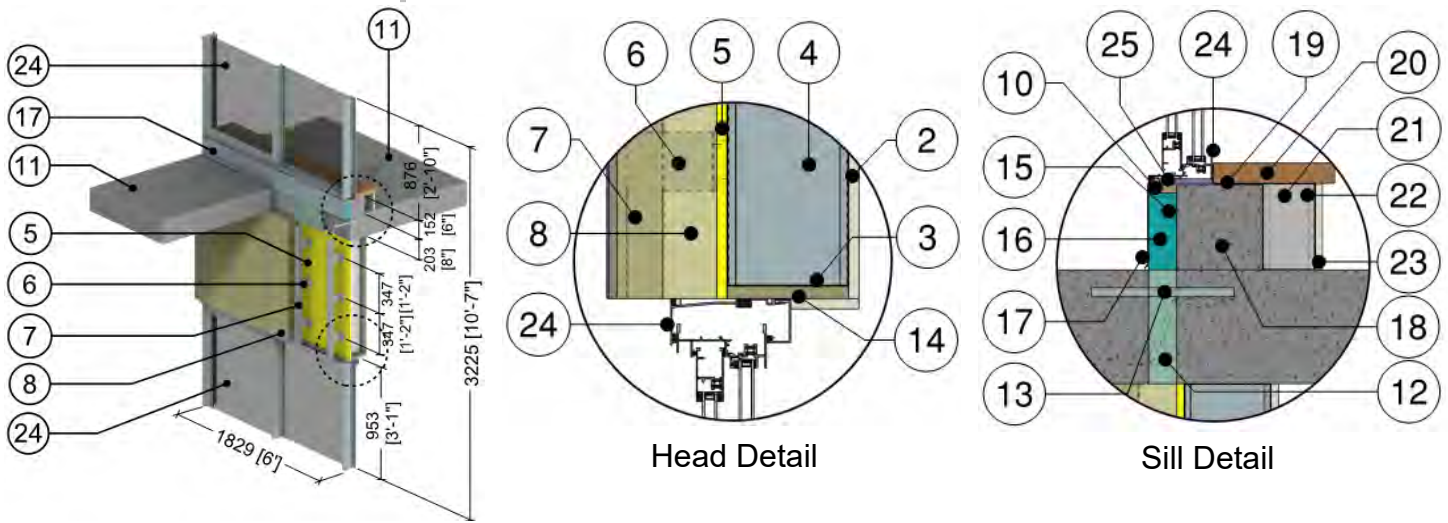

ID	Component	Thickness Inches (mm)	Conductivity Btu-in / ft ² ·hr·°F (W/m K)	Nominal Resistance hr·ft ² ·°F/Btu (m ² K/W)	Density lb/ft ³ (kg/m ³)	Specific Heat Btu/lb·°F (J/kg K)
1	Interior Film ¹	-	-	R-0.6 to R-1.1 (0.11 to 0.20 RSI)	-	-
2	Gypsum Board	1/2" (13)	1.1 (0.16)	R-0.5 (0.08 RSI)	50 (800)	0.26 (1090)
3	2" x 6" Steel Studs with Tracks	18 Gauge	430 (62)	-	489 (7830)	0.12 (500)
4	Air in Stud Cavity	6" (152)	-	R-0.9 (0.16 RSI)	-	0.24 (1000)
5	Exterior Sheathing	1/2" (13)	1.1 (0.16)	R-0.5 (0.08 RSI)	50 (800)	0.26 (1090)
6	Thermally Isolated Aluminum Bracket	0.09" (2.2)	-	-	-	-
7	Vertical Aluminum L-girt	0.09" (2.2)	1340 (193)	-	169 (2700)	0.22 (900)
8	Exterior Mineral Wool Insulation	Varies	0.24 (0.034)	R-4.2 to R-21 (0.74 to 3.70 RSI)	-	-
9	Generic Cladding with 1/2" (13 mm) vented air space is incorporated into exterior heat transfer coefficient					
10	Wood Buck	5/8" (16)	0.69 (0.10)	-	31 (500)	0.45 (1880)
11	Concrete Slab	8" (203)	12.5 (1.8)	-	140 (2250)	0.20 (850)
12	Structural Thermal Break	2" (51)	0.53 (0.076)	-	-	-
13	#5 Steel Rebar	5/8" (16) Ø	347 (50)	-	489 (7830)	0.12 (500)
14	Wood Liner	1/2" (16)	0.69 (0.10)	-	31 (500)	0.45 (1880)
15	Steel Support Angle	1/4" (6)	430 (62)	-	489 (7830)	0.12 (500)
16	XPS Curb Insulation	2" (51)	0.02 (0.029)	R-10 (1.76 RSI)	1.8 (28)	0.29 (1220)
17	Aluminum Flashing	18 Gauge	1110 (160)	-	171 (2739)	0.22 (900)
18	Concrete Curb	8" (203)	12.5 (1.8)	-	140 (2250)	0.20 (850)
19	Steel Back Angle	18 Gauge	430 (62)	-	489 (7830)	0.12 (500)
20	Wood Sill	1 1/2" (38)	0.69 (0.10)	-	31 (500)	0.45 (1880)
21	3 5/8" x 1 5/8" Steel Studs with Tracks	18 Gauge	430 (62)	-	489 (7830)	0.12 (500)
22	Air in Stud Cavity	3 5/8" (92)	-	R-0.9 (0.16 RSI)	-	0.24 (1000)
23	Gypsum Board	1/2" (13)	1.1 (0.16)	R-0.5 (0.08 RSI)	50 (800)	0.26 (1090)
24	Thermally broken aluminum sliding door ² , double glazed IGU U _{IGU} = 0.32 BTU/hr·ft ² ·°F (1.82 W/m ² K)					
25	Polyamide Shim	1/2" (10)	1.73 (0.25)	-	-	-
26	Exterior Film ¹	-	-	R-0.2 to R-0.7 (0.03 to 0.12 RSI)	-	-

¹ Value selected from table 1, p. 26.1 of 2009 ASHRAE Handbook – Fundamentals depending on surface orientation

²The thermal conductivity of air spaces within framing was found using ISO 100077-2

Detail 9.1.21

Exterior and Interior Insulated 2" x 6" Steel Stud (16" o.c.) Wall Assembly with Vertical Clips (24" o.c.) Supporting Cladding with R-19 Batt in Stud Cavity and Sliding Door – Structural Thermal Break at Concrete Balcony and Curb Intersection

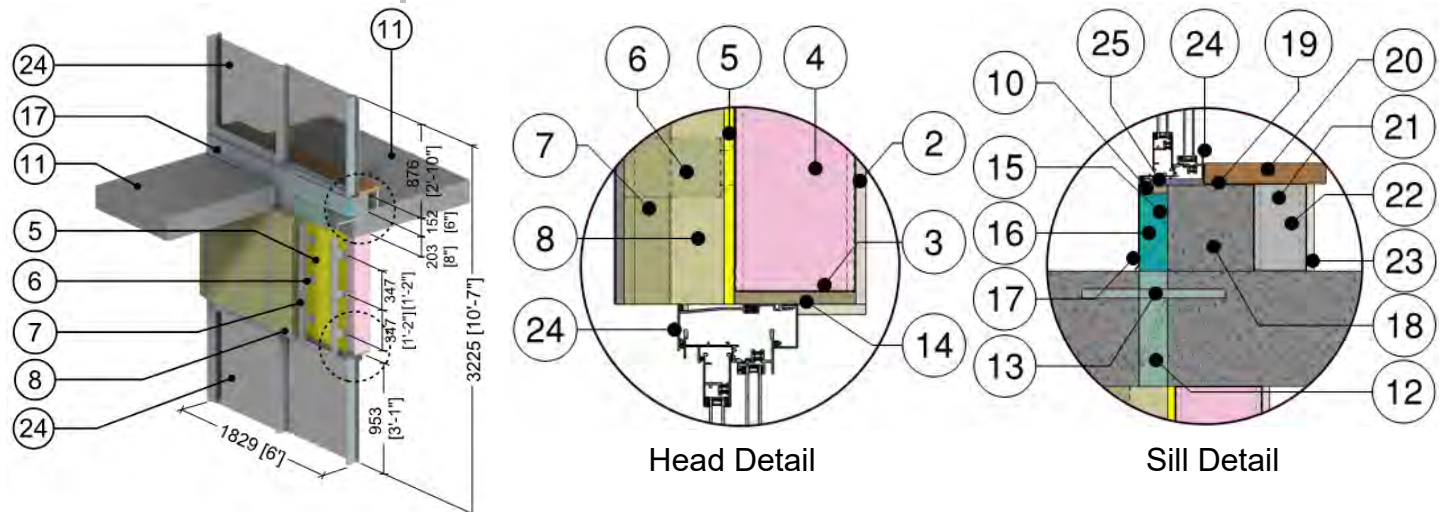

ID	Component	Thickness Inches (mm)	Conductivity Btu-in / ft ² -hr-°F (W/m K)	Nominal Resistance hr-ft ² -°F/Btu (m ² K/W)	Density lb/ft ³ (kg/m ³)	Specific Heat Btu/lb-°F (J/kg K)
1	Interior Film ¹	-	-	R-0.6 to R-1.1 (0.11 to 0.20 RSI)	-	-
2	Gypsum Board	1/2" (13)	1.1 (0.16)	R-0.5 (0.08 RSI)	50 (800)	0.26 (1090)
3	2" x 6" Steel Studs with Tracks	18 Gauge	430 (62)	-	489 (7830)	0.12 (500)
4	Fiberglass Batt Insulation	6" (152)	0.32 (0.046)	R-19 (0.16 RSI)	0.9 (1.4)	0.17 (710)
5	Exterior Sheathing	1/2" (13)	1.1 (0.16)	R-0.5 (0.08 RSI)	50 (800)	0.26 (1090)
6	Thermally Isolated Aluminum Bracket	0.09" (2.2)	-	-	-	-
7	Vertical Aluminum L-girt	0.09" (2.2)	1340 (193)	-	169 (2700)	0.22 (900)
8	Exterior Mineral Wool Insulation	Varies	0.24 (0.034)	R-4.2 to R-21 (0.74 to 3.70 RSI)	-	-
9	Generic Cladding with 1/2" (13 mm) vented air space is incorporated into exterior heat transfer coefficient					
10	Wood Buck	5/8" (16)	0.69 (0.10)	-	31 (500)	0.45 (1880)
11	Concrete Slab	8" (203)	12.5 (1.8)	-	140 (2250)	0.20 (850)
12	Structural Thermal Break	2" (51)	0.53 (0.076)	-	-	-
13	#5 Steel Rebar	5/8" (16) Ø	347 (50)	-	489 (7830)	0.12 (500)
14	Wood Liner	1/2" (16)	0.69 (0.10)	-	31 (500)	0.45 (1880)
15	Steel Support Angle	1/4" (6)	430 (62)	-	489 (7830)	0.12 (500)
16	XPS Curb Insulation	2" (51)	0.02 (0.029)	R-10 (1.76 RSI)	1.8 (28)	0.29 (1220)
17	Aluminum Flashing	18 Gauge	1110 (160)	-	171 (2739)	0.22 (900)
18	Concrete Curb	8" (203)	12.5 (1.8)	-	140 (2250)	0.20 (850)
19	Steel Back Angle	18 Gauge	430 (62)	-	489 (7830)	0.12 (500)
20	Wood Sill	1 1/2" (38)	0.69 (0.10)	-	31 (500)	0.45 (1880)
21	3 5/8" x 1 5/8" Steel Studs with Tracks	18 Gauge	430 (62)	-	489 (7830)	0.12 (500)
22	Air in Stud Cavity	3 5/8" (92)	-	R-0.9 (0.16 RSI)	-	0.24 (1000)
23	Gypsum Board	1/2" (13)	1.1 (0.16)	R-0.5 (0.08 RSI)	50 (800)	0.26 (1090)
24	Thermally broken aluminum sliding door ² , double glazed IGU U _{IGU} = 0.32 BTU/hr-ft ² -°F (1.82 W/m ² K)					
25	Polyamide Shim	1/2" (10)	1.73 (0.25)	-	-	-
26	Exterior Film ¹	-	-	R-0.2 to R-0.7 (0.03 to 0.12 RSI)	-	-

¹ Value selected from table 1, p. 26.1 of 2009 ASHRAE Handbook – Fundamentals depending on surface orientation

²The thermal conductivity of air spaces within framing was found using ISO 100077-2

10.0 Roofs

Detail 10.1.1	A.10.1
Exterior Insulated Sloped Metal Roof with Metal Sub-Girts (12" o.c.) Supporting Standing Seam Metal Roof – Clear Roof	
Detail 10.1.2	A.10.2
Exterior Insulated Sloped Metal Roof with Metal Sub-Girts (24" o.c.) Supporting Standing Seam Metal Roof – Clear Roof	
Detail 10.1.3	A.10.3
Exterior Insulated Sloped Metal Roof with Metal Sub-Girts (36" o.c.) Supporting Standing Seam Metal Roof – Clear Roof	
Detail 10.1.4	A.10.4
Insulated Sheet Steel Roof Supported by Thermal Chairs – Baseline System – Clear Roof	
Detail 10.1.5	A.10.5
Insulated Sheet Steel Roof Supported by Thermal Chairs – Additional Scenarios – Clear Roof	
Detail 10.1.6	A.10.6
Insulated Sheet Steel Roof Supported by Thermal Chairs – Additional Insulation Type Scenarios – Clear Roof	
Detail 10.1.7	A.10.7
Insulated Standing Seam Roof Supported by Thermal Chairs – Clear Wall	
Detail 10.1.8	A.10.8
Standing Seam Roof with Draped Insulation – Clear Wall	
Detail 10.1.9	A.10.9
Exterior Insulated Low Sloped Roof (3.4 fasteners/m ² , 0.3 fasteners/ft ²)– Clear Roof Assembly	
Detail 10.1.10	A.10.10
Exterior Insulated Sloped Metal Roof with Polyisocyanurate Insulation and Bearing Plates 18" x 48" spacing – Clear Roof Assembly	
Detail 10.1.11	A.10.11
Exterior Insulated Sloped Metal Roof with High Compressive Strength Mineral Wool Insulation and Bearing Plates 18" x 48" spacing – Clear Roof Assembly	
Detail 10.1.12	A.10.12
Ventilated Wood Frame Low Sloped Roof – Clear Roof Assembly	
Detail 10.1.13	A.10.13
Exterior Insulated Low Sloped Roof (10.8 fasteners/m ² , 1 fasteners/ft ²) – Clear Roof Assembly	
Detail 10.1.14	A.10.14
Sloped Wood Framed Roof with Insulation at Ceiling	

Detail 10.1.15	A.10.15
Sloped Wood Framed Roof with Insulation at Roof Sheathing	
Detail 10.1.16	A.10.16
Exterior Insulated Low Sloped Roof with Fully Adhered Roof Membrane and Mineral Wool Insulation – Clear Roof Assembly	
Detail 10.1.17	A.10.17
Exterior Insulated Low Sloped Roof with Fully Adhered Roof Membrane and Mineral Wool and Polyisocyanurate Insulation – Clear Roof Assembly	
Detail 10.2.1	A.10.18
Exterior Insulated Sloped Metal Roof with Metal Sub-Girts (24" o.c.) Supporting Metal Roof – Ridge Intersection	
Detail 10.2.2	A.10.19
Insulated Concrete Slab – Concrete Curb or Wall Intersection	
Detail 10.2.3	A.10.20
Owens Corning Insulated Projected Membrane Roof – Floating Concrete Wall Intersection	
Detail 10.2.4	A.10.21
Exterior Insulated Sloped Metal Roof with Metal Sub-Girts (24" o.c.) Supporting Standing Seam Metal Roof and Curtain Wall – Roof to Wall Intersection with Through Wall Structural Beam and Continuous Through Wall Structural Metal Deck	
Detail 10.2.5	A.10.22
Exterior Insulated Sloped Metal Roof with Metal Sub-Girts (24" o.c.) Supporting Standing Seam Metal Roof and Curtain Wall – Roof to Wall Intersection with Through Wall Structural Beam and Thermally Broken Structural Metal Deck	
Detail 10.2.6	A.10.23
Exterior Insulated Sloped Metal Roof with Metal Sub-Girts (24" o.c.) Supporting Standing Seam Metal Roof and Curtain Wall – Roof to Wall Intersection with Through Wall Structural Beam and Fully Insulated Soffit	
Detail 10.2.7	A.10.24
Aluminum Framed Double Glazed Skylight – Exterior Insulated Concrete Curb Intersection	
Detail 10.3.1	A.10.25
Exterior Insulated Conventional Flat Roof – Roof Anchor	
Detail 10.3.2	A.10.26
Exterior Insulated Conventional Flat Roof – Armatherm Thermal Break under Roof Anchor	
Detail 10.3.3	A.10.27
Exterior Insulated Conventional Low-Sloped Roof – Roof Anchor	

Detail 10.3.4**A.10.28**
Exterior Insulated Conventional Low-Sloped Roof – Thermal Break in Roof Anchor

Detail 10.4.1**A.10.29**
Exterior Insulated Low Sloped Roof with Fully Adhered Roof Membrane and Mineral Wool Insulation - Flange-Style Drain Penetration

Detail 10.4.2**A.10.30**
Exterior Insulated Low Sloped Roof with Fully Adhered Roof Membrane and Mineral Wool and Polyisocyanurate Insulation - Flange-Style Drain Penetration

Detail 10.1.1

Exterior Insulated Sloped Metal Roof with Metal Sub-Girts (12" o.c.) Supporting Standing Seam Metal Roof – Clear Roof

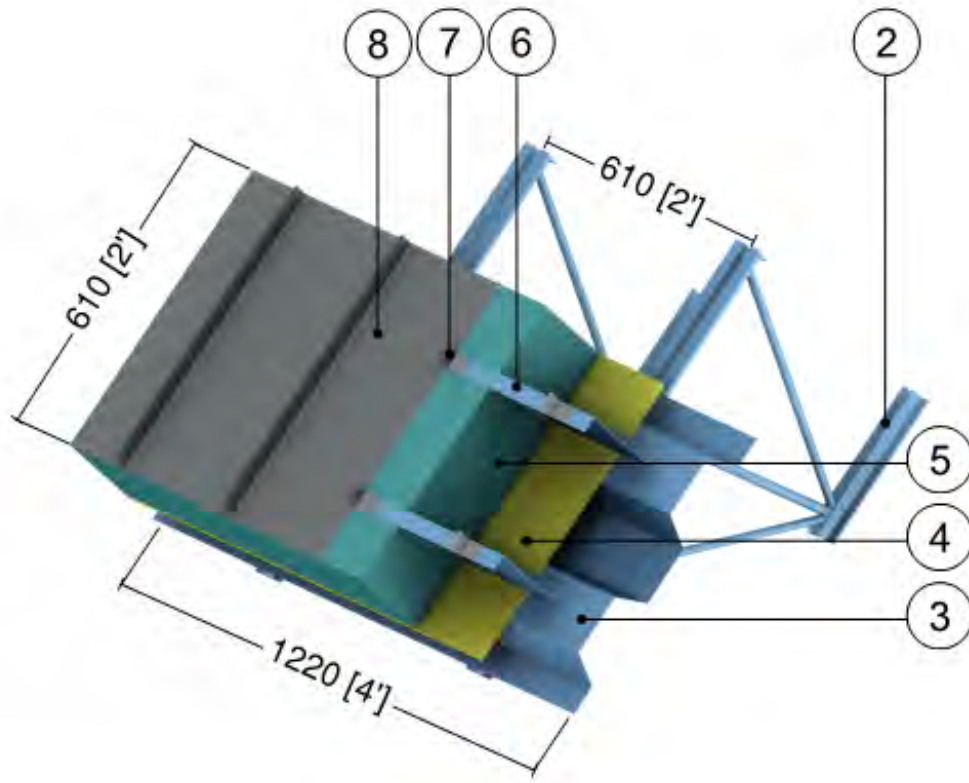

ID	Component	Thickness Inches (mm)	Conductivity Btu·in / ft ² ·hr·°F (W/m K)	Nominal Resistance hr·ft ² ·°F/Btu (m ² K/W)	Density lb/ft ³ (kg/m ³)	Specific Heat Btu/lb·°F (J/kg K)
1	Interior Film ¹	-	-	R-1.1 (0.20 RSI)	-	-
2	Open Web Steel Joist (550C) @ 24" (610) o.c.	-	347 (50)	-	489 (7830)	0.12 (500)
3	Steel Deck	1/16" (1.6)	347 (50)	-	489 (7830)	0.12 (500)
4	Roof Sheathing	1/2" (13)	1.1 (0.16)	R-0.5 (0.08 RSI)	50 (800)	0.26 (1090)
5	Rigid Roof Insulation	Varies	-	R-20 to R-40 (3.52 RSI to 7.04 RSI)	1.8 (28)	0.29 (1220)
6	Sub-Girt with 1 1/2" Flange @ 12" (305) o.c.	16 Gauge	430 (62)	-	489 (7830)	0.12 (500)
7	Roof Clip (1 1/2" x 1 1/2")	16 Gauge	430 (62)	-	489 (7830)	0.12 (500)
8	Metal Roof	24 Gauge	430 (62)	-	489 (7830)	0.12 (500)
9	Exterior Film ¹	-	-	R-0.2 (0.03 RSI)	-	-

¹ Value selected from table 1, p. 26.1 of 2009 ASHRAE Handbook – Fundamentals depending on surface orientation

Detail 10.1.2

Exterior Insulated Sloped Metal Roof with Metal Sub-Girts (24" o.c.) Supporting Standing Seam Metal Roof – Clear Roof

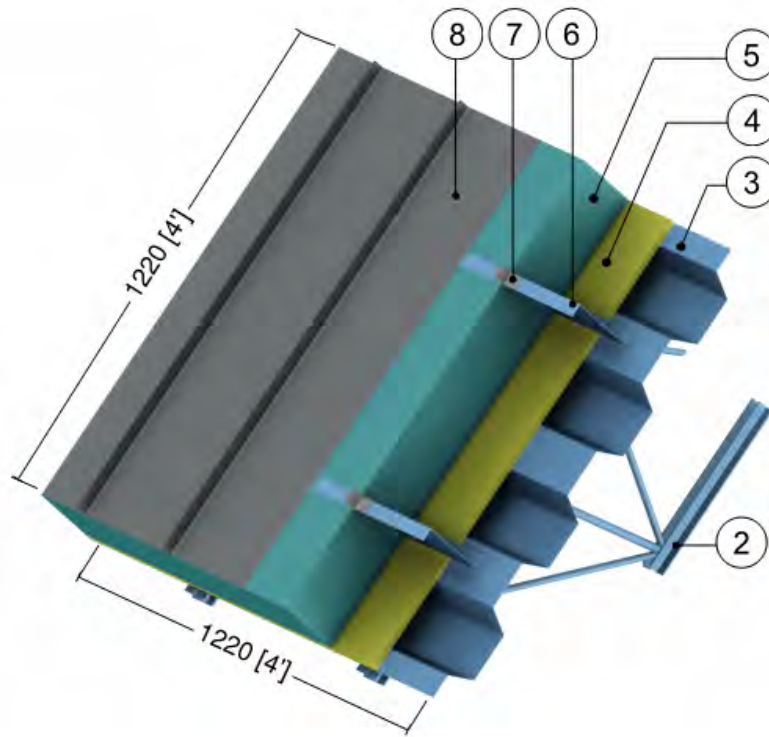

ID	Component	Thickness Inches (mm)	Conductivity Btu·in / ft ² ·hr·°F (W/m K)	Nominal Resistance hr·ft ² ·°F/Btu (m ² K/W)	Density lb/ft ³ (kg/m ³)	Specific Heat Btu/lb·°F (J/kg K)
1	Interior Film ¹	-	-	R-1.1 (0.20 RSI)	-	-
2	Open Web Steel Joist (550C) @ 24" (610) o.c.	-	347 (50)	-	489 (7830)	0.12 (500)
3	Steel Deck	1/16" (1.6)	347 (50)	-	489 (7830)	0.12 (500)
4	Roof Sheathing	1/2" (13)	1.1 (0.16)	R-0.5 (0.08 RSI)	50 (800)	0.26 (1090)
5	Rigid Roof Insulation	Varies	-	R-20 to R-40 (3.52 RSI to 7.04 RSI)	1.8 (28)	0.29 (1220)
6	Sub-Girt with 1 1/2" Flange @ 24" (610) o.c.	16 Gauge	430 (62)	-	489 (7830)	0.12 (500)
7	Roof Clip (1 1/2" x 1 1/2")	16 Gauge	430 (62)	-	489 (7830)	0.12 (500)
8	Metal Roof	24 Gauge	430 (62)	-	489 (7830)	0.12 (500)
9	Exterior Film ¹	-	-	R-0.2 (0.03 RSI)	-	-

¹ Value selected from table 1, p. 26.1 of 2009 ASHRAE Handbook – Fundamentals depending on surface orientation

Detail 10.1.3

Exterior Insulated Sloped Metal Roof with Metal Sub-Girts (36" o.c.) Supporting Standing Seam Metal Roof – Clear Roof

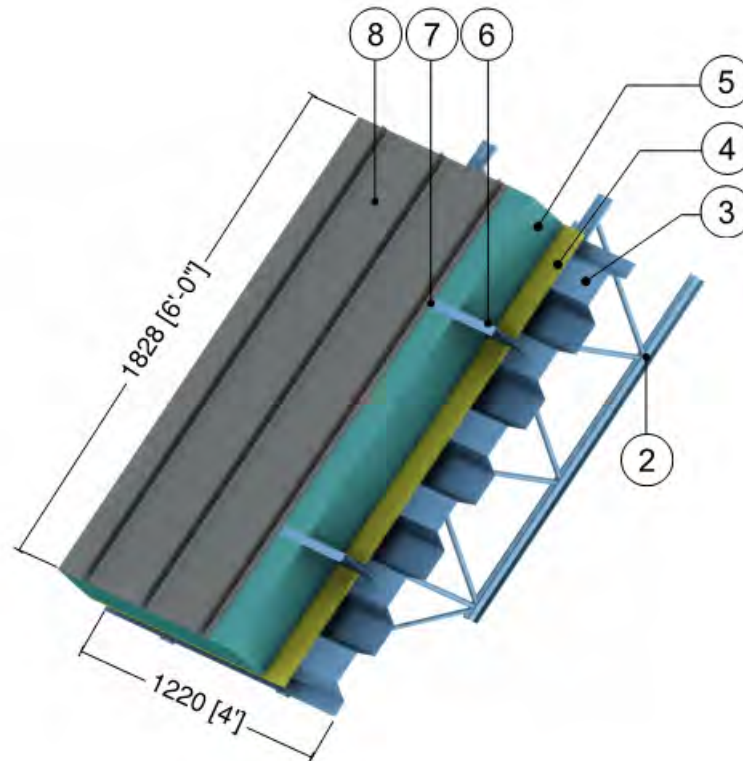

ID	Component	Thickness Inches (mm)	Conductivity Btu-in / ft ² ·hr·°F (W/m K)	Nominal Resistance hr·ft ² ·°F/Btu (m ² K/W)	Density lb/ft ³ (kg/m ³)	Specific Heat Btu/lb·°F (J/kg K)
1	Interior Film ¹	-	-	R-1.1 (0.20 RSI)	-	-
2	Open Web Steel Joist (550C)@ 24" (610) o.c.	-	347 (50)	-	489 (7830)	0.12 (500)
3	Steel Deck	1/16" (1.6)	347 (50)	-	489 (7830)	0.12 (500)
4	Roof Sheathing	1/2" (13)	1.1 (0.16)	R-0.5 (0.08 RSI)	50 (800)	0.26 (1090)
5	Rigid Roof Insulation	Varies	-	R-20 to R-40 (3.52 RSI to 7.04 RSI)	1.8 (28)	0.29 (1220)
6	Sub-Girt with 1 1/2" Flange @ 36" (914) o.c.	16 Gauge	430 (62)	-	489 (7830)	0.12 (500)
7	Roof Clips (1 1/2" x 1 1/2")	16 Gauge	430 (62)	-	489 (7830)	0.12 (500)
8	Metal Roof	24 Gauge	430 (62)	-	489 (7830)	0.12 (500)
9	Exterior Film ¹	-	-	R-0.2 (0.03 RSI)	-	-

¹ Value selected from table 1, p. 26.1 of 2009 ASHRAE Handbook – Fundamentals depending on surface orientation

Detail 10.1.4 Insulated Sheet Steel Roof Supported by Thermal Chairs – Baseline System – Clear Roof

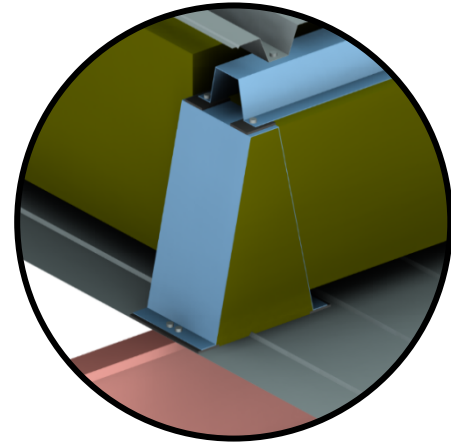
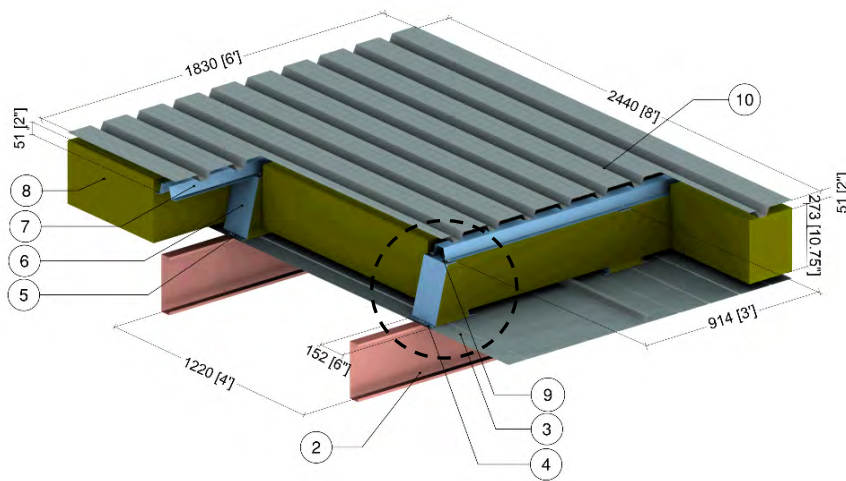

Bracket Detail

ID	Component	Thickness Inches (mm)	Conductivity Btu-in / ft ² ·hr·°F (W/m K)	Nominal Resistance hr·ft ² ·°F/Btu (m ² K/W)	Density lb/ft ³ (kg/m ³)	Specific Heat Btu/lb·°F (J/kg K)
1	Interior Films ¹	-	-	R-1.1 (0.20 RSI)	-	-
2	10 x 2 Galvanized Steel Purlin @ 48" o.c.	1/10" (2.6)	430 (62)	-	489 (7830)	0.12 (500)
3	Galvanized Steel Liner	24 Gauge	430 (62)	-	489 (7830)	0.12 (500)
4	Thermal Tape	1/8" (3.18)	0.097 (0.014)	-	-	-
5	#12 Steel Fasteners	0.22" (5.50) ∅	430 (62)	-	489 (7830)	0.12 (500)
6	10-in Galvanized Steel Hat Section (Thermal Chair)	18 Gauge	430 (62)	-	489 (7830)	0.12 (500)
7	2-in Galvanized Steel Hat Section (Outer Rail)	18 Gauge	430 (62)	-	489 (7830)	0.12 (500)
8	Mineral Wool Insulation	10 3/4" (273)	0.240 (0.034)	R-45 (7.93 RSI)	1.8 (28)	0.29 (1090)
9	Air Gap ²	-	Varies	-	0.075 (1.2)	0.24 (1000)
10	Galvanized Steel Cladding	22 Gauge	430 (62)	-	489 (7830)	0.12 (500)
11	Exterior Film ¹	-	-	R-0.2 (0.03 RSI)	-	-

¹ Value selected from table 1, p. 26.1 of 2009 ASHRAE Handbook – Fundamentals depending on surface orientation

² The thermal conductivity of air spaces was found using ISO 100077-2

Detail 10.1.5 Insulated Sheet Steel Roof Supported by Thermal Chairs – Additional Scenarios – Clear Roof

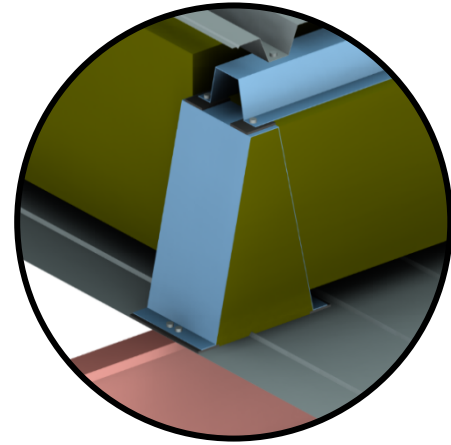
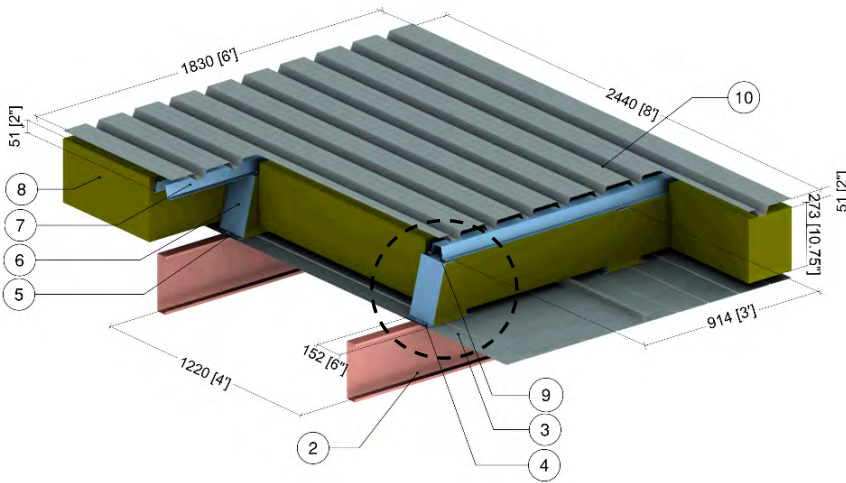

Bracket Detail

ID	Component	Thickness Inches (mm)	Conductivity Btu-in / ft ² ·hr·°F (W/m K)	Nominal Resistance hr·ft ² ·°F/Btu (m ² K/W)	Density lb/ft ³ (kg/m ³)	Specific Heat Btu/lb·°F (J/kg K)
1	Interior Films (left side) ¹	-	-	R-1.1 (0.20 RSI)	-	-
2	10 x 2 Galvanized Steel Purlin @ 48" o.c.	1/10" (2.6)	430 (62)	-	489 (7830)	0.12 (500)
3	Galvanized Steel Liner	24 Gauge	430 (62)	-	489 (7830)	0.12 (500)
4	Thermal Tape	1/8" (3.18)	0.097 (0.014)	-	-	-
5	#12 Steel Fasteners	0.22" (5.50) ∅	430 (62)	-	489 (7830)	0.12 (500)
6	10-in Galvanized Steel Hat Section (Thermal Chair)	18 Gauge	430 (62)	-	489 (7830)	0.12 (500)
7	2-in Galvanized Steel Hat Section (Outer Rail)	18 Gauge	430 (62)	-	489 (7830)	0.12 (500)
8	Mineral Wool Insulation	10 3/4" (273)	0.240 (0.034)	R-45 (7.93 RSI)	1.8 (28)	0.29 (1090)
9	Air Gap ²	-	Varies	-	0.075 (1.2)	0.24 (1000)
10	Galvanized Steel Cladding	22 Gauge	430 (62)	-	489 (7830)	0.12 (500)
11	Exterior Film (right side) ¹	-	-	R-0.2 (0.03 RSI)	-	-

¹ Value selected from table 1, p. 26.1 of 2009 ASHRAE Handbook – Fundamentals depending on surface orientation

² The thermal conductivity of air spaces was found using ISO 100077-2

Detail 10.1.6 Insulated Sheet Steel Roof Supported by Thermal Chairs – Additional Insulation Type Scenarios – Clear Roof

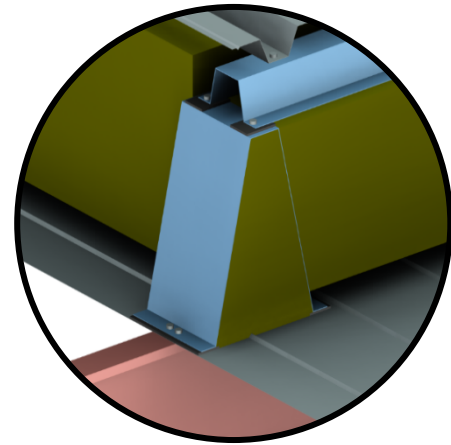
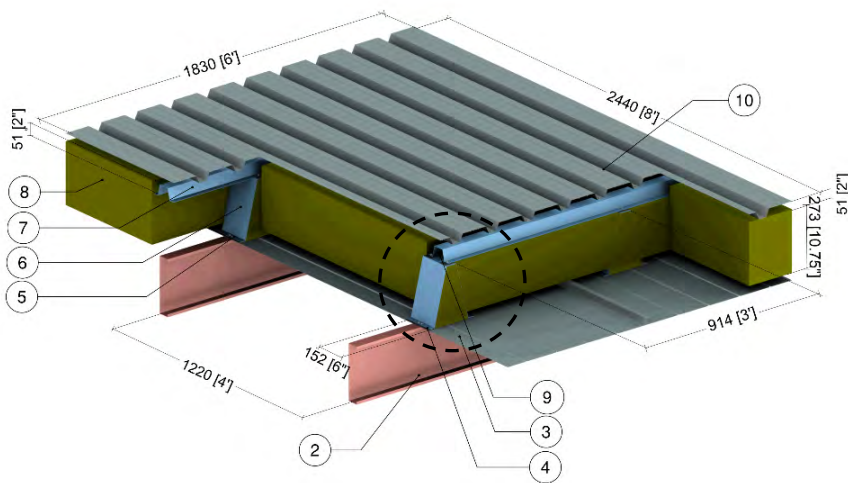

Bracket Detail

ID	Component	Thickness Inches (mm)	Conductivity Btu-in / ft ² ·hr·°F (W/m K)	Nominal Resistance hr·ft ² ·°F/Btu (m ² K/W)	Density lb/ft ³ (kg/m ³)	Specific Heat Btu/lb·°F (J/kg K)
1	Interior Films (left side) ¹	-	-	R-1.1 (0.20 RSI)	-	-
2	10 x 2 Galvanized Steel Purlin @ 48" o.c.	1/10" (2.6)	430 (62)	-	489 (7830)	0.12 (500)
3	Galvanized Steel Liner	24 Gauge	430 (62)	-	489 (7830)	0.12 (500)
4	Thermal Tape	1/8" (3.18)	0.097 (0.014)	-	-	-
5	#12 Steel Fasteners	0.22" (5.50) ∅	430 (62)	-	489 (7830)	0.12 (500)
6	10-in Galvanized Steel Hat Section (Thermal Chair)	18 Gauge	430 (62)	-	489 (7830)	0.12 (500)
7	2-in Galvanized Steel Hat Section (Outer Rail)	18 Gauge	430 (62)	-	489 (7830)	0.12 (500)
8	Mineral Wool Insulation	10 3/4" (273)	0.240 (0.034)	R-45 (7.93 RSI)	1.8 (28)	0.29 (1090)
9	Air Gap ²	-	Varies	-	0.075 (1.2)	0.24 (1000)
10	Galvanized Steel Cladding	22 Gauge	430 (62)	-	489 (7830)	0.12 (500)
11	Exterior Film (right side) ¹	-	-	R-0.2 (0.03 RSI)	-	-

¹ Value selected from table 1, p. 26.1 of 2009 ASHRAE Handbook – Fundamentals depending on surface orientation

² The thermal conductivity of air spaces was found using ISO 100077-2

Detail 10.1.7 Insulated Standing Seam Roof Supported by Thermal Chairs – Clear Wall

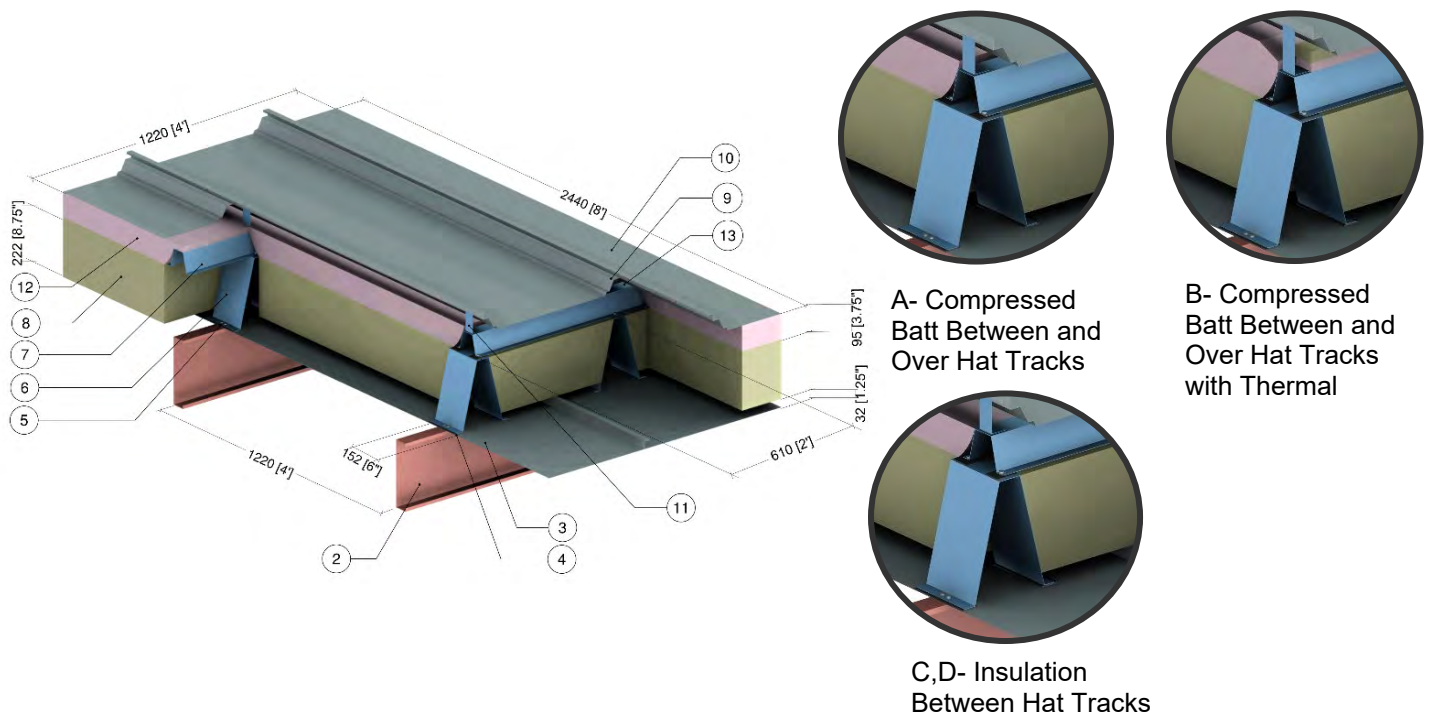

ID	Component	Thickness Inches (mm)	Conductivity Btu-in / ft ² ·hr·°F (W/m K)	Nominal Resistance hr·ft ² ·°F/Btu (m ² K/W)	Density lb/ft ³ (kg/m ³)	Specific Heat Btu/lb·°F (J/kg K)
1	Interior Films (left side) ¹	-	-	R-1.1 (0.20 RSI)	-	-
2	10 x 2 Galvanized Steel Purlin @ 48" o.c.	1/10" (2.6)	430 (62)	-	489 (7830)	0.12 (500)
3	Galvanized Steel Liner	24 Gauge	430 (62)	-	489 (7830)	0.12 (500)
4	Thermal Tape	1/8" (3.18)	0.097 (0.014)	-	-	-
5	#12 Steel Fasteners	0.22" (5.50) ∅	430 (62)	-	489 (7830)	0.12 (500)
6	10-in Galvanized Steel Hat Section (Thermal Chair)	18 Gauge	430 (62)	-	489 (7830)	0.12 (500)
7	2-in Galvanized Steel Hat Section (Outer Rail)	18 Gauge	430 (62)	-	489 (7830)	0.12 (500)
8	Mineral Wool Insulation	10 3/4" (273)	0.240 (0.034)	R-45 (7.93 RSI)	1.8 (28)	0.29 (1090)
9	Air Gap ²	-	Varies	-	0.075 (1.2)	0.24 (1000)
10	Galvanized Steel Cladding	22 Gauge	430 (62)	-	489 (7830)	0.12 (500)
11	Steel Clips	18 Gauge	430 (62)	-	489 (7830)	0.12 (500)
12	Fiberglass Batt Insulation	6" (152)	0.30 (0.043)	R-19 (3.35 RSI)	0.9 (14)	0.17 (710)
13	Thermal Block	1" (25)	0.20 (0.029)	R-5 (0.88 RSI)	9.4 (150)	0.23 (1000)
14	Exterior Film (right side) ¹	-	-	R-0.2 (0.03 RSI)	-	-

¹ Value selected from table 1, p. 26.1 of 2009 ASHRAE Handbook – Fundamentals depending on surface orientation

² The thermal conductivity of air spaces was found using ISO 10077-2

Detail 10.1.8 | Standing Seam Roof with Draped Insulation – Clear Wall

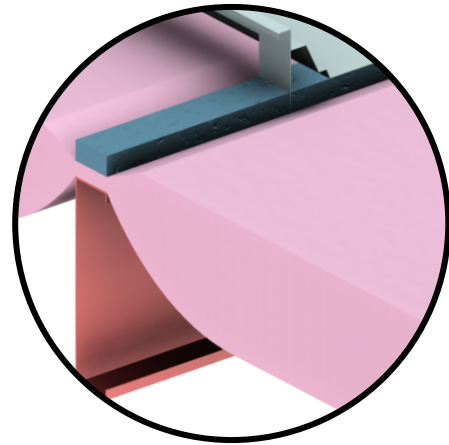
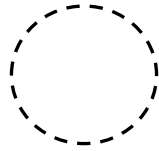

Bracket Detail

ID	Component	Thickness Inches (mm)	Conductivity Btu-in / ft ² ·hr·°F (W/m K)	Nominal Resistance hr·ft ² ·°F/Btu (m ² K/W)	Density lb/ft ³ (kg/m ³)	Specific Heat Btu/lb·°F (J/kg K)
1	Interior Films (left side) ¹	-	-	R-0.6 (0.11 RSI)	-	-
2	10 x 2 Galvanized Steel Purlin @ 48" o.c.	1/10" (2.6)	430 (62)	-	489 (7830)	0.12 (500)
3	Air Gap ²	-	Varies	-	0.075 (1.2)	0.24 (1000)
4	Galvanized Steel Cladding	22 Gauge	430 (62)	-	489 (7830)	0.12 (500)
5	Steel Clips	18 Gauge	430 (62)	-	489 (7830)	0.12 (500)
6	Fiberglass Batt Insulation	6" (152)	0.30 (0.043)	R-19 (3.35 RSI)	0.9 (14)	0.17 (710)
7	Thermal Block	1" (25)	0.20 (0.029)	R-5 (0.88 RSI)	9.4 (150)	0.23 (1000)
8	Exterior Film (right side) ¹	-	-	R-0.2 (0.03 RSI)	-	-

¹ Value selected from table 1, p. 26.1 of 2009 ASHRAE Handbook – Fundamentals depending on surface orientation

² The thermal conductivity of air spaces was found using ISO 100077-2

Detail 10.1.9

Exterior Insulated Low Sloped Roof (3.4 fasteners/m², 0.3 fasteners/ft²)– Clear Roof Assembly

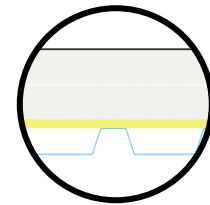
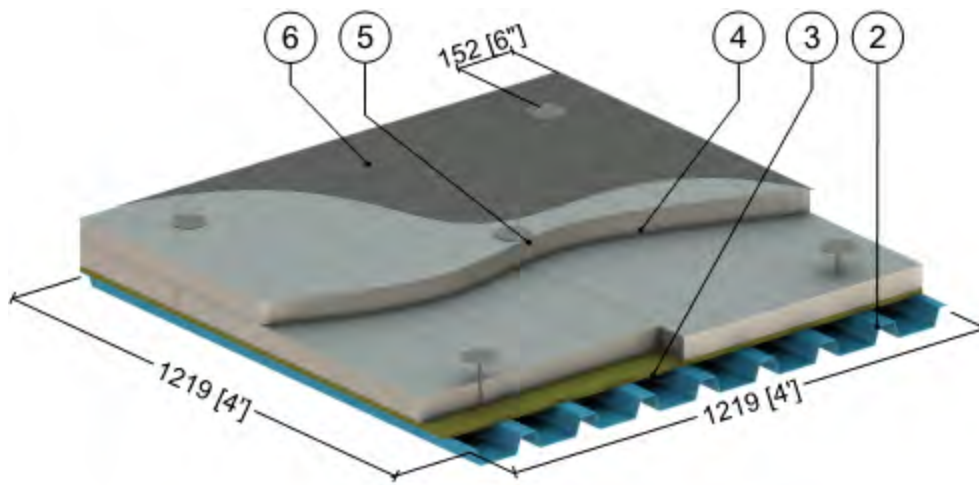

Fully Adhered

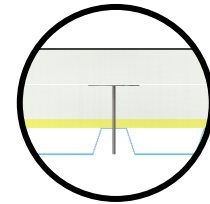

Partially Fastened

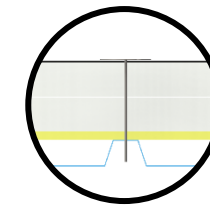

Fully Fastened

ID	Component	Thickness Inches (mm)	Conductivity Btu·in / ft ² ·hr·°F (W/m K)	Nominal Resistance hr·ft ² ·°F/Btu (m ² K/W)	Density lb/ft ³ (kg/m ³)	Specific Heat Btu/lb·°F (J/kg K)
1	Interior Films ¹	-	-	R-1.1 (0.19 RSI)	-	-
2	Steel Deck	1/16" (1.6)	430 (62)	-	489 (7830)	0.12 (500)
3	Sheathing	1/2" (13)	1.1 (0.16)	R-0.5 (0.08 RSI)	50 (800)	0.26 (1090)
4	2 Layer Polyisocyanurate Insulation	Varies	Varies	R-22.8 to R-39.9 (4.02 to 7.03 RSI)	1.8 (28)	0.29 (1220)
5	#10 or #14 Steel Fasteners	3/16" (4.8) Ø, 1/4" (6.1) Ø	430 (62)	-	489 (7830)	0.12 (500)
6	Asphalt Cover Board and Roof Membrane	1/2" (12)	3 (0.43)	R-0.2 (0.03 RSI)	100 (1600)	100 (1500)
7	Exterior Film ¹	-	-	R-0.2 (0.03 RSI)	-	-

¹ Value selected from table 1, p. 26.1 of 2009 ASHRAE Handbook – Fundamentals depending on surface orientation

Detail 10.1.10 Exterior Insulated Sloped Metal Roof with Polyisocyanurate Insulation and Bearing Plates 18" x 48" spacing – Clear Roof Assembly

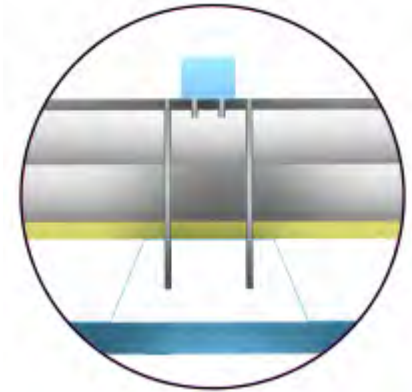
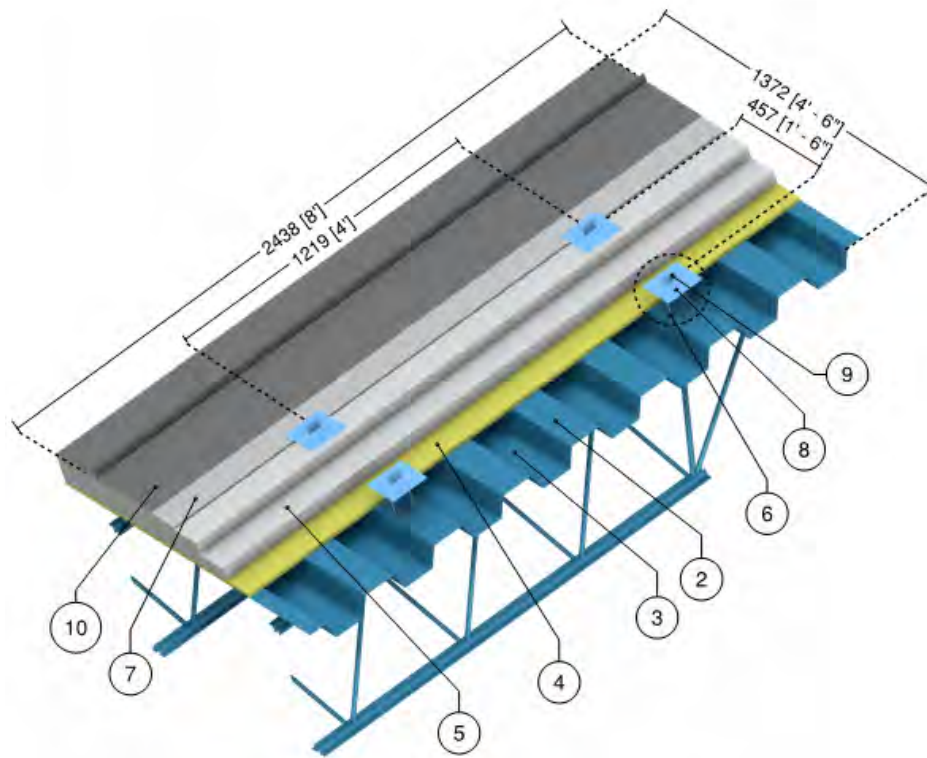

Bearing Plate and Clip Detail

ID	Component	Thickness Inches (mm)	Conductivity Btu-in / ft ² ·hr·°F (W/m K)	Nominal Resistance hr·ft ² ·°F/Btu (m ² K/W)	Density lb/ft ³ (kg/m ³)	Specific Heat Btu/lb·°F (J/kg K)
1	Interior Films ¹	-	-	R-1.1 (0.2 RSI)	-	-
2	Steel Deck	1/16" (1.6)	347 (50)	-	489 (7830)	0.12 (500)
3	Air in Steel Deck Flute ²	3" (76)	0.87 (0.13)	R-3.5 (0.6 RSI)	0.075 (1.2)	0.24 (1000)
4	Gypsum Board	5/8" (16)	1.11 (0.16)	R-0.6 (0.1 RSI)	50 (800)	0.26 (1090)
5	2 Layer Polyisocyanurate Insulation	Varies	0.18 (0.025)	R-22.8 to R-45.6 (4.02 RSI to 8.03 RSI)	1.8 (28)	0.29 (1220)
6	#14 Steel Fasteners	1/4" (6.1) ∅	347 (50)	-	489 (7830)	0.12 (500)
7	Polyisocyanurate Cover Board	1/2" (12)	0.18 (0.025)	R-2.9 (0.5 RSI)	1.8 (28)	100 (1500)
8	Galvanized Steel Bearing Plates	24 Gauge	430 (62)	-	489 (7830)	0.12 (500)
9	Roof Panel Clip (1 1/2" x 3/4")	24 Gauge	430 (62)	-	489 (7830)	0.12 (500)
10	Standing Seam Roof Panel	24 Gauge	430 (62)	-	489 (7830)	0.12 (500)
11	Exterior Film ¹	-	-	R-0.2 (0.03 RSI)	-	-

¹ Value selected from table 1, p. 26.1 of 2009 ASHRAE Handbook – Fundamentals depending on surface orientation

² The thermal conductivity of air spaces within the assembly was found using ISO 100077-2

Detail 10.1.11

Exterior Insulated Sloped Metal Roof with High Compressive Strength Mineral Wool Insulation and Bearing Plates 18" x 48" spacing – Clear Roof Assembly

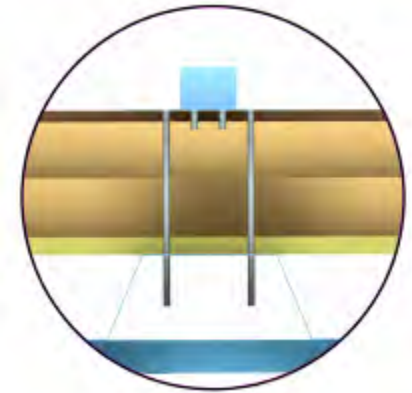
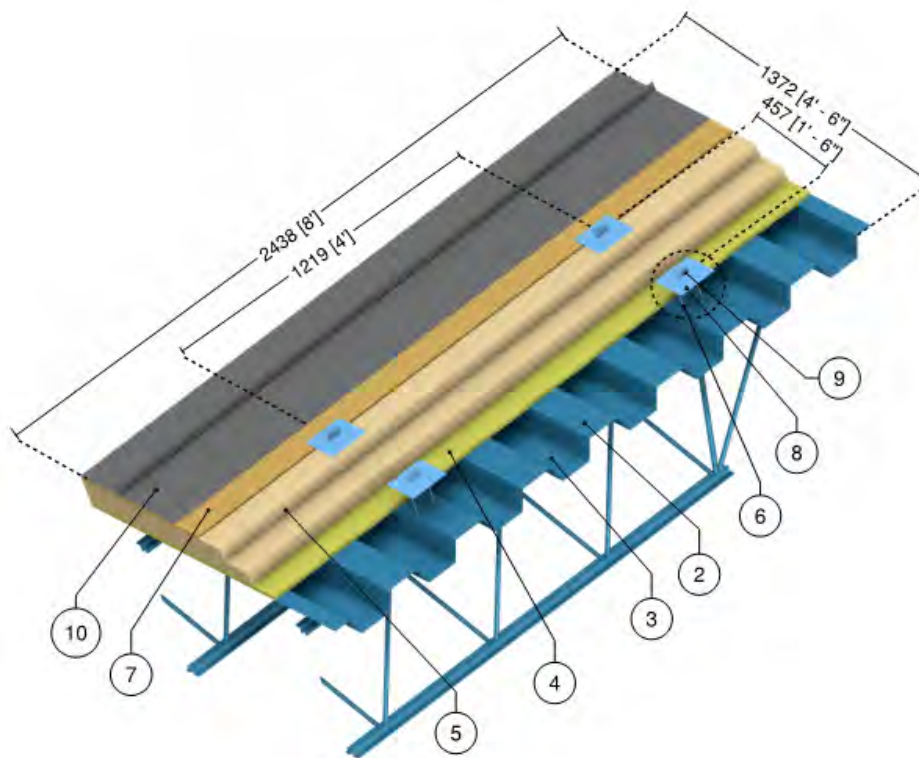

Bearing Plate and Clip Detail

ID	Component	Thickness Inches (mm)	Conductivity Btu-in / ft ² ·hr·°F (W/m K)	Nominal Resistance hr·ft ² ·°F/Btu (m ² K/W)	Density lb/ft ³ (kg/m ³)	Specific Heat Btu/lb·°F (J/kg K)
1	Interior Films ¹	-	-	R-1.1 (0.2 RSI)	-	-
2	Steel Deck	1/16" (1.6)	347 (50)	-	489 (7830)	0.12 (500)
3	Air in Steel Deck Flute ²	3" (76)	0.87 (0.13)	R-3.5 (0.6 RSI)	0.075 (1.2)	0.24 (1000)
4	Gypsum Board	5/8" (16)	1.1 (0.16)	R-0.6 (0.1 RSI)	50 (800)	0.26 (1090)
5	High Compressive Strength Mineral Wool Insulation	Varies	0.26 (0.038)	R-15.2 to R-30.4 (2.68 RSI to 5.35 RSI)	9 (150)	0.29 (1220)
6	#14 Steel Fasteners	1/4" (6.1) ∅	347 (50)	-	489 (7830)	0.12 (500)
7	Insulating cover board	1/2" (12)	0.26 (0.038)	R-1.9 (0.33 RSI)	14 (220)	0.29 (1220)
8	Galvanized Steel Bearing Plates	24 Gauge	430 (62)	-	489 (7830)	0.12 (500)
9	Roof Panel Clip (1 1/2" x 3/4")	24 Gauge	430 (62)	-	489 (7830)	0.12 (500)
10	Standing Seam Roof Panel	24 Gauge	430 (62)	-	489 (7830)	0.12 (500)
11	Exterior Film ¹	-	-	R-0.2 (0.03 RSI)	-	-

¹ Value selected from table 1, p. 26.1 of 2009 ASHRAE Handbook – Fundamentals depending on surface orientation

² The thermal conductivity of air spaces within the assembly was found using ISO 100077-2

Detail 10.1.12 | Ventilated Wood Frame Low Sloped Roof – Clear Roof Assembly

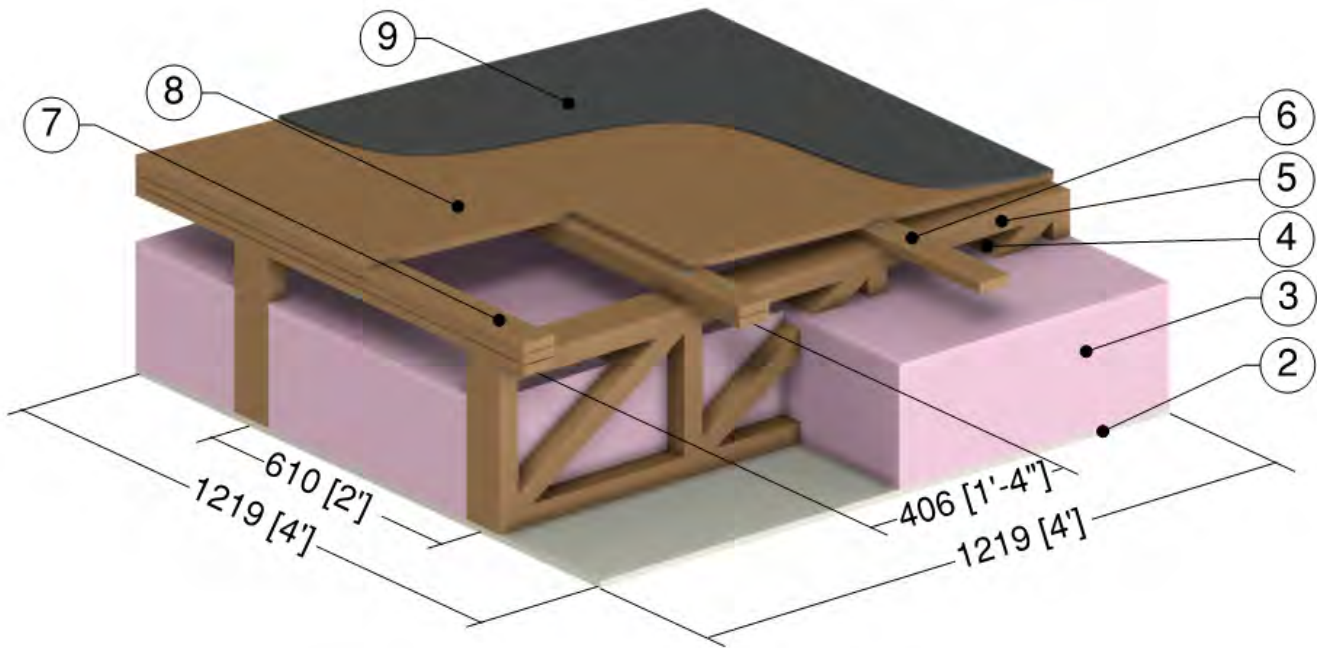

ID	Component	Thickness Inches (mm)	Conductivity Btu·in / ft ² ·hr·°F (W/m K)	Nominal Resistance hr·ft ² ·°F/Btu (m ² K/W)	Density lb/ft ³ (kg/m ³)	Specific Heat Btu/lb·°F (J/kg K)
1	Interior Film ¹	-	-	R-0.6 (0.11 RSI)	-	-
2	Gypsum Board	1/2" (13)	1.1 (0.16)	R-0.5 (0.08 RSI)	50 (800)	0.26 (1090)
3	Roof Insulation	Varies	-	R-20 to R-40 (3.52 RSI to 7.04 RSI)	0.9 (14)	0.17 (710)
4	Air Cavity	Varies	-	R-0.9 (0.16 RSI)	0.075 (1.2)	0.24 (1000)
5	2x4 Parallel Wood Truss (24" o.c.)	-	0.69 (0.10)	-	31 (500)	0.45 (1880)
6	Wood Purlins (16" o.c.)	-	0.69 (0.10)	-	31 (500)	0.45 (1880)
7	Fasteners	0.44" (11) Ø	430 (62)	-	489 (7830)	0.12 (500)
8	Roof Wood Sheathing	1/2" (13)	0.69 (0.10)	R-0.7 (0.13 RSI)	50 (800)	0.26 (1090)
9	Roof Cover	1/4" (6.3)	1.1 (0.16)	R-0.2 (0.04 RSI)	50 (800)	0.26 (1090)
10	Exterior Film ¹	-	-	R-0.2 (0.03 RSI)	-	-

¹ Value selected from table 1, p. 26.1 of 2009 ASHRAE Handbook – Fundamentals depending on surface orientation

Detail 10.1.13

Exterior Insulated Low Sloped Roof (10.8 fasteners/m², 1 fasteners/ft²) – Clear Roof Assembly

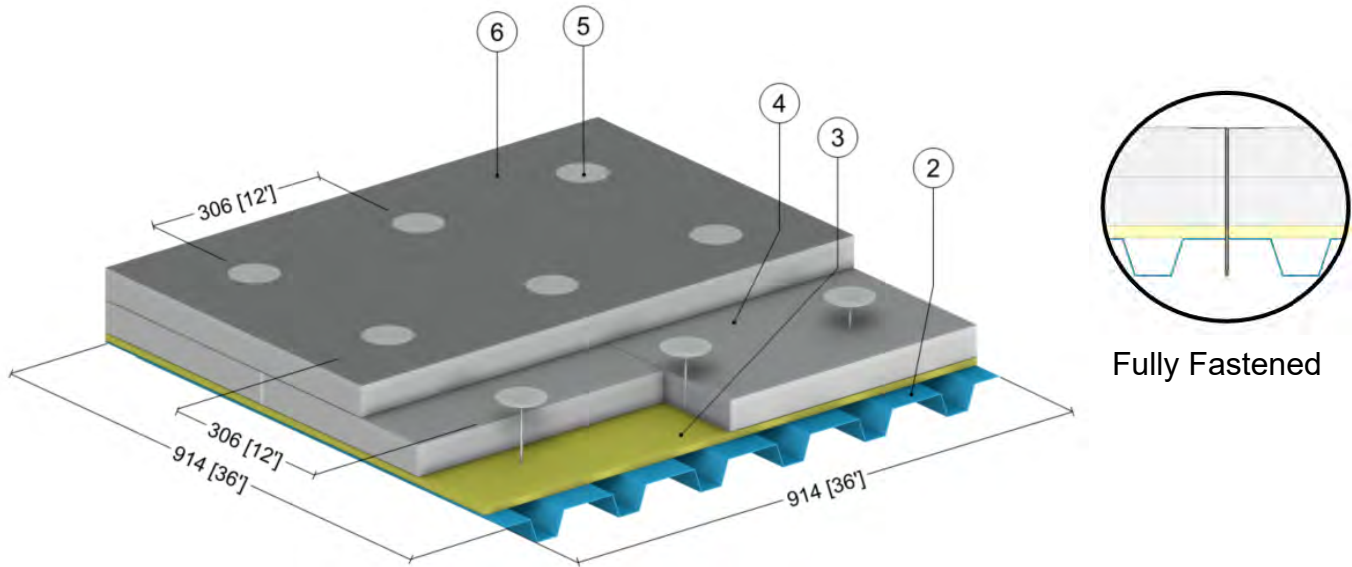

ID	Component	Thickness Inches (mm)	Conductivity Btu-in / ft ² -hr-°F (W/m K)	Nominal Resistance hr-ft ² -°F/Btu (m ² K/W)	Density lb/ft ³ (kg/m ³)	Specific Heat Btu/lb-°F (J/kg K)
1	Interior Films ¹	-	-	R-1.1 (0.19 RSI)	-	-
2	Steel Deck	1/16" (1.6)	430 (62)	-	489 (7830)	0.12 (500)
3	Sheathing	1/2" (13)	1.1 (0.16)	R-0.5 (0.08 RSI)	50 (800)	0.26 (1090)
4	2 Layer Polyisocyanurate Insulation	Varies	-	R-22.8 to R-39.9 (4.02 to 7.03 RSI)	1.8 (28)	0.29 (1220)
5	#14 Steel Fasteners	1/4" (6.1) ∅	430 (62)	-	489 (7830)	0.12 (500)
6	Asphalt Cover Board and Roof Membrane	1/2" (12)	3 (0.43)	R-0.2 (0.03 RSI)	100 (1600)	100 (1500)
7	Exterior Film ¹	-	-	R-0.2 (0.03 RSI)	-	-

¹ Value selected from table 1, p. 26.1 of 2009 ASHRAE Handbook – Fundamentals depending on surface orientation

Detail 10.1.14 | Sloped Wood Framed Roof with Insulation at Ceiling

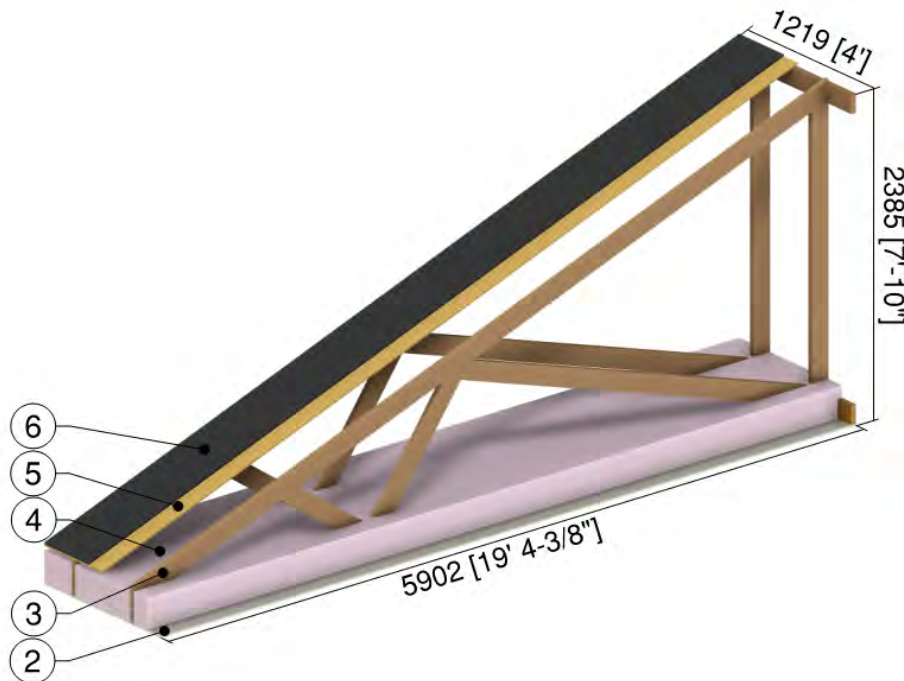

ID	Component	Thickness Inches (mm)	Conductivity Btu-in / ft ² ·hr·°F (W/m K)	Nominal Resistance hr·ft ² ·°F/Btu (m ² K/W)	Density lb/ft ³ (kg/m ³)	Specific Heat Btu/lb·°F (J/kg K)
1	Interior Film ¹	-	-	R-0.6 (0.11 RSI)	-	-
2	Gypsum Board	1/2" (13)	1.1 (0.16)	R-0.5 (0.08 RSI)	50 (800)	0.26 (1090)
3	Roof Truss (24" o.c.)	-	0.69 (0.10)	-	31 (500)	0.45 (1880)
4	Attic Insulation	9" (228)	0.29 (0.042)	R-30 (5.3 RSI)	0.9 (14)	0.17 (710)
5	Roof Sheathing	1/2" (13)	0.69 (0.10)	R-0.7 (0.12 RSI)	31 (500)	0.45 (1880)
6	Asphalt Shingles	-	-	R-0.45 (0.08 RSI)	57 (920)	0.3 (1260)
7	Exterior Film ¹	-	-	R-0.2 (0.03 RSI)	-	-

¹ Value selected from table 1, p. 26.1 of 2009 ASHRAE Handbook – Fundamentals depending on surface orientation

Detail 10.1.15 | Sloped Wood Framed Roof with Insulation at Roof Sheathing



ID	Component	Thickness Inches (mm)	Conductivity Btu-in / ft ² -hr-°F (W/m K)	Nominal Resistance hr-ft ² -°F/Btu (m ² K/W)	Density lb/ft ³ (kg/m ³)	Specific Heat Btu/lb-°F (J/kg K)
1	Interior Film ¹	-	-	R-0.6 (0.11 RSI)	-	-
2	Gypsum Board	1/2" (13)	1.1 (0.16)	R-0.5 (0.08 RSI)	50 (800)	0.26 (1090)
3	Roof Truss (24" o.c.)	-	0.69 (0.10)	-	31 (500)	0.45 (1880)
4	Polyurethane Foam Insulation	5" (127)	0.17 (0.024)	R-30 (5.3 RSI)	1.8 (28)	0.29 (1220)
5	Roof Wood Sheathing	1/2" (13)	0.69 (0.10)	R-0.7 (0.12 RSI)	31 (500)	0.45 (1880)
6	Asphalt Shingles	-	-	R-0.45 (0.08 RSI)	57 (920)	0.3 (1260)
7	Exterior Film ¹	-	-	R-0.2 (0.03 RSI)	-	-

¹ Value selected from table 1, p. 26.1 of 2009 ASHRAE Handbook – Fundamentals depending on surface orientation

Detail 10.1.16

Exterior Insulated Low Sloped Roof with Fully Adhered Roof Membrane and Mineral Wool Insulation – Clear Roof Assembly

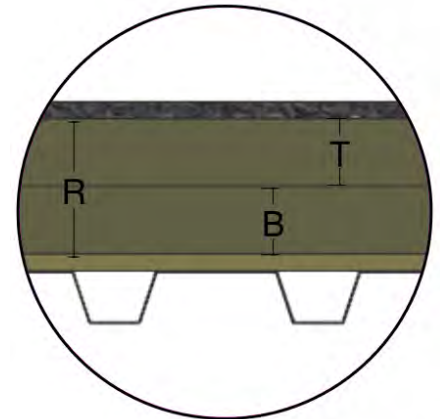
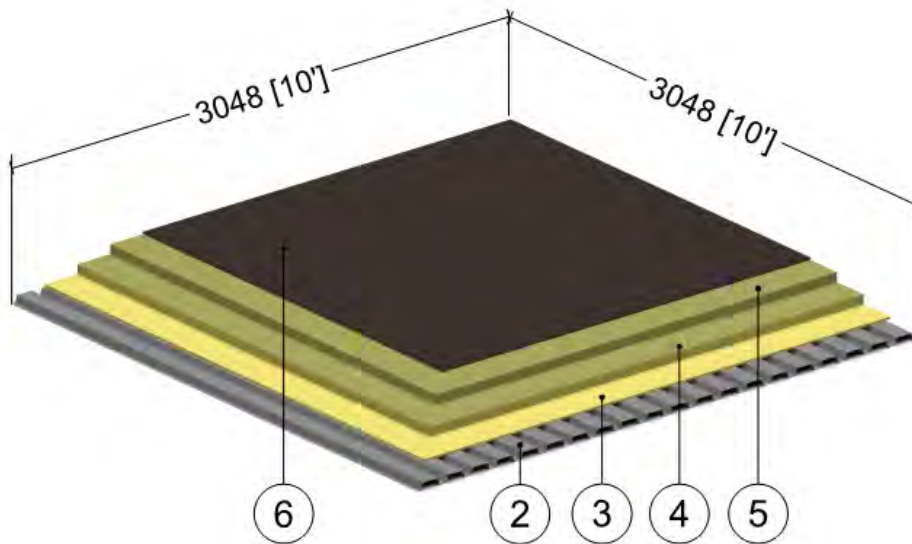

Total Roof Insulation R	Bottom Roof Insulation B	Top Roof Insulation T
R-19.8	R-9.9	R-9.9
R-29.7	R-19.9	R-9.9
R-39.7	R-29.8	R-9.9
R-49.7	R-39.8	R-9.9

ID	Component	Thickness Inches (mm)	Conductivity Btu·in / ft ² ·hr·°F (W/m K)	Nominal Resistance hr·ft ² ·°F/Btu (m ² K/W)	Density lb/ft ³ (kg/m ³)	Specific Heat Btu/lb·°F (J/kg K)
1	Interior Films ¹	-	-	R-1.1 (0.19 RSI)	-	-
2	Steel Deck	1/16" (1.6)	430 (62)	-	489 (7830)	0.12 (500)
3	Gypsum board	1/2" (13)	1.1 (0.16)	R-0.5 (0.08 RSI)	50 (800)	0.26 (1090)
4	Bottom Layer Mineral Wool Insulation	Varies	-	R-9.9 to R-39.8 (1.74 to 7.01 RSI)	1.8 (28)	0.29 (1220)
5	Top Layer Mineral Wool Insulation	2" (51)	-	R-9.9 (1.74 RSI)		
6	Asphalt Cover Board and Roof Membrane	1/2" (12)	3 (0.43)	R-0.2 (0.03 RSI)	100 (1600)	100 (1500)
7	Exterior Film ¹	-	-	R-0.2 (0.03 RSI)	-	-

¹ Value selected from table 1, p. 26.1 of 2009 ASHRAE Handbook – Fundamentals depending on surface orientation

Detail 10.1.17

Exterior Insulated Low Sloped Roof with Fully Adhered Roof Membrane and Mineral Wool and Polyisocyanurate Insulation – Clear Roof Assembly

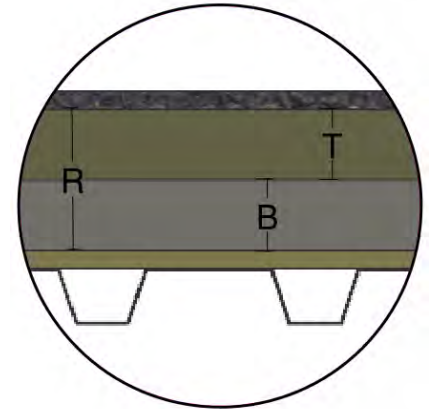
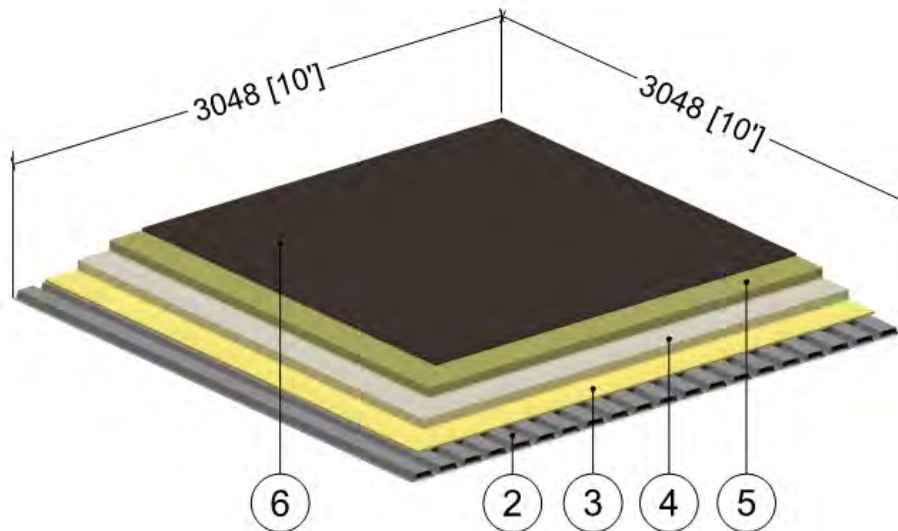

Total Roof Insulation R	Bottom Roof Insulation B	Top Roof Insulation T
R-21.3	R-11.4	R-9.9
R-32.7	R-22.8	R-9.9
R-44.1	R-34.2	R-9.9
R-55.5	R-45.6	R-9.9

ID	Component	Thickness Inches (mm)	Conductivity Btu-in / ft ² ·hr·°F (W/m K)	Nominal Resistance hr·ft ² ·°F/Btu (m ² K/W)	Density lb/ft ³ (kg/m ³)	Specific Heat Btu/lb·°F (J/kg K)
1	Interior Films ¹	-	-	R-1.1 (0.19 RSI)	-	-
2	Steel Deck	1/16" (1.6)	430 (62)	-	489 (7830)	0.12 (500)
3	Gypsum board	1/2" (13)	1.1 (0.16)	R-0.5 (0.08 RSI)	50 (800)	0.26 (1090)
4	Bottom Layer Polyisocyanurate Insulation	Varies	-	R-9.9 to R-39.8 (2.01 to 8.03 RSI)	1.8 (28)	0.29 (1220)
5	Top Layer Mineral Wool Insulation	2" (51)	-	R-9.9 (1.74 RSI)		
6	Asphalt Cover Board and Roof Membrane	1/2" (12)	3 (0.43)	R-0.2 (0.03 RSI)	100 (1600)	100 (1500)
7	Exterior Film ¹	-	-	R-0.2 (0.03 RSI)	-	-

¹ Value selected from table 1, p. 26.1 of 2009 ASHRAE Handbook – Fundamentals depending on surface orientation

Detail 10.2.1

Exterior Insulated Sloped Metal Roof with Metal Sub-Girts (24" o.c.) Supporting Metal Roof – Ridge Intersection

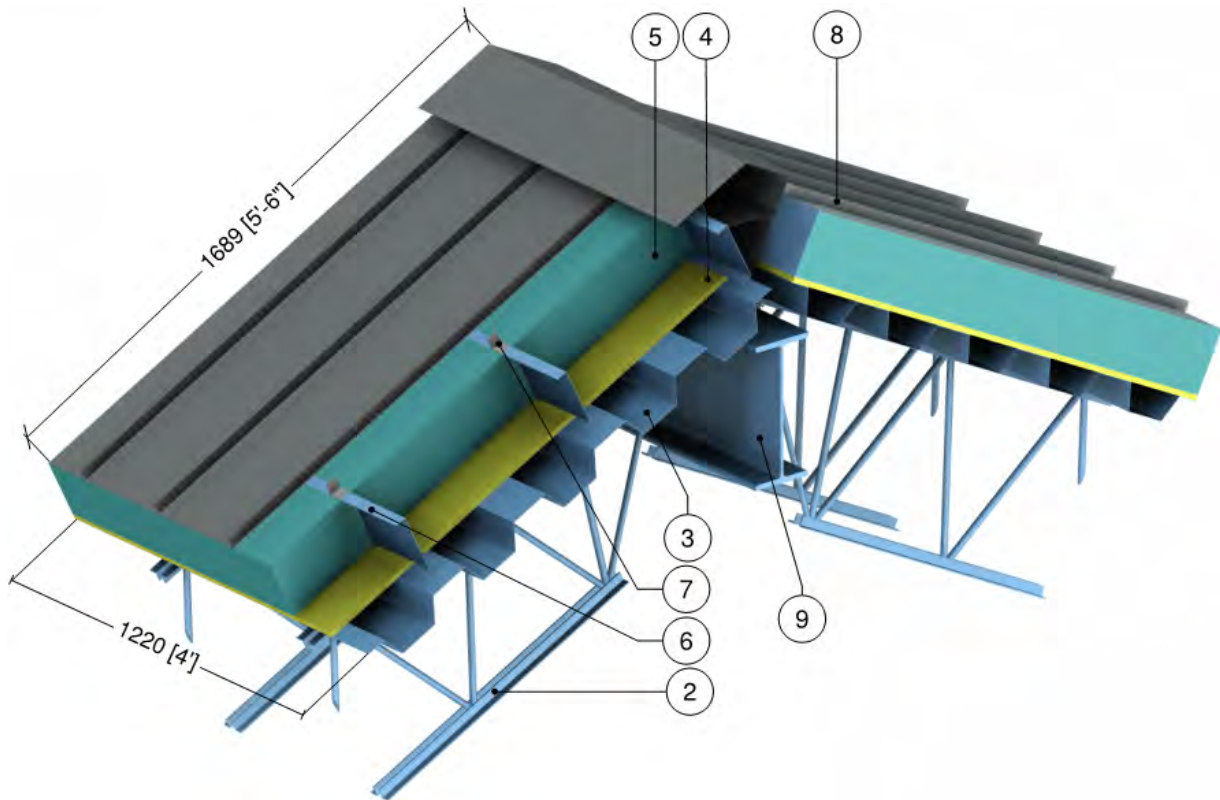

ID	Component	Thickness Inches (mm)	Conductivity Btu·in / ft ² ·hr·°F (W/m K)	Nominal Resistance hr·ft ² ·°F/Btu (m ² K/W)	Density lb/ft ³ (kg/m ³)	Specific Heat Btu/lb·°F (J/kg K)
1	Interior Film ¹	-	-	R-1.1 (0.2 RSI)	-	-
2	Open Web Steel Joist (550C) @ 24" (610) o.c.	-	347 (50)	-	489 (7830)	0.12 (500)
3	Steel Deck	1/16" (1.6)	347 (50)	-	489 (7830)	0.12 (500)
4	Roof Sheathing	1/2" (13)	1.1 (0.16)	R-0.5 (0.08 RSI)	50 (800)	0.26 (1090)
5	Rigid Roof Insulation	Varies	-	R-20 to R-30 (3.52 RSI to 5.28 RSI)	1.8 (28)	0.29 (1220)
6	Sub-Girt with 1 1/2" Flange @ 24" (610) o.c.	16 Gauge	430 (62)	-	489 (7830)	0.12 (500)
7	Roof Clips (1 1/2" x 1 1/2")	16 Gauge	430 (62)	-	489 (7830)	0.12 (500)
8	Metal Roof with Ridge Flashing	24 Gauge	430 (62)	-	489 (7830)	0.12 (500)
9	Steel Beam (W410)	-	347 (50)	-	489 (7830)	0.12 (500)
10	Exterior Film ¹	-	-	R-0.2 (0.03 RSI)	-	-

¹ Value selected from table 1, p. 26.1 of 2009 ASHRAE Handbook – Fundamentals depending on surface orientation

Detail 10.2.2

Insulated Concrete Slab – Concrete Curb or Wall Intersection

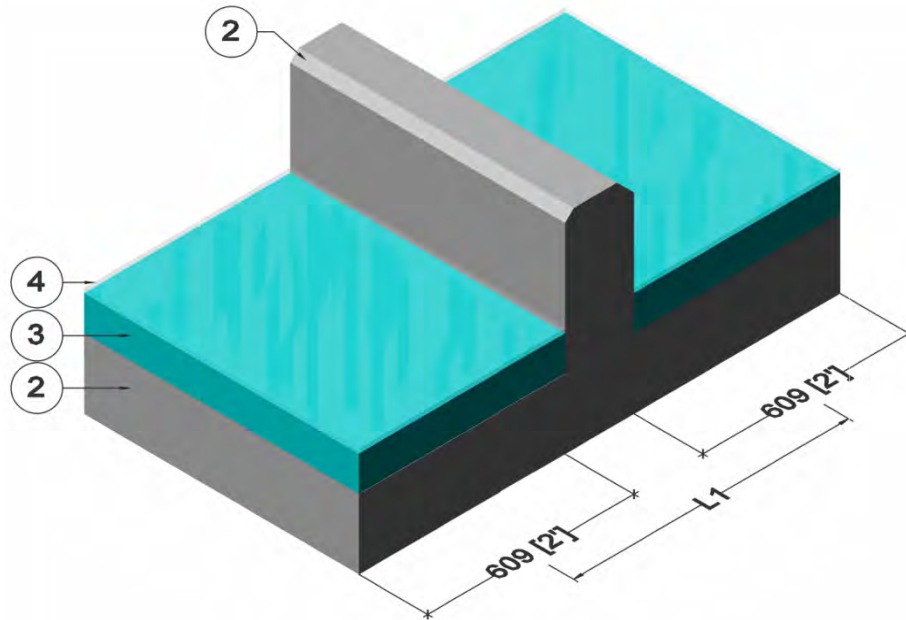

ID	Component	Thickness Inches (mm)	Conductivity Btu·in / ft ² ·hr·°F (W/m K)	Nominal Resistance hr·ft ² ·°F/Btu (m ² K/W)	Density lb/ft ³ (kg/m ³)	Specific Heat Btu/lb·°F (J/kg K)
1	Interior Film ¹	-	-	R-0.6 (0.11 RSI)	-	-
2	Concrete Slab, Curb or Wall	8" (203)	12.5 (1.8)	-	140 (2250)	0.20 (850)
3	Roof Insulation	4" (102)	-	R-20 (3.5 RSI)	1.8 (28)	0.29 (1220)
4	Finish roof material is incorporated into exterior heat transfer coefficient					
5	Exterior Film ¹	-	-	R-0.2 (0.03 RSI)	-	-

¹ Value selected from table 1, p. 26.1 of 2009 ASHRAE Handbook – Fundamentals depending on surface orientation

Detail 10.2.3

Owens Corning Insulated Projected Membrane Roof – Floating Concrete Wall Intersection

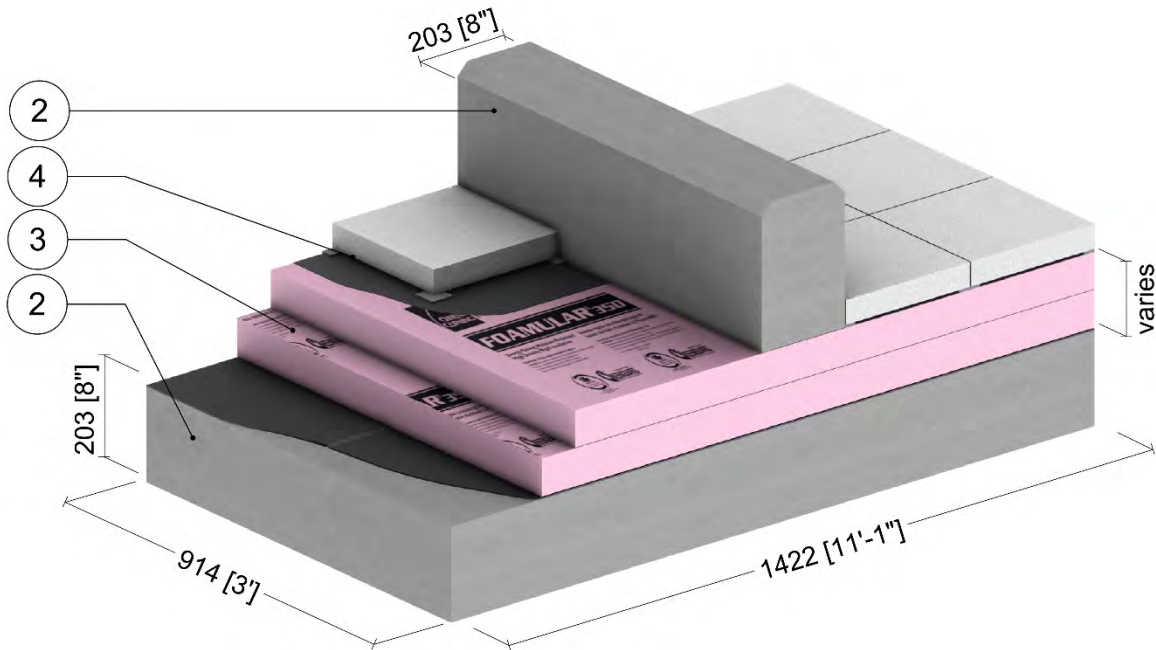

ID	Component	Thickness Inches (mm)	Conductivity Btu-in / ft ² ·hr·°F (W/m K)	Nominal Resistance hr·ft ² ·°F/Btu (m ² K/W)	Density lb/ft ³ (kg/m ³)	Specific Heat Btu/lb·°F (J/kg K)
1	Interior Films ¹	-	-	R-0.6 (0.11 RSI)	-	-
2	Concrete	8" (203)	12.5 (1.8)	-	140 (2250)	0.20 (850)
3	Fomular 350 Extruded Polystyrene Rigid Insulation Type 4	Varies	-	R-20 to R-40 (3.52 RSI to 7.04 RSI)	varies	-
4	Finish roof material is incorporated into exterior heat transfer coefficient					
5	Exterior Film ¹	-	-	R-0.2 (0.03 RSI)	-	-

¹ Value selected from table 1, p. 26.1 of 2009 ASHRAE Handbook – Fundamentals depending on surface orientation

Detail 10.2.4

Exterior Insulated Sloped Metal Roof with Metal Sub-Girts (24" o.c.) Supporting Standing Seam Metal Roof and Curtain Wall – Roof to Wall Intersection with Through Wall Structural Beam and Continuous Through Wall Structural Metal Deck

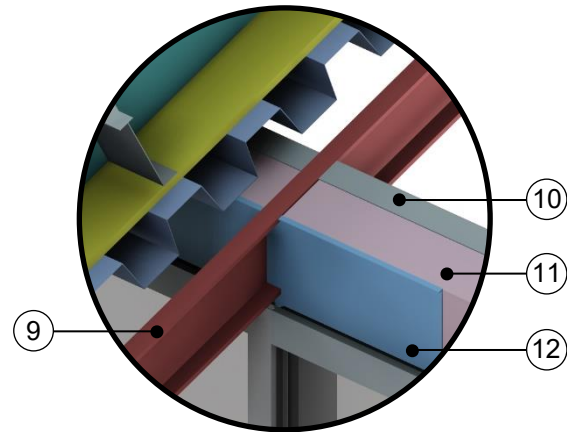
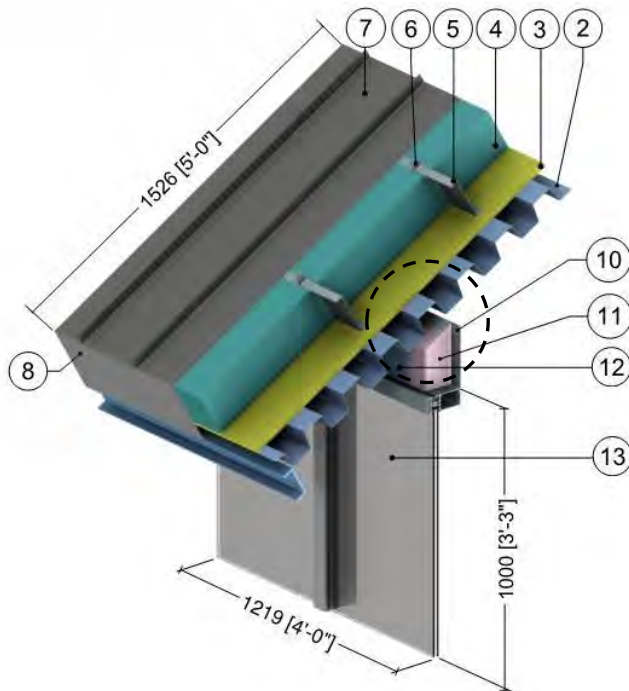

Through Beam and Metal Deck at Curtain Wall

ID	Component	Thickness Inches (mm)	Conductivity Btu-in / ft ² ·hr·°F (W/m K)	Nominal Resistance hr·ft ² ·°F/Btu (m ² K/W)	Density lb/ft ³ (kg/m ³)	Specific Heat Btu/lb·°F (J/kg K)
1	Interior Films ¹	-	-	R-0.6 to R-1.1 (0.12 RSI to 0.20 RSI)	-	-
2	Steel Deck	1/16" (1.6)	347 (50)	-	489 (7830)	0.12 (500)
3	Roof Sheathing	1/2" (13)	1.1 (0.16)	R-0.5 (0.08 RSI)	50 (800)	0.26 (1090)
4	Rigid Roof Insulation	7" (183)	0.2 (0.03)	R-35 (6.16 RSI)	1.8 (28)	0.29 (1220)
5	Sub-Girt with 1 1/2" Flange @ 24" (610) o.c.	16 gauge	430 (62)	-	489 (7830)	0.12 (500)
6	Roof Clips (1 1/2" x 1 1/2")	16 gauge	430 (62)	-	489 (7830)	0.12 (500)
7	Metal Roof	24 gauge	430 (62)	-	489 (7830)	0.12 (500)
8	Roof Closure Panel	16 gauge	430 (62)	-	489 (7830)	0.12 (500)
9	Steel Beam (W410)	-	347 (50)	-	489 (7830)	0.12 (500)
10	Interior Closure Panel	12 gauge	430 (62)	-	489 (7830)	0.12 (500)
11	Fiberglass Insulation	4 1/2" (118)	0.24 (0.034)	R-19 (3.35 RSI)	4 (64)	0.20 (850)
12	Exterior Closure Panel	12 gauge	430 (62)	-	489 (7830)	0.12 (500)
13	Aluminum Curtain Wall Vision System: thermally broken frame, double glazed IGU U _{COG} = 0.32 BTU/hr·ft ² ·°F (1.82 W/m ² K) ²					
14	Exterior Film ¹	-	-	R-0.2 (0.03 RSI)	-	-

¹ Value selected from table 1, p. 26.1 of 2009 ASHRAE Handbook – Fundamentals depending on surface orientation

² The thermal conductivity of air spaces within framing was found using ISO 100077-2

Detail 10.2.5

Exterior Insulated Sloped Metal Roof with Metal Sub-Girts (24" o.c.) Supporting Standing Seam Metal Roof and Curtain Wall – Roof to Wall Intersection with Through Wall Structural Beam and Thermally Broken Structural Metal Deck

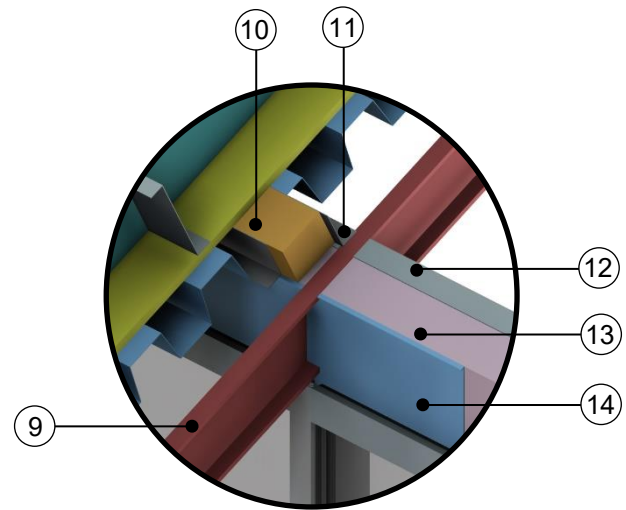
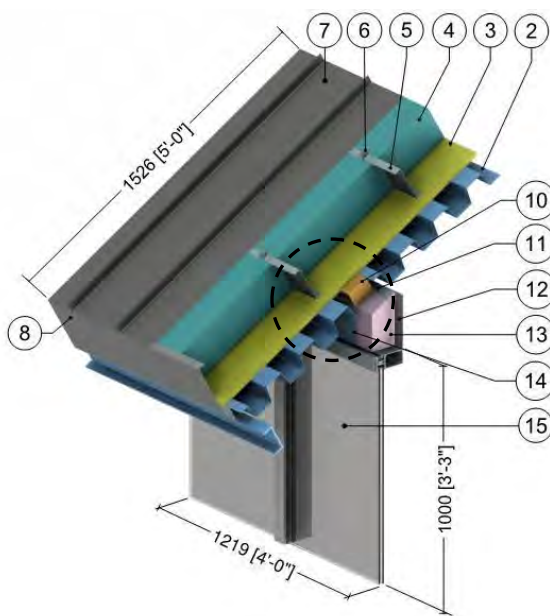

Through Beam and Thermally Broken Metal Deck

ID	Component	Thickness Inches (mm)	Conductivity Btu-in / ft ² -hr-°F (W/m K)	Nominal Resistance hr-ft ² -°F/Btu (m ² K/W)	Density lb/ft ³ (kg/m ³)	Specific Heat Btu/lb-°F (J/kg K)
1	Interior Films ¹	-	-	R-0.6 to R-1.1 (0.12 RSI to 0.20 RSI)	-	-
2	Steel Deck	1/16" (1.6)	347 (50)	-	489 (7830)	0.12 (500)
3	Roof Sheathing	1/2" (13)	1.1 (0.16)	R-0.5 (0.08 RSI)	50 (800)	0.26 (1090)
4	Rigid Roof Insulation	7" (183)	0.2 (0.03)	R-35 (6.16 RSI)	1.8 (28)	0.29 (1220)
5	Sub-Girt with 1 1/2" Flange @ 24" (610) o.c.	16 gauge	430 (62)	-	489 (7830)	0.12 (500)
6	Roof Clips (1 1/2" x 1 1/2")	16 gauge	430 (62)	-	489 (7830)	0.12 (500)
7	Metal Roof	24 gauge	430 (62)	-	489 (7830)	0.12 (500)
8	Roof Closure Panel	16 gauge	430 (62)	-	489 (7830)	0.12 (500)
9	Steel Beam (W410)	-	347 (50)	-	489 (7830)	0.12 (500)
10	Continuous Spray Foam Insulation	4" (100)	0.17 (0.024)	R-24 (4.23 RSI)	2.8 (39)	0.35 (1470)
11	Stiffening Brackets	16 gauge	430 (62)	-	489 (7830)	0.12 (500)
12	Interior Closure Panel	12 gauge	430 (62)	-	489 (7830)	0.12 (500)
13	Fiberglass Insulation	4 1/2" (118)	0.24 (0.034)	R-19 (3.35 RSI)	4 (64)	0.20 (850)
14	Exterior Closure Panel	12 gauge	430 (62)	-	489 (7830)	0.12 (500)
15	Aluminum Curtain Wall Vision System: thermally broken frame, double glazed IGU U _{COG} = 0.32 BTU/hr-ft ² -°F (1.82 W/m ² K) ²					
16	Exterior Film ¹	-	-	R-0.2 (0.03 RSI)	-	-

¹ Value selected from table 1, p. 26.1 of 2009 ASHRAE Handbook – Fundamentals depending on surface orientation

² The thermal conductivity of air spaces within framing was found using ISO 100077-2

Detail 10.2.6

Exterior Insulated Sloped Metal Roof with Metal Sub-Girts (24" o.c.) Supporting Standing Seam Metal Roof and Curtain Wall – Roof to Wall Intersection with Through Wall Structural Beam and Fully Insulated Soffit

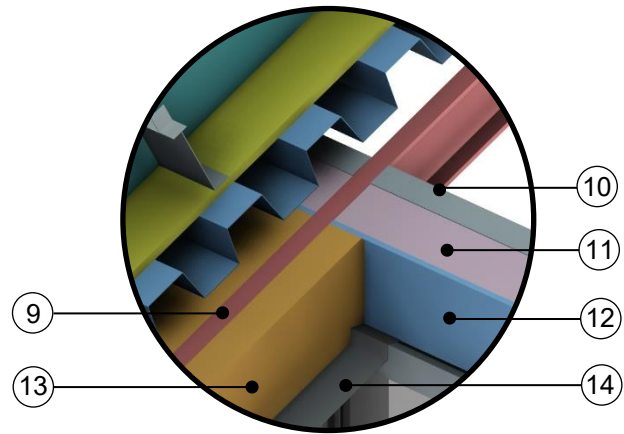
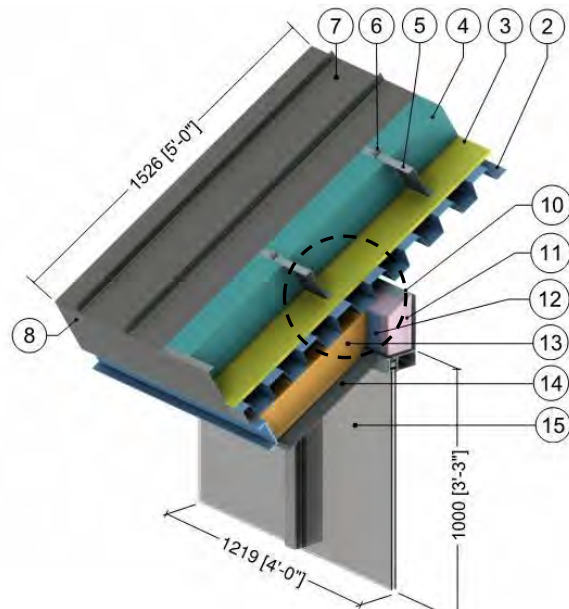

Through Beam and Metal Deck at Soffit

ID	Component	Thickness Inches (mm)	Conductivity Btu-in / ft ² -hr-°F (W/m K)	Nominal Resistance hr-ft ² -°F/Btu (m ² K/W)	Density lb/ft ³ (kg/m ³)	Specific Heat Btu/lb-°F (J/kg K)
1	Interior Films ¹	-	-	R-0.6 to R-1.1 (0.12 RSI to 0.20 RSI)	-	-
2	Steel Deck	1/16" (1.6)	347 (50)	-	489 (7830)	0.12 (500)
3	Roof Sheathing	1/2" (13)	1.1 (0.16)	R-0.5 (0.08 RSI)	50 (800)	0.26 (1090)
4	Rigid Roof Insulation	7" (183)	0.2 (0.03)	R-35 (6.16 RSI)	1.8 (28)	0.29 (1220)
5	Sub-Girt with 1 1/2" Flange @ 24" (610) o.c.	16 gauge	430 (62)	-	489 (7830)	0.12 (500)
6	Roof Clips (1 1/2" x 1 1/2")	16 gauge	430 (62)	-	489 (7830)	0.12 (500)
7	Metal Roof	24 gauge	430 (62)	-	489 (7830)	0.12 (500)
8	Roof Closure Panel	16 gauge	430 (62)	-	489 (7830)	0.12 (500)
9	Steel Beam	-	347 (50)	-	489 (7830)	0.12 (500)
10	Curtain Wall Bracket and Closure Panel	12 gauge	430 (62)	-	489 (7830)	0.12 (500)
11	Curtain Wall Fill Insulation	4 1/2" (118)	0.24 (0.034)	R-19 (3.35 RSI)	4 (64)	0.20 (850)
12	Curtain Wall Closure Panel	12 gauge	430 (62)	-	489 (7830)	0.12 (500)
13	Rigid Soffit Insulation	6" (150)	0.17 (0.024)	R-36 (6.34 RSI)	2.8 (39)	0.35 (1470)
14	Metal Soffit Panel	24 gauge	430 (62)	-	489 (7830)	0.12 (500)
15	Aluminum Curtain Wall Vision System: thermally broken frame, double glazed IGU U _{COG} = 0.32 BTU/hr-ft ² -°F (1.82 W/m ² K) ²					
16	Exterior Film ¹	-	-	R-0.2 (0.03 RSI)	-	-

¹ Value selected from table 1, p. 26.1 of 2009 ASHRAE Handbook – Fundamentals depending on surface orientation

² The thermal conductivity of air spaces within framing was found using ISO 100077-2

Detail 10.2.7

Aluminum Framed Double Glazed Skylight – Exterior Insulated Concrete Curb Intersection

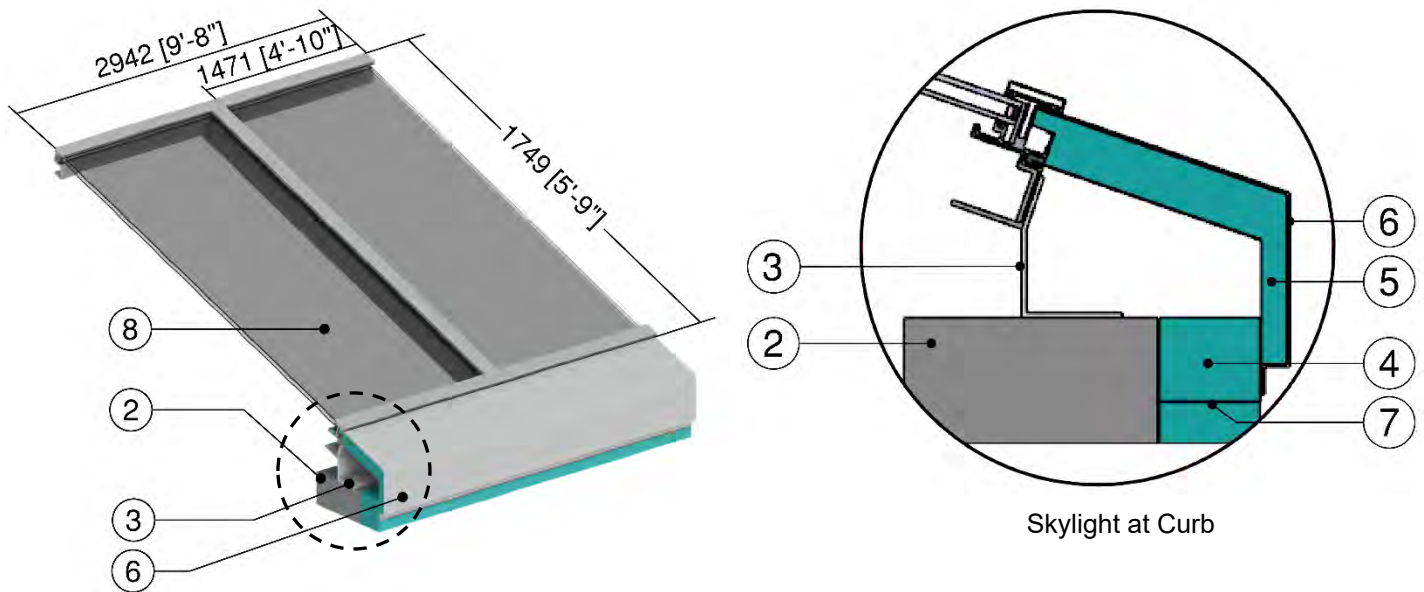

ID	Component	Thickness Inches (mm)	Conductivity Btu-in / ft ² ·hr·°F (W/m K)	Nominal Resistance hr·ft ² ·°F/Btu (m ² K/W)	Density lb/ft ³ (kg/m ³)	Specific Heat Btu/lb·°F (J/kg K)
1	Interior Films ¹	-	-	R-0.6 to R-1.2 (0.11 RSI to 0.22 RSI)	-	-
2	Curb	5" (127)	12.5 (1.8)	-	140 (2250)	0.20 (850)
3	Frame Angle	0.19" (5)	347 (50)	-	489 (7830)	0.12 (500)
4	Curb Insulation	4" (102)	0.20 (0.029)	-	1.8 (28)	0.29 (1220)
5	Flashing Insulation	Varies	0.20 (0.029)	-	1.8 (28)	0.29 (1220)
6	Flashing	20 gauge	1109 (160)	-	171 (2739)	0.21 (900)
7	Horizontal Z-Girt	18 gauge	430 (62)	-	489 (7830)	0.12 (500)
8	Aluminum Curtain Wall Vision System: thermally broken frame, double glazed IGU $U_{COG} = 0.45 \text{ BTU/hr}\cdot\text{ft}^2\cdot\text{°F}$ (1.33 W/m ² K) ²					
9	Exterior Film ¹	-	-	R-0.2 to R-0.7 (0.03 RSI to 0.12 RSI)	-	-

¹ Value selected from table 1, p. 26.1 of 2009 ASHRAE Handbook – Fundamentals depending on surface orientation

² The thermal conductivity of air spaces within framing was found using ISO 100077-2

Detail 10.3.1

Exterior Insulated Conventional Flat Roof – Roof Anchor

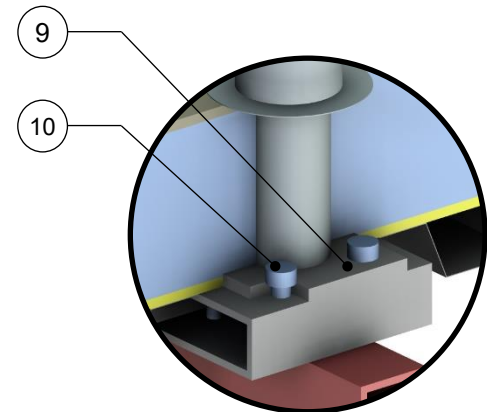
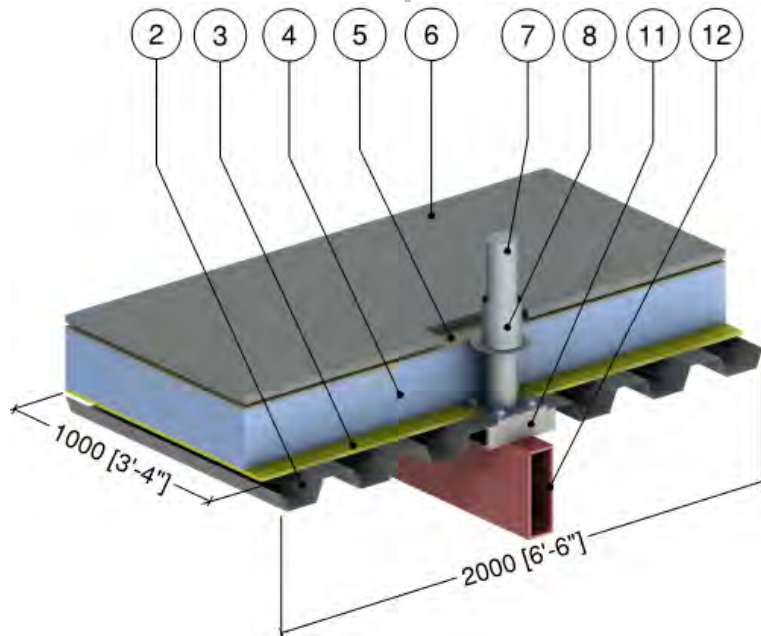

Roof Anchor

ID	Component	Thickness Inches (mm)	Conductivity Btu-in / ft ² ·hr·°F (W/m K)	Nominal Resistance hr·ft ² ·°F/Btu (m ² K/W)	Density lb/ft ³ (kg/m ³)	Specific Heat Btu/lb·°F (J/kg K)
1	Interior Film ¹	-	-	R-1.1 (0.19 RSI)	-	-
2	Steel Deck	1/16" (1.6)	347 (50)	-	489 (7830)	0.12 (500)
3	Gypsum Board	1/2" (13)	1.1 (0.16)	R-0.5 (0.08 RSI)	50 (800)	0.26 (1090)
4	Extruded Polystyrene Insulation (XPS)	8" (203)	0.20 (0.029)	R-40 (7.04 RSI)	1.8 (28)	0.29 (1220)
5	Asphalt Cover Board and Roof Membrane	1/2" (13)	3 (0.43)	R-0.2 (0.03 RSI)	100 (1600)	100 (1500)
6	Concrete Pavers	1" (25)	12.5 (1.8)	-	140 (2250)	0.20 (850)
7	Roof Anchor	1/4" (6)	430 (62)	-	489 (7830)	0.12 (500)
8	Roof Anchor Flashing	18 Gauge	1100 (160)	-	171 (2739)	0.21 (900)
9	8" x 8" x 5/8" Base Plate	5/8" (16)	430 (62)	-	489 (7830)	0.12 (500)
10	Stainless Steel Bolts	3/4" (6) ∅	117 (17)	-	489 (7830)	0.12 (500)
11	3" x 8" x 11" HSS	3/8" (10)	347 (50)	-	489 (7830)	0.12 (500)
12	Structural Steel	3/8" (10)	347 (50)	-	489 (7830)	0.12 (500)
13	Exterior Film ¹	-	-	R-0.2 (0.03 RSI)	-	-

¹ Value selected from table 1, p. 26.1 of 2009 ASHRAE Handbook – Fundamentals depending on surface orientation

Detail 10.3.2

Exterior Insulated Conventional Flat Roof – Armatherm Thermal Break under Roof Anchor

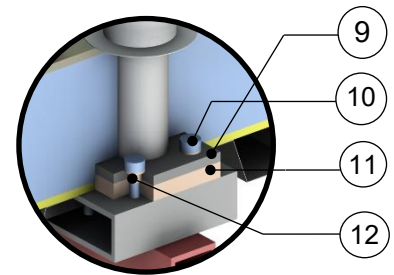
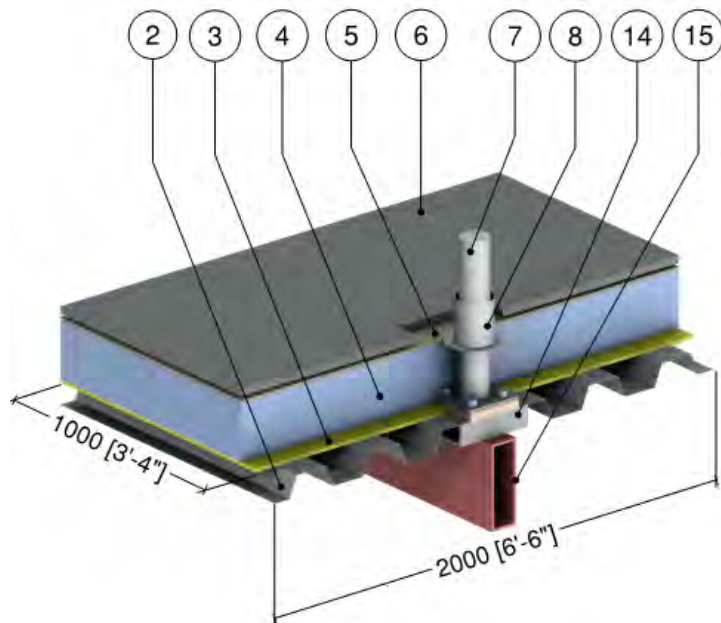

Armatherm FRR Roof Anchor Thermal Break

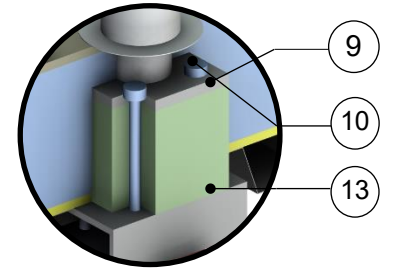

Armatherm 500 Roof Anchor Thermal Break

ID	Component	Thickness Inches (mm)	Conductivity Btu-in / ft ² ·hr·°F (W/m K)	Nominal Resistance hr·ft ² ·°F/Btu (m ² K/W)	Density lb/ft ³ (kg/m ³)	Specific Heat Btu/lb·°F (J/kg K)
1	Interior Film ¹	-	-	R-1.1 (0.19 RSI)	-	-
2	Steel Deck	1/16" (1.6)	347 (50)	-	489 (7830)	0.12 (500)
3	Gypsum Board	1/2" (13)	1.1 (0.16)	R-0.5 (0.08 RSI)	50 (800)	0.26 (1090)
4	Extruded Polystyrene Insulation (XPS)	8" (203)	0.20 (0.029)	R-40 (7.04 RSI)	1.8 (28)	0.29 (1220)
5	Asphalt Cover Board and Roof Membrane	1/2" (13)	3 (0.43)	R-0.2 (0.03 RSI)	100 (1600)	100 (1500)
6	Concrete Pavers	1" (25)	12.5 (1.8)	-	140 (2250)	0.20 (850)
7	Roof Anchor	1/4" (6)	430 (62)	-	489 (7830)	0.12 (500)
8	Roof Anchor Flashing	18 Gauge	1100 (160)	-	171 (2739)	0.21 (900)
9	8" x 8" x 5/8" Base Plate	5/8" (16)	430 (62)	-	489 (7830)	0.12 (500)
10	Stainless Steel Bolts	3/4" (6) ϕ	117 (17)	-	489 (7830)	0.12 (500)
11	Armatherm FRR Thermal Break	1/2" (13)	1.4 (0.2)	-	85 (1362)	-
12	Armatherm FRR Washers and Bushing	-	1.4 (0.2)	-	85 (1362)	-
13	Armatherm 500 Thermal Break	6" (152)	0.32 (0.05)	-	-	-
14	3" x 8" x 11" HSS	3/8" (10)	347 (50)	-	489 (7830)	0.12 (500)
15	Structural Steel	3/8" (10)	347 (50)	-	489 (7830)	0.12 (500)
16	Exterior Film ¹	-	-	R-0.2 (0.03 RSI)	-	-

¹ Value selected from table 1, p. 26.1 of 2009 ASHRAE Handbook – Fundamentals depending on surface orientation

Detail 10.3.3

Exterior Insulated Conventional Low-Sloped Roof – Roof Anchor

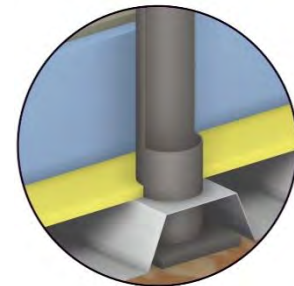
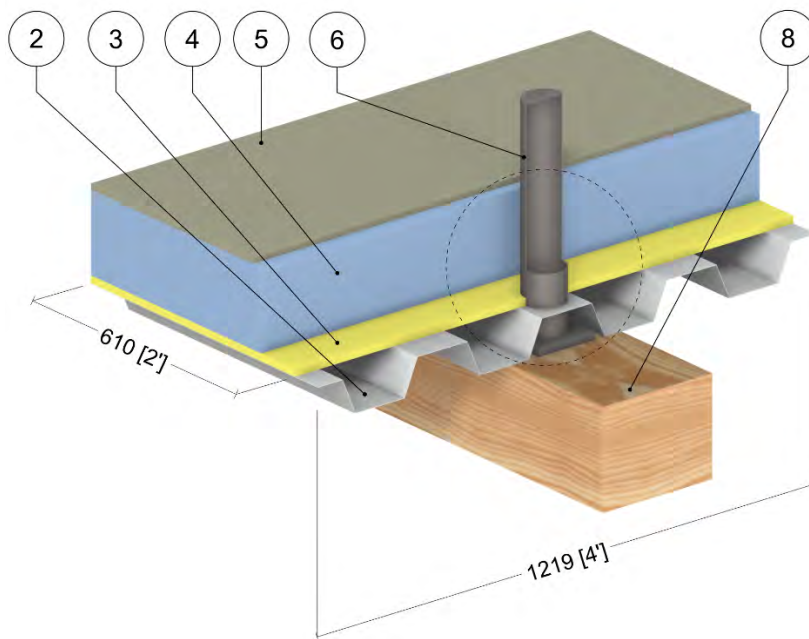

Without Fill Insulation

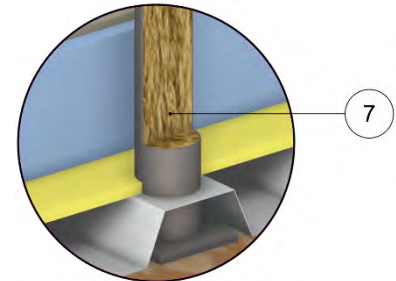

With Fill Insulation

ID	Component	Thickness Inches (mm)	Conductivity Btu-in / ft ² ·hr·°F (W/m K)	Nominal Resistance hr·ft ² ·°F/Btu (m ² K/W)	Density lb/ft ³ (kg/m ³)	Specific Heat Btu/lb·°F (J/kg K)
1	Interior Film ¹	-	-	R-1.1 (0.19 RSI)	-	-
2	Steel Deck	1/32" (1.1)	430 (62)	-	489 (7830)	0.12 (500)
3	Gypsum Board	5/8" (16)	1.1 (0.16)	R-0.6 (0.10 RSI)	50 (800)	0.26 (1090)
4	Extruded Polystyrene Insulation (XPS)	6-7/8" (175)	0.20 (0.029)	R-34.3 (6.03 RSI)	1.8 (28)	0.29 (1220)
5	Sheathing Board	1/2" (13)	1.1 (0.16)	R-0.5 (0.08 RSI)	50 (800)	0.26 (1090)
6	Roof Anchor	3/16" (4.8)	347 (50)	-	489 (7830)	0.12 (500)
7	Mineral Wool Insulation	-	0.24 (0.034)	-	4 (64)	0.20 (850)
8	Glulam Beam	8-1/2" (216)	0.97 (0.14)	-	31 (500)	0.45 (1880)
12	Exterior Film ¹	-	-	R-0.2 (0.03 RSI)	-	-

¹ Value selected from table 1, p. 26.1 of 2009 ASHRAE Handbook – Fundamentals depending on surface orientation

Detail 10.3.4

Exterior Insulated Conventional Low-Sloped Roof – Thermal Break in Roof Anchor

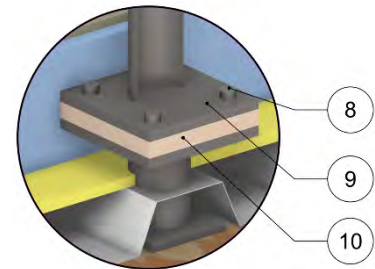
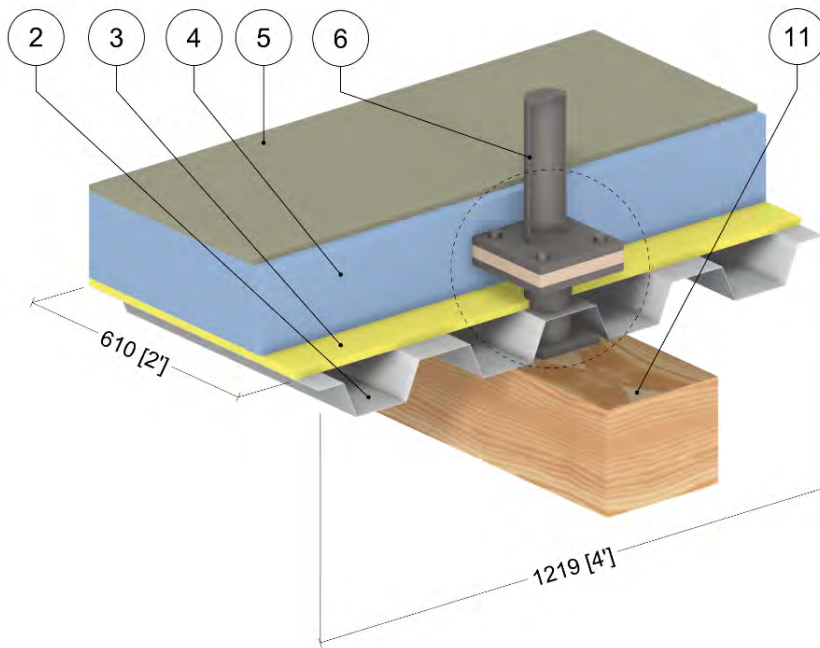

Without Fill Insulation

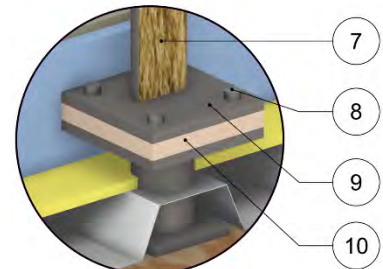

With Fill Insulation

ID	Component	Thickness Inches (mm)	Conductivity Btu-in / ft ² -hr-°F (W/m K)	Nominal Resistance hr-ft ² -°F/Btu (m ² K/W)	Density lb/ft ³ (kg/m ³)	Specific Heat Btu/lb-°F (J/kg K)
1	Interior Film ¹	-	-	R-1.1 (0.19 RSI)	-	-
2	Steel Deck	1/32" (1.1)	430 (62)	-	489 (7830)	0.12 (500)
3	Gypsum Board	5/8" (16)	1.1 (0.16)	R-0.6 (0.10 RSI)	50 (800)	0.26 (1090)
4	Extruded Polystyrene Insulation (XPS)	6-7/8" (175)	0.20 (0.029)	R-34.3 (6.03 RSI)	1.8 (28)	0.29 (1220)
5	Sheathing Board	1/2" (13)	1.1 (0.16)	R-0.5 (0.08 RSI)	50 (800)	0.26 (1090)
6	Roof Anchor	3/16" (4.8)	347 (50)	-	489 (7830)	0.12 (500)
7	Mineral Wool Insulation	-	0.24 (0.034)	-	4 (64)	0.20 (850)
8	Fasteners	1/2" (13) ∅	430 (62)	-	489 (7830)	0.12 (500)
9	8" x 8" x 5/8" Base Plate	5/8" (16)	347 (50)	-	489 (7830)	0.12 (500)
10	Thermal Break	1" (25)	1.8 (0.26)	-	108 (1730)	-
11	Glulam Beam	8-1/2" (216)	0.97 (0.14)	-	31 (500)	0.45 (1880)
12	Exterior Film ¹	-	-	R-0.2 (0.03 RSI)	-	-

¹ Value selected from table 1, p. 26.1 of 2009 ASHRAE Handbook – Fundamentals depending on surface orientation

Detail 10.4.1

Exterior Insulated Low Sloped Roof with Fully Adhered Roof Membrane and Mineral Wool Insulation - Flange-Style Drain Penetration

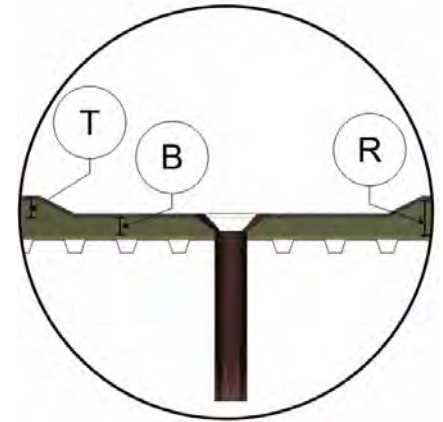
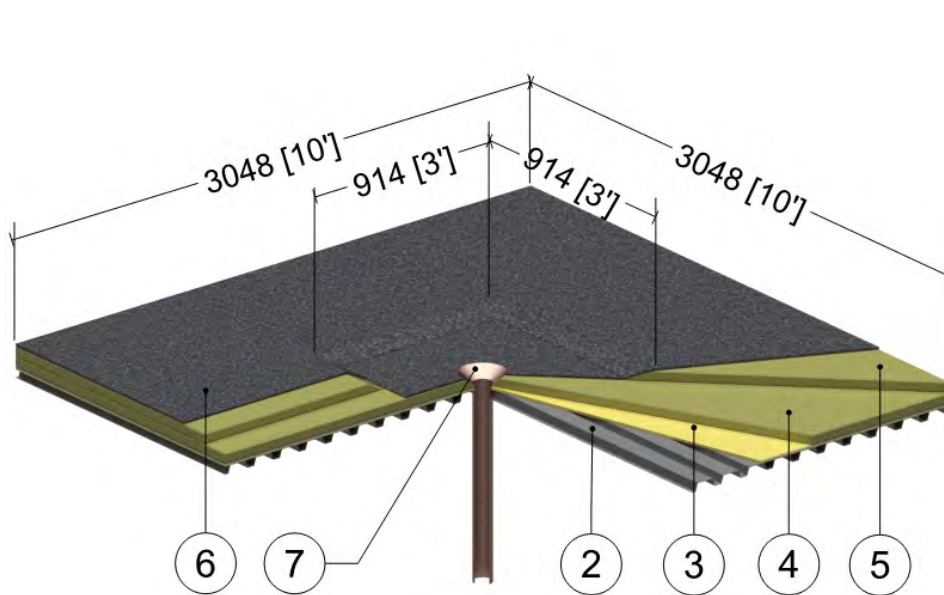

Total Roof Insulation R	Bottom Roof Insulation B	Top Roof Insulation T
R-19.8	R-9.9	R-9.9
R-29.7	R-19.9	R-9.9
R-39.7	R-29.8	R-9.9
R-49.7	R-39.8	R-9.9

ID	Component	Thickness Inches (mm)	Conductivity Btu-in / ft ² ·hr·°F (W/m K)	Nominal Resistance hr·ft ² ·°F/Btu (m ² K/W)	Density lb/ft ³ (kg/m ³)	Specific Heat Btu/lb·°F (J/kg K)
1	Interior Films ¹	-	-	R-1.1 (0.19 RSI)	-	-
2	Steel Deck	1/16" (1.6)	430 (62)	-	489 (7830)	0.12 (500)
3	Gypsum board	1/2" (13)	1.1 (0.16)	R-0.5 (0.08 RSI)	50 (800)	0.26 (1090)
4	Bottom Layer Mineral Wool Insulation	Varies	-	R-9.9 to R-39.8 (1.74 to 7.01 RSI)	1.8 (28)	0.29 (1220)
5	Top Layer Mineral Wool Insulation	2" (51)	-	R-9.9 (1.74 RSI)		
6	Asphalt Cover Board and Roof Membrane	1/2" (12)	3 (0.43)	R-0.2 (0.03 RSI)	100 (1600)	100 (1500)
7	Flanged Copper Drain	16 ga.	2672 (385)	-	559 (8940)	0.092 (385)
8	Exterior Film ¹	-	-	R-0.2 (0.03 RSI)	-	-

¹ Value selected from table 1, p. 26.1 of 2009 ASHRAE Handbook – Fundamentals depending on surface orientation

Detail 10.4.2

Exterior Insulated Low Sloped Roof with Fully Adhered Roof Membrane and Mineral Wool and Polyisocyanurate Insulation - Flange-Style Drain Penetration

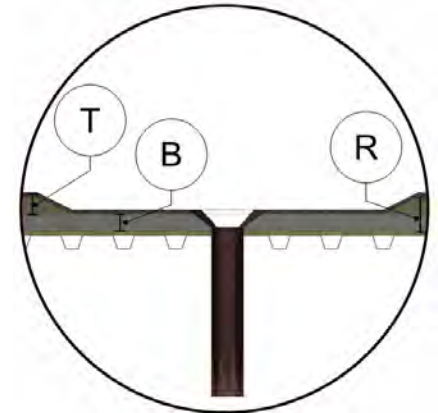
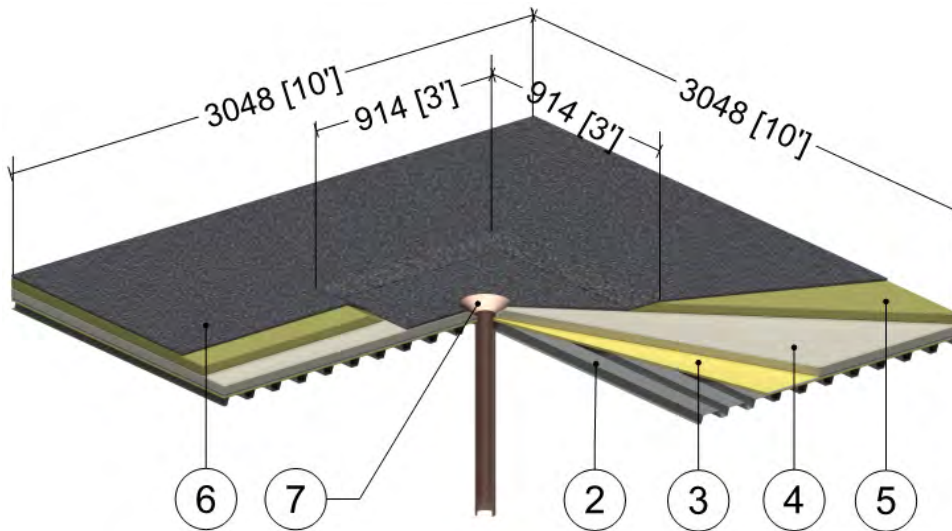

Total Roof Insulation R	Bottom Roof Insulation B	Top Roof Insulation T
R-21.3	R-11.4	R-9.9
R-32.7	R-22.8	R-9.9
R-44.1	R-34.2	R-9.9
R-55.5	R-45.6	R-9.9

ID	Component	Thickness Inches (mm)	Conductivity Btu-in / ft ² ·hr·°F (W/m K)	Nominal Resistance hr·ft ² ·°F/Btu (m ² K/W)	Density lb/ft ³ (kg/m ³)	Specific Heat Btu/lb·°F (J/kg K)
1	Interior Films ¹	-	-	R-1.1 (0.19 RSI)	-	-
2	Steel Deck	1/16" (1.6)	430 (62)	-	489 (7830)	0.12 (500)
3	Gypsum board	1/2" (13)	1.1 (0.16)	R-0.5 (0.08 RSI)	50 (800)	0.26 (1090)
4	Bottom Layer Polyisocyanurate Insulation	Varies	-	R-9.9 to R-39.8 (2.01 to 8.03 RSI)	1.8 (28)	0.29 (1220)
5	Top Layer Mineral Wool Insulation	2" (51)	-	R-9.9 (1.74 RSI)	-	-
6	Asphalt Cover Board and Roof Membrane	1/2" (12)	3 (0.43)	R-0.2 (0.03 RSI)	100 (1600)	100 (1500)
7	Flanged Copper Drain	16 ga.	2672 (385)	-	559 (8940)	0.092 (385)
8	Exterior Film ¹	-	-	R-0.2 (0.03 RSI)	-	-

¹ Value selected from table 1, p. 26.1 of 2009 ASHRAE Handbook – Fundamentals depending on surface orientation

APPENDIX B – CATALOGUE THERMAL DATA SHEETS



CATALOGUE INDEX

Introduction	B.0.i
1.0 Window Wall	B.1.i
2.0 Conventional Curtain Wall	B.2.i
3.0 Unitized Curtain Wall	B.3.i
4.0 High Performance Curtain Wall	B.4.i
5.0 Steel-Frame Construction	B.5.i
6.0 Metal Buildings	B.6.i
7.0 Concrete and Mass Masonry Construction	B.7.i
8.0 Wood-Frame and Timber Construction	B.8.i
9.0 Doors and Balconies	B.9.i
10.0 Roofs	B.10.i

Introduction

Introduction

Appendix B contains the catalogue of thermal performance data sheets for all the details available for this guide. The thermal performance information includes U-values, transmittance values and condensation indices. Appendix B consists of a catalogue with full thermal information for each detail.

Catalogue Index	
1.	Window Wall
2.	Conventional Curtain Wall
3.	Unitized Curtain Wall
4.	High Performance Curtain Wall
5.	Steel-Framed Construction
6.	Metal Buildings
7.	Concrete and Mass Masonry Construction
8.	Wood-Frame and Timber Construction
9.	Balconies and Doors
10.	Roofs

Each thermal data sheet, along with its matching material data sheet, is meant to be standalone. For instance, Detail 5.2.5 is a balcony slab detail for a steel stud assembly. That data sheet contains the material information for both the slab detail, and the clear field steel stud assembly above and below it. The clear field steel stud assembly material data sheet 5.1.14 is not additionally required to analyze the slab detail. Additionally, some assemblies contain more than one interface detail, so while they are arranged by major detail type (slab, then parapet etc.), there may be other interface details contained within it. Each thermal data sheet contains the thermal performance values for all interface details contained within that assembly detail. Note that some clear field assemblies do not have their own individual thermal data sheet and may be included within other thermal data sheets. For instance, there is no separate clear field data sheet for an interior insulated concrete wall, however there is clear field data available for that wall within the slab interface detail 7.2.2.

Modelling Assumptions

- Exterior surfaces and air spaces include convection, conduction and radiation heat exchange.
- The models were evaluated at non-dimensionalized temperatures, where 0 is the exterior temperature and 1 is the interior. This was done to allow the results to be applicable to any temperature difference. See condensation indices below for more information.
- The model was analyzed at steady state, so thermal mass is not taken into account within assembly U-values.
- Air leakage was not taken into account. It was assumed materials were well fit together
- Contact resistances between materials were used

Additional modeling parameters and assumptions can be found in Section 5 of ASHRAE 1365-RP.

Thermal Data Sheets

Each thermal data sheet contains several pieces of information. An example thermal data sheet is shown below with a description for each section following.

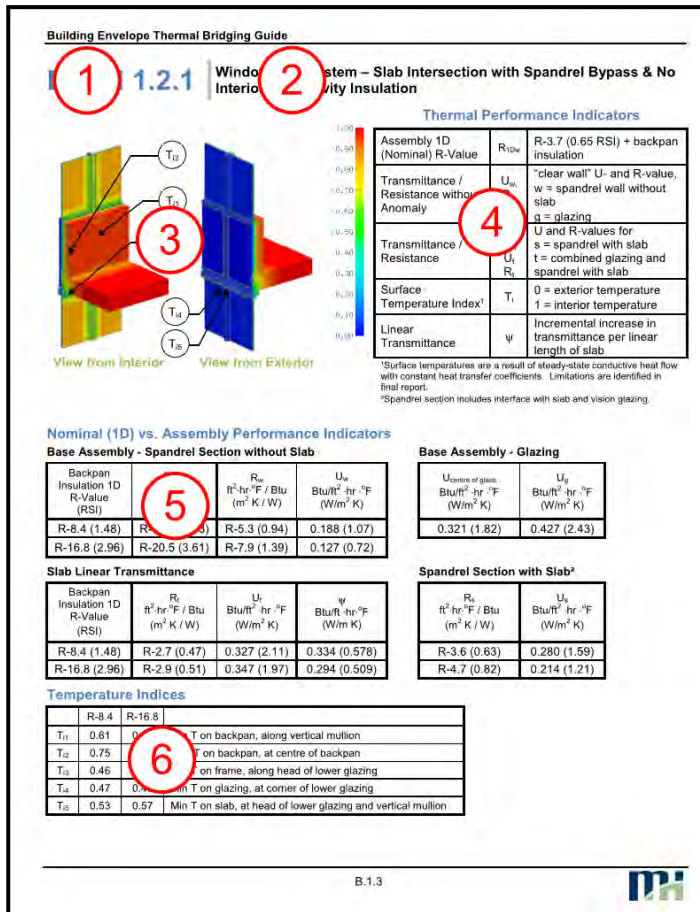

1) Detail Name

Each detail is named based on position within the catalogue index. The first number 1.x.x indicates the construction type according to the main index (ie 1 is Window-Wall, 5 is Steel Framed, 8 is Wood Framed etc). The second number x.1.x indicates detail group (ie. 1 is clear field values, 2 may be all slabs and 3 may be all parapets). The last number x.x.1. is simply the order in which the detail appears within that grouping (ie slab detail 1, slab detail 2 etc).

2) Detail Description

A basic description is included that denotes the construction system or type, along with additional detail identifiers such as limited dimension information, transmittance type and insulation locations

3) Thermal Image

An isometric thermal image from the interior and from the exterior is provided, along with a non-dimensionalized temperature scale and key locations for temperature indices, see condensation indices below. While temperatures could be read off these images, they are meant to give a general look at where the areas of high heat flow are.

4) Thermal Performance Legend

A thermal performance legend is provided denoting terms and subscripts for the thermal values that follow.

5) Thermal Values

The thermal data sheets contain several types of thermal performance indicators. If one or more assemblies are present on a detail, there will typically be multiple tables present, one for each assembly and one for the averaged values for all the assemblies combined. For clear field thermal data sheets, they typically have all the information contained within one table, however for curtain wall and window wall assembly clear field thermal data sheets; they also include the glazing data. In these instances, the spandrel clear field value and glazing values are in two separate tables, along with a combined assembly that is an average of the glazing and spandrel combined.

For interface detail thermal data sheets, each type of interface detail present in a single assembly has their own table, along with a separate table for the clear field values. There may be multiple ways the clear field values are presented. If there is only one clear field assembly, all values for the detail are given in a single table and the clear field values are presented as U_o and R_o . If there are multiple clear field assemblies or multiple interface transmittances in a single detail, the clear field values for each clear field assembly will be presented in a "Base Assembly" table. This is usually the case when there are glazing assemblies involved.

The thermal values provided in these tables are as follows:

- Insulation 1D R-value is the value of insulation if it is varied within the model. This is typically the exterior insulation or backpan insulation amount.
- R_{1D} is the combined thermal resistance of all the materials in a clear field assembly. This is the value of the assembly if there were absolutely no thermal bridging.
- R_o and U_o is the clear field thermal resistance and transmittance when there is only one base clear field assembly.
- R_x and U_x is the thermal resistance and transmittance for base assembly “X” when there are multiple clear field assemblies. Be aware of the subscripts given in the Thermal Performance legend. The subscript may not always represent a clear field assembly value.
- $U_{\text{center of glass}}$ and U_g are the thermal transmittances through the 1D center of glass and the overall glazing assembly respectively.
- R and U are modelled assembly thermal resistance and transmittance that include the effects of interface details for the specific size of the modeled assembly. There may be additional subscripts if the assembly contains multiple interface details, please be aware of the subscript labels given in the Thermal Performance Legend. This is important for details with glazing, such as window wall and curtain wall. The thermal values for the combined assembly with spandrel and glazing may be wanted, however as glazing can be dealt with separately, most designers will only want the information on the spandrel, therefore the spandrel only values with the slab are given separately.
- Ψ is the linear transmittance value. There may be additional subscripts if there are multiple interface details within one assembly
- X is the point transmittance value. There may be additional subscripts if there are multiple interface details within one assembly
- T_{ix} is the condensation indice for location x

6) Condensation Indices

The thermal data sheets also provide surface temperatures of assembly components that could be exposed to interior air to help locate potential areas of risk for condensation. In order to be applicable for any climate (varying indoor and outdoor temperatures), the temperatures are non-dimensionalized into a temperature index, T_i , as shown below

$$T_i = \frac{T_{\text{surface}} - T_{\text{outside}}}{T_{\text{inside}} - T_{\text{outside}}}$$

The index is the ratio of the surface temperature relative to the interior and exterior temperatures. The temperature index has a value between 0 and 1, where 0 is the exterior temperature and 1 is the interior temperature. If T_i is known, the above equation can be rearranged for T_{surface} . Note that these not meant as absolute temperatures and are only given as guidance on potential regions of condensation. There are many factors that can affect the formation of condensation that are not included in the modeling. For more discussion, see section 5.3 of ASHRAE 1365-RP.

7) Window-Wall Systems

Window-wall systems integrate vision glazing, opaque spandrels, and intermediate floor bypasses into their systems, making it difficult to differentiate the thermal performance of these sections. Below is a figure to help clarify how different sections are identified in the thermal bridging details.

For the floor-to-floor vision section scenario the bypass linear transmittance Ψ is compared to a spandrel clear wall section of the same dimension but with regular mullions in place of the deflection header and without the impact of the slab.

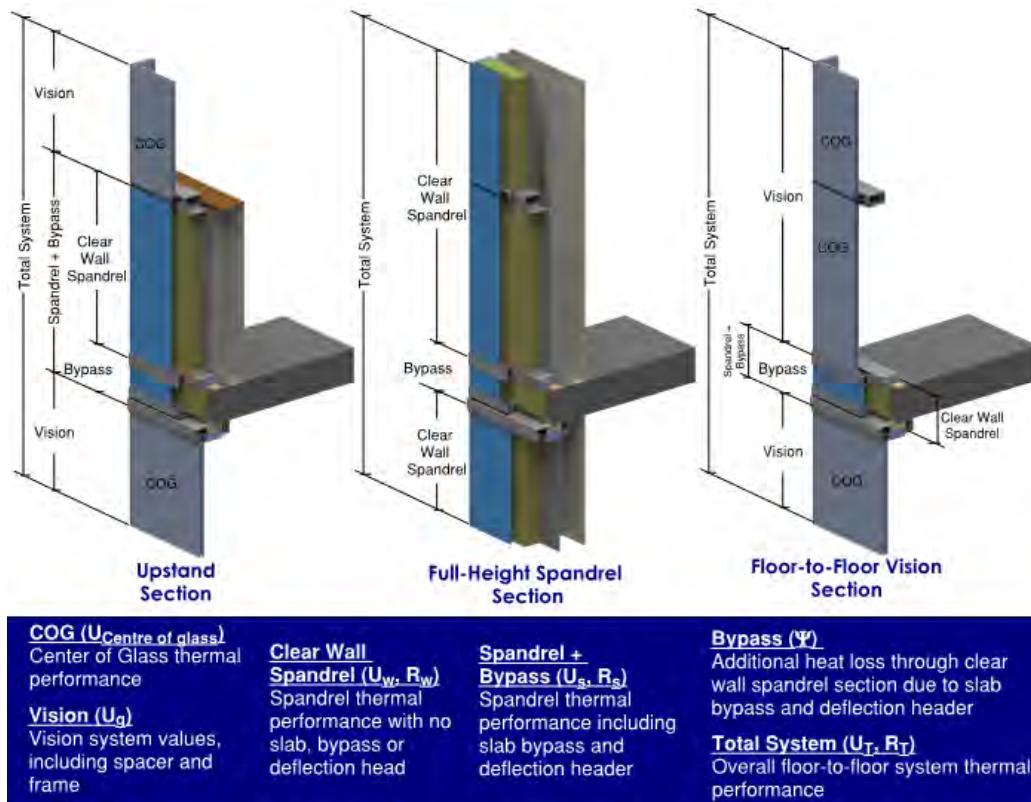

8) At-Ground Transitions

Some details contain at-grade transitions. The Ψ -value can be used like any other linear transmittance and it represents the incremental heat flow between the wall and foundation assembly. While heat flow through the wall assembly is based on heat flow per area (U-value), heat flow at foundation assemblies (slab on grade or below grade) is calculated by L-value based on ISO 10211: 2007. The L-value is simply the overall heat flow of the slab on grade per unit length of the slab perimeter. It is based on the assumption that the overall steady state heat flow through slab on grade is dominated by the perimeter, similar to F-factors referenced in ASHRAE 90.1.

Wall and floor junctions with slab on grade are still characterized by linear transmittance Ψ . The linear transmittance at wall to floor junctions are calculated by subtracting the L-value of the overall assembly by the L-value of the slab and thermal transmittance of the clear wall per unit width as shown by the equation below:

$$\Psi = L_{2Dt} - L_{2Df} - U_{ow} * H_w$$

Where:

- Ψ = Linear transmittance of wall/ slab on grade transition
- L_{2Dt} = Heat flow of overall assembly per unit length of slab perimeter
- L_{2Df} = Heat flow of slab edge per unit length of slab perimeter
- U_{ow} = U-value of the clear wall
- H_w = Height of the clear wall in the overall modelled assembly

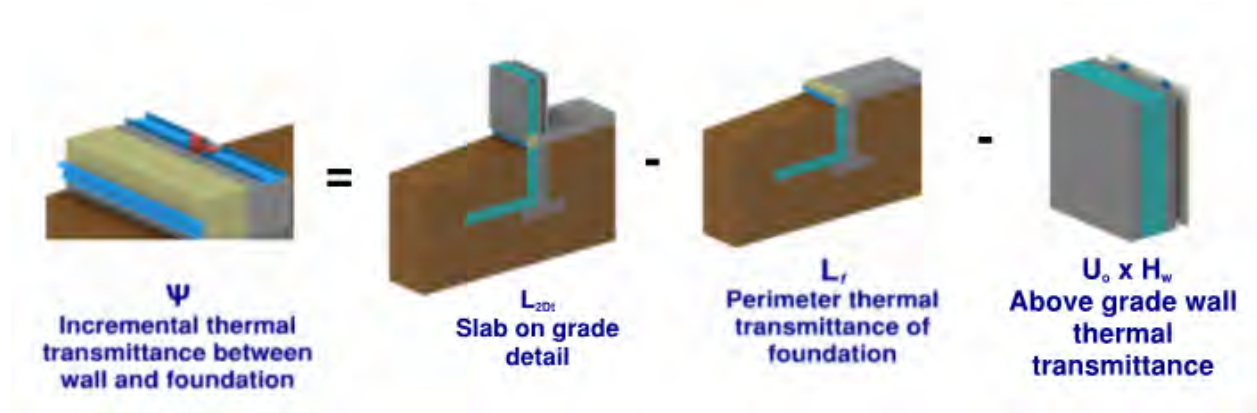

9) PDF Version

With the PDF version of the catalogue, each entry in the catalogue index is linked to each construction section. Within each section, there is an additional index for the details, which are also linked directly to each detail thermal sheet. To return to the index, simply click on the Building Envelope Thermal Bridging Guide header.

1.0 Window Wall

Detail 1.1.1	B.1.1
Window Wall System – Spandrel Panel Clear Wall with No Interior Stud Cavity Insulation	
Detail 1.1.2	B.1.2
Window Wall System – Spandrel Panel Clear Wall with Interior Sprayfoam Insulation	
Detail 1.1.3	B.1.3
Window Wall System – Full Height Spandrel with no Interior Stud Cavity Insulation	
Detail 1.1.4	B.1.4
Window Wall System – Full Height Spandrel with Interior Spray Foam Insulation	
Detail 1.2.1	B.1.5
Window Wall System – Intermediate Floor Intersection with Spandrel Bypass & No Interior Stud Cavity Insulation	
Detail 1.2.2	B.1.6
Window Wall System – Intermediate Floor Intersection with Spandrel Bypass & Interior Sprayfoam Insulation	
Detail 1.2.3	B.1.7
Window Wall System with 3' x 3' Spandrel Section – AIM Applications at Intermediate Floor Intersection	
Detail 1.2.4	B.1.8
Window Wall System – Triple Glazed Insulated Frame at Slab Intersection with Improved Spandrel Bypass & No Interior Stud Cavity Insulation	
Detail 1.2.5	B.1.9
Window Wall System – Full Height Spandrel at Slab Intersection with Spandrel Bypass & No Interior Stud Cavity Insulation	
Detail 1.2.6	B.1.10
Window Wall System – Full Height Spandrel at Slab Intersection with Spandrel Bypass & Interior Sprayfoam Insulation	
Detail 1.2.7	B.1.11
Window Wall System – Full Height Insulated Frame at Slab Intersection with Improved Spandrel Bypass & No Interior Stud Cavity Insulation	
Detail 1.2.8	B.1.12
Window Wall System – Full Height Insulated Frame at Slab Intersection with Hybridized Clipped Spandrel & No Interior Stud Cavity Insulation	
Detail 1.2.9	B.1.13
Window Wall System with Upstand Spandrel Section – Intermediate Floor Intersection with Spandrel Bypass and no Interior Stud Cavity Insulation	

Detail 1.2.10	B.1.14
Window Wall System with Full Height Vision Section – Intermediate Floor Intersection with Spandrel Bypass and no Interior Stud Cavity Insulation	
Detail 1.3.1	B.1.15
Window Wall System – Un-insulated Concrete Parapet & Roof Intersection	
Detail 1.3.2	B.1.16
Window Wall System – Partially Insulated Concrete Parapet & Roof Intersection	
Detail 1.4.1	B.1.17
Window Wall System – Inside Corner with Spandrel to Vision Transition & No Interior Stud Cavity Insulation	
Detail 1.4.2	B.1.18
Window Wall System – Inside Corner with Spandrel to Vision Transition & Interior Sprayfoam Insulation	
Detail 1.5.1	B.1.19
Window Wall System with Insulated Spandrel Panel – Uninsulated Interior Concrete Wall and Intermediate Floor Intersection	
Detail 1.5.2	B.1.20
Window Wall System with Insulated Spandrel Panel – Insulated Interior Concrete Wall and Intermediate Floor Intersection	

Detail 1.1.1

Window Wall System – Spandrel Panel Clear Wall with No Interior Stud Cavity Insulation

Thermal Performance Indicators

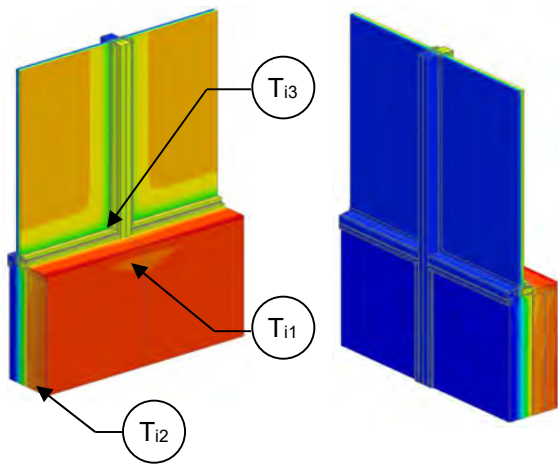

View from Interior

View from Exterior



Assembly 1D (Nominal) R-Value	R_{1D}	R-3.2 (0.55 RSI) + backpan insulation
Transmittance / Resistance	U_w, R_w, U_g	U-value and R-value for w = spandrel wall g = glazing, including framing
Transmittance / Resistance	U, R	U- and R-values for overall assembly
Surface Temperature Index ¹	T_i	0 = exterior temperature 1 = interior temperature

¹Assumptions and limitations for surface temperatures identified in ASHRAE 1365-RP

Nominal (1D) vs. Assembly Performance Indicators

Spandrel Section

Backpan Insulation 1D R-Value (RSI)	R_{1D} ft ² ·hr·°F / Btu (m ² K / W)	R_w ft ² ·hr·°F / Btu (m ² K / W)	U_w Btu/ft ² ·hr·°F (W/m ² K)
R-8.4 (1.48)	R-11.6 (2.04)	R-6.3 (1.11)	0.158 (0.90)
R-12.6 (2.22)	R-15.8 (2.78)	R-7.1 (1.26)	0.140 (0.80)
R-16.8 (2.96)	R-20.0 (3.52)	R-7.6 (1.33)	0.132 (0.75)

Glazing

$U_{\text{centre of glass}}$ Btu/ft ² ·hr·°F (W/m ² K)	U_g Btu/ft ² ·hr·°F (W/m ² K)
0.321 (1.82)	0.408 (2.32)

Combined Assembly

Backpan Insulation 1D R-Value (RSI)	R ft ² ·hr·°F / Btu (m ² K / W)	U Btu/ft ² ·hr·°F (W/m ² K)
R-8.4 (1.48)	R-3.2 (0.56)	0.314 (1.79)
R-12.6 (2.22)	R-3.2 (0.57)	0.308 (1.75)
R-16.8 (2.96)	R-3.3 (0.58)	0.305 (1.73)

Temperature Indices

	R8.4	R12.6	R16.8	
T_{i1}	0.63	0.64	0.65	Min T in stud cavity, on frame at backpan
T_{i2}	0.77	0.80	0.82	Max T on backpan, at center of backpan
T_{i3}	0.57	0.58	0.59	Min T on interior glazing, at corner of glazing

Detail 1.1.2

Window Wall System – Spandrel Panel Clear Wall with Interior Sprayfoam Insulation

Thermal Performance Indicators

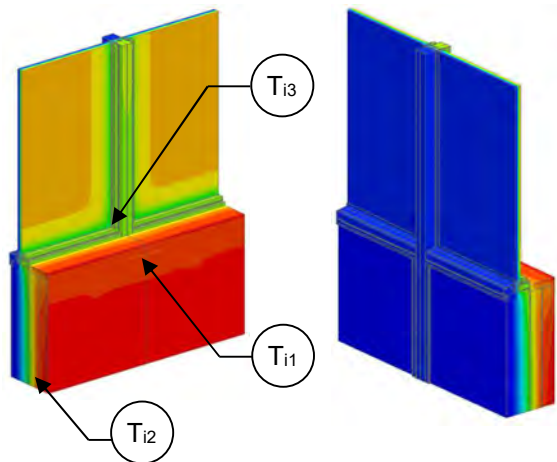

Assembly 1D (Nominal) R-Value	R _{1D}	R-15.1 (2.67 RSI) + backpan insulation
Transmittance / Resistance	U _w , R _w , U _g	U-value and R-value for w = spandrel wall g = glazing, including framing
Transmittance / Resistance	U, R	U- and R-values for overall assembly
Surface Temperature Index ¹	T _i	0 = exterior temperature 1 = interior temperature

¹Assumptions and limitations for surface temperatures identified in ASHRAE 1365-RP

View from Interior View from Exterior

Nominal (1D) vs. Assembly Performance Indicators

Clear Wall Spandrel Section

Backpan Insulation 1D R-Value (RSI)	R _{1D} ft ² ·hr·°F / Btu (m ² K / W)	R _w ft ² ·hr·°F / Btu (m ² K / W)	U _w Btu/ft ² ·hr ·°F (W/m ² K)
R-8.4 (1.48)	R-23.5 (4.15)	R-9.0 (1.59)	0.111 (0.63)
R-12.6 (2.22)	R-27.7 (4.89)	R-9.8 (1.72)	0.102 (0.58)
R-16.8 (2.96)	R-31.9 (5.63)	R-10.4 (1.82)	0.097 (0.55)

Glazing

U _{centre of glass} Btu/ft ² ·hr ·°F (W/m ² K)	U _g Btu/ft ² ·hr ·°F (W/m ² K)
0.321 (1.82)	0.408 (2.32)

Combined Assembly

Backpan Insulation 1D R-Value (RSI)	R ft ² ·hr·°F / Btu (m ² K / W)	U Btu/ft ² ·hr ·°F (W/m ² K)
R-8.4 (1.48)	R-3.4 (0.59)	0.297 (1.68)
R-12.6 (2.22)	R-3.4 (0.60)	0.293 (1.67)
R-16.8 (2.96)	R-3.4 (0.60)	0.291 (1.65)

Temperature Indices

	R8.4	R12.6	R16.8	
T _{i1}	0.74	0.75	0.76	Min T in stud cavity, on sprayfoam in line with vertical frame
T _{i2}	0.93	0.94	0.94	Max T on sprayfoam, in line with center of backpan
T _{i3}	0.53	0.54	0.54	Min T on interior glazing, at corner of glazing

Detail 1.1.3

Window Wall System – Full Height Spandrel with no Interior Stud Cavity Insulation

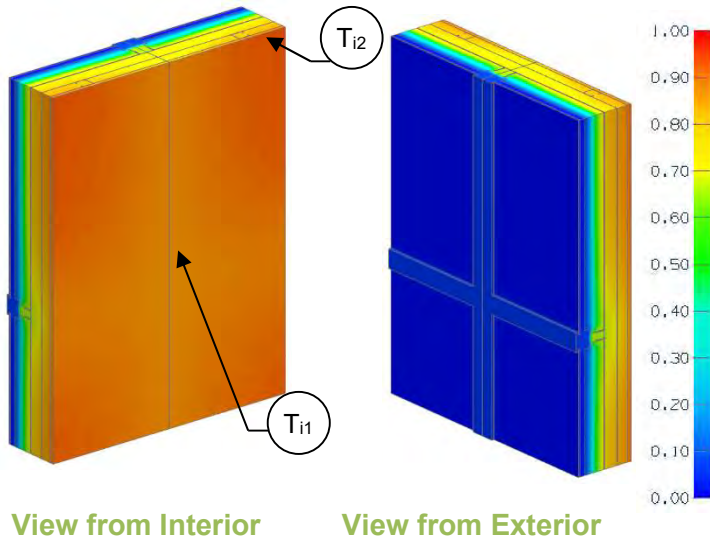

Thermal Performance Indicators

Assembly 1D (Nominal) R-Value	R_{1D}	R-3.2 (0.55 RSI) + backpan insulation
Transmittance / Resistance	$U_o, R_o,$	“clear wall” spandrel wall U- and R-value
Surface Temperature Index ¹	T_i	0 = exterior temperature 1 = interior temperature

¹Assumptions and limitations for surface temperatures identified in ASHRAE 1365-RP

View from Interior View from Exterior

Nominal (1D) vs. Assembly Performance Indicators

Backpan Insulation 1D R-Value (RSI)	R_{1D} ft ² ·hr·°F / Btu (m ² K / W)	R_o ft ² ·hr·°F / Btu (m ² K / W)	U_o Btu/ft ² ·hr ·°F (W/m ² K)
R-8.4 (1.48)	R-11.6 (2.03)	R-6.8 (1.20)	0.147 (0.84)
R-12.6 (2.22)	R-15.7 (2.77)	R-7.6 (1.34)	0.132 (0.75)
R-16.8 (2.96)	R-19.9 (3.51)	R-8.2 (1.44)	0.122 (0.69)

Temperature Indices

	R8.4	R12.6	R16.8	
T_{i1}	0.58	0.60	0.62	Min T in stud cavity, on frame at backpan
T_{i2}	0.78	0.82	0.84	Max T on backpan, at center of backpan

Detail 1.1.4

Window Wall System – Full Height Spandrel with Interior Spray Foam Insulation

Thermal Performance Indicators

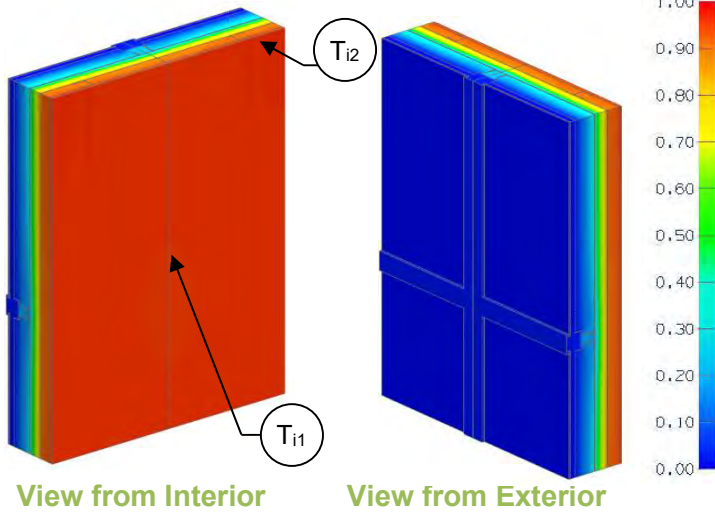

Assembly 1D (Nominal) R-Value	R_{1D}	Spandrel Wall, R-15.1 (2.67 RSI) + backpan insulation
Transmittance / Resistance	$U_o, R_o,$	“clear wall” spandrel wall U- and R-value
Surface Temperature Index ¹	T_i	0 = exterior temperature 1 = interior temperature

¹Assumptions and limitations for surface temperatures identified in ASHRAE 1365-RP

Nominal (1D) vs. Assembly Performance Indicators

Backpan Insulation 1D R-Value (RSI)	R_{1D} ft ² ·hr·°F / Btu (m ² K / W)	R_o ft ² ·hr·°F / Btu (m ² K / W)	U_o Btu/ft ² ·hr ·°F (W/m ² K)
R-8.4 (1.48)	R-23.5 (4.15)	R-18.5 (3.25)	0.054 (0.31)
R-12.6 (2.22)	R-27.7 (4.89)	R-19.4 (3.41)	0.052 (0.29)
R-16.8 (2.96)	R-31.9 (5.63)	R-20.0 (3.52)	0.050 (0.28)

Temperature Indices

	R8.4	R12.6	R16.8	
T_{i1}	0.91	0.91	0.92	Min T on sprayfoam, in line with frame
T_{i2}	0.92	0.93	0.93	Max T on sprayfoam in stud cavity

Detail 1.2.1

Window Wall System – Intermediate Floor Intersection with Spandrel Bypass & No Interior Stud Cavity Insulation

Thermal Performance Indicators

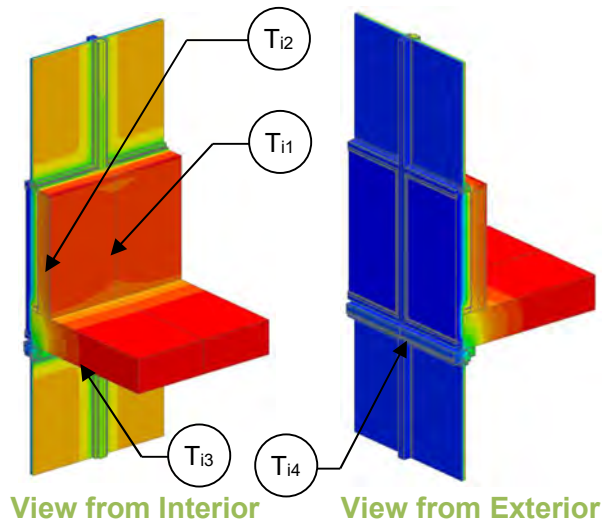

Assembly 1D (Nominal) R-Value	R_{1D}	R-3.2 (0.55 RSI) + backpan insulation
Transmittance / Resistance without Anomaly	U_w , R_w , U_g	“clear wall” U- and R-value, w = spandrel wall without slab g = glazing
Transmittance / Resistance	U_s , R_s , U_t , R_t	U and R-values for s = spandrel with slab t = combined glazing and spandrel with slab
Surface Temperature Index ¹	T_i	0 = exterior temperature 1 = interior temperature
Linear Transmittance	ψ	Incremental increase in transmittance per linear length of slab

¹Assumptions and limitations for surface temperatures identified in ASHRAE 1365-RP

²Spandrel section includes interface with slab and vision glazing.

Nominal (1D) vs. Assembly Performance Indicators

Base Assembly – Clear Wall Spandrel Section

Backpan Insulation 1D R-Value (RSI)	R_{1D} ft ² ·hr·°F / Btu (m ² K / W)	R_w ft ² ·hr·°F / Btu (m ² K / W)	U_w Btu/ft ² ·hr ·°F (W/m ² K)
R-8.4 (1.48)	R-11.6 (2.03)	R-6.3 (1.11)	0.158 (0.90)
R-12.6 (2.22)	R-15.7 (2.77)	R-7.1 (1.26)	0.140 (0.80)
R-16.8 (2.96)	R-19.9 (3.51)	R-7.6 (1.33)	0.132 (0.75)

Base Assembly - Glazing

$U_{\text{centre of glass}}$ Btu/ft ² ·hr ·°F (W/m ² K)	U_g Btu/ft ² ·hr ·°F (W/m ² K)
0.321 (1.82)	0.408 (2.32)

Slab Linear Transmittance

Backpan Insulation 1D R-Value (RSI)	R_t ft ² ·hr·°F / Btu (m ² K / W)	U_t Btu/ft ² ·hr ·°F (W/m ² K)	ψ Btu/ft ·hr ·°F (W/m K)
R-8.4 (1.48)	R-2.8 (0.49)	0.358 (2.03)	0.350 (0.606)
R-12.6 (2.22)	R-2.8 (0.50)	0.353 (2.00)	0.359 (0.622)
R-16.8 (2.96)	R-2.8 (0.50)	0.350 (1.99)	0.363 (0.628)

Spandrel Section with Slab²

R_s ft ² ·hr·°F / Btu (m ² K / W)	U_s Btu/ft ² ·hr ·°F (W/m ² K)
R-3.6 (0.64)	0.275 (1.56)
R-3.8 (0.68)	0.260 (1.48)
R-3.9 (0.70)	0.253 (1.44)

Temperature Indices

	R8.4	R12.6	R16.8	
T_{i1}	0.60	0.63	0.63	Min T in stud cavity, on frame at backpan
T_{i2}	0.75	0.78	0.80	Max T on backpan, at center of backpan
T_{i3}	0.51	0.51	0.51	Min T on interior glazing, at corner of deflection header
T_{i4}	0.54	0.54	0.54	Min T on slab, at head of lower glazing and vertical mullion

Detail 1.2.2

Window Wall System – Intermediate Floor Intersection with Spandrel Bypass & Interior Sprayfoam Insulation

Thermal Performance Indicators

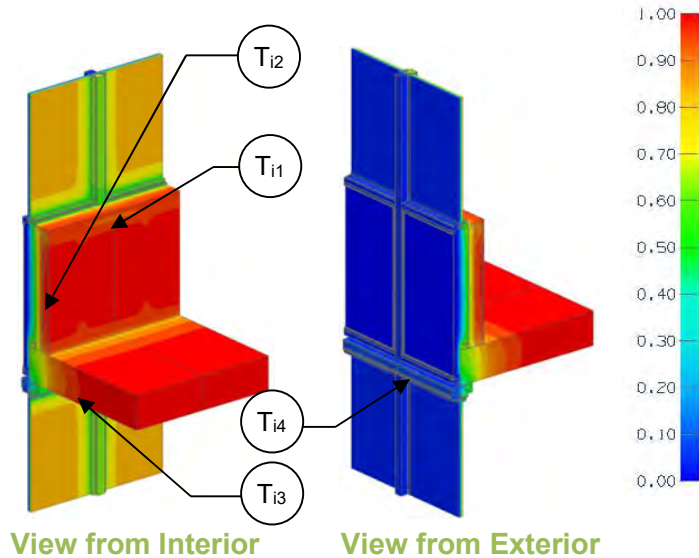

Assembly 1D (Nominal) R-Value	R_{1D}	R-15.1 (2.67 RSI) + backpan insulation
Transmittance / Resistance without Anomaly	U_w , R_w , U_g	“clear wall” U- and R-value, w = spandrel wall without slab g = glazing
Transmittance / Resistance	U_s , R_s , U_t , R_t	U and R-values for s = spandrel with slab t = combined glazing and spandrel with slab
Surface Temperature Index ¹	T_i	0 = exterior temperature 1 = interior temperature
Linear Transmittance	ψ	Incremental increase in transmittance per linear length of slab

¹Assumptions and limitations for surface temperatures identified in ASHRAE 1365-RP

²Spandrel section includes interface with slab and vision glazing.

Nominal (1D) vs. Assembly Performance Indicators

Base Assembly – Clear Wall Spandrel Section

Backpan Insulation 1D R-Value (RSI)	R_{1D} ft ² ·hr·°F / Btu (m ² K / W)	R_w ft ² ·hr·°F / Btu (m ² K / W)	U_w Btu/ft ² ·hr ·°F (W/m ² K)
R-8.4 (1.48)	R-23.5 (4.15)	R-9.0 (1.59)	0.111 (0.63)
R-12.6 (2.22)	R-27.7 (4.89)	R-9.8 (1.72)	0.102 (0.58)
R-16.8 (2.96)	R-31.9 (5.63)	R-10.4 (1.82)	0.097 (0.55)

Base Assembly - Glazing

$U_{\text{centre of glass}}$ Btu/ft ² ·hr ·°F (W/m ² K)	U_g Btu/ft ² ·hr ·°F (W/m ² K)
0.321 (1.82)	0.408 (2.32)

Slab Linear Transmittance

Backpan Insulation 1D R-Value (RSI)	R_t ft ² ·hr·°F / Btu (m ² K / W)	U_t Btu/ft ² ·hr ·°F (W/m ² K)	ψ Btu/ft ·hr ·°F (W/m K)
R-8.4 (1.48)	R-2.9 (0.51)	0.344 (1.95)	0.377 (0.652)
R-12.6 (2.22)	R-2.9 (0.52)	0.340 (1.93)	0.376 (0.651)
R-16.8 (2.96)	R-3.0 (0.52)	0.339 (1.92)	0.380 (0.658)

Spandrel Section with Slab²

R_s ft ² ·hr·°F / Btu (m ² K / W)	U_s Btu/ft ² ·hr ·°F (W/m ² K)
R-4.2 (0.74)	0.228 (1.29)
R-4.4 (0.77)	0.228 (1.29)
R-4.5 (0.79)	0.223 (1.27)

Temperature Indices

	R8.4	R12.6	R16.8	
T_{i1}	0.73	0.74	0.75	Min T in stud cavity, on sprayfoam in line with vertical frame
T_{i2}	0.93	0.93	0.94	Max T on sprayfoam, in line with center of backpan
T_{i3}	0.51	0.51	0.51	Min T on interior glazing, at corner of deflection header
T_{i4}	0.53	0.53	0.53	Min T on slab, at deflection header, in line with vertical frame

Detail 1.2.3

Window Wall System with 3' x 3' Spandrel Section – AIM Applications at Intermediate Floor Intersection

Thermal Performance Indicators

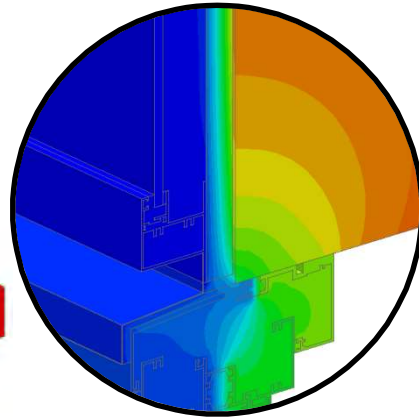
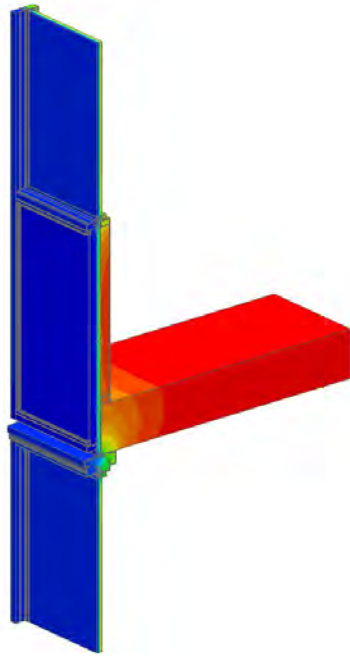

Mullion Detail



Transmittance / Resistance	U_s, R_s	Spandrel Section U-value and “Effective” R-value (including slab)
	U_g, R_g	Glazing U-value and “Effective” R-value
	U_t, R_t	Total Assembly U-value and “Effective” R-value

¹ U_t based on a window to wall ratio of 40%
AIM = Architectural Insulation Module

View from Exterior

Scenarios

Scenario	Vision Glass and Spacer	Insulation Thickness and Application	AIM Spacer/Edge Condition
A	Double Glazed with Silicone Warm Edge Spacer	0.75" (19 mm) AIM adhered to Frame	None
B	Double Glazed with Silicone Warm Edge Spacer	0.75" (19 mm) AIM adhered to Frame + 2" (51 mm) Mineral Wool in Backpan	None

Nominal (1D) vs. Assembly Performance Indicators

Scenario	Insulation R-Value (RSI)	U_s Btu/ft ² · hr · °F (W/m ² K)	R_s ft ² · hr · °F / Btu (m ² K / W)	U_g Btu/ft ² · hr · °F (W/m ² K)	R_g ft ² · hr · °F / Btu (m ² K / W)	U_t^1 Btu/ft ² · hr · °F (W/m ² K)	R_t ft ² · hr · °F / Btu (m ² K / W)
A	R-29.3 (5.16)	0.111 (0.63)	R-9.0 (1.58)	0.475 (2.70)	R-2.1 (0.37)	0.339 (1.93)	R-2.9 (0.52)
B	R-37.7 (6.64)	0.107 (0.61)	R-9.3 (1.64)	0.474 (2.69)	R-2.1 (0.37)	0.337 (1.91)	R-3.0 (0.52)

Detail 1.2.4

Window Wall System – Triple Glazed Insulated Frame at Slab Intersection with Improved Spandrel Bypass & No Interior Stud Cavity Insulation

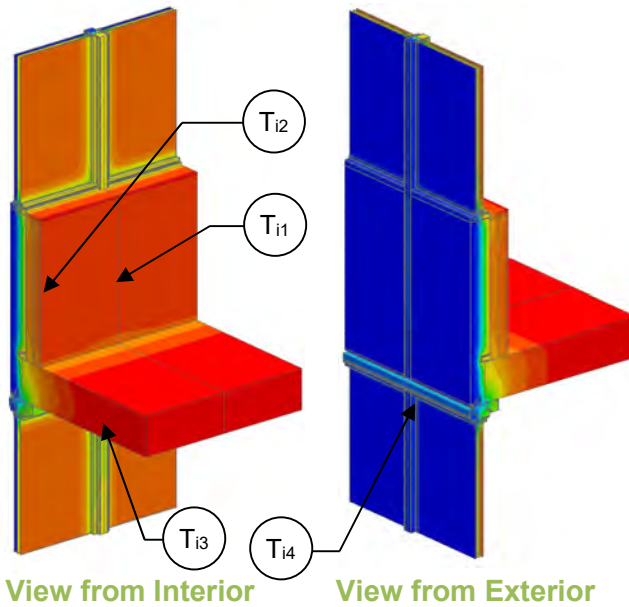

Thermal Performance Indicators

Assembly 1D (Nominal) R-Value	R_{1D}	R-3.2 (0.55 RSI) + backpan insulation
Transmittance / Resistance without Anomaly	U_w , R_w , U_g	“clear wall” U- and R-value, w = spandrel wall without slab g = glazing
Transmittance / Resistance	U_s , R_s , U_t , R_t	U and R-values for s = spandrel with slab t = combined glazing and spandrel with slab
Surface Temperature Index ¹	T_i	0 = exterior temperature 1 = interior temperature
Linear Transmittance	ψ	Incremental increase in transmittance per linear length of slab

¹Assumptions and limitations for surface temperatures identified in ASHRAE 1365-RP

²Spandrel section includes interface with slab and vision glazing. Images are for Scenario A

Scenario

Scenario	Spandrel And Deflection Header
A	Triple Glazing Break, Improved Bypass, Standard Deflection Header
B	Triple Glazing Break, Improved Bypass, Deflection Header Thermal Break in line with Slab Insulation

Nominal (1D) vs. Assembly Performance Indicators

Base Assembly – Clear Wall Spandrel Section

Backpan Insulation 1D R-Value (RSI)	R_{1D} ft ² ·hr·°F / Btu (m ² K / W)	R_w ft ² ·hr·°F / Btu (m ² K / W)	U_w Btu/ft ² ·hr·°F (W/m ² K)
R-12.6 (2.22)	R-15.7 (2.77)	R-8.4 (1.48)	0.119 (0.68)

Base Assembly - Glazing

$U_{\text{centre of glass}}$ Btu/ft ² ·hr·°F (W/m ² K)	U_g Btu/ft ² ·hr·°F (W/m ² K)
0.143 (0.81)	0.250 (1.42)

Slab Linear Transmittance

Scenario	Backpan Insulation 1D R-Value (RSI)	R_t ft ² ·hr·°F / Btu (m ² K / W)	U_t Btu/ft ² ·hr·°F (W/m ² K)	ψ Btu/ft·hr·°F (W/m K)
A	R-12.6 (2.22)	R-4.2 (0.73)	0.241 (1.37)	0.321 (0.555)
B	R-12.6 (2.22)	R-4.7 (0.82)	0.214 (1.21)	0.104 (0.181)

Spandrel Section with Slab²

R_s ft ² ·hr·°F / Btu (m ² K / W)	U_s Btu/ft ² ·hr·°F (W/m ² K)
R-4.4 (0.78)	0.226 (1.28)
R-6.5 (1.14)	0.154 (0.87)

Temperature Indices

	A	B	
T_{i1}	0.69	0.70	Min T in stud cavity, on frame at backpan
T_{i2}	0.81	0.83	Max T on backpan, at center of backpan
T_{i3}	0.63	0.69	Min T on interior glazing, at corner of deflection header
T_{i4}	0.66	0.79	Min T on slab, at head of lower glazing and vertical mullion

Detail 1.2.5

Window Wall System – Full Height Spandrel at Slab Intersection with Spandrel Bypass & No Interior Stud Cavity Insulation

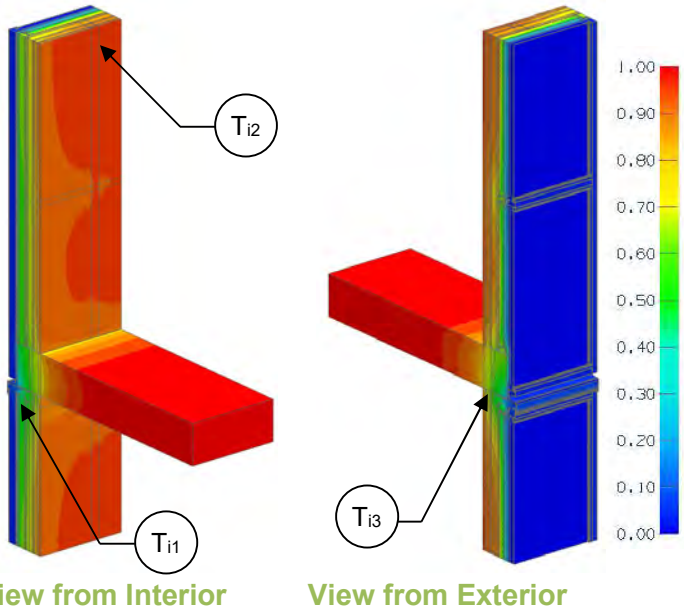

Thermal Performance Indicators

Assembly 1D (Nominal) R-Value	R_{1D}	R-3.2 (0.55 RSI) + backpan insulation
Transmittance / Resistance without Anomaly	U_w , R_w	“clear wall” spandrel wall without slab U- and R-value
Transmittance / Resistance	U_s , R_s	U and R-values for spandrel with slab
Surface Temperature Index ¹	T_i	0 = exterior temperature 1 = interior temperature
Linear Transmittance	ψ	Incremental increase in transmittance per linear length of slab

¹Assumptions and limitations for surface temperatures identified in ASHRAE 1365-RP

View from Interior

View from Exterior

Nominal (1D) vs. Assembly Performance Indicators

Base Assembly – Clear Wall Spandrel Section

Backpan Insulation 1D R-Value (RSI)	R_{1D} ft ² ·hr·°F / Btu (m ² K / W)	R_w ft ² ·hr·°F / Btu (m ² K / W)	U_w Btu/ft ² ·hr ·°F (W/m ² K)
R-8.4 (1.48)	R-11.6 (2.03)	R-6.8 (1.20)	0.147 (0.84)
R-12.6 (2.22)	R-15.7 (2.77)	R-7.6 (1.34)	0.132 (0.75)
R-16.8 (2.96)	R-19.9 (3.51)	R-8.2 (1.44)	0.122 (0.69)

Slab Linear Transmittance

Backpan Insulation 1D R-Value (RSI)	R_s ft ² ·hr·°F / Btu (m ² K / W)	U_s Btu/ft ² ·hr ·°F (W/m ² K)	ψ Btu/ft ·hr·°F (W/m K)
R-8.4 (1.48)	R-5.2 (0.91)	0.193 (1.10)	0.366 (0.634)
R-12.6 (2.22)	R-5.6 (0.98)	0.179 (1.02)	0.379 (0.655)
R-16.8 (2.96)	R-5.8 (1.03)	0.171 (0.97)	0.390 (0.675)

Temperature Indices

	R8.4	R12.6	R16.8	
T_{i1}	0.49	0.51	0.51	Min T in stud cavity, on frame at deflection header
T_{i2}	0.78	0.82	0.84	Max T on backpan, at center of backpan
T_{i3}	0.53	0.54	0.54	Min T on slab, above deflection header

Detail 1.2.6

Window Wall System – Full Height Spandrel at Slab Intersection with Spandrel Bypass & Interior Sprayfoam Insulation

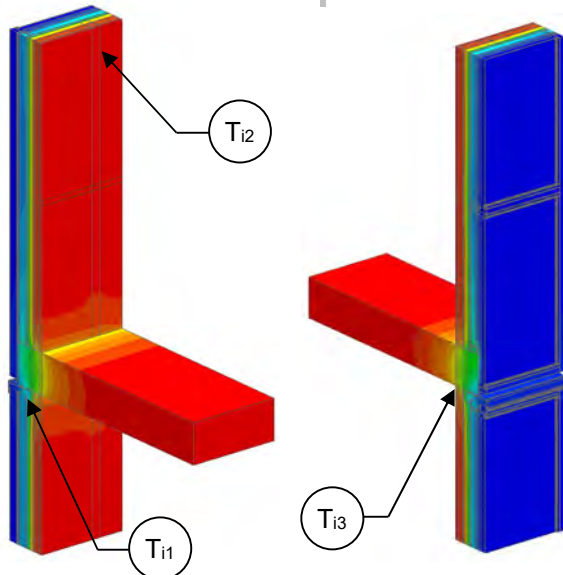

View from Interior

View from Exterior

Thermal Performance Indicators

Assembly 1D (Nominal) R-Value	R_{1D}	Spandrel Wall, R-15.1 (2.67 RSI) + backpan insulation
Transmittance / Resistance without Anomaly	U_w, R_w	“clear wall” spandrel wall without slab U- and R-value
Transmittance / Resistance	U_s, R_s	U and R-values for spandrel with slab
Surface Temperature Index ¹	T_i	0 = exterior temperature 1 = interior temperature
Linear Transmittance	ψ	Incremental increase in transmittance per linear length of slab

¹Assumptions and limitations for surface temperatures identified in ASHRAE 1365-RP

Nominal (1D) vs. Assembly Performance Indicators

Base Assembly – Clear Wall Spandrel Section

Backpan Insulation 1D R-Value (RSI)	R_{1D} ft ² ·hr·°F / Btu (m ² K / W)	R_w ft ² ·hr·°F / Btu (m ² K / W)	U_w Btu/ft ² ·hr·°F (W/m ² K)
R-8.4 (1.48)	R-23.5 (4.15)	R-18.5 (3.25)	0.054 (0.31)
R-12.6 (2.22)	R-27.7 (4.89)	R-19.4 (3.41)	0.052 (0.29)
R-16.8 (2.96)	R-31.9 (5.63)	R-20.0 (3.52)	0.050 (0.28)

Slab Linear Transmittance

Backpan Insulation 1D R-Value (RSI)	R_s ft ² ·hr·°F / Btu (m ² K / W)	U_s Btu/ft ² ·hr·°F (W/m ² K)	ψ Btu/ft·hr·°F (W/m K)
R-8.4 (1.48)	R-9.0 (1.58)	0.111 (0.63)	0.456 (0.789)
R-12.6 (2.22)	R-9.3 (1.63)	0.108 (0.61)	0.449 (0.776)
R-16.8 (2.96)	R-9.4 (1.66)	0.106 (0.60)	0.447 (0.774)

Temperature Indices

	R8.4	R12.6	R16.8	
T_{i1}	0.69	0.69	0.69	Min T on sprayfoam, in line with deflection header
T_{i2}	0.93	0.93	0.93	Max T on sprayfoam in stud cavity
T_{i4}	0.68	0.69	0.69	Min T on slab, on ceiling stud track

Detail 1.2.7

Window Wall System – Full Height Insulated Frame at Slab Intersection with Improved Spandrel Bypass & No Interior Stud Cavity Insulation

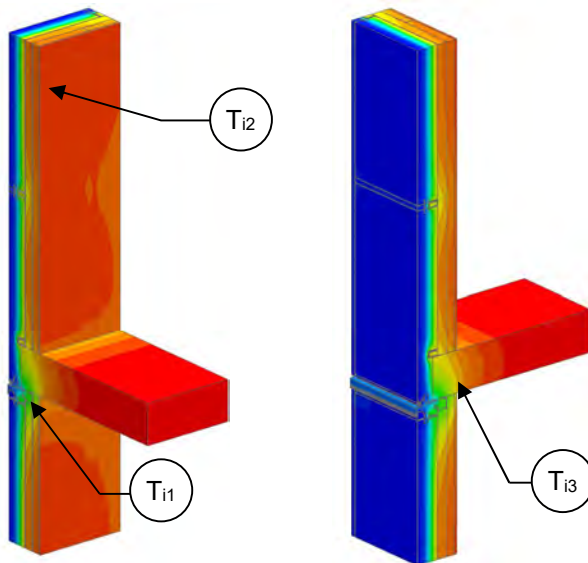

Thermal Performance Indicators

Assembly 1D (Nominal) R-Value	R_{1D}	R-3.2 (0.55 RSI) + backpan insulation
Transmittance / Resistance without Anomaly	U_w, R_w	“clear wall” spandrel wall without slab U- and R-value
Transmittance / Resistance	U_s, R_s	U and R-values for spandrel with slab
Surface Temperature Index ¹	T_i	0 = exterior temperature 1 = interior temperature
Linear Transmittance	ψ	Incremental increase in transmittance per linear length of slab

¹Assumptions and limitations for surface temperatures identified in ASHRAE 1365-RP. Images are for Scenario A.

View from Interior

View from Exterior

Scenario

Scenario	Spandrel And Deflection Header
A	Triple Glazing Break, Improved Bypass, Standard Deflection Header
B	Triple Glazing Break, Improved Bypass, Deflection Header Thermal Break in line with Slab Insulation

Nominal (1D) vs. Assembly Performance Indicators

Base Assembly – Clear Wall Spandrel Section

Backpan Insulation 1D R-Value (RSI)	R_{1D} ft ² ·hr·°F / Btu (m ² K / W)	R_w ft ² ·hr·°F / Btu (m ² K / W)	U_w Btu/ft ² ·hr ·°F (W/m ² K)
R-12.6 (2.22)	R-15.7 (2.77)	R-8.6 (1.51)	0.117 (0.66)

Slab Linear Transmittance

Scenario	Backpan Insulation 1D R-Value (RSI)	R_s ft ² ·hr·°F / Btu (m ² K / W)	U_s Btu/ft ² ·hr ·°F (W/m ² K)	ψ Btu/ft ·hr·°F (W/m K)
A	R-12.6 (2.22)	R-6.2 (1.09)	0.161 (0.92)	0.357 (0.617)
B	R-12.6 (2.22)	R-7.8 (1.37)	0.129 (0.73)	0.096 (0.166)

Temperature Indices

	A	B	
T_{i1}	0.58	0.73	Min T in stud cavity, on frame at deflection header
T_{i2}	0.83	0.84	Max T on backpan, at center of backpan
T_{i3}	0.60	0.75	Min T on slab, above deflection header

Detail 1.2.8

Window Wall System – Full Height Insulated Frame at Slab Intersection with Hybridized Clipped Spandrel & No Interior Stud Cavity Insulation

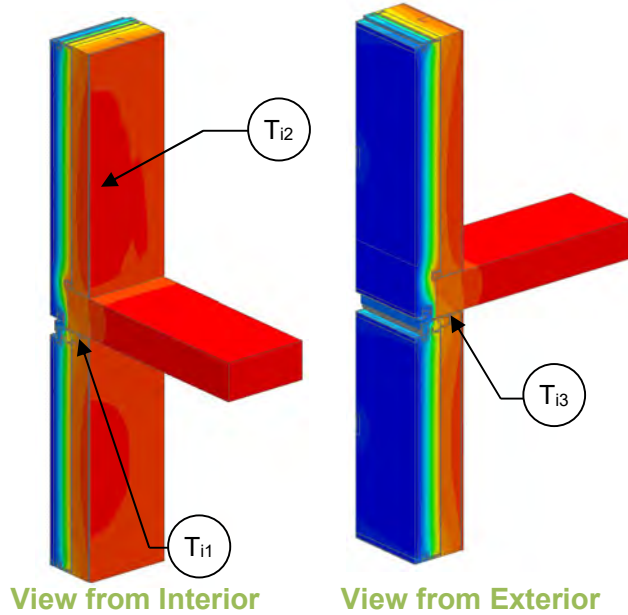

Thermal Performance Indicators

Assembly 1D (Nominal) R-Value	R_{1D}	R-3.2 (0.55 RSI) + backpan insulation
Transmittance / Resistance without Anomaly	U_w, R_w	“clear wall” spandrel wall without slab U- and R-value
Transmittance / Resistance	U_s, R_s	U and R-values for spandrel with slab
Surface Temperature Index ¹	T_i	0 = exterior temperature 1 = interior temperature
Linear Transmittance	ψ	Incremental increase in transmittance per linear length of slab

¹Assumptions and limitations for surface temperatures identified in ASHRAE 1365-RP

Nominal (1D) vs. Assembly Performance Indicators

Base Assembly – Clear Wall Spandrel Section

Backpan Insulation 1D R-Value (RSI)	R_{1D} ft ² ·hr·°F / Btu (m ² K / W)	R_w ft ² ·hr·°F / Btu (m ² K / W)	U_w Btu/ft ² ·hr ·°F (W/m ² K)
R-23.1 (4.07)	R-26.3 (4.63)	R-12.7 (2.24)	0.079 (0.45)

Slab Linear Transmittance

Backpan Insulation 1D R-Value (RSI)	R_s ft ² ·hr·°F / Btu (m ² K / W)	U_s Btu/ft ² ·hr ·°F (W/m ² K)	ψ Btu/ft ·hr ·°F (W/m K)
R-23.1 (4.07)	R-11.1 (1.96)	0.090 (0.51)	0.089 (0.154)

Temperature Indices

T_{i1}	0.80	Min T in stud cavity, on frame at deflection header
T_{i2}	0.89	Max T on backpan, at center of backpan
T_{i3}	0.81	Min T on slab, above deflection header

Detail 1.2.9

Window Wall System with Uprand Spandrel Section – Intermediate Floor Intersection with Spandrel Bypass and no Interior Stud Cavity Insulation

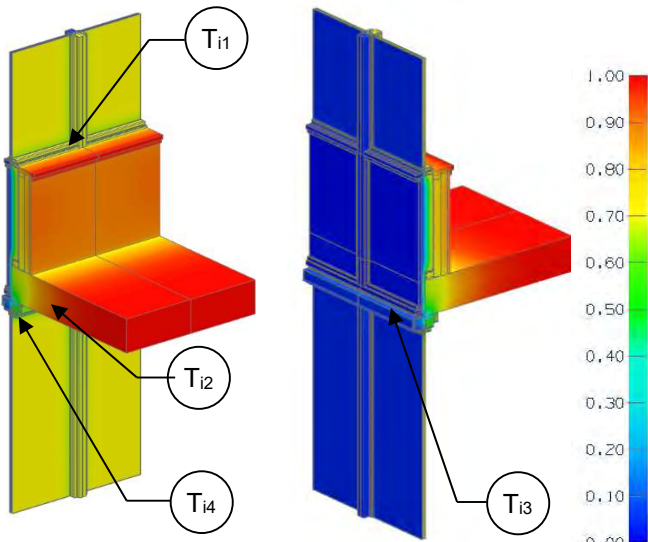

View from Interior

View from Exterior

Thermal Performance Indicators

Assembly 1D (Nominal) R-Value	R_{1D}	R-3.2 (0.56 RSI) + backpan insulation
Transmittance / Resistance without Anomaly	U_w, R_w, U_g	“clear wall” U- and R-value: w = spandrel wall without slab g = glazing
Transmittance / Resistance	U_s, R_s, U_t, R_t	U and R-values for: s = spandrel with slab t = combined glazing and spandrel with slab
Surface Temperature Index ¹	T_i	0 = exterior temperature 1 = interior temperature
Linear Transmittance	ψ	Incremental increase in transmittance per linear length of slab

¹Assumptions and limitations for surface temperatures identified in ASHRAE 1365-RP

²Spandrel section includes interface with slab and vision glazing

Nominal (1D) vs. Assembly Performance Indicators

Base Assembly – Clear Wall Spandrel Section

Backpan Insulation 1D R-Value (RSI)	R_{1D} ft ² ·hr·°F / Btu (m ² K / W)	R_w ft ² ·hr·°F / Btu (m ² K / W)	U_w Btu/ft ² ·hr·°F (W/m ² K)
R-12.6 (2.22)	R-15.7 (2.77)	R-7.8 (1.38)	0.128 (0.73)

Base Assembly Glazing

$U_{\text{centre of glass}}$ Btu/ft ² ·hr·°F (W/m ² K)	U_g Btu/ft ² ·hr·°F (W/m ² K)
0.242 (1.37)	0.329 (1.87)

Slab Linear Transmittance

Backpan Insulation 1D R-Value (RSI)	R_t ft ² ·hr·°F / Btu (m ² K / W)	U_t Btu/ft ² ·hr·°F (W/m ² K)	ψ Btu/ft·hr·°F (W/m K)
R-12.6 (2.22)	R-3.0 (0.53)	0.331 (1.88)	0.557 (0.964)

Spandrel Section with Slab²

R_s ft ² ·hr·°F / Btu (m ² K / W)	U_s Btu/ft ² ·hr·°F (W/m ² K)
R-3.0 (0.52)	0.337 (1.91)

Temperature Indices

T_{11}	0.63	Min T in stud cavity, on vertical frame at edge of backpan
T_{12}	0.46	Min T on interior glazing, at corner of vertical mullion and deflection head
T_{13}	0.51	Min T on slab, at deflection head connection
T_{14}	0.44	Min T on window frame, head at centre of window

Detail 1.2.10

Window Wall System with Full Height Vision Section – Intermediate Floor Intersection with Spandrel Bypass and no Interior Stud Cavity Insulation

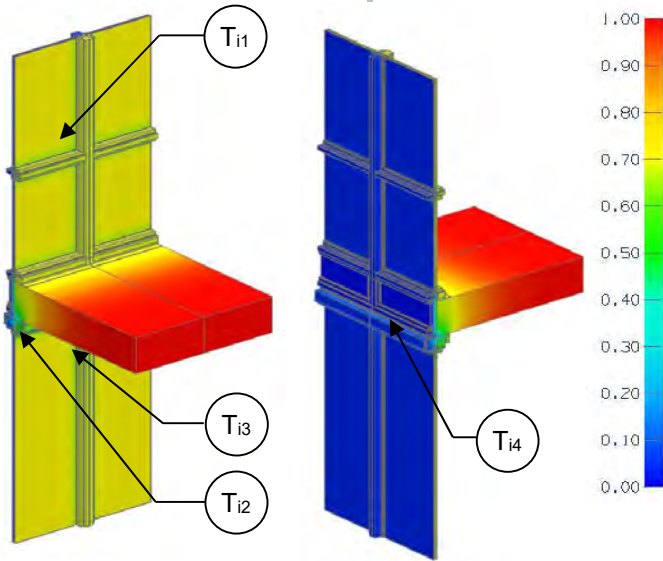

View from Interior

View from Exterior

Thermal Performance Indicators

Assembly 1D (Nominal) R-Value	R_{1D}	R-3.2 (0.56 RSI) + backpan insulation
Transmittance / Resistance without Anomaly	U_w, R_w, U_g	“clear wall” U- and R-value: w = spandrel wall without slab g = glazing
Transmittance / Resistance	U_s, R_s, U_t, R_t	U and R-values for: s = spandrel with slab t = combined glazing and spandrel with slab
Surface Temperature Index ¹	T_i	0 = exterior temperature 1 = interior temperature
Linear Transmittance	ψ	Incremental increase in transmittance per linear length of slab

¹Assumptions and limitations for surface temperatures identified in ASHRAE 1365-RP

²Bypass section includes interface with slab and vision glazing

Nominal (1D) vs. Assembly Performance Indicators

Base Assembly – Clear Wall Spandrel Section

Backpan Insulation 1D R-Value (RSI)	R_{1D} ft ² ·hr·°F / Btu (m ² K / W)	R_w ft ² ·hr·°F / Btu (m ² K / W)	U_w Btu/ft ² ·hr·°F (W/m ² K)
R-12.6 (2.22)	R-15.7 (2.77)	R-6.8 (1.20)	0.147 (0.84)

Base Assembly Glazing

$U_{\text{centre of glass}}$ Btu/ft ² ·hr·°F (W/m ² K)	U_g Btu/ft ² ·hr·°F (W/m ² K)
0.242 (1.37)	0.340 (1.93)

Slab Linear Transmittance

Backpan Insulation 1D R-Value (RSI)	R_t ft ² ·hr·°F / Btu (m ² K / W)	U_t Btu/ft ² ·hr·°F (W/m ² K)	ψ Btu/ft·hr·°F (W/m K)
R-12.6 (2.22)	R-2.6 (0.47)	0.379 (2.15)	0.497 (0.860)

Spandrel Section with Slab²

R_s ft ² ·hr·°F / Btu (m ² K / W)	U_s Btu/ft ² ·hr·°F (W/m ² K)
R-1.3 (0.23)	0.784 (4.45)

Temperature Indices

T_{i1}	0.52	Min T on interior glazing, at corner of vertical mullion and intermediate horizontal mullion
T_{i2}	0.44	Min T on window frame, head at centre of window
T_{i3}	0.46	Min T on interior glazing, at corner of deflection head and vertical mullion
T_{i4}	0.51	Min T on slab, at deflection head connection

Detail 1.3.1

Window Wall System – Un-insulated Concrete Parapet & Roof Intersection

Thermal Performance Indicators

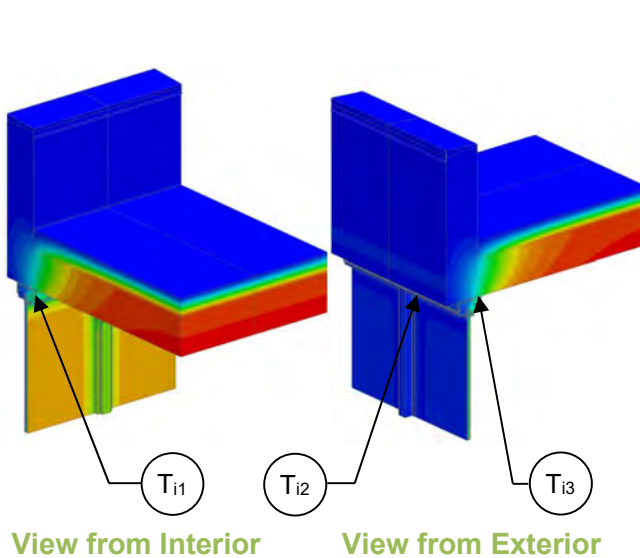

Transmittance / Resistance without Anomaly	U_r , R_r U_g	“clear field” U- and R-value, r = roof g = glazing
Transmittance / Resistance	U , R	U- and R-values for overall assembly
Surface Temperature Index ¹	T_i	0 = exterior temperature 1 = interior temperature
Linear Transmittance	ψ	Incremental increase in transmittance per linear length of parapet

¹Assumptions and limitations for surface temperatures identified in ASHRAE 1365-RP

Nominal (1D) vs. Assembly Performance Indicators

Base Assembly – Roof

Roof Insulation 1D R-Value (RSI)	R_r ft ² ·hr·°F / Btu (m ² K / W)	U_r Btu/ft ² ·hr ·°F (W/m ² K)
R-20 (3.52)	R-21.9(3.86)	0.046 (0.26)

Base Assembly - Glazing

$U_{\text{centre of glass}}$ Btu/ft ² ·hr ·°F (W/m ² K)	U_g Btu/ft ² ·hr ·°F (W/m ² K)
0.321 (1.82)	0.408 (2.32)

Parapet Linear Transmittance

R ft ² ·hr·°F / Btu (m ² K / W)	U Btu/ft ² ·hr ·°F (W/m ² K)	ψ Btu/ft ·hr·°F (W/m K)
R-3.5 (0.61)	0.288 (1.63)	0.567 (0.981)

Temperature Indices

T_{i1}	0.44	Min T on frame, along head of window wall away from centre mullion
T_{i2}	0.49	Min T on interior glazing, at corner of glazing
T_{i3}	0.48	Min T on slab, along head of window wall away from centre mullion

Detail 1.3.2

Window Wall System – Partially Insulated Concrete Parapet & Roof Intersection

Thermal Performance Indicators

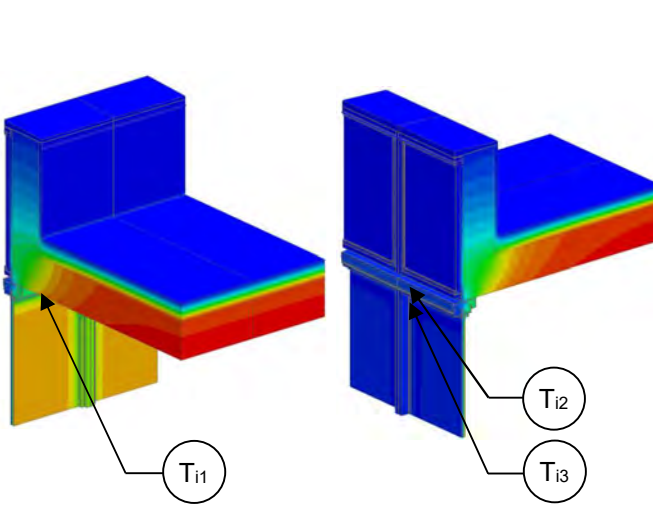

Transmittance / Resistance without Anomaly	U_r , R_r , U_g	“clear field” U- and R-value, r = roof, g = glazing
Transmittance / Resistance	U , R	U- and R-values for overall assembly
Surface Temperature Index ¹	T_i	0 = exterior temperature, 1 = interior temperature
Linear Transmittance	ψ	Incremental increase in transmittance per linear length of parapet

¹Assumptions and limitations for surface temperatures identified in ASHRAE 1365-RP

View from Interior

View from Exterior

Nominal (1D) vs. Assembly Performance Indicators

Base Assembly – Roof

Roof Insulation 1D R-Value (RSI)	R_r ft ² ·hr·°F / Btu (m ² K / W)	U_r Btu/ft ² ·hr ·°F (W/m ² K)
R-20 (3.52)	R-21.9(3.86)	0.046 (0.26)

Base Assembly - Glazing

$U_{\text{centre of glass}}$ Btu/ft ² ·hr ·°F (W/m ² K)	U_g Btu/ft ² ·hr ·°F (W/m ² K)
0.321 (1.82)	0.408 (2.32)

Glazing-Spandrel Linear Transmittance

Spandrel Insulation 1D R-Value (RSI)	R ft ² ·hr·°F / Btu (m ² K / W)	U Btu/ft ² ·hr ·°F (W/m ² K)	ψ Btu/ft ·hr ·°F (W/m K)
R-4.2 (0.74)	R-3.5 (0.61)	0.289 (1.64)	0.576 (0.996)
R-8.4 (1.48)	R-3.5 (0.61)	0.287 (1.63)	0.563 (0.975)

Temperature Indices

	R4.2	R8.4	
T_{i1}	0.47	0.47	Min T on frame, along head at edge of glazing
T_{i2}	0.49	0.50	Min T on glazing, at corner of glazing
T_{i3}	0.51	0.52	Min T on slab, along head of window wall close to centre mullion

Detail 1.4.1

Window Wall System – Inside Corner with Spandrel to Vision Transition & No Interior Stud Cavity Insulation

Thermal Performance Indicators

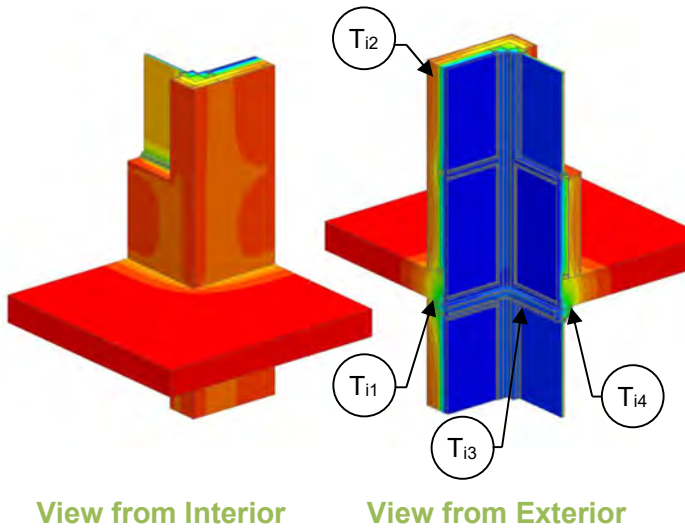

Assembly 1D (Nominal) R-Value	R _{1D}	Spandrel Wall, R-3.2 (0.56 RSI) + backpan insulation
Transmittance / Resistance without Anomaly	U _w , R _w , U _g	“clear wall” U- and R-value, w = spandrel wall without slab g = glazing
Transmittance / Resistance without Anomaly	U _s , R _s , U _t , R _t	U and R-values for s = spandrel with slab t = combined glazing, spandrel with slab and corner
Surface Temperature Index ¹	T _i	0 = exterior temperature 1 = interior temperature
Linear Transmittance	ψ _s , ψ _c	Incremental increase in transmittance per linear length of s = slab c = corner transition

¹Assumptions and limitations for surface temperatures identified in ASHRAE 1365-RP

Nominal (1D) vs. Assembly Performance Indicators

Base Assembly – Full Spandrel Wall Clear Wall

Backpan Insulation 1D R-Value (RSI)	R _{1D} ft ² ·hr·°F / Btu (m ² K / W)	R _w ft ² ·hr·°F / Btu (m ² K / W)	U _w Btu/ft ² ·hr ·°F (W/m ² K)
R-8.4 (1.48)	R-11.6 (2.04)	R-6.8 (1.20)	0.147 (0.84)
R-12.6 (2.22)	R-15.8 (2.78)	R-7.6 (1.34)	0.132 (0.75)
R-16.8 (2.96)	R-20.0 (3.52)	R-8.2 (1.44)	0.122 (0.69)

Base Assembly - Glazing

U _{centre of glass} Btu/ft ² ·hr ·°F (W/m ² K)	U _g Btu/ft ² ·hr ·°F (W/m ² K)
0.321 (1.82)	0.408 (2.32)

Full Spandrel Wall Slab Linear Transmittance

Backpan Insulation 1D R-Value (RSI)	R _s ft ² ·hr·°F / Btu (m ² K / W)	U _s Btu/ft ² ·hr ·°F (W/m ² K)	ψ _s Btu/ft ·hr·°F (W/m K)
R-8.4 (1.48)	R-5.2 (0.91)	0.193 (1.10)	0.366 (0.634)
R-12.6 (2.22)	R-5.6 (0.98)	0.179 (1.02)	0.379 (0.655)
R-16.8 (2.96)	R-5.8 (1.03)	0.171 (0.97)	0.390 (0.675)

Corner Linear Transmittance

R _t ft ² ·hr·°F / Btu (m ² K / W)	U _t Btu/ft ² ·hr ·°F (W/m ² K)	ψ _c Btu/ft ·hr·°F (W/m K)
R-2.9 (0.50)	0.350 (1.99)	0.244 (0.421)
R-2.9 (0.52)	0.341 (1.94)	0.245 (0.424)
R-3.0 (0.52)	0.336 (1.91)	0.247 (0.427)

Temperature Indices

	R8.4	R12.6	R16.8	
T _{i1}	0.51	0.53	0.53	Min T in stud cavity, at deflection header away from corner
T _{i2}	0.78	0.82	0.83	Max T on backpan, at center of backpan away from slab and glazing
T _{i3}	0.52	0.52	0.52	Min T on interior glazing, at corner of deflection header
T _{i4}	0.54	0.55	0.55	Min T on slab, at deflection header, in line with vertical frame

Detail 1.4.2

Window Wall System – Inside Corner with Spandrel to Vision Transition & Interior Sprayfoam Insulation

Thermal Performance Indicators

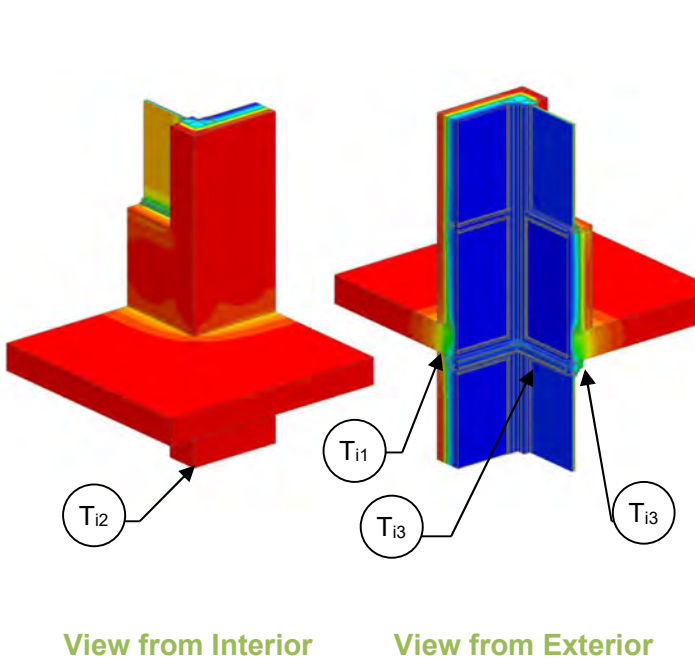

Assembly 1D (Nominal) R-Value	R_{1D}	Spandrel Wall, R-15.1 (2.67 RSI) + backpan insulation
Transmittance / Resistance without Anomaly	U_w, R_w, U_g	“clear wall” U- and R-value, w = spandrel wall without slab g = glazing
Transmittance / Resistance without Anomaly	U_s, R_s, U_t, R_t	U and R-values for s = spandrel with slab t = combined glazing, spandrel with slab and corner
Surface Temperature Index ¹	T_i	0 = exterior temperature 1 = interior temperature
Linear Transmittance	ψ_s, ψ_c	Incremental increase in transmittance per linear length of s = slab c = corner transition

¹Assumptions and limitations for surface temperatures identified in ASHRAE 1365-RP

Nominal (1D) vs. Assembly Performance Indicators

Base Assembly – Full Spandrel Wall Clear Wall

Backpan Insulation 1D R-Value (RSI)	R_{1D} ft ² ·hr·°F / Btu (m ² K / W)	R_w ft ² ·hr·°F / Btu (m ² K / W)	U_w Btu/ft ² ·hr·°F (W/m ² K)
R-8.4 (1.48)	R-23.5 (4.15)	R-18.5 (3.25)	0.054 (0.31)
R-12.6 (2.22)	R-27.7 (4.89)	R-19.4 (3.41)	0.052 (0.29)
R-16.8 (2.96)	R-31.9 (5.63)	R-20.0 (3.52)	0.050 (0.28)

Base Assembly - Glazing

$U_{\text{centre of glass}}$ Btu/ft ² ·hr·°F (W/m ² K)	U_g Btu/ft ² ·hr·°F (W/m ² K)
0.321 (1.82)	0.408 (2.32)

Full Spandrel Wall Slab Linear Transmittance

Backpan Insulation 1D R-Value (RSI)	R_s ft ² ·hr·°F / Btu (m ² K / W)	U_s Btu/ft ² ·hr·°F (W/m ² K)	ψ_s Btu/ft·hr·°F (W/m K)
R-8.4 (1.48)	R-9.0 (1.58)	0.111 (0.63)	0.456 (0.789)
R-12.6 (2.22)	R-9.3 (1.63)	0.108 (0.61)	0.449 (0.776)
R-16.8 (2.96)	R-9.4 (1.66)	0.106 (0.60)	0.447 (0.774)

Corner Linear Transmittance

R_t ft ² ·hr·°F / Btu (m ² K / W)	U_t Btu/ft ² ·hr·°F (W/m ² K)	ψ_c Btu/ft·hr·°F (W/m K)
R-3.7 (0.65)	0.270 (1.53)	0.114 (0.197)
R-3.8 (0.66)	0.266 (1.51)	0.117 (0.203)
R-3.8 (0.67)	0.265 (1.50)	0.119 (0.206)

Temperature Indices

	R8.4	R12.6	R16.8	
T_{i1}	0.67	0.68	0.68	Min T in stud cavity, on sprayfoam in line with deflection header
T_{i2}	0.97	0.97	0.98	Max T on sprayfoam, at corner away from slab
T_{i3}	0.44	0.45	0.45	Min T on interior glazing, at corner of deflection header
T_{i4}	0.57	0.57	0.57	Min T on slab, at deflection header, in line with vertical frame



Detail 1.5.1

Window Wall System with Insulated Spandrel Panel – Uninsulated Interior Concrete Wall and Intermediate Floor Intersection

Thermal Performance Indicators

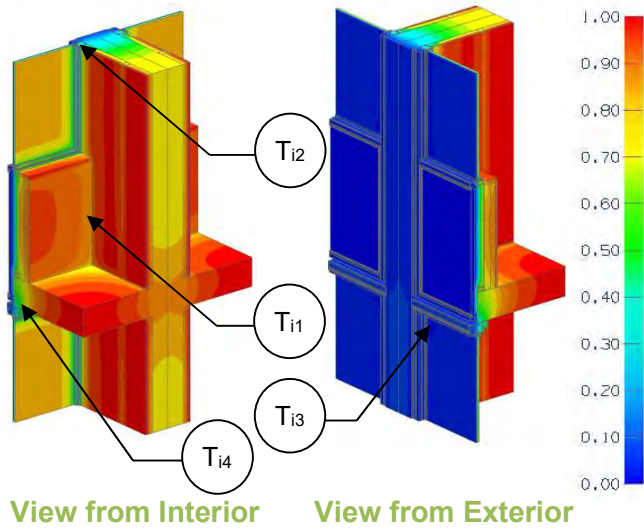

Assembly 1D (Nominal) R-Value	R_{1D}	R-3.2 (0.55 RSI) + backpan insulation
Transmittance / Resistance without Anomaly	U_w, R_w, U_g	“clear wall” U- and R-value, w = spandrel wall g = glazing
Transmittance / Resistance	U_s, R_s, U_t, R_t	U and R-values for s = spandrel with slab t = combined glazing and spandrel with vertical concrete wall and horizontal slab
Surface Temperature Index ¹	T_i	0 = exterior temperature 1 = interior temperature
Linear Transmittance	ψ_s, ψ_v	Incremental increase in transmittance per linear length of s = slab v = vertical wall projection

¹Assumptions and limitations for surface temperatures identified in ASHRAE 1365-RP

Nominal (1D) vs. Assembly Performance Indicators

Base Assembly - Spandrel Section Clear Wall

Backpan Insulation 1D R-Value (RSI)	R_{1D} ft ² ·hr·°F / Btu (m ² K / W)	R_w ft ² ·hr·°F / Btu (m ² K / W)	U_w Btu/ft ² ·hr ·°F (W/m ² K)
R-8.4 (1.48)	R-11.6 (2.03)	R-6.3 (1.11)	0.158 (0.90)
R-16.8 (2.96)	R-20.0 (3.52)	R-7.6 (1.33)	0.132 (0.75)

Base Assembly - Glazing

$U_{\text{centre of glass}}$ Btu/ft ² ·hr ·°F (W/m ² K)	U_g Btu/ft ² ·hr ·°F (W/m ² K)
0.321 (1.82)	0.408 (2.32)

Horizontal Slab Linear Transmittance

Backpan Insulation 1D R-Value (RSI)	R_s ft ² ·hr·°F / Btu (m ² K / W)	U_s Btu/ft ² ·hr ·°F (W/m ² K)	ψ_s Btu/ft ·hr ·°F (W/m K)
R-8.4 (1.48)	R-3.6 (0.64)	0.275 (1.56)	0.350 (0.606)
R-16.8 (2.96)	R-3.9 (0.70)	0.253 (1.44)	0.363 (0.628)

Vertical Wall Linear Transmittance

R_t ft ² ·hr·°F / Btu (m ² K / W)	U_t Btu/ft ² ·hr ·°F (W/m ² K)	ψ_v Btu/ft ·hr ·°F (W/m K)
R-2.4 (0.42)	0.419 (2.38)	0.386 (0.67)
R-2.5 (0.43)	0.405 (2.30)	0.476 (0.82)

Temperature Indices

	R8.4	R16.8	
T_{i1}	0.29	0.31	Min T in stud cavity, on curtain wall frame, mid height of spandrel
T_{i2}	0.37	0.38	Min T on exposed window frame, away from sill
T_{i3}	0.52	0.52	Min T on interior glazing, at corner of deflection header
T_{i4}	0.54	0.55	Min T on slab, at deflection header

Detail 1.5.2

Window Wall System with Insulated Spandrel Panel – Insulated Interior Concrete Wall and Intermediate Floor Intersection

Thermal Performance Indicators

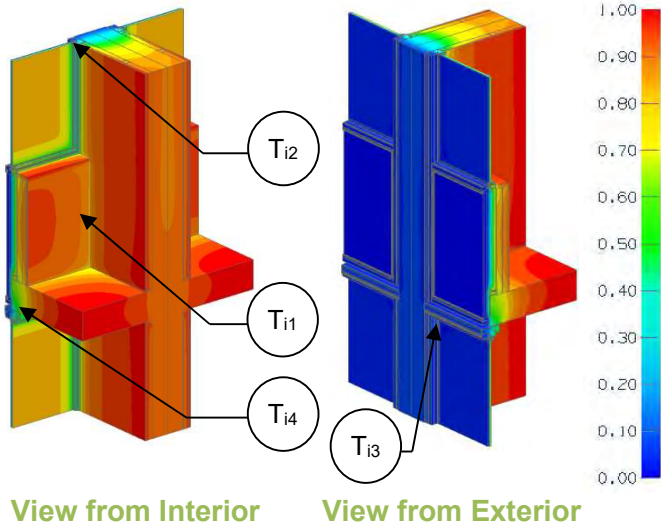

Assembly 1D (Nominal) R-Value	R_{1D}	R-3.2 (0.55 RSI) + backpan insulation
Transmittance / Resistance without Anomaly	U_w , R_w , U_g	“clear wall” U- and R-value, w = spandrel wall g = glazing
Transmittance / Resistance	U_s , R_s , U_t , R_t	U and R-values for s = spandrel with slab t = combined glazing and spandrel with vertical concrete wall and horizontal slab
Surface Temperature Index ¹	T_i	0 = exterior temperature 1 = interior temperature
Linear Transmittance	ψ_s , ψ_v	Incremental increase in transmittance per linear length of s = slab v = vertical wall projection

¹Assumptions and limitations for surface temperatures identified in ASHRAE 1365-RP

Nominal (1D) vs. Assembly Performance Indicators

Base Assembly - Spandrel Section Clear Wall

Backpan Insulation 1D R-Value (RSI)	R_{1D} ft ² ·hr·°F / Btu (m ² K / W)	R_w ft ² ·hr·°F / Btu (m ² K / W)	U_w Btu/ft ² ·hr·°F (W/m ² K)
R-8.4 (1.48)	R-11.6 (2.03)	R-6.3 (1.11)	0.158 (0.90)
R-16.8 (2.96)	R-19.9 (3.51)	R-7.6 (1.33)	0.132 (0.75)

Base Assembly - Glazing

$U_{\text{centre of glass}}$ Btu/ft ² ·hr·°F (W/m ² K)	U_g Btu/ft ² ·hr·°F (W/m ² K)
0.321 (1.82)	0.408 (2.32)

Intersection Linear Transmittance

Backpan Insulation 1D R-Value (RSI)	R_s ft ² ·hr·°F / Btu (m ² K / W)	U_s Btu/ft ² ·hr·°F (W/m ² K)	ψ Btu/ft·hr·°F (W/m K)
R-8.4 (1.48)	R-3.6 (0.64)	0.275 (1.56)	0.350 (0.606)
R-16.8 (2.96)	R-3.9 (0.70)	0.253 (1.44)	0.363 (0.628)

Vertical Wall Linear Transmittance

R_t ft ² ·hr·°F / Btu (m ² K / W)	U_t Btu/ft ² ·hr·°F (W/m ² K)	ψ_v Btu/ft·hr·°F (W/m K)
R-2.3 (0.40)	0.280 (1.59)	0.575 (1.00)
R-2.3 (0.41)	0.214 (1.21)	0.662 (1.15)

Temperature Indices

	R8.4	R16.8	
T_{i1}	0.32	0.35	Min T in stud cavity, on curtain wall frame, mid height of spandrel
T_{i2}	0.41	0.41	Min T on exposed window frame, away from sill
T_{i3}	0.52	0.52	Min T on interior glazing, at corner of deflection header
T_{i4}	0.54	0.55	Min T on slab, at deflection header

2.0 Conventional Curtain Wall

Detail 2.1.1	B.2.1
Conventional Curtain Wall System with Spandrel Panel and 3 5/8" x 1 5/8" Steel Studs (16" o.c.) – Slab Intersection & No Interior Insulation in Stud Cavity	
Detail 2.1.2	B.2.2
Conventional Curtain Wall System with Insulated Spandrel Panel and 3 5/8" x 1 5/8" Steel Stud (16" o.c.) – Intermediate Floor Intersection & Spray Foam Insulation in Stud Cavity	
Detail 2.1.3	B.2.3
Conventional Curtain Wall System with Vertical and Horizontal Pressure Plates and 5' x 5' Spandrel Section – Insulated Metal Backpan and Intermediate Floor Intersection	
Detail 2.1.4	B.2.4
Conventional Curtain Wall System with Vertical and Horizontal Pressure Plates and 5' x 5' Spandrel Section – AIM Applications and Intermediate Floor Intersection	
Detail 2.1.5	B.2.5
Conventional Curtain Wall System with Vertical and Horizontal Pressure Plates and 5' x 5' Spandrel Section – Insulated Metal Backpan and Intermediate Floor Intersection	
Detail 2.1.6	B.2.6
Conventional Curtain Wall System with 5' x 5' Spandrel Section – Alternative Glazing Methods and Intermediate Floor Intersection	
Detail 2.1.7	B.2.7
Conventional Curtain Wall System with Vertical and Horizontal Pressure Plates and 5' x 5' Spandrel Section – Insulated Backpan and Improved Glazing at Intermediate Floor Intersection	
Detail 2.1.8	B.2.8
Conventional Curtain Wall System with Vertical and Horizontal Pressure Plates and 5' x 5' Spandrel Section – AIM Applications and Improved Glazing at Intermediate Floor Intersection	
Detail 2.1.9	B.2.9
Conventional Curtain Wall System with Vertical and Horizontal Pressure Plates – Intermediate Mullion and 5' x 5' Spandrel Section – Insulated Backpan and Intermediate Floor Intersection	
Detail 2.1.10	B.2.10
Conventional Curtain Wall System with Vertical and Horizontal Pressure Plates – Intermediate Mullion and 5' x 5' Spandrel Section – AIM Applications and Intermediate Floor Intersection	

Detail 2.1.11	B.2.11
Conventional Curtain Wall System with Insulated Spandrel Panel and 3 5/8" x 1 5/8" Steel Stud (16" o.c.) – Slab Intersection & Spray Foam Insulation in Stud Cavity with Thermal Break Under Stud Cavity and at Anchors	
Detail 2.1.12	B.2.12
Conventional Curtain Wall System with Insulated Spandrel Panel and 3 5/8" x 1 5/8" Steel Studs (16" o.c.) – Slab Intersection & No Metal Back Pan	
Detail 2.1.13	B.2.13
Conventional Curtain Wall System with Insulated Spandrel Panel and 3 5/8" x 1 5/8" Steel Studs (16" o.c.) – Slab Intersection & Metal Back Pan Connected to Side of Frame	
Detail 2.1.14	B.2.14
Conventional Curtain Wall System with Vertical and Horizontal Pressure Plates and 5' x 5' Spandrel Section – Owens Corning Thermafiber Impasse System and Intermediate Floor Intersection	
Detail 2.2.1	B.2.15
Conventional Curtain Wall System with Insulated Spandrel Panel & 3 5/8" x 1 5/8" Steel Stud (16" o.c.) – Uninsulated Concrete with Spandrel & Roof Intersection	
Detail 2.2.2	B.2.16
Conventional Curtain Wall System – Insulated Spandrel & Roof Intersection	
Detail 2.2.3	B.2.17
Conventional Curtain Wall System with Insulated Spandrel Panel and 3 5/8" x 1 5/8" Steel Stud (16" o.c.) – Concrete Parapet Roof Intersection & Spray Foam Insulation in Stud Cavity	
Detail 2.2.4	B.2.18
Conventional Curtain Wall System with Insulated Spandrel Panel & 3 5/8" x 1 5/8" Steel Stud (16" o.c.) – Insulated Concrete with Spandrel & Roof Intersection	
Detail 2.3.1	B.2.19
Conventional Curtain Wall System with Insulated Spandrel Panel– Un-insulated Jamb Intersection with Vision Section	
Detail 2.3.2	B.2.20
Conventional Curtain Wall System with Insulated Spandrel Panel– Rigid Insulated Jamb Intersection with Vision Section	
Detail 2.3.3	B.2.21
Conventional Curtain Wall System with Insulated Spandrel Panel –Aerogel Insulated Jamb Intersection with Vision Section	
Detail 2.4.1	B.2.22
Conventional Curtain Wall with Insulated Spandrel Panel & 3 5/8" x 1 5/8" Steel Stud (16" o.c.) - Beam Intersection Connected to Concrete Slab	

Detail 2.4.2	B.2.23
Conventional Curtain Wall with Insulated Spandrel Panel & 5 5/8" x 1 5/8" Steel Stud (16" o.c.)- Beam Intersection Connected to Steel Beam	
Detail 2.4.3	B.2.24
Conventional Curtain Wall with Insulated Spandrel Panel & 3 5/8" x 1 5/8" Steel Stud (16" o.c.) - Canopy Beam & Gutter Intersection	
Detail 2.4.4	B.2.25
Conventional Curtain Wall with Insulated Spandrel Panel & 5 5/8" x 1 5/8" Steel Stud (16" o.c.) - Beam Intersection Connected to Steel Beam with Additional Mullions	
Detail 2.5.1	B.2.26
Conventional Curtain Wall System – At-Grade Slab Transition	

Detail 2.1.1

Conventional Curtain Wall System with Spandrel Panel and 3 5/8" x 1 5/8" Steel Studs (16" o.c.) – Slab Intersection & No Interior Insulation in Stud Cavity

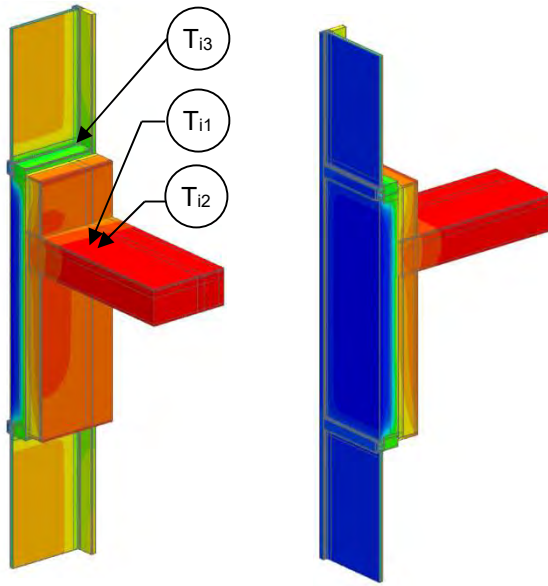

View from Interior

View from Exterior

Thermal Performance Indicators

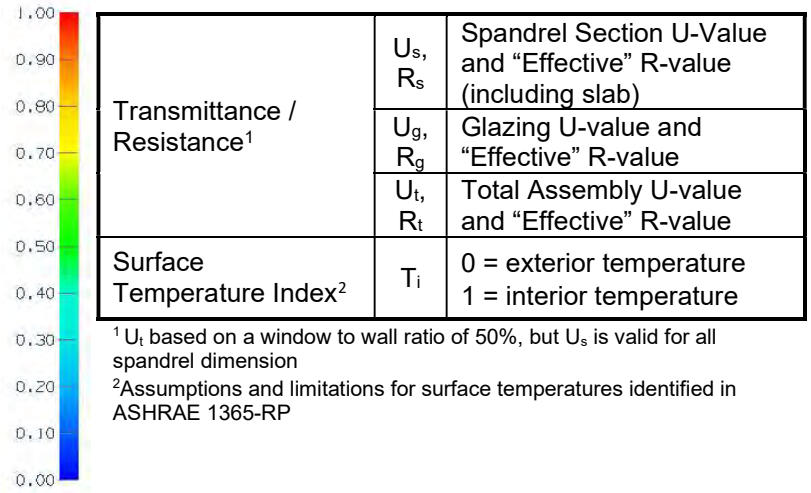

Nominal (1D) vs. Assembly Performance Indicators

Insulation R-Value (RSI)	R_s ft ² ·hr·°F / Btu (m ² K / W)	U_s Btu/ft ² ·hr ·°F (W/m ² K)	R_g ft ² ·hr·°F / Btu (m ² K / W)	U_g Btu/ft ² ·hr ·°F (W/m ² K)	R_t ft ² ·hr·°F / Btu (m ² K / W)	U_t^1 Btu/ft ² ·hr ·°F (W/m ² K)
R-8.4 (1.48)	R-3.6 (0.64)	0.274 (1.56)	R-2.2 (0.39)	0.452 (2.57)	R-2.7 (0.48)	0.366 (2.08)
R-16.8 (2.96)	R-4.8 (0.85)	0.207 (1.17)	R-2.2 (0.39)	0.452 (2.57)	R-3.0 (0.53)	0.334 (1.89)

Temperature Indices

	R8.4	R16.8	
T_{i1}	0.49	0.61	Min T on Back Pan, at the mullion, by the slab
T_{i2}	0.42	0.53	Min T on interior frame, at vertical mullion behind slab
T_{i3}	0.47	0.50	Min T on interior window, at bottom corner

Detail 2.1.2

Conventional Curtain Wall System with Insulated Spandrel Panel and 3 5/8" x 1 5/8" Steel Stud (16" o.c) – Intermediate Floor Intersection & Spray Foam Insulation in Stud Cavity

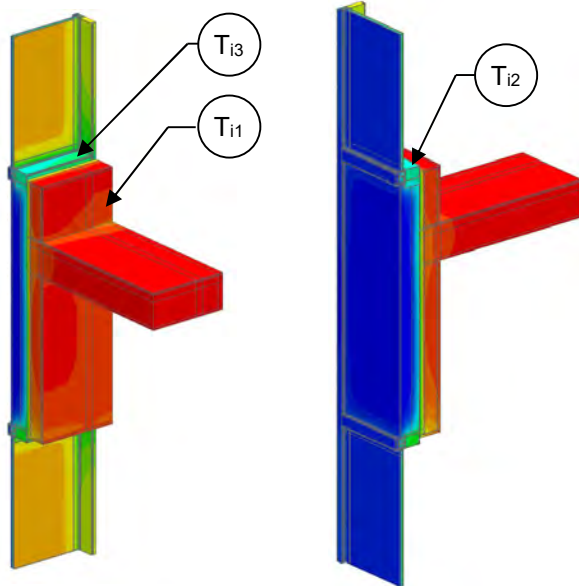

View from Interior

View from Exterior

Thermal Performance Indicators

Transmittance / Resistance ¹	U_s, R_s	Spandrel Section U-Value and "Effective" R-value (including slab)
	U_g, R_g	Glazing U-value and "Effective" R-value
	U_t, R_t	Total Assembly U-value and "Effective" R-value
Surface Temperature Index ¹	T_i	0 = exterior temperature 1 = interior temperature

¹Assumptions and limitations for surface temperatures identified in ASHRAE 1365-RP

Nominal (1D) vs. Assembly Performance Indicators

Insulation R-Value (RSI)	R_s ft ² ·hr·°F / Btu (m ² K / W)	U_s Btu/ft ² ·hr ·°F (W/m ² K)	R_g ft ² ·hr·°F / Btu (m ² K / W)	U_g Btu/ft ² ·hr ·°F (W/m ² K)	R_t ft ² ·hr·°F / Btu (m ² K / W)	U_t Btu/ft ² ·hr ·°F (W/m ² K)
R-8.4 (1.48)	R-5.4 (0.95)	0.186 (1.05)	R-2.2 (0.39)	0.452 (2.57)	R-3.1 (0.54)	0.323 (1.84)
R-16.8 (2.96)	R-6.7 (1.18)	0.149 (0.85)	R-2.2 (0.39)	0.452 (2.57)	R-3.3 (0.58)	0.306 (1.74)

Temperature Indices

	R8.4	R16.8	
T_{i1}	0.43	0.50	Min T in stud cavity, on Anchor
T_{i2}	0.48	0.49	Min T on interior frame, on sill
T_{i3}	0.44	0.45	Min T on interior window, at bottom corner

Detail 2.1.3

Conventional Curtain Wall System with Vertical and Horizontal Pressure Plates and 5' x 5' Spandrel Section – Insulated Metal Backpan and Intermediate Floor Intersection

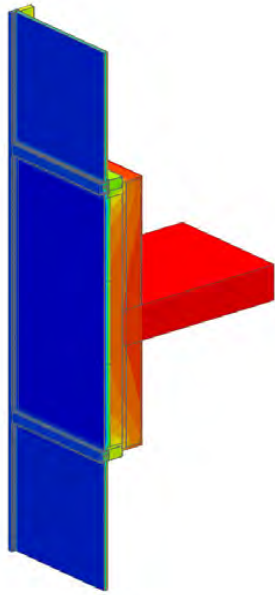

View from Exterior

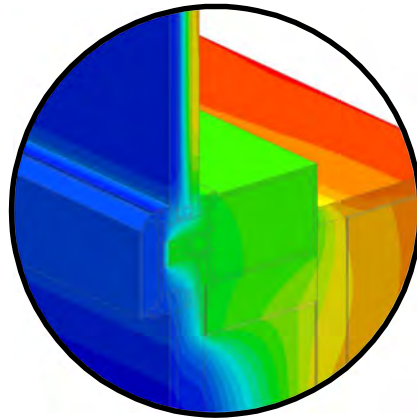

Mullion Detail

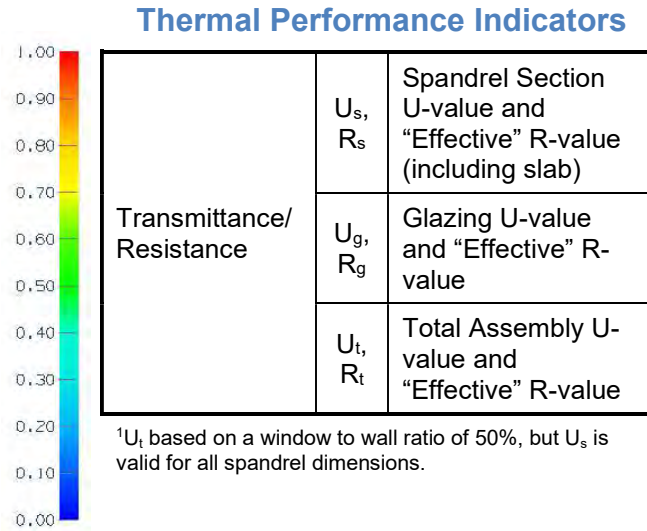

Scenario

Scenario	Vision Glass and Spacer	Insulation Thickness and Application
A	Double Glazed with Aluminum Spacer	4" (100 mm) Mineral Wool in Backpan

Nominal (1D) vs. Assembly Performance Indicators

Scenario	Insulation R-Value (RSI)	R_s ft ² ·hr·°F / Btu (m ² K / W)	U_s Btu/ft ² ·hr ·°F (W/m ² K)	R_g ft ² ·hr·°F / Btu (m ² K / W)	U_g Btu/ft ² ·hr ·°F (W/m ² K)	R_t ft ² ·hr·°F / Btu (m ² K / W)	U_t^1 Btu/ft ² ·hr ·°F (W/m ² K)
A	R-16.8 (2.96)	R-4.9 (0.86)	0.204 (1.16)	R-2.4 (0.42)	0.417 (2.37)	R-3.2 (0.57)	0.310 (1.76)

Detail 2.1.4

Conventional Curtain Wall System with Vertical and Horizontal Pressure Plates and 5' x 5' Spandrel Section – AIM Applications and Intermediate Floor Intersection

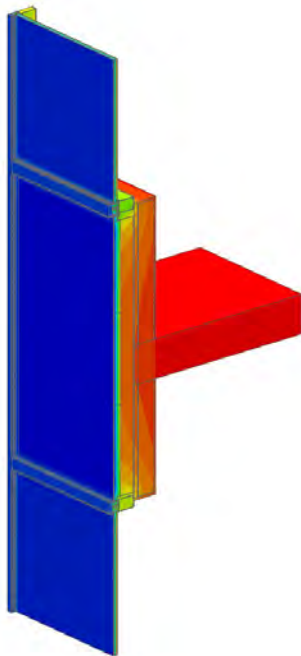

View from Exterior

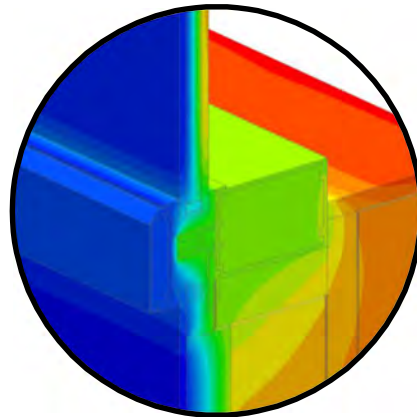

Mullion Detail

Thermal Performance Indicators



Transmittance / Resistance	U_s, R_s	Spandrel Section U-value and "Effective" R-value (including slab)
	U_g, R_g	Glazing U-value and "Effective" R-value
	U_t, R_t	Total Assembly U-value and "Effective" R-value

¹ U_t based on a window to wall ratio of 50%, but U_s is valid for all spandrel dimensions.

AIM = Architectural Insulation Module

Scenarios

Scenario	Vision Glass and Spacer	Insulation Thickness and Application	AIM Spacer/Edge Condition
A	Double Glazed with Aluminum Spacer	1.5" (38 mm) AIM adhered to Monolithic Glass	None
B	Double Glazed with Aluminum Spacer	1.5" (38 mm) AIM adhered to Insulating Glass	None
C	Double Glazed with Aluminum Spacer	0.75" (19 mm) AIM between Glass	Aluminum Spacer
D	Double Glazed with Aluminum Spacer	1" (25 mm) AIM between Metal Skins	Rigid Insulation

Nominal (1D) vs. Assembly Performance Indicators

Scenario	Insulation R-Value (RSI)	R_s ft ² ·hr·°F / Btu (m ² K / W)	U_s Btu/ft ² ·hr ·°F (W/m ² K)	R_g ft ² ·hr·°F / Btu (m ² K / W)	U_g Btu/ft ² ·hr ·°F (W/m ² K)	R_t ft ² ·hr·°F / Btu (m ² K / W)	U_t^1 Btu/ft ² ·hr ·°F (W/m ² K)
A	R-58.6 (10.32)	R-6.1 (1.08)	0.163 (0.93)	R-2.3 (0.41)	0.427 (2.42)	R-3.4 (0.60)	0.295 (1.68)
B	R-58.6 (10.32)	R-6.3 (1.10)	0.160 (0.91)	R-2.4 (0.42)	0.416 (2.36)	R-3.5 (0.61)	0.288 (1.64)
C	R-29.3 (5.16)	R-6.4 (1.12)	0.157 (0.89)	R-2.4 (0.42)	0.422 (2.40)	R-3.5 (0.61)	0.289 (1.64)
D	R-39.1 (6.89)	R-7.1 (1.25)	0.141 (0.80)	R-2.4 (0.42)	0.417 (2.37)	R-3.6 (0.63)	0.279 (1.58)

Detail 2.1.5

Conventional Curtain Wall System with Vertical and Horizontal Pressure Plates and 5' x 5' Spandrel Section – Insulated Metal Backpan and Intermediate Floor Intersection

Thermal Performance Indicators

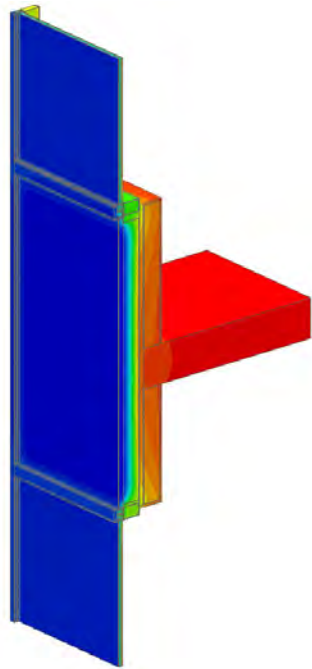

View from Exterior

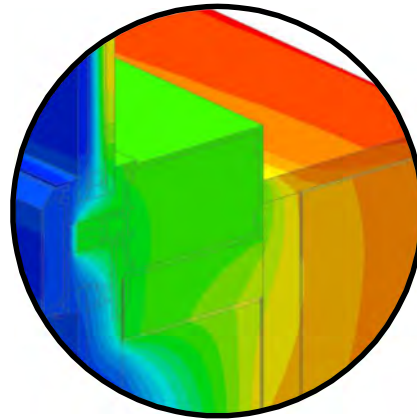

Mullion Detail



Transmittance / Resistance	U_s, R_s	Spandrel Section U-value and “Effective” R-value (including slab)
	U_g, R_g	Glazing U-value and “Effective” R-value
	U_t, R_t	Total Assembly U-value and “Effective” R-value

¹ U_t based on a window to wall ratio of 50%, but U_s is valid for all spandrel dimensions.

Scenario

Scenario	Vision Glass and Spacer	Insulation Thickness and Application
A	Double Glazed with Silicone Warm Edge Spacer	4" (100 mm) Mineral Wool in Backpan

Nominal (1D) vs. Assembly Performance Indicators

Scenario	Insulation R-Value (RSI)	R_s ft ² ·hr·°F / Btu (m ² K / W)	U_s Btu/ft ² ·hr ·°F (W/m ² K)	R_g ft ² ·hr·°F / Btu (m ² K / W)	U_g Btu/ft ² ·hr ·°F (W/m ² K)	R_t ft ² ·hr·°F / Btu (m ² K / W)	U_t^1 Btu/ft ² ·hr ·°F (W/m ² K)
A	R-16.8 (2.96)	4.9 (0.86)	0.204 (1.16)	2.5 (0.43)	0.408 (2.32)	3.3 (0.58)	0.306 (1.74)

Detail 2.1.6

Conventional Curtain Wall System with 5' x 5' Spandrel Section – Alternative Glazing Methods and Intermediate Floor Intersection

Thermal Performance Indicators

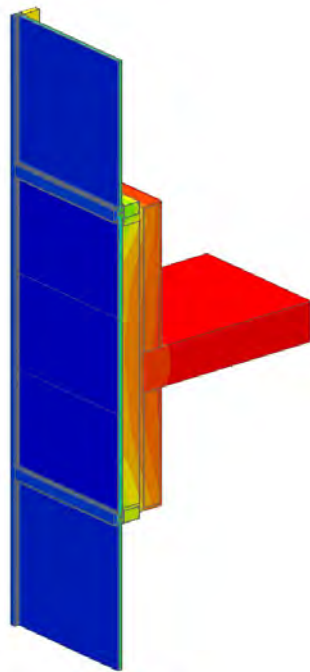

View from Exterior

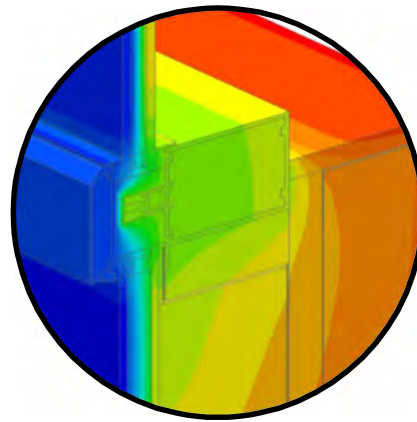

Mullion Detail



Transmittance / Resistance	U_s, R_s	Spandrel Section U-value and “Effective” R-value (including slab)
	U_g, R_g	Glazing U-value and “Effective” R-value
	U_t, R_t	Total Assembly U-value and “Effective” R-value

¹ U_t based on a window to wall ratio of 50%, but U_s is valid for all spandrel dimensions.

AIM = Architectural Insulation Module

Scenarios

Scenario	Glazing Method	Vision Glass and Spacer	Insulation Thickness and Application	AIM Spacer/Edge Condition
A	Vertical & Horizontal Pressure Plates	Double Glazed with Silicone Warm Edge Spacer	0.75" (19 mm) AIM between Glass	Silicone Warm Edge Spacer
B	Vertical Structural Silicone & Horizontal Pressure Plates	Double Glazed with Silicone Warm Edge Spacer	0.75" (19 mm) AIM between Glass + 4" (100 mm) Mineral Wool in Backpan	Silicone Warm Edge Spacer

Nominal (1D) vs. Assembly Performance Indicators

Scenario	Insulation R-Value (RSI)	R_s ft ² ·hr·°F / Btu (m ² K / W)	U_s Btu/ft ² ·hr ·°F (W/m ² K)	R_g ft ² ·hr·°F / Btu (m ² K / W)	U_g Btu/ft ² ·hr ·°F (W/m ² K)	R_t ft ² ·hr·°F / Btu (m ² K / W)	U_t^1 Btu/ft ² ·hr ·°F (W/m ² K)
A	R-29.3 (5.16)	R-6.6 (1.16)	0.151 (0.86)	R-2.4 (0.42)	0.415 (2.36)	R-3.5 (0.62)	0.283 (1.61)
B	R-46.1 (8.12)	R-8.8 (1.56)	0.113 (0.64)	R-2.6 (0.46)	0.382 (2.17)	R-4.0 (0.71)	0.249 (1.41)

Detail 2.1.7

Conventional Curtain Wall System with Vertical and Horizontal Pressure Plates and 5' x 5' Spandrel Section – Insulated Backpan and Improved Glazing at Intermediate Floor Intersection

Thermal Performance Indicators

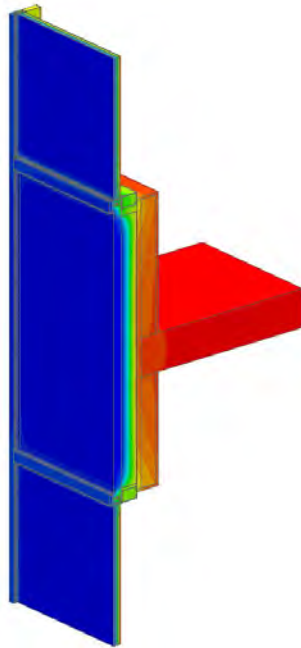

View from Exterior

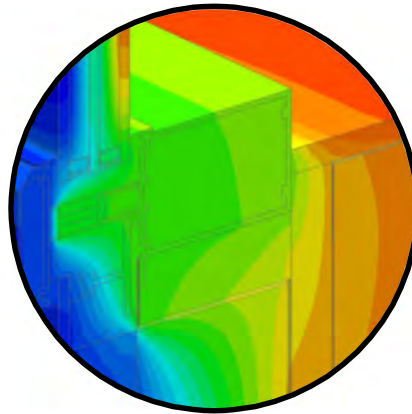

Mullion Detail



Transmittance / Resistance	U_s, R_s	Spandrel Section U-value and “Effective” R-value (including slab)
	U_g, R_g	Glazing U-value and “Effective” R-value
	U_t, R_t	Total Assembly U-value and “Effective” R-value

¹ U_t based on a window to wall ratio of 50%, but U_s is valid for all spandrel dimensions.

Scenario

Scenario	Vision Glass and Spacer	Insulation Thickness and Application
A	Triple Glazed with Aluminum Spacer	4" (100 mm) Mineral Wool in Backpan

Nominal (1D) vs. Assembly Performance Indicators

Scenario	Insulation R-Value (RSI)	R_s ft ² ·hr·°F / Btu (m ² K / W)	U_s Btu/ft ² ·hr ·°F (W/m ² K)	R_g ft ² ·hr·°F / Btu (m ² K / W)	U_g Btu/ft ² ·hr ·°F (W/m ² K)	R_t ft ² ·hr·°F / Btu (m ² K / W)	U_t^1 Btu/ft ² ·hr ·°F (W/m ² K)
A	R-16.8 (2.96)	R-5.3 (0.93)	0.189 (1.07)	R-3.5 (0.61)	0.289 (1.64)	R-4.2 (0.74)	0.239 (1.35)

Detail 2.1.8

Conventional Curtain Wall System with Vertical and Horizontal Pressure Plates and 5' x 5' Spandrel Section – AIM Applications and Improved Glazing at Intermediate Floor Intersection

Thermal Performance Indicators

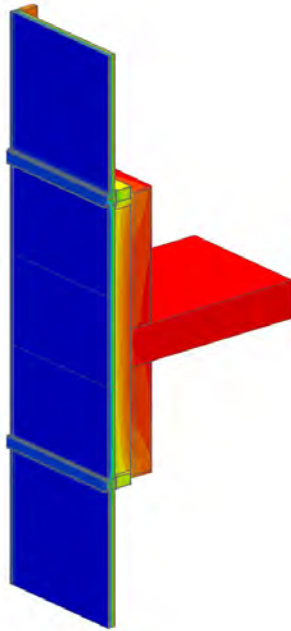

View from Exterior

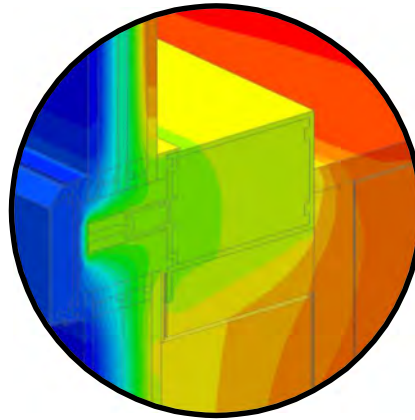

Mullion Detail



Transmittance / Resistance	U_s, R_s	Spandrel Section U-value and “Effective” R-value (including slab)
	U_g, R_g	Glazing U-value and “Effective” R-value
	U_t, R_t	Total Assembly U-value and “Effective” R-value

¹ U_t based on a window to wall ratio of 50%, but U_s is valid for all spandrel dimensions.

AIM = Architectural Insulation Module

Scenarios

Scenario	Vision Glass and Spacer	Insulation Thickness and Application	AIM Spacer/Edge Condition
A	Triple Glazed with Silicone Warm Edge Spacer	1.5" (38 mm) AIM between Glass + 4" (100 mm) Mineral Wool in Backpan	Silicone Warm Edge Spacer

Nominal (1D) vs. Assembly Performance Indicators

Scenario	Insulation R-Value (RSI)	R_s ft ² ·hr·°F / Btu (m ² K / W)	U_s Btu/ft ² ·hr ·°F (W/m ² K)	R_g ft ² ·hr·°F / Btu (m ² K / W)	U_g Btu/ft ² ·hr ·°F (W/m ² K)	R_t ft ² ·hr·°F / Btu (m ² K / W)	U_t^1 Btu/ft ² ·hr ·°F (W/m ² K)
A	R-75.4 (13.28)	R-10.5 (1.85)	0.095 (0.54)	R-4.0 (0.70)	0.250 (1.42)	R-5.8 (1.02)	0.173 (0.98)

Detail 2.1.9

Conventional Curtain Wall System with Vertical and Horizontal Pressure Plates – Intermediate Mullion and 5' x 5' Spandrel Section – Insulated Backpan and Intermediate Floor Intersection

Thermal Performance Indicators

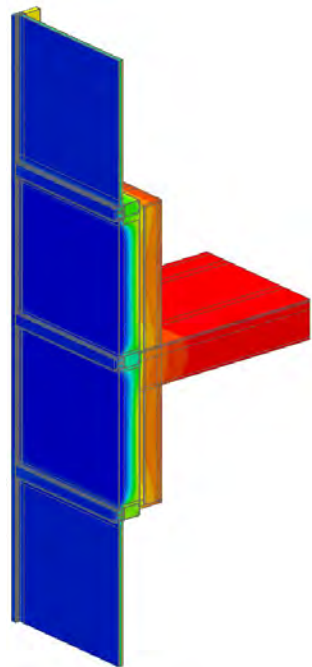

View from Exterior

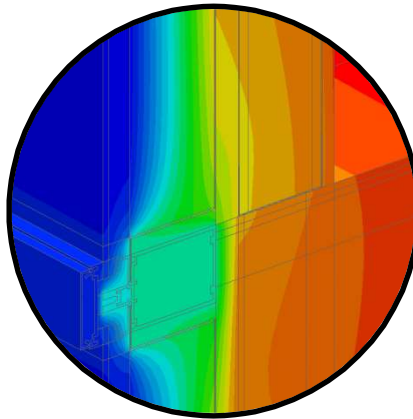

Mullion Detail



Transmittance / Resistance	U_s, R_s	Spandrel Section U-value and “Effective” R-value (including slab)
	U_g, R_g	Glazing U-value and “Effective” R-value
	U_t, R_t	Total Assembly U-value and “Effective” R-value

¹ U_t based on a window to wall ratio of 50%, but U_s is valid for all spandrel dimensions.

Scenario

Scenario	Vision Glass and Spacer	Insulation Thickness and Application
A	Double Glazed with Aluminum Spacer	4" (100 mm) Mineral Wool in Backpan

Nominal (1D) vs. Assembly Performance Indicators

Scenario	Insulation R-Value (RSI)	R_s ft ² ·hr·°F / Btu (m ² K / W)	U_s Btu/ft ² ·hr ·°F (W/m ² K)	R_g ft ² ·hr·°F / Btu (m ² K / W)	U_g Btu/ft ² ·hr ·°F (W/m ² K)	R_t ft ² ·hr·°F / Btu (m ² K / W)	U_t^1 Btu/ft ² ·hr ·°F (W/m ² K)
A	R-16.8 (2.96)	R-4.0 (0.70)	0.250 (1.42)	R-2.5 (0.44)	0.404 (2.29)	R-3.1 (0.54)	0.327 (1.86)

Detail 2.1.10

Conventional Curtain Wall System with Vertical and Horizontal Pressure Plates – Intermediate Mullion and 5' x 5' Spandrel Section – AIM Applications and Intermediate Floor Intersection

Thermal Performance Indicators

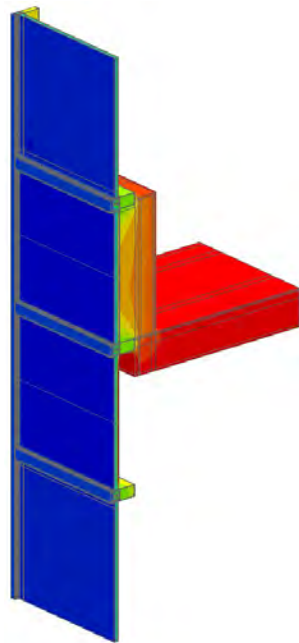

View from Exterior

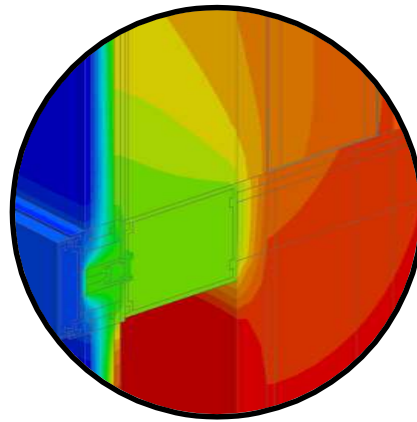

Mullion Detail



Transmittance / Resistance	U_s, R_s	Spandrel Section U-value and “Effective” R-value (including slab)
	U_g, R_g	Glazing U-value and “Effective” R-value
	U_t, R_t	Total Assembly U-value and “Effective” R-value

¹ U_t based on a window to wall ratio of 50%, but U_s is valid for all spandrel dimensions.

AIM = Architectural Insulation Module

Scenarios

Scenario	Curtain Wall Framing	Vision Glass and Spacer	Insulation Thickness and Application	AIM Spacer/Edge Condition
A	Vertical & Horizontal Pressure Plates	Double Glazed with Silicone Warm Edge Spacer	0.75" (19 mm) AIM between Glass	Silicone Warm Edge Spacer
B	Vertical Structural Silicone & Horizontal Pressure Plates	Double Glazed with Silicone Warm Edge Spacer	0.75" (19 mm) AIM between Glass	Silicone Warm Edge Spacer
C	Vertical Structural Silicone & Horizontal Pressure Plates	Double Glazed with Silicone Warm Edge Spacer	1" (25 mm) AIM between Metal Skins	Rigid Insulation
D	Vertical Structural Silicone & Horizontal Pressure Plates	Triple Glazed with Silicone Warm Edge Spacer	1.5" (38 mm) AIM between Glass	Silicone Warm Edge Spacer

Nominal (1D) vs. Assembly Performance Indicators

Scenario	Insulation R-Value (RSI)	R_s ft ² ·hr·°F / Btu (m ² K / W)	U_s Btu/ft ² ·hr ·°F (W/m ² K)	R_g ft ² ·hr·°F / Btu (m ² K / W)	U_g Btu/ft ² ·hr ·°F (W/m ² K)	R_t ft ² ·hr·°F / Btu (m ² K / W)	U_t^1 Btu/ft ² ·hr ·°F (W/m ² K)
A	R-29.3 (5.16)	R-4.6 (0.81)	0.217 (1.23)	R-2.4 (0.42)	0.414 (2.35)	R-3.1 (0.55)	0.318 (1.81)
B	R-29.3 (5.16)	R-5.4 (0.96)	0.184 (1.04)	R-2.6 (0.45)	0.390 (2.22)	R-3.5 (0.61)	0.287 (1.63)
C	R-39.1 (6.89)	R-6.0 (1.05)	0.167 (0.95)	R-2.6 (0.46)	0.385 (2.19)	R-3.6 (0.64)	0.276 (1.57)
D	R-58.6 (10.32)	R-6.1 (1.08)	0.163 (0.92)	R-4.0 (0.71)	0.250 (1.42)	R-4.9 (0.85)	0.206 (1.17)

Detail 2.1.11

Conventional Curtain Wall System with Insulated Spandrel Panel and 3 5/8" x 1 5/8" Steel Stud (16" o.c) – Slab Intersection & Spray Foam Insulation in Stud Cavity with Thermal Break Under Stud Cavity and at Anchors

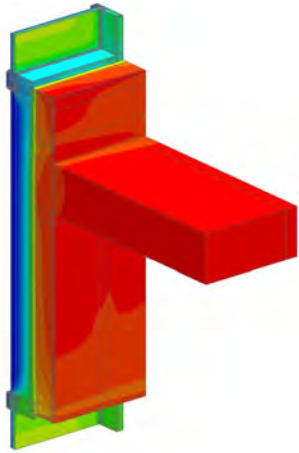

View from Interior

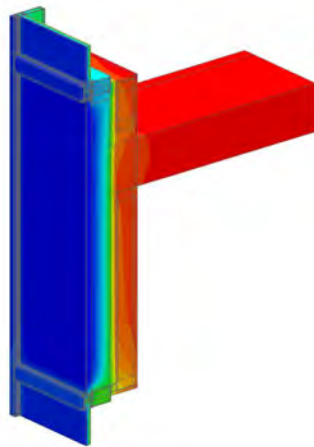

View from Exterior



Thermal Performance Indicators

Assembly 1D (Nominal) R-Value	R_{1D}	Nominal thermal resistance of spandrel section + backup wall with sprayfoam
Spandrel Transmittance/Resistance	U_s, R_s	U- and R-Value for Spandrel section only
Surface Temperature Index	T_i	0 = exterior temperature 1 = interior temperature

¹For performance of base assembly spandrel without thermal breaks, refer to Detail 2.1.2

Scenario

Scenario	Flashing and Shelf Angle
1	2" Armatherm 500 beneath stud cavity
2	2" Armatherm 500 beneath stud cavity and 3/8" FRR at support angle

Back Pan Insulation vs. Assembly Performance Indicators

Scenario	Backpan Insulation 1D R-Value (RSI)	R_{1D} ft ² ·hr·°F / Btu (m ² K / W)	R_s ft ² ·hr·°F / Btu (m ² K / W)	U_s Btu/ft ² ·hr ·°F (W/m ² K)
1	R-15 (2.64)	R-29.91 (5.26)	R-9.4 (1.66)	0.106 (0.60)
2	R-15 (2.64)	R-29.91 (5.26)	R-9.6 (1.70)	0.103 (0.59)

Detail 2.1.12

Conventional Curtain Wall System with Insulated Spandrel Panel and 3 5/8" x 1 5/8" Steel Studs (16" o.c.) – Slab Intersection & No Metal Back Pan

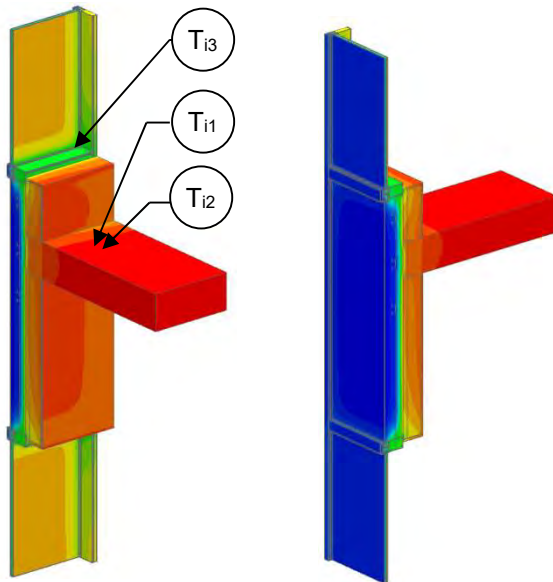

View from Interior

View from Exterior

Thermal Performance Indicators

Transmittance / Resistance ¹	U_s, R_s	Spandrel Section U-Value and "Effective" R-value (including slab)
	U_g, R_g	Glazing U-value and "Effective" R-value
	U_t, R_t	Total Assembly U-value and "Effective" R-value
Surface Temperature Index ²	T_i	0 = exterior temperature 1 = interior temperature

¹ U_t based on a window to wall ratio of 50%

² Assumptions and limitations for surface temperatures identified in ASHRAE 1365-RP

Scenario

Scenario	Mullion Wrap
A	None
B	Yes

Nominal (1D) vs. Assembly Performance Indicators

Scenario	Insulation R-Value (RSI)	R_s ft ² ·hr·°F / Btu (m ² K / W)	U_s Btu/ft ² ·hr ·°F (W/m ² K)	R_g ft ² ·hr·°F / Btu (m ² K / W)	U_g Btu/ft ² ·hr ·°F (W/m ² K)	R_t ft ² ·hr·°F / Btu (m ² K / W)	U_t^1 Btu/ft ² ·hr ·°F (W/m ² K)
A	R-8.4 (1.48)	R-4.1 (0.73)	0.241 (1.37)	R-2.2 (0.39)	0.452 (2.57)	R-2.9 (0.50)	0.350 (1.99)
B	R-8.4 (1.48)	R-4.8 (0.84)	0.209 (1.18)	R-2.2 (0.39)	0.452 (2.57)	R-3.0 (0.53)	0.335 (1.90)

Temperature Indices

	A	B	
T_{i1}	0.35	0.25	Min T on Back Pan, at the mullion, by the slab
T_{i2}	0.35	0.21	Min T on interior frame, at vertical mullion behind slab
T_{i3}	0.46	0.45	Min T on interior window, at bottom corner

Detail 2.1.13

Conventional Curtain Wall System with Insulated Spandrel Panel and 3 5/8" x 1 5/8" Steel Studs (16" o.c.) – Slab Intersection & Metal Back Pan Connected to Side of Frame

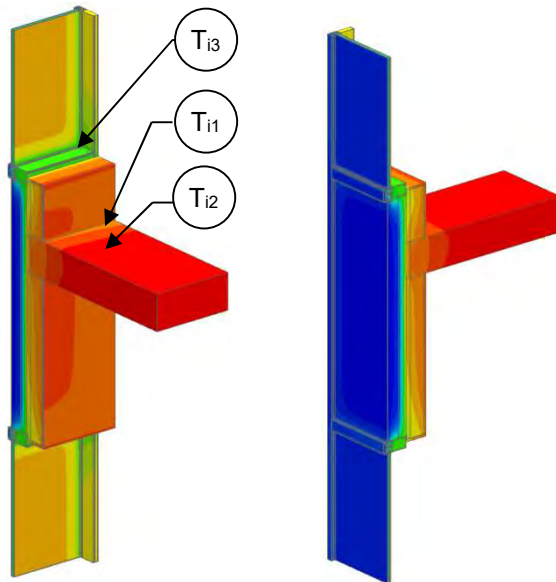

View from Interior

View from Exterior

Thermal Performance Indicators

Transmittance / Resistance ¹	U_s, R_s	Spandrel Section U-Value and "Effective" R-value (including slab)
	U_g, R_g	Glazing U-value and "Effective" R-value
	U_t, R_t	Total Assembly U-value and "Effective" R-value
Surface Temperature Index ²	T_i	0 = exterior temperature 1 = interior temperature



¹ U_t based on a window to wall ratio of 50%

² Assumptions and limitations for surface temperatures identified in ASHRAE 1365-RP

Scenario

Scenario	Location of Metal Back Pan Connected at Frame
A, B	Interior
C	Inset

Nominal (1D) vs. Assembly Performance Indicators

Scenario	Insulation R-Value (RSI)	R_s ft ² ·hr·°F / Btu (m ² K / W)	U_s Btu/ft ² ·hr ·°F (W/m ² K)	R_g ft ² ·hr·°F / Btu (m ² K / W)	U_g Btu/ft ² ·hr ·°F (W/m ² K)	R_t ft ² ·hr·°F / Btu (m ² K / W)	U_t ¹ Btu/ft ² ·hr ·°F (W/m ² K)
A	R-8.4 (1.48)	R-4.3 (0.76)	0.231 (1.31)	R-2.2 (0.39)	0.452 (2.57)	R-2.9 (0.51)	0.346 (1.96)
B	R-16.8 (2.96)	R-6.2 (1.10)	0.160 (0.91)	R-2.2 (0.39)	0.452 (2.57)	R-3.2 (0.57)	0.311 (1.77)
C	R-8.4 (1.48)	R-5.5 (0.97)	0.181 (1.03)	R-2.2 (0.39)	0.452 (2.57)	R-3.1 (0.55)	0.322 (1.83)

Temperature Indices

	A	B	C	
T_{i1}	0.52	0.65	0.64	Min T on back pan, at the mullion, by the slab
T_{i2}	0.50	0.64	0.63	Min T on interior frame, at vertical mullion behind slab
T_{i3}	0.48	0.52	0.52	Min T on interior window, at bottom corner

Detail 2.1.14

Conventional Curtain Wall System with Vertical and Horizontal Pressure Plates and 5' x 5' Spandrel Section – Owens Corning Thermafiber Impasse System and Intermediate Floor Intersection

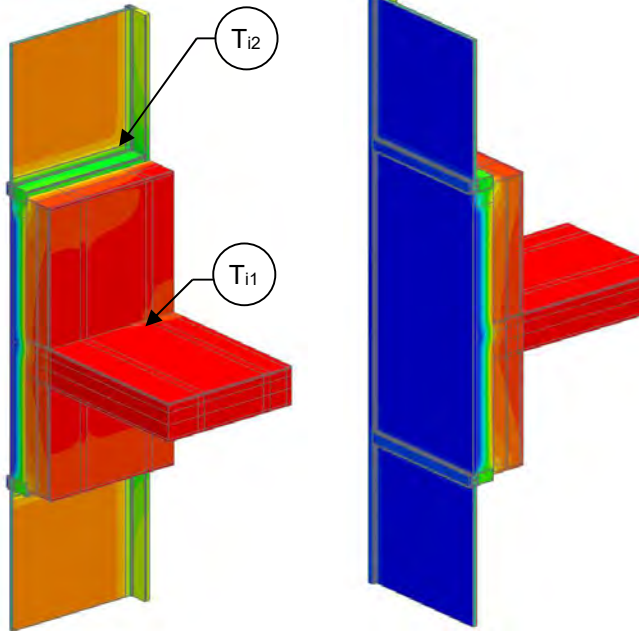

View from Interior

View from Exterior

Thermal Performance Indicators

Transmittance / Resistance	U_s, R_s	Spandrel Section U-value and "Effective" R-value (including slab)
	U_g, R_g	Glazing U-value and "Effective" R-value
	U_t, R_t	Total Assembly U-value and "Effective" R-value

¹ U_t based on a window to wall ratio of 50%, but U_s is valid for all spandrel dimensions.

Nominal (1D) vs. Assembly Performance Indicators

Insulation R-Value (RSI)	U_s Btu/ft ² · hr · °F (W/m ² K)	R_s ft ² · hr · °F / Btu (m ² K / W)	U_g Btu/ft ² · hr · °F (W/m ² K)	R_g ft ² · hr · °F / Btu (m ² K / W)	U_t^1 Btu/ft ² · hr · °F (W/m ² K)	R_t ft ² · hr · °F / Btu (m ² K / W)
R-8.4 (1.48)	0.188 (1.07)	R-5.3 (0.94)	0.455 (2.58)	R-2.2 (0.39)	0.321 (1.83)	R-3.1 (0.55)
R-16.8 (2.96)	0.129 (0.73)	R-7.8 (1.37)	0.455 (2.58)	R-2.2 (0.39)	0.292 (1.66)	R-3.4 (0.60)

Temperature Indices

	R8.4	R16.8	
T_{i1}	0.17	0.28	Min T on interior frame, at vertical mullion behind slab
T_{i2}	0.64	0.60	Min T on interior window, at bottom corner

Detail 2.2.1

Conventional Curtain Wall System with Insulated Spandrel Panel & 3 5/8" x 1 5/8" Steel Stud (16" o.c.) – Uninsulated Concrete with Spandrel & Roof Intersection

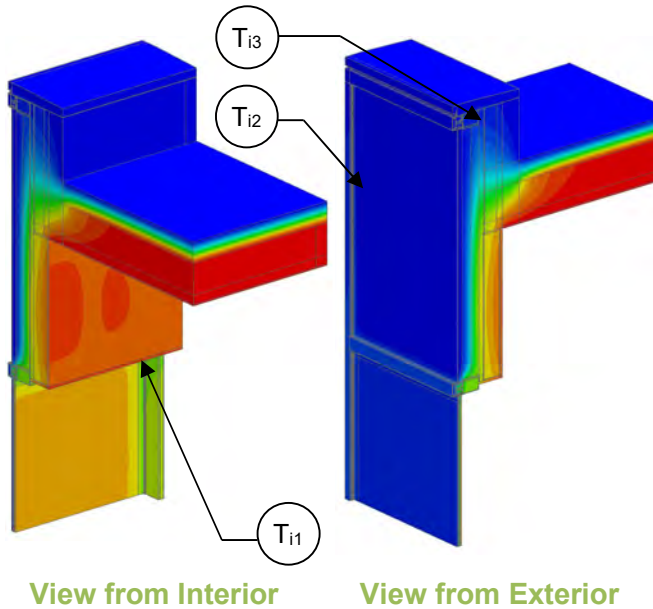

Thermal Performance Indicators

Spandrel Wall 1D (Nominal) R-Value	R _{1D}	R-3.7 (0.65 RSI) + backpan insulation
Transmittance / Resistance without Anomaly	U _r , R _r , U _s , R _s , U _g	"clear field" U- and R-value r = roof s = spandrel wall g = glazing
Transmittance / Resistance	U, R	U- and R-values for overall assembly
Surface Temperature Index ¹	T _i	0 = exterior temperature 1 = interior temperature
Linear Transmittance	ψ	Incremental increase in transmittance per linear length of parapet

¹Assumptions and limitations for surface temperatures identified in ASHRAE 1365-RP

Nominal (1D) vs. Assembly Performance Indicators

Base Assembly – Roof

Roof Insulation 1D R-Value (RSI)	R _r ft ² ·hr·°F / Btu (m ² K / W)	U _r Btu/ft ² ·hr ·°F (W/m ² K)
R-20 (3.52)	R-21.9 (3.86)	0.046 (0.26)

Base Assembly - Glazing

U _{centre of glass} Btu/ft ² ·hr ·°F (W/m ² K)	U _g Btu/ft ² ·hr ·°F (W/m ² K)
0.321 (1.82)	0.429 (2.44)

Base Assembly – Spandrel Section

Backpan Insulation 1D R-Value (RSI)	R _{1D} ft ² ·hr·°F / Btu (m ² K / W)	R _s ft ² ·hr·°F / Btu (m ² K / W)	U _s Btu/ft ² ·hr ·°F (W/m ² K)
R-8.4 (1.48)	R-12.1 (2.13)	R-6.9 (1.21)	0.145 (0.82)
R-16.8 (2.96)	R-20.5 (3.61)	R-8.8 (1.55)	0.113 (0.64)

Parapet Linear Transmittance

Spandrel Insulation 1D R-Value (RSI)	R ft ² ·hr·°F / Btu (m ² K / W)	U Btu/ft ² ·hr ·°F (W/m ² K)	ψ Btu/ft ·hr·°F (W/m K)
R-8.4 (1.48)	R-3.6 (0.63)	0.280 (1.59)	0.493 (0.853)
R-16.8 (2.96)	R-3.9 (0.68)	0.259 (1.47)	0.484 (0.838)

Temperature Indices

	R8.4	R16.8	
T _{i1}	0.54	0.58	Min T on interior frame, along head at edge of glazing
T _{i2}	0.56	0.57	Min T on concrete ceiling, at curtain wall anchor
T _{i3}	0.09	0.10	Min T on frame, at top of parapet

Detail 2.2.2

Conventional Curtain Wall System – Insulated Spandrel & Roof Intersection

Thermal Performance Indicators

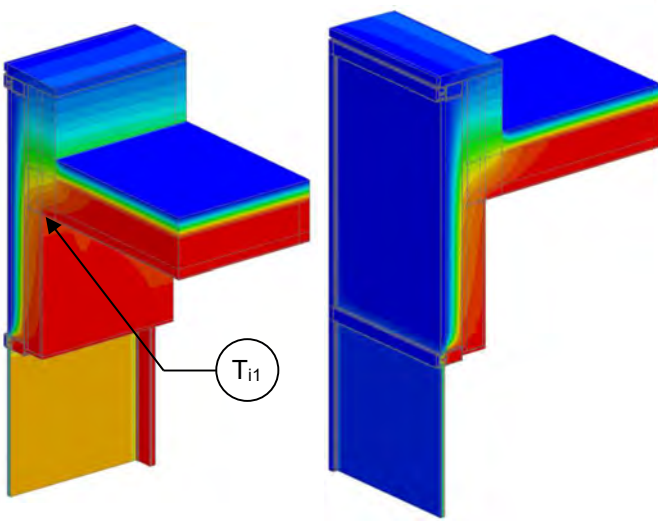

View from Interior²

View from Exterior²

Spandrel Wall 1D (Nominal) R-Value	R _{1D}	R-3.7 (0.65 RSI) + backpan insulation
Transmittance / Resistance without Anomaly	U _r , R _r , U _s , R _s , U _g	“clear wall” U- and R-value r = roof s = spandrel wall g = glazing
Transmittance / Resistance	U, R	U and R-values for the assembly
Surface Temperature Index ¹	T _i	0 = exterior temperature 1 = interior temperature
Linear Transmittance	ψ	Incremental increase in transmittance per linear length of parapet

¹Assumptions and limitations for surface temperatures identified in ASHRAE 1365-RP

²Thermal image shown is for the Aerogel detail

Nominal (1D) vs. Assembly Performance Indicators

Base Assembly – Roof

Roof Insulation 1D R-Value (RSI)	R _r ft ² ·hr·°F / Btu (m ² K / W)	U _r Btu/ft ² ·hr ·°F (W/m ² K)
R-20 (3.52)	R-21.9 (3.86)	0.046 (0.26)

Base Assembly – Glazing

U _{centre of glass} Btu/ft ² ·hr ·°F (W/m ² K)	U _g Btu/ft ² ·hr ·°F (W/m ² K)
0.321 (1.82)	0.429 (2.44)

Base Assembly – Spandrel Section

Backpan Insulation 1D R-Value (RSI)	R _{1D} ft ² ·hr·°F / Btu (m ² K / W)	R _s ft ² ·hr·°F / Btu (m ² K / W)	U _s Btu/ft ² ·hr ·°F (W/m ² K)
R-16.8 (2.96)	R-20.5 (3.61)	R-8.9 (1.56)	0.112 (0.64)

Parapet Linear Transmittance

Parapet Insulation	R ft ² ·hr·°F / Btu (m ² K / W)	U Btu/ft ² ·hr ·°F (W/m ² K)	ψ Btu/ft hr °F (W/m K)
Conventional	R-2.5 (0.44)	0.397 (2.25)	0.614 (1.06)
Aerogel	R-2.8 (0.49)	0.363 (2.06)	0.513 (0.89)

Temperature Indices

	Conventional	Aerogel	
T _{i1}	0.94	0.94	Min T on interior concrete, at roof intersection

Detail 2.2.3

Conventional Curtain Wall System with Insulated Spandrel Panel and 3 5/8" x 1 5/8" Steel Stud (16" o.c.) – Concrete Parapet Roof Intersection & Spray Foam Insulation in Stud Cavity

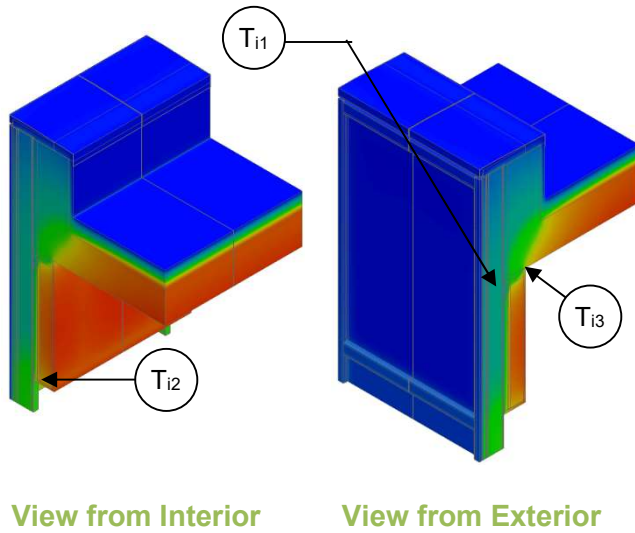

Thermal Performance Indicators

Assembly 1D (Nominal) R-Value	R_{1D}	R-14.9 (2.62 RSI) + backpan insulation
Transmittance / Resistance without Anomaly	U_r, R_r, U_s, R_s	"clear wall" U- and R-value r = insulated roof s = curtain wall spandrel
Surface Temperature Index ¹	T_i	0 = exterior temperature 1 = interior temperature
Linear Transmittance	ψ	Incremental increase in transmittance per linear length of parapet

¹Assumptions and limitations for surface temperatures identified in ASHRAE 1365-RP

Nominal (1D) vs. Assembly Performance Indicators

Base Assembly – Spandrel Panel Section

Backpan Insulation 1D R-Value (RSI)	R_{1D} ft ² ·hr·°F / Btu (m ² K / W)	R_s ft ² ·hr·°F / Btu (m ² K / W)	U_s Btu/ft ² ·hr ·°F (W/m ² K)
R-1 ² (0.18)	R-15.9 (2.80)	R-7.4 (1.30)	0.135 (0.77)
R-5 (0.88)	R-19.9 (3.50)	R-8.2 (1.44)	0.122 (0.69)
R-15 (2.64)	R-29.9 (5.26)	R-8.8 (1.55)	0.113 (0.64)
R-25 (4.40)	R-39.9 (7.02)	R-9.1 (1.60)	0.110 (0.63)

² This value represents no insulation in the back pan.

Base Assembly – Roof

Roof Insulation 1D R-Value (RSI)	R_r ft ² ·hr·°F / Btu (m ² K / W)	U_r Btu/ft ² ·hr ·°F (W/m ² K)
R-20 (3.52)	R-21.9 (3.86)	0.046 (0.26)

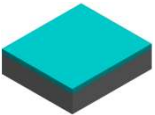

Parapet Linear Transmittance

Backpan Insulation 1D R-Value (RSI)	R ft ² ·hr·°F / Btu (m ² K / W)	U Btu/ft ² ·hr ·°F (W/m ² K)	ψ Btu/ft hr °F (W/m K)
R-1 (0.18)	R-6.6 (1.16)	0.151 (0.86)	0.426 (0.738)
R-5 (0.88)	R-7.0 (1.23)	0.143 (0.81)	0.404 (0.699)
R-15 (2.64)	R-7.4 (1.30)	0.136 (0.77)	0.384 (0.664)
R-25 (4.40)	R-7.5 (1.32)	0.134 (0.76)	0.380 (0.657)

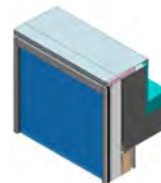

Temperature Indices

	R1	R5	R15	R25	
T_{i1}	0.26	0.34	0.38	0.39	Min T on Back Pan, at the mullion, the between slab and bottom transom
T_{i2}	0.47	0.51	0.53	0.53	Min T on interior frame, at mullion transom corner
T_{i3}	0.60	0.64	0.65	0.66	Min T ceiling, at gypsum/ceiling intersection, adjacent to curtain wall anchor

Detail 2.2.4

Conventional Curtain Wall System with Insulated Spandrel Panel & 3 5/8" x 1 5/8" Steel Stud (16" o.c.) – Insulated Concrete with Spandrel & Roof Intersection

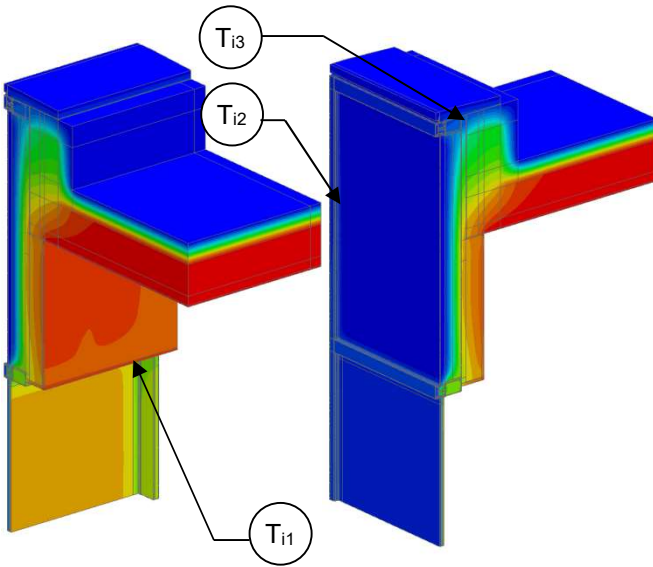

View from Interior

View from Exterior

Thermal Performance Indicators

Spandrel Wall 1D (Nominal) R-Value	R_{1D}	R-3.7 (0.65 RSI) + backpan insulation
Transmittance / Resistance without Anomaly	U_r, R_r, U_s, R_s, U_g	“clear field” U- and R-value r = roof s = spandrel wall g = glazing
Transmittance / Resistance	U, R	U- and R-values for overall assembly
Surface Temperature Index ¹	T_i	0 = exterior temperature 1 = interior temperature
Linear Transmittance	ψ	Incremental increase in transmittance per linear length of parapet

¹Assumptions and limitations for surface temperatures identified in ASHRAE 1365-RP

Nominal (1D) vs. Assembly Performance Indicators

Base Assembly – Roof

Roof Insulation 1D R-Value (RSI)	R_r ft ² ·hr·°F / Btu (m ² K / W)	U_r Btu/ft ² ·hr ·°F (W/m ² K)
R-20 (3.52)	R-21.9 (3.86)	0.046 (0.26)

Base Assembly - Glazing

$U_{\text{centre of glass}}$ Btu/ft ² ·hr ·°F (W/m ² K)	U_g Btu/ft ² ·hr ·°F (W/m ² K)
0.321 (1.82)	0.429 (2.44)

Base Assembly – Spandrel Section

Backpan Insulation 1D R-Value (RSI)	R_{1D} ft ² ·hr·°F / Btu (m ² K / W)	R_s ft ² ·hr·°F / Btu (m ² K / W)	U_s Btu/ft ² ·hr ·°F (W/m ² K)
R-8.4 (1.48)	R-12.1 (2.13)	R-6.9 (1.21)	0.145 (0.82)
R-16.8 (2.96)	R-20.5 (3.61)	R-8.8 (1.55)	0.113 (0.64)

Parapet Linear Transmittance

Spandrel Insulation 1D R-Value (RSI)	R ft ² ·hr·°F / Btu (m ² K / W)	U Btu/ft ² ·hr ·°F (W/m ² K)	ψ Btu/ft ·hr·°F (W/m K)
R-8.4 (1.48)	R-3.7 (0.64)	0.273 (1.55)	0.444 (0.768)
R-16.8 (2.96)	R-3.9 (0.69)	0.254 (1.44)	0.439 (0.760)

Temperature Indices

	R8.4	R16.8	
T_{11}	0.49	0.53	Min T on interior frame, along head at edge of glazing
T_{12}	0.57	0.64	Min T on concrete ceiling, at curtain wall anchor
T_{13}	0.13	0.15	Min T on frame, at top of parapet

Detail 2.3.1

Conventional Curtain Wall System with Insulated Spandrel Panel– Un-insulated Jamb Intersection with Vision Section

Thermal Performance Indicators

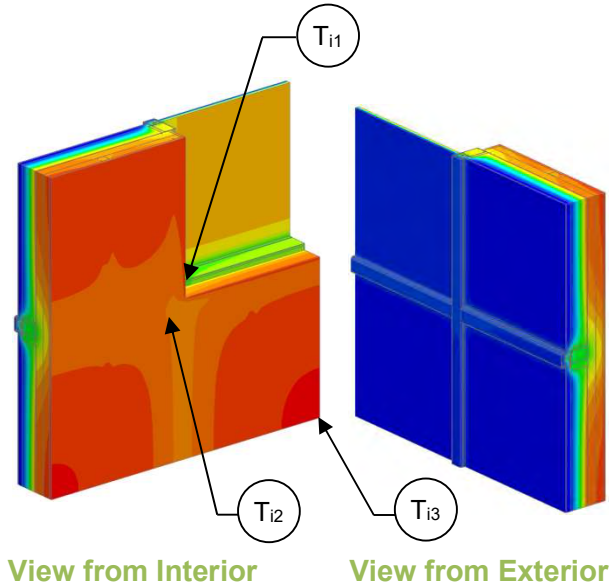

Assembly 1D (Nominal) R-Value	R_{1D}	R-3.7 (0.65 RSI) + backpan insulation
Transmittance / Resistance	U_w, R_w, U_g	U-value and R-value for w = spandrel wall g = glazing, including framing
Transmittance / Resistance	U, R	U- and R-values for overall assembly
Surface Temperature Index ¹	T_i	0 = exterior temperature 1 = interior temperature

¹Assumptions and limitations for surface temperatures identified in ASHRAE 1365-RP

Nominal (1D) vs. Assembly Performance Indicators

Spandrel Section

Backpan Insulation 1D R-Value (RSI)	R_{1D} ft ² ·hr·°F / Btu (m ² K / W)	R_w ft ² ·hr·°F / Btu (m ² K / W)	U_w Btu/ft ² ·hr·°F (W/m ² K)
R-8.4 (1.48)	R-12.1 (2.13)	R-4.5 (0.80)	0.221 (1.25)
R-16.8 (2.96)	R-20.5 (3.61)	R-5.3 (0.93)	0.189 (1.07)

Glazing

$U_{\text{centre of glass}}$ Btu/ft ² ·hr·°F (W/m ² K)	U_g Btu/ft ² ·hr·°F (W/m ² K)
0.321 (1.82)	0.429 (2.44)

Combined Assembly

Backpan Insulation 1D R-Value (RSI)	R ft ² ·hr·°F / Btu (m ² K / W)	U Btu/ft ² ·hr·°F (W/m ² K)
R-8.4 (1.48)	R-3.7 (0.65)	0.273 (1.55)
R-16.8 (2.96)	R-4.0 (0.71)	0.249 (1.41)

Temperature Indices

	R8.4	R16.8	
T_{i1}	0.46	0.52	Min T on frame, at corner of lower glazing
T_{i2}	0.47	0.58	Min T on backpan, at upper corner diagonal from glazing
T_{i3}	0.81	0.88	Max T on backpan, at centre of backpan below glazing

Detail 2.3.2

Conventional Curtain Wall System with Insulated Spandrel Panel–Rigid Insulated Jamb Intersection with Vision Section

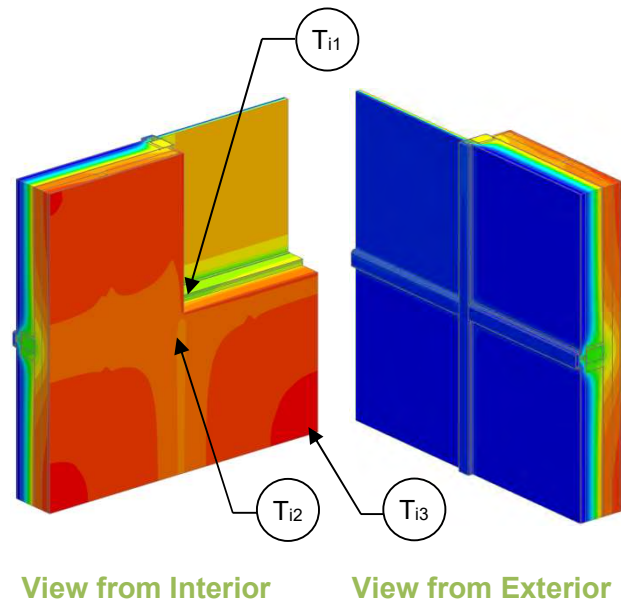

Thermal Performance Indicators

Assembly 1D (Nominal) R-Value	R_{1D}	R-3.7 (0.65 RSI) + backpan insulation
Transmittance / Resistance	U_w, R_w, U_g	U-value and R-value for w = spandrel wall g = glazing, including framing
Transmittance / Resistance	U, R	U- and R-values for overall assembly
Surface Temperature Index ¹	T_i	0 = exterior temperature 1 = interior temperature

¹Assumptions and limitations for surface temperatures identified in ASHRAE 1365-RP

Nominal (1D) vs. Assembly Performance Indicators

Spandrel Section

Backpan Insulation 1D R-Value (RSI)	R_{1D} ft ² ·hr·°F / Btu (m ² K / W)	R_w ft ² ·hr·°F / Btu (m ² K / W)	U_w Btu/ft ² ·hr·°F (W/m ² K)
R-8.4 (1.48)	R-12.1 (2.13)	R-4.8 (0.84)	0.209 (1.19)
R-16.8 (2.96)	R-20.5 (3.61)	R-6.2 (1.09)	0.161 (0.92)

Glazing

$U_{\text{centre of glass}}$ Btu/ft ² ·hr·°F (W/m ² K)	U_g Btu/ft ² ·hr·°F (W/m ² K)
0.321 (1.82)	0.429 (2.44)

Combined Assembly

Backpan Insulation 1D R-Value (RSI)	R ft ² ·hr·°F / Btu (m ² K / W)	U Btu/ft ² ·hr·°F (W/m ² K)
R-8.4 (1.48)	R-3.8 (0.67)	0.264 (1.50)
R-16.8 (2.96)	R-4.4 (0.77)	0.228 (1.30)

Temperature Indices

	R8.4	R16.8	
T_{i1}	0.47	0.54	Min T on frame, at corner of lower glazing
T_{i2}	0.50	0.62	Min T on backpan, at upper corner diagonal from glazing
T_{i3}	0.81	0.88	Max T on backpan, at centre of backpan below glazing

Detail 2.3.3

Conventional Curtain Wall System with Insulated Spandrel Panel – Aerogel Insulated Jamb Intersection with Vision Section

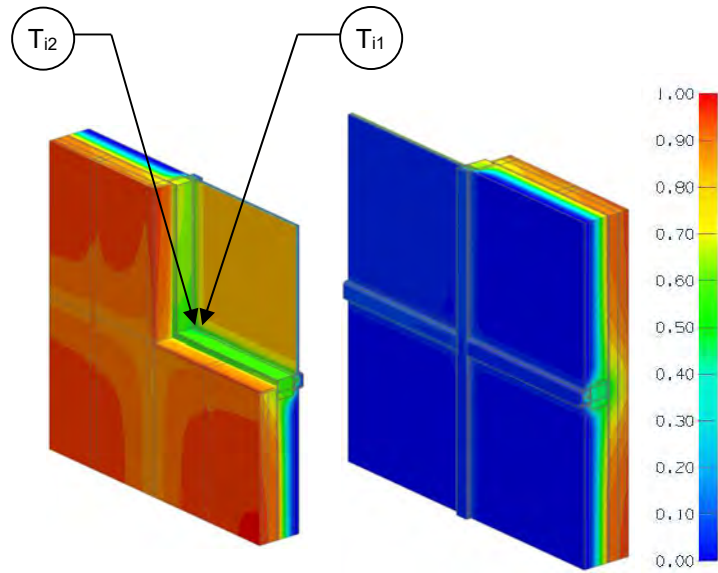

Thermal Performance Indicators

Assembly 1D (Nominal) R-Value	R_{1D}	R-3.7 (0.65 RSI) + R-16.8 (2.96 RSI) backpan insulation
Transmittance / Resistance	U_w, R_w, U_g	U-value and R-value for w = spandrel wall g = glazing, including framing
Transmittance / Resistance	U, R	U and R-values for the assembly
Surface Temperature Index ¹	T_i	0 = exterior temperature 1 = interior temperature

¹Assumptions and limitations for surface temperatures identified in ASHRAE 1365-RP

²Thermal image shown is for the Aerogel detail

View from Interior²

View from Exterior²

Scenario

Scenario	Jamb Condition
A	No Aerogel
B	Aerogel

Nominal (1D) vs. Assembly Performance Indicators

Spandrel Section

Scenario	R_{1D} ft ² ·hr·°F / Btu (m ² K / W)	R_w ft ² ·hr·°F / Btu (m ² K / W)	U_w Btu/ft ² ·hr·°F (W/m ² K)
A	R-20.5 (3.61)	R-5.3 (0.93)	0.189 (1.07)
B	R-20.5 (3.61)	R-6.5 (1.14)	0.155 (0.88)

Glazing

$U_{\text{centre of glass}}$ Btu/ft ² ·hr·°F (W/m ² K)	U_g Btu/ft ² ·hr·°F (W/m ² K)
0.321 (1.82)	0.429 (2.44)

Combined Assembly

Scenario	R ft ² ·hr·°F / Btu (m ² K / W)	U Btu/ft ² ·hr·°F (W/m ² K)
Scenario A	R-4.0 (0.71)	0.249 (1.41)
A	R-4.5 (0.79)	0.224 (1.27)

Temperature Indices

	A	B	
T_{i1}	0.47	0.51	Min T on glazing, at corner of glass
T_{i2}	0.53	0.59	Min T on frame, at corner of glass

Detail 2.4.1

Conventional Curtain Wall with Insulated Spandrel Panel & 3 5/8" x 1 5/8" Steel Stud (16" o.c.) - Beam Intersection Connected to Concrete Slab

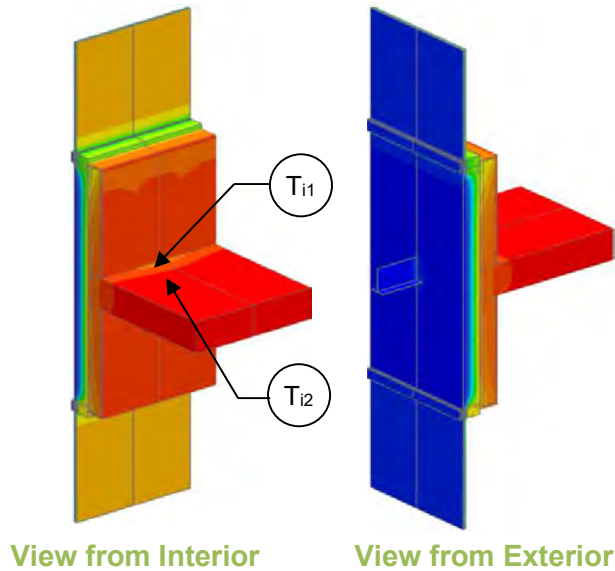

Thermal Performance Indicators

Assembly 1D (Nominal) R-Value	R_{1D}	R-3.2 (0.57 RSI) + backpan insulation
Transmittance / Resistance without Anomaly	U_o, R_o	"clear wall" U- and R-value of spandrel without slab and beam
Transmittance / Resistance	U, R	U and R-values for the assembly including spandrel, slab and beam intersection
Surface Temperature Index ¹	T_i	0 = exterior temperature 1 = interior temperature
Point Transmittance	χ	Incremental increase in transmittance for steel beam attached to slab

¹Assumptions and limitations for surface temperatures identified in ASHRAE 1365-RP

Nominal (1D) vs. Assembly Performance Indicators

Backpan insulation 1D R-Value (RSI)	R_{1D} ft ² ·hr·°F / Btu (m ² K / W)	R_o ft ² ·hr·°F / Btu (m ² K / W)	U_o Btu/ft ² ·hr ·°F (W/m ² K)	R ft ² ·hr·°F / Btu (m ² K / W)	U Btu/ft ² ·hr ·°F (W/m ² K)	χ Btu/hr · °F (W/K)
R-8.4 (1.48)	R-11.6 (2.05)	R-6.5 (1.15)	0.153 (0.87)	R-5.6 (0.99)	0.177 (1.01)	0.182 (0.10)
R-16.8 (2.96)	R-20.0 (3.53)	R-8.1 (1.42)	0.124 (0.70)	R-6.6 (1.15)	0.153 (0.87)	0.220 (0.12)

Temperature Indices

	R8.4	R16.8	
T_{i1}	0.46	0.48	Min T on knife edge and backpan, at intersection
T_{i2}	0.69	0.68	Min T on slab, below knife edge intersection

Detail 2.4.2

Conventional Curtain Wall with Insulated Spandrel Panel & 5 5/8" x 1 5/8" Steel Stud (16" o.c.)- Beam Intersection Connected to Steel Beam

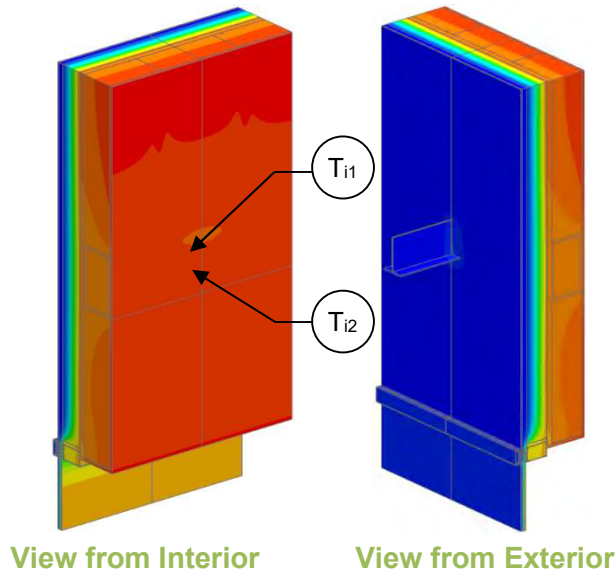

Thermal Performance Indicators

Assembly 1D (Nominal) R-Value	R_{1D}	R-3.2 (0.57 RSI) + ackpan insulation
Transmittance / Resistance without Anomaly	U_o, R_o	"clear wall" U- and R-value of spandrel without beam
Transmittance / Resistance	U, R	U and R-values for the assembly including spandrel and beam intersection
Surface Temperature Index ¹	T_i	0 = exterior temperature 1 = interior temperature
Point Transmittance	χ	Incremental increase in transmittance for steel beam attached to a steel beam

¹Assumptions and limitations for surface temperatures identified in ASHRAE 1365-RP

Nominal (1D) vs. Assembly Performance Indicators

Backpan Insulation 1D R-Value (RSI)	R_{1D} ft ² ·hr·°F / Btu (m ² K / W)	R_o ft ² ·hr·°F / Btu (m ² K / W)	U_o Btu/ft ² ·hr·°F (W/m ² K)	R ft ² ·hr·°F / Btu (m ² K / W)	U Btu/ft ² ·hr·°F (W/m ² K)	χ Btu/hr·°F (W/K)
R-8.4 (1.48)	R-11.6 (2.05)	R-9.5 (1.67)	0.105 (0.60)	R-7.1 (1.25)	0.141 (0.80)	0.268 (0.14)
R-16.8 (2.96)	R-20.0 (3.53)	R-13.5 (2.38)	0.074 (0.42)	R-8.8 (1.55)	0.114 (0.65)	0.296 (0.16)

Temperature Indices

	R8.4	R16.8	
T_{i1}	0.49	0.52	Min T on knife edge and backpan, at intersection
T_{i2}	0.66	0.69	Min T on steel beam, below knife edge intersection

Detail 2.4.3

Conventional Curtain Wall with Insulated Spandrel Panel & 3 5/8" x 1 5/8" Steel Stud (16" o.c.) - Canopy Beam & Gutter Intersection

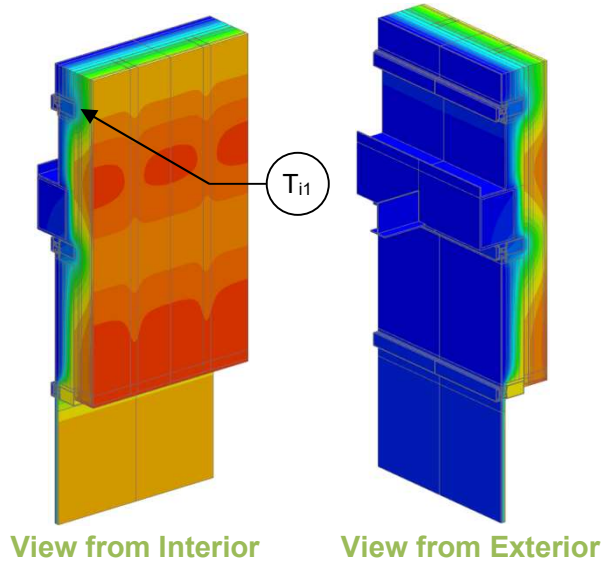

Thermal Performance Indicators

Assembly 1D (Nominal) R-Value	R_{1D}	R-3.2 (0.57 RSI) + backpan insulation
Transmittance / Resistance without Anomaly	U_o, R_o	"clear wall" U- and R-value of spandrel without beam
Transmittance / Resistance	U, R	U and R-values for the assembly including spandrel and beam intersection
Surface Temperature Index ¹	T_i	0 = exterior temperature 1 = interior temperature
Linear Transmittance	ψ	Incremental increase in transmittance per linear length of gutter

¹Assumptions and limitations for surface temperatures identified in ASHRAE 1365-RP

Nominal (1D) vs. Assembly Performance Indicators

Backpan Insulation 1D R-Value (RSI)	R_{1D} ft ² ·hr·°F / Btu (m ² K / W)	R_o ft ² ·hr·°F / Btu (m ² K / W)	U_o Btu/ft ² ·hr ·°F (W/m ² K)	R ft ² ·hr·°F / Btu (m ² K / W)	U Btu/ft ² ·hr ·°F (W/m ² K)	ψ Btu/ft ·hr·°F (W/m K)
R-8.4 (1.48)	R-11.6 (2.05)	R-9.4 (1.66)	0.106 (0.60)	R-4.5 (0.80)	0.221 (1.25)	0.588 (1.017)
R-16.8 (2.96)	R-20.0 (3.53)	R-13.5 (2.38)	0.074 (0.42)	R-4.8 (0.84)	0.210 (1.19)	0.695 (1.204)

Temperature Indices

	R8.4	R16.8	
T_{i1}	0.15	0.16	Min T on upper backpan, away from knife edge

Detail 2.4.4

Conventional Curtain Wall with Insulated Spandrel Panel & 5 5/8" x 1 5/8" Steel Stud (16" o.c.) - Beam Intersection Connected to Steel Beam with Additional Mullions

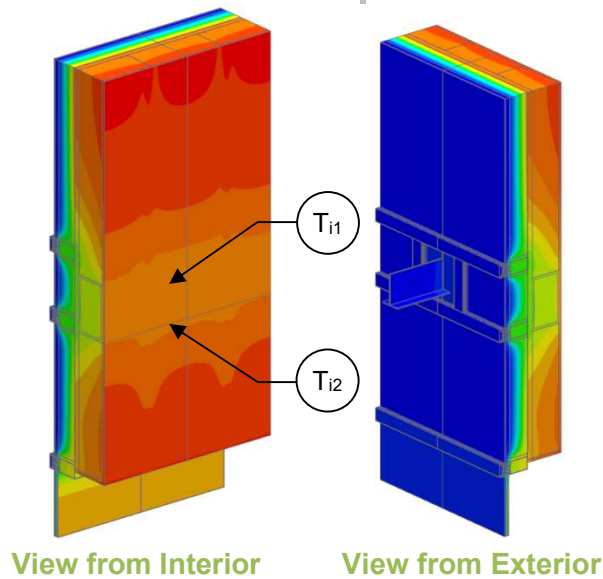

Thermal Performance Indicators

Assembly 1D (Nominal) R-Value	R_{1D}	R-3.2 (0.57 RSI) + backpan insulation
Transmittance / Resistance without Anomaly	U_o, R_o	"clear wall" U- and R-value of spandrel without beam
Transmittance / Resistance	U, R	U and R-values for the assembly including spandrel and beam intersection
Surface Temperature Index ¹	T_i	0 = exterior temperature 1 = interior temperature
Point Transmittance	χ	Incremental increase in transmittance for a steel beam attached to a steel beam with additional mullions

¹Assumptions and limitations for surface temperatures identified in ASHRAE 1365-RP

Nominal (1D) vs. Assembly Performance Indicators

Backpan Insulation 1D R-Value (RSI)	R_{1D} ft ² ·hr·°F / Btu (m ² K / W)	R_o ft ² ·hr·°F / Btu (m ² K / W)	U_o Btu/ft ² ·hr·°F (W/m ² K)	R ft ² ·hr·°F / Btu (m ² K / W)	U Btu/ft ² ·hr·°F (W/m ² K)	χ Btu/hr·°F (W/K)
R-8.4 (1.48)	R-11.6 (2.05)	R-5.8 (1.02)	0.172 (0.98)	R-5.3 (0.93)	0.19 (1.08)	0.148 (0.08)
R-16.8 (2.96)	R-20.0 (3.53)	R-7.4 (1.30)	0.135 (0.77)	R-6.3 (1.10)	0.16 (0.91)	0.208 (0.11)

Temperature Indices

	R8.4	R16.8	
T_{i1}	0.42	0.45	Min T on knife edge and backpan, at intersection
T_{i2}	0.53	0.57	Min T on steel beam, underneath the knife edge

Detail 2.5.1

Conventional Curtain Wall System – At-Grade Slab Transition

Thermal Performance Indicators

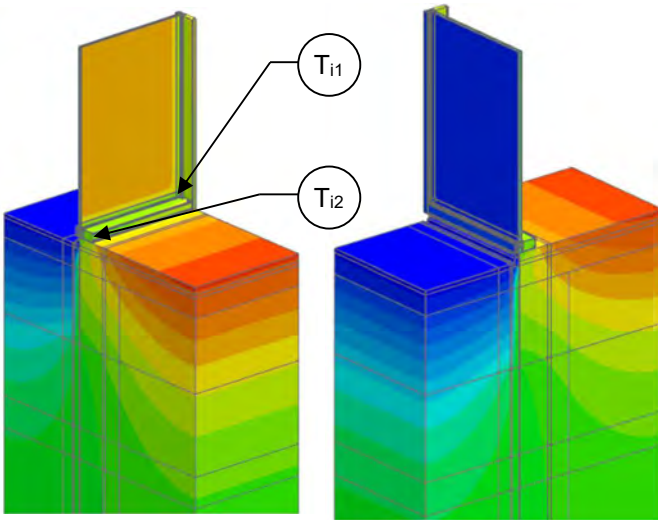

View from Interior²

View from Exterior²

Transmittance / Resistance without Anomaly	U_f , R_f , U_g	“clear field” U- and R-value: f = foundation g = glazing, including framing
Transmittance / Resistance	U, R	U and R-values for the assembly
Surface Temperature Index ¹	T_i	0 = exterior temperature 1 = interior temperature
Linear Transmittance	ψ	Incremental increase in transmittance per linear length of slab-on-grade

¹Assumptions and limitations for surface temperatures identified in ASHRAE 1365-RP

²Thermal image shown is for the Aerogel detail

³R-value and U-value do not include the soil.

Nominal (1D) vs. Assembly Performance Indicators

Base Assembly – Foundation³

R_f ft ² ·hr·°F / Btu (m ² K / W)	U_f Btu/ft ² ·hr ·°F (W/m ² K)
R-1.3 (0.24)	0.746 (4.24)

Base Assembly - Glazing

$U_{\text{centre of glass}}$ Btu/ft ² ·hr ·°F (W/m ² K)	U_g Btu/ft ² ·hr ·°F (W/m ² K)
0.321 (1.82)	0.429 (2.44)

Foundation Linear Transmittance

Slab Edge Insulation	R ft ² ·hr·°F / Btu (m ² K / W)	U Btu/ft ² ·hr ·°F (W/m ² K)	ψ Btu/ft hr °F (W/m K)
Conventional	R-3.9 (0.68)	0.259 (1.47)	0.495 (0.857)
Aerogel	R-4.1 (0.72)	0.244 (1.39)	0.370 (0.640)

Temperature Indices

	Conventional	Aerogel	
T_{i1}	0.54	0.50	Min T on glazing, at corner of glass
T_{i2}	0.70	0.62	Min T on concrete, at curtain wall sill intersection

3.0 Unitized Curtain Wall

Detail 3.1.1	B.3.1
Unitized Curtain Wall System – Spandrel Clear Wall & No Interior Stud Cavity Insulation	
Detail 3.1.2	B.3.2
Unitized Curtain Wall System – Spandrel Clear Wall & Interior Sprayfoam Insulation	
Detail 3.2.1	B.3.3
Unitized Curtain Wall System – Intermediate Floor Intersection & No Interior Stud Cavity Insulation	
Detail 3.2.2	B.3.4
Unitized Curtain Wall System – Intermediate Floor Intersection & Interior Sprayfoam Insulation	
Detail 3.2.3	B.3.5
Unitized Curtain Wall System with 4-Sided Structural Silicone Joints and 5' x 5' Spandrel Section – Insulated Backpan and Intermediate Floor Intersection	
Detail 3.2.4	B.3.6
Unitized Curtain Wall System with 4-Sided Structural Silicone Joints and 5' x 5' Spandrel Section – AIM Applications and Intermediate Floor Intersection	
Detail 3.2.5	B.3.7
Unitized Curtain Wall System with 4-Sided Structural Silicone Joints and 5' x 5' Spandrel Section – Insulated Backpan and Improved Glazing at Intermediate Floor Intersection	
Detail 3.2.6	B.3.8
Unitized Curtain Wall System with 4-Sided Structural Silicone Joints and 5' x 5' Spandrel Section – AIM Applications and Improved Glazing at Intermediate Floor Intersection	
Detail 3.3.1	B.3.9
Unitized Curtain Wall System – Window Wall Transition	
Detail 3.3.2	B.3.10
Unitized Curtain Wall System – Window Wall Transition with Foam Insulation	

Detail 3.1.1

Unitized Curtain Wall System – Spandrel Clear Wall & No Interior Stud Cavity Insulation

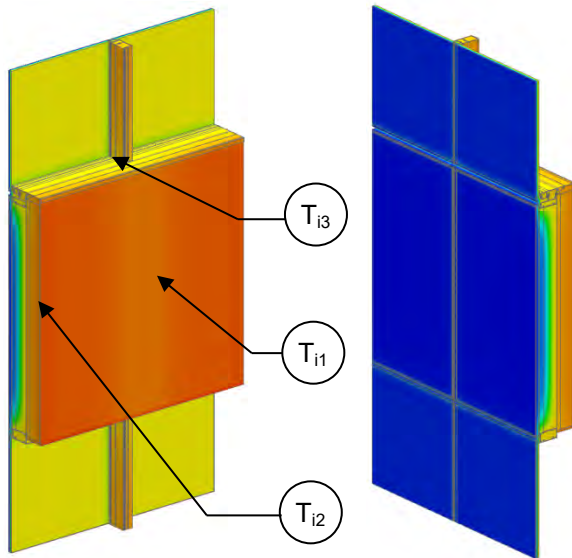

View from Interior View from Exterior

Thermal Performance Indicators

Assembly 1D (Nominal) R-Value	R_{1D}	R-3.7 (0.65 RSI) + backpan insulation
Transmittance / Resistance	U_w, R_w, U_g	U-value and R-value for w = spandrel wall g = glazing, including framing
Transmittance / Resistance	U, R	U- and R-values for overall assembly
Surface Temperature Index ¹	T_i	0 = exterior temperature 1 = interior temperature

¹Assumptions and limitations for surface temperatures identified in ASHRAE 1365-RP

Nominal (1D) vs. Assembly Performance Indicators

Spandrel Section

Backpan Insulation 1D R-Value (RSI)	R_{1D} ft ² ·hr·°F / Btu (m ² K / W)	R_w ft ² ·hr·°F / Btu (m ² K / W)	U_w Btu/ft ² ·hr·°F (W/m ² K)
R-8.4 (1.48)	R-12.1 (2.13)	R-6.4 (1.12)	0.157 (0.89)
R-16.8 (2.96)	R-20.5 (3.61)	R-7.7 (1.36)	0.129 (0.74)

Glazing

$U_{\text{centre of glass}}$ Btu/ft ² ·hr·°F (W/m ² K)	U_g Btu/ft ² ·hr·°F (W/m ² K)
0.321 (1.82)	0.373 (2.12)

Combined Assembly

Backpan Insulation 1D R-Value (RSI)	R ft ² ·hr·°F / Btu (m ² K / W)	U Btu/ft ² ·hr·°F (W/m ² K)
R-8.4 (1.48)	R-3.8 (0.66)	0.266 (1.51)
R-16.8 (2.96)	R-3.9 (0.69)	0.254 (1.44)

Temperature Indices

	R8.4	R16.8	
T_{i1}	0.66	0.70	Min T in stud cavity, at edge of backpan
T_{i2}	0.82	0.85	Max T on backpan, at centre of backpan
T_{i3}	0.61	0.62	Min T on frame, at corner of glazing

Detail 3.1.2

Unitized Curtain Wall System – Spandrel Clear Wall & Interior Sprayfoam Insulation

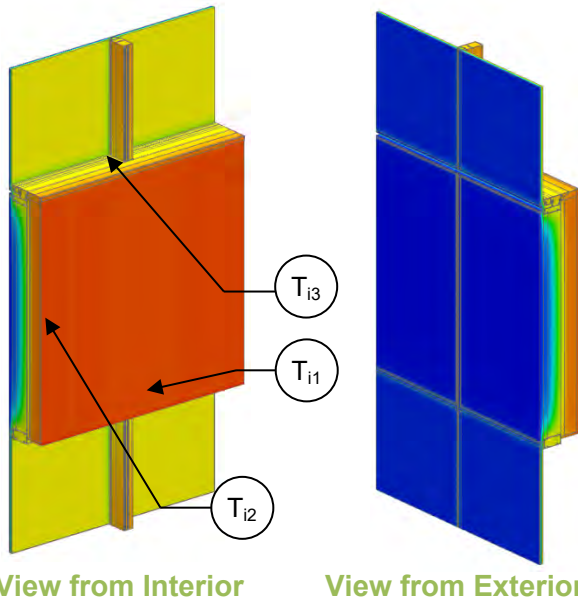

Thermal Performance Indicators

Assembly 1D (Nominal) R-Value	R_{1D}	R-15.7 (2.77 RSI) + backpan insulation
Transmittance / Resistance	U_w, R_w, U_g	U-value and R-value for w = spandrel wall g = glazing, including framing
Transmittance / Resistance	U, R	U- and R-values for overall assembly
Surface Temperature Index ¹	T_i	0 = exterior temperature 1 = interior temperature

¹Assumptions and limitations for surface temperatures identified in ASHRAE 1365-RP

Nominal (1D) vs. Assembly Performance Indicators

Spandrel Section

Backpan Insulation 1D R-Value (RSI)	R_{1D} ft ² ·hr·°F / Btu (m ² K / W)	R_w ft ² ·hr·°F / Btu (m ² K / W)	U_w Btu/ft ² ·hr ·°F (W/m ² K)
R-8.4 (1.48)	R-24.1 (4.24)	R-7.6 (1.33)	0.132 (0.75)
R-16.8 (2.96)	R-32.5 (5.72)	R-8.9 (1.57)	0.112 (0.64)

Glazing

$U_{\text{centre of glass}}$ Btu/ft ² ·hr ·°F (W/m ² K)	U_g Btu/ft ² ·hr ·°F (W/m ² K)
0.321 (1.82)	0.371 (2.11)

Combined Assembly

Backpan Insulation 1D R-Value (RSI)	R ft ² ·hr·°F / Btu (m ² K / W)	U Btu/ft ² ·hr ·°F (W/m ² K)
R-8.4 (1.48)	R-4.0 (0.70)	0.253 (1.44)
R-16.8 (2.96)	R-4.1 (0.72)	0.244 (1.39)

Temperature Indices

	R8.4	R16.8	
T_{i1}	0.83	0.84	Min T on sprayfoam, at bottom of spandrel
T_{i2}	0.89	0.90	Max T on sprayfoam, away from frame and studs
T_{i3}	0.60	0.61	Min T on frame, at corner of glazing

Detail 3.2.1

Unitized Curtain Wall System – Intermediate Floor Intersection & No Interior Stud Cavity Insulation

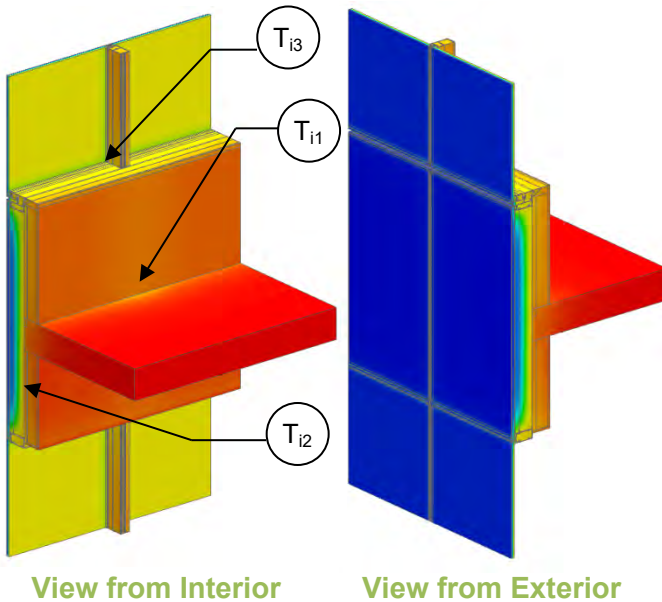

Thermal Performance Indicators

Assembly 1D (Nominal) R-Value	R_{1D}	R-3.7 (0.65 RSI) + backpan insulation
Transmittance / Resistance without Anomaly	U_w, R_w, U_g	“clear wall” U- and R-value, w = spandrel wall without slab g = glazing
Transmittance / Resistance	U_s, R_s, U_t, R_t	U and R-values for s = spandrel with slab t = combined glazing and spandrel with slab
Surface Temperature Index ¹	T_i	0 = exterior temperature 1 = interior temperature
Linear Transmittance	ψ	Incremental increase in transmittance per linear length of slab

¹Assumptions and limitations for surface temperatures identified in ASHRAE 1365-RP

²Spandrel section includes interface with slab and vision glazing

Nominal (1D) vs. Assembly Performance Indicators

Base Assembly - Spandrel Section Only

Backpan Insulation 1D R-Value (RSI)	R_{1D} ft ² ·hr·°F / Btu (m ² K / W)	R_w ft ² ·hr·°F / Btu (m ² K / W)	U_w Btu/ft ² ·hr ·°F (W/m ² K)
R-8.4 (1.48)	R-12.1 (2.13)	R-6.4 (1.12)	0.157 (0.89)
R-16.8 (2.96)	R-20.5 (3.61)	R-7.7 (1.36)	0.129 (0.74)

Base Assembly - Glazing

$U_{\text{centre of glass}}$ Btu/ft ² ·hr ·°F (W/m ² K)	U_g Btu/ft ² ·hr ·°F (W/m ² K)
0.321 (1.82)	0.373 (2.12)

Slab Linear Transmittance

Backpan Insulation 1D R-Value (RSI)	R_t ft ² ·hr·°F / Btu (m ² K / W)	U_t Btu/ft ² ·hr ·°F (W/m ² K)	ψ Btu/ft ·hr ·°F (W/m K)
R-8.4 (1.48)	R-3.7 (0.66)	0.267 (1.52)	0.004 (0.007)
R-16.8 (2.96)	R-3.9 (0.69)	0.254 (1.44)	0.002 (0.004)

Spandrel Section with Slab²

R_s ft ² ·hr·°F / Btu (m ² K / W)	U_s Btu/ft ² ·hr ·°F (W/m ² K)
R-6.3 (1.12)	0.158 (0.90)
R-7.7 (1.35)	0.130 (0.74)

Temperature Indices

	R8.4	R16.8	
T_{i1}	0.65	0.69	Min T in stud cavity, at anchor
T_{i2}	0.85	0.89	Max T on backpan, at centre of backpan under slab
T_{i3}	0.61	0.62	Min T on frame, at corner of glazing

Detail 3.2.2

Unitized Curtain Wall System – Intermediate Floor Intersection & Interior Sprayfoam Insulation

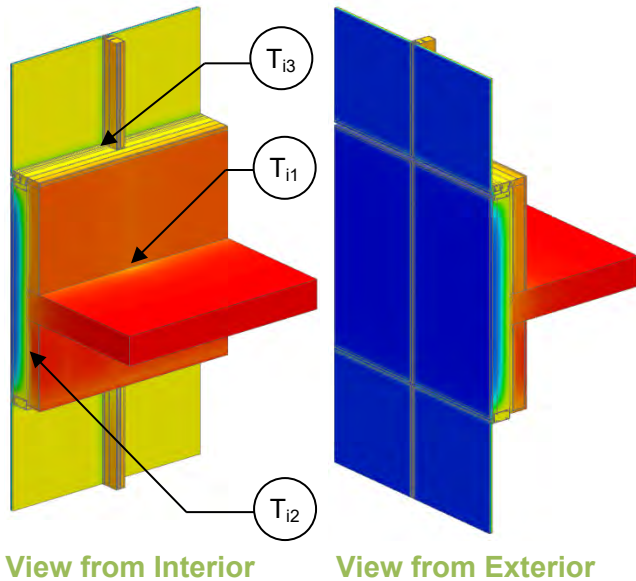

Thermal Performance Indicators

Assembly 1D (Nominal) R-Value	R_{1D}	R-15.7 (2.77 RSI) + backpan insulation
Transmittance / Resistance without Anomaly	U_w, R_w, U_g	“clear wall” U- and R-value, w = spandrel wall without slab g = glazing
Transmittance / Resistance	U_s, R_s, U_t, R_t	U and R-values for s = spandrel with slab t = combined glazing and spandrel with slab
Surface Temperature Index ¹	T_i	0 = exterior temperature 1 = interior temperature
Linear Transmittance	ψ	Incremental increase in transmittance per linear length of slab

¹Assumptions and limitations for surface temperatures identified in ASHRAE 1365-RP

²Spandrel section includes interface with slab and vision glazing

Nominal (1D) vs. Assembly Performance Indicators

Base Assembly - Spandrel Section Only

Backpan Insulation 1D R-Value (RSI)	R_{1D} ft ² ·hr·°F / Btu (m ² K / W)	R_w ft ² ·hr·°F / Btu (m ² K / W)	U_w Btu/ft ² ·hr ·°F (W/m ² K)
R-8.4 (1.48)	R-24.1 (4.24)	R-7.6 (1.33)	0.132 (0.75)
R-16.8 (2.96)	R-32.5 (5.72)	R-8.9 (1.57)	0.112 (0.64)

Base Assembly - Glazing

$U_{\text{centre of glass}}$ Btu/ft ² ·hr ·°F (W/m ² K)	U_g Btu/ft ² ·hr ·°F (W/m ² K)
0.321 (1.82)	0.371 (2.11)

Slab Linear Transmittance

Backpan Insulation 1D R-Value (RSI)	R_t ft ² ·hr·°F / Btu (m ² K / W)	U_t Btu/ft ² ·hr ·°F (W/m ² K)	ψ Btu/ft ·hr ·°F (W/m K)
R-8.4 (1.48)	R-3.9 (0.69)	0.256 (1.45)	0.031 (0.053)
R-16.8 (2.96)	R-4.1 (0.71)	0.246 (1.40)	0.022 (0.038)

Spandrel Section with Slab²

R_s ft ² ·hr·°F / Btu (m ² K / W)	U_s Btu/ft ² ·hr ·°F (W/m ² K)
R-7.2 (1.27)	0.138 (0.79)
R-8.6 (1.51)	0.117 (0.66)

Temperature Indices

	R8.4	R16.8	
T_{i1}	0.74	0.77	Min T on sprayfoam, at anchor
T_{i2}	0.94	0.95	Max T on sprayfoam, away from frame and studs below slab
T_{i3}	0.60	0.61	Min T on frame, at corner of glazing

Detail 3.2.3

Unitized Curtain Wall System with 4-Sided Structural Silicone Joints and 5' x 5' Spandrel Section – Insulated Backpan and Intermediate Floor Intersection

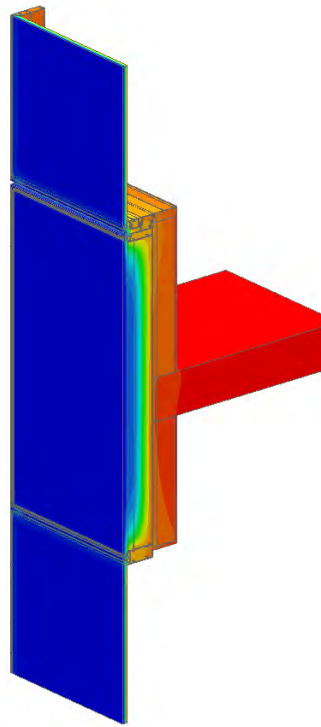

Thermal Performance Indicators



Transmittance / Resistance	U_s, R_s	Spandrel Section U-value and "Effective" R-value (including slab)
	U_g, R_g	Glazing U-value and "Effective" R-value
	U_t, R_t	Total Assembly U-value and "Effective" R-value

¹ U_t based on a window to wall ratio of 50%, but U_s is valid for all spandrel dimensions.

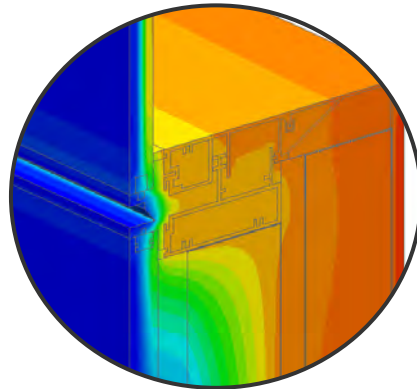

Mullion Detail

View from Exterior

Scenarios

Scenario	Vision Glass and Spacer	Insulation Thickness and Application
A	Double Glazed with Aluminum Spacer	4" (100 mm) Mineral Wool in Backpan
B	Double Glazed with Silicone Warm Edge Spacer	4" (100 mm) Mineral Wool in Backpan

Nominal (1D) vs. Assembly Performance Indicators

Scenario	Insulation R-Value (RSI)	U_s Btu/ft ² · hr · °F (W/m ² K)	R_s ft ² · hr · °F / Btu (m ² K / W)	U_g Btu/ft ² · hr · °F (W/m ² K)	R_g ft ² · hr · °F / Btu (m ² K / W)	U_t^1 Btu/ft ² · hr · °F (W/m ² K)	R_t ft ² · hr · °F / Btu (m ² K / W)
A	R-16.8 (2.96)	0.233 (1.32)	R-4.3 (0.76)	0.370 (2.10)	R-2.7 (0.48)	0.302 (1.72)	R-3.3 (0.58)
B	R-16.8 (2.96)	0.233 (1.32)	R-4.3 (0.76)	0.356 (2.02)	R-2.8 (0.50)	0.295 (1.67)	R-3.4 (0.60)

Detail 3.2.4

Unitized Curtain Wall System with 4-Sided Structural Silicone Joints and 5' x 5' Spandrel Section – AIM Applications and Intermediate Floor Intersection

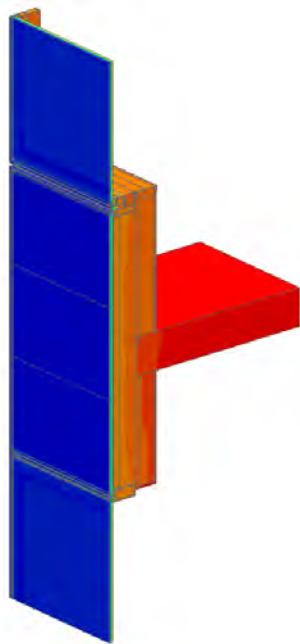

View from Exterior

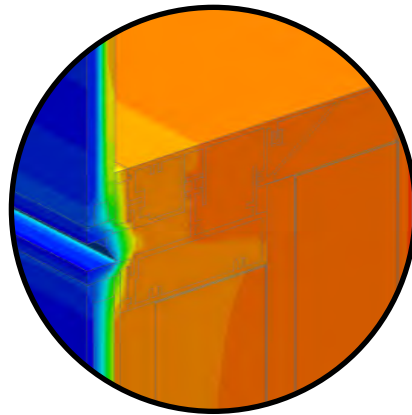

Mullion Detail

Thermal Performance Indicators

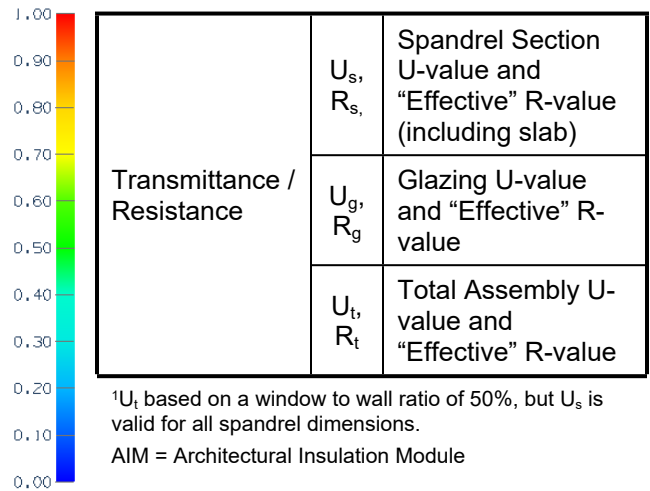

Scenarios

Scenario	Vision Glass and Spacer	Insulation Thickness and Application	AIM Spacer/Edge Condition
A	Double Glazed with Silicone Warm Edge Spacer	0.75" (19 mm) AIM between Glass	Silicone Warm Edge Spacer
B	Double Glazed with Silicone Warm Edge Spacer	0.75" (19 mm) AIM between Glass + 4" (100 mm) Mineral Wool in Backpan	Silicone Warm Edge Spacer
C	Double Glazed with Silicone Warm Edge Spacer	1" (25 mm) AIM between Metal Skins	Rigid Insulation

Nominal (1D) vs. Assembly Performance Indicators

Scenario	Insulation R-Value (RSI)	U_s Btu/ft ² · hr · °F (W/m ² K)	R_s ft ² · hr · °F / Btu (m ² K / W)	U_g Btu/ft ² · hr · °F (W/m ² K)	R_g ft ² · hr · °F / Btu (m ² K / W)	U_t ¹ Btu/ft ² · hr · °F (W/m ² K)	R_t ft ² · hr · °F / Btu (m ² K / W)
A	R-29.3 (5.16)	0.103 (0.59)	R-9.7 (1.71)	0.366 (2.08)	R-2.7 (0.48)	0.236 (1.34)	R-4.2 (0.75)
B	R-46.1 (8.12)	0.098 (0.56)	R-10.2 (1.79)	0.362 (2.06)	R-2.8 (0.49)	0.231 (1.31)	R-4.3 (0.76)
C	R-39.1 (6.89)	0.060 (0.34)	R-16.6 (2.92)	0.378 (2.15)	R-2.6 (0.47)	0.221 (1.25)	R-4.5 (0.80)

Detail 3.2.5

Unitized Curtain Wall System with 4-Sided Structural Silicone Joints and 5' x 5' Spandrel Section – Insulated Backpan and Improved Glazing at Intermediate Floor Intersection

Thermal Performance Indicators



Transmittance / Resistance	U_s, R_s	Spandrel Section U-value and “Effective” R-value (including slab)
	U_g, R_g	Glazing U-value and “Effective” R-value
	U_t, R_t	Total Assembly U-value and “Effective” R-value

¹ U_t based on a window to wall ratio of 50%, but U_s is valid for all spandrel dimensions.

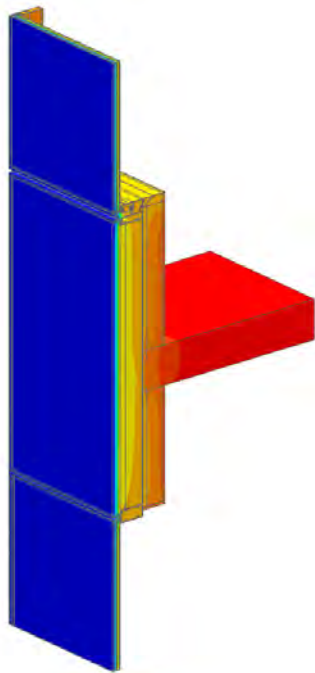

View from Exterior

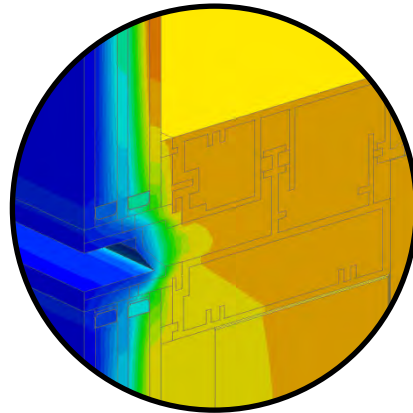

Mullion Detail

Scenario

Scenario	Vision Glass and Spacer	Insulation Thickness and Application
A	Triple Glazed with Aluminum Spacer	4" (100 mm) Mineral Wool in Backpan

Nominal (1D) vs. Assembly Performance Indicators

Scenario	Insulation R-Value (RSI)	U_s Btu/ft ² · hr · °F (W/m ² K)	R_s ft ² · hr · °F / Btu (m ² K / W)	U_g Btu/ft ² · hr · °F (W/m ² K)	R_g ft ² · hr · °F / Btu (m ² K / W)	U_t^1 Btu/ft ² · hr · °F (W/m ² K)	R_t ft ² · hr · °F / Btu (m ² K / W)
A	R-16.8 (2.96)	0.213 (1.21)	R-4.7 (0.83)	0.238 (1.35)	R-4.2 (0.74)	0.226 (1.28)	R-4.4 (0.78)

Detail 3.2.6

Unitized Curtain Wall System with 4-Sided Structural Silicone Joints and 5' x 5' Spandrel Section – AIM Applications and Improved Glazing at Intermediate Floor Intersection

Thermal Performance Indicators

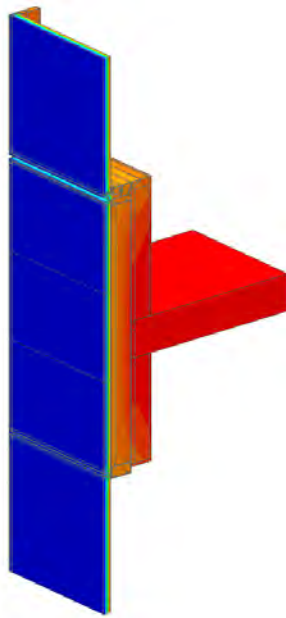

View from Exterior

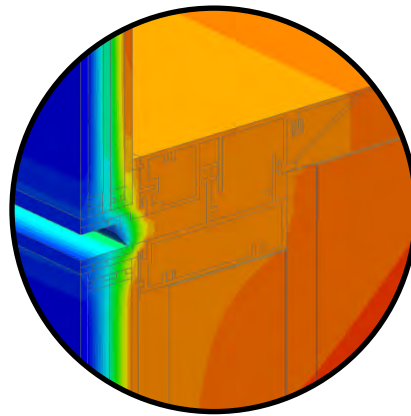

Mullion Detail



Transmittance / Resistance	U_s, R_s	Spandrel Section U-value and "Effective" R-value (including slab)
	U_g, R_g	Glazing U-value and "Effective" R-value
	U_t, R_t	Total Assembly U-value and "Effective" R-value

¹ U_t based on a window to wall ratio of 50%, but U_s is valid for all spandrel dimensions.

AIM = Architectural Insulation Module

Scenarios

Scenario	Vision Glass and Spacer	Insulation Thickness and Application	AIM Spacer/Edge Condition
A	Triple Glazed with Silicone Warm Edge Spacer	1.5" (38 mm) AIM between Glass + 4" (100 mm) Mineral Wool in Backpan	Silicone Warm Edge Spacer
B	Triple Glazed with Silicone Warm Edge Spacer	Shadow AIM with 5/8" (16mm) AIM between Glass + 4" (100 mm) Mineral Wool in Backpan	Silicone Warm Edge Spacer

Nominal (1D) vs. Assembly Performance Indicators

Scenario	Insulation R-Value (RSI)	U_s Btu/ft ² ·hr·°F (W/m ² K)	R_s ft ² ·hr·°F / Btu (m ² K / W)	U_g Btu/ft ² ·hr·°F (W/m ² K)	R_g ft ² ·hr·°F / Btu (m ² K / W)	U_t^1 Btu/ft ² ·hr·°F (W/m ² K)	R_t ft ² ·hr·°F / Btu (m ² K / W)
A	R-75.4 (13.28)	0.068 (0.39)	R-14.7 (2.59)	0.242 (1.37)	R-4.1 (0.73)	0.156 (0.88)	R-6.4 (1.13)
B	R-41.2 (7.26)	0.094 (0.53)	R-10.6 (1.87)	0.241 (1.37)	R-4.1 (0.73)	0.168 (0.96)	R-5.9 (1.05)

Detail 3.3.1

Unitized Curtain Wall System – Window Wall Transition

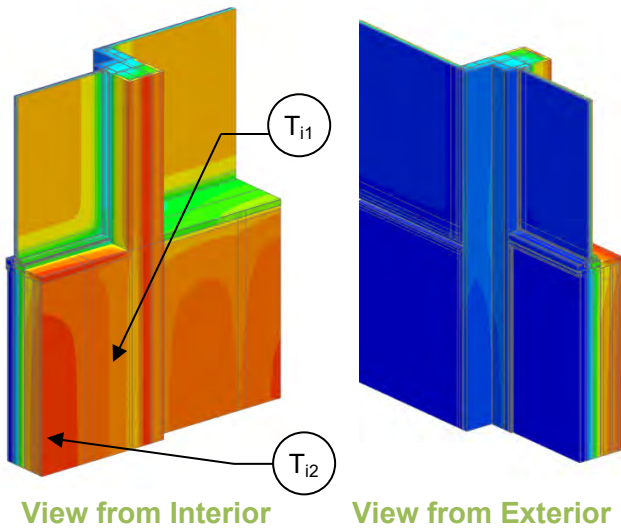

Thermal Performance Indicators

Assembly 1D (Nominal) R-Value	R_{1Dw}, R_{1Dcw}	Nominal thermal resistance of two base assemblies: w = window-wall R-3.7 (0.65 RSI) + backpan insulation cw= curtain-wall R-3.7 (0.65 RSI) + backpan insulation
Transmittance / Resistance without Anomaly	$U_w, R_w, U_{cw}, R_{cw}, U_g$	“clear wall” spandrel U- and R-value for the base assemblies g = glazing
Transmittance / Resistance	U, R	U and R-values for the assembly
Surface Temperature Index ¹	T_i	0 = exterior temperature 1 = interior temperature
Linear Transmittance	ψ	Incremental increase in transmittance per linear length of transition joint

¹Assumptions and limitations for surface temperatures identified in ASHRAE 1365-RP

Nominal (1D) vs. Assembly Performance Indicators

Base Assembly – Window Wall

Backpan Insulation 1D R-Value (RSI)	R_{1Dw} ft ² ·hr·°F / Btu (m ² K / W)	R_w ft ² ·hr·°F / Btu (m ² K / W)	U_w Btu/ft ² ·hr·°F (W/m ² K)
R-8.4 (1.48)	R-12.1 (2.13)	R-5.3 (0.94)	0.188 (1.07)
R-16.8 (2.96)	R-20.5 (3.61)	R-7.9 (1.39)	0.127 (0.72)

Base Assembly – Curtain Wall

Backpan Insulation 1D R-Value (RSI)	R_{1Dcw} ft ² ·hr·°F / Btu (m ² K / W)	R_{cw} ft ² ·hr·°F / Btu (m ² K / W)	U_{cw} Btu/ft ² ·hr·°F (W/m ² K)
R-8.4 (1.48)	R-12.1 (2.13)	R-5.0 (0.88)	0.200 (1.140)
R-16.8 (2.96)	R-20.5 (3.61)	R-7.2 (1.27)	0.139 (0.787)

Transition Joint Linear Transmittance

Backpan Insulation 1D R-Value (RSI)	R ft ² ·hr·°F / Btu (m ² K / W)	U Btu/ft ² ·hr·°F (W/m ² K)	ψ Btu/ft·hr·°F (W/m K)
R-8.4 (1.48)	R-2.7 (0.47)	0.327 (2.11)	0.120 (0.207)
R-16.8 (2.96)	R-2.9 (0.51)	0.347 (1.97)	0.125 (0.217)

Base Assembly – Glazing

$U_{\text{centre of glass}}$ Btu/ft ² ·hr·°F (W/m ² K)	U_g Btu/ft ² ·hr·°F (W/m ² K)
0.321 (1.82)	0.373 (2.12)

Temperature Indices

	R8.4	R16.8	
T_{i1}	0.61	0.69	Min T on backpan, along vertical mullion
T_{i2}	0.75	0.82	Max T on backpan, at centre of backpan

Detail 3.3.2

Unitized Curtain Wall System – Window Wall Transition with Foam Insulation

Thermal Performance Indicators

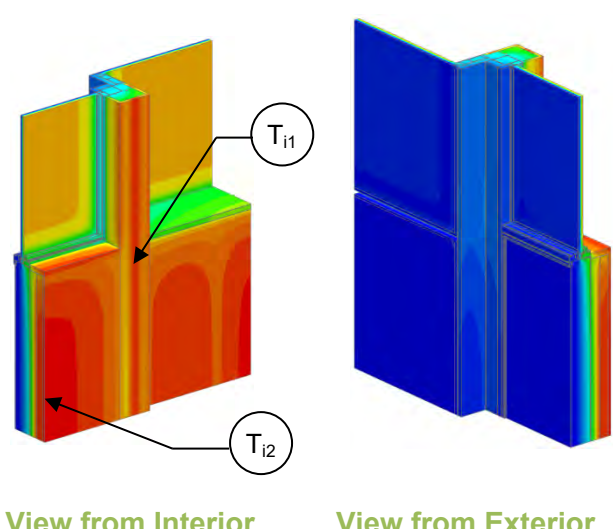

Assembly 1D (Nominal) R-Value	R_{1Dw}, R_{1Dcw}	Nominal thermal resistance of two base assemblies: w = window-wall R-15.7 (2.77 RSI) + backpan insulation cw= curtain-wall R-15.7 (2.77 RSI) + backpan insulation
Transmittance / Resistance without Anomaly	$U_w, R_w, U_{cw}, R_{cw}, U_g$	“clear wall” spandrel U- and R-value for the base assemblies g = glazing
Transmittance / Resistance	U, R	U and R-values for the assembly
Surface Temperature Index ¹	T_i	0 = exterior temperature 1 = interior temperature
Linear Transmittance	ψ	Incremental increase in transmittance per linear length of transition joint

¹Assumptions and limitations for surface temperatures identified in ASHRAE 1365-RP

Nominal (1D) vs. Assembly Performance Indicators

Base Assembly – Window Wall

Backpan Insulation 1D R-Value (RSI)	R_{1Dw} ft ² ·hr·°F / Btu (m ² K / W)	R_w ft ² ·hr·°F / Btu (m ² K / W)	U_w Btu/ft ² ·hr ·°F (W/m ² K)
R-8.4 (1.48)	R-24.1 (4.24)	R-7.6 (1.33)	0.132 (0.75)
R-16.8 (2.96)	R-32.5 (5.72)	R-10.8 (1.90)	0.093 (0.53)

Base Assembly – Curtain Wall

Backpan Insulation 1D R-Value (RSI)	R_{1Dcw} ft ² ·hr·°F / Btu (m ² K / W)	R_{cw} ft ² ·hr·°F / Btu (m ² K / W)	U_{cw} Btu/ft ² ·hr ·°F (W/m ² K)
R-8.4 (1.48)	R-24.1 (4.24)	R-7.3 (1.28)	0.136 (0.78)
R-16.8 (2.96)	R-32.5 (5.72)	R-10.1 (1.78)	0.099 (0.56)

Transition Joint Linear Transmittance

Backpan Insulation 1D R-Value (RSI)	R ft ² ·hr·°F / Btu (m ² K / W)	U Btu/ft ² ·hr ·°F (W/m ² K)	ψ Btu/ft ·hr ·°F (W/m K)
R-8.4 (1.48)	R-2.7 (0.47)	0.327 (2.11)	0.334 (0.578)
R-16.8 (2.96)	R-2.9 (0.51)	0.347 (1.97)	0.294 (0.509)

Base Assembly – Glazing

$U_{\text{centre of glass}}$ Btu/ft ² ·hr ·°F (W/m ² K)	U_g Btu/ft ² ·hr ·°F (W/m ² K)
0.321 (1.82)	0.373 (2.12)

Temperature Indices

	R8.4	R16.8	
T_{i1}	0.90	0.91	Min T on sprayfoam, along vertical mullion
T_{i2}	0.91	0.92	Max T on sprayfoam, at centre of backpan

4.0 High Performance Curtain Wall

Detail 4.1.1	B.4.1
High Performance Curtain Wall System – Spandrel Clear Wall & No Interior Stud Cavity Insulation	
Detail 4.1.2	B.4.2
High Performance Curtain Wall System – Spandrel Clear Wall & Interior Sprayfoam Insulation	
Detail 4.2.1	B.4.3
High Performance Curtain Wall System – Intermediate Floor Intersection & No Interior Stud Cavity Insulation	
Detail 4.2.2	B.4.4
High Performance Curtain Wall System – Intermediate Floor Intersection & Interior Sprayfoam Insulation	
Detail 4.2.3	B.4.5
High Performance Curtain Wall System with Vertical and Horizontal Pressure Plates and 5' x 5' Spandrel Section – Insulated Backpan and Intermediate Floor Intersection	
Detail 4.2.4	B.4.6
High Performance Curtain Wall System with Vertical and Horizontal Pressure Plates and 5' x 5' Spandrel Section – AIM Applications and Intermediate Floor Intersection	
Detail 4.2.5	B.4.7
High Performance Curtain Wall System with Vertical and Horizontal Pressure Plates, Intermediate Mullion and 5' x 5' Spandrel Section – Insulated Backpan and Intermediate Floor Intersection	
Detail 4.2.6	B.4.8
High Performance Curtain Wall System with Vertical and Horizontal Pressure Plates, Intermediate Mullion and 5' x 5' Spandrel Section – AIM Applications and Intermediate Floor Intersection	

Detail 4.1.1

High Performance Curtain Wall System – Spandrel Clear Wall & No Interior Stud Cavity Insulation

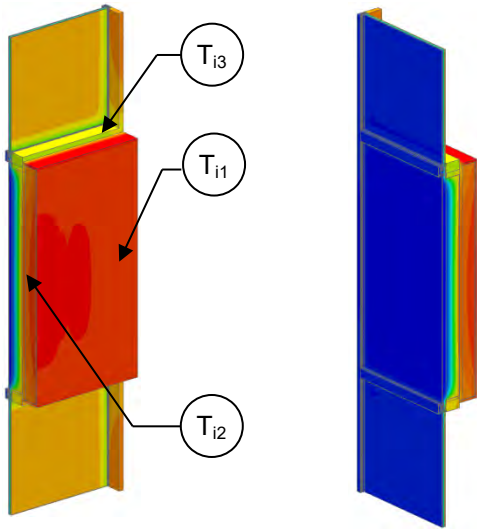

Thermal Performance Indicators

1.00	<table border="1"> <tr> <td>Assembly 1D (Nominal) R-Value</td> <td>R_{1D}</td> <td>R-3.7 (0.65 RSI) + backpan insulation</td> </tr> <tr> <td>Transmittance / Resistance</td> <td>U_w, R_w, U_g</td> <td>U-value and R-value for w = spandrel wall g = glazing, including framing</td> </tr> <tr> <td>Transmittance / Resistance</td> <td>U, R</td> <td>U- and R-values for overall assembly</td> </tr> <tr> <td>Surface Temperature Index¹</td> <td>T_i</td> <td>0 = exterior temperature 1 = interior temperature</td> </tr> </table>	Assembly 1D (Nominal) R-Value	R_{1D}	R-3.7 (0.65 RSI) + backpan insulation	Transmittance / Resistance	U_w, R_w, U_g	U-value and R-value for w = spandrel wall g = glazing, including framing	Transmittance / Resistance	U, R	U- and R-values for overall assembly	Surface Temperature Index ¹	T_i	0 = exterior temperature 1 = interior temperature
Assembly 1D (Nominal) R-Value		R_{1D}	R-3.7 (0.65 RSI) + backpan insulation										
Transmittance / Resistance		U_w, R_w, U_g	U-value and R-value for w = spandrel wall g = glazing, including framing										
Transmittance / Resistance		U, R	U- and R-values for overall assembly										
Surface Temperature Index ¹	T_i	0 = exterior temperature 1 = interior temperature											
0.90													
0.80													
0.70													
0.60													
0.50													
0.40													
0.30													
0.20													
0.10													
0.00													

¹Assumptions and limitations for surface temperatures identified in ASHRAE 1365-RP

View from Interior

View from Exterior

Nominal (1D) vs. Assembly Performance Indicators

Spandrel Section

Backpan Insulation 1D R-Value (RSI)	R_{1D} ft ² ·hr·°F / Btu (m ² K / W)	R_w ft ² ·hr·°F / Btu (m ² K / W)	U_w Btu/ft ² ·hr·°F (W/m ² K)
R-8.4 (1.48)	R-12.1 (2.13)	R-4.2 (0.74)	0.237 (1.35)
R-16.8 (2.96)	R-20.5 (3.61)	R-6.9 (1.22)	0.144 (0.82)

Glazing

$U_{\text{centre of glass}}$ Btu/ft ² ·hr·°F (W/m ² K)	U_g Btu/ft ² ·hr·°F (W/m ² K)
0.321 (1.82)	0.373 (2.12)

Combined Assembly

Backpan Insulation 1D R-Value (RSI)	R ft ² ·hr·°F / Btu (m ² K / W)	U Btu/ft ² ·hr·°F (W/m ² K)
R-8.4 (1.48)	R-3.3 (0.58)	0.302 (1.72)
R-16.8 (2.96)	R-3.9 (0.68)	0.259 (1.47)

Temperature Indices

	R8.4	R16.8	
T_{i1}	0.51	0.69	Min T on backpan, at edge of backpan
T_{i2}	0.80	0.87	Max T on backpan, at centre of backpan
T_{i3}	0.50	0.56	Min T on frame, at corner of glazing

Detail 4.1.2

High Performance Curtain Wall System – Spandrel Clear Wall & Interior Sprayfoam Insulation

Thermal Performance Indicators

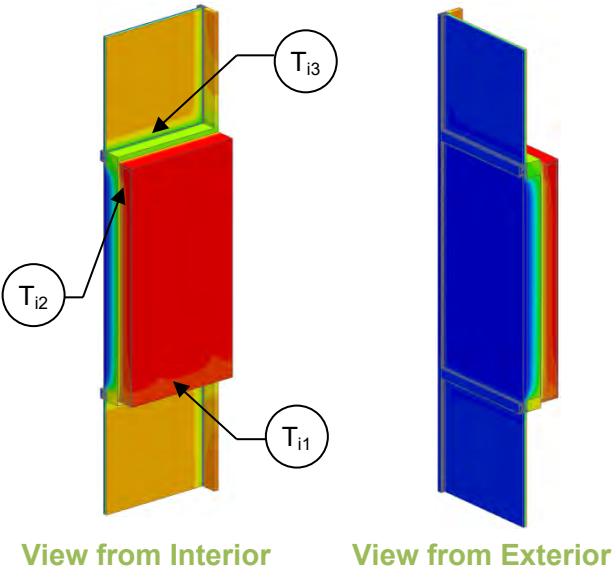

1.00	<table border="1"> <tr> <td>Assembly 1D (Nominal) R-Value</td> <td>R_{1D}</td> <td>R-15.7 (2.77 RSI) + backpan insulation</td> </tr> <tr> <td>Transmittance / Resistance</td> <td>U_w, R_w U_g</td> <td>U-value and R-value for w = spandrel wall g = glazing, including framing</td> </tr> <tr> <td>Transmittance / Resistance</td> <td>U, R</td> <td>U- and R-values for overall assembly</td> </tr> <tr> <td>Surface Temperature Index¹</td> <td>T_i</td> <td>0 = exterior temperature 1 = interior temperature</td> </tr> </table>	Assembly 1D (Nominal) R-Value	R _{1D}	R-15.7 (2.77 RSI) + backpan insulation	Transmittance / Resistance	U _w , R _w U _g	U-value and R-value for w = spandrel wall g = glazing, including framing	Transmittance / Resistance	U, R	U- and R-values for overall assembly	Surface Temperature Index ¹	T _i	0 = exterior temperature 1 = interior temperature
Assembly 1D (Nominal) R-Value		R _{1D}	R-15.7 (2.77 RSI) + backpan insulation										
Transmittance / Resistance		U _w , R _w U _g	U-value and R-value for w = spandrel wall g = glazing, including framing										
Transmittance / Resistance		U, R	U- and R-values for overall assembly										
Surface Temperature Index ¹	T _i	0 = exterior temperature 1 = interior temperature											
0.90													
0.80													
0.70													
0.60													
0.50													
0.40													
0.30													
0.20													
0.10													
0.00													

¹Assumptions and limitations for surface temperatures identified in ASHRAE 1365-RP

Nominal (1D) vs. Assembly Performance Indicators

Spandrel Section

Backpan Insulation 1D R-Value (RSI)	R _{1D} ft ² ·hr·°F / Btu (m ² K / W)	R _w ft ² ·hr·°F / Btu (m ² K / W)	U _w Btu/ft ² ·hr·°F (W/m ² K)
R-8.4 (1.48)	R-24.1 (4.24)	R-6.0 (1.05)	0.168 (0.95)
R-16.8 (2.96)	R-32.5 (5.72)	R-8.9 (1.56)	0.113 (0.64)

Glazing

U _{centre of glass} Btu/ft ² ·hr·°F (W/m ² K)	U _g Btu/ft ² ·hr·°F (W/m ² K)
0.321 (1.82)	0.367 (2.08)

Combined Assembly

Backpan Insulation 1D R-Value (RSI)	R ft ² ·hr·°F / Btu (m ² K / W)	U Btu/ft ² ·hr·°F (W/m ² K)
R-8.4 (1.48)	R-3.8 (0.67)	0.264 (1.50)
R-16.8 (2.96)	R-4.2 (0.73)	0.24 (1.36)

Temperature Indices

	R8.4	R16.8	
T _{i1}	0.74	0.81	Min T on spray foam, at bottom of spandrel
T _{i2}	0.94	0.95	Max T on spray foam, at top of spandrel, away from frame and studs
T _{i3}	0.44	0.50	Min T on frame, at corner of glazing

Detail 4.2.1

High Performance Curtain Wall System – Intermediate Floor Intersection & No Interior Stud Cavity Insulation

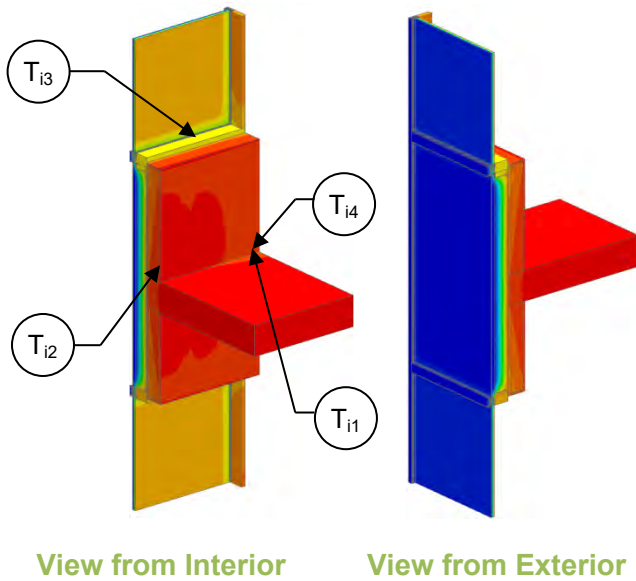

Thermal Performance Indicators

Assembly 1D (Nominal) R-Value	R_{1D}	R-3.7 (0.65 RSI) + backpan insulation
Transmittance / Resistance without Anomaly	U_w, R_w, U_g	“clear wall” U- and R-value, w = spandrel wall without slab, g = glazing
Transmittance / Resistance	U_s, R_s, U_t, R_t	U and R-values for s = spandrel with slab, t = combined glazing and spandrel with slab
Surface Temperature Index ¹	T_i	0 = exterior temperature, 1 = interior temperature
Linear Transmittance	ψ	Incremental increase in transmittance per linear length of slab

¹Assumptions and limitations for surface temperatures identified in ASHRAE 1365-RP

²Spandrel section includes interface with slab and vision glazing

Nominal (1D) vs. Assembly Performance Indicators

Base Assembly - Spandrel Section Only

Backpan Insulation 1D R-Value (RSI)	R_{1D} ft ² ·hr·°F / Btu (m ² K / W)	R_w ft ² ·hr·°F / Btu (m ² K / W)	U_w Btu/ft ² ·hr·°F (W/m ² K)
R-8.4 (1.48)	R-12.1 (2.13)	R-4.2 (0.74)	0.237 (1.35)
R-16.8 (2.96)	R-20.5 (3.61)	R-6.9 (1.22)	0.144 (0.82)

Base Assembly - Glazing

$U_{\text{centre of glass}}$ Btu/ft ² ·hr·°F (W/m ² K)	U_g Btu/ft ² ·hr·°F (W/m ² K)
0.321 (1.82)	0.373 (2.12)

Slab Linear Transmittance

Backpan Insulation 1D R-Value (RSI)	R_t ft ² ·hr·°F / Btu (m ² K / W)	U_t Btu/ft ² ·hr·°F (W/m ² K)	ψ Btu/ft·hr·°F (W/m K)
R-8.4 (1.48)	R-3.3 (0.58)	0.306 (1.74)	0.037 (0.064)
R-16.8 (2.96)	R-3.8 (0.68)	0.260 (1.48)	0.016 (0.028)

Spandrel Section with Slab²

R_s ft ² ·hr·°F / Btu (m ² K / W)	U_s Btu/ft ² ·hr·°F (W/m ² K)
R-4.1 (0.72)	0.244 (1.39)
R-6.8 (1.20)	0.147 (0.83)

Temperature Indices

	R8.4	R16.8	
T_{i1}	0.53	0.71	Min T on backpan, at anchor
T_{i2}	0.81	0.88	Max T on backpan, at centre of backpan above slab
T_{i3}	0.51	0.57	Min T on frame, along edge of glazing
T_{i4}	0.55	0.71	Min T on slab anchor

Detail 4.2.2

High Performance Curtain Wall System – Intermediate Floor Intersection & Interior Sprayfoam Insulation

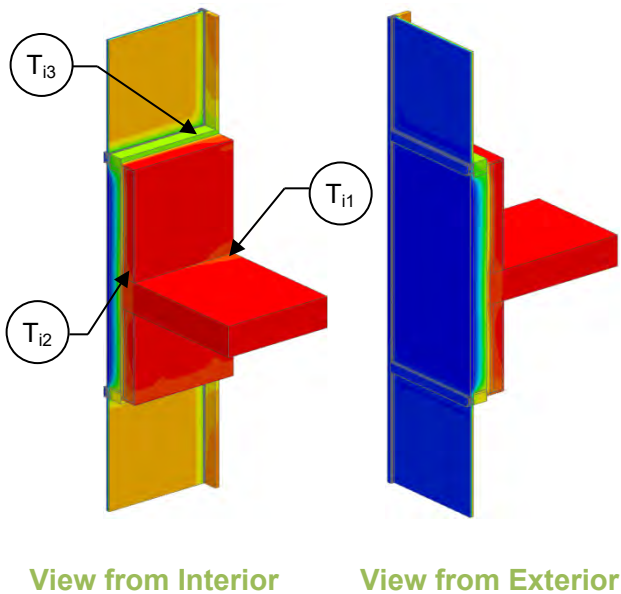

Thermal Performance Indicators

Assembly 1D (Nominal) R-Value	R_{1D}	R-15.7 (2.77 RSI) + backpan insulation
Transmittance / Resistance without Anomaly	U_w, R_w, U_g	“clear wall” U- and R-value, w = spandrel wall without slab, g = glazing
Transmittance / Resistance	U_s, R_s, U_t, R_t	U and R-values for s = spandrel with slab, t = combined glazing and spandrel with slab
Surface Temperature Index ¹	T_i	0 = exterior temperature, 1 = interior temperature
Linear Transmittance	ψ	Incremental increase in transmittance per linear length of slab

¹Assumptions and limitations for surface temperatures identified in ASHRAE 1365-RP

²Spandrel section includes interface with slab and vision glazing

Nominal (1D) vs. Assembly Performance Indicators

Base Assembly - Spandrel Section Only

Backpan Insulation 1D R-Value (RSI)	R_{1D} ft ² ·hr·°F / Btu (m ² K / W)	R_w ft ² ·hr·°F / Btu (m ² K / W)	U_w Btu/ft ² ·hr·°F (W/m ² K)
R-8.4 (1.48)	R-24.1 (4.24)	R-6.0 (1.05)	0.168 (0.95)
R-16.8 (2.96)	R-32.5 (5.72)	R-8.9 (1.56)	0.113 (0.64)

Base Assembly - Glazing

$U_{\text{centre of glass}}$ Btu/ft ² ·hr·°F (W/m ² K)	U_g Btu/ft ² ·hr·°F (W/m ² K)
0.321 (1.82)	0.367 (2.08)

Slab Linear Transmittance

Backpan Insulation 1D R-Value (RSI)	R_t ft ² ·hr·°F / Btu (m ² K / W)	U_t Btu/ft ² ·hr·°F (W/m ² K)	ψ Btu/ft·hr·°F (W/m K)
R-8.4 (1.48)	R-3.7 (0.64)	0.274 (1.55)	0.093 (0.161)
R-16.8 (2.96)	R-4.1 (0.72)	0.245 (1.39)	0.050 (0.087)

Spandrel Section with Slab²

R_s ft ² ·hr·°F / Btu (m ² K / W)	U_s Btu/ft ² ·hr·°F (W/m ² K)
R-5.4 (0.95)	0.186 (1.05)
R-8.2 (1.45)	0.122 (0.69)

Temperature Indices

	R8.4	R16.8	
T_{i1}	0.68	0.77	Min T on spray foam, around slab anchor
T_{i2}	0.95	0.96	Max T on spray foam, at top of spandrel, away from frame and studs
T_{i3}	0.45	0.51	Min T on frame, along edge of glazing

Detail 4.2.3

High Performance Curtain Wall System with Vertical and Horizontal Pressure Plates and 5' x 5' Spandrel Section – Insulated Backpan and Intermediate Floor Intersection

Thermal Performance Indicators

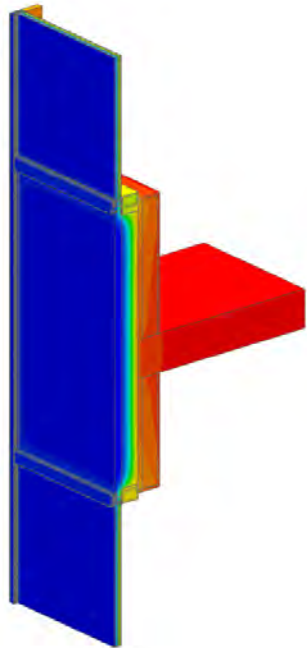

View from Exterior

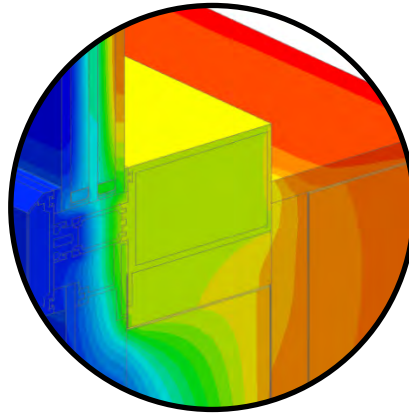

Mullion Detail



Transmittance / Resistance	U_s, R_s	Spandrel Section U-value and “Effective” R-value (including slab)
	U_g, R_g	Glazing U-value and “Effective” R-value
	U_t, R_t	Total Assembly U-value and “Effective” R-value

¹ U_t based on a window to wall ratio of 50%, but U_s is valid for all spandrel dimensions.

Scenario

Scenario	Vision Glass and Spacer	Insulation Thickness and Application
A	Triple Glazed with Aluminum Spacer	4" (100 mm) Mineral Wool in Backpan

Nominal (1D) vs. Assembly Performance Indicators

Scenario	Insulation R-Value (RSI)	U_s Btu/ft ² · hr · °F (W/m ² K)	R_s ft ² · hr · °F / Btu (m ² K / W)	U_g Btu/ft ² · hr · °F (W/m ² K)	R_g ft ² · hr · °F / Btu (m ² K / W)	U_t ¹ Btu/ft ² · hr · °F (W/m ² K)	R_t ft ² · hr · °F / Btu (m ² K / W)
A	R-16.8 (2.96)	0.156 (0.89)	R-6.4 (1.13)	0.238 (1.35)	R-4.2 (0.74)	0.197 (1.12)	R-5.1 (0.89)

Detail 4.2.4

High Performance Curtain Wall System with Vertical and Horizontal Pressure Plates and 5' x 5' Spandrel Section – AIM Applications and Intermediate Floor Intersection

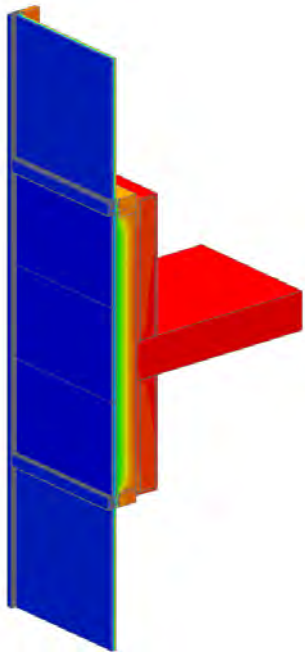

View from Exterior

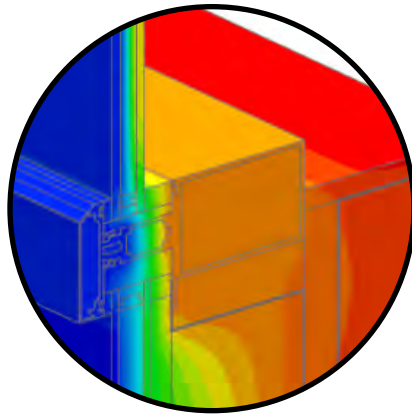

Mullion Detail

Thermal Performance Indicators

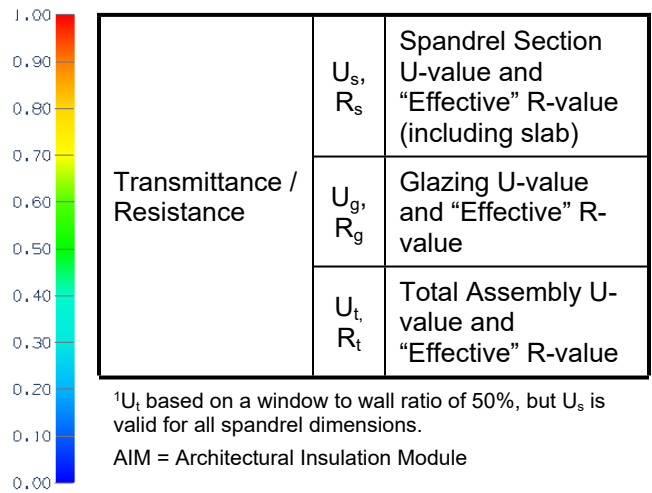

Scenarios

Scenario	Vision Glass and Spacer	Insulation Thickness and Application	AIM Spacer/Edge Condition
A	Double Glazed with Silicone Warm Edge Spacer	0.75" (19 mm) AIM between Glass + 4" (100 mm) Mineral Wool in Backpan	Silicone Warm Edge Spacer
B	Double Glazed with Silicone Warm Edge Spacer	1.5" (38 mm) AIM between Glass + 4" (100 mm) Mineral Wool in Backpan	Silicone Warm Edge Spacer
C	Triple Glazed with Silicone Warm Edge Spacer	1.5" (38 mm) AIM between Glass + 4" (100 mm) Mineral Wool in Backpan	Silicone Warm Edge Spacer
D	Triple Glazed with Silicone Warm Edge Spacer	Shadow AIM with 5/8" (16mm) AIM in Secondary Unit + 4" (100 mm) Mineral Wool in Backpan	Silicone Warm Edge Spacer

Nominal (1D) vs. Assembly Performance Indicators

Scenario	Insulation R-Value (RSI)	U_s Btu/ft ² ·hr·°F (W/m ² K)	R_s ft ² ·hr·°F / Btu (m ² K / W)	U_g Btu/ft ² ·hr·°F (W/m ² K)	R_g ft ² ·hr·°F / Btu (m ² K / W)	U_t^1 Btu/ft ² ·hr·°F (W/m ² K)	R_t ft ² ·hr·°F / Btu (m ² K / W)
A	R-46.1 (8.12)	0.086 (0.49)	R-11.7 (2.06)	0.359 (2.04)	R-2.8 (0.49)	0.222 (1.26)	R-4.5 (0.79)
B	R-75.4 (13.28)	0.075 (0.43)	R-13.3 (2.34)	0.361 (2.05)	R-2.8 (0.49)	0.218 (1.24)	R-4.6 (0.81)
C	R-75.4 (13.28)	0.072 (0.41)	R-13.8 (2.43)	0.240 (1.36)	R-4.2 (0.73)	0.156 (0.89)	R-6.4 (1.13)
D	R-41.2 (7.26)	0.090 (0.51)	R-11.2 (1.96)	0.229 (1.30)	R-4.4 (0.77)	0.159 (0.90)	R-6.3 (1.11)

Detail 4.2.5

High Performance Curtain Wall System with Vertical and Horizontal Pressure Plates, Intermediate Mullion and 5' x 5' Spandrel Section – Insulated Backpan and Intermediate Floor Intersection

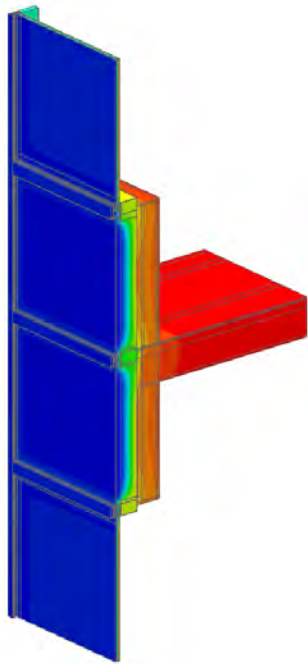

View from Exterior

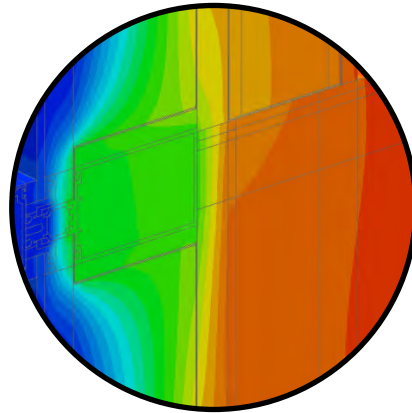

Mullion Detail

Thermal Performance Indicators

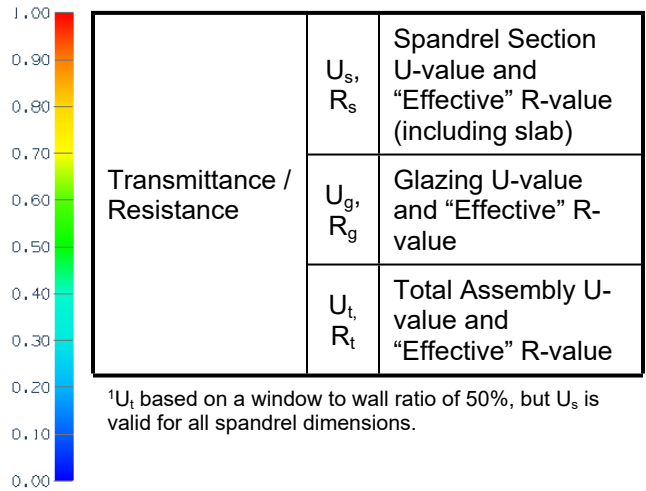

Scenario

Scenario	Vision Glass and Spacer	Insulation Thickness and Application
A	Double Glazed with Silicone Warm Edge Spacer	4" (100 mm) Mineral Wool in Backpan

Nominal (1D) vs. Assembly Performance Indicators

Scenario	Insulation R-Value (RSI)	U_s Btu/ft ² ·hr·°F (W/m ² K)	R_s ft ² ·hr·°F / Btu (m ² K / W)	U_g Btu/ft ² ·hr·°F (W/m ² K)	R_g ft ² ·hr·°F / Btu (m ² K / W)	U_t^1 Btu/ft ² ·hr·°F (W/m ² K)	R_t ft ² ·hr·°F / Btu (m ² K / W)
A	R-16.8 (2.96)	0.204 (1.16)	R-4.9 (0.86)	0.357 (2.03)	R-2.8 (0.49)	0.281 (1.59)	R-3.6 (0.63)

Detail 4.2.6

High Performance Curtain Wall System with Vertical and Horizontal Pressure Plates, Intermediate Mullion and 5' x 5' Spandrel Section – AIM Applications and Intermediate Floor Intersection

Thermal Performance Indicators

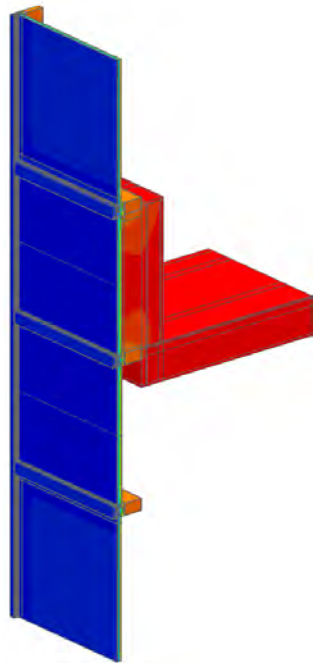

View from Exterior

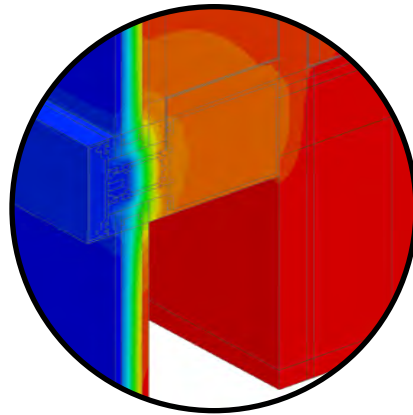

Mullion Detail



Transmittance / Resistance	U_s, R_s	Spandrel Section U-value and “Effective” R-value (including slab)
	U_g, R_g	Glazing U-value and “Effective” R-value
	U_t, R_t	Total Assembly U-value and “Effective” R-value

¹ U_t based on a window to wall ratio of 50%, but U_s is valid for all spandrel dimensions.

AIM = Architectural Insulation Module

Scenarios

Scenario	Vision Glass and Spacer	Insulation Thickness and Application	AIM Spacer/Edge Condition
A	Double Glazed with Silicone Warm Edge Spacer	0.75" (19 mm) AIM between Glass	Silicone Warm Edge Spacer
B	Double Glazed with Silicone Warm Edge Spacer	1" (25mm) AIM between Metal Skins	Rigid Insulation
C	Triple Glazed with Silicone Warm Edge Spacer	1.5" (38 mm) AIM between Glass	Silicone Warm Edge Spacer

Nominal (1D) vs. Assembly Performance Indicators

Scenario	Insulation R-Value (RSI)	U_s Btu/ft ² · hr · °F (W/m ² K)	R_s ft ² · hr · °F / Btu (m ² K / W)	U_g Btu/ft ² · hr · °F (W/m ² K)	R_g ft ² · hr · °F / Btu (m ² K / W)	U_t^1 Btu/ft ² · hr · °F (W/m ² K)	R_t ft ² · hr · °F / Btu (m ² K / W)
A	R-29.3 (5.16)	0.141 (0.80)	R-7.1 (1.25)	0.361 (2.05)	R-2.8 (0.49)	0.251 (1.43)	R-4.0 (0.70)
B	R-39.1 (6.89)	0.112 (0.63)	R-8.9 (1.57)	0.357 (2.03)	R-2.8 (0.49)	0.234 (1.33)	R-4.3 (0.75)
C	R-58.6 (10.32)	0.098 (0.55)	R-10.2 (1.80)	0.220 (1.25)	R-4.5 (0.80)	0.159 (0.90)	R-6.3 (1.11)

5.0 Steel-Frame Construction

Detail 5.1.1	B.5.1
Interior Insulated 3 5/8" x 1 5/8" Steel Stud Wall Assembly – Clear Wall	
Detail 5.1.2	B.5.2
Interior Insulated 6" x 1 5/8" Steel Stud Wall Assembly – Clear Wall	
Detail 5.1.3	B.5.3
Exterior Insulated 3 5/8" x 1 5/8" Steel Stud (16" o.c.) Drained EIFS Wall Assembly – Clear Wall	
Detail 5.1.4	B.5.4
Exterior and Interior Insulated 3 5/8" x 1 5/8" Steel Stud (16" o.c.) Drained EIFS Wall Assembly with R-12 Batt Insulation in Stud Cavity – Clear Wall	
Detail 5.1.5	B.5.5
Exterior Insulated 3 5/8" x 1 5/8" Steel Stud (16" o.c.) Wall Assembly with Vertical Z-Girts (16" o.c.) Supporting Metal Cladding – Clear Wall	
Detail 5.1.6	B.5.6
Exterior and Interior Insulated 6" x 1 5/8" Steel Stud (16" o.c.) Wall Assembly with Vertical Z-Girts (16" o.c.) Supporting Metal Cladding and R-20 Batt Insulation in Stud Cavity – Clear Wall	
Detail 5.1.7	B.5.7
Exterior and Interior Insulated 6" x 1 5/8" Steel Stud (16" o.c.) Wall Assembly with Vertical Z-Girts (16" o.c.) and 1 1/2" Spray Foam (R-9.8) in Stud Cavity – Clear Wall	
Detail 5.1.8	B.5.8
Exterior and Interior Insulated 6" x 1 5/8" Steel Stud (16" o.c.) Wall Assembly with Vertical Z-Girts (16" o.c.) and 2" Spray Foam (R-11.4) in Stud Cavity – Clear Wall	
Detail 5.1.9	B.5.9
Exterior Insulated 3 5/8" x 1 5/8" Steel Stud (16" O.C.) Wall Assembly with Horizontal Z-Girts (24" O.C.) Supporting Metal Cladding – Clear Wall	
Detail 5.1.10	B.5.10
Exterior and Interior Insulated 6" x 1 /58" Steel Stud (16" o.c.) Wall Assembly with Horizontal Z-Girts (24" o.c.) Supporting Cladding, Owens Corning ThermaFiber RainBarrier HC Max Insulation and R-20 Batt Insulation in Stud Cavity – Clear Wall	
Detail 5.1.11	B.5.11
Exterior and Interior Insulated 6" x 1 5/8" Steel Stud (16" o.c.) Wall Assembly with Horizontal Z-Girts (24" o.c.) Supporting Cladding, Owens Corning ThermaFiber RainBarrier HC Plus 110 Insulation and R-20 Batt Insulation in Stud Cavity – Clear Wall	
Detail 5.1.12	B.5.12

Exterior and Interior Insulated 6" x 1 5/8" Steel Stud (16" o.c.) Wall Assembly with Horizontal Z-Girts (24" o.c.) Supporting Cladding, Owens Corning ThermaFiber RainBarrier 45 Insulation and R-20 Batt Insulation in Stud Cavity – Clear Wall	
Detail 5.1.13	B.5.13
Exterior and Interior Insulated 3 5/8" x 1 5/8" Steel Stud (16" o.c.) Wall Assembly with Vertical Z-girts (16" o.c.) Supporting Stucco Cladding and R-12 Batt Insulation in Stud Cavity – Clear Wall	
Detail 5.1.14	B.5.14
Exterior and Interior Insulated 3 5/8" x 1 5/8" Steel Stud (16" o.c.) Wall Assembly with Horizontal Z-Girts (24" o.c.) Supporting Metal Cladding and R-12 Batt Insulation in Stud Cavity – Clear Wall	
Detail 5.1.15	B.5.15
Exterior and Interior Insulated 6" x 1 5/8" Steel Stud (16" o.c.) Wall Assembly with Horizontal Z-Girts (24" o.c.) and 1 1/2" Spray Foam (R-9.8) in Stud Cavity – Clear Wall	
Detail 5.1.16	B.5.16
Exterior Insulated 3 5/8" x 1 5/8" Steel Stud (16" O.C.) Wall Assembly with Vertical Z-Girts (24" O.C.) & Horizontal Z-Girts (24" O.C.) Supporting Metal Cladding – Clear Wall	
Detail 5.1.17	B.5.17
Exterior Insulated 3 5/8" x 1 5/8" Steel Stud (16" O.C.) Wall Assembly with Intermittent Vertical Z-Girts (16" O.C.) Supporting Metal Cladding – Clear Wall	
Detail 5.1.18	B.5.18
Exterior Insulated 3 5/8" x 1 5/8" Steel Stud (16" o.c.) Wall Assembly with Horizontal Clips (24" o.c.) Supporting Metal Cladding – Clear Wall	
Detail 5.1.19	B.5.19
Exterior and Interior Insulated 3 5/8" x 1 5/8" Steel Stud (16" o.c.) Wall Assembly with Horizontal Clips (24" o.c.) Supporting Metal Cladding and R-12 Batt Insulation in Stud Cavity – Clear Wall	
Detail 5.1.20	B.5.20
Exterior and Interior Insulated 3 5/8" x 1 5/8" Steel Stud (16" o.c.) Wall Assembly with Vertical Z Clips (16" o.c.) Supporting Stucco Cladding and R-12 Batt Insulation in Stud Cavity – Clear Wall	
Detail 5.1.21	B.5.21
Exterior Insulated 6" x 1 5/8" Steel Stud (16" o.c.) Wall Assembly with Knight MFI-System (24" o.c.) Supporting Cladding – Clear Wall	
Detail 5.1.22	B.5.22
Exterior and Interior Insulated 6" x 1 5/8" Steel Stud (16" o.c.) Wall Assembly with Knight MFI-System (24" o.c.) Supporting Cladding and R-19 Batt Insulation in Stud Cavity – Clear Wall	
Detail 5.1.23	B.5.23

Exterior Insulated 3 5/8" x 1 5/8" Steel Stud (16" o.c.) Wall Assembly with CL-Talon 300 Clip System Supporting Cladding – Clear Wall	
Detail 5.1.24	B.5.24
Exterior Insulated 3 5/8" x 1 5/8" Steel Stud (16" o.c.) Wall Assembly with Thermally Isolated Aluminum Clip Horizontal Sub-girt System Supporting Cladding – Clear Wall	
Detail 5.1.25	B.5.25
Exterior Insulated 3 5/8" x 1/58" Steel Stud (16" o.c.) Wall Assembly with Fiber Reinforced Girts (TAC) Supporting Cladding – Clear Wall	
Detail 5.1.26	B.5.26
Exterior Insulated 3 5/8" x 1 5/8" Steel Stud (16" o.c.) Wall Assembly with Thermally Broken Aluminum Clip Rail System (24" o.c.) Supporting Cladding – Clear Wall	
Detail 5.1.27	B.5.27
Exterior and Interior Insulated 6" x 1 5/8" Steel Stud (16" o.c.) Wall Assembly with High Compression Insulation and Through Insulation Steel Fasteners (12" o.c.) Supporting Cladding, Owens Corning ThermaFiber RainBarrier HC Max Insulation and R-20 Batt Insulation in Stud Cavity – Clear Wall	
Detail 5.1.28	B.5.28
Exterior and Interior Insulated 6" x 1 5/8" Steel Stud (16" o.c.) Wall Assembly with High Compression Insulation and Through Insulation Steel Fasteners (12" o.c.) Supporting Cladding, Owens Corning ThermaFiber RainBarrier HC Plus 110 Insulation and R-20 Batt Insulation in Stud Cavity – Clear Wall	
Detail 5.1.29	B.5.29
Exterior and Interior Insulated 6" x 1 5/8" Steel Stud (16" o.c.) Wall Assembly with High Compression Insulation and Through Insulation Steel Fasteners (12" o.c.) Supporting Cladding, Owens Corning ThermaFiber RainBarrier 45 Insulation and R-20 Batt Insulation in Stud Cavity – Clear Wall	
Detail 5.1.30	B.5.30
Exterior and Interior Insulated 6" x 1 5/8" Steel Stud (16" o.c.) Wall Assembly with High Compression Insulation and Through Insulation Steel Fasteners (12" o.c.) Supporting Cladding, Owens Corning ThermaFiber RainBarrier HC Max Insulation and R-22 Batt Insulation in Stud Cavity – Clear Wall	
Detail 5.1.31	B.5.31
Exterior and Interior Insulated 6" x 1 5/8" Steel Stud (16" o.c.) Wall Assembly with High Compression Insulation and Through Insulation Steel Fasteners (12" o.c.) Supporting Cladding, Owens Corning ThermaFiber RainBarrier HC Plus 110 Exterior Insulation and R-22 Batt Insulation in Stud Cavity – Clear Wall	
Detail 5.1.32	B.5.32
Exterior and Interior Insulated 6" x 1 5/8" Steel Stud (16" o.c.) Wall Assembly with High Compression Insulation and Through Insulation Steel Fasteners (12" o.c.) Supporting Cladding, Owens Corning ThermaFiber RainBarrier 45 Insulation and R-22 Batt Insulation in Stud Cavity – Clear Wall	

- Detail 5.1.33**.....**B.5.33**
 Exterior and Interior Insulated 6" x 1 5/8" Steel Stud (16" o.c.) Wall Assembly with High Compression Insulation and Through Insulation Steel Fasteners (12" o.c.) Supporting Cladding, Owens Corning ThermaFiber RainBarrier HC Max Insulation and R-24 Batt Insulation in Stud Cavity – Clear Wall
- Detail 5.1.34**.....**B.5.34**
 Exterior and Interior Insulated 6" x 1 5/8" Steel Stud (16" o.c.) Wall Assembly with High Compression Insulation and Through Insulation Steel Fasteners (12" o.c.) Supporting Cladding, Owens Corning ThermaFiber RainBarrier HC Plus 110 Exterior Insulation and R-24 Batt Insulation in Stud Cavity – Clear Wall
- Detail 5.1.35**.....**B.5.35**
 Exterior and Interior Insulated 6" x 1 5/8" Steel Stud (16" o.c.) Wall Assembly with High Compression Insulation and Through Insulation Steel Fasteners (12" o.c.) Supporting Cladding, Owens Corning ThermaFiber RainBarrier 45 Insulation and R-24 Batt Insulation in Stud Cavity – Clear Wall
- Detail 5.1.36**.....**B.5.36**
 Exterior and Interior Insulated 6" x 1 5/8" Steel Stud (16" o.c.) Wall Assembly with Knight CI-System (8" o.c.) and 1 1/2" Spray Foam (R-9.8) in Stud Cavity – Clear Wall
- Detail 5.1.37**.....**B.5.37**
 Exterior and Interior Insulated 6" x 1 5/8" Steel Stud (16" o.c.) Wall Assembly with Knight CI-System (16" o.c.) and 1 1/2" Spray Foam (R-9.8) in Stud Cavity – Clear Wall
- Detail 5.1.38**.....**B.5.38**
 Exterior Insulated 6" x 1 5/8" Steel Stud (16" o.c.) Wall Assembly with Knight CI-System (8" o.c.) – Clear Wall
- Detail 5.1.39**.....**B.5.39**
 Exterior Insulated 3 5/8" x 1 5/8" Steel Stud (16" o.c.) Wall Assembly with R-TEC CI Bracket System Supporting Vertical Sub-girts – Clear Wall
- Detail 5.1.40**.....**B.5.40**
 Exterior and Interior Insulated 3 5/8" x 1 5/8" Steel Stud (16" o.c.) Wall Assembly with R-TEC CI Bracket System Supporting Vertical Sub-girts and R-13 Batt Insulation in Stud Cavity – Clear Wall
- Detail 5.1.41**.....**B.5.41**
 Exterior Insulated 3 5/8" x 1 5/8" Steel Stud (16" o.c.) Wall Assembly with Thermally Broken ISO Clip System Supporting Vertical Sub-girts – Clear Wall
- Detail 5.1.42**.....**B.5.42**
 Exterior Insulated 3 5/8" x 1 5/8" Steel Stud (16" o.c.) Wall Assembly with Thermally Broken ISO Clip System Supporting Horizontal Sub-girts – Clear Wall
- Detail 5.1.43**.....**B.5.43**

Exterior and Interior Insulated 3 5/8" x 1 5/8" Steel Stud (16" o.c.) Wall Assembly with Thermally Broken ISO Clip System Supporting Vertical Sub-girts and R-12 Batt Insulation in Stud Cavity – Clear Wall	
Detail 5.1.44	B.5.44
Exterior and Interior Insulated 3 5/8" x 1 5/8" Steel Stud (16" o.c.) Wall Assembly with Thermally Broken ISO Clip System Supporting Horizontal Sub-girts and R-12 Batt Insulation in Stud Cavity – Clear Wall	
Detail 5.1.45	B.5.45
Exterior Insulated 3 5/8" x 1 5/8" Steel Stud (16" o.c.) Wall Assembly with Thermally Broken ISO Clip System (16" o.c.) Supporting Horizontal and Vertical Sub-girts – Clear Wall	
Detail 5.1.46	B.5.46
Exterior Insulated 3 5/8" x 1 5/8" Steel Stud (16" o.c.) Wall Assembly with Thermally Broken ISO Clip System (32" o.c.) Supporting Horizontal and Vertical Sub-girts – Clear Wall	
Detail 5.1.47	B.5.47
Exterior Insulated 3 5/8" x 1 5/8" Steel Stud (16" o.c.) Wall Assembly with Nvelope – NV1 Clip System Supporting Cladding – Clear Wall	
Detail 5.1.48	B.5.48
Exterior and Interior Insulated 3 5/8" x 1 5/8" Steel Stud (16" o.c.) Wall Assembly with Nvelope – NV1 Clip System Supporting Cladding and R-12 Batt Insulation in Stud Cavity – Clear Wall	
Detail 5.1.49	B.5.49
Exterior and Interior Insulated 6" x 1 5/8" Steel Stud (16" o.c.) Wall Assembly with Nvelope – NV1 Clip System Supporting Cladding and R-19 Batt Insulation in Stud Cavity – Clear Wall	
Detail 5.1.50	B.5.50
Exterior and Interior Insulated 6" x 1 5/8" Slotted Steel R-Stud (16" o.c.) Wall Assembly with Nvelope – NV1 Clip System Supporting Cladding and R-19 Batt Insulation in Stud Cavity – Clear Wall	
Detail 5.1.51	B.5.51
Exterior and Interior Insulated 3 5/8" x 1 5/8" Steel Stud (16" o.c.) Wall Assembly with Nvelope – Eko Thermobacket Clip System Supporting Cladding and R-13 Batt Insulation in Stud Cavity – Clear Wall	
Detail 5.1.52	B.5.52
Exterior and Interior Insulated 3 5/8" x 1 5/8" Steel Stud (16" o.c.) Wall Assembly with Nvelope – Eko Thermobacket and NV1 Clip System Supporting Cladding and R-13 Batt Insulation in Stud Cavity – Clear Wall	
Detail 5.1.53	B.5.53
Exterior Insulated 3 5/8" x 1 5/8" Steel Stud (16" O.C.) Wall Assembly with Cascadia Clip Fiberglass Thermal Spacers – Clear Wall	
Detail 5.1.54	B.5.54

Exterior and Interior Insulated 6" x 1 5/8" Steel Stud (16" o.c. and 24" o.c.) Wall Assembly with Vertical Clips (24" o.c. and 36" o.c.) Supporting Cladding and Owens Corning R-20 Batt Insulation in Stud Cavity – Clear Wall	
Detail 5.1.55	B.5.55
Exterior and Interior Insulated 6" x 1 5/8" Steel Stud (16" o.c. and 24" o.c.) Wall Assembly with Vertical Clips (24" O.C. and 36" o.c.) Supporting Cladding and Owens Corning R-22.5 Batt Insulation in Stud Cavity– Clear Wall	
Detail 5.1.56	B.5.56
Exterior and Interior Insulated 6" x 1 5/8" Steel Stud (16" o.c. and 24" o.c.) Wall Assembly with Vertical Clips (24" O.C. and 36" o.c.) Supporting Cladding and Owens Corning R-24 Batt Insulation in Stud Cavity– Clear Wall	
Detail 5.1.57	B.5.57
Exterior Insulated 6" x 1 5/8" Steel Stud (16" o.c. and 24" o.c.) Wall Assembly with Vertical Clips (24" o.c. and 36" o.c.) Supporting Cladding – Clear Wall	
Detail 5.1.58	B.5.58
Owens Corning Exterior Insulated 6" x 1 5/8" Steel Stud (16" o.c.) Wall Assembly with Thermally Isolated Vertical Brackets and Rail System (24" o.c.) Supporting Metal Cladding – Clear Wall	
Detail 5.1.59	B.5.59
Exterior and Interior Insulated 6" x 1 5/8" Steel Stud (16" o.c. and 24" o.c.) Wall Assembly with Vertical Clips (24" o.c. and 36" o.c.) Supporting Cladding and R-20 Batt Insulation in Stud Cavity – Clear Wall	
Detail 5.1.60	B.5.60
Exterior and Interior Insulated 6" x 1 5/8" Steel Stud (16" o.c. and 24" o.c.) Wall Assembly with Steel Brick Anchors Supporting Brick Veneer and Owens Corning R-20 Batt Insulation in Stud Cavity – Clear Wall	
Detail 5.1.61	B.5.61
Exterior and Interior Insulation 6" x 1 5/8" Steel Stud (16" o.c. and 24" o.c.) Wall Assembly with Brick Ties Supporting Brick Veneer and Owens Corning R-22.5 Batt Insulation in Stud Cavity – Clear Wall	
Detail 5.1.62	B.5.62
Exterior and Interior Insulated 6" x 1 5/8" Steel Stud (16" o.c. and 24" o.c.) Wall Assembly with Brick Ties Supporting Brick Veneer and Owens Corning R-24 Batt Insulation in Stud Cavity – Clear Wall	
Detail 5.1.63	B.5.63
Exterior and Interior Insulated 6" x 1 5/8" Steel Stud (16" o.c.) Wall Assembly with Heckmann Pos-I-Tie Veneer Anchoring System Supporting Brick Veneer and Owens Corning R-20 Batt Insulation in Stud Cavity – Clear Wall	
Detail 5.1.64	B.5.64
Exterior and Interior Insulated 6" x 1 5/8" Steel Stud (16" o.c.) Wall Assembly with Heckmann Pos-I-Tie Veneer Anchoring System Supporting Brick Veneer and Owens Corning R-22.5 Batt Insulation in Stud Cavity – Clear Wall	

- Detail 5.1.65**.....**B.5.65**
 Exterior and Interior Insulated 6" x 1 5/8" Steel Stud (16" o.c.) Wall Assembly with Heckmann Pos-I-Tie Veneer Anchoring System Supporting Brick Veneer and Owens Corning R-24 Batt Insulation in Stud Cavity – Clear Wall
- Detail 5.1.66**.....**B.5.66**
 Exterior and Interior Insulated 6" x 1 5/8" Steel Stud (16" o.c.) Wall Assembly with Steel Anchor Supporting Brick Veneer, Owens Corning XPS Exterior Insulation and R-20 Batt Insulation in Stud Cavity – Clear Wall
- Detail 5.1.67**.....**B.5.67**
 Exterior Insulated 3 5/8" x 1 5/8" Steel Stud (16" o.c.) Wall Assembly with Hohmann & Barnard Masonry Zinc 2-Seal Anchor Supporting Brick Veneer – Clear Wall
- Detail 5.1.68**.....**B.5.68**
 Exterior Insulated 3 5/8" x 1 5/8" Steel Stud (16" o.c.) Wall Assembly with Hohmann & Barnard Masonry Stainless Steel 2-Seal Thermal Anchor Supporting Brick Veneer – Clear Wall
- Detail 5.1.69**.....**B.5.69**
 Exterior Insulated 3 5/8" x 1 5/8" Steel Stud (16" o.c.) Wall Assembly with Hohmann & Barnard Masonry Stainless Steel 2-Seal Thermal Wing Nut Anchor Supporting Brick Veneer – Clear Wall
- Detail 5.1.70**.....**B.5.70**
 Exterior Insulated 3 5/8" x 1 5/8" Steel Stud (16" o.c.) Wall Assembly with Hohmann & Barnard Masonry Carbon Steel X-Seal Anchor Supporting Brick Veneer – Clear Wall
- Detail 5.1.71**.....**B.5.71**
 Exterior Insulated 3 5/8" x 1 5/8" Steel Stud (16" o.c.) Wall Assembly with Hohmann & Barnard Masonry Stainless Steel X-Seal Anchor Supporting Brick Veneer – Clear Wall
- Detail 5.1.72**.....**B.5.72**
 Exterior Insulated 3 5/8" x 1 5/8" Steel Stud (16" o.c.) Wall Assembly with Hohmann & Barnard Masonry Carbon Steel HB-213 2X Anchor Supporting Brick Veneer – Clear Wall
- Detail 5.1.73**.....**B.5.73**
 Exterior Insulated 3 5/8" x 1 5/8" Steel Stud (16" o.c.) Wall Assembly with Hohmann & Barnard Masonry Stainless Steel HB-213 2X Anchor Supporting Brick Veneer – Clear Wall
- Detail 5.1.74**.....**B.5.74**
 Exterior Insulated 3 5/8" x 1 5/8" Steel Stud (16" o.c.) Wall Assembly with Hohmann & Barnard Masonry Carbon Steel HB-200-X Steel Tie Supporting Brick Veneer – Clear Wall
- Detail 5.1.75**.....**B.5.75**

Exterior Insulated 3 5/8" x 1 5/8" Steel Stud (16" o.c.) Wall Assembly with Hohmann & Barnard Masonry Stainless Steel HB-200-X Anchor Supporting Brick Veneer – Clear Wall	
Detail 5.1.76	B.5.76
Exterior Insulated 3 5/8" x 1 5/8" Steel Stud (16" o.c.) Wall Assembly with Hohmann & Barnard Masonry Carbon Steel BL-407 Anchor Supporting Brick Veneer – Clear Wall	
Detail 5.1.77	B.5.77
Exterior Insulated 3 5/8" x 1 5/8" Steel Stud (16" o.c.) Wall Assembly with Hohmann & Barnard Masonry Stainless Steel BL-407 Anchor Supporting Brick Veneer – Clear Wall	
Detail 5.1.78	B.5.78
Exterior and Interior Insulated 6" x 1 5/8" Steel Stud (16" o.c. and 24" o.c.) Wall Assembly with Stainless Steel Brick Anchors Supporting Brick Veneer and R-20 Batt Insulation in Stud Cavity – Clear Wall	
Detail 5.1.79	B.5.79
Exterior and Interior Insulated 6" x 1 5/8" Steel Stud (16" o.c. and 24" o.c.) Wall Assembly with Steel Brick Anchors Supporting Brick Veneer and R-20 Batt Insulation in Stud Cavity – Clear Wall	
Detail 5.1.80	B.5.80
Exterior Insulated 6" x 1 5/8" Steel Stud (16" o.c.) Wall Assembly with ECO Cladding Alpha Vci Vertical System – Clear Wall	
Detail 5.1.81	B.5.81
Exterior and Interior Insulated 6" x 1 5/8" Steel Stud (16" o.c.) Wall Assembly with ECO Cladding Alpha Vci Vertical System and R-19 Batt Insulation in Stud Cavity – Clear Wall	
Detail 5.1.82	B.5.82
Exterior Insulated 6" x 1 5/8" Steel Stud (16" o.c.) Wall Assembly with ECO Cladding Alpha Hci Horizontal System – Clear Wall	
Detail 5.1.83	B.5.83
Exterior and Interior Insulated 6" x 1 5/8" Steel Stud (16" o.c.) Wall Assembly with ECO Cladding Alpha Hci Horizontal System and R-19 Batt Insulation in Stud Cavity – Clear Wall	
Detail 5.1.84	B.5.84
Exterior Insulated 3 5/8" x 1 5/8" Steel Stud (16" O.C.) Wall Assembly with Armadillo FRR Horizontal Z-Girts Supporting Cladding – Clear Wall	
Detail 5.1.85	B.5.85
Exterior and Interior Insulated 3 5/8" x 1 5/8" Steel Stud (16" O.C.) Wall Assembly with Armadillo FRR Horizontal Z-Girts Supporting Cladding and R-13 Batt Insulation in Stud Cavity – Clear Wall	
Detail 5.1.86	B.5.86

Exterior Insulated 3 5/8" x 1 5/8" Steel Stud (16" O.C.) Wall Assembly with Armadillo FRR Vertical Z-Girts Supporting Cladding – Clear Wall	
Detail 5.1.87	B.5.87
Exterior and Interior Insulated 3 5/8" x 1 5/8" Steel Stud (16" O.C.) Wall Assembly with Armadillo FRR Vertical Z-Girts Supporting Cladding and R-13 Batt Insulation in Stud Cavity – Clear Wall	
Detail 5.1.88	B.5.88
Exterior Insulated 3 5/8" x 1 5/8" Steel Stud (16" o.c.) Wall Assembly with Brick Ties (24" o.c.) Supporting Brick Veneer – Clear Wall	
Detail 5.1.89	B.5.89
Exterior Insulated 3 5/8" x 1 5/8" Steel Stud (16" o.c.) Wall Assembly with FERO Slotted Rap Ties (24" o.c.) Supporting Brick Veneer – Clear Wall	
Detail 5.1.90	B.5.90
Exterior Insulated 6" x 1 5/8" Steel Stud (16" O.C.) Wall Assembly with Fiber Reinforced Plastic Clip Supporting Cladding – Clear Wall	
Detail 5.1.91	B.5.91
Exterior and Interior Insulated 6" x 1 5/8" Steel Stud (16" O.C.) Wall Assembly with Fiber Reinforced Plastic Clip Supporting Metal Cladding and R-19 Batt in Stud Cavity – Clear Wall	
Detail 5.1.92	B.5.92
Exterior Insulated 6" x 1 5/8" Steel Stud (16" O.C.) Wall Assembly with Double Aluminum Bracket Supporting Metal Cladding	
Detail 5.1.93	B.5.93
Exterior and Interior Insulated 6" x 1 5/8" Steel Stud (16" O.C.) Wall Assembly with Double Aluminum Bracket Supporting Metal Cladding and R-19 Batt Insulation in Stud Cavity	
Detail 5.1.94	B.5.94
Exterior Insulated 6" x 1 5/8" Steel Stud (16" O.C.) Wall Assembly with Technoform Clip and Steel Fasteners - Clear Wall B.5.	
Detail 5.1.95	B.5.95
Exterior Insulated 6" x 1 5/8" Steel Stud (16" O.C.) Wall Assembly with Technoform Clip and Stainless Steel Fasteners - Clear Wall	
Detail 5.1.96	B.5.96
Exterior and Interior Insulated 6" x 1 5/8" Steel Stud (16" o.c.) Wall Assembly with Galvanized Horizontal Intermittent Clips (24" o.c.) Supporting Metal Cladding and Owens Corning R-20 Batt Insulation in Stud Cavity – Clear Wall	
Detail 5.1.97	B.5.97
Exterior and Interior Insulated 6" x 1 5/8" Steel Stud (16" o.c.) Wall Assembly with Galvanized Horizontal Intermittent Clips (24" o.c.) Supporting Metal Cladding and Owens Corning R-22.5 Batt Insulation in Stud Cavity – Clear Wall	
Detail 5.1.98	B.5.98

Exterior and Interior Insulated 6" x 1 5/8" Steel Stud (16" o.c.) Wall Assembly with Galvanized Horizontal Intermittent Clips (24" o.c.) Supporting Metal Cladding and Owens Corning R-24 Batt Insulation in Stud Cavity – Clear Wall	
Detail 5.1.99	B.5.99
Exterior Insulated 6" x 1 5/8" Steel Stud (16" o.c.) Wall Assembly with EJOT Crossfix Console and Horizontal Rail System Supporting Metal Cladding - Clear Wall	
Detail 5.1.100	B.5.100
Exterior and Interior Insulated 6" x 1 5/8" Steel Stud (16" o.c.) Wall Assembly with EJOT Crossfix Console and Horizontal Rail System Supporting Metal Cladding and R-20 Batt Insulation in Stud Cavity - Clear Wall	
Detail 5.1.101	B.5.101
Exterior Insulated 6" x 1 5/8" Steel Stud (24" o.c.) Wall Assembly with EJOT Crossfix Console and Horizontal Rail System Supporting Metal Cladding - Clear Wall	
Detail 5.1.102	B.5.102
Exterior and Interior Insulated 6" x 1 5/8" Steel Stud (24" o.c.) Wall Assembly with EJOT Crossfix Console and Horizontal Rail System Supporting Metal Cladding and R-20 Batt Insulation in Stud Cavity - Clear Wall	
Detail 5.1.103	B.5.103
Exterior Insulated 6" x 1 5/8" Steel Stud (16" o.c.) Wall Assembly with EJOT Crossfix Console and Vertical Rail System Supporting Metal Cladding - Clear Wall	
Detail 5.1.104	B.5.104
Exterior and Interior Insulated 6" x 1 5/8" Steel Stud (16" o.c.) Wall Assembly with EJOT Crossfix Console and Vertical Rail System Supporting Metal Cladding and R-20 Batt Insulation in Stud Cavity - Clear Wall	
Detail 5.1.105	B.5.105
Exterior Insulated 6" x 1 5/8" Steel Stud (24" o.c.) Wall Assembly with EJOT Crossfix Console and Vertical Rail System Supporting Metal Cladding - Clear Wall	
Detail 5.1.106	B.5.106
Exterior and Interior Insulated 6" x 1 5/8" Steel Stud (24" o.c.) Wall Assembly with EJOT Crossfix Console and Vertical Rail System Supporting Metal Cladding and R-20 Batt Insulation in Stud Cavity - Clear Wall	
Detail 5.1.107	B.5.107
Exterior Insulated 6" x 1 5/8" Steel Stud (16" o.c.) Wall Assembly with Horizontal Z-Girts (24" o.c.) Supporting Cladding and Owens Corning ThermaFiber RainBarrier HC Max Insulation – Clear Wall	
Detail 5.1.108	B.5.108
Exterior Insulated 6" x 1 5/8" Steel Stud (16" o.c.) Wall Assembly with High Compression Insulation and Through Insulation Steel Fasteners (12" o.c.) Supporting Cladding, Owens Corning ThermaFiber RainBarrier HC Max Insulation – Clear Wall	

Detail 5.1.109	B.5.109
Exterior Insulated 6" x 1 5/8" Steel Stud (16" o.c.) Wall Assembly with High Compression Insulation and Through Insulation Steel Fasteners (12" o.c.) Supporting Cladding, Owens Corning ThermaFiber RainBarrier Ci HC 80/45 Insulation – Clear Wall	
Detail 5.1.110	B.5.110
Exterior Insulated 6" x 1 5/8" Steel Stud (16" o.c.) Wall Assembly with High Compression Insulation and Through Insulation Stainless Steel Fasteners (12" o.c.) Supporting Cladding, Owens Corning ThermaFiber RainBarrier HC Max Insulation – Clear Wall	
Detail 5.1.111	B.5.111
Exterior Insulated 6" x 1 5/8" Steel Stud (16" o.c.) Wall Assembly with High Compression Insulation and Through Insulation Stainless Steel Fasteners (12" o.c.) Supporting Cladding, Owens Corning ThermaFiber RainBarrier Ci HC 80/45 Insulation – Clear Wall	
Detail 5.1.112	B.5.112
Exterior and Interior Insulated 6" x 1 5/8" Steel Stud (16" o.c.) Wall Assembly with High Compression Insulation and Through Insulation Stainless Steel Fasteners (16" o.c.) Supporting Cladding, Owens Corning ThermaFiber RainBarrier HC Max Insulation and R-20 Batt Insulation in Stud Cavity – Clear Wall	
Detail 5.1.113	B.5.113
Exterior and Interior Insulated 6" x 1 5/8" Steel Stud (16" o.c.) Wall Assembly with High Compression Insulation and Through Insulation Stainless Steel Fasteners (16" o.c.) Supporting Cladding, Owens Corning ThermaFiber RainBarrier Ci HC 80/45 Insulation and R-20 Batt Insulation in Stud Cavity – Clear Wall	
Detail 5.1.114	B.5.114
Exterior and Interior Insulated Wall Assembly with Brick Ties Supporting Brick Veneer and R-12 Batt Insulation in Stud Cavity – Clear Wall	
Detail 5.1.115	B.5.115
Exterior Insulated 6" x 1 5/8" Steel Stud (16" o.c.) Wall Assembly with SOPREMA SOPRA-XPS 20 and ACS-S Thermal Clip Supporting Metal Cladding - Clear Wall	
Detail 5.1.116	B.5.116
Exterior Insulated 6" x 1 5/8" Steel Stud (24" o.c.) Wall Assembly with SOPREMA SOPRA-XPS 20 and ACS-S Thermal Clip Supporting Metal Cladding - Clear Wall	
Detail 5.1.117	B.5.117
Exterior Insulated 6" x 1 5/8" Steel Stud (16" o.c.) Wall Assembly with SOPREMA SOPRA-SPF 202 and ACS-S Thermal Clip Supporting Metal Cladding - Clear Wall	
Detail 5.1.118	B.5.118
Exterior Insulated 6" x 1 5/8" Steel Stud (24" o.c.) Wall Assembly with SOPREMA SOPRA-SPF 202 and ACS-S Thermal Clip Supporting Metal Cladding - Clear Wall	

- Detail 5.1.119**.....**B.5.119**
 Exterior Insulated 6" x 1 5/8" Steel Stud (16" o.c.) Wall Assembly with SOPREMA SOPRA-ISO V ALU and ACS-S Thermal Clip Supporting Metal Cladding - Clear Wall
- Detail 5.1.120**.....**B.5.120**
 Exterior Insulated 6" x 1 5/8" Steel Stud (24" o.c.) Wall Assembly with SOPREMA SOPRA-ISO V ALU and ACS-S Thermal Clip Supporting Metal Cladding - Clear Wall
- Detail 5.1.121**.....**B.5.121**
 Exterior Insulated 6" x 1 5/8" Steel Stud (16" o.c.) Wall Assembly with Mineral Wool and ACS-S Thermal Clip Supporting Metal Cladding - Clear Wall
- Detail 5.1.122**.....**B.5.122**
 Exterior Insulated 6" x 1 5/8" Steel Stud (24" o.c.) Wall Assembly with Mineral Wool and ACS-S Thermal Clip Supporting Metal Cladding - Clear Wall
- Detail 5.1.123**.....**B.5.123**
 Exterior and Interior Insulated 6" x 1 5/8" Steel Stud (16" o.c.) Wall Assembly with SOPREMA SOPRA-XPS 20 and ACS-S Thermal Clip Supporting Metal Cladding with R-20 Cellulose Insulation in Stud Cavity - Clear Wall
- Detail 5.1.124**.....**B.5.124**
 Exterior and Interior Insulated 6" x 1 5/8" Steel Stud (24" o.c.) Wall Assembly with SOPREMA SOPRA-XPS 20 and ACS-S Thermal Clip Supporting Metal Cladding with R-20 Cellulose Insulation in Stud Cavity - Clear Wall
- Detail 5.1.125**.....**B.5.125**
 Exterior and Interior Insulated 6" x 1 5/8" Steel Stud (16" o.c.) Wall Assembly with SOPREMA SOPRA-SPF 202 and ACS-S Thermal Clip Supporting Metal Cladding with R-20 Cellulose Insulation in Stud Cavity - Clear Wall
- Detail 5.1.126**.....**B.5.126**
 Exterior and Interior Insulated 6" x 1 5/8" Steel Stud (24" o.c.) Wall Assembly with SOPREMA SOPRA-SPF 202 and ACS-S Thermal Clip Supporting Metal Cladding with R-20 Cellulose Insulation in Stud Cavity - Clear Wall
- Detail 5.1.127**.....**B.5.127**
 Exterior and Interior Insulated 6" x 1 5/8" Steel Stud (16" o.c.) Wall Assembly with SOPREMA SOPRA-ISO V PLUS and ACS-S Thermal Clip Supporting Metal Cladding with R-20 Cellulose Insulation in Stud Cavity - Clear Wall
- Detail 5.1.128**.....**B.5.128**
 Exterior and Interior Insulated 6" x 1 5/8" Steel Stud (24" o.c.) Wall Assembly with SOPREMA SOPRA-ISO V PLUS and ACS-S Thermal Clip Supporting Metal Cladding with R-20 Cellulose Insulation in Stud Cavity - Clear Wall
- Detail 5.1.129**.....**B.5.129**
 Exterior and Interior Insulated 6" x 1 5/8" Steel Stud (16" o.c.) Wall Assembly with Mineral Wool and ACS-S Thermal Clip Supporting Metal Cladding with R-20 Cellulose Insulation in Stud Cavity - Clear Wall

Detail 5.1.130	B.5.130
Exterior and Interior Insulated 6" x 1 5/8" Steel Stud (24" o.c.) Wall Assembly with Mineral Wool and ACS-S Thermal Clip Supporting Metal Cladding with R-20 Cellulose Insulation in Stud Cavity - Clear Wall	
Detail 5.1.131	B.5.131
Exterior Insulated 6" x 1 5/8" Steel Stud (16" o.c.) Wall Assembly with Protected SOPREMA SOPRA-ISO V ALU and ACS-S Thermal Clip Supporting Metal Cladding - Clear Wall	
Detail 5.1.132	B.5.132
Exterior Insulated 6" x 1 5/8" Steel Stud (24" o.c.) Wall Assembly with Protected SOPREMA SOPRA-ISO V ALU and ACS-S Thermal Clip Supporting Metal Cladding - Clear Wall	
Detail 5.1.133	B.5.133
Exterior and Interior Insulated 6" x 1 5/8" Steel Stud (16" o.c.) Wall Assembly with Protected SOPREMA SOPRA-ISO V PLUS and ACS-S Thermal Clip Supporting Metal Cladding with R-20 Cellulose Insulation in Stud Cavity - Clear Wall	
Detail 5.1.134	B.5.134
Exterior and Interior Insulated 6" x 1 5/8" Steel Stud (24" o.c.) Wall Assembly with Protected SOPREMA SOPRA-ISO V PLUS and ACS-S Thermal Clip Supporting Metal Cladding with R-20 Cellulose Insulation in Stud Cavity - Clear Wall	
Detail 5.1.135	B.5.135
Exterior Insulated 6" x 1 5/8" Steel Stud (16" o.c.) Wall Assembly with U-Kon ND-062 Brackets and Vertical Rail System Supporting Metal Cladding - Clear Wall	
Detail 5.2.1	B.5.136
Exterior Insulated 3 5/8" x 1 5/8" Steel Stud (16" o.c.) Wall Assembly with Horizontal Z-Girts (24" o.c.) Supporting Metal Cladding – Intermediate Floor Intersection	
Detail 5.2.2	B.5.137
Exterior Insulated 3 5/8" x 1 5/8" Steel Stud (16" o.c.) Wall Assembly with Horizontal Z-Girts (24" o.c.) Supporting Metal Cladding – Intermediate Floor Intersection with Top Side Insulation	
Detail 5.2.3	B.5.138
Exterior Insulated 3 5/8" x 1 5/8" Steel Stud (16" o.c.) Wall Assembly with Horizontal Z-Girts (24" o.c.) Supporting Metal Cladding – Intermediate Floor Intersection with Top & Under Side Insulation	
Detail 5.2.4	B.5.139
Exterior Insulated 3 5/8" x 1 5/8" Steel Stud (16" o.c.) Wall Assembly with Horizontal Z-girts (24" o.c.) Supporting Metal Cladding – Uninsulated Intermediate Floor Intersection with Uninsulated Curb	
Detail 5.2.5	B.5.140
Exterior and Interior Insulated 3 5/8" x 1 5/8" Steel Stud (16" o.c.) Wall Assembly with Horizontal Z-girts (24" o.c.) Supporting Metal Cladding and R-12 Batt	

Insulation in Stud Cavity – Uninsulated Intermediate Floor Intersection with Uninsulated Curb

- Detail 5.2.6**.....**B.5.141**
- Exterior Insulated 3 5/8" x 1 5/8" Steel Stud (16" o.c.) Wall Assembly with Horizontal Z-girts (24" o.c.) Supporting Metal Cladding – Uninsulated Intermediate Floor Intersection with Insulated Curb
- Detail 5.2.7**.....**B.5.142**
- Exterior and Interior Insulated 3 5/8" x 1 5/8" Steel Stud (16" o.c.) Wall Assembly with Horizontal Z-girts (24" o.c.) Supporting Metal Cladding and R-12 Batt Insulation in Stud Cavity – Uninsulated Intermediate Floor Intersection with Insulated Curb
- Detail 5.2.8**.....**B.5.143**
- Exterior and Interior Insulated 3 5/8" x 1 5/8" Steel Stud (16" o.c.) Wall Assembly with Vertical Z Girts (16" o.c.) Supporting Stucco Cladding and R-12 Batt Insulation in Stud Cavity – Uninsulated Intermediate Floor Intersection
- Detail 5.2.9**.....**B.5.144**
- Exterior Insulated 3 5/8" x 1 5/8" Steel Stud (16" o.c.) Drained EIFS Wall Assembly – Isokorb CM20 Thermally Broken Slab Projection without Concrete Curb
- Detail 5.2.10**.....**B.5.145**
- Exterior and Interior Insulated 3 5/8" x 1 5/8" Steel Stud (16" o.c.) Drained EIFS Wall Assembly with R-12 Batt Insulation in Stud Cavity – Isokorb CM20 Thermally Broken Slab Projection without Concrete Curb
- Detail 5.2.11**.....**B.5.146**
- Exterior and Interior Insulated 3 5/8" x 1 5/8" Steel Stud (16" o.c.) Wall Assembly with Horizontal Z-girts (24" o.c.) Supporting Metal Cladding and R-12 Batt Insulation in Stud Cavity – Isokorb CM20 Thermally Broken Slab Projection with Uninsulated Curb
- Detail 5.2.12**.....**B.5.147**
- Exterior Insulated 3 5/8" x 1 5/8" Steel Stud (16" o.c.) Wall Assembly with Horizontal Z-girts (24" o.c.) Supporting Metal Cladding – Isokorb CM20 Thermally Broken Slab Projection with Uninsulated Curb
- Detail 5.2.13**.....**B.5.148**
- Exterior Insulated 3 5/8" x 1 5/8" Steel Stud (16" o.c.) Wall Assembly with Horizontal Z-girts (24" o.c.) Supporting Metal Cladding – Isokorb CM20 Thermally Broken Slab Projection with Insulated Curb
- Detail 5.2.14**.....**B.5.149**
- Exterior and Interior Insulated 3 5/8" x 1 5/8" Steel Stud (16" o.c.) Wall Assembly with Horizontal Z-girts (24" o.c.) Supporting Metal Cladding and R-12 Batt Insulation in Stud Cavity – Isokorb CM20 Thermally Broken Slab Projection with Insulated Curb
- Detail 5.2.15**.....**B.5.150**

Exterior Insulated 3 5/8" x 1 5/8" Steel Stud (16" o.c.) Drained EIFS Wall Assembly – Intermediate Floor Intersection	
Detail 5.2.16	B.5.151
Exterior and Interior Insulated 3 5/8" x 1 5/8" Steel Stud (16" o.c.) Drained EIFS Wall Assembly with R-12 Batt Insulation in Stud Cavity – Intermediate Floor Intersection	
Detail 5.2.17	B.5.152
Exterior Insulated 3 5/8" x 1 5/8" Steel Stud (16" o.c.) Wall Assembly with Thermally Broken ISO Clip System Supporting Vertical Sub-girts – Intermediate Concrete Floor Intersection	
Detail 5.2.18	B.5.153
Exterior Insulated 3 5/8" x 1 5/8" Steel Stud (16" o.c.) Wall Assembly with Thermally Broken ISO Clip System Supporting Horizontal Sub-girts – Intermediate Concrete Floor Intersection	
Detail 5.2.19	B.5.154
Exterior and Interior Insulated 3 5/8" x 1 5/8" Steel Stud (16" o.c.) Wall Assembly with Vertical Z-girts (16" o.c.) Supporting Stucco Cladding and R-12 Batt Insulation in Stud Cavity – Steel Framed Floor with Cross Cavity Flashing	
Detail 5.2.20	B.5.155
Exterior Insulated 3 5/8" x 1 5/8" Steel Stud (16" o.c.) Wall Assembly with Fiberglass Spacer and Through Insulation Fasteners Supporting Cladding – Insulated Intermediate Floor Intersection	
Detail 5.2.21	B.5.156
Exterior Insulated 3 5/8" x 1 5/8" Steel Stud (16" o.c.) Wall Assembly with Thermally Isolated Aluminum Clip Horizontal Sub-girt System Supporting Cladding – Intermediate Floor Intersection	
Detail 5.2.22	B.5.157
Exterior Insulated 3 5/8" x 1 5/8" Steel Stud (16" o.c.) Wall Assembly with TAC Fiber Reinforced Plastic Girts Supporting Cladding – Intermediate Floor Intersection	
Detail 5.2.23	B.5.158
Exterior Insulated 3 5/8" x 1 5/8" Steel Stud (16" o.c.) Wall Assembly with Thermally Broken Aluminum Clip Rail System (24" o.c.) Supporting Cladding – Intermediate Floor Intersection	
Detail 5.2.24	B.5.159
Exterior and Interior Insulated 3 5/8" x 1 5/8" Steel Stud (16" o.c.) Wall Assembly with Horizontal Z-Girts (24" o.c.) Supporting Metal Cladding and R-12 Batt Insulation in Stud Cavity – Structural Steel Framed Floor Intersection	
Detail 5.2.25	B.5.160
Interior Insulated 3 5/8" x 1 5/8" Steel Stud (16" o.c.) Wall Assembly with Horizontal Z-Girts (24" o.c.) Supporting Metal Cladding and R-12 Batt Insulation in Stud Cavity – Structural Steel Framed Floor Intersection	

Detail 5.2.26	B.5.161
Exterior and Interior Insulated Wall Assembly with Shelf Angle & Brick Ties Supporting Brick Veneer and R-12 Batt Insulation in Stud Cavity – Intermediate Floor Intersection	
Detail 5.2.27	B.5.162
Exterior and Interior Insulated Wall Assembly with Spaced Shelf Angle & Brick Ties Supporting Brick Veneer and R-12 Batt Insulation in Stud Cavity – Intermediate Floor Intersection	
Detail 5.2.28	B.5.163
Exterior and Interior Insulated Wall Assembly with Stainless Steel Shelf Angle & Brick Ties Supporting Brick Veneer and R-12 Batt Insulation in Stud Cavity – Intermediate Floor Intersection	
Detail 5.2.29	B.5.164
Exterior and Interior Insulated Wall Assembly with Thermally Broken Steel Shelf Angle & Brick Ties Supporting Brick Veneer and R-12 Batt Insulation in Stud Cavity – Slab Intersection	
Detail 5.2.30	B.5.165
Exterior Insulated 3 5/8" x 1 5/8" Steel Stud Wall Assembly with Horizontal Z-girts Supporting Metal Cladding – Armatherm 500 Thermally Broken Slab Projection with Insulated Curb	
Detail 5.2.31	B.5.166
Exterior Insulated 3 5/8" x 1 5/8" Steel Stud Wall Assembly with Armatherm Z-girts Supporting Metal Cladding – Armatherm 500-080 Thermally Broken Slab Projection with Insulated Curb	
Detail 5.2.32	B.5.167
Exterior and Interior Insulated 3 5/8" x 1 5/8" Steel Stud (16" o.c.) Wall Assembly with Nvelope – Eko Thermobacket and NV1 Clip System Supporting Cladding and R-13 Batt Insulation in Stud Cavity – Intermediate Floor Intersection	
Detail 5.2.33	B.5.168
Exterior Insulated 3 5/8" x 1 5/8" Steel Stud (16" o.c.) Wall Assembly with FERO Slotted Rap Ties (24" o.c.) and FERO FAST Thermal Bracket (48" o.c.) Supporting Brick Veneer – Intermediate Floor Intersection	
Detail 5.2.34	B.5.169
Owens Corning Exterior Insulated 6" x 1 5/8" Steel Stud (16" o.c.) Wall Assembly with Thermally Isolated Vertical Brackets and Rail System (24" o.c.) Supporting Metal Cladding – Intermediate Floor Intersection	
Detail 5.2.35	B.5.170
Exterior and Interior Insulated 6" x 1 5/8" Steel Stud (16" o.c.) Wall Assembly with Thermally Isolated Vertical Brackets and Rail System (24" o.c.) Supporting Metal Cladding and Owens Corning R-20 Batt in Stud Cavity – Intermediate Floor Intersection	
Detail 5.2.36	B.5.171

Exterior and Interior Insulated 6" x 1 5/8" Steel Stud (16" o.c.) Wall Assembly with Thermally Isolated Vertical Brackets and Rail System (24" o.c.) Supporting Metal Cladding and Owens Corning R-22.5 Batt in Stud Cavity – Intermediate Floor Intersection	
Detail 5.2.37	B.5.172
Exterior and Interior Insulated 6" x 1 5/8" Steel Stud (16" o.c.) Wall Assembly with Thermally Isolated Vertical Brackets and Rail System (24" o.c.) Supporting Metal Cladding and Owens Corning R-24 Batt in Stud Cavity – Intermediate Floor Intersection	
Detail 5.2.38	B.5.173
Exterior Insulated 6" x 1 5/8" Steel Stud (16" o.c.) Wall Assembly with FRP Vertical Brackets and Rail System Supporting Metal Cladding – Intermediate Floor Intersection	
Detail 5.2.39	B.5.174
Exterior and Interior Insulated 6" x 1 5/8" Steel Stud (16" o.c.) Wall Assembly with FRP Vertical Brackets and Rail System Supporting Metal Cladding and R-19 Batt in Stud Cavity – Intermediate Floor Intersection	
Detail 5.2.40	B.5.175
Exterior Insulated 3 5/8" x 1 5/8" Steel Stud (16" o.c.) Wall Assembly with Horizontal Z-girts (24" o.c.) Supporting Metal Cladding – Isokorb K65-V8 Thermally Broken Slab Projection with Insulated Curb	
Detail 5.2.41	B.5.176
Exterior Insulated 3 5/8" x 1 5/8" Steel Stud (16" o.c.) Wall Assembly with Horizontal Z-girts (24" o.c.) Supporting Metal Cladding – Isokorb K10-V6 Thermally Broken Slab Projection with Insulated Curb	
Detail 5.2.42	B.5.177
Exterior Insulated 3 5/8" x 1 5/8" Steel Stud (16" o.c.) Wall Assembly with Horizontal Z-girts (24" o.c.) Supporting Metal Cladding – Isokorb KXT65-V8 Thermally Broken Slab Projection with Insulated Curb	
Detail 5.2.43	B.5.178
Exterior Insulated 3 5/8" x 1 5/8" Steel Stud (16" o.c.) Wall Assembly with Horizontal Z-girts (24" o.c.) Supporting Metal Cladding – Isokorb KXT15-V6 Thermally Broken Slab Projection with Insulated Curb	
Detail 5.2.44	B.5.179
Exterior and Interior Insulated 3 5/8" x 1 5/8" Steel Stud (16" o.c.) Wall Assembly with Horizontal Z-girts (24" o.c.) Supporting Metal Cladding and R-12 Batt Insulation in Stud Cavity – Isokorb K65-V8 Thermally Broken Slab Projection with Insulated Curb	
Detail 5.2.45	B.5.180
Exterior and Interior Insulated 3 5/8" x 1 5/8" Steel Stud (16" o.c.) Wall Assembly with Horizontal Z-girts (24" o.c.) Supporting Metal Cladding and R-12 Batt Insulation in Stud Cavity – Isokorb K10-V6 Thermally Broken Slab Projection with Insulated Curb	

Detail 5.2.46	B.5.181
Exterior and Interior Insulated 3 5/8" x 1 5/8" Steel Stud (16" o.c.) Wall Assembly with Horizontal Z-girts (24" o.c.) Supporting Metal Cladding and R-12 Batt Insulation in Stud Cavity – Isokorb KXT65-V8 Thermally Broken Slab Projection with Insulated Curb	
Detail 5.2.47	B.5.182
Exterior and Interior Insulated 3 5/8" x 1 5/8" Steel Stud (16" o.c.) Wall Assembly with Horizontal Z-girts (24" o.c.) Supporting Metal Cladding and R-12 Batt Insulation in Stud Cavity – Isokorb KXT15-V6 Thermally Broken Slab Projection with Insulated Curb	
Detail 5.2.48	B.5.183
Exterior and Interior Insulated Wall Assembly with Stainless Steel Spaced Shelf Angle & Brick Ties Supporting Brick Veneer and R-12 Batt Insulation in Stud Cavity – Intermediate Floor Intersection	
Detail 5.2.49	B.5.184
Exterior and Interior Insulated Wall Assembly with Thermally Broken Stainless Steel Shelf Angle & Brick Ties Supporting Brick Veneer and R-12 Batt Insulation in Stud Cavity – Slab Intersection	
Detail 5.2.50	B.5.185
Exterior and Interior Insulated Wall Assembly with Stainless Steel Spaced Shelf Angle Without Flashing & Brick Ties Supporting Brick Veneer – Intermediate Floor Intersection	
Detail 5.2.51	B.5.186
Exterior Insulated 6" x 1 5/8" Steel Stud (16" o.c.) Wall Assembly with U-Kon ND 0-33 Bracket and Vertical Rail System Supporting Metal Cladding – Intermediate Floor Intersection	
Detail 5.3.1	B.5.187
Exterior Insulated 3 5/8" x 1 5/8" Steel Stud (16" o.c.) Drained EIFS Wall Assembly – Window and Intermediate Floor Intersection	
Detail 5.3.2	B.5.188
Exterior and Interior Insulated 3 5/8" x 1 5/8" Steel Stud (16" o.c.) Drained EIFS Wall Assembly with R-12 Batt Insulation in Stud Cavity – Window and Intermediate Floor Intersection	
Detail 5.3.3	B.5.189
Exterior Insulated 3 5/8" x 1 5/8" Steel Stud (16" o.c.) Drained EIFS Wall Assembly – Window with Aerogel and Intermediate Floor Intersection	
Detail 5.3.4	B.5.190
Exterior and Interior Insulated 3 5/8" x 1 5/8" Steel Stud (16" o.c.) Drained EIFS Wall Assembly with R-12 Batt Insulation in Stud Cavity – Window with Aerogel and Intermediate Floor Intersection	
Detail 5.3.5	B.5.191

Exterior Insulated 3 5/8" x 1 5/8" Steel Stud (16" o.c.) Wall Assembly with Horizontal Z-Girts (24" o.c.) Supporting Metal Cladding – Window & Slab Intersection	
Detail 5.3.6	B.5.193
Exterior and Interior Insulated 3 5/8" x 1 5/8" Steel Stud (16" o.c.) Wall Assembly with Horizontal Z-girts (24" o.c.) Supporting Metal Cladding and R-12 Batt Insulation in Stud Cavity – Window and Intermediate Floor Intersection	
Detail 5.3.7	B.5.194
Exterior and Interior Insulated 3 5/8" x 1 5/8" Steel Stud (16" o.c.) Wall Assembly with Vertical Z Girts (16" o.c.) Supporting Stucco Cladding and R-12 Batt Insulation in Stud Cavity – Window and Intermediate Floor Intersection	
Detail 5.3.8	B.5.195
Interior Insulated Steel Frame Wall Assembly with Brick Cladding - Window Intersection	
Detail 5.3.9	B.5.196
Interior Insulated Steel Frame Wall Assembly with Brick Cladding - Window Intersection Aligned with Insulation	
Detail 5.3.10	B.5.197
Exterior Insulated 6" x 1 5/8" Steel Stud (16" o.c.) Wall Assembly with Thermally Isolated Vertical Brackets and Rail System (24" o.c.) Supporting Metal Cladding – Triple Glazed Aluminum Window & Intermediate Floor Intersection with Window Thermal Break Positioned in Steel Framing	
Detail 5.3.11	B.5.198
Exterior and Interior Insulated 6" x 1 5/8" Steel Stud (16" o.c.) Wall Assembly with Thermally Isolated Vertical Brackets and Rail System (24" o.c.) Supporting Metal Cladding and R-19 Batt Insulation in Stud Cavity – Triple Glazed Aluminum Window & Intermediate Floor Intersection with Window Thermal Break Positioned in Steel Framing	
Detail 5.3.12	B.5.199
Exterior Insulated 6" x 1 5/8" Steel Stud (16" o.c.) Wall Assembly with Thermally Isolated Vertical Brackets and Rail System (24" o.c.) Supporting Metal Cladding – Triple Glazed Aluminum Curtain Wall & Intermediate Floor Intersection with Window Thermal Break Positioned in the Exterior Insulation	
Detail 5.3.13	B.5.200
Exterior and Interior Insulated 6" x 1 5/8" Steel Stud (16" o.c.) Wall Assembly with Thermally Isolated Vertical Brackets and Rail System (24" o.c.) Supporting Metal Cladding and R-19 Batt Insulation in Stud Cavity – Triple Glazed Aluminum Curtain Wall & Intermediate Floor Intersection with Window Thermal Break Positioned in the Exterior Insulation	
Detail 5.3.14	B.5.201
Owens Corning Exterior Insulated 6" x 1 5/8" Steel Stud (16" o.c.) Wall Assembly with Thermally Isolated Vertical Brackets and Rail System (24" o.c.) Supporting	

Metal Cladding – Double Glazed Aluminum Window and Intermediate Floor Intersection

Detail 5.3.15.....B.5.202

Exterior and Interior Insulated 6" x 1 5/8" Steel Stud (16" o.c.) Wall Assembly with Thermally Isolated Vertical Brackets and Rail System (24" o.c.) Supporting Metal Cladding and Owens Corning R-20 Batt in Stud Cavity – Double Glazed Aluminum Window and Intermediate Floor Intersection

Detail 5.3.16.....B.5.203

Exterior and Interior Insulated 6" x 1 5/8" Steel Stud (16" o.c.) Wall Assembly with Thermally Isolated Vertical Brackets and Rail System (24" o.c.) Supporting Metal Cladding and Owens Corning R-22.5 Batt in Stud Cavity – Double Glazed Aluminum Window and Intermediate Floor Intersection

Detail 5.3.17.....B.5.204

Owens Corning Exterior Insulated 6" x 1 5/8" Steel Stud (16" o.c.) Wall Assembly with Thermally Isolated Vertical Brackets and Rail System (24" o.c.) Supporting Metal Cladding – Triple Glazed Aluminum Window and Intermediate Floor Intersection

Detail 5.3.18.....B.5.205

Exterior and Interior Insulated 6" x 1 5/8" Steel Stud (16" o.c.) Wall Assembly with Thermally Isolated Vertical Brackets and Rail System (24" o.c.) Supporting Metal Cladding and Owens Corning R-20 Batt in Stud Cavity – Triple Glazed Aluminum Window and Intermediate Floor Intersection

Detail 5.3.19.....B.5.206

Exterior and Interior Insulated 6" x 1 5/8" Steel Stud (16" o.c.) Wall Assembly with Thermally Isolated Vertical Brackets and Rail System (24" o.c.) Supporting Metal Cladding and Owens Corning R-22.5 Batt in Stud Cavity – Triple Glazed Aluminum Window and Intermediate Floor Intersection

Detail 5.3.20.....B.5.207

Exterior Insulated 6" x 1 5/8" Steel Stud (16" o.c.) Wall Assembly with FRP and Thermally Broken Vertical Brackets and Rail System Supporting Metal Cladding – Triple Glazed Vinyl Window and Intermediate Floor Intersection

Detail 5.3.21.....B.5.208

Exterior Insulated 6" x 1 5/8" Steel Stud (16" o.c.) Wall Assembly with FRP and Thermally Broken Vertical Brackets and Rail System Supporting Metal Cladding with Aerogel Insulation Blanket – Triple Glazed Vinyl Window and Intermediate Floor Intersection

Detail 5.3.22.....B.5.209

Exterior and Interior Insulated 6" x 1 5/8" Steel Stud (16" o.c.) Wall Assembly with FRP and Thermally Broken Vertical Brackets and Rail System Supporting Metal Cladding and R-19 Batt in Stud Cavity – Triple Glazed Vinyl Window and Intermediate Floor Intersection

Detail 5.3.23.....B.5.210

Exterior and Interior Insulated 6" x 1 5/8" Steel Stud (16" o.c.) Wall Assembly with FRP and Thermally Broken Vertical Brackets and Rail System Supporting Metal Cladding with Aerogel Insulation Blanket and R-19 Batt in Stud Cavity– Triple Glazed Vinyl Window and Intermediate Floor Intersection	
Detail 5.4.1	B.5.211
Exterior Insulated 3 5/8" x 1 5/8" Steel Stud (16" o.c.) Drained EIFS Wall Assembly – Conventional Curtain Wall Transition	
Detail 5.4.2	B.5.212
Exterior and Interior Insulated 3 5/8" x 1 5/8" Steel Stud (16" o.c.) Drained EIFS Wall Assembly with R-12 Batt Insulation in Stud Cavity – Conventional Curtain Wall Transition	
Detail 5.4.3	B.5.213
Exterior and Interior Insulated 3 5/8" x 1 5/8" Steel Stud (16" o.c.) Wall Assembly with R-12 Batt Insulation in Stud Cavity – Curtain Wall Transition	
Detail 5.4.4	B.5.214
Exterior and Interior Insulated 3 5/8" x 1 5/8" Steel Stud (16" o.c.) Wall Assembly with Horizontal Z-Girts (24" o.c.) Supporting Metal Cladding and R-12 Batt Insulation in Stud Cavity – Conventional Curtain Wall Intersection	
Detail 5.4.5	B.5.215
Exterior Insulated Concrete Wall and Steel Stud Assembly Supporting Metal Cladding– Curtain Wall Transition Intersection	
Detail 5.4.6	B.5.216
Exterior Insulated Concrete Wall and Steel Stud Assembly Supporting Metal Cladding with Cavity Insulation– Curtain Wall Transition Intersection	
Detail 5.5.1	B.5.217
Exterior Insulated 3 5/8" x 1 5/8" Steel Stud (16" o.c.) Drained EIFS Wall Assembly – Concrete Parapet & Slab Intersection	
Detail 5.5.2	B.5.218
Exterior Insulated 3 5/8" x 1 5/8" Steel Stud (16" o.c.) Drained EIFS Wall Assembly – Insulated Concrete Parapet & Slab Intersection	
Detail 5.5.3	B.5.219
Exterior and Interior Insulated 3 5/8" x 1 5/8" Steel Stud (16" o.c.) Drained EIFS Wall Assembly with R-12 Batt Insulation in Stud Cavity – Concrete Parapet & Slab Intersection	
Detail 5.5.4	B.5.220
Exterior and Interior Insulated 3 5/8" x 1 5/8" Steel Stud (16" o.c.) Drained EIFS Wall Assembly with R-12 Batt Insulation in Stud Cavity – Insulated Concrete Parapet & Slab Intersection	
Detail 5.5.5	B.5.221

Exterior Insulated 3 5/8" x 1 5/8" Steel Stud (16" O.C.) Wall Assembly with Horizontal Z-Girts (24" O.C.) Supporting Metal Cladding – Concrete Parapet & Slab Intersection	
Detail 5.5.6	B.5.222
Exterior and Interior Insulated 3 5/8" x 1 5/8" Steel Stud (16" o.c.) Wall Assembly with Horizontal Z-girts (24" o.c.) Supporting Metal Cladding and R-12 Batt Insulation in Stud Cavity – Concrete Parapet and Slab Intersection	
Detail 5.5.7	B.5.223
Exterior and Interior Insulated 3 5/8" x 1 5/8" Steel Stud (16" o.c.) Wall Assembly with Vertical Z Girts (16" o.c.) Supporting Stucco Cladding and R-12 Batt Insulation in Stud Cavity – Concrete Parapet & Slab Intersection	
Detail 5.5.8	B.5.224
Exterior and Interior Insulated 3 5/8" x 1 5/8" Steel Stud (16" o.c.) Wall Assembly with Intermittent Vertical Z Girts (16" o.c.) Supporting Metal Cladding and R-12 Batt Insulation in Stud Cavity –Concrete Roof Deck at Continuous Concrete Parapet	
Detail 5.5.9	B.5.225
Exterior and Interior Insulated 3 5/8" x 1 5/8" Steel Stud (16" o.c.) Wall Assembly with Intermittent Vertical Z Girts (16" o.c.) Supporting Metal Cladding and R-12 Batt Insulation in Stud Cavity – Concrete Roof Deck at Isokorb AXT1 Thermally Broken Concrete Parapet	
Detail 5.5.10	B.5.226
Exterior and Interior Insulated 3 5/8" x 1 5/8" Steel Stud (16" o.c.) Wall Assembly with Horizontal Z-Girts (24" o.c.) Supporting Metal Cladding and R-12 Batt Insulation in Stud Cavity – Steel Roof Deck with Open Web Steel Joist & Parapet Intersection	
Detail 5.5.11	B.5.227
Exterior and Interior Insulated 3 5/8" x 1 5/8" Steel Stud (16" o.c.) Wall Assembly with Horizontal Z-Girts (24" o.c.) Supporting Metal Cladding and R-12 Batt Insulation in Stud Cavity – Steel Roof Deck with Open Web Steel Joist & Parapet Intersection with Thermal Break under Parapet Stud Cavity	
Detail 5.5.12	B.5.228
Owens Corning Exterior Insulated 6" x 1 5/8" Steel Stud (16" o.c.) Wall Assembly with Thermally Isolated Vertical Brackets and Rail System (24" o.c.) Supporting Metal Cladding – Concrete Parapet and Roof Intersection	
Detail 5.5.13	B.5.229
Exterior and Interior Insulated 6" x 1 5/8" Steel Stud (16" o.c.) Wall Assembly with Thermally Isolated Vertical Brackets and Rail System (24" o.c.) Supporting Metal Cladding and Owens Corning R-20 Batt in Stud Cavity – Concrete Parapet and Roof Intersection	
Detail 5.5.14	B.5.230
Exterior and Interior Insulated 6" x 1 5/8" Steel Stud (16" o.c.) Wall Assembly with Thermally Isolated Vertical Brackets and Rail System (24" o.c.) Supporting Metal	

Cladding and Owens Corning R-22.5 Batt in Stud Cavity – Concrete Parapet and Roof Intersection

Detail 5.5.15.....B.5.231

Exterior and Interior Insulated 6" x 1 5/8" Steel Stud (16" o.c.) Wall Assembly with Thermally Isolated Vertical Brackets and Rail System (24" o.c.) Supporting Metal Cladding and Owens Corning R-24 Batt in Stud Cavity – Concrete Parapet and Roof Intersection

Detail 5.5.16.....B.5.232

Owens Corning Exterior Insulated 6" x 1 5/8" Steel Stud (16" o.c.) Wall Assembly with Thermally Isolated Vertical Brackets and Rail System (24" o.c.) Supporting Metal Cladding – Concrete Roof Deck at Isokorb AXTI Thermal Broken Concrete Parapet

Detail 5.5.17.....B.5.233

Exterior and Interior Insulated 6" x 1 5/8" Steel Stud (16" o.c.) Wall Assembly with Thermally Isolated Vertical Brackets and Rail System (24" o.c.) Supporting Metal Cladding and Owens Corning R-20 Batt in Stud Cavity – Concrete Roof Deck at Isokorb AXTI Thermal Broken Concrete Parapet

Detail 5.5.18.....B.5.234

Exterior and Interior Insulated 6" x 1 5/8" Steel Stud (16" o.c.) Wall Assembly with Thermally Isolated Vertical Brackets and Rail System (24" o.c.) Supporting Metal Cladding and Owens Corning R-22.5 Batt in Stud Cavity – Concrete Roof Deck at Isokorb AXTI Thermal Broken Concrete Parapet

Detail 5.5.19.....B.5.235

Exterior and Interior Insulated 6" x 1 5/8" Steel Stud (16" o.c.) Wall Assembly with Thermally Isolated Vertical Brackets and Rail System (24" o.c.) Supporting Metal Cladding and Owens Corning R-24 Batt in Stud Cavity – Concrete Roof Deck at Isokorb AXTI Thermal Broken Concrete Parapet

Detail 5.5.20.....B.5.236

Exterior Insulated 6" x 1 5/8" Steel Stud (16" o.c.) Wall Assembly with Thermally Isolated Vertical Brackets and Rail System Supporting Metal Cladding – Concrete Roof Deck at Isokorb AXT Thermally Broken Concrete Parapet

Detail 5.5.21.....B.5.237

Exterior and Interior Insulated 6" x 1 5/8" Steel Stud (16" o.c.) Wall Assembly with Thermally Isolated Vertical Brackets and Rail System Supporting Metal Cladding and R-19 Batt in Stud Cavity – Concrete Roof Deck at Isokorb AXT Thermally Broken Concrete Parapet

Detail 5.5.22.....B.5.238

Exterior Insulated 6" x 1 5/8" Steel Stud (16" o.c.) Wall Assembly with Thermally Isolated Vertical Brackets and Rail System (24" o.c.) Supporting Metal Cladding – Concrete Parapet and Roof Intersection

Detail 5.5.23.....B.5.239

Exterior and Interior Insulated 6" x 1 5/8" Steel Stud (16" o.c.) Wall Assembly with Thermally Isolated Vertical Brackets and Rail System (24" o.c.) Supporting Metal Cladding and R-20 Batt in Stud Cavity – Concrete Parapet and Roof Intersection	
Detail 5.5.24	B.5.240
Exterior Insulated 6" x 1 5/8" Steel Stud (16" o.c.) Wall Assembly with Thermally Isolated Vertical Brackets and Rail System (24" o.c.) Supporting Metal Cladding – Concrete Roof Deck at Isokorb AXTI Thermal Broken Concrete Parapet	
Detail 5.5.25	B.5.241
Exterior and Interior Insulated 6" x 1 5/8" Steel Stud (16" o.c.) Wall Assembly with Thermally Isolated Vertical Brackets and Rail System (24" o.c.) Supporting Metal Cladding and R-20 Batt in Stud Cavity – Concrete Roof Deck at Isokorb AXTI Thermal Broken Concrete Parapet	
Detail 5.6.1	B.5.242
Exterior Insulated 3 5/8" x 1 5/8" Steel Stud (16" o.c.) Drained EIFS Wall Assembly – Corner Intersection	
Detail 5.6.2	B.5.243
Exterior and Interior Insulated 3 5/8" x 1 5/8" Steel Stud (16" o.c.) Drained EIFS Wall Assembly with R-12 Batt Insulation in Stud Cavity – Corner Intersection	
Detail 5.6.3	B.5.244
Exterior Insulated 3 5/8" x 1 5/8" Steel Stud (16" O.C.) Wall Assembly with Horizontal Z-Girts (24" O.C.) Supporting Metal Cladding – Corner Intersection	
Detail 5.6.4	B.5.245
Exterior Insulated 3 5/8" x 1 5/8" Steel Stud (16" O.C.) Wall Assembly with Horizontal Z-Girts (24" O.C.) Supporting Metal Cladding – Corner Intersection with Alternative Framing	
Detail 5.6.5	B.5.246
Exterior and Interior Insulated 3 5/8" x 1 5/8" Steel Stud (16" o.c.) Wall Assembly with Horizontal Z-girts (24" o.c.) Supporting Metal Cladding and R-12 Batt Insulation in Stud Cavity – Corner Intersection	
Detail 5.6.6	B.5.247
Window Wall System – Transition to Exterior Insulated Steel Stud Wall Assembly with Horizontal Z-girts (24" o.c.) Supporting Metal Cladding & No Interior Stud Cavity Insulation	
Detail 5.6.7	B.5.248
Window Wall System – Transition to Exterior Insulated Steel Stud Wall Assembly with Horizontal Z-girts (24" o.c.) Supporting Metal Cladding & Interior Sprayfoam and Fibreglass Batt Insulation	
Detail 5.7.1	B.5.250
Exterior and Interior Insulated 3 5/8" x 1 5/8" Steel Stud (16" o.c.) Wall Assembly with Horizontal Z-Girts (24" o.c.) Supporting Metal Cladding and R-12 Batt Insulation in Stud Cavity – Structural Steel Column & Cantilever Beam Intersection (Canopy Support)	

Detail 5.7.2	B.5.251
Exterior and Interior Insulated 3 5/8" x 1 5/8" Steel Stud (16" o.c.) Wall Assembly with Horizontal Z-girts (24" o.c.) Supporting Metal Cladding and R-12 Batt Insulation in Stud Cavity – Structural Steel Floor Intersection with Uninterrupted Beam	
Detail 5.7.3	B.5.252
Exterior and Interior Insulated 3 5/8" x 1 5/8" Steel Stud (16" o.c.) Wall Assembly with Horizontal Z-girts (24" o.c.) Supporting Metal Cladding and R-12 Batt Insulation in Stud Cavity – Structural Steel Floor Intersection with Isolator Pad	
Detail 5.7.4	B.5.253
Exterior and Interior Insulated 3 5/8" x 1 5/8" Steel Stud (16" o.c.) Wall Assembly with Horizontal Z-girts (24" o.c.) Supporting Metal Cladding and R-12 Batt Insulation in Stud Cavity – Structural Steel Floor Intersection with Isokorb S22 Thermally Broken Beam	
Detail 5.7.5	B.5.254
Exterior Insulated 3 5/8" x 1 5/8" Steel Stud (16" o.c.) Wall Assembly with Intermittent Vertical Z-girts (16" o.c.) Supporting Metal Cladding – Concrete Floor to Steel Beam Connection	
Detail 5.7.6	B.5.255
Exterior Insulated 3 5/8" x 1 5/8" Steel Stud (16" o.c.) Wall Assembly with Intermittent Vertical Z-girts (16" o.c.) Supporting Metal Cladding – Concrete Floor to Steel Beam with a Thermal Isolator Pad Connection	
Detail 5.7.7	B.5.256
Exterior Insulated 3 5/8" x 1 5/8" Steel Stud (16" o.c.) Wall Assembly with Intermittent Vertical Z-girts (16" o.c.) Supporting Metal Cladding – Concrete Floor to Steel Beam with Isokorb KS14 Connection	
Detail 5.7.8	B.5.257
Exterior and Interior Insulated 3 5/8" x 1 5/8" Steel Stud (16" o.c.) Wall Assembly with Horizontal Z-girts (24" o.c.) Supporting Metal Cladding and R-12 Batt Insulation in Stud Cavity – Structural Steel Floor Intersection with Beam Thermal Break	
Detail 5.7.9	B.5.258
Exterior and Interior Insulated 3 5/8" x 1 5/8" Steel Stud (16" o.c.) Wall Assembly with Horizontal Z-girts (24" o.c.) Supporting Metal Cladding and R-12 Batt Insulation in Stud Cavity – Structural Steel Floor Intersection with Aerolon Coating	
Detail 5.7.10	B.5.259
Exterior Insulated 6" x 1 5/8" Steel Stud (16" o.c.) Wall Assembly with FRP Vertical Brackets and Rail System Supporting Metal Cladding – Structural Steel Column & Knife Edge Cable Support Intersection	
Detail 5.7.11	B.5.260

Exterior and Interior Insulated 6" x 1 5/8" Steel Stud (16" o.c.) Wall Assembly with FRP Vertical Brackets and Rail System Supporting Metal Cladding with R-19 Batt in Stud Cavity – Structural Steel Column & Knife Edge Cable Support Intersection	
Detail 5.7.12	B.5.261
Exterior and Interior Insulated 3 5/8" x 1 5/8" Steel Stud (16" o.c.) Wall Assembly with Horizontal Z-girts (24" o.c.) Supporting Metal Cladding and R-12 Batt Insulation in Stud Cavity – Structural Steel Floor Intersection with Thermal Isolator Pad	
Detail 5.7.13	B.5.262
Exterior and Interior Insulated 3 5/8" x 1 5/8" Steel Stud (16" o.c.) Wall Assembly with Horizontal Z-girts (24" o.c.) Supporting Metal Cladding and R-12 Batt Insulation in Stud Cavity – Structural Steel Floor Intersection with Isokorb KST System Thermally Broken Beam	
Detail 5.8.1	B.5.263
Exterior and Interior Insulated 3 5/8" x 1 5/8" Steel Stud (16" o.c.) Wall Assembly with Horizontal Z-Girts (24" o.c.) Supporting Metal Cladding and R-12 Batt Insulation in Stud Cavity – Interior Wall Intersection	
Detail 5.8.2	B.5.264
Exterior Insulated 6" x 1 5/8" Steel Stud (16" o.c.) Wall Assembly with FRP Vertical Brackets and Rail System Supporting Metal Cladding – At-Grade Foundation Wall Intersection	
Detail 5.8.3	B.5.265
Exterior and Interior Insulated 6" x 1 5/8" Steel Stud (16" o.c.) Wall Assembly with FRP Vertical Brackets and Rail System Supporting Metal Cladding and R19 Batt Insulation in Stud Cavity – At-Grade Foundation Wall Intersection	

Detail 5.1.1

Interior Insulated 3 5/8" x 1 5/8" Steel Stud Wall Assembly – Clear Wall

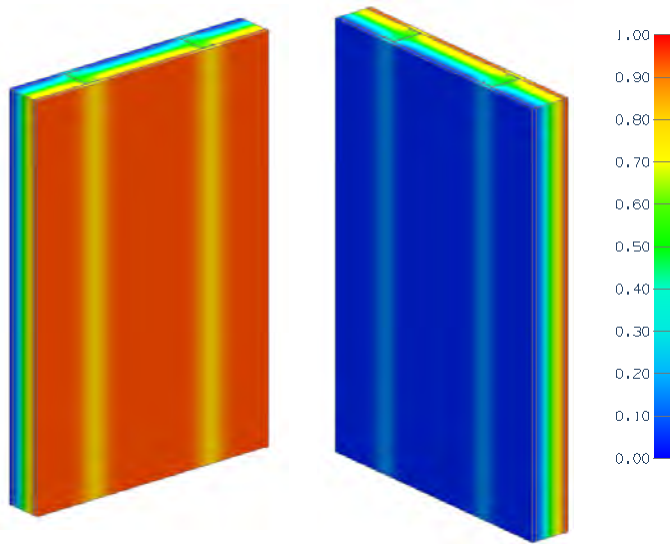

Thermal Performance Indicators

Assembly 1D (Nominal) R-Value	R_{1D}	R-2.3 (0.40 RSI) + interior insulation or R-0.9 (0.16 RSI) for air in stud cavity
Transmittance / Resistance	U_o, R_o	“clear wall” U- and R-value

View from Interior

View from Exterior

Nominal (1D) vs. Assembly Performance Indicators

Stud Spacing	Stud Cavity Insulation	R_{1D} ft ² ·hr·°F / Btu (m ² K / W)	R_o ft ² ·hr·°F / Btu (m ² K / W)	U_o Btu/ft ² ·hr ·°F (W/m ² K)
16" o.c.	Air	R-3.2 (0.56)	R-3.1 (0.55)	0.321 (1.82)
	R-12 (2.11 RSI) Batt	R-14.3 (2.51)	R-9.2 (1.61)	0.109 (0.62)
	R-13 (2.29 RSI) Batt	R-15.3 (2.69)	R-9.5 (1.68)	0.105 (0.60)
24" o.c.	Air	R-3.2 (0.56)	R-3.1 (0.55)	0.318 (1.81)
	R-12 (2.11 RSI) Batt	R-14.3 (2.51)	R-10.4 (1.83)	0.096 (0.55)
	R-13 (2.29 RSI) Batt	R-15.3 (2.69)	R-10.9 (1.92)	0.092 (0.52)

Detail 5.1.2

Interior Insulated 6" x 1 5/8" Steel Stud Wall Assembly – Clear Wall

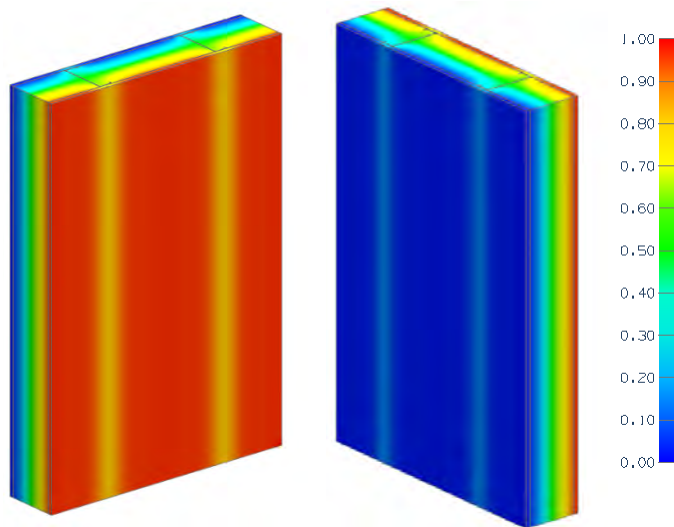

View from Interior

View from Exterior

Thermal Performance Indicators

Assembly 1D (Nominal) R-Value	R_{1D}	R-2.3 (0.40 RSI) + interior insulation or R-0.9 (0.16 RSI) for air in stud cavity
Transmittance / Resistance	U_o , R_o	“clear wall” U- and R-value

Nominal (1D) vs. Assembly Performance Indicators

Stud Spacing	Stud Cavity Insulation	R_{1D} ft ² ·hr·°F / Btu (m ² K / W)	R_o ft ² ·hr·°F / Btu (m ² K / W)	U_o Btu/ft ² ·hr·°F (W/m ² K)
16" o.c.	Air	R-3.2 (0.56)	R-3.1 (0.55)	0.320 (1.82)
	R-19 (3.35 RSI) Batt	R-21.3 (3.75)	R-11.4 (2.01)	0.088 (0.50)
	R-20 (3.52 RSI) Batt	R-22.3 (3.92)	R-11.6 (2.05)	0.086 (0.49)
	R-22 (3.87 RSI) Batt	R-24.3 (4.27)	R-12.1 (2.14)	0.082 (0.47)
	R-24 (4.22 RSI) Batt	R-26.3 (4.63)	R-12.6 (2.22)	0.079 (0.45)
24" o.c.	Air	R-3.2 (0.56)	R-3.1 (0.56)	0.318 (1.80)
	R-19 (3.35 RSI) Batt	R-21.3 (3.75)	R-13.5 (2.37)	0.074 (0.42)
	R-20 (3.52 RSI) Batt	R-22.3 (3.92)	R-13.8 (2.44)	0.072 (0.41)
	R-22 (3.87 RSI) Batt	R-24.3 (4.27)	R-14.5 (2.56)	0.069 (0.39)
	R-24 (4.22 RSI) Batt	R-26.3 (4.63)	R-15.2 (2.68)	0.066 (0.37)

Detail 5.1.3

Exterior Insulated 3 5/8" x 1 5/8" Steel Stud (16" o.c.) Drained EIFS Wall Assembly – Clear Wall

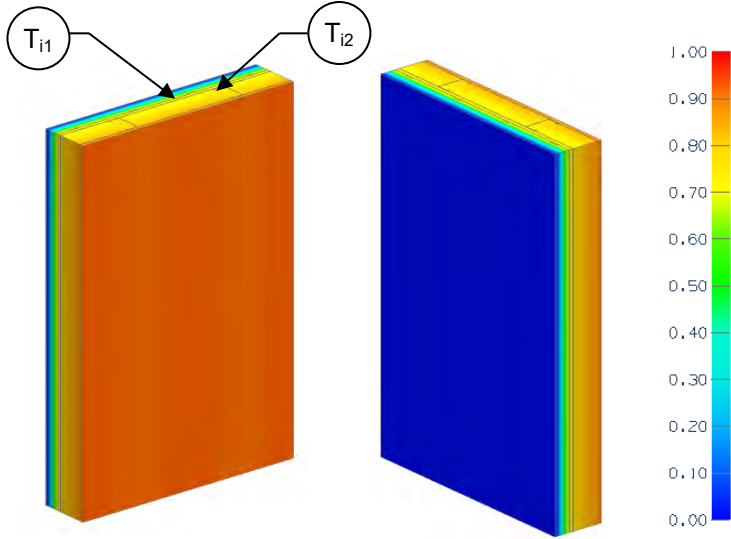

Thermal Performance Indicators

Assembly 1D (Nominal) R-Value	R_{1D}	R-2.7 (0.47 RSI) + exterior insulation
Transmittance / Resistance	U_o, R_o	“clear wall” U- and R-value
Surface Temperature Index ¹	T_i	0 = exterior temperature 1 = interior temperature

¹Assumptions and limitations for surface temperatures identified in ASHRAE 1365-RP

View from Interior

View from Exterior

Nominal (1D) vs. Assembly Performance Indicators

Exterior Insulation 1D R-Value (RSI)	R_{1D} ft ² ·hr·°F / Btu (m ² K / W)	R_o ft ² ·hr·°F / Btu (m ² K / W)	U_o Btu/ft ² ·hr ·°F (W/m ² K)
R-7.5 (1.32)	R-10.2 (1.80)	R-10.0 (1.76)	0.100 (0.57)
R-11.3 (1.98)	R-13.9 (2.46)	R-13.7 (2.41)	0.073 (0.41)
R-15 (2.64)	R-17.7 (3.12)	R-17.4 (3.06)	0.057 (0.33)

Temperature Indices

	R7.5	R11.3	R15	
T_{i1}	0.80	0.85	0.88	Min T on sheathing, between studs
T_{i2}	0.82	0.86	0.89	Max T on sheathing, along studs

Detail 5.1.4

Exterior and Interior Insulated 3 5/8" x 1 5/8" Steel Stud (16" o.c.) Drained EIFS Wall Assembly with R-12 Batt Insulation in Stud Cavity – Clear Wall

Thermal Performance Indicators

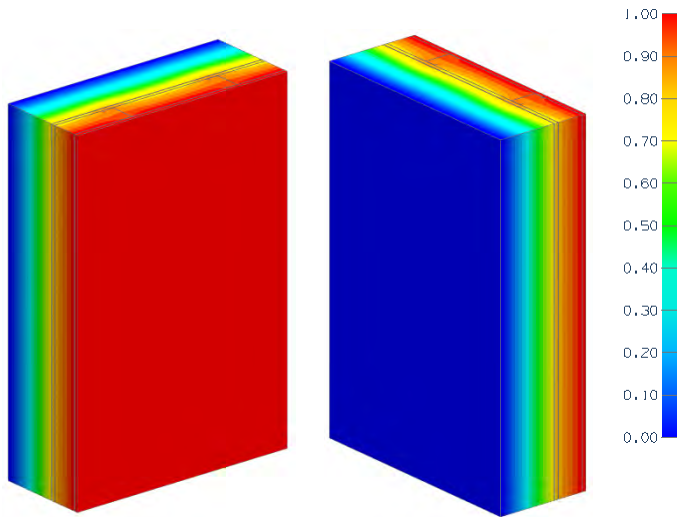

View from Interior

View from Exterior

Assembly 1D (Nominal) R-Value	R_{1D}	R-13.8 (2.43 RSI) + exterior insulation
Transmittance / Resistance	U_o , R_o	“clear wall” U- and R-value

Nominal (1D) vs. Assembly Performance Indicators

Exterior Insulation 1D R-Value (RSI)	R_{1D} ft ² ·hr·°F / Btu (m ² K / W)	R_o ft ² ·hr·°F / Btu (m ² K / W)	U_o Btu/ft ² ·hr ·°F (W/m ² K)
R-7.5 (1.32)	R-21.3 (3.75)	R-16.6 (2.92)	0.060 (0.34)
R-11.3 (1.98)	R-25.0 (4.41)	R-20.3 (3.57)	0.049 (0.28)
R-15.0 (2.64)	R-28.8 (5.07)	R-24.0 (4.23)	0.042 (0.24)
R-18.8 (3.30)	R-32.5 (5.73)	R-27.8 (4.89)	0.036 (0.20)
R-22.5 (3.96)	R-36.3 (6.39)	R-31.5 (5.55)	0.032 (0.18)

Detail 5.1.5

Exterior Insulated 3 5/8" x 1 5/8" Steel Stud (16" o.c.) Wall Assembly with Vertical Z-Girts (16" o.c.) Supporting Metal Cladding – Clear Wall

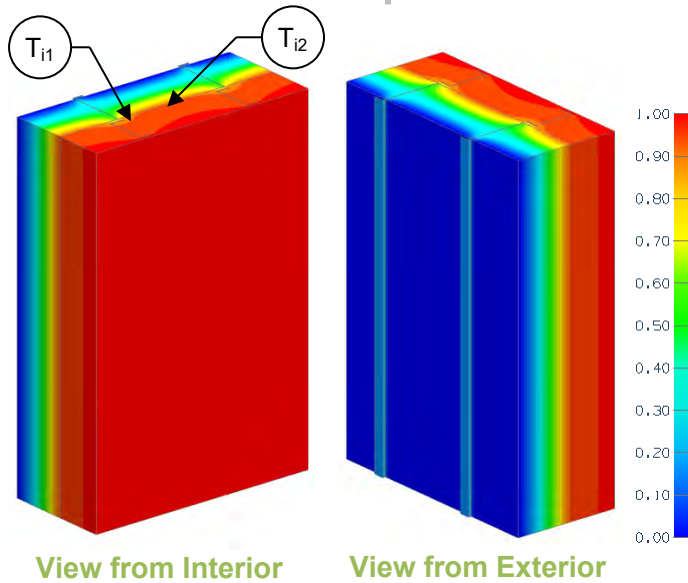

Thermal Performance Indicators

Assembly 1D (Nominal) R-Value	R_{1D}	R-3.2 (0.56) + insulation
Transmittance / Resistance without Anomaly	U_o , R_o	"clear field" U- and R-value, without connectors or joint
Surface Temperature Index ¹	T_i	0 = exterior temperature 1 = interior temperature

Nominal (1D) vs. Assembly Performance Indicators

Exterior Insulation 1D R-Value (RSI)	R_{1D} ft ² ·hr·°F / Btu (m ² K / W)	R_o ft ² ·hr·°F / Btu (m ² K / W)	U_o Btu/ft ² ·hr ·°F (W/m ² K)
R-5.0 (0.88)	R-8.2 (1.44)	R-6.4 (1.12)	0.157 (0.89)
R-10.0 (1.76)	R-13.2 (2.32)	R-8.3 (1.47)	0.120 (0.68)
R-15.0 (2.64)	R-18.2 (3.20)	R-9.7 (1.70)	0.103 (0.59)
R-20.0 (3.52)	R-23.2 (4.08)	R-10.8 (1.91)	0.092 (0.52)
R-25.0 (4.40)	R-28.2 (4.96)	R-11.8 (2.08)	0.085 (0.48)
R-30.0 (5.28)	R-33.2 (5.85)	R-12.7 (2.23)	0.079 (0.45)
R-35.0 (6.16)	R-38.2 (6.73)	R-13.5 (2.38)	0.074 (0.42)
R-40.0 (7.04)	R-43.2 (7.61)	R-14.3 (2.52)	0.070 (0.40)

Temperature Indices

	R5	R10	R15	R20	R25	R30	R35	R40	
T_{i1}	0.63	0.69	0.72	0.75	0.77	0.78	0.79	0.80	Min T on sheathing, along girts at stud intersection
T_{i2}	0.72	0.80	0.84	0.84	0.86	0.87	0.88	0.89	Max T on sheathing, centre of stud cavity

Detail 5.1.6

Exterior and Interior Insulated 6" x 1 5/8" Steel Stud (16" o.c.) Wall Assembly with Vertical Z-Girts (16" o.c.) Supporting Metal Cladding and R-20 Batt Insulation in Stud Cavity – Clear Wall

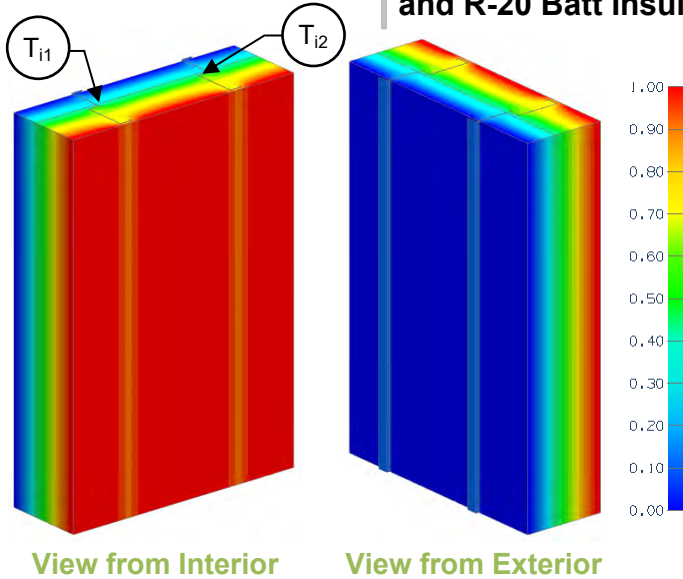

Thermal Performance Indicators

Assembly 1D (Nominal) R-Value	R_{1D}	R-22.3 (3.93) + insulation
Transmittance / Resistance without Anomaly	U_o , R_o	"clear field" U- and R-value, without connectors or joint
Surface Temperature Index ¹	T_i	0 = exterior temperature 1 = interior temperature

Nominal (1D) vs. Assembly Performance Indicators

Exterior Insulation 1D R-Value (RSI)	R_{1D} ft ² ·hr·°F / Btu (m ² K / W)	R_o ft ² ·hr·°F / Btu (m ² K / W)	U_o Btu/ft ² ·hr ·°F (W/m ² K)
R-20.0 (3.52)	R-42.3 (7.45)	R-17.6 (3.11)	0.057 (0.32)
R-25.0 (4.40)	R-47.3 (8.33)	R-18.6 (3.27)	0.054 (0.31)
R-30.0 (5.28)	R-52.3 (9.21)	R-19.4 (3.42)	0.052 (0.29)

Temperature Indices

	R20	R25	R30	
T_{i1}	0.45	0.48	0.50	Min T on sheathing, beside studs
T_{i2}	0.52	0.54	0.56	Max T on sheathing, behind girts at stud intersection

Detail 5.1.7

Exterior and Interior Insulated 6" x 1 5/8" Steel Stud (16" o.c.) Wall Assembly with Vertical Z-Girts (16" o.c.) and 1 1/2" Spray Foam (R-9.8) in Stud Cavity – Clear Wall

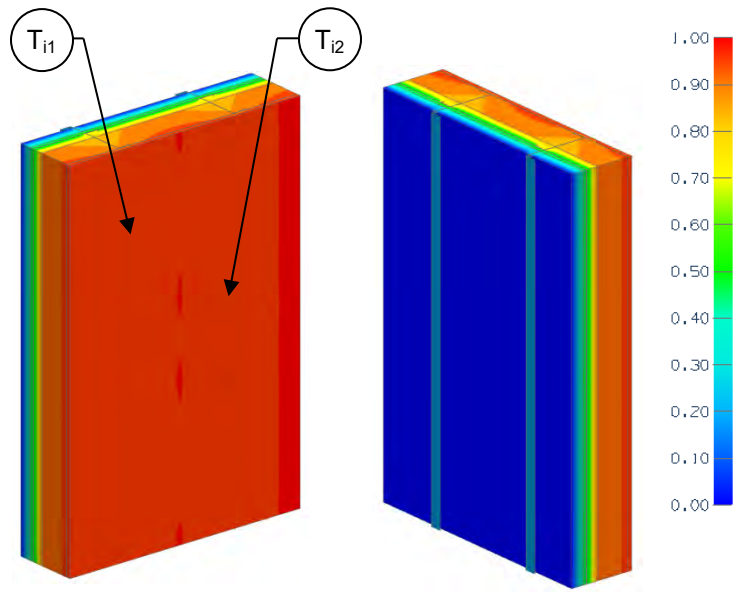

Thermal Performance Indicators

Assembly 1D (Nominal) R-Value	R_{1D}	R-12.6 (2.22 RSI) + exterior insulation
Transmittance / Resistance without Anomaly	U_o, R_o	"clear wall" U- and R-value
Surface Temperature Index ¹	T_i	0 = exterior temperature 1 = interior temperature

¹Assumptions and limitations for surface temperatures identified in ASHRAE 1365-RP

View from Interior

View from Exterior

Nominal (1D) vs. Assembly Performance Indicators

Exterior Insulation 1D R-Value (RSI)	R_{1D} ft ² ·hr·°F / Btu (m ² K / W)	R_o ft ² ·hr·°F / Btu (m ² K / W)	U_o Btu/ft ² ·hr·°F (W/m ² K)
R-10.1 (1.78)	R-22.7 (4.00)	R-11.6 (2.04)	0.086 (0.42)

Temperature Indices

	R10	
T_{i1}	0.78	Min T on Spray Foam, beside studs
T_{i2}	0.81	Max T on Spray Foam, between studs

Detail 5.1.8

Exterior and Interior Insulated 6" x 1 5/8" Steel Stud (16" o.c.) Wall Assembly with Vertical Z-Girts (16" o.c.) and 2" Spray Foam (R-11.4) in Stud Cavity – Clear Wall

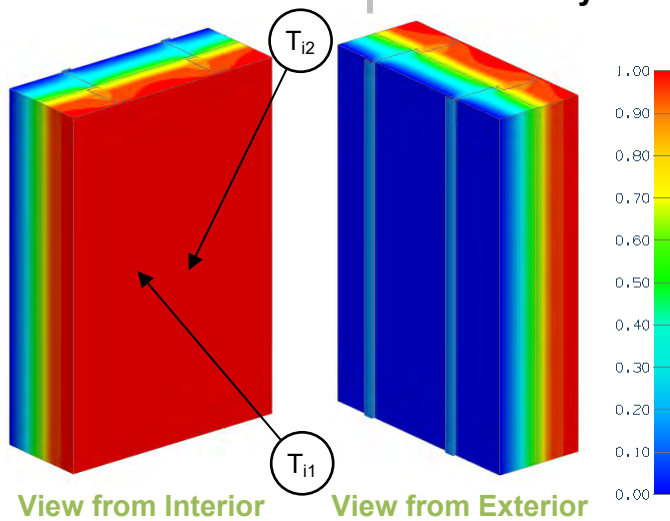

Thermal Performance Indicators

Assembly 1D (Nominal) R-Value	R_{1D}	R-14.6 (2.57) + insulation
Transmittance / Resistance without Anomaly	U_o, R_o	"clear field" U- and R-value, without connectors or joint
Surface Temperature Index ¹	T_i	0 = exterior temperature 1 = interior temperature

Nominal (1D) vs. Assembly Performance Indicators

Exterior Insulation 1D R-Value (RSI)	R_{1D} ft ² ·hr·°F / Btu (m ² K / W)	R_o ft ² ·hr·°F / Btu (m ² K / W)	U_o Btu/ft ² ·hr ·°F (W/m ² K)
R-10.0 (1.76)	R-24.6 (4.33)	R-12.0 (2.11)	0.083 (0.47)
R-15.0 (2.64)	R-29.6 (5.21)	R-13.2 (2.32)	0.076 (0.43)
R-20.0 (3.52)	R-34.6 (6.09)	R-14.2 (2.50)	0.071 (0.40)
R-25.0 (4.40)	R-39.6 (6.97)	R-15.1 (2.66)	0.066 (0.38)
R-30.0 (5.28)	R-44.6 (7.85)	R-15.9 (2.80)	0.063 (0.36)

Temperature Indices

	R10	R15	R20	R25	R30	
T_{i1}	0.79	0.81	0.82	0.83	0.84	Min T on Spray Foam, beside studs
T_{i2}	0.88	0.90	0.90	0.91	0.92	Max T on Spray Foam, between studs

Detail 5.1.9

Exterior Insulated 3 5/8" x 1 5/8" Steel Stud (16" O.C.) Wall Assembly with Horizontal Z-Girts (24" O.C.) Supporting Metal Cladding – Clear Wall

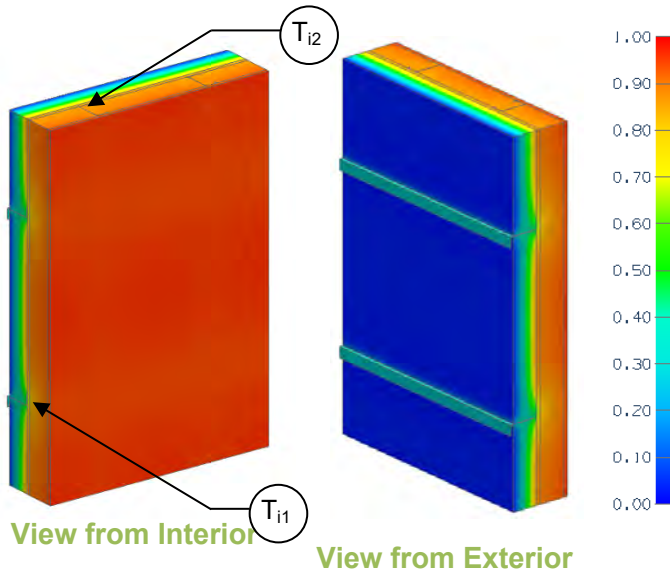

Thermal Performance Indicators

Assembly 1D (Nominal) R-Value	R_{1D}	R-3.2 (0.56 RSI) + exterior insulation
Transmittance / Resistance	U_o, R_o	"clear wall" U- and R-value
Surface Temperature Index ¹	T_i	0 = exterior temperature 1 = interior temperature

¹Assumptions and limitations for surface temperatures identified in ASHRAE 1365-RP

Nominal (1D) vs. Assembly Performance Indicators

Exterior Insulation 1D R-Value (RSI)	R_{1D} ft ² ·hr·°F / Btu (m ² K / W)	R_o ft ² ·hr·°F / Btu (m ² K / W)	U_o Btu/ft ² ·hr·°F (W/m ² K)
R-5 (0.88)	R-8.2 (1.44)	R-6.8 (1.21)	0.146 (0.83)
R-10 (1.76)	R-13.2 (2.32)	R-9.4 (1.66)	0.106 (0.60)
R-15 (2.64)	R-18.2 (3.20)	R-11.3 (1.99)	0.088 (0.50)
R-20 (3.52)	R-23.2 (4.08)	R-13.1 (2.31)	0.076 (0.43)
R-25 (4.40)	R-28.2 (4.96)	R-14.5 (2.56)	0.069 (0.39)

Detail 5.1.10

Exterior and Interior Insulated 6" x 1/58" Steel Stud (16" o.c.) Wall Assembly with Horizontal Z-Girts (24" o.c.) Supporting Cladding, Owens Corning ThermaFiber RainBarrier HC Max Insulation and R-20 Batt Insulation in Stud Cavity – Clear Wall

Thermal Performance Indicators

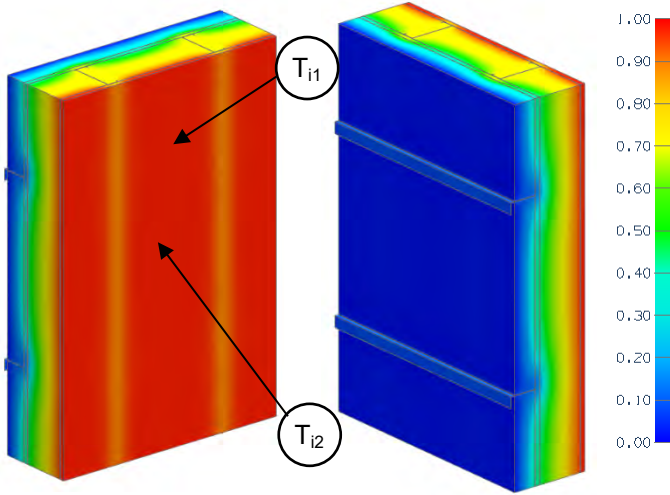

Assembly 1D (Nominal) R-Value	R _{1D}	R-22.5 (3.96 RSI) + exterior insulation
Transmittance / Resistance	U _o , R _o	"clear wall" U- and R-value
Surface Temperature Index	T _i	0 = exterior temperature 1 = interior temperature

View from Interior View from Exterior

Nominal (1D) vs. Assembly Performance Indicators

Exterior Insulation 1D R-Value (RSI)	R _{1D} ft ² ·hr·°F / Btu (m ² K / W)	R _o ft ² ·hr·°F / Btu (m ² K / W)	U _o Btu/ft ² ·hr·°F (W/m ² K)
R-4.0 (0.70)	R-26.5 (4.67)	R-15.9 (2.80)	0.063 (0.357)
R-8.0 (1.41)	R-30.5 (5.37)	R-18.4 (3.24)	0.054 (0.308)
R-12.0 (2.11)	R-34.5 (6.08)	R-20.9 (3.68)	0.048 (0.272)
R-16.0 (2.82)	R-38.5 (6.78)	R-22.7 (4.00)	0.044 (0.250)
R-20.0 (3.52)	R-42.5 (7.48)	R-24.5 (4.31)	0.041 (0.232)
R-24.0 (4.23)	R-46.5 (8.19)	R-26.0 (4.58)	0.038 (0.218)

Temperature Indices

	R4	R12	R20	R24	
T _{i1}	0.14	0.23	0.29	0.31	Min T on sheathing, along girts between studs
T _{i2}	0.22	0.43	0.57	0.57	Max T on sheathing, between studs and girt

Temperature indices listed for selected scenarios. All other scenarios to be interpolated.

Detail 5.1.11

Exterior and Interior Insulated 6" x 1 5/8" Steel Stud (16" o.c.) Wall Assembly with Horizontal Z-Girts (24" o.c.) Supporting Cladding, Owens Corning ThermaFiber RainBarrier HC Plus 110 Insulation and R-20 Batt Insulation in Stud Cavity – Clear Wall

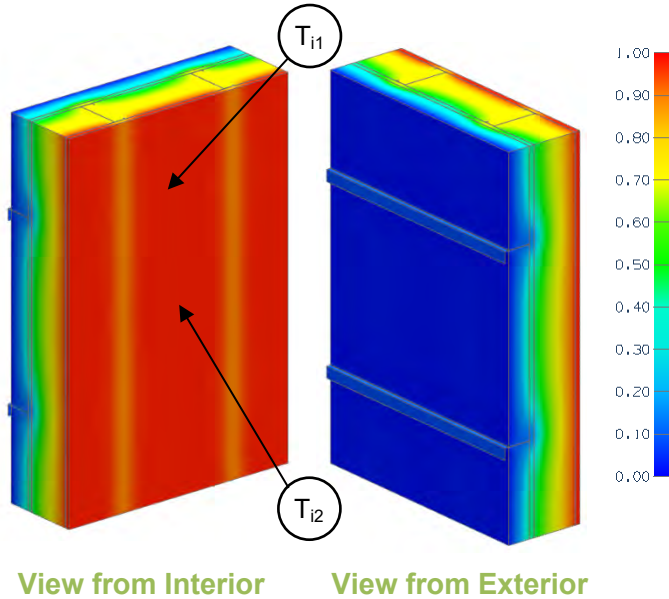

Thermal Performance Indicators

Assembly 1D (Nominal) R-Value	R_{1D}	R-22.5 (3.96 RSI) + exterior insulation
Transmittance / Resistance	U_o, R_o	"clear wall" U- and R-value
Surface Temperature Index	T_i	0 = exterior temperature 1 = interior temperature

Nominal (1D) vs. Assembly Performance Indicators

Exterior Insulation 1D R-Value (RSI)	R_{1D} ft ² ·hr·°F / Btu (m ² K / W)	R_o ft ² ·hr·°F / Btu (m ² K / W)	U_o Btu/ft ² ·hr·°F (W/m ² K)
R-4.1 (0.72)	R-26.6 (4.68)	R-16.0 (2.82)	0.063 (0.355)
R-8.2 (1.44)	R-30.7 (5.41)	R-18.5 (3.26)	0.054 (0.306)
R-12.3 (2.17)	R-34.8 (6.13)	R-21.1 (3.71)	0.047 (0.270)
R-16.4 (2.89)	R-38.9 (6.85)	R-22.9 (4.03)	0.044 (0.248)
R-20.5 (3.61)	R-43.0 (7.57)	R-24.7 (4.35)	0.041 (0.230)
R-24.6 (4.33)	R-47.1 (8.29)	R-26.2 (4.62)	0.038 (0.217)

Temperature Indices

	R4.1	R12.3	R20.5	R24.6	
T_{i1}	0.14	0.23	0.29	0.31	Min T on sheathing, along girts between studs
T_{i2}	0.23	0.43	0.58	0.58	Max T on sheathing, between studs and girt

Temperature indices listed for selected scenarios. All other scenarios to be interpolated.

Detail 5.1.12

Exterior and Interior Insulated 6" x 1 5/8" Steel Stud (16" o.c.) Wall Assembly with Horizontal Z-Girts (24" o.c.) Supporting Cladding, Owens Corning ThermaFiber RainBarrier 45 Insulation and R-20 Batt Insulation in Stud Cavity – Clear Wall

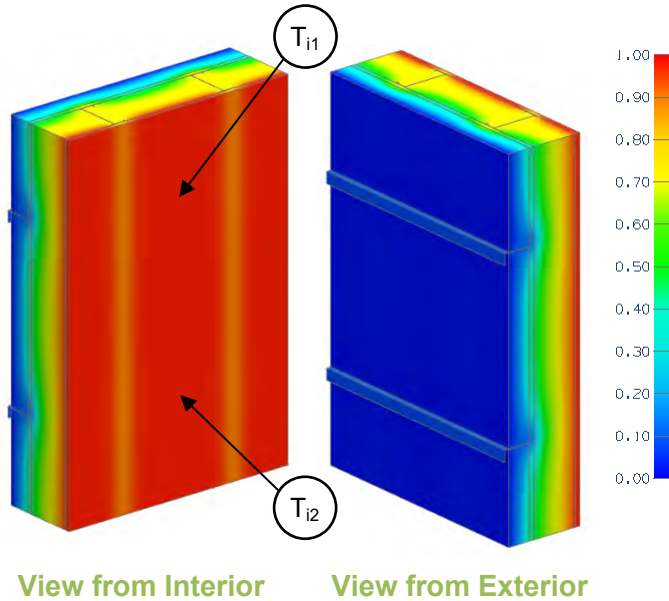

Thermal Performance Indicators

Assembly 1D (Nominal) R-Value	R_{1D}	R-22.5 (3.96 RSI) + exterior insulation
Transmittance / Resistance	U_o, R_o	"clear wall" U- and R-value
Surface Temperature Index	T_i	0 = exterior temperature 1 = interior temperature

Nominal (1D) vs. Assembly Performance Indicators

Exterior Insulation 1D R-Value (RSI)	R_{1D} ft ² ·hr·°F / Btu (m ² K / W)	R_o ft ² ·hr·°F / Btu (m ² K / W)	U_o Btu/ft ² ·hr ·°F (W/m ² K)
R-4.2 (0.74)	R-26.7 (4.70)	R-16.1 (2.83)	0.062 (0.353)
R-8.4 (1.48)	R-30.9 (5.44)	R-18.6 (3.28)	0.054 (0.304)
R-12.6 (2.22)	R-35.1 (6.18)	R-21.2 (3.74)	0.047 (0.268)
R-16.8 (2.96)	R-39.3 (6.92)	R-23.1 (4.06)	0.043 (0.246)
R-21.0 (3.70)	R-43.5 (7.66)	R-24.9 (4.38)	0.040 (0.228)
R-25.2 (4.44)	R-47.7 (8.40)	R-26.4 (4.66)	0.038 (0.215)

Temperature Indices

	R4.2	R12.6	R21.0	R25.2	
T_{i1}	0.14	0.23	0.29	0.31	Min T on sheathing, along girts between studs
T_{i2}	0.23	0.44	0.55	0.58	Max T on sheathing, between studs and girt

Temperature indices listed for selected scenarios. All other scenarios to be interpolated.

Detail 5.1.13

Exterior and Interior Insulated 3 5/8" x 1 5/8" Steel Stud (16" o.c.) Wall Assembly with Vertical Z-girts (16" o.c.) Supporting Stucco Cladding and R-12 Batt Insulation in Stud Cavity – Clear Wall

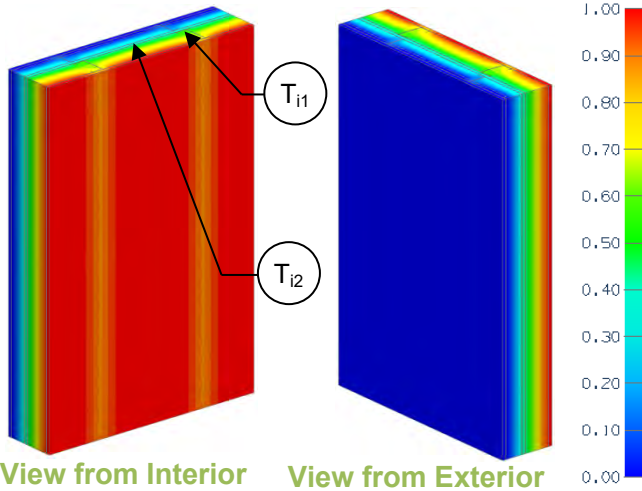

Thermal Performance Indicators

Assembly 1D (Nominal) R-Value	R_{1D}	R-14.5 (2.55 RSI) + exterior insulation
Transmittance / Resistance	U_o , R_o	“clear wall” U- and R-value
Surface Temperature Index ¹	T_i	0 = exterior temperature 1 = interior temperature

¹Assumptions and limitations for surface temperatures identified in ASHRAE 1365-RP

Nominal (1D) vs. Assembly Performance Indicators

Exterior Insulation 1D R-Value (RSI)	R_{1D} ft ² ·hr·°F / Btu (m ² K / W)	R_o ft ² ·hr·°F / Btu (m ² K / W)	U_o Btu/ft ² ·hr ·°F (W/m ² K)
R-10 (1.76)	R-24.5 (4.31)	R-13.0 (2.29)	0.077 (0.44)
R-15 (2.64)	R-29.5 (5.20)	R-14.1 (2.49)	0.071 (0.40)
R-20 (3.52)	R-34.5 (6.08)	R-15.1 (2.66)	0.066 (0.38)

Temperature Indices

	R10	R15	R20	
T_{i1}	0.42	0.47	0.49	Min T on sheathing, beside studs
T_{i2}	0.48	0.53	0.57	Max T on sheathing, between studs

Detail 5.1.14

Exterior and Interior Insulated 3 5/8" x 1 5/8" Steel Stud (16" o.c) Wall Assembly with Horizontal Z-Girts (24" o.c.) Supporting Metal Cladding and R-12 Batt Insulation in Stud Cavity – Clear Wall

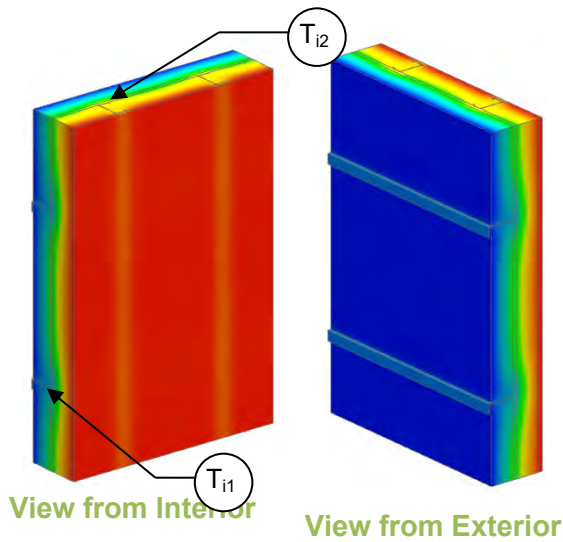

Thermal Performance Indicators

Assembly 1D (Nominal) R-Value	R_{1D}	R-14.2 (2.50 RSI) + exterior insulation
Transmittance / Resistance	U_o, R_o	"clear wall" U- and R-value
Surface Temperature Index ¹	T_i	0 = exterior temperature 1 = interior temperature

¹Assumptions and limitations for surface temperatures identified in ASHRAE 1365-RP

Nominal (1D) vs. Assembly Performance Indicators

Exterior Insulation 1D R-Value (RSI)	R_{1D} ft ² ·hr·°F / Btu (m ² K / W)	R_o ft ² ·hr·°F / Btu (m ² K / W)	U_o Btu/ft ² ·hr·°F (W/m ² K)
R-0 (0)	R-14.2 (2.50)	R-9.2 (1.62)	0.109 (0.62)
R-5 (0.88)	R-19.2 (3.38)	R-13.4 (2.36)	0.075 (0.42)
R-10 (1.76)	R-24.2 (4.26)	R-16.3 (2.87)	0.061 (0.35)
R-15 (2.64)	R-29.2 (5.14)	R-18.5 (3.25)	0.054 (0.31)
R-20 (3.52)	R-34.2 (6.02)	R-20.5 (3.61)	0.049 (0.28)
R-25 (4.40)	R-39.2 (6.90)	R-22.1 (3.90)	0.045 (0.26)

Temperature Indices

	R0	R5	R10	R15	R20	R25	
T_{i1}	0.06	0.21	0.28	0.32	0.36	0.38	Min T on sheathing, along girts between studs
T_{i2}	0.35	0.59	0.68	0.72	0.75	0.78	Max T on sheathing, along studs between girts

Detail 5.1.15

Exterior and Interior Insulated 6" x 1 5/8" Steel Stud (16" o.c.) Wall Assembly with Horizontal Z-Girts (24" o.c.) and 1 1/2" Spray Foam (R-9.8) in Stud Cavity – Clear Wall

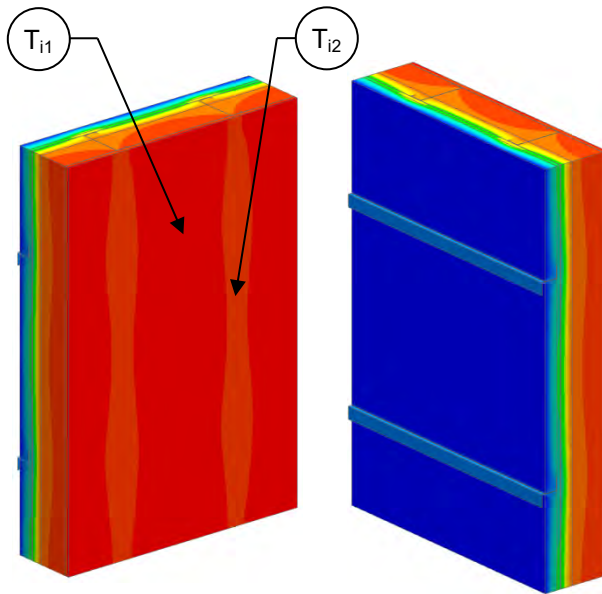

View from Interior

View from Exterior

Thermal Performance Indicators



Assembly 1D (Nominal) R-Value	R_{1D}	R-12.6 (2.22 RSI) + exterior insulation
Transmittance / Resistance without Anomaly	U_o, R_o	"clear wall" U- and R-value
Surface Temperature Index ¹	T_i	0 = exterior temperature 1 = interior temperature

¹Assumptions and limitations for surface temperatures identified in ASHRAE 1365-RP

Nominal (1D) vs. Assembly Performance Indicators

Exterior Insulation 1D R-Value (RSI)	R_{1D} ft ² ·hr·°F / Btu (m ² K / W)	R_o ft ² ·hr·°F / Btu (m ² K / W)	U_o Btu/ft ² ·hr ·°F (W/m ² K)
R-10.1 (1.78)	R-22.7 (4.00)	R-15.2 (2.68)	0.066 (0.37)

Temperature Indices

T_{i1}	0.78	Min T on Spray Foam, along horizontal girts between studs
T_{i2}	0.84	Max T on Spray Foam, along studs between horizontal girts

Detail 5.1.16

Exterior Insulated 3 5/8" x 1 5/8" Steel Stud (16" O.C.) Wall Assembly with Vertical Z-Girts (24" O.C.) & Horizontal Z-Girts (24" O.C.) Supporting Metal Cladding – Clear Wall

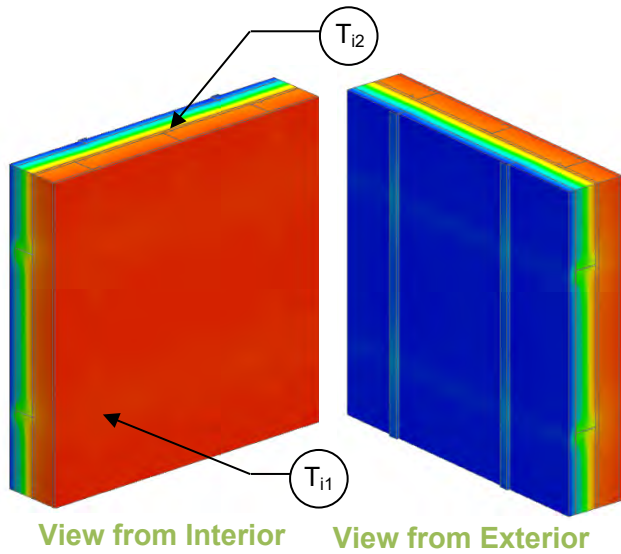

Thermal Performance Indicators

Assembly 1D (Nominal) R Value	R_{1D}	R-3.2 (0.56 RSI) + horizontal exterior insulation + vertical exterior insulation R-5 (0.88 RSI)
Transmittance / Resistance	U_o , R_o	"clear wall" U- and R-value
Surface Temperature Index ¹	T_i	0 = exterior temperature 1 = interior temperature

¹Assumptions and limitations for surface temperatures identified in ASHRAE 1365-RP

Nominal (1D) vs. Assembly Performance Indicators

Exterior Insulation 1D R-Value (RSI)	R_{1D} ft ² ·hr·°F / Btu (m ² K / W)	R_o ft ² ·hr·°F / Btu (m ² K / W)	U_o Btu/ft ² ·hr ·°F (W/m ² K)
R-10 (0.88)	R-13.2 (2.32)	R-10.4 (1.82)	0.097 (0.55)
R-15 (1.76)	R-18.2 (3.20)	R-13.1 (2.31)	0.076 (0.43)
R-20 (2.64)	R-23.2 (4.08)	R-15.3 (2.70)	0.065 (0.37)
R-25 (3.52)	R-28.2 (4.96)	R-17.2 (3.03)	0.058 (0.33)
R-30 (4.40)	R-33.2 (5.84)	R-18.9 (3.33)	0.053 (0.30)

Temperature Indices

	R10	R15	R20	R25	R30	
T_{i1}	0.74	0.77	0.80	0.81	0.82	Min T on sheathing, at vertical and horizontal girt intersection, not at a stud intersection
T_{i2}	0.85	0.89	0.90	0.91	0.93	Max T on sheathing, along studs between girts

Detail 5.1.17

Exterior Insulated 3 5/8" x 1 5/8" Steel Stud (16" O.C.) Wall Assembly with Intermittent Vertical Z-Girts (16" O.C.) Supporting Metal Cladding – Clear Wall

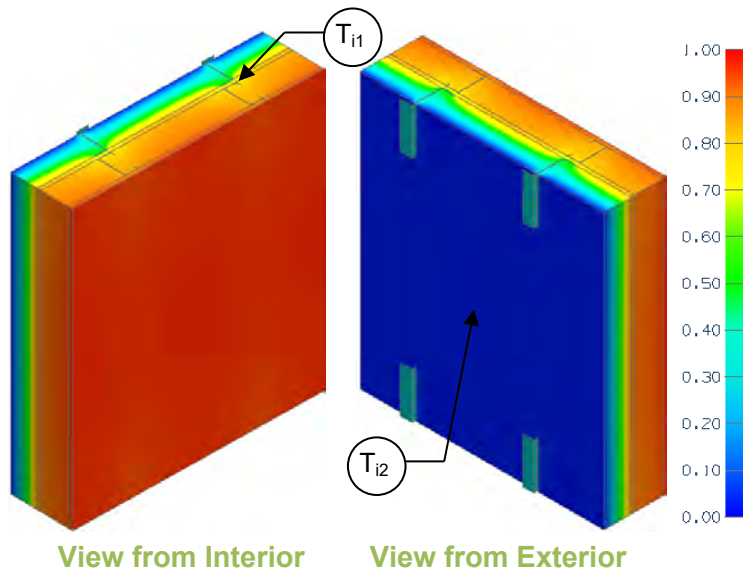

Thermal Performance Indicators

Assembly 1D (Nominal) R-Value	R_{1D}	R-3.2 (0.56 RSI) + horizontal exterior insulation
Transmittance / Resistance	U_o, R_o	“clear wall” U- and R-value. Results for three vertical spacings (12”, 24”, 36”) are presented below
Surface Temperature Index ¹	T_i	0 = exterior temperature 1 = interior temperature

¹Assumptions and limitations for surface temperatures identified in ASHRAE 1365-RP

Nominal (1D) vs. Assembly Performance Indicators

Exterior Insulation 1D R-Value (RSI)	R_{1D} ft ² ·hr·°F / Btu (m ² K / W)	12" Vertical Spacing		24" Vertical Spacing		36" Vertical Spacing	
		R_o ft ² ·hr·°F / Btu (m ² K / W)	U_o Btu/ft ² ·hr ·°F (W/m ² K)	R_o ft ² ·hr·°F / Btu (m ² K / W)	U_o Btu/ft ² ·hr ·°F (W/m ² K)	R_o ft ² ·hr·°F / Btu (m ² K / W)	U_o Btu/ft ² ·hr ·°F (W/m ² K)
R-5 (0.88)	R-13.2 (2.32)	R-7.0 (1.24)	0.142 (0.81)	R-7.4 (1.30)	0.136 (0.77)	R-7.6 (1.33)	0.132 (0.75)
R-10 (1.76)	R-18.2 (3.20)	R-9.9 (1.74)	0.101 (0.58)	R-10.8 (1.90)	0.093 (0.53)	R-11.3 (1.99)	0.089 (0.50)
R-15 (2.64)	R-23.2 (4.08)	R-12.2 (2.15)	0.082 (0.47)	R-13.7 (2.41)	0.073 (0.42)	R-14.6 (2.57)	0.068 (0.39)
R-20 (3.52)	R-28.2 (4.96)	R-14.2 (2.50)	0.070 (0.40)	R-16.3 (2.87)	0.061 (0.35)	R-17.6 (3.10)	0.057 (0.32)
R-25 (4.40)	R-33.2 (5.84)	R-16.1 (2.83)	0.062 (0.35)	R-18.7 (3.30)	0.053 (0.30)	R-20.4 (3.60)	0.049 (0.28)

Temperature Indices

Spacing	T_i	R5	R10	R15	R20	R25	
12"	T_{i1}	0.62	0.69	0.73	0.75	0.77	Min T on sheathing, at girt and stud intersection
	T_{i2}	0.75	0.83	0.87	0.89	0.90	Max T on sheathing, centre of stud cavity between girts
24"	T_{i1}	0.63	0.70	0.73	0.76	0.78	Min T on sheathing, at girt and stud intersection
	T_{i2}	0.77	0.85	0.88	0.90	0.92	Max T on sheathing, centre of stud cavity between girts
36"	T_{i1}	0.63	0.70	0.73	0.76	0.78	Min T on sheathing, at girt and stud intersection
	T_{i2}	0.78	0.86	0.90	0.92	0.93	Max T on sheathing, centre of stud cavity between girts

Detail 5.1.18

Exterior Insulated 3 5/8" x 1 5/8" Steel Stud (16" o.c.) Wall Assembly with Horizontal Clips (24" o.c.) Supporting Metal Cladding – Clear Wall

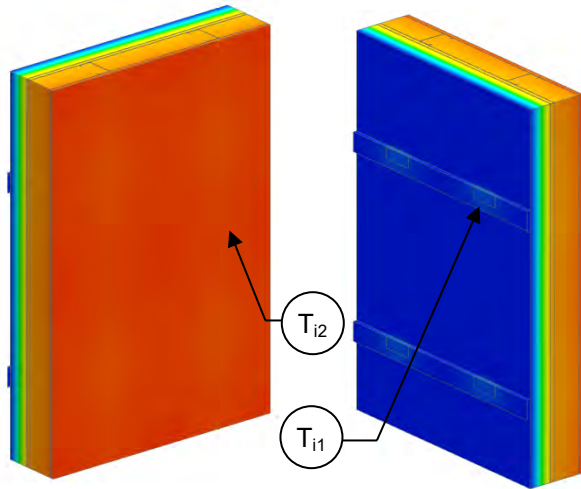

View from Interior

View from Exterior

Thermal Performance Indicators

Assembly 1D (Nominal) R-Value	R_{1D}	R-3.2 (0.56 RSI) + exterior insulation
Transmittance / Resistance	U_o, R_o	"clear wall" U- and R-value
Surface Temperature Index ¹	T_i	0 = exterior temperature 1 = interior temperature

¹Assumptions and limitations for surface temperatures identified in ASHRAE 1365-RP

Nominal (1D) vs. Assembly Performance Indicators

Exterior Insulation 1D R-Value (RSI)	R_{1D} ft ² ·hr·°F / Btu (m ² K / W)	R_o ft ² ·hr·°F / Btu (m ² K / W)	U_o Btu/ft ² ·hr ·°F (W/m ² K)
R-15 (2.64)	R-18.2 (3.20)	R-14.7 (2.59)	0.068 (0.39)
R-20 (3.52)	R-23.2 (4.08)	R-17.8 (3.13)	0.056 (0.32)
R-25 (4.40)	R-28.2 (4.96)	R-20.6 (3.63)	0.049 (0.28)

Temperature Indices

	R15	R20	R25	
T_{i1}	0.75	0.78	0.80	Min T on sheathing, along girts at stud and clip intersection
T_{i2}	0.88	0.90	0.91	Max T on sheathing at stud away from clip

Detail 5.1.19

Exterior and Interior Insulated 3 5/8" x 1 5/8" Steel Stud (16" o.c.) Wall Assembly with Horizontal Clips (24" o.c.) Supporting Metal Cladding and R-12 Batt Insulation in Stud Cavity – Clear Wall

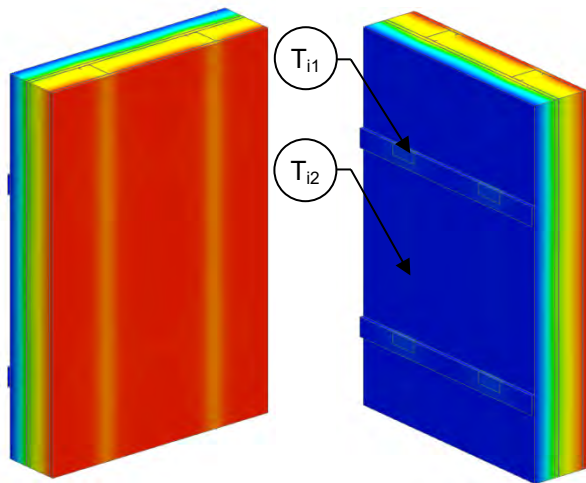

View from Interior

View from Exterior

Thermal Performance Indicators

Assembly 1D (Nominal) R-Value	R_{1D}	R-14.4 (2.54 RSI) + exterior insulation
Transmittance / Resistance	U_o, R_o	"clear wall" U- and R-value
Surface Temperature Index ¹	T_i	0 = exterior temperature 1 = interior temperature

¹Assumptions and limitations for surface temperatures identified in ASHRAE 1365-RP

Nominal (1D) vs. Assembly Performance Indicators

Exterior Insulation 1D R-Value (RSI)	R_{1D} ft ² ·hr·°F / Btu (m ² K / W)	R_o ft ² ·hr·°F / Btu (m ² K / W)	U_o Btu/ft ² ·hr ·°F (W/m ² K)
R-10 (1.76)	R-24.4 (4.30)	R-17.3 (3.04)	0.058 (0.33)
R-15 (2.64)	R-29.4 (5.18)	R-20.6 (3.62)	0.049 (0.28)
R-20 (3.52)	R-34.4 (6.06)	R-23.6 (4.16)	0.042 (0.24)

Temperature Indices

	R10	R15	R20	
T_{i1}	0.44	0.50	0.55	Min T on sheathing, at stud and girt intersection
T_{i2}	0.69	0.74	0.78	Max T on sheathing, at stud, between girts

Detail 5.1.20

Exterior and Interior Insulated 3 5/8" x 1 5/8" Steel Stud (16" o.c.) Wall Assembly with Vertical Z Clips (16" o.c.) Supporting Stucco Cladding and R-12 Batt Insulation in Stud Cavity – Clear Wall

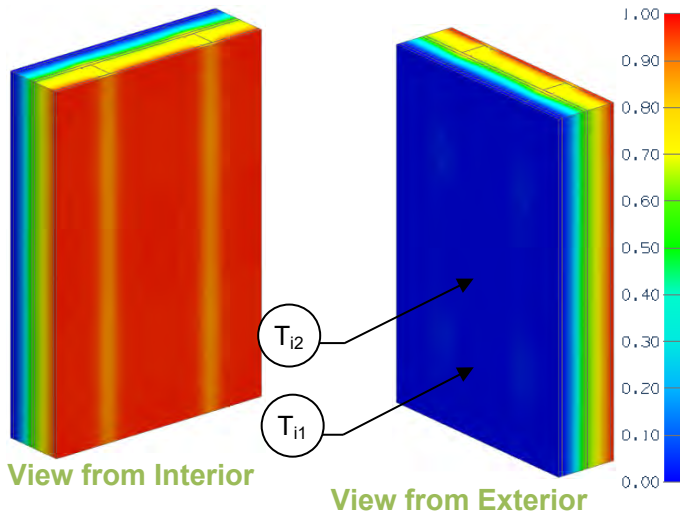

Thermal Performance Indicators

Assembly 1D (Nominal) R Value	R _{1D}	R-14.5 (2.55 RSI) + exterior insulation
Transmittance / Resistance	U _o , R _o	“clear wall” U- and R-value
Surface Temperature Index ¹	T _i	0 = exterior temperature 1 = interior temperature

¹Assumptions and limitations for surface temperatures identified in ASHRAE 1365-RP

Nominal (1D) vs. Assembly Performance Indicators

Exterior Insulation 1D R-Value (RSI)	R _{1D} ft ² ·hr·°F / Btu (m ² K / W)	R _o ft ² ·hr·°F / Btu (m ² K / W)	U _o Btu/ft ² ·hr ·°F (W/m ² K)
R-10 (1.76)	R-24.5 (4.31)	R-16.0 (2.82)	0.062 (0.35)
R-15 (2.64)	R-29.5 (5.20)	R-18.6 (3.28)	0.054 (0.30)
R-20 (3.52)	R-34.5 (6.08)	R-21.0 (3.70)	0.048 (0.27)

Temperature Indices

	R10	R15	R20	
T _{i1}	0.45	0.51	0.55	Min T on sheathing, at clip to stud connection
T _{i2}	0.67	0.72	0.75	Max T on sheathing, at stud, between clips

Detail 5.1.21

Exterior Insulated 6" x 1 5/8" Steel Stud (16" o.c.) Wall Assembly with Knight MFI-System (24" o.c.) Supporting Cladding – Clear Wall

Thermal Performance Indicators

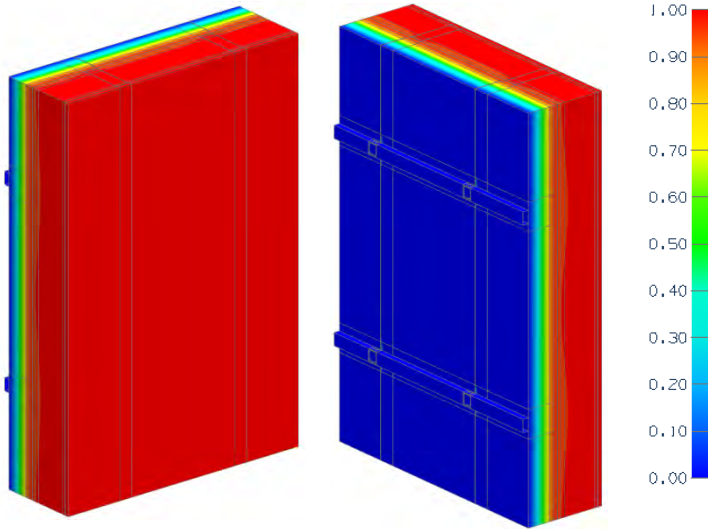

View from Interior

View from Exterior

Assembly 1D (Nominal) R-Value	R_{1D}	R-3.2 (0.56 RSI) + exterior insulation
Transmittance / Resistance	U_o, R_o	"clear wall" U- and R-value

Nominal (1D) vs. Assembly Performance Indicators

Exterior Insulation 1D R-Value (RSI)	R_{1D} ft ² ·hr·°F / Btu (m ² K / W)	R_o ft ² ·hr·°F / Btu (m ² K / W)	U_o Btu/ft ² ·hr ·°F (W/m ² K)
R-8.4 (1.48)	R-11.6 (2.04)	R-10.8 (1.90)	0.093 (0.53)
R-12.6 (2.22)	R-15.8 (2.78)	R-14.1 (2.48)	0.071 (0.40)
R-14.7 (2.59)	R-17.9 (3.15)	R-15.7 (2.77)	0.064 (0.36)
R-16.8 (2.96)	R-20.0 (3.52)	R-17.2 (3.03)	0.058 (0.33)
R-21.0 (3.70)	R-24.2 (4.26)	R-20.1 (3.54)	0.050 (0.28)
R-25.2 (4.44)	R-28.4 (5.00)	R-22.7 (4.00)	0.044 (0.25)

Detail 5.1.22

Exterior and Interior Insulated 6" x 1 5/8" Steel Stud (16" o.c.) Wall Assembly with Knight MFI-System (24" o.c.) Supporting Cladding and R-19 Batt Insulation in Stud Cavity – Clear Wall

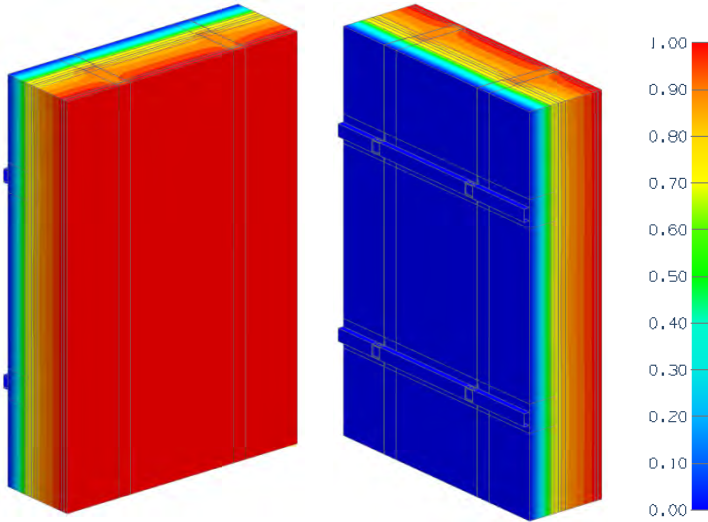

View from Interior

View from Exterior

Thermal Performance Indicators

Assembly 1D (Nominal) R-Value	R_{1D}	R-21.3 (3.75 RSI) + exterior insulation
Transmittance / Resistance	U_o, R_o	"clear wall" U- and R-value

Nominal (1D) vs. Assembly Performance Indicators

Exterior Insulation 1D R-Value (RSI)	R_{1D} ft ² ·hr·°F / Btu (m ² K / W)	R_o ft ² ·hr·°F / Btu (m ² K / W)	U_o Btu/ft ² ·hr ·°F (W/m ² K)
R-8.4 (1.48)	R-29.7 (5.23)	R-19.2 (3.38)	0.052 (0.30)
R-12.6 (2.22)	R-33.9 (5.97)	R-22.5 (3.96)	0.045 (0.26)
R-14.7 (2.59)	R-36.0 (6.34)	R-24.0 (4.23)	0.042 (0.24)
R-16.8 (2.96)	R-38.1 (6.71)	R-25.4 (4.47)	0.039 (0.22)
R-21.0 (3.70)	R-42.3 (7.45)	R-28.2 (4.97)	0.035 (0.20)
R-25.2 (4.44)	R-46.5 (8.19)	R-30.8 (5.42)	0.032 (0.18)

Detail 5.1.23

Exterior Insulated 3 5/8" x 1 5/8" Steel Stud (16" o.c.) Wall Assembly with CL-Talon 300 Clip System Supporting Cladding – Clear Wall

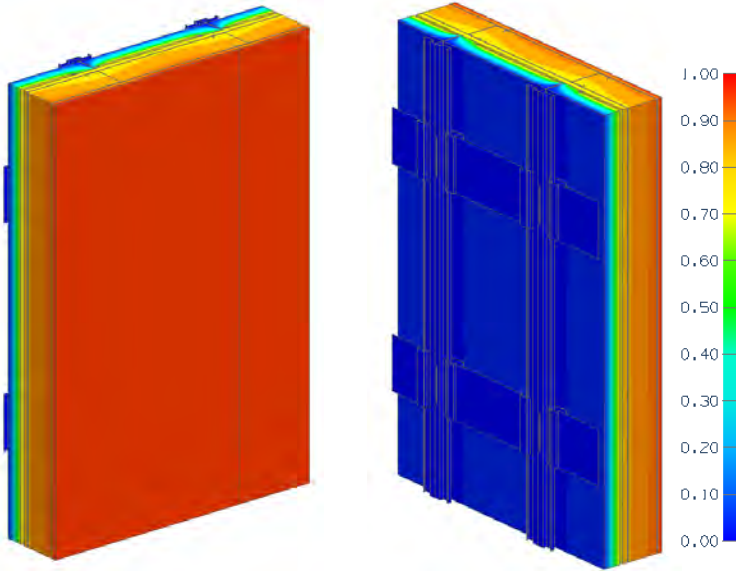

Thermal Performance Indicators

Assembly 1D (Nominal) R-Value	R_{1D}	R-3.4 (0.60 RSI) + exterior insulation
Transmittance / Resistance	U_o, R_o	"clear field" U- and R-values
Surface Temperature Index ¹	T_i	0 = exterior temperature 1 = interior temperature

¹Assumptions and limitations for surface temperatures identified in ASHRAE 1365-RP

View from Interior

View from Exterior

Nominal (1D) vs. Assembly Performance Indicators

Exterior Insulation 1D R-value (RSI)	R_{1D} ft ² ·hr·°F / Btu (m ² K / W)	24" Vertical Spacing		36" Vertical Spacing		48" Vertical Spacing	
		R_o ft ² ·hr·°F / Btu (m ² K / W)	U_o Btu/ft ² ·hr·°F (W/m ² K)	R_o ft ² ·hr·°F / Btu (m ² K / W)	U_o Btu/ft ² ·hr·°F (W/m ² K)	R_o ft ² ·hr·°F / Btu (m ² K / W)	U_o Btu/ft ² ·hr·°F (W/m ² K)
R-8.4 (1.48)	R-11.8 (2.08)	R-9.1 (1.61)	0.110 (0.622)	R-9.3 (1.63)	0.108 (0.612)	R-9.4 (1.65)	0.107 (0.606)
R-12.6 (2.22)	R-16.0 (2.82)	R-13.7 (2.41)	0.073 (0.416)	R-14.3 (2.52)	0.070 (0.397)	R-14.4 (2.54)	0.069 (0.393)
R-16.8 (2.96)	R-20.2 (3.56)	R-17.6 (3.09)	0.057 (0.323)	R-17.9 (3.15)	0.056 (0.317)	R-18.5 (3.26)	0.054 (0.307)

Detail 5.1.24

Exterior Insulated 3 5/8" x 1 5/8" Steel Stud (16" o.c.) Wall Assembly with Thermally Isolated Aluminum Clip Horizontal Sub-girt System Supporting Cladding – Clear Wall

Thermal Performance Indicators

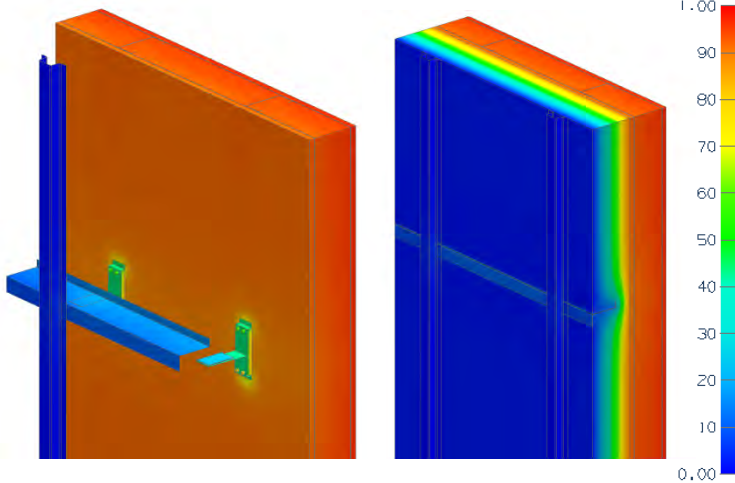

Assembly 1D (Nominal) R-Value	R_{1Da}	R-3.2 (0.56 RSI) + exterior insulation (without fiberglass batt insulation)
Assembly 1D (Nominal) R-Value	R_{1Db}	R-14.4 (2.54 RSI) + exterior insulation and fiberglass batt insulation ¹
Transmittance / Resistance	U_a , R_a , U_b , R_b	“Clear wall” U- and R-value: a = without batt insulation b = with batt insulation

¹If insulation in stud cavity is used, R-0.9 insulation for the cavity space is eliminated

View of Isolated Clips View from Exterior

Nominal (1D) vs. Assembly Performance Indicators

Clear Wall – Exterior Insulated Assembly

Clip System	Exterior Insulation 1D R-Value (RSI)	R_{1Da} ft ² ·hr·°F / Btu (m ² K / W)	34" Vertical Clip Spacing		41" Vertical Clip Spacing		48" Vertical Clip Spacing	
			R_a ft ² ·hr·°F / Btu (m ² K / W)	U_a Btu/ft ² ·hr·°F (W/m ² K)	R_a ft ² ·hr·°F / Btu (m ² K / W)	U_a Btu/ft ² ·hr·°F (W/m ² K)	R_a ft ² ·hr·°F / Btu (m ² K / W)	U_a Btu/ft ² ·hr·°F (W/m ² K)
T100	R-16.8 (2.96)	R-20.0 (3.52)	R-16.4 (2.89)	0.061 (0.35)	R-16.9 (2.98)	0.059 (0.34)	R-17.3 (3.04)	0.058 (0.33)
T125	R-21.0 (3.70)	R-24.2 (4.26)	R-19.7 (3.48)	0.051 (0.29)	R-20.4 (3.60)	0.049 (0.28)	R-20.9 (3.68)	0.048 (0.27)
T150	R-25.2 (4.44)	R-28.4 (5.00)	R-22.7 (3.99)	0.044 (0.25)	R-23.6 (4.15)	0.042 (0.24)	R-24.2 (4.26)	0.041 (0.24)

Clear Wall – Exterior and Interior Insulated Assembly

Clip System	Exterior Insulation 1D R-Value (RSI)	R_{1Db} ft ² ·hr·°F / Btu (m ² K / W)	34" Vertical Clip Spacing		41" Vertical Clip Spacing		48" Vertical Clip Spacing	
			R_b ft ² ·hr·°F / Btu (m ² K / W)	U_b Btu/ft ² ·hr·°F (W/m ² K)	R_b ft ² ·hr·°F / Btu (m ² K / W)	U_b Btu/ft ² ·hr·°F (W/m ² K)	R_b ft ² ·hr·°F / Btu (m ² K / W)	U_b Btu/ft ² ·hr·°F (W/m ² K)
T100	R-16.8 (2.96)	R-31.2 (5.50)	R-22.2 (3.91)	0.045 (0.26)	R-22.7 (4.00)	0.044 (0.25)	R-22.7 (4.00)	0.044 (0.25)
T125	R-21.0 (3.70)	R-35.4 (6.24)	R-25.0 (4.40)	0.040 (0.23)	R-25.6 (4.52)	0.039 (0.22)	R-26.3 (4.63)	0.038 (0.22)
T150	R-25.2 (4.44)	R-39.6 (6.98)	R-27.8 (4.89)	0.036 (0.20)	R-28.6 (5.03)	0.035 (0.20)	R-29.4 (5.18)	0.034 (0.19)

Detail 5.1.25

Exterior Insulated 3 5/8" x 1/58" Steel Stud (16"o.c.) Wall Assembly with Fiber Reinforced Girts (TAC) Supporting Cladding – Clear Wall

Thermal Performance Indicators

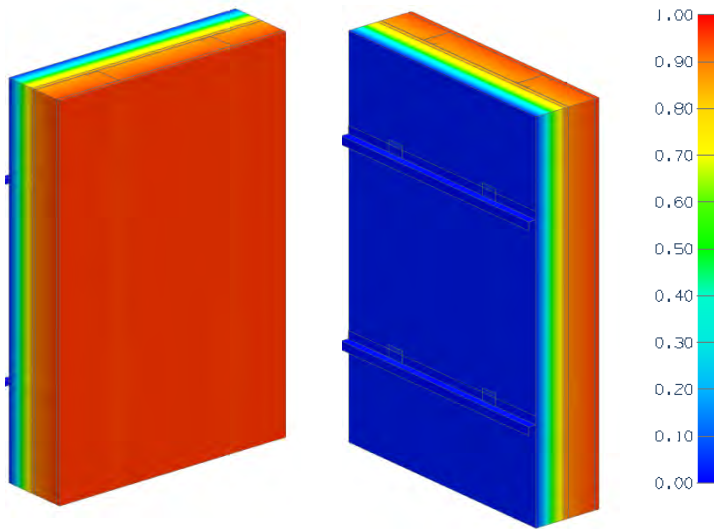

Assembly 1D (Nominal) R-Value	R_{1Da}	R-3.2 (0.56 RSI) + exterior insulation (without fiberglass batt insulation)
Assembly 1D (Nominal) R-Value	R_{1Db}	R-14.4 (2.54 RSI) + exterior insulation and fiberglass batt insulation ¹
Transmittance / Resistance	U_a , $R_{a,}$, U_b , R_b	"Clear wall" U- and R-value: a = without batt insulation b = with batt insulation

¹If insulation in stud cavity is used, R-0.9 insulation for the cavity space is eliminated

View from Interior

View from Exterior

Nominal (1D) vs. Assembly Performance Indicators

Clear Wall – Without Fiberglass Batt Insulation in Stud Cavity

Exterior Insulation 1D R-Value (RSI)	R_{1Da} ft ² ·hr·°F / Btu (m ² K / W)	24" Vertical Clip Spacing		36" Vertical Clip Spacing		48" Vertical Clip Spacing	
		R_a ft ² ·hr·°F / Btu (m ² K / W)	U_a Btu/ft ² ·hr ·°F (W/m ² K)	R_a ft ² ·hr·°F / Btu (m ² K / W)	U_a Btu/ft ² ·hr ·°F (W/m ² K)	R_a ft ² ·hr·°F / Btu (m ² K / W)	U_a Btu/ft ² ·hr ·°F (W/m ² K)
R-12.6 (2.22)	R-15.8 (2.78)	R-15.2 (2.68)	0.066 (0.37)	R-15.4 (2.70)	0.065 (0.37)	R-15.4 (2.70)	0.065 (0.37)
R-16.8 (3.00)	R-20.0 (3.52)	R-19.2 (3.38)	0.052 (0.30)	R-19.2 (3.45)	0.052 (0.29)	R-19.6 (3.45)	0.051 (0.29)
R-21.0 (3.70)	R-24.2 (4.27)	R-23.3 (4.10)	0.043 (0.24)	R-23.8 (4.17)	0.042 (0.24)	R-23.8 (4.17)	0.042 (0.24)
R-25.2 (4.40)	R-28.4 (5.00)	R-27.8 (4.90)	0.036 (0.21)	R-27.8 (4.76)	0.036 (0.21)	R-27.8 (4.76)	0.036 (0.20)

Clear Wall – With Fiberglass Batt Insulation in Stud Cavity

Exterior Insulation 1D R-Value (RSI)	R_{1Db} ft ² ·hr·°F / Btu (m ² K / W)	24" Vertical Clip Spacing		36" Vertical Clip Spacing		48" Vertical Clip Spacing	
		R_b ft ² ·hr·°F / Btu (m ² K / W)	U_b Btu/ft ² ·hr ·°F (W/m ² K)	R_b ft ² ·hr·°F / Btu (m ² K / W)	U_b Btu/ft ² ·hr ·°F (W/m ² K)	R_b ft ² ·hr·°F / Btu (m ² K / W)	U_b Btu/ft ² ·hr ·°F (W/m ² K)
R-12.6 (2.22)	R-27.0 (4.76)	R-21.3 (3.70)	0.047 (0.27)	R-21.7 (3.85)	0.046 (0.26)	R-21.7 (3.85)	0.046 (0.26)
R-16.8 (3.00)	R-31.2 (5.49)	R-25.0 (4.35)	0.039 (0.22)	R-25.6 (4.55)	0.039 (0.22)	R-25.6 (4.55)	0.039 (0.22)
R-21.0 (3.70)	R-35.4 (6.23)	R-29.4 (5.26)	0.034 (0.19)	R-30.3 (5.26)	0.033 (0.19)	R-30.3 (5.26)	0.033 (0.19)
R-25.2 (4.40)	R-39.6 (6.97)	R-33.3 (5.88)	0.030 (0.17)	R-34.5 (5.88)	0.029 (0.17)	R-34.5 (5.88)	0.029 (0.17)

Detail 5.1.26

Exterior Insulated 3 5/8" x 1 5/8" Steel Stud (16" o.c.) Wall Assembly with Thermally Broken Aluminum Clip Rail System (24" o.c.) Supporting Cladding – Clear Wall

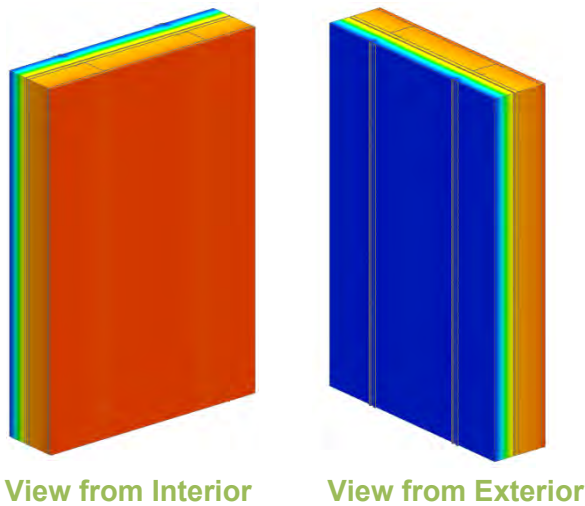

Thermal Performance Indicators

Assembly 1D (Nominal) R-Value	R_{1Da}	R-3.2 (0.56 RSI) + exterior insulation (without fiberglass batt insulation)
Assembly 1D (Nominal) R-Value	R_{1Db}	R-14.4 (2.54 RSI) + exterior insulation and fiberglass batt insulation ¹
Transmittance / Resistance	U_a , R_a , U_b , R_b	"Clear wall" U- and R-value: a = without batt insulation b = with batt insulation

¹If insulation in stud cavity is used, R-0.9 insulation for the cavity space is eliminated

Nominal (1D) vs. Assembly Performance Indicators

Clear Wall – Without Fiberglass Batt Insulation in Stud Cavity

Exterior Insulation 1D R-Value (RSI)	R_{1Da} ft ² ·hr·°F / Btu (m ² K / W)	24" Vertical Clip Spacing		30" Vertical Clip Spacing		36" Vertical Clip Spacing		42" Vertical Clip Spacing	
		R_a ft ² ·hr·°F / Btu (m ² K / W)	U_a Btu/ft ² ·hr·°F (W/m ² K)	R_a ft ² ·hr·°F / Btu (m ² K / W)	U_a Btu/ft ² ·hr·°F (W/m ² K)	R_a ft ² ·hr·°F / Btu (m ² K / W)	U_a Btu/ft ² ·hr·°F (W/m ² K)	R_a ft ² ·hr·°F / Btu (m ² K / W)	U_a Btu/ft ² ·hr·°F (W/m ² K)
R-12.6 (2.22)	R-15.8 (2.78)	R-14.1 (2.47)	0.071 (0.41)	R-14.3 (2.51)	0.070 (0.40)	R-14.5 (2.54)	0.069 (0.39)	R-14.5 (2.56)	0.069 (0.39)
R-16.8 (3.00)	R-20.0 (3.52)	R-16.9 (3.00)	0.059 (0.33)	R-17.5 (3.07)	0.057 (0.33)	R-17.9 (3.13)	0.056 (0.32)	R-17.9 (3.16)	0.056 (0.32)
R-21.0 (3.70)	R-24.2 (4.27)	R-19.6 (3.45)	0.051 (0.29)	R-20.4 (3.57)	0.049 (0.28)	R-20.8 (3.66)	0.048 (0.27)	R-21.3 (3.73)	0.047 (0.27)
R-25.2 (4.40)	R-28.4 (5.00)	R-21.7 (3.86)	0.046 (0.26)	R-22.7 (3.91)	0.044 (0.26)	R-23.8 (4.15)	0.042 (0.24)	R-24.4 (4.26)	0.041 (0.24)

Clear Wall – With Fiberglass Batt Insulation in Stud Cavity

Exterior Insulation 1D R-Value (RSI)	R_{1Db} ft ² ·hr·°F / Btu (m ² K / W)	24" Vertical Clip Spacing		30" Vertical Clip Spacing		36" Vertical Clip Spacing		42" Vertical Clip Spacing	
		R_b ft ² ·hr·°F / Btu (m ² K / W)	U_b Btu/ft ² ·hr·°F (W/m ² K)	R_b ft ² ·hr·°F / Btu (m ² K / W)	U_b Btu/ft ² ·hr·°F (W/m ² K)	R_b ft ² ·hr·°F / Btu (m ² K / W)	U_b Btu/ft ² ·hr·°F (W/m ² K)	R_b ft ² ·hr·°F / Btu (m ² K / W)	U_b Btu/ft ² ·hr·°F (W/m ² K)
R-12.6 (2.22)	R-27.0 (4.76)	R-19.2 (3.37)	0.052 (0.30)	R-20.4 (3.60)	0.049 (0.28)	R-20.8 (3.65)	0.048 (0.27)	R-20.8 (3.68)	0.048 (0.27)
R-16.8 (3.00)	R-31.2 (5.49)	R-23.3 (4.05)	0.043 (0.25)	R-23.3 (4.17)	0.043 (0.24)	R-23.8 (4.23)	0.042 (0.24)	R-23.8 (4.29)	0.041 (0.23)
R-21.0 (3.70)	R-35.4 (6.23)	R-25.6 (4.50)	0.039 (0.22)	R-26.3 (4.65)	0.038 (0.22)	R-27.0 (4.76)	0.037 (0.21)	R-27.0 (4.81)	0.037 (0.21)
R-25.2 (4.40)	R-39.6 (6.97)	R-27.8 (4.93)	0.036 (0.20)	R-29.4 (5.10)	0.034 (0.20)	R-30.3 (5.26)	0.033 (0.19)	R30.3 (5.35)	0.033 (0.19)

Detail 5.1.27

Exterior and Interior Insulated 6" x 1 5/8" Steel Stud (16" o.c.) Wall Assembly with High Compression Insulation and Through Insulation Steel Fasteners (12" o.c.) Supporting Cladding, Owens Corning ThermaFiber RainBarrier HC Max Insulation and R-20 Batt Insulation in Stud Cavity – Clear Wall

Thermal Performance Indicators

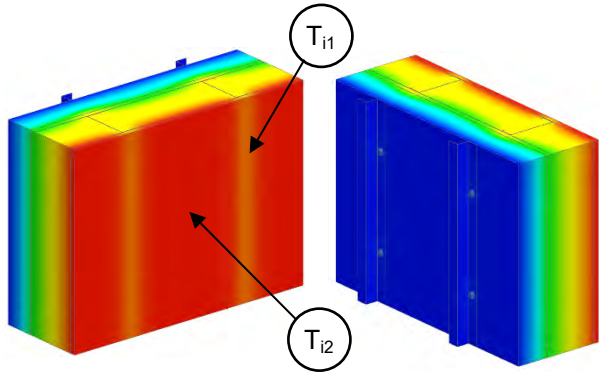

Assembly 1D (Nominal) R-Value	R_{1D}	R-22.5 (3.96 RSI) + exterior insulation
Transmittance / Resistance	U_o, R_o	"clear wall" U- and R-value
Surface Temperature Index	T_i	0 = exterior temperature 1 = interior temperature

View from Interior View from Exterior

Nominal (1D) vs. Assembly Performance Indicators

Exterior Insulation 1D R-Value (RSI)	R_{1D} ft ² ·hr·°F / Btu (m ² K / W)	R_o ft ² ·hr·°F / Btu (m ² K / W)	U_o Btu/ft ² ·hr ·°F (W/m ² K)
R-4.0 (0.70)	R-26.5 (4.67)	R-15.5 (2.72)	0.065 (0.367)
R-8.0 (1.41)	R-30.5 (5.37)	R-18.5 (3.26)	0.054 (0.307)
R-12.0 (2.11)	R-34.5 (6.08)	R-21.6 (3.80)	0.046 (0.263)
R-16.0 (2.82)	R-38.5 (6.78)	R-24.4 (4.30)	0.041 (0.233)

Temperature Indices

	R4	R12	R16	
T_{i1}	0.27	0.41	0.46	Min T on sheathing, at fastener along studs
T_{i2}	0.22	0.44	0.51	Min T on sheathing, between studs and fasteners

Temperature indices listed for selected scenarios. All other scenarios to be interpolated.

Detail 5.1.28

Exterior and Interior Insulated 6" x 1 5/8" Steel Stud (16" o.c.) Wall Assembly with High Compression Insulation and Through Insulation Steel Fasteners (12" o.c.) Supporting Cladding, Owens Corning ThermaFiber RainBarrier HC Plus 110 Insulation and R-20 Batt Insulation in Stud Cavity – Clear Wall

Thermal Performance Indicators

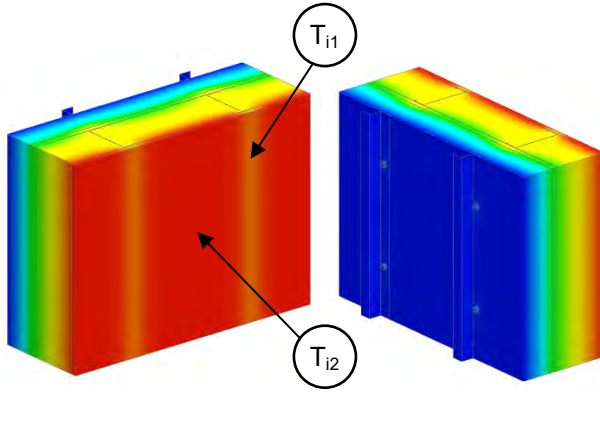

Assembly 1D (Nominal) R-Value	R_{1D}	R-22.5 (3.96 RSI) + exterior insulation
Transmittance / Resistance	U_o, R_o	"clear wall" U- and R-value
Surface Temperature Index	T_i	0 = exterior temperature 1 = interior temperature

View from Interior View from Exterior

Nominal (1D) vs. Assembly Performance Indicators

Exterior Insulation 1D R-Value (RSI)	R_{1D} ft ² ·hr·°F / Btu (m ² K / W)	R_o ft ² ·hr·°F / Btu (m ² K / W)	U_o Btu/ft ² ·hr ·°F (W/m ² K)
R-4.1 (0.72)	R-26.6 (4.68)	R-15.5 (2.74)	0.064 (0.366)
R-8.2 (1.44)	R-30.7 (5.41)	R-18.6 (3.28)	0.054 (0.305)
R-12.3 (2.17)	R-34.8 (6.13)	R-21.8 (3.83)	0.046 (0.261)
R-16.4 (2.89)	R-38.9 (6.85)	R-24.7 (4.34)	0.041 (0.230)

Temperature Indices

	R4.1	R12.3	R16.4	
T_{i1}	0.27	0.41	0.46	Min T on sheathing, at fastener along studs
T_{i2}	0.23	0.45	0.52	Min T on sheathing, between studs and fasteners

Temperature indices listed for selected scenarios. All other scenarios to be interpolated.

Detail 5.1.29

Exterior and Interior Insulated 6" 1 5/8" Steel Stud (16" o.c.) Wall Assembly with High Compression Insulation and Through Insulation Steel Fasteners (12" o.c.) Supporting Cladding, Owens Corning ThermaFiber RainBarrier 45 Insulation and R-20 Batt Insulation in Stud Cavity – Clear Wall

Thermal Performance Indicators

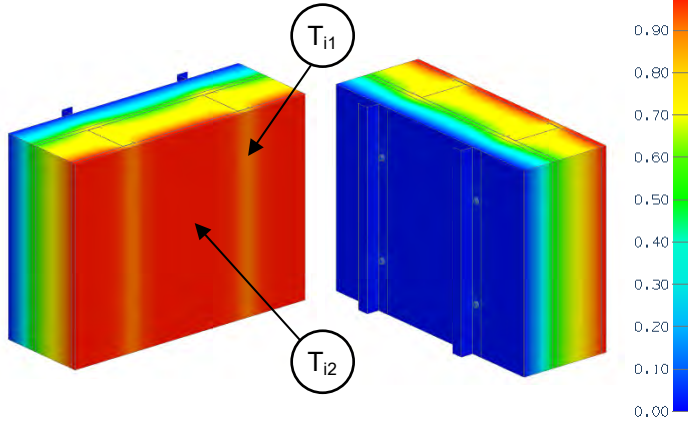

Assembly 1D (Nominal) R-Value	R_{1D}	R-22.5 (3.96 RSI) + exterior insulation
Transmittance / Resistance	U_o, R_o	"clear wall" U- and R-value
Surface Temperature Index	T_i	0 = exterior temperature 1 = interior temperature

View from Interior View from Exterior

Nominal (1D) vs. Assembly Performance Indicators

Exterior Insulation 1D R-Value (RSI)	R_{1D} ft ² ·hr·°F / Btu (m ² K / W)	R_o ft ² ·hr·°F / Btu (m ² K / W)	U_o Btu/ft ² ·hr ·°F (W/m ² K)
R-4.2 (0.74)	R-26.7 (4.70)	R-15.6 (2.75)	0.064 (0.363)
R-8.4 (1.48)	R-30.9 (5.44)	R-18.8 (3.31)	0.053 (0.302)
R-12.6 (2.22)	R-35.1 (6.18)	R-21.9 (3.86)	0.046 (0.259)
R-16.8 (2.96)	R-39.3 (6.92)	R-24.9 (4.39)	0.040 (0.228)

Temperature Indices

	R4.2	R12.6	R16.8	
T_{i1}	0.27	0.41	0.46	Min T on sheathing, at fastener along studs
T_{i2}	0.23	0.45	0.52	Min T on sheathing, between studs and fasteners

Temperature indices listed for selected scenarios. All other scenarios to be interpolated.

Detail 5.1.30

Exterior and Interior Insulated 6" x 1 5/8" Steel Stud (16" o.c.) Wall Assembly with High Compression Insulation and Through Insulation Steel Fasteners (12" o.c.) Supporting Cladding, Owens Corning ThermaFiber RainBarrier HC Max Insulation and R-22 Batt Insulation in Stud Cavity – Clear Wall

Thermal Performance Indicators

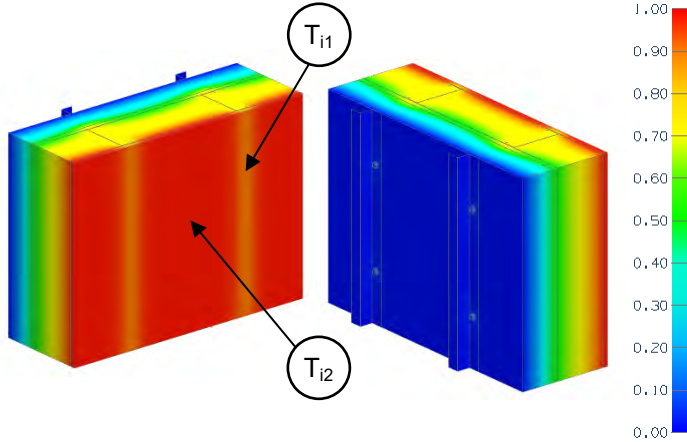

Assembly 1D (Nominal) R-Value	R_{1D}	R-24.5 (4.31 RSI) + exterior insulation
Transmittance / Resistance	U_o, R_o	"clear wall" U- and R-value
Surface Temperature Index	T_i	0 = exterior temperature 1 = interior temperature

View from Interior View from Exterior

Nominal (1D) vs. Assembly Performance Indicators

Exterior Insulation 1D R-Value (RSI)	R_{1D} ft ² ·hr·°F / Btu (m ² K / W)	R_o ft ² ·hr·°F / Btu (m ² K / W)	U_o Btu/ft ² ·hr ·°F (W/m ² K)
R-4.0 (0.70)	R-28.5 (5.02)	R-16.0 (2.81)	0.063 (0.355)
R-8.0 (1.41)	R-32.5 (5.72)	R-19.0 (3.35)	0.053 (0.299)
R-12.0 (2.11)	R-36.5 (6.43)	R-22.1 (3.89)	0.045 (0.257)
R-16.0 (2.82)	R-40.5 (7.13)	R-24.9 (4.39)	0.040 (0.228)

Temperature Indices

	R4	R12	R16	
T_{i1}	0.27	0.40	0.45	Min T on sheathing, at fastener along studs
T_{i2}	0.21	0.42	0.49	Min T on sheathing, between studs and fasteners

Temperature indices listed for selected scenarios. All other scenarios to be interpolated.

Detail 5.1.31

Exterior and Interior Insulated 6" x 1 5/8" Steel Stud (16" o.c.) Wall Assembly with High Compression Insulation and Through Insulation Steel Fasteners (12" o.c.) Supporting Cladding, Owens Corning ThermaFiber RainBarrier HC Plus 110 Exterior Insulation and R-22 Batt Insulation in Stud Cavity – Clear Wall

Thermal Performance Indicators

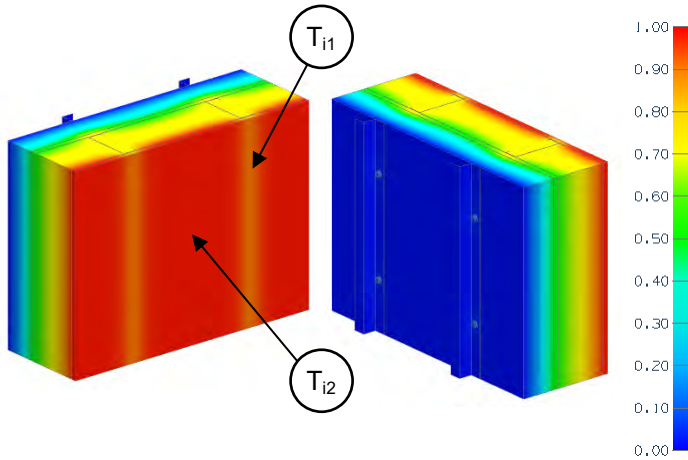

Assembly 1D (Nominal) R-Value	R_{1D}	R-24.5 (4.31 RSI) + exterior insulation
Transmittance / Resistance	U_o, R_o	"clear wall" U- and R-value
Surface Temperature Index	T_i	0 = exterior temperature 1 = interior temperature

View from Interior View from Exterior

Nominal (1D) vs. Assembly Performance Indicators

Exterior Insulation 1D R-Value (RSI)	R_{1D} ft ² ·hr·°F / Btu (m ² K / W)	R_o ft ² ·hr·°F / Btu (m ² K / W)	U_o Btu/ft ² ·hr ·°F (W/m ² K)
R-4.1 (0.72)	R-28.6 (5.04)	R-16.1 (2.83)	0.062 (0.354)
R-8.2 (1.44)	R-32.7 (5.76)	R-19.2 (3.37)	0.052 (0.296)
R-12.3 (2.17)	R-36.8 (6.48)	R-22.3 (3.92)	0.045 (0.255)
R-16.4 (2.89)	R-40.9 (7.20)	R-25.2 (4.43)	0.040 (0.226)

Temperature Indices

	R4.1	R12.3	R16.4	
T_{i1}	0.27	0.40	0.46	Min T on sheathing, at fastener along studs
T_{i2}	0.21	0.43	0.50	Min T on sheathing, between studs and fasteners

Temperature indices listed for selected scenarios. All other scenarios to be interpolated.

Detail 5.1.32

Exterior and Interior Insulated 6" x 1 5/8" Steel Stud (16" o.c.) Wall Assembly with High Compression Insulation and Through Insulation Steel Fasteners (12" o.c.) Supporting Cladding, Owens Corning ThermaFiber RainBarrier 45 Insulation and R-22 Batt Insulation in Stud Cavity – Clear Wall

Thermal Performance Indicators

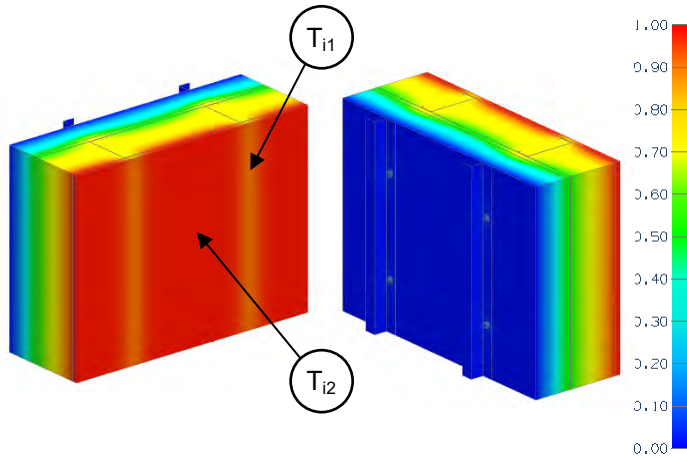

Assembly 1D (Nominal) R-Value	R_{1D}	R-24.5 (4.31 RSI) + exterior insulation
Transmittance / Resistance	U_o, R_o	"clear wall" U- and R-value
Surface Temperature Index	T_i	0 = exterior temperature 1 = interior temperature

View from Interior View from Exterior

Nominal (1D) vs. Assembly Performance Indicators

Exterior Insulation 1D R-Value (RSI)	R_{1D} ft ² ·hr·°F / Btu (m ² K / W)	R_o ft ² ·hr·°F / Btu (m ² K / W)	U_o Btu/ft ² ·hr ·°F (W/m ² K)
R-4.2 (0.74)	R-28.7 (5.05)	R-16.1 (2.84)	0.062 (0.352)
R-8.4 (1.48)	R-32.9 (5.79)	R-19.3 (3.40)	0.052 (0.294)
R-12.6 (2.22)	R-37.1 (6.53)	R-22.5 (3.95)	0.045 (0.253)
R-16.8 (2.96)	R-41.3 (7.27)	R-25.4 (4.48)	0.039 (0.223)

Temperature Indices

	R4.2	R12.6	R16.8	
T_{i1}	0.27	0.41	0.46	Min T on sheathing, at fastener along studs
T_{i2}	0.22	0.44	0.51	Min T on sheathing, between studs and fasteners

Temperature indices listed for selected scenarios. All other scenarios to be interpolated.

Detail 5.1.33

Exterior and Interior Insulated 6" x 1 5/8" Steel Stud (16" o.c.) Wall Assembly with High Compression Insulation and Through Insulation Steel Fasteners (12" o.c.) Supporting Cladding, Owens Corning ThermaFiber RainBarrier HC Max Insulation and R-24 Batt Insulation in Stud Cavity – Clear Wall

Thermal Performance Indicators

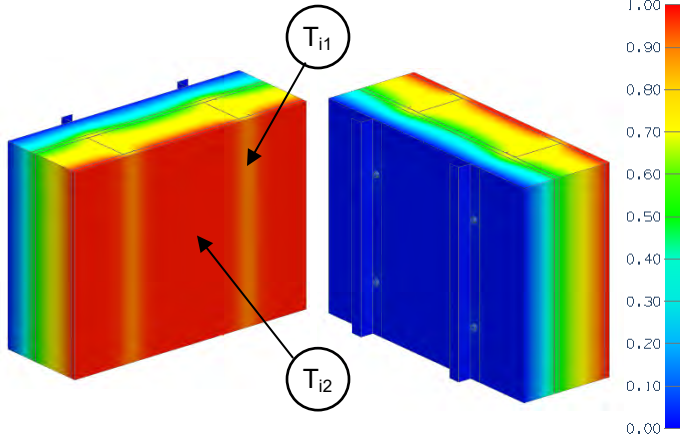

Assembly 1D (Nominal) R-Value	R_{1D}	R-26.4 (4.67 RSI) + exterior insulation
Transmittance / Resistance	U_o, R_o	"clear wall" U- and R-value
Surface Temperature Index	T_i	0 = exterior temperature 1 = interior temperature

View from Interior View from Exterior

Nominal (1D) vs. Assembly Performance Indicators

Exterior Insulation 1D R-Value (RSI)	R_{1D} ft ² ·hr·°F / Btu (m ² K / W)	R_o ft ² ·hr·°F / Btu (m ² K / W)	U_o Btu/ft ² ·hr ·°F (W/m ² K)
R-4.0 (0.70)	R-30.5 (5.37)	R-16.5 (2.90)	0.061 (0.345)
R-8.0 (1.41)	R-34.5 (6.08)	R-19.5 (3.43)	0.051 (0.291)
R-12.0 (2.11)	R-38.5 (6.78)	R-22.5 (3.97)	0.044 (0.252)
R-16.0 (2.82)	R-42.5 (7.48)	R-25.4 (4.47)	0.039 (0.224)

Temperature Indices

	R4	R12	R16	
T_{i1}	0.26	0.40	0.45	Min T on sheathing, at fastener along studs
T_{i2}	0.20	0.41	0.48	Min T on sheathing, between studs and fasteners

Temperature indices listed for selected scenarios. All other scenarios to be interpolated.

Detail 5.1.34

Exterior and Interior Insulated 6" x 1 5/8" Steel Stud (16" o.c.) Wall Assembly with High Compression Insulation and Through Insulation Steel Fasteners (12" o.c.) Supporting Cladding, Owens Corning ThermaFiber RainBarrier HC Plus 110 Exterior Insulation and R-24 Batt Insulation in Stud Cavity – Clear Wall

Thermal Performance Indicators

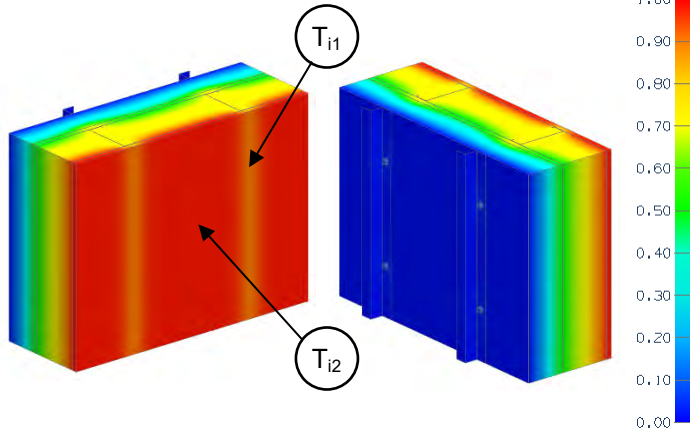

Assembly 1D (Nominal) R-Value	R_{1D}	R-26.4 (4.67 RSI) + exterior insulation
Transmittance / Resistance	U_o, R_o	"clear wall" U- and R-value
Surface Temperature Index	T_i	0 = exterior temperature 1 = interior temperature

View from Interior View from Exterior

Nominal (1D) vs. Assembly Performance Indicators

Exterior Insulation 1D R-Value (RSI)	R_{1D} ft ² ·hr·°F / Btu (m ² K / W)	R_o ft ² ·hr·°F / Btu (m ² K / W)	U_o Btu/ft ² ·hr ·°F (W/m ² K)
R-4.1 (0.72)	R-30.6 (5.39)	R-16.5 (2.91)	0.060 (0.344)
R-8.2 (1.44)	R-34.7 (6.11)	R-19.6 (3.46)	0.051 (0.289)
R-12.3 (2.17)	R-38.8 (6.83)	R-22.7 (4.01)	0.044 (0.250)
R-16.4 (2.89)	R-42.9 (7.55)	R-25.6 (4.51)	0.039 (0.222)

Temperature Indices

	R4.1	R12.3	R16.4	
T_{i1}	0.27	0.40	0.45	Min T on sheathing, at fastener along studs
T_{i2}	0.20	0.42	0.48	Min T on sheathing, between studs and fasteners

Temperature indices listed for selected scenarios. All other scenarios to be interpolated.

Detail 5.1.35

Exterior and Interior Insulated 6" x 1 5/8" Steel Stud (16" o.c.) Wall Assembly with High Compression Insulation and Through Insulation Steel Fasteners (12" o.c.) Supporting Cladding, Owens Corning ThermaFiber RainBarrier 45 Insulation and R-24 Batt Insulation in Stud Cavity – Clear Wall

Thermal Performance Indicators

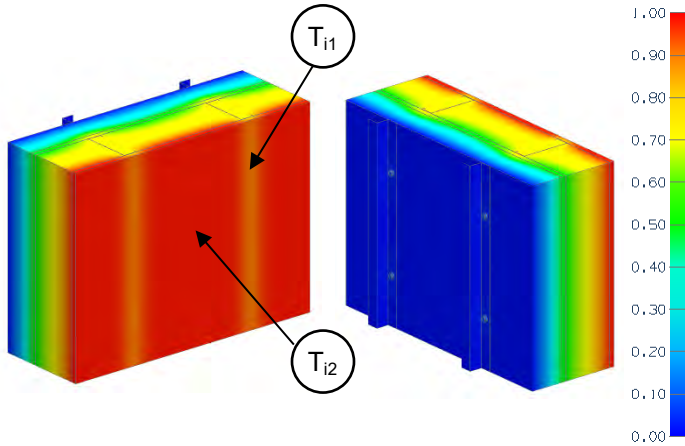

Assembly 1D (Nominal) R-Value	R_{1D}	R-26.4 (4.67 RSI) + exterior insulation
Transmittance / Resistance	U_o, R_o	"clear wall" U- and R-value
Surface Temperature Index	T_i	0 = exterior temperature 1 = interior temperature

View from Interior View from Exterior

Nominal (1D) vs. Assembly Performance Indicators

Exterior Insulation 1D R-Value (RSI)	R_{1D} ft ² ·hr·°F / Btu (m ² K / W)	R_o ft ² ·hr·°F / Btu (m ² K / W)	U_o Btu/ft ² ·hr ·°F (W/m ² K)
R-4.2 (0.74)	R-30.7 (5.41)	R-16.6 (2.93)	0.060 (0.342)
R-8.4 (1.48)	R-34.9 (6.15)	R-19.8 (3.48)	0.051 (0.287)
R-12.6 (2.22)	R-39.1 (6.89)	R-22.9 (4.04)	0.044 (0.248)
R-16.8 (2.96)	R-43.3 (7.63)	R-25.9 (4.56)	0.039 (0.219)

Temperature Indices

	R4.2	R12.6	R16.8	
T_{i1}	0.27	0.40	0.45	Min T on sheathing, at fastener along studs
T_{i2}	0.21	0.42	0.49	Min T on sheathing, between studs and fasteners

Temperature indices listed for selected scenarios. All other scenarios to be interpolated.

Detail 5.1.36

Exterior and Interior Insulated 6" x 1 5/8" Steel Stud (16" o.c.) Wall Assembly with Knight CI-System (8" o.c.) and 1 1/2" Spray Foam (R-9.8) in Stud Cavity – Clear Wall

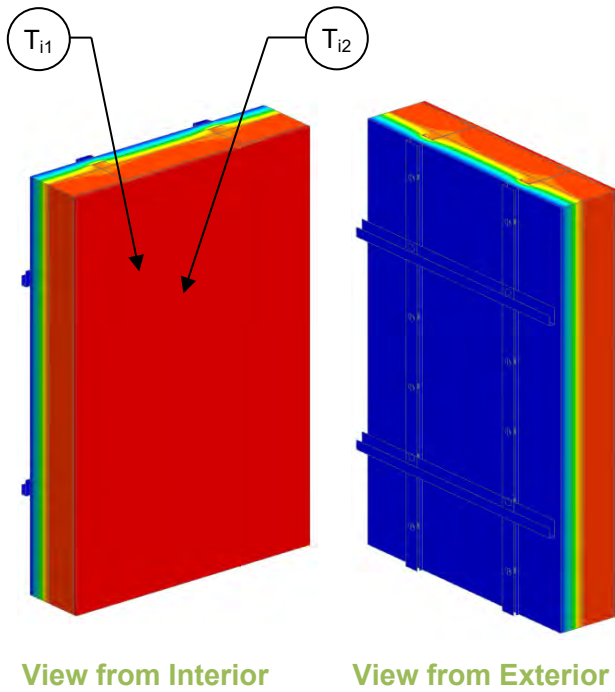

Thermal Performance Indicators

Assembly 1D (Nominal) R-Value	R_{1D}	R-12.6 (2.22 RSI) + exterior insulation
Transmittance / Resistance without Anomaly	U_o, R_o	"clear wall" U- and R-value
Surface Temperature Index ¹	T_i	0 = exterior temperature 1 = interior temperature

¹Assumptions and limitations for surface temperatures identified in ASHRAE 1365-RP

Nominal (1D) vs. Assembly Performance Indicators

Exterior Insulation 1D R-Value (RSI)	R_{1D} ft ² ·hr·°F / Btu (m ² K / W)	R_o ft ² ·hr·°F / Btu (m ² K / W)	U_o Btu/ft ² ·hr ·°F (W/m ² K)
R-10.1 (1.78)	R-22.7 (4.00)	R-18.0 (3.17)	0.056 (0.32)
R-19.0 (3.35)	R-31.6 (5.57)	R-25.6 (4.51)	0.039 (0.22)

Temperature Indices

	R10	R19	
T_{i1}	0.89	0.92	Min T on Spray Foam, at fasteners along studs
T_{i2}	0.90	0.93	Max T on Spray Foam, between studs

Detail 5.1.37

Exterior and Interior Insulated 6" x 1 5/8" Steel Stud (16" o.c.) Wall Assembly with Knight CI-System (16" o.c.) and 1 1/2" Spray Foam (R-9.8) in Stud Cavity – Clear Wall

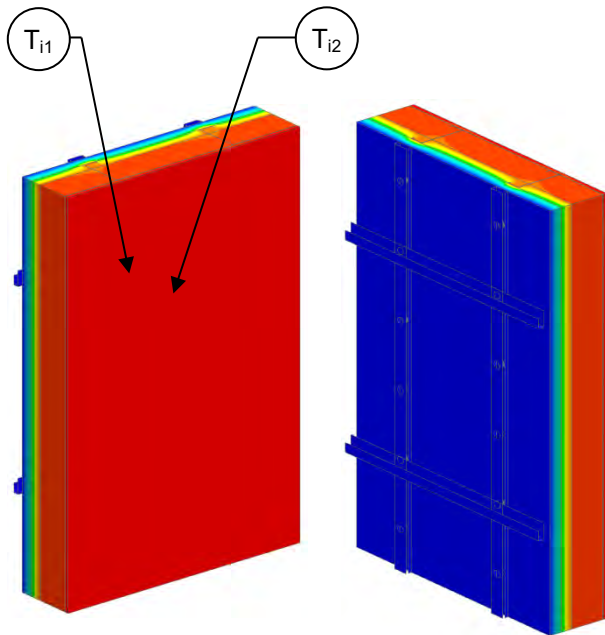

View from Interior

View from Exterior

Thermal Performance Indicators

Assembly 1D (Nominal) R-Value	R_{1D}	R-12.6 (2.22 RSI) + exterior insulation
Transmittance / Resistance without Anomaly	U_o, R_o	"clear wall" U- and R-value
Surface Temperature Index ¹	T_i	0 = exterior temperature 1 = interior temperature

¹Assumptions and limitations for surface temperatures identified in ASHRAE 1365-RP

Nominal (1D) vs. Assembly Performance Indicators

Exterior Insulation 1D R-Value (RSI)	R_{1D} ft ² ·hr·°F / Btu (m ² K / W)	R_o ft ² ·hr·°F / Btu (m ² K / W)	U_o Btu/ft ² ·hr ·°F (W/m ² K)
R-10.1 (1.78)	R-22.7 (4.00)	R-18.8 (3.31)	0.053 (0.30)
R-19.0 (3.35)	R-31.6 (5.57)	R-27.0 (4.76)	0.037 (0.21)

Temperature Indices

	R10	R19	
T_{i1}	0.89	0.92	Min T on Spray Foam, at fasteners along studs
T_{i2}	0.90	0.93	Max T on Spray Foam, between studs

Detail 5.1.38

Exterior Insulated 6" x 1 5/8" Steel Stud (16" o.c.) Wall Assembly with Knight CI-System (8" o.c.) – Clear Wall

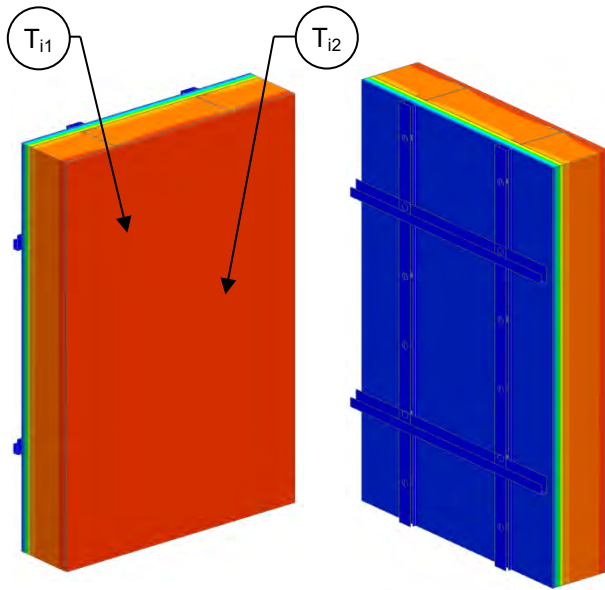

Thermal Performance Indicators



Assembly 1D (Nominal) R-Value	R_{1D}	R-2.8 (0.49 RSI) + exterior insulation
Transmittance / Resistance without Anomaly	U_o, R_o	"clear wall" U- and R-value
Surface Temperature Index ¹	T_i	0 = exterior temperature 1 = interior temperature

¹Assumptions and limitations for surface temperatures identified in ASHRAE 1365-RP

View from Interior

View from Exterior

Nominal (1D) vs. Assembly Performance Indicators

Exterior Insulation 1D R-Value (RSI)	R_{1D} ft ² ·hr·°F / Btu (m ² K / W)	R_o ft ² ·hr·°F / Btu (m ² K / W)	U_o Btu/ft ² ·hr ·°F (W/m ² K)
R-10.1 (1.78)	R-12.9 (2.27)	R-12.5 (2.20)	0.080 (0.45)
R-19.0 (3.35)	R-21.8 (3.84)	R-20.7 (3.65)	0.048 (0.27)

Temperature Indices

	R10	R19	
T_{i1}	0.61	0.68	Min T on exterior insulation, around fasteners
T_{i2}	0.85	0.91	Max T on exterior insulation, along studs

Detail 5.1.39

Exterior Insulated 3 5/8" x 1 5/8" Steel Stud (16" o.c.) Wall Assembly with R-TEC CI Bracket System Supporting Vertical Sub-girts – Clear Wall

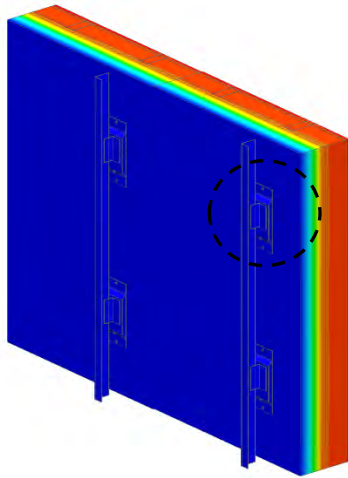

View from Exterior

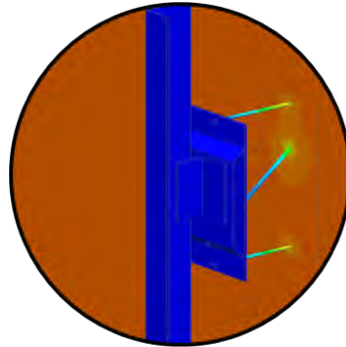

View of Bracket

Thermal Performance Indicators



Assembly 1D (Nominal) R-Value	R_{1D}	R-3.2 (0.56 RSI) + exterior insulation
Transmittance / Resistance	U_o, R_o	"Clear wall" U_o and R-value

Nominal (1D) vs. Assembly Performance Indicators

Exterior Insulation 1D R-Value (RSI)	R_{1D} ft ² ·hr·°F / Btu (m ² K / W)	24" Vertical Clip Spacing		36" Vertical Clip Spacing		48" Vertical Clip Spacing	
		R_o ft ² ·hr·°F / Btu (m ² K / W)	U_o Btu/ft ² ·hr ·°F (W/m ² K)	R_o ft ² ·hr·°F / Btu (m ² K / W)	U_o Btu/ft ² ·hr ·°F (W/m ² K)	R_o ft ² ·hr·°F / Btu (m ² K / W)	U_o Btu/ft ² ·hr ·°F (W/m ² K)
12.6 (2.22)	15.8 (2.78)	R-14.7 (2.59)	0.068 (0.387)	R-15.0 (2.65)	0.067 (0.378)	R-15.2 (2.68)	0.066 (0.374)
16.8 (2.96)	20.0 (3.52)	R-18.7 (3.29)	0.053 (0.304)	R-19.2 (3.38)	0.052 (0.296)	R-19.4 (3.42)	0.051 (0.292)
21.0 (3.70)	24.2 (4.26)	R-22.7 (3.99)	0.044 (0.250)	R-23.1 (4.07)	0.043 (0.246)	R-23.5 (4.13)	0.043 (0.242)
25.2 (4.44)	28.4 (5.00)	R-26.5 (4.67)	0.038 (0.214)	R-27.3 (4.8)	0.037 (0.208)	R-27.6 (4.87)	0.036 (0.206)

Detail 5.1.40

Exterior and Interior Insulated 3 5/8" x 1 5/8" Steel Stud (16" o.c.) Wall Assembly with R-TEC CI Bracket System Supporting Vertical Sub-girts and R-13 Batt Insulation in Stud Cavity – Clear Wall

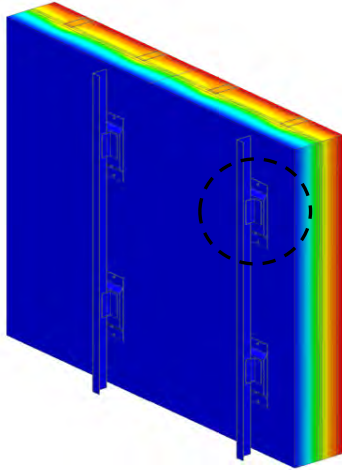

View from Exterior

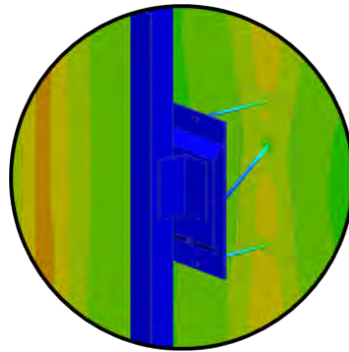

View of Bracket

Thermal Performance Indicators



Assembly 1D (Nominal) R-Value	R_{1D}	R-15.3 (2.69 RSI) + exterior insulation
Transmittance / Resistance	U_o, R_o	"Clear wall" U- and R-value

Nominal (1D) vs. Assembly Performance Indicators Clear Wall – With Fiberglass Batt Insulation in Stud Cavity

Exterior Insulation 1D R-Value (RSI)	R_{1Db} ft ² ·hr·°F / Btu (m ² K / W)	24" Vertical Clip Spacing		36" Vertical Clip Spacing		48" Vertical Clip Spacing	
		R_o ft ² ·hr·°F / Btu (m ² K / W)	U_o Btu/ft ² ·hr ·°F (W/m ² K)	R_o ft ² ·hr·°F / Btu (m ² K / W)	U_o Btu/ft ² ·hr ·°F (W/m ² K)	R_o ft ² ·hr·°F / Btu (m ² K / W)	U_o Btu/ft ² ·hr ·°F (W/m ² K)
12.6 (2.22)	27.9 (4.91)	R-21.3 (3.74)	0.047 (0.267)	R-21.6 (3.80)	0.046 (0.263)	R-21.8 (3.84)	0.046 (0.261)
16.8 (2.96)	32.1 (5.65)	R-25.4 (4.47)	0.039 (0.224)	R-25.8 (4.54)	0.039 (0.220)	R-26.1 (4.59)	0.038 (0.218)
21.0 (3.70)	36.3 (6.39)	R-29.3 (5.16)	0.034 (0.194)	R-29.9 (5.27)	0.033 (0.190)	R-30.0 (5.29)	0.033 (0.189)
25.2 (4.44)	40.5 (7.13)	R-33.4 (5.88)	0.030 (0.170)	R-33.7 (5.93)	0.030 (0.169)	R-34.2 (6.02)	0.029 (0.166)

Detail 5.1.41

Exterior Insulated 3 5/8" x 1 5/8" Steel Stud (16" o.c.) Wall Assembly with Thermally Broken ISO Clip System Supporting Vertical Sub-girts – Clear Wall

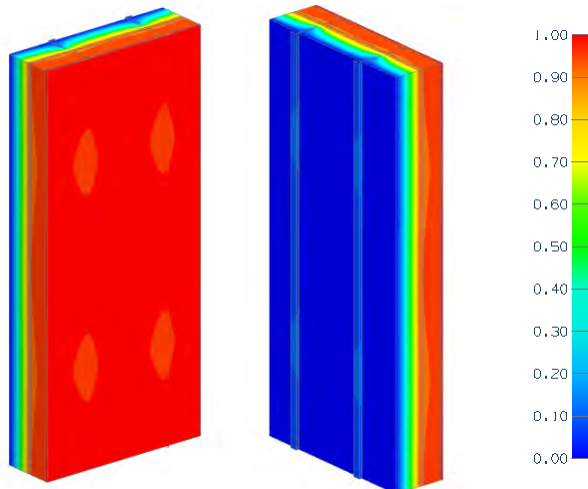

View from Interior

View from Exterior

Thermal Performance Indicators

Assembly 1D (Nominal) R-Value	R_{1D}	R-3.2 (0.56 RSI) + exterior insulation
Transmittance / Resistance	U_o, R_o	“Clear wall” U- and R-value

Nominal (1D) vs. Assembly Performance Indicators

Exterior Insulation 1D R-Value (RSI)	R_{1D} ft ² ·hr·°F / Btu (m ² K / W)	24" Vertical Clip Spacing		36" Vertical Clip Spacing		48" Vertical Clip Spacing	
		R_o ft ² ·hr·°F / Btu (m ² K / W)	U_o Btu/ft ² ·hr·°F (W/m ² K)	R_o ft ² ·hr·°F / Btu (m ² K / W)	U_o Btu/ft ² ·hr·°F (W/m ² K)	R_o ft ² ·hr·°F / Btu (m ² K / W)	U_o Btu/ft ² ·hr·°F (W/m ² K)
16.8 (2.96)	20 (3.52)	R-14.3 (2.51)	0.070 (0.398)	R-15.1 (2.66)	0.066 (0.376)	R-15.6 (2.75)	0.064 (0.363)
21.0 (3.70)	24.2 (4.26)	R-15.8 (2.78)	0.063 (0.360)	R-16.7 (2.94)	0.060 (0.340)	R-17.4 (3.06)	0.058 (0.327)
25.2 (4.44)	28.4 (5.00)	R-17.0 (2.99)	0.059 (0.334)	R-18.0 (3.18)	0.055 (0.315)	R-18.8 (3.31)	0.053 (0.302)

Detail 5.1.42

Exterior Insulated 3 5/8" x 1 5/8" Steel Stud (16" o.c.) Wall Assembly with Thermally Broken ISO Clip System Supporting Horizontal Subgirts – Clear Wall

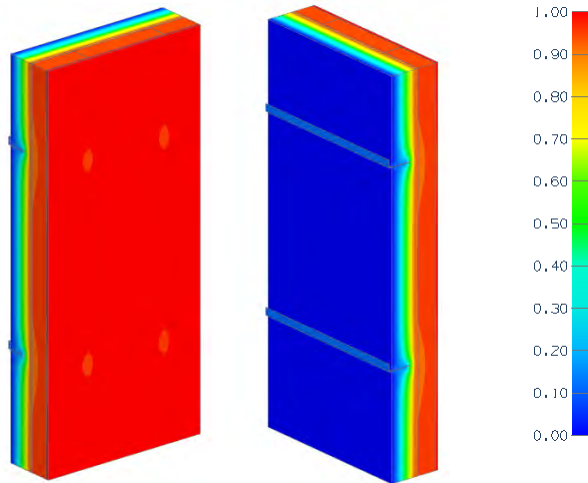

View from Interior

View from Exterior

Thermal Performance Indicators

Assembly 1D (Nominal) R-Value	R_{1D}	R-3.2 (0.56 RSI) + exterior insulation
Transmittance / Resistance	U_o , R_o	“Clear wall” U- and R-value

Nominal (1D) vs. Assembly Performance Indicators

Stud Spacing	Exterior Insulation 1D R-Value (RSI)	R_{1D} ft ² ·hr·°F / Btu (m ² K / W)	24" Vertical Clip Spacing		36" Vertical Clip Spacing		48" Vertical Clip Spacing		60" Vertical Clip Spacing	
			R_o ft ² ·hr·°F / Btu (m ² K / W)	U_o Btu/ft ² ·hr·°F (W/m ² K)	R_o ft ² ·hr·°F / Btu (m ² K / W)	U_o Btu/ft ² ·hr·°F (W/m ² K)	R_o ft ² ·hr·°F / Btu (m ² K / W)	U_o Btu/ft ² ·hr·°F (W/m ² K)	R_o ft ² ·hr·°F / Btu (m ² K / W)	U_o Btu/ft ² ·hr·°F (W/m ² K)
16" o.c.	16.8 (2.96)	20 (3.52)	R-15.1 (2.65)	0.066 (0.377)	R-16.4 (2.88)	0.061 (0.347)	R-17.2 (3.02)	0.058 (0.331)	R-17.7 (3.12)	0.057 (0.321)
	21.0 (3.70)	24.2 (4.26)	R-16.9 (2.98)	0.059 (0.335)	R-18.7 (3.3)	0.053 (0.303)	R-19.8 (3.5)	0.050 (0.286)	R-20.6 (3.64)	0.048 (0.275)
	25.2 (4.44)	28.4 (5.00)	R-18.5 (3.26)	0.054 (0.307)	R-20.9 (3.67)	0.048 (0.273)	R-22.3 (3.93)	0.045 (0.254)	R-23.4 (4.12)	0.043 (0.243)
24" o.c.	16.8 (2.96)	20 (3.52)	R-16.0 (2.82)	0.062 (0.354)	R-17.1 (3.01)	0.058 (0.332)	R-17.8 (3.13)	0.056 (0.319)	R-18.2 (3.21)	0.055 (0.312)
	21.0 (3.70)	24.2 (4.26)	R-18.1 (3.19)	0.055 (0.314)	R-19.7 (3.47)	0.051 (0.289)	R-20.7 (3.64)	0.048 (0.275)	R-21.3 (3.75)	0.047 (0.266)
	25.2 (4.44)	28.4 (5.00)	R-19.9 (3.50)	0.050 (0.286)	R-22.0 (3.87)	0.045 (0.258)	R-23.3 (4.10)	0.043 (0.244)	R-24.2 (4.26)	0.041 (0.235)

Detail 5.1.43

Exterior and Interior Insulated 3 5/8" x 1 5/8" Steel Stud (16" o.c.) Wall Assembly with Thermally Broken ISO Clip System Supporting Vertical Sub-girts and R-12 Batt Insulation in Stud Cavity – Clear Wall

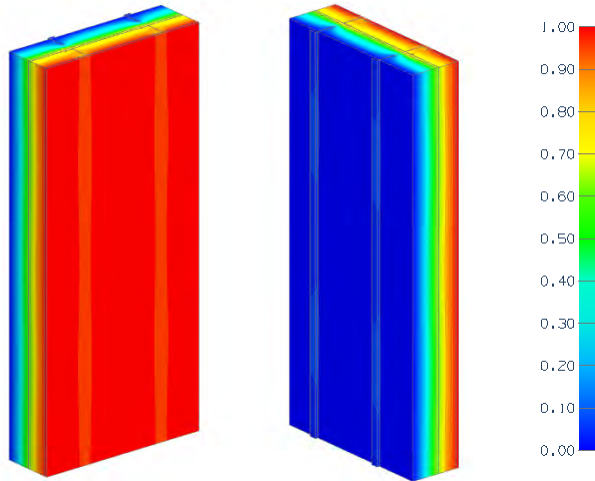

View from Interior

View from Exterior

Thermal Performance Indicators

Assembly 1D (Nominal) R-Value	R _{1D}	R-14.3 (2.52 RSI) + exterior insulation
Transmittance / Resistance	U _o , R _o	“Clear wall” U- and R-value

Nominal (1D) vs. Assembly Performance Indicators

Clear Wall – With Fiberglass Batt Insulation in Stud Cavity

Exterior Insulation 1D R-Value (RSI)	R _{1D} ft ² ·hr·°F / Btu (m ² K / W)	24" Vertical Clip Spacing		36" Vertical Clip Spacing		48" Vertical Clip Spacing		60" Vertical Clip Spacing	
		R _o ft ² ·hr·°F / Btu (m ² K / W)	U _o Btu/ft ² ·hr·°F (W/m ² K)	R _o ft ² ·hr·°F / Btu (m ² K / W)	U _o Btu/ft ² ·hr·°F (W/m ² K)	R _o ft ² ·hr·°F / Btu (m ² K / W)	U _o Btu/ft ² ·hr·°F (W/m ² K)	R _o ft ² ·hr·°F / Btu (m ² K / W)	U _o Btu/ft ² ·hr·°F (W/m ² K)
16.8 (2.96)	31.1 (5.48)	R-19.6 (3.46)	0.051 (0.289)	R-20.7 (3.64)	0.048 (0.274)	R-21.4 (3.76)	0.047 (0.266)	R-21.6 (3.80) ¹	0.046 (0.263) ¹
21.0 (3.70)	35.3 (6.22)	R-21.0 (3.7)	0.048 (0.270)	R-22.2 (3.92)	0.045 (0.255)	R-23.0 (4.05)	0.043 (0.247)	R-23.2 (4.08) ¹	0.043 (0.245) ¹
25.2 (4.44)	39.5 (6.96)	R-22.2 (3.91)	0.045 (0.255)	R-23.5 (4.14)	0.043 (0.241)	R-24.4 (4.29)	0.041 (0.233)	R-24.7 (4.35) ¹	0.040 (0.230) ¹

¹ Values were interpolated and not explicitly modelled

Detail 5.1.44

Exterior and Interior Insulated 3 5/8" x 1 5/8" Steel Stud (16" o.c.) Wall Assembly with Thermally Broken ISO Clip System Supporting Horizontal Sub-girts and R-12 Batt Insulation in Stud Cavity – Clear Wall

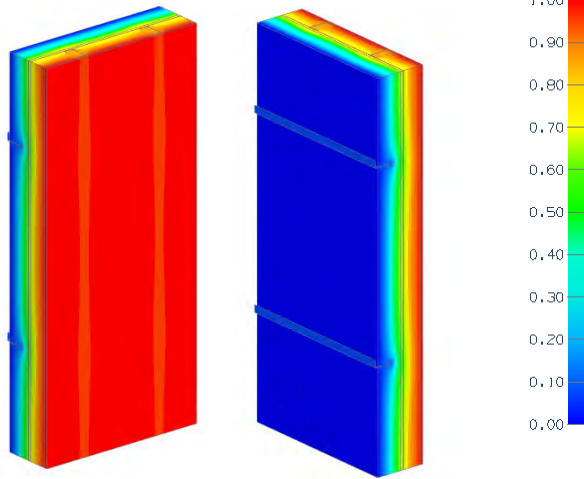

View from Interior

View from Exterior

Thermal Performance Indicators

Assembly 1D (Nominal) R-Value	R_{1D}	R-14.3 (2.52 RSI) + exterior insulation
Transmittance / Resistance	U_o, R_o	“Clear wall” U- and R-value

Nominal (1D) vs. Assembly Performance Indicators

Stud Spacing	Exterior Insulation 1D R-Value (RSI)	R_{1D} ft ² ·hr·°F / Btu (m ² K / W)	24" Vertical Clip Spacing		36" Vertical Clip Spacing		48" Vertical Clip Spacing		60" Vertical Clip Spacing	
			R_o ft ² ·hr·°F / Btu (m ² K / W)	U_o Btu/ft ² ·hr ·°F (W/m ² K)	R_o ft ² ·hr·°F / Btu (m ² K / W)	U_o Btu/ft ² ·hr ·°F (W/m ² K)	R_o ft ² ·hr·°F / Btu (m ² K / W)	U_o Btu/ft ² ·hr ·°F (W/m ² K)	R_o ft ² ·hr·°F / Btu (m ² K / W)	U_o Btu/ft ² ·hr ·°F (W/m ² K)
16" o.c.	16.8 (2.96)	31.1 (5.48)	R-20.8 (3.66)	0.048 (0.273)	R-22.3 (3.92)	0.045 (0.255)	R-23.1 (4.08)	0.043 (0.245)	R-23.8 (4.19)	0.042 (0.239)
	21.0 (3.70)	35.3 (6.22)	R-22.6 (3.98)	0.044 (0.251)	R-24.6 (4.34)	0.041 (0.231)	R-25.9 (4.55)	0.039 (0.220)	R-26.7 (4.71)	0.037 (0.212)
	25.2 (4.44)	39.5 (6.96)	R-24.2 (4.26)	0.041 (0.235)	R-26.8 (4.71)	0.037 (0.212)	R-28.4 (5.00)	0.035 (0.200)	R-29.5 (5.20)	0.034 (0.192)
24" o.c.	16.8 (2.96)	31.1 (5.48)	R-23.0 (4.04)	0.044 (0.247)	R-24.3 (4.28)	0.041 (0.234)	R-25.1 (4.42)	0.040 (0.226)	R-25.6 (4.51)	0.039 (0.222)
	21.0 (3.70)	35.3 (6.22)	R-25.0 (4.40)	0.040 (0.227)	R-26.8 (4.73)	0.037 (0.211)	R-28.0 (4.93)	0.036 (0.203)	R-28.7 (5.06)	0.035 (0.198)
	25.2 (4.44)	39.5 (6.96)	R-26.8 (4.71)	0.037 (0.212)	R-29.2 (5.14)	0.034 (0.195)	R-30.6 (5.40)	0.033 (0.185)	R-31.7 (5.58)	0.032 (0.179)

Detail 5.1.45

Exterior Insulated 3 5/8" x 1 5/8" Steel Stud (16" o.c.) Wall Assembly with Thermally Broken ISO Clip System (16" o.c.) Supporting Horizontal and Vertical Sub-girts – Clear Wall

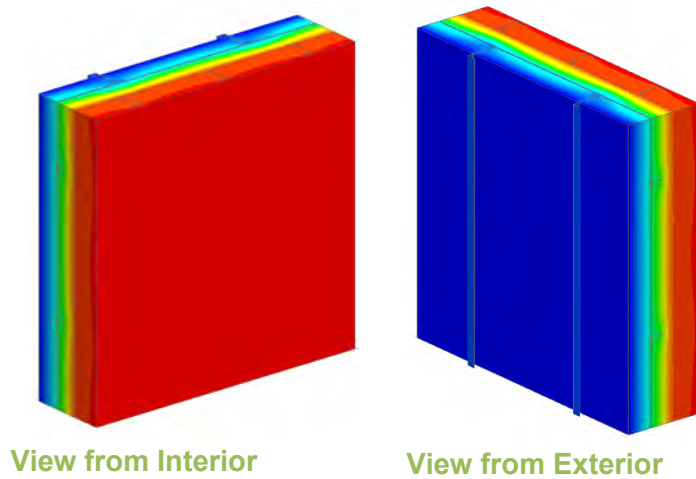

Thermal Performance Indicators

Assembly 1D (Nominal) R-Value	R_{1D}	R-3.2 (0.56 RSI) + insulation
Transmittance / Resistance without Anomaly	U_o, R_o	"clear field" U- and R-value, without roof anchor
Transmittance / Resistance	U, R	U- and R-values for overall assembly
Surface Temperature Index ¹	T_i	0 = exterior temperature 1 = interior temperature

¹Assumptions and limitations for surface temperatures identified in ASHRAE 1365-RP

Nominal (1D) vs. Assembly Performance Indicators

Vertical Girt Spacing	Base Layer Exterior Insulation 1D R-Value (RSI)	Outer Layer Exterior Insulation 1D R-Value (RSI)	R_{1D} ft ² ·hr·°F / Btu (m ² K / W)	24" Vertical Clip Spacing		40" Vertical Clip Spacing		60" Vertical Clip Spacing	
				R_o ft ² ·hr·°F / Btu (m ² K / W)	U_o Btu/ft ² ·hr ·°F (W/m ² K)	R_o ft ² ·hr·°F / Btu (m ² K / W)	U_o Btu/ft ² ·hr ·°F (W/m ² K)	R_o ft ² ·hr·°F / Btu (m ² K / W)	U_o Btu/ft ² ·hr ·°F (W/m ² K)
24"	R-16.8 (2.96)	R-12.6 (2.22)	R-32.6 (5.74)	R-21.9 (3.85)	0.046 (0.26)	R-23.9 (4.22)	0.042 (0.24)	R-25.2 (4.43)	0.040 (0.23)
	R-16.8 (2.96)	R-16.8 (2.96)	R-36.8 (6.48)	R-23.1 (4.07)	0.043 (0.25)	R-25.3 (4.45)	0.040 (0.23)	R-26.6 (4.68)	0.038 (0.21)
40"	R-16.8 (2.96)	R-12.6 (2.22)	R-32.6 (5.74)	R-24.1 (4.24)	0.042 (0.24)	R-26.0 (4.59)	0.038 (0.22)	R-27.2 (4.79)	0.037 (0.21)
	R-16.8 (2.96)	R-16.8 (2.96)	R-36.8 (6.48)	R-26.0 (4.58)	0.038 (0.22)	R-28.1 (4.96)	0.036 (0.20)	R-29.4 (5.18)	0.034 (0.19)
60"	R-16.8 (2.96)	R-12.6 (2.22)	R-32.6 (5.74)	R-25.5 (4.50)	0.039 (0.22)	R-27.5 (4.85)	0.036 (0.21)	R-28.6 (5.04)	0.035 (0.20)
	R-16.8 (2.96)	R-16.8 (2.96)	R-36.8 (6.48)	R-28.1 (4.95)	0.036 (0.20)	R-30.2 (5.33)	0.033 (0.19)	R-31.2 (5.49)	0.032 (0.18)

Detail 5.1.46

Exterior Insulated 3 5/8" x 1 5/8" Steel Stud (16" o.c.) Wall Assembly with Thermally Broken ISO Clip System (32" o.c.) Supporting Horizontal and Vertical Sub-girts – Clear Wall

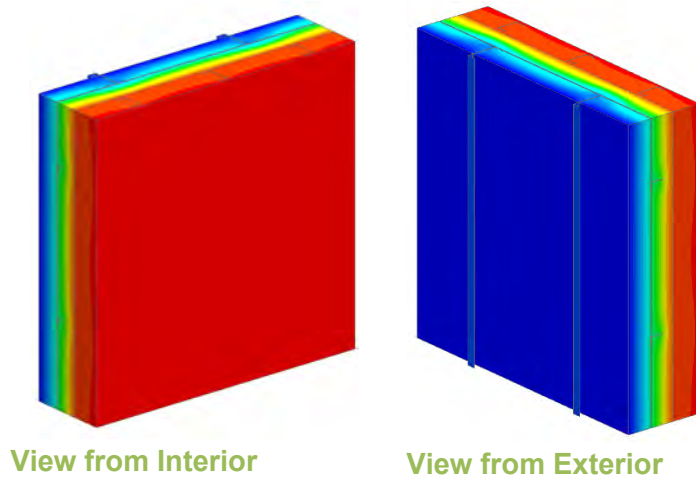

Thermal Performance Indicators

Assembly 1D (Nominal) R-Value	R_{1D}	R-3.2 (0.56 RSI) + insulation
Transmittance / Resistance without Anomaly	U_o, R_o	"clear field" U- and R-value, without roof anchor
Transmittance / Resistance	U, R	U- and R-values for overall assembly
Surface Temperature Index ¹	T_i	0 = exterior temperature 1 = interior temperature

¹Assumptions and limitations for surface temperatures identified in ASHRAE 1365-RP

Nominal (1D) vs. Assembly Performance Indicators

Vertical Girt Spacing	Base Layer Exterior Insulation 1D R-Value (RSI)	Outer Layer Exterior Insulation 1D R-Value (RSI)	R_{1D} ft ² ·hr·°F / Btu (m ² K / W)	24" Vertical Clip Spacing		40" Vertical Clip Spacing		60" Vertical Clip Spacing	
				R_o ft ² ·hr·°F / Btu (m ² K / W)	U_o Btu/ft ² ·hr·°F (W/m ² K)	R_o ft ² ·hr·°F / Btu (m ² K / W)	U_o Btu/ft ² ·hr·°F (W/m ² K)	R_o ft ² ·hr·°F / Btu (m ² K / W)	U_o Btu/ft ² ·hr·°F (W/m ² K)
24"	R-16.8 (2.96)	R-12.6 (2.22)	R-32.6 (5.74)	R-23.9 (4.21)	0.042 (0.24)	R-25.6 (4.50)	0.039 (0.22)	R-26.4 (4.65)	0.038 (0.22)
	R-16.8 (2.96)	R-16.8 (2.96)	R-36.8 (6.48)	R-25.2 (4.44)	0.040 (0.23)	R-27.0 (4.76)	0.037 (0.21)	R-27.9 (4.92)	0.036 (0.20)
40"	R-16.8 (2.96)	R-12.6 (2.22)	R-32.6 (5.74)	R-25.9 (4.56)	0.039 (0.22)	R-27.9 (4.91)	0.036 (0.20)	R-28.2 (4.97)	0.035 (0.20)
	R-16.8 (2.96)	R-16.8 (2.96)	R-36.8 (6.48)	R-27.9 (4.91)	0.036 (0.20)	R-30.0 (5.29)	0.033 (0.19)	R-30.5 (5.37)	0.033 (0.19)
60"	R-16.8 (2.96)	R-12.6 (2.22)	R-32.6 (5.74)	R-27.2 (4.79)	0.037 (0.21)	R-28.6 (5.04)	0.035 (0.20)	R-29.4 (5.17)	0.034 (0.19)
	R-16.8 (2.96)	R-16.8 (2.96)	R-36.8 (6.48)	R-29.8 (5.25)	0.034 (0.19)	R-31.4 (5.52)	0.032 (0.18)	R-32.2 (5.67)	0.031 (0.18)

Detail 5.1.47

Exterior Insulated 3 5/8" x 1 5/8" Steel Stud (16" o.c.) Wall Assembly with Nvelope – NV1 Clip System Supporting Cladding – Clear Wall

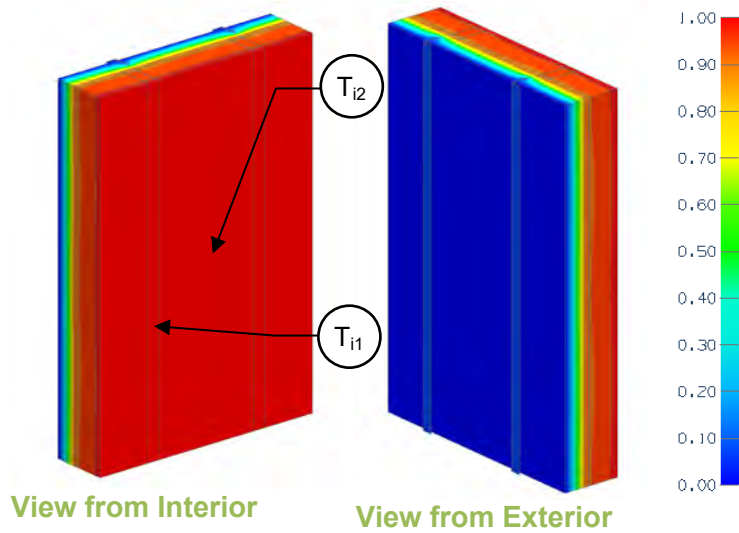

Thermal Performance Indicators

Assembly 1D (Nominal) R-Value	R_{1D}	R-3.2 (0.56 RSI) + exterior insulation
Transmittance / Resistance	U_o, R_o	"clear wall" U- and R-value
Surface Temperature Index ¹	T_i	0 = exterior temperature 1 = interior temperature

¹Assumptions and limitations for surface temperatures identified in ASHRAE 1365-RP

Nominal (1D) vs. Assembly Performance Indicators

Exterior Insulation 1D R-Value (RSI)	R_{1D} ft ² ·hr·°F / Btu (m ² K / W)	24" Vertical Spacing		36" Vertical Spacing		48" Vertical Spacing	
		R_o ft ² ·hr·°F / Btu (m ² K / W)	U_o Btu/ft ² ·hr·°F (W/m ² K)	R_o ft ² ·hr·°F / Btu (m ² K / W)	U_o Btu/ft ² ·hr·°F (W/m ² K)	R_o ft ² ·hr·°F / Btu (m ² K / W)	U_o Btu/ft ² ·hr·°F (W/m ² K)
R-12.6 (2.22)	R-15.8 (2.78)	R-12.6 (2.22)	0.079 (0.45)	R-13.3 (2.34)	0.075 (0.43)	R-13.7 (2.42)	0.073 (0.41)
R-16.8 (2.96)	R-20.0 (3.52)	R-14.9 (2.63)	0.067 (0.38)	R-16.1 (2.83)	0.062 (0.35)	R-16.8 (2.96)	0.059 (0.34)
R-21.0 (3.70)	R-24.2 (4.26)	R-16.7 (2.94)	0.060 (0.34)	R-18.3 (3.23)	0.055 (0.31)	R-19.2 (3.39)	0.052 (0.30)
R-25.2 (4.44)	R-28.4 (5.00)	R-18.4 (3.25)	0.050 (0.31)	R-20.6 (3.63)	0.049 (0.28)	R-21.9 (3.85)	0.046 (0.26)

Temperature Indices

	R12.6	R16.8	R21	R25.1	
T_{i1}	0.71	0.73	0.73	0.74	Min T on sheathing, at clip and stud intersection
T_{i2}	0.85	0.89	0.90	0.90	Max T on sheathing, center of stud cavity between clips

Detail 5.1.48

Exterior and Interior Insulated 3 5/8" x 1 5/8" Steel Stud (16" o.c.) Wall Assembly with Nvelope – NV1 Clip System Supporting Cladding and R-12 Batt Insulation in Stud Cavity – Clear Wall

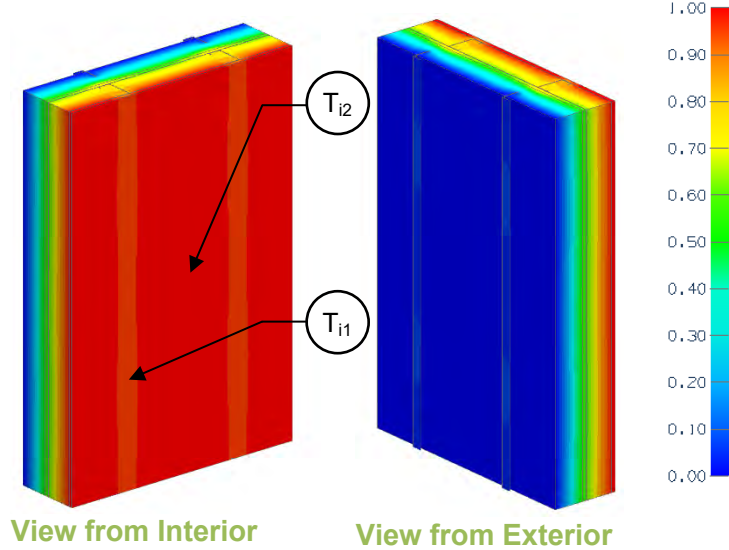

Thermal Performance Indicators

Assembly 1D (Nominal) R-Value	R_{1D}	R-14.3 (2.52 RSI) + exterior insulation
Transmittance / Resistance	U_o, R_o	"clear wall" U- and R-value
Surface Temperature Index ¹	T_i	0 = exterior temperature 1 = interior temperature

¹Assumptions and limitations for surface temperatures identified in ASHRAE 1365-RP

Nominal (1D) vs. Assembly Performance Indicators

Exterior Insulation 1D R-Value (RSI)	R_{1D} ft ² ·hr·°F / Btu (m ² K / W)	24" Vertical Spacing		36" Vertical Spacing		48" Vertical Spacing	
		R_o ft ² ·hr·°F / Btu (m ² K / W)	U_o Btu/ft ² ·hr·°F (W/m ² K)	R_o ft ² ·hr·°F / Btu (m ² K / W)	U_o Btu/ft ² ·hr·°F (W/m ² K)	R_o ft ² ·hr·°F / Btu (m ² K / W)	U_o Btu/ft ² ·hr·°F (W/m ² K)
R-8.4 (1.48)	R-22.7 (4.00)	R-15.9 (2.81)	0.063 (0.36)	R-16.4 (2.90)	0.061 (0.35)	R-16.9 (2.97)	0.059 (0.34)
R-12.6 (2.22)	R-26.9 (4.74)	R-18.3 (3.22)	0.055 (0.31)	R-19.2 (3.38)	0.052 (0.30)	R-19.8 (3.48)	0.051 (0.29)
R-16.8 (2.96)	R-31.1 (5.48)	R-20.6 (3.63)	0.049 (0.28)	R-22.0 (3.87)	0.046 (0.26)	R-22.9 (4.03)	0.044 (0.25)
R-21.0 (3.70)	R-35.3 (6.22)	R-22.5 (3.96)	0.044 (0.25)	R-24.4 (4.30)	0.041 (0.23)	R-25.4 (4.48)	0.039 (0.22)
R-25.2 (4.44)	R-39.5 (6.96)	R-24.2 (4.27)	0.041 (0.23)	R-26.7 (4.70)	0.037 (0.21)	R-28.1 (4.95)	0.036 (0.20)

Temperature Indices

	R8.4	R12.6	R16.8	R21	R25.1	
T_{i1}	0.42	0.47	0.50	0.52	0.53	Min T on sheathing, at clip and stud intersection
T_{i2}	0.65	0.70	0.74	0.77	0.79	Max T on sheathing, center of stud cavity between clips

Detail 5.1.49

Exterior and Interior Insulated 6" x 1 5/8" Steel Stud (16" o.c.) Wall Assembly with Nvelope – NV1 Clip System Supporting Cladding and R-19 Batt Insulation in Stud Cavity – Clear Wall



View from Interior

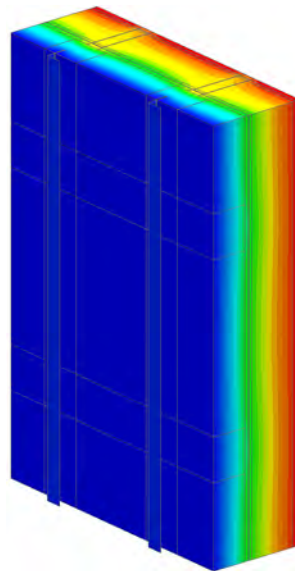

View from Exterior

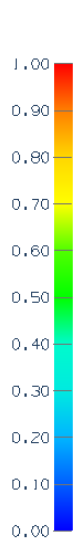

Thermal Performance Indicators

Assembly 1D (Nominal) R-Value	R_{1D}	R-21.3 (3.75 RSI) + exterior insulation
Transmittance / Resistance	U_o, R_o	"clear field" U- and R-values
Surface Temperature Index ¹	T_i	0 = exterior temperature 1 = interior temperature

¹Assumptions and limitations for surface temperatures identified in ASHRAE 1365-RP

Nominal (1D) vs. Assembly Performance Indicators

Exterior Insulation 1D R-value (RSI)	R_{1D} ft ² ·hr·°F / Btu (m ² K / W)	24" Vertical Spacing		36" Vertical Spacing		48" Vertical Spacing	
		R_o ft ² ·hr·°F / Btu (m ² K / W)	U_o Btu/ft ² ·hr·°F (W/m ² K)	R_o ft ² ·hr·°F / Btu (m ² K / W)	U_o Btu/ft ² ·hr·°F (W/m ² K)	R_o ft ² ·hr·°F / Btu (m ² K / W)	U_o Btu/ft ² ·hr·°F (W/m ² K)
R-6.3 (1.11)	R-27.6 (4.86)	R-16.8 (2.95)	0.060 (0.34)	R-17.2 (3.03)	0.058 (0.33)	R-17.3 (3.05)	0.058 (0.33)
R-8.4 (1.48)	R-29.7 (5.23)	R-18.2 (3.2)	0.055 (0.31)	R-18.8 (3.31)	0.053 (0.30)	R-19.1 (3.36)	0.052 (0.30)
R-12.6 (2.22)	R-33.9 (5.97)	R-20.5 (3.61)	0.049 (0.28)	R-21.5 (3.78)	0.047 (0.27)	R-21.9 (3.86)	0.046 (0.26)
R-16.8 (2.96)	R-38.1 (6.71)	R-22.8 (4.01)	0.044 (0.25)	R-24.2 (4.26)	0.041 (0.24)	R-25.0 (4.40)	0.040 (0.23)

Detail 5.1.50

Exterior and Interior Insulated 6" x 1 5/8" Slotted Steel R-Stud (16" o.c.) Wall Assembly with Nvelope – NV1 Clip System Supporting Cladding and R-19 Batt Insulation in Stud Cavity – Clear Wall

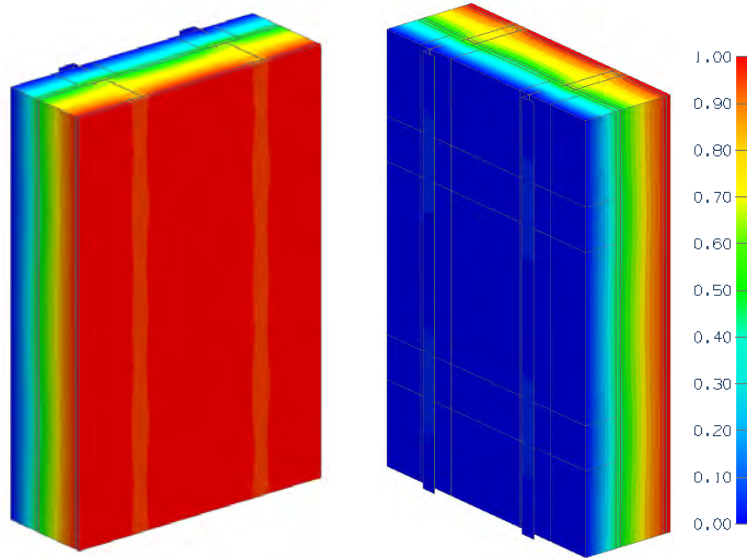

View from Interior

View from Exterior

Thermal Performance Indicators

Assembly 1D (Nominal) R-Value	R_{1D}	R-21.3 (3.75 RSI) + exterior insulation
Transmittance / Resistance	U_o, R_o	"clear field" U- and R-values
Surface Temperature Index ¹	T_i	0 = exterior temperature 1 = interior temperature

¹Assumptions and limitations for surface temperatures identified in ASHRAE 1365-RP

Nominal (1D) vs. Assembly Performance Indicators

Exterior Insulation 1D R-value (RSI)	R_{1D} ft ² ·hr·°F / Btu (m ² K / W)	24" Vertical Spacing		36" Vertical Spacing		48" Vertical Spacing	
		R_o ft ² ·hr·°F / Btu (m ² K / W)	U_o Btu/ft ² ·hr·°F (W/m ² K)	R_o ft ² ·hr·°F / Btu (m ² K / W)	U_o Btu/ft ² ·hr·°F (W/m ² K)	R_o ft ² ·hr·°F / Btu (m ² K / W)	U_o Btu/ft ² ·hr·°F (W/m ² K)
R-6.3 (1.11)	R-27.6 (4.86)	R-19.5 (3.44)	0.051 (0.29)	R-19.9 (3.51)	0.050 (0.29)	R-20.1 (3.54)	0.050 (0.28)
R-8.4 (1.48)	R-29.7 (5.23)	R-21.0 (3.69)	0.048 (0.27)	R-21.6 (3.81)	0.046 (0.26)	R-21.8 (3.85)	0.046 (0.26)
R-12.6 (2.22)	R-33.9 (5.97)	R-23.3 (4.11)	0.043 (0.24)	R-24.3 (4.29)	0.041 (0.23)	R-24.7 (4.35)	0.040 (0.23)
R-16.8 (2.96)	R-38.1 (6.71)	R-25.6 (4.52)	0.039 (0.22)	R-27.2 (4.78)	0.037 (0.21)	R-27.8 (4.90)	0.036 (0.20)

Detail 5.1.51

Exterior and Interior Insulated 3 5/8" x 1 5/8" Steel Stud (16" o.c.) Wall Assembly with Nvelope – Eko Thermobacket Clip System Supporting Cladding and R-13 Batt Insulation in Stud Cavity – Clear Wall



View from Interior

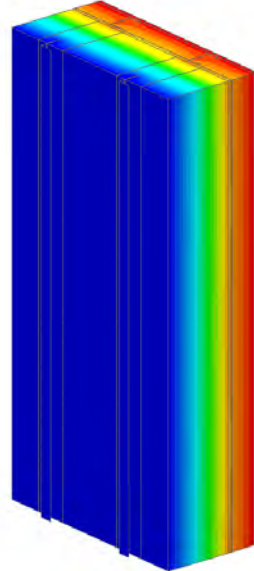

View from Exterior



Thermal Performance Indicators

Assembly 1D (Nominal) R-Value	R_{1D}	R-15.3 (2.69 RSI) + exterior insulation
Transmittance / Resistance	U_o, R_o	"clear field" U- and R-values
Surface Temperature Index ¹	T_i	0 = exterior temperature 1 = interior temperature

¹Assumptions and limitations for surface temperatures identified in ASHRAE 1365-RP

Nominal (1D) vs. Assembly Performance Indicators

Exterior Insulation 1D R-value (RSI)	R_{1D} ft ² ·hr·°F / Btu (m ² K / W)	R_o ft ² ·hr·°F / Btu (m ² K / W)	U_o Btu/ft ² ·hr ·°F (W/m ² K)
R-42 (7.40)	R-57.3 (10.09)	R-47.8 (8.37)	0.021 (0.119)

Detail 5.1.52

Exterior and Interior Insulated 3 5/8" x 1 5/8" Steel Stud (16" o.c.) Wall Assembly with Nvelope – Eko Thermobacket and NV1 Clip System Supporting Cladding and R-13 Batt Insulation in Stud Cavity – Clear Wall

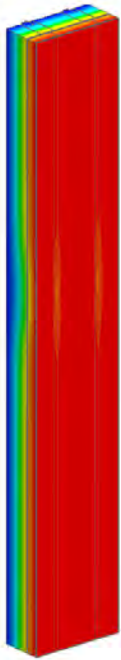

View from Interior

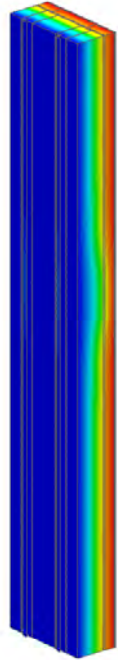

View from Exterior



Thermal Performance Indicators

Assembly 1D (Nominal) R-Value	R_{1D}	R-15.3 (2.69 RSI) + exterior insulation
Transmittance / Resistance	U_o, R_o	"clear field" U- and R-values
Surface Temperature Index ¹	T_i	0 = exterior temperature 1 = interior temperature

¹Assumptions and limitations for surface temperatures identified in ASHRAE 1365-RP

Nominal (1D) vs. Assembly Performance Indicators

Floor Height ft (mm)	Exterior Insulation 1D R-value (RSI)	R_{1D} ft ² ·hr·°F / Btu (m ² K / W)	R_o ft ² ·hr·°F / Btu (m ² K / W)	U_o Btu/ft ² ·hr ·°F (W/m ² K)
11' (3353)	R-42 (7.40)	R-57.3 (10.09)	R-35.6 (6.27)	0.028 (0.16)
13.5' (4115)	R-42 (7.40)	R-57.3 (10.09)	R-37.3 (6.57)	0.027 (0.15)
16' (4877)	R-42 (7.40)	R-57.3 (10.09)	R-38.6 (6.80)	0.026 (0.15)

Detail 5.1.53

Exterior Insulated 3 5/8" x 1 5/8" Steel Stud (16" O.C.) Wall Assembly with Cascadia Clip Fiberglass Thermal Spacers – Clear Wall

Thermal Performance Indicators

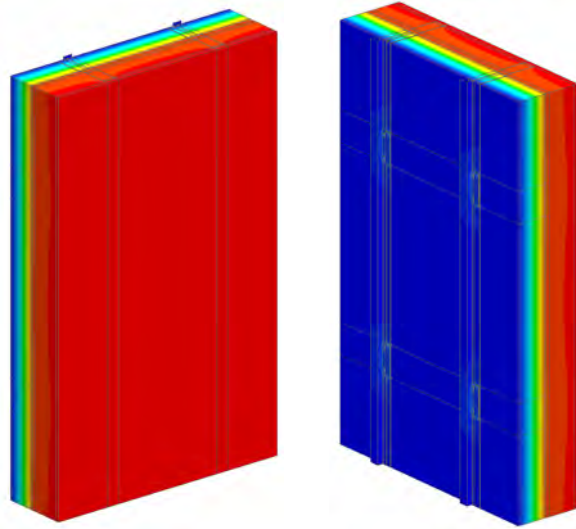

View from Interior

View from Exterior

Assembly 1D (Nominal) R-Value	R_{1D}	R-3.2 (0.56 RSI) + exterior insulation
Transmittance / Resistance	U_o, R_o	“clear wall” U- and R-value

Nominal (1D) vs. Assembly Performance Indicators

Exterior Insulation 1D R-Value (RSI)	R_{1D} ft ² ·hr·°F / Btu (m ² K / W)	26" Vertical Clip Spacing		36" Vertical Clip Spacing		48" Vertical Clip Spacing	
		R_o ft ² ·hr·°F / Btu (m ² K / W)	U_o Btu/ft ² ·hr·°F (W/m ² K)	R_o ft ² ·hr·°F / Btu (m ² K / W)	U_o Btu/ft ² ·hr·°F (W/m ² K)	R_o ft ² ·hr·°F / Btu (m ² K / W)	U_o Btu/ft ² ·hr·°F (W/m ² K)
R-8.4 (1.48)	R-11.6 (2.04)	R-11.1 (1.95)	0.090 (0.51)	R-11.4 (2.00)	0.088 (0.50)	R-11.6 (2.04)	0.086 (0.49)
R-10.5 (1.85)	R-13.7 (2.41)	R-12.9 (2.27)	0.078 (0.44)	R-13.3 (2.34)	0.075 (0.43)	R-13.5 (2.38)	0.074 (0.42)
R-12.6 (2.22)	R-15.8 (2.78)	R-14.6 (2.57)	0.069 (0.39)	R-15.0 (2.65)	0.066 (0.38)	R-15.3 (2.70)	0.065 (0.37)
R-14.7 (2.59)	R-17.9 (3.15)	R-16.4 (2.89)	0.061 (0.35)	R-16.9 (2.98)	0.059 (0.34)	R-17.3 (3.05)	0.058 (0.33)
R-16.8 (2.96)	R-20.0 (3.52)	R-18.2 (3.20)	0.055 (0.31)	R-18.8 (3.31)	0.053 (0.30)	R-19.2 (3.39)	0.052 (0.30)
R-21.0 (3.70)	R-24.2 (4.26)	R-21.5 (3.79)	0.046 (0.26)	R-22.4 (3.94)	0.045 (0.25)	R-22.9 (4.04)	0.044 (0.25)
R-25.2 (4.44)	R-28.4 (5.00)	R-24.8 (4.37)	0.040 (0.23)	R-25.9 (4.55)	0.039 (0.22)	R-26.6 (4.68)	0.038 (0.21)
R-33.6 (5.92)	R-36.8 (6.48)	R-31.4 (5.53)	0.032 (0.18)	R-32.9 (5.79)	0.030 (0.17)	R-33.9 (5.97)	0.030 (0.17)

Detail 5.1.54

Exterior and Interior Insulated 6" x 1 5/8" Steel Stud (16" o.c. and 24" o.c.) Wall Assembly with Vertical Clips (24" o.c. and 36" o.c.) Supporting Cladding and Owens Corning R-20 Batt Insulation in Stud Cavity – Clear Wall

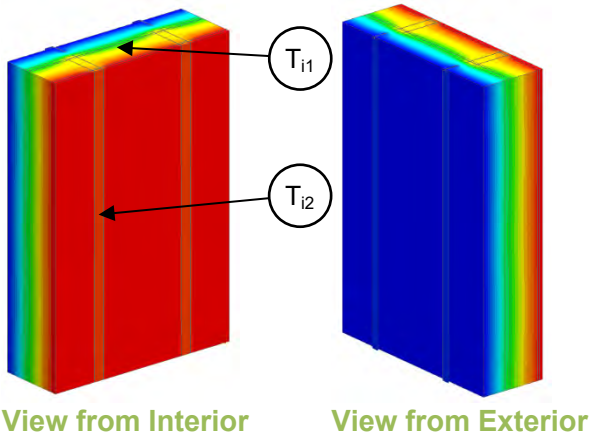

Thermal Performance Indicators

Assembly 1D (Nominal) R-Value	R_{1D}	R-22.4 (3.94) + insulation
Transmittance / Resistance without Anomaly	U_o, R_o	"clear field" U- and R-value, without connectors or joint
Surface Temperature Index ¹	T_i	0 = exterior temperature 1 = interior temperature

Nominal (1D) vs. Assembly Performance Indicators

16" o.c. Studs

Exterior Insulation 1D R-Value (RSI)	R_{1D} ft ² ·hr·°F / Btu (m ² K / W)	24" Vertical Clip Spacing		36" Vertical Clip Spacing	
		R_o ft ² ·hr·°F / Btu (m ² K / W)	U_o Btu/ft ² ·hr·°F (W/m ² K)	R_o ft ² ·hr·°F / Btu (m ² K / W)	U_o Btu/ft ² ·hr·°F (W/m ² K)
R-4.2 (0.74)	R-26.6 (4.68)	R-15.7 (2.77)	0.064 (0.36)	R-15.9 (2.80)	0.063 (0.36)
R-8.4 (1.48)	R-30.8 (5.42)	R-18.3 (3.22)	0.055 (0.31)	R-18.7 (3.30)	0.053 (0.30)
R-12.6 (2.22)	R-35.0 (6.16)	R-20.4 (3.59)	0.049 (0.28)	R-21.0 (3.69)	0.048 (0.27)
R-16.8 (2.96)	R-39.2 (6.90)	R-22.9 (4.03)	0.044 (0.25)	R-24.0 (4.23)	0.042 (0.24)

24" o.c. Studs

Exterior Insulation 1D R-Value (RSI)	R_{1D} ft ² ·hr·°F / Btu (m ² K / W)	24" Vertical Clip Spacing		36" Vertical Clip Spacing	
		R_o ft ² ·hr·°F / Btu (m ² K / W)	U_o Btu/ft ² ·hr·°F (W/m ² K)	R_o ft ² ·hr·°F / Btu (m ² K / W)	U_o Btu/ft ² ·hr·°F (W/m ² K)
R-4.2 (0.74)	R-26.6 (4.68)	R-18.2 (3.20)	0.055 (0.31)	R-18.3 (3.23)	0.055 (0.31)
R-8.4 (1.48)	R-30.8 (5.42)	R-21.1 (3.72)	0.047 (0.27)	R-21.5 (3.78)	0.047 (0.26)
R-12.6 (2.22)	R-35.0 (6.16)	R-23.6 (4.16)	0.042 (0.24)	R-24.3 (4.27)	0.041 (0.23)
R-16.8 (2.96)	R-39.2 (6.90)	R-26.5 (4.68)	0.038 (0.21)	R-27.6 (4.86)	0.036 (0.21)

Temperature Indices

	R4.2	R8.4	R12.6	R16.8	
T_{i1}	0.23	0.35	0.43	0.47	Min T on sheathing, between studs
T_{i2}	0.53	0.60	0.65	0.69	Max T on sheathing, at stud, between clips

Temperature indices taken from scenario with 16" o.c. studs with 24" vertical clip spacing. All other scenarios have higher minimum temperature index.

Detail 5.1.55

Exterior and Interior Insulated 6" x 1 5/8" Steel Stud (16" o.c. and 24" o.c.) Wall Assembly with Vertical Clips (24" O.C. and 36" o.c.) Supporting Cladding and Owens Corning R-22.5 Batt Insulation in Stud Cavity– Clear Wall

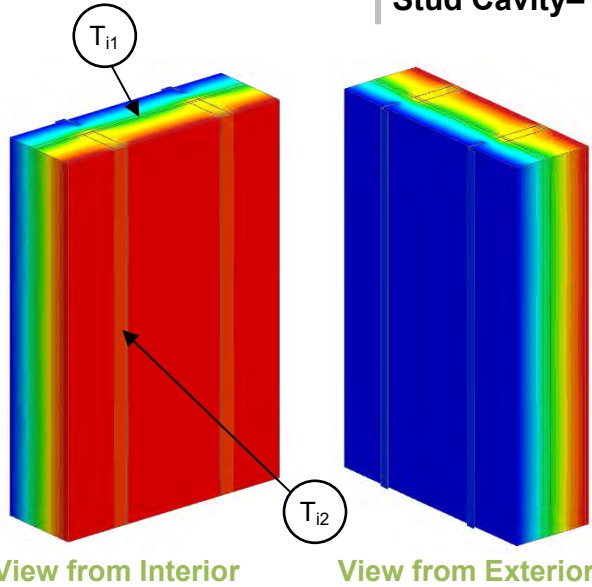

Thermal Performance Indicators

Assembly 1D (Nominal) R-Value	R_{1D}	R-24.9 (4.39 RSI) + exterior insulation
Transmittance / Resistance	U_o, R_o	"clear wall" U- and R-value
Surface Temperature Index ¹	T_i	0 = exterior temperature 1 = interior temperature

¹Assumptions and limitations for surface temperatures identified in ASHRAE 1365-RP

Nominal (1D) vs. Assembly Performance Indicators

16" o.c. Studs

Exterior Insulation 1D R-Value (RSI)	R_{1D} ft ² ·hr·°F / Btu (m ² K / W)	24" Vertical Clip Spacing		36" Vertical Clip Spacing	
		R_o ft ² ·hr·°F / Btu (m ² K / W)	U_o Btu/ft ² ·hr ·°F (W/m ² K)	R_o ft ² ·hr·°F / Btu (m ² K / W)	U_o Btu/ft ² ·hr ·°F (W/m ² K)
R-4.2 (0.74)	R-29.1 (5.13)	R-16.3 (2.86)	0.062 (0.35)	R-16.4 (2.9)	0.061 (0.35)
R-8.4 (1.48)	R-33.3 (5.86)	R-18.8 (3.32)	0.053 (0.30)	R-19.3 (3.39)	0.052 (0.29)
R-12.6 (2.22)	R-37.5 (6.60)	R-20.9 (3.68)	0.048 (0.27)	R-21.6 (3.81)	0.046 (0.26)
R-16.8 (2.96)	R-41.7 (7.34)	R-23.4 (4.12)	0.043 (0.24)	R-24.7 (4.34)	0.041 (0.23)

24" o.c. Studs

Exterior Insulation 1D R-Value (RSI)	R_{1D} ft ² ·hr·°F / Btu (m ² K / W)	24" Vertical Clip Spacing		36" Vertical Clip Spacing	
		R_o ft ² ·hr·°F / Btu (m ² K / W)	U_o Btu/ft ² ·hr ·°F (W/m ² K)	R_o ft ² ·hr·°F / Btu (m ² K / W)	U_o Btu/ft ² ·hr ·°F (W/m ² K)
R-4.2 (0.74)	R-29.1 (5.13)	R-18.9 (3.34)	0.053 (0.30)	R-19.1 (3.37)	0.052 (0.30)
R-8.4 (1.48)	R-33.3 (5.86)	R-21.9 (3.85)	0.046 (0.26)	R-22.3 (3.92)	0.045 (0.25)
R-12.6 (2.22)	R-37.5 (6.60)	R-24.4 (4.29)	0.041 (0.23)	R-25 (4.41)	0.040 (0.23)
R-16.8 (2.96)	R-41.7 (7.34)	R-27.3 (4.81)	0.037 (0.21)	R-28.4 (5.0)	0.035 (0.20)

Temperature Indices

	R4.2	R8.4	R12.6	R16.8	
T_{i1}	0.20	0.32	0.40	0.45	Min T on sheathing, between studs
T_{i2}	0.53	0.60	0.65	0.70	Max T on sheathing, at stud, between clips

Temperature indices taken from scenario with 24" o.c. studs with 36" vertical clip spacing. All other scenarios have higher minimum temperature index.

Detail 5.1.56

Exterior and Interior Insulated 6" x 1 5/8" Steel Stud (16" o.c. and 24" o.c.) Wall Assembly with Vertical Clips (24" O.C. and 36" o.c.) Supporting Cladding and Owens Corning R-24 Batt Insulation in Stud Cavity– Clear Wall

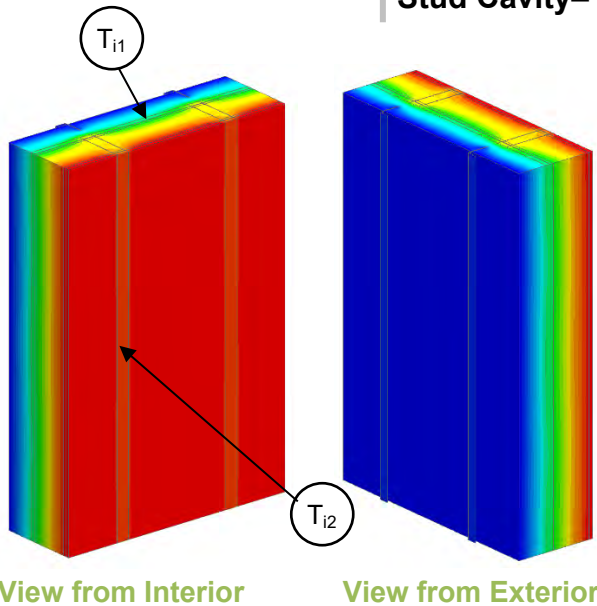

Thermal Performance Indicators

Assembly 1D (Nominal) R-Value	R_{1D}	R-26.4 (4.65 RSI) + exterior insulation
Transmittance / Resistance	U_o, R_o	"clear wall" U- and R-value
Surface Temperature Index ¹	T_i	0 = exterior temperature 1 = interior temperature

¹Assumptions and limitations for surface temperatures identified in ASHRAE 1365-RP

Nominal (1D) vs. Assembly Performance Indicators

16" o.c. Studs

Exterior Insulation 1D R-Value (RSI)	R_{1D} ft ² ·hr·°F / Btu (m ² K / W)	24" Vertical Clip Spacing		36" Vertical Clip Spacing	
		R_o ft ² ·hr·°F / Btu (m ² K / W)	U_o Btu/ft ² ·hr ·°F (W/m ² K)	R_o ft ² ·hr·°F / Btu (m ² K / W)	U_o Btu/ft ² ·hr ·°F (W/m ² K)
R-4.2 (0.74)	R-30.6 (5.39)	R-16.8 (2.95)	0.060 (0.34)	R-16.9 (2.98)	0.059 (0.34)
R-8.4 (1.48)	R-34.8 (6.13)	R-19.3 (3.40)	0.052 (0.29)	R-19.8 (3.48)	0.051 (0.29)
R-12.6 (2.22)	R-39.0 (6.87)	R-21.3 (3.76)	0.047 (0.27)	R-22.1 (3.89)	0.045 (0.26)
R-16.8 (2.96)	R-43.2 (7.61)	R-23.9 (4.21)	0.042 (0.24)	R-25.1 (4.43)	0.040 (0.23)

24" o.c. Studs

Exterior Insulation 1D R-Value (RSI)	R_{1D} ft ² ·hr·°F / Btu (m ² K / W)	24" Vertical Clip Spacing		36" Vertical Clip Spacing	
		R_o ft ² ·hr·°F / Btu (m ² K / W)	U_o Btu/ft ² ·hr ·°F (W/m ² K)	R_o ft ² ·hr·°F / Btu (m ² K / W)	U_o Btu/ft ² ·hr ·°F (W/m ² K)
R-4.2 (0.74)	R-30.6 (5.39)	R-19.7 (3.47)	0.051 (0.29)	R-19.8 (3.50)	0.050 (0.29)
R-8.4 (1.48)	R-34.8 (6.13)	R-22.6 (3.98)	0.044 (0.25)	R-23.0 (4.05)	0.043 (0.25)
R-12.6 (2.22)	R-39.0 (6.87)	R-25.1 (4.42)	0.040 (0.23)	R-25.7 (4.53)	0.039 (0.22)
R-16.8 (2.96)	R-43.2 (7.61)	R-28.0 (4.93)	0.036 (0.20)	R-29.1 (5.12)	0.034 (0.20)

Temperature Indices

	R4.2	R8.4	R12.6	R16.8	
T_{i1}	0.19	0.30	0.38	0.44	Min T on sheathing, between studs
T_{i2}	0.53	0.56	0.64	0.69	Max T on sheathing, at stud, between clips

Temperature indices taken from scenario with 24" o.c. studs with 36" vertical clip spacing. All other scenarios have higher minimum temperature index.

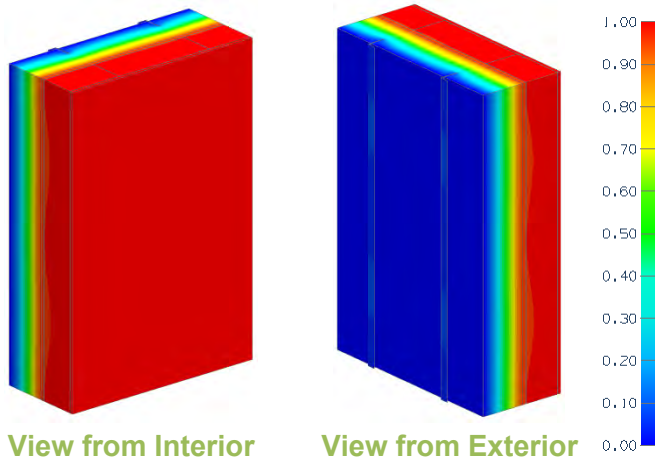
Detail 5.1.57**Exterior Insulated 6" x 1 5/8" Steel Stud (16" o.c. and 24" o.c.) Wall Assembly with Vertical Clips (24" o.c. and 36" o.c.) Supporting Cladding – Clear Wall****Thermal Performance Indicators**

Assembly 1D (Nominal) R-Value	R_{1D}	R-3.3 (0.58) + insulation
Transmittance / Resistance without Anomaly	U_o , R_o	"clear field" U- and R-value, without connectors or joint

Nominal (1D) vs. Assembly Performance Indicators**16" o.c. Studs**

Exterior Insulation 1D R-Value (RSI)	R_{1D} ft ² ·hr·°F / Btu (m ² K / W)	24" Vertical Clip Spacing		36" Vertical Clip Spacing	
		R_o ft ² ·hr·°F / Btu (m ² K / W)	U_o Btu/ft ² ·hr ·°F (W/m ² K)	R_o ft ² ·hr·°F / Btu (m ² K / W)	U_o Btu/ft ² ·hr ·°F (W/m ² K)
R-4.2 (0.74)	R-7.5 (1.32)	R-7.1 (1.24)	0.142 (0.81)	R-7.1 (1.26)	0.140 (0.80)
R-8.4 (1.48)	R-11.7 (2.06)	R-9.9 (1.75)	0.101 (0.57)	R-10.2 (1.80)	0.098 (0.56)
R-12.6 (2.22)	R-15.9 (2.80)	R-12.2 (2.15)	0.082 (0.47)	R-12.7 (2.23)	0.079 (0.45)
R-16.8 (2.96)	R-20.1 (3.54)	R-14.7 (2.59)	0.068 (0.39)	R-15.6 (2.75)	0.064 (0.36)
R-21.0 (3.70)	R-24.3 (4.28)	R-17.0 (3.00)	0.059 (0.33)	R-18.8 (3.30)	0.053 (0.30)
R-25.2 (4.44)	R-28.5 (5.02)	R-19.1 (3.37)	0.052 (0.30)	R-21.4 (3.77)	0.047 (0.26)
R-29.4 (5.18)	R-32.7 (5.76)	R-21.0 (3.71)	0.048 (0.27)	R-23.9 (4.22)	0.042 (0.24)

24" o.c. Studs

Exterior Insulation 1D R-Value (RSI)	R_{1D} ft ² ·hr·°F / Btu (m ² K / W)	24" Vertical Clip Spacing		36" Vertical Clip Spacing	
		R_o ft ² ·hr·°F / Btu (m ² K / W)	U_o Btu/ft ² ·hr ·°F (W/m ² K)	R_o ft ² ·hr·°F / Btu (m ² K / W)	U_o Btu/ft ² ·hr ·°F (W/m ² K)
R-4.2 (0.74)	R-7.5 (1.32)	R-7.2 (1.27)	0.139 (0.79)	R-7.3 (1.28)	0.137 (0.78)
R-8.4 (1.48)	R-11.7 (2.06)	R-10.5 (1.84)	0.096 (0.54)	R-10.7 (1.88)	0.094 (0.53)
R-12.6 (2.22)	R-15.9 (2.80)	R-13.2 (2.33)	0.076 (0.43)	R-13.6 (2.40)	0.073 (0.42)
R-16.8 (2.96)	R-20.1 (3.54)	R-16.1 (2.84)	0.062 (0.35)	R-16.9 (2.98)	0.059 (0.34)
R-21.0 (3.70)	R-24.3 (4.28)	R-18.9 (3.33)	0.053 (0.30)	R-20.3 (3.57)	0.049 (0.28)
R-25.2 (4.44)	R-28.5 (5.02)	R-21.5 (3.78)	0.047 (0.26)	R-23.4 (4.11)	0.043 (0.24)
R-29.4 (5.18)	R-32.7 (5.76)	R-23.9 (4.20)	0.042 (0.24)	R-26.3 (4.63)	0.038 (0.22)

Detail 5.1.58

Owens Corning Exterior Insulated 6" x 1 5/8" Steel Stud (16" o.c.) Wall Assembly with Thermally Isolated Vertical Brackets and Rail System (24" o.c.) Supporting Metal Cladding – Clear Wall

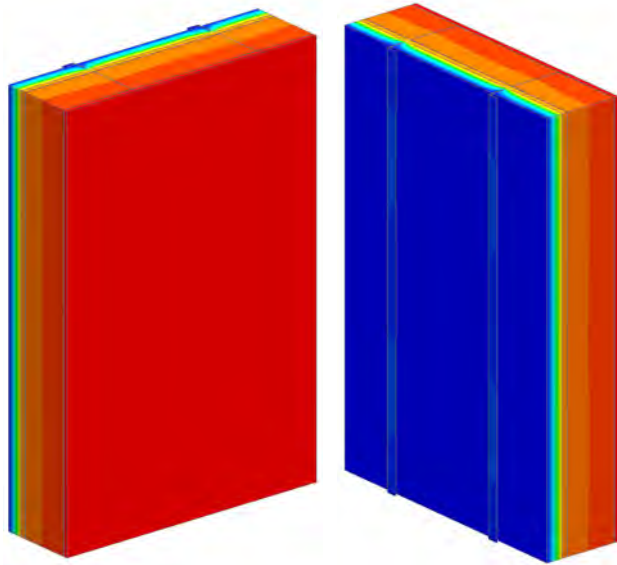

View from Interior

View from Exterior

Thermal Performance Indicators

Assembly 1D (Nominal) R-Value	R_{1D}	R-3.3 (0.58 RSI) + exterior insulation
Transmittance / Resistance without Anomaly	U_o , R_o	"clear wall" U- and R-value

¹Assumptions and limitations for surface temperatures identified in ASHRAE 1365-RP

Nominal (1D) vs. Assembly Performance Indicators

Exterior Insulation 1D R-Value (RSI)	R_{1D} ft ² ·hr·°F / Btu (m ² K / W)	R_o ft ² ·hr·°F / Btu (m ² K / W)	U_o Btu/ft ² ·hr ·°F (W/m ² K)
R-8.4 (1.48)	R-11.7 (2.06)	R-10.0 (1.77)	0.100 (0.57)
R-21.0 (3.70)	R-24.3 (4.28)	R-17.6 (3.10)	0.057 (0.32)

Detail 5.1.59

Exterior and Interior Insulated 6" x 1 5/8" Steel Stud (16" o.c. and 24" o.c.) Wall Assembly with Vertical Clips (24" o.c. and 36" o.c.) Supporting Cladding and R-20 Batt Insulation in Stud Cavity – Clear Wall

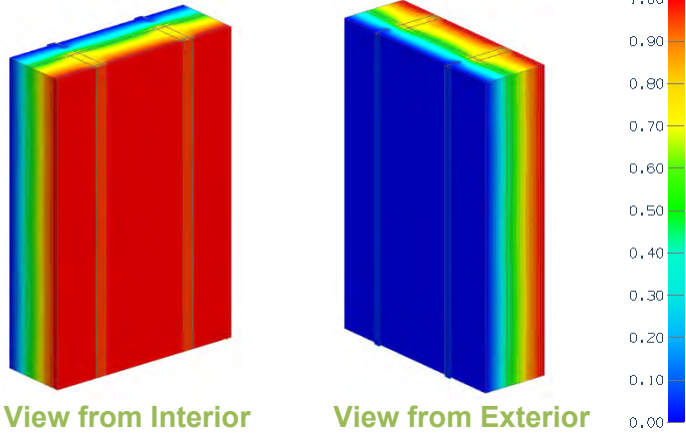

Thermal Performance Indicators

Assembly 1D (Nominal) R-Value	R_{1D}	R-22.4 (3.94) + insulation
Transmittance / Resistance without Anomaly	U_o, R_o	“clear field” U- and R-value, without connectors or joint

Nominal (1D) vs. Assembly Performance Indicators

16" o.c. Studs

Exterior Insulation 1D R-Value (RSI)	R_{1D} ft ² ·hr·°F / Btu (m ² K / W)	24" Vertical Clip Spacing		36" Vertical Clip Spacing	
		R_o ft ² ·hr·°F / Btu (m ² K / W)	U_o Btu/ft ² ·hr ·°F (W/m ² K)	R_o ft ² ·hr·°F / Btu (m ² K / W)	U_o Btu/ft ² ·hr ·°F (W/m ² K)
R-16.8 (2.96)	R-39.2 (6.90)	R-22.9 (4.03)	0.044 (0.25)	R-24.0 (4.23)	0.042 (0.24)
R-21.0 (3.70)	R-43.4 (7.64)	R-25.2 (4.44)	0.040 (0.23)	R-27.3 (4.80)	0.037 (0.21)
R-25.2 (4.44)	R-47.6 (8.38)	R-27.3 (4.81)	0.037 (0.21)	R-30.0 (5.28)	0.033 (0.19)
R-29.4 (5.18)	R-51.8 (9.12)	R-29.2 (5.15)	0.034 (0.19)	R-32.5 (5.72)	0.031 (0.17)

24" o.c. Studs

Exterior Insulation 1D R-Value (RSI)	R_{1D} ft ² ·hr·°F / Btu (m ² K / W)	24" Vertical Clip Spacing		36" Vertical Clip Spacing	
		R_o ft ² ·hr·°F / Btu (m ² K / W)	U_o Btu/ft ² ·hr ·°F (W/m ² K)	R_o ft ² ·hr·°F / Btu (m ² K / W)	U_o Btu/ft ² ·hr ·°F (W/m ² K)
R-16.8 (2.96)	R-39.2 (6.90)	R-26.6 (4.68)	0.038 (0.21)	R-27.6 (4.86)	0.036 (0.21)
R-21.0 (3.70)	R-43.4 (7.64)	R-29.3 (5.16)	0.034 (0.19)	R-31.0 (5.47)	0.032 (0.18)
R-25.2 (4.44)	R-47.6 (8.38)	R-31.8 (5.60)	0.031 (0.18)	R-34.1 (6.01)	0.029 (0.17)
R-29.4 (5.18)	R-51.8 (9.12)	R-34.2 (6.02)	0.029 (0.17)	R-37.0 (6.52)	0.027 (0.15)



Detail 5.1.60

Exterior and Interior Insulated 6" x 1 5/8" Steel Stud (16" o.c. and 24" o.c.) Wall Assembly with Steel Brick Anchors Supporting Brick Veneer and Owens Corning R-20 Batt Insulation in Stud Cavity – Clear Wall

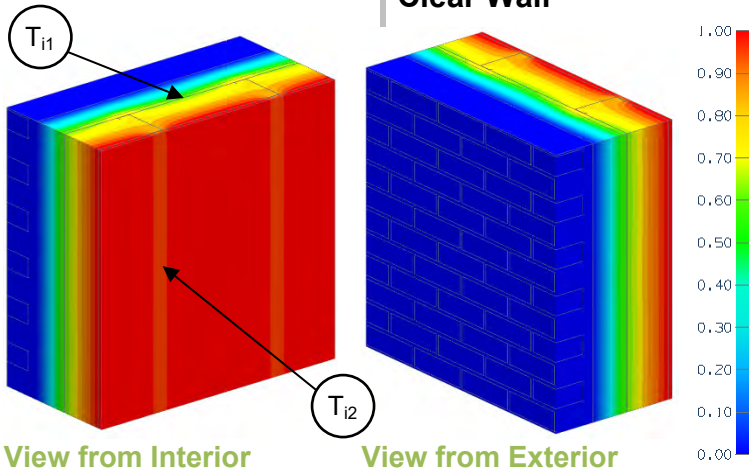

Thermal Performance Indicators

Assembly 1D (Nominal) R-Value	R_{1D}	R-23.4 (4.12 RSI) + exterior insulation
Transmittance / Resistance	U_o, R_o	"clear wall" U- and R-value
Surface Temperature Index ¹	T_i	0 = exterior temperature 1 = interior temperature

Nominal (1D) vs. Assembly Performance Indicators

Exterior Insulation 1D R-Value (RSI)	R_{1D} ft ² ·hr·°F / Btu (m ² K / W)	16" o.c.		24" o.c.	
		R_o ft ² ·hr·°F / Btu (m ² K / W)	U_o Btu/ft ² ·hr ·°F (W/m ² K)	R_o ft ² ·hr·°F / Btu (m ² K / W)	U_o Btu/ft ² ·hr ·°F (W/m ² K)
R-5.0 (0.88)	R-28.4 (5.01)	R-16.5 (2.91)	0.061 (0.34)	R-19.2 (3.38)	0.052 (0.30)
R-7.5 (1.32)	R-30.9 (5.45)	R-18.4 (3.23)	0.054 (0.31)	R-21.2 (3.74)	0.047 (0.27)
R-10.0 (1.76)	R-33.4 (5.89)	R-20.1 (3.54)	0.050 (0.28)	R-23.2 (4.09)	0.043 (0.25)
R-15.0 (2.64)	R-38.4 (6.77)	R-23.3 (4.10)	0.043 (0.24)	R-27.0 (4.75)	0.037 (0.21)

Temperature Indices

	R5	R7.5	R10	R15	
T_{i1}	0.29	0.36	0.42	0.51	Min T on sheathing, between studs
T_{i2}	0.56	0.61	0.64	0.69	Max T on sheathing, along studs

Temperature indices taken from scenario with 16" o.c. studs. All other scenarios have higher minimum temperature index.

Detail 5.1.61

Exterior and Interior Insulation 6" x 1 5/8" Steel Stud (16" o.c. and 24" o.c.) Wall Assembly with Brick Ties Supporting Brick Veneer and Owens Corning R-22.5 Batt Insulation in Stud Cavity – Clear Wall

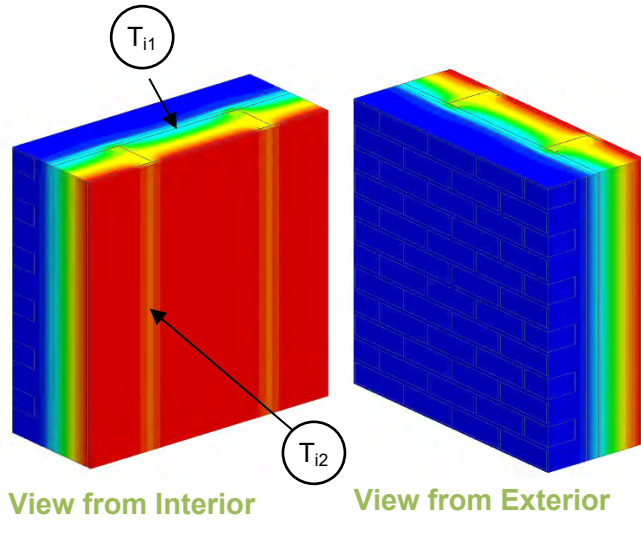

Thermal Performance Indicators

Assembly 1D (Nominal) R-Value	R_{1D}	R-24.4 (4.30 RSI) + exterior insulation
Transmittance / Resistance	U_o , R_o	"clear wall" U- and R-value
Surface Temperature Index ¹	T_i	0 = exterior temperature 1 = interior temperature

¹Assumptions and limitations for surface temperatures identified in ASHRAE 1365-RP

Nominal (1D) vs. Assembly Performance Indicators

Carbon Steel Anchor, Bolts, and Brick Ties

Exterior Insulation 1D R-Value (RSI)	R_{1D} ft ² ·hr·°F / Btu (m ² K / W)	16" o.c.		24" o.c.	
		R_o ft ² ·hr·°F / Btu (m ² K / W)	U_o Btu/ft ² ·hr·°F (W/m ² K)	R_o ft ² ·hr·°F / Btu (m ² K / W)	U_o Btu/ft ² ·hr·°F (W/m ² K)
R-5 (0.88)	R-29.4 (5.18)	R-17.5 (3.09)	0.057 (0.32)	R-20.3 (3.58)	0.049 (0.28)
R-7.5 (1.32)	R-31.9 (5.62)	R-19.9 (3.51)	0.050 (0.28)	R-22.8 (4.02)	0.044 (0.25)
R-10 (1.76)	R-34.4 (6.06)	R-22.3 (3.93)	0.045 (0.25)	R-25.2 (4.44)	0.040 (0.23)
R-15 (2.64)	R-39.4 (6.94)	R-26.8 (4.72)	0.037 (0.21)	R-30.0 (5.29)	0.033 (0.19)

Stainless Steel Anchor, Bolts, and Brick Ties

Exterior Insulation 1D R-Value (RSI)	R_{1D} ft ² ·hr·°F / Btu (m ² K / W)	16" o.c.		24" o.c.	
		R_o ft ² ·hr·°F / Btu (m ² K / W)	U_o Btu/ft ² ·hr·°F (W/m ² K)	R_o ft ² ·hr·°F / Btu (m ² K / W)	U_o Btu/ft ² ·hr·°F (W/m ² K)
R-5 (0.88)	R-29.4 (5.18)	R-17.6 (3.1)	0.057 (0.32)	R-20.3 (3.58)	0.049 (0.28)
R-7.5 (1.32)	R-31.9 (5.62)	R-20.0 (3.52)	0.050 (0.28)	R-22.8 (4.02)	0.044 (0.25)
R-10 (1.76)	R-34.4 (6.06)	R-22.4 (3.94)	0.045 (0.25)	R-25.3 (4.46)	0.040 (0.22)
R-15 (2.64)	R-39.4 (6.94)	R-27.0 (4.75)	0.037 (0.21)	R-30.1 (5.29)	0.033 (0.19)

Temperature Indices

	R5	R7.5	R10	R15	
T_{i1}	0.26	0.33	0.39	0.48	Min T on sheathing, between studs
T_{i2}	0.57	0.64	0.67	0.72	Max T on sheathing, along studs

Temperature indices taken from scenario with 24" o.c. studs. All other scenarios have higher minimum temperature index.

Detail 5.1.62

Exterior and Interior Insulated 6" x 1 5/8" Steel Stud (16" o.c. and 24" o.c.) Wall Assembly with Brick Ties Supporting Brick Veneer and Owens Corning R-24 Batt Insulation in Stud Cavity – Clear Wall

Thermal Performance Indicators

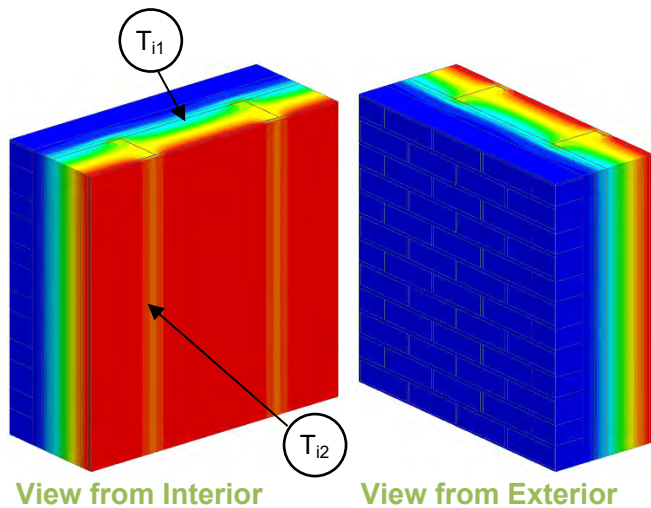

Assembly 1D (Nominal) R Value	R_{1D}	R-26.4 (4.65 RSI) + exterior insulation
Transmittance / Resistance	U_o, R_o	"clear wall" U- and R-value
Surface Temperature Index ¹	T_i	0 = exterior temperature 1 = interior temperature

¹Assumptions and limitations for surface temperatures identified in ASHRAE 1365-RP

Nominal (1D) vs. Assembly Performance Indicators

Carbon Steel Anchor, Bolts, and Brick Ties

Exterior Insulation 1D R-Value (RSI)	R_{1D} ft ² ·hr·°F / Btu (m ² K / W)	16" o.c.		24" o.c.	
		R_o ft ² ·hr·°F / Btu (m ² K / W)	U_o Btu/ft ² ·hr·°F (W/m ² K)	R_o ft ² ·hr·°F / Btu (m ² K / W)	U_o Btu/ft ² ·hr·°F (W/m ² K)
R-5 (0.88)	R-31.4 (5.53)	R-18.0 (3.17)	0.056 (0.32)	R-21.0 (3.70)	0.048 (0.27)
R-7.5 (1.32)	R-33.9 (5.97)	R-20.4 (3.59)	0.049 (0.28)	R-23.5 (4.15)	0.042 (0.24)
R-10 (1.76)	R-36.4 (6.41)	R-22.8 (4.01)	0.044 (0.25)	R-25.9 (4.57)	0.039 (0.22)
R-15 (2.64)	R-41.4 (7.29)	R-27.2 (4.78)	0.037 (0.21)	R-30.6 (5.40)	0.033 (0.19)

Stainless Steel Anchor, Bolts, and Brick Ties

Exterior Insulation 1D R-Value (RSI)	R_{1D} ft ² ·hr·°F / Btu (m ² K / W)	16" o.c.		24" o.c.	
		R_o ft ² ·hr·°F / Btu (m ² K / W)	U_o Btu/ft ² ·hr·°F (W/m ² K)	R_o ft ² ·hr·°F / Btu (m ² K / W)	U_o Btu/ft ² ·hr·°F (W/m ² K)
R-5 (0.88)	R-31.4 (5.53)	R-18.0 (3.17)	0.056 (0.32)	R-21.0 (3.70)	0.048 (0.27)
R-7.5 (1.32)	R-33.9 (5.97)	R-20.4 (3.6)	0.049 (0.28)	R-23.6 (4.15)	0.042 (0.24)
R-10 (1.76)	R-36.4 (6.41)	R-22.8 (4.02)	0.044 (0.25)	R-26.1 (4.59)	0.038 (0.22)
R-15 (2.64)	R-41.4 (7.29)	R-27.2 (4.78)	0.037 (0.21)	R-30.7 (5.41)	0.033 (0.18)

Temperature Indices

	R5	R7.5	R10	R15	
T_{i1}	0.25	0.32	0.37	0.47	Min T on sheathing, between studs
T_{i2}	0.57	0.63	0.67	0.72	Max T on sheathing, along studs

Temperature indices taken from scenario with 24" o.c. studs. All other scenarios have higher minimum temperature index.

Detail 5.1.63

Exterior and Interior Insulated 6" x 1 5/8" Steel Stud (16" o.c.) Wall Assembly with Heckmann Pos-I-Tie Veneer Anchoring System Supporting Brick Veneer and Owens Corning R-20 Batt Insulation in Stud Cavity – Clear Wall

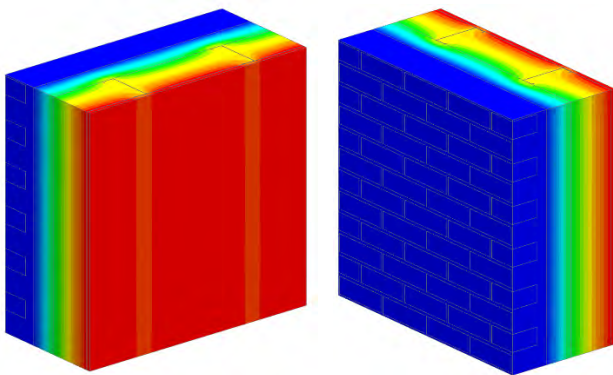

View from Interior

View from Exterior

Thermal Performance Indicators

Assembly 1D (Nominal) R-Value	R_{1D}	R-23.4 (4.12 RSI) + exterior insulation
Transmittance / Resistance without Anomaly	U_o , R_o	"clear wall" U- and R-value

¹Assumptions and limitations for surface temperatures identified in ASHRAE 1365-RP

Nominal (1D) vs. Assembly Performance Indicators

Exterior Insulation 1D R-Value (RSI)	R_{1D} ft ² ·hr·°F / Btu (m ² K / W)	R_o ft ² ·hr·°F / Btu (m ² K / W)	U_o Btu/ft ² ·hr ·°F (W/m ² K)
R-6.3 (1.11)	R-29.7 (5.23)	R-17.1 (3.02)	0.058 (0.33)
R-8.4 (1.48)	R-31.8 (5.60)	R-18.6 (3.28)	0.054 (0.31)
R-12.6 (2.22)	R-36.0 (6.34)	R-21.3 (3.75)	0.047 (0.27)
R-16.8 (2.96)	R-40.2 (7.08)	R-23.7 (4.17)	0.042 (0.24)
R-21.0 (3.70)	R-44.4 (7.82)	R-26.3 (4.62)	0.038 (0.22)

Detail 5.1.64

Exterior and Interior Insulated 6" x 1 5/8" Steel Stud (16" o.c.) Wall Assembly with Heckmann Pos-I-Tie Veneer Anchoring System Supporting Brick Veneer and Owens Corning R-22.5 Batt Insulation in Stud Cavity – Clear Wall

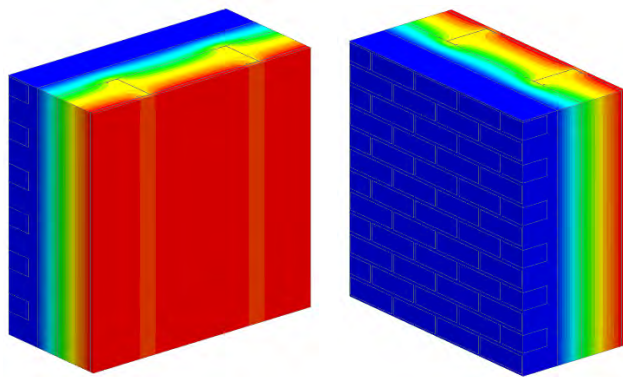

View from Interior

View from Exterior

Thermal Performance Indicators

Assembly 1D (Nominal) R-Value	R_{1D}	R-25.9 (4.56 RSI) + exterior insulation
Transmittance / Resistance without Anomaly	U_o , R_o	"clear wall" U- and R-value

¹Assumptions and limitations for surface temperatures identified in ASHRAE 1365-RP

Nominal (1D) vs. Assembly Performance Indicators

Exterior Insulation 1D R-Value (RSI)	R_{1D} ft ² ·hr·°F / Btu (m ² K / W)	R_o ft ² ·hr·°F / Btu (m ² K / W)	U_o Btu/ft ² ·hr·°F (W/m ² K)
R-6.3 (1.11)	R-32.2 (5.67)	R-17.7 (3.12)	0.056 (0.32)
R-8.4 (1.48)	R-34.3 (6.04)	R-19.2 (3.38)	0.052 (0.30)
R-12.6 (2.22)	R-38.5 (6.78)	R-21.9 (3.85)	0.046 (0.26)
R-16.8 (2.96)	R-42.7 (7.52)	R-24.2 (4.26)	0.041 (0.24)
R-21.0 (3.70)	R-46.9 (8.26)	R-26.8 (4.71)	0.037 (0.21)

Detail 5.1.65

Exterior and Interior Insulated 6" x 1 5/8" Steel Stud (16" o.c.) Wall Assembly with Heckmann Pos-I-Tie Veneer Anchoring System Supporting Brick Veneer and Owens Corning R-24 Batt Insulation in Stud Cavity – Clear Wall

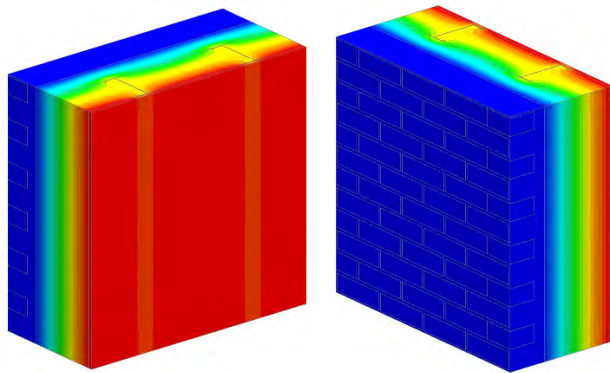

View from Interior

View from Exterior

Thermal Performance Indicators

Assembly 1D (Nominal) R-Value	R_{1D}	R-27.4 (4.83 RSI) + exterior insulation
Transmittance / Resistance without Anomaly	U_o, R_o	"clear wall" U- and R-value

¹Assumptions and limitations for surface temperatures identified in ASHRAE 1365-RP

Nominal (1D) vs. Assembly Performance Indicators

Exterior Insulation 1D R-Value (RSI)	R_{1D} ft ² ·hr·°F / Btu (m ² K / W)	R_o ft ² ·hr·°F / Btu (m ² K / W)	U_o Btu/ft ² ·hr ·°F (W/m ² K)
R-6.3 (1.11)	R-33.7 (5.94)	R-18.0 (3.17)	0.055 (0.32)
R-8.4 (1.48)	R-35.8 (6.31)	R-19.5 (3.43)	0.051 (0.29)
R-12.6 (2.22)	R-40.0 (7.04)	R-22.3 (3.93)	0.045 (0.25)
R-16.8 (2.96)	R-44.2 (7.78)	R-24.5 (4.31)	0.041 (0.23)
R-21.0 (3.70)	R-48.4 (8.52)	R-27.0 (4.76)	0.037 (0.21)

Detail 5.1.66

Exterior and Interior Insulated 6" x 1 5/8" Steel Stud (16" o.c.) Wall Assembly with Steel Anchor Supporting Brick Veneer, Owens Corning XPS Exterior Insulation and R-20 Batt Insulation in Stud Cavity – Clear Wall

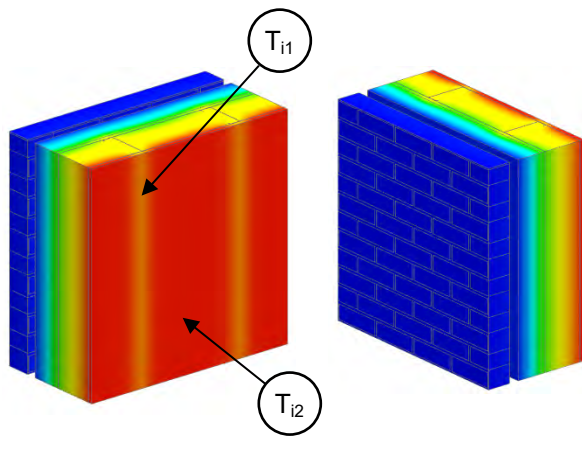

Thermal Performance Indicators

Assembly 1D (Nominal) R-Value	R_{1D}	R-23.0 (4.06 RSI) + exterior insulation
Transmittance / Resistance	U_o, R_o	"clear wall" U- and R-value
Surface Temperature Index	T_i	0 = exterior temperature 1 = interior temperature

View from Interior

View from Exterior

Nominal (1D) vs. Assembly Performance Indicators

Exterior Insulation 1D R-Value (RSI)	R_{1D} ft ² ·hr·°F / Btu (m ² K / W)	R_o ft ² ·hr·°F / Btu (m ² K / W)	U_o Btu/ft ² ·hr·°F (W/m ² K)
R-5.0 (0.88)	R-28.0 (4.94)	R-15.7 (2.77)	0.064 (0.361)
R-10.0 (1.76)	R-33.0 (5.82)	R-18.4 (3.24)	0.054 (0.309)
R-15.0 (2.64)	R-38.0 (6.70)	R-21.1 (3.71)	0.047 (0.270)
R-20.0 (3.52)	R-43.0 (7.58)	R-22.9 (4.04)	0.044 (0.247)
R-25.0 (4.40)	R-48.0 (8.46)	R-24.9 (4.39)	0.040 (0.228)

Temperature Indices

	R5	R15	R20	R25	
T_{i1}	0.30	0.44	0.44	0.47	Min T on sheathing, at anchor
T_{i2}	0.28	0.49	0.54	0.59	Min T on sheathing, between studs and anchors

Temperature indices listed for selected scenarios. All other scenarios to be interpolated.

Detail 5.1.67

Exterior Insulated 3 5/8" x 1 5/8" Steel Stud (16" o.c.) Wall Assembly with Hohmann & Barnard Masonry Zinc 2-Seal Anchor Supporting Brick Veneer – Clear Wall

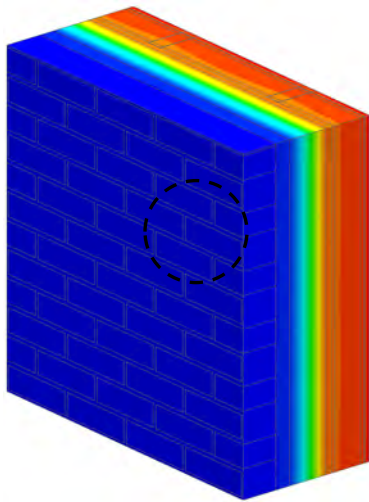

View of Exterior

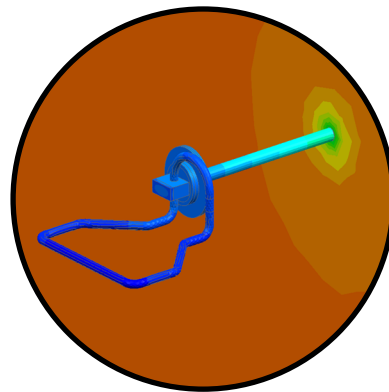

View of Anchoring Tie

Thermal Performance Indicators

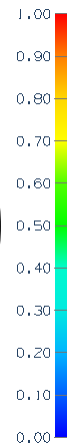

Assembly 1D (Nominal) R-Value	R_{1D}	R-4.3 (0.76 RSI) + exterior insulation
Transmittance / Resistance	U_o, R_o	"Clear wall" U- and R-value: a = without batt insulation
Surface Temperature Index ¹	T_i	0 = exterior temperature 1 = interior temperature

¹Assumptions and limitations for surface temperatures identified in ASHRAE 1365-RP

Nominal (1D) vs. Assembly Performance Indicators

Exterior Insulation 1D R-Value (RSI)	R_{1D} ft ² ·hr·°F / Btu (m ² K / W)	8" Vertical Clip Spacing		16" Vertical Clip Spacing		24" Vertical Clip Spacing	
		R_o ft ² ·hr·°F / Btu (m ² K / W)	U_o Btu/ft ² ·hr·°F (W/m ² K)	R_o ft ² ·hr·°F / Btu (m ² K / W)	U_o Btu/ft ² ·hr·°F (W/m ² K)	R_o ft ² ·hr·°F / Btu (m ² K / W)	U_o Btu/ft ² ·hr·°F (W/m ² K)
R-4.2 (0.74)	R-8.5 (1.50)	R-7.3 (1.29)	0.137 (0.777)	R-7.7 (1.35)	0.130 (0.740)	R-7.8 (1.38)	0.128 (0.725)
R-8.4 (1.48)	R-12.7 (2.24)	R-10.1 (1.78)	0.099 (0.563)	R-11.1 (1.95)	0.090 (0.514)	R-11.5 (2.02)	0.087 (0.495)
R-12.6 (2.22)	R-16.9 (2.96)	R-12.5 (2.20)	0.080 (0.454)	R-14.2 (2.50)	0.071 (0.401)	R-14.9 (2.62)	0.067 (0.381)
R-16.8 (2.96)	R-21.1 (3.72)	R-14.7 (2.59)	0.068 (0.386)	R-17.1 (3.01)	0.058 (0.332)	R-18.2 (3.20)	0.055 (0.313)

Temperature Indices

	R4.2	R8.4	R12.6	R16.8	
T_{i1}	0.42	0.47	0.51	0.55	Min T on sheathing behind stud at Tie Penetration
T_{i2}	0.72	0.79	0.83	0.86	Max T on sheathing at edge of Steel Stud Flange aligned with Tie Penetration

Detail 5.1.68

Exterior Insulated 3 5/8" x 1 5/8" Steel Stud (16" o.c.) Wall Assembly with Hohmann & Barnard Masonry Stainless Steel 2-Seal Thermal Anchor Supporting Brick Veneer – Clear Wall

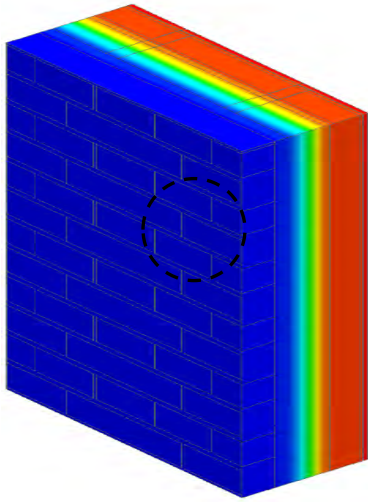

View of Exterior

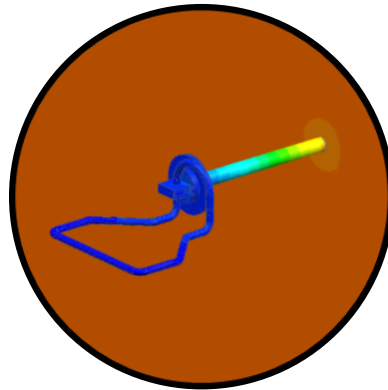

View of Anchoring Tie

Thermal Performance Indicators



Assembly 1D (Nominal) R-Value	R_{1D}	R-4.4 (0.76 RSI) + exterior insulation
Transmittance / Resistance	U_o , R_o	"Clear wall" U - and R -value
Surface Temperature Index ¹	T_i	0 = exterior temperature 1 = interior temperature

¹Assumptions and limitations for surface temperatures identified in ASHRAE 1365-RP

Nominal (1D) vs. Assembly Performance Indicators

Exterior Insulation 1D R-Value (RSI)	R_{1D} ft ² ·hr·°F / Btu (m ² K / W)	8" Vertical Clip Spacing		16" Vertical Clip Spacing		24" Vertical Clip Spacing	
		R_o ft ² ·hr·°F / Btu (m ² K / W)	U_o Btu/ft ² ·hr ·°F (W/m ² K)	R_o ft ² ·hr·°F / Btu (m ² K / W)	U_o Btu/ft ² ·hr ·°F (W/m ² K)	R_o ft ² ·hr·°F / Btu (m ² K / W)	U_o Btu/ft ² ·hr ·°F (W/m ² K)
R-4.2 (0.74)	R-8.5 (1.50)	R-7.8 (1.37)	0.129 (0.731)	R-8.0 (1.4)	0.126 (0.714)	R-8.0 (1.41)	0.125 (0.708)
R-8.4 (1.48)	R-12.7 (2.24)	R-11.5 (2.02)	0.087 (0.495)	R-11.9 (2.1)	0.084 (0.477)	R-12.0 (2.12)	0.083 (0.471)
R-12.6 (2.22)	R-16.9 (2.96)	R-15.2 (2.67)	0.066 (0.375)	R-15.8 (2.78)	0.063 (0.359)	R-16.1 (2.83)	0.062 (0.354)
R-16.8 (2.96)	R-21.1 (3.72)	R-18.8 (3.31)	0.053 (0.302)	R-19.7 (3.47)	0.051 (0.288)	R-20.1 (3.53)	0.050 (0.283)

Temperature Indices

	R4.2	R8.4	R12.6	R16.8	
T_{i1}	0.67	0.75	0.81	0.80	Min T on sheathing behind stud at Tie Penetration
T_{i2}	0.74	0.82	0.86	0.89	Max T on sheathing at edge of Steel Stud Flange aligned with Tie Penetration

Detail 5.1.69

Exterior Insulated 3 5/8" x 1 5/8" Steel Stud (16" o.c.) Wall Assembly with Hohmann & Barnard Masonry Stainless Steel 2-Seal Thermal Wing Nut Anchor Supporting Brick Veneer – Clear Wall

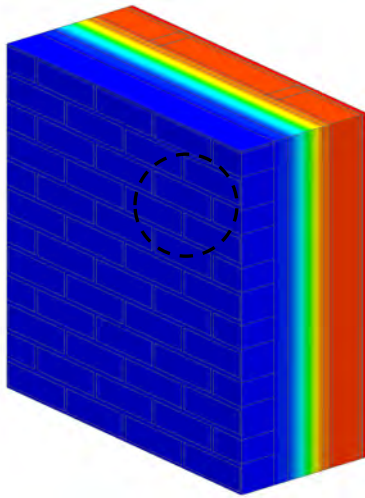

View of Exterior

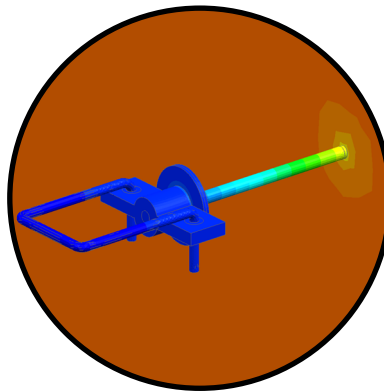

View of Anchoring Tie

Thermal Performance Indicators

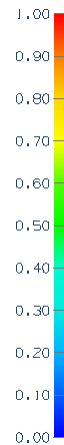

Assembly 1D (Nominal) R-Value	R_{1D}	R-4.3 (0.76 RSI) + exterior insulation
Transmittance / Resistance	U_o , R_o	"Clear wall" U - and R -value
Surface Temperature Index ¹	T_i	0 = exterior temperature 1 = interior temperature

¹Assumptions and limitations for surface temperatures identified in ASHRAE 1365-RP

Nominal (1D) vs. Assembly Performance Indicators

Exterior Insulation 1D R-Value (RSI)	R_{1D} ft ² ·hr·°F / Btu (m ² K / W)	8" Vertical Clip Spacing		16" Vertical Clip Spacing		24" Vertical Clip Spacing	
		R_o ft ² ·hr·°F / Btu (m ² K / W)	U_o Btu/ft ² ·hr ·°F (W/m ² K)	R_o ft ² ·hr·°F / Btu (m ² K / W)	U_o Btu/ft ² ·hr ·°F (W/m ² K)	R_o ft ² ·hr·°F / Btu (m ² K / W)	U_o Btu/ft ² ·hr ·°F (W/m ² K)
R-4.2 (0.74)	R-8.5 (1.50)	R-7.7 (1.36)	0.130 (0.737)	R-7.9 (1.39)	0.127 (0.721)	R-7.9 (1.40)	0.126 (0.716)
R-8.4 (1.48)	R-12.7 (2.24)	R-11.4 (2.01)	0.088 (0.498)	R-11.8 (2.08)	0.085 (0.481)	R-11.9 (2.10)	0.084 (0.475)
R-12.6 (2.22)	R-16.9 (2.96)	R-15.0 (2.64)	0.067 (0.379)	R-15.7 (2.76)	0.064 (0.362)	R-16.0 (2.81)	0.063 (0.356)
R-16.8 (2.96)	R-21.1 (3.72)	R-18.6 (3.27)	0.054 (0.306)	R-19.6 (3.44)	0.051 (0.290)	R-19.9 (3.51)	0.050 (0.285)

Temperature Indices

	R4.2	R8.4	R12.6	R16.8	
T_{i1}	0.56	0.66	0.72	0.76	Min T on sheathing behind stud at Tie Penetration
T_{i2}	0.75	0.83	0.87	0.90	Max T on sheathing at edge of Steel Stud Flange aligned with Tie Penetration

Detail 5.1.70

Exterior Insulated 3 5/8" x 1 5/8" Steel Stud (16" o.c.) Wall Assembly with Hohmann & Barnard Masonry Carbon Steel X-Seal Anchor Supporting Brick Veneer – Clear Wall

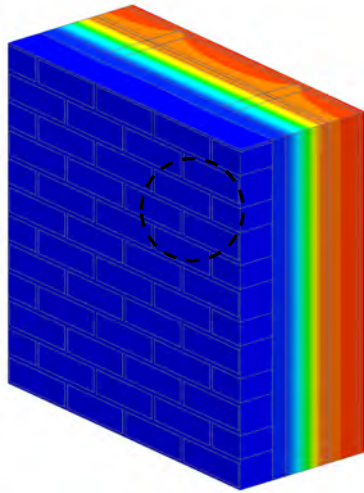

View of Exterior

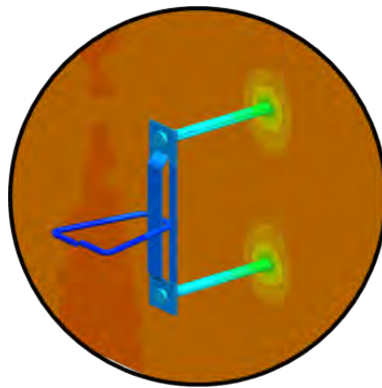

View of Anchoring Tie

Thermal Performance Indicators



Assembly 1D (Nominal) R-Value	R_{1D}	R-4.3 (0.76 RSI) + exterior insulation
Transmittance / Resistance	U_o , R_o	"Clear wall" U_o and R-value
Surface Temperature Index ¹	T_i	0 = exterior temperature 1 = interior temperature

¹Assumptions and limitations for surface temperatures identified in ASHRAE 1365-RP

Nominal (1D) vs. Assembly Performance Indicators

Exterior Insulation 1D R-Value (RSI)	R_{1D} ft ² ·hr·°F / Btu (m ² K / W)	8" Vertical Clip Spacing		16" Vertical Clip Spacing		24" Vertical Clip Spacing	
		R_o ft ² ·hr·°F / Btu (m ² K / W)	U_o Btu/ft ² ·hr ·°F (W/m ² K)	R_o ft ² ·hr·°F / Btu (m ² K / W)	U_o Btu/ft ² ·hr ·°F (W/m ² K)	R_o ft ² ·hr·°F / Btu (m ² K / W)	U_o Btu/ft ² ·hr ·°F (W/m ² K)
R-4.2 (0.74)	R-8.5 (1.50)	R-6.7 (1.19)	0.149 (0.844)	R-7.3 (1.29)	0.137 (0.776)	R-7.6 (1.33)	0.132 (0.750)
R-8.4 (1.48)	R-12.7 (2.24)	R-8.7 (1.54)	0.115 (0.651)	R-10.1 (1.78)	0.099 (0.563)	R-10.7 (1.89)	0.093 (0.530)
R-12.6 (2.22)	R-16.9 (2.96)	R-10.3 (1.82)	0.097 (0.551)	R-12.5 (2.20)	0.080 (0.456)	R-13.5 (2.39)	0.074 (0.419)
R-16.8 (2.96)	R-21.1 (3.72)	R-11.7 (2.06)	0.086 (0.486)	R-14.6 (2.57)	0.068 (0.389)	R-16.2 (2.85)	0.062 (0.351)

Temperature Indices

	R4.2	R8.4	R12.6	R16.8	
T_{i1}	0.47	0.53	0.57	0.60	Min T on sheathing behind stud at Tie Penetration
T_{i2}	0.69	0.76	0.80	0.82	Max T on sheathing at edge of Steel Stud Flange aligned with Tie Penetration

Detail 5.1.71

Exterior Insulated 3 5/8" x 1 5/8" Steel Stud (16" o.c.) Wall Assembly with Hohmann & Barnard Masonry Stainless Steel X-Seal Anchor Supporting Brick Veneer – Clear Wall

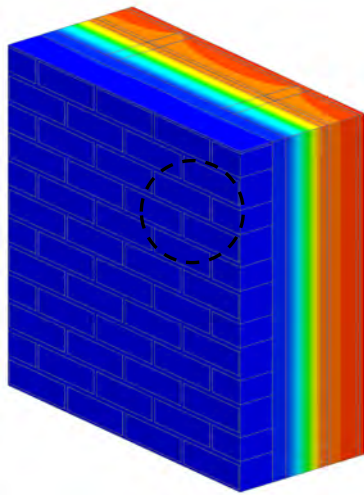

View of Exterior

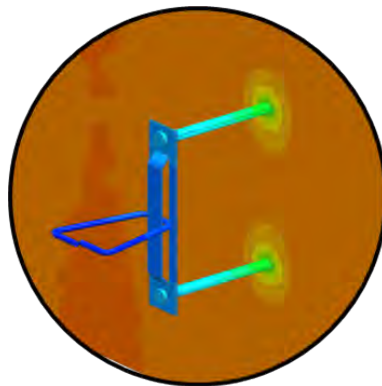

View of Anchoring Tie

Thermal Performance Indicators



Assembly 1D (Nominal) R-Value	R_{1D}	R-4.3 (0.76 RSI) + exterior insulation
Transmittance / Resistance	U_o , R_o	"Clear wall" U - and R -value
Surface Temperature Index ¹	T_i	0 = exterior temperature 1 = interior temperature

¹Assumptions and limitations for surface temperatures identified in ASHRAE 1365-RP

Nominal (1D) vs. Assembly Performance Indicators

Exterior Insulation 1D R-Value (RSI)	R_{1D} ft ² ·hr·°F / Btu (m ² K / W)	8" Vertical Clip Spacing		16" Vertical Clip Spacing		24" Vertical Clip Spacing	
		R_o ft ² ·hr·°F / Btu (m ² K / W)	U_o Btu/ft ² ·hr ·°F (W/m ² K)	R_o ft ² ·hr·°F / Btu (m ² K / W)	U_o Btu/ft ² ·hr ·°F (W/m ² K)	R_o ft ² ·hr·°F / Btu (m ² K / W)	U_o Btu/ft ² ·hr ·°F (W/m ² K)
R-4.2 (0.74)	R-8.5 (1.50)	R-7.1 (1.24)	0.142 (0.804)	R-7.5 (1.33)	0.133 (0.754)	R-7.7 (1.36)	0.129 (0.735)
R-8.4 (1.48)	R-12.7 (2.24)	R-9.6 (1.69)	0.104 (0.593)	R-10.7 (1.88)	0.093 (0.531)	R-11.2 (1.97)	0.089 (0.507)
R-12.6 (2.22)	R-16.9 (2.96)	R-11.7 (2.06)	0.086 (0.486)	R-13.6 (2.4)	0.073 (0.417)	R-14.4 (2.54)	0.069 (0.394)
R-16.8 (2.96)	R-21.1 (3.72)	R-13.5 (2.39)	0.074 (0.419)	R-16.2 (2.85)	0.062 (0.351)	R-17.5 (3.09)	0.057 (0.324)

Temperature Indices

	R4.2	R8.4	R12.6	R16.8	
T_{i1}	0.56	0.63	0.67	0.70	Min T on sheathing behind stud at Tie Penetration
T_{i2}	0.71	0.78	0.82	0.85	Max T on sheathing at edge of Steel Stud Flange aligned with Tie Penetration

Detail 5.1.72

Exterior Insulated 3 5/8" x 1 5/8" Steel Stud (16" o.c.) Wall Assembly with Hohmann & Barnard Masonry Carbon Steel HB-213 2X Anchor Supporting Brick Veneer – Clear Wall

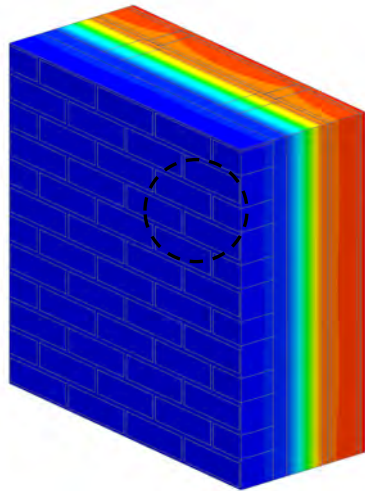

View of Exterior

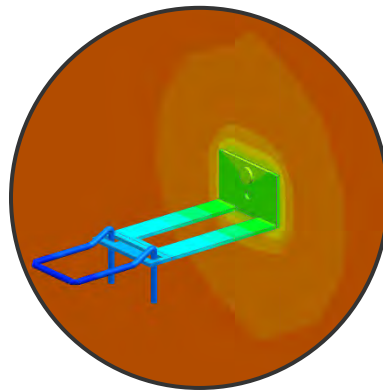

View of Anchoring Tie

Thermal Performance Indicators



Assembly 1D (Nominal) R-Value	R_{1D}	R-4.3 (0.76 RSI) + exterior insulation
Transmittance / Resistance	U_o , R_o	"Clear wall" U - and R -value
Surface Temperature Index ¹	T_i	0 = exterior temperature 1 = interior temperature

¹Assumptions and limitations for surface temperatures identified in ASHRAE 1365-RP

Nominal (1D) vs. Assembly Performance Indicators

Exterior Insulation 1D R-Value (RSI)	R_{1D} ft ² ·hr·°F / Btu (m ² K / W)	8" Vertical Clip Spacing		16" Vertical Clip Spacing		24" Vertical Clip Spacing	
		R_o ft ² ·hr·°F / Btu (m ² K / W)	U_o Btu/ft ² ·hr ·°F (W/m ² K)	R_o ft ² ·hr·°F / Btu (m ² K / W)	U_o Btu/ft ² ·hr ·°F (W/m ² K)	R_o ft ² ·hr·°F / Btu (m ² K / W)	U_o Btu/ft ² ·hr ·°F (W/m ² K)
R-4.2 (0.74)	R-8.5 (1.50)	R-7.4 (1.30)	0.136 (0.770)	R-7.9 (1.39)	0.127 (0.722)	R-8.0 (1.42)	0.124 (0.706)
R-8.4 (1.48)	R-12.7 (2.24)	R-9.8 (1.72)	0.102 (0.580)	R-11.0 (1.94)	0.091 (0.516)	R-11.4 (2.01)	0.088 (0.498)
R-12.6 (2.22)	R-16.9 (2.96)	R-11.8 (2.08)	0.085 (0.480)	R-13.6 (2.39)	0.074 (0.418)	R-14.7 (2.58)	0.068 (0.387)
R-16.8 (2.96)	R-21.1 (3.72)	R-13.7 (2.40)	0.073 (0.416)	R-16.4 (2.89)	0.061 (0.346)	R-18.0 (3.17)	0.056 (0.315)

Temperature Indices

	R4.2	R8.4	R12.6	R16.8	
T_{i1}	0.59	0.64	0.69	0.71	Min T on sheathing behind stud at Tie Penetration
T_{i2}	0.72	0.78	0.82	0.84	Max T on sheathing at edge of Steel Stud Flange aligned with Tie Penetration

Detail 5.1.73

Exterior Insulated 3 5/8" x 1 5/8" Steel Stud (16" o.c.) Wall Assembly with Hohmann & Barnard Masonry Stainless Steel HB-213 2X Anchor Supporting Brick Veneer – Clear Wall

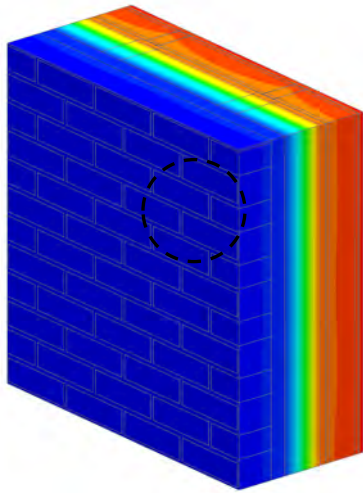

View of Exterior

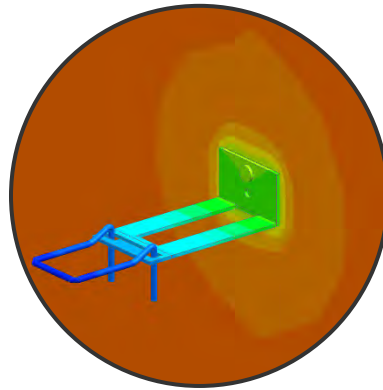

View of Anchoring Tie

Thermal Performance Indicators



Assembly 1D (Nominal) R-Value	R_{1D}	R-4.3 (0.76 RSI) + exterior insulation
Transmittance / Resistance	U_o , R_o	"Clear wall" U - and R -value
Surface Temperature Index ¹	T_i	0 = exterior temperature 1 = interior temperature

¹Assumptions and limitations for surface temperatures identified in ASHRAE 1365-RP

Nominal (1D) vs. Assembly Performance Indicators

Exterior Insulation 1D R-Value (RSI)	R_{1D} ft ² ·hr·°F / Btu (m ² K / W)	8" Vertical Clip Spacing		16" Vertical Clip Spacing		24" Vertical Clip Spacing	
		R_o ft ² ·hr·°F / Btu (m ² K / W)	U_o Btu/ft ² ·hr ·°F (W/m ² K)	R_o ft ² ·hr·°F / Btu (m ² K / W)	U_o Btu/ft ² ·hr ·°F (W/m ² K)	R_o ft ² ·hr·°F / Btu (m ² K / W)	U_o Btu/ft ² ·hr ·°F (W/m ² K)
R-4.2 (0.74)	R-8.5 (1.50)	R-7.7 (1.35)	0.130 (0.740)	R-8.1 (1.43)	0.123 (0.701)	R-8.2 (1.45)	0.122 (0.691)
R-8.4 (1.48)	R-12.7 (2.24)	R-10.9 (1.92)	0.092 (0.520)	R-11.6 (2.04)	0.086 (0.490)	R-11.9 (2.1)	0.084 (0.476)
R-12.6 (2.22)	R-16.9 (2.96)	R-13.6 (2.39)	0.074 (0.418)	R-14.9 (2.62)	0.067 (0.382)	R-15.5 (2.74)	0.064 (0.365)
R-16.8 (2.96)	R-21.1 (3.72)	R-16 (2.81)	0.063 (0.356)	R-18.1 (3.19)	0.055 (0.313)	R-19.0 (3.35)	0.053 (0.298)

Temperature Indices

	R4.2	R8.4	R12.6	R16.8	
T_{i1}	0.66	0.73	0.78	0.81	Min T on sheathing behind stud at Tie Penetration
T_{i2}	0.73	0.80	0.84	0.87	Max T on sheathing at edge of Steel Stud Flange aligned with Tie Penetration

Detail 5.1.74

Exterior Insulated 3 5/8" x 1 5/8" Steel Stud (16" o.c.) Wall Assembly with Hohmann & Barnard Masonry Carbon Steel HB-200-X Steel Tie Supporting Brick Veneer – Clear Wall

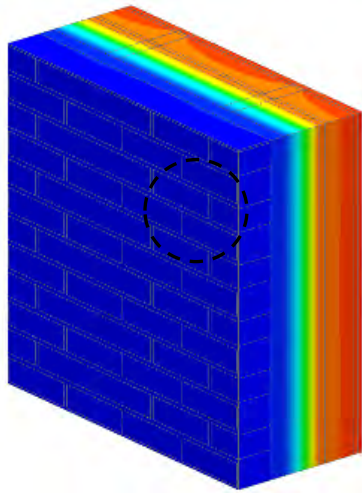

View of Exterior

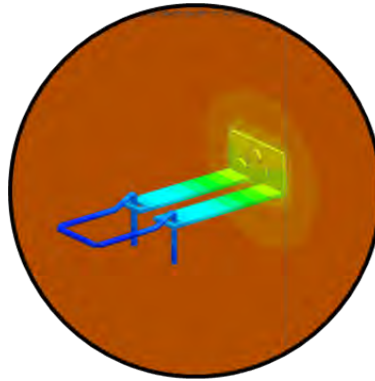

View of Anchoring Tie

Thermal Performance Indicators



Assembly 1D (Nominal) R-Value	R_{1D}	R-4.3 (0.76 RSI) + exterior insulation
Transmittance / Resistance	U_o , R_o	"Clear wall" U - and R -value
Surface Temperature Index ¹	T_i	0 = exterior temperature 1 = interior temperature

¹Assumptions and limitations for surface temperatures identified in ASHRAE 1365-RP

Nominal (1D) vs. Assembly Performance Indicators

Exterior Insulation 1D R-Value (RSI)	R_{1D} ft ² ·hr·°F / Btu (m ² K / W)	8" Vertical Clip Spacing		16" Vertical Clip Spacing		24" Vertical Clip Spacing	
		R_o ft ² ·hr·°F / Btu (m ² K / W)	U_o Btu/ft ² ·hr ·°F (W/m ² K)	R_o ft ² ·hr·°F / Btu (m ² K / W)	U_o Btu/ft ² ·hr ·°F (W/m ² K)	R_o ft ² ·hr·°F / Btu (m ² K / W)	U_o Btu/ft ² ·hr ·°F (W/m ² K)
R-4.2 (0.74)	R-8.5 (1.50)	R-7.4 (1.31)	0.134 (0.762)	R-7.9 (1.39)	0.127 (0.719)	R-8.1 (1.43)	0.123 (0.699)
R-8.4 (1.48)	R-12.7 (2.24)	R-9.8 (1.72)	0.103 (0.582)	R-11 (1.94)	0.091 (0.517)	R-11.6 (2.04)	0.086 (0.489)
R-12.6 (2.22)	R-16.9 (2.96)	R-11.6 (2.05)	0.086 (0.488)	R-13.6 (2.39)	0.074 (0.418)	R-14.6 (2.57)	0.068 (0.388)
R-16.8 (2.96)	R-21.1 (3.72)	R-13.3 (2.34)	0.075 (0.428)	R-15.9 (2.81)	0.063 (0.356)	R-17.6 (3.10)	0.057 (0.323)

Temperature Indices

	R4.2	R8.4	R12.6	R16.8	
T_{i1}	0.61	0.64	0.69	0.71	Min T on sheathing behind stud at Tie Penetration
T_{i2}	0.72	0.78	0.82	0.84	Max T on sheathing at edge of Steel Stud Flange aligned with Tie Penetration

Detail 5.1.75

Exterior Insulated 3 5/8" x 1 5/8" Steel Stud (16" o.c.) Wall Assembly with Hohmann & Barnard Masonry Stainless Steel HB-200-X Anchor Supporting Brick Veneer – Clear Wall

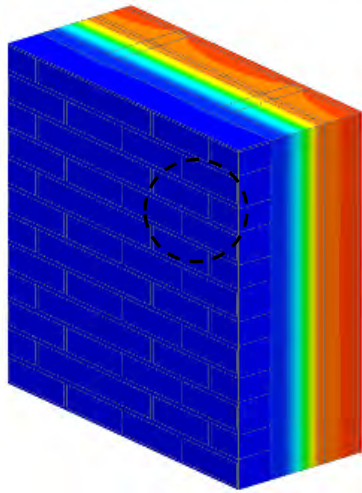

View of Exterior

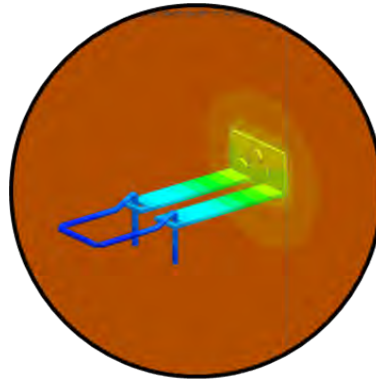

View of Anchoring Tie

Thermal Performance Indicators



Assembly 1D (Nominal) R-Value	R_{1D}	R-4.3 (0.76 RSI) + exterior insulation
Transmittance / Resistance	U_o , R_o	"Clear wall" U - and R -value
Surface Temperature Index ¹	T_i	0 = exterior temperature 1 = interior temperature

¹Assumptions and limitations for surface temperatures identified in ASHRAE 1365-RP

Nominal (1D) vs. Assembly Performance Indicators

Exterior Insulation 1D R-Value (RSI)	R_{1D} ft ² ·hr·°F / Btu (m ² K / W)	8" Vertical Clip Spacing		16" Vertical Clip Spacing		24" Vertical Clip Spacing	
		R_o ft ² ·hr·°F / Btu (m ² K / W)	U_o Btu/ft ² ·hr ·°F (W/m ² K)	R_o ft ² ·hr·°F / Btu (m ² K / W)	U_o Btu/ft ² ·hr ·°F (W/m ² K)	R_o ft ² ·hr·°F / Btu (m ² K / W)	U_o Btu/ft ² ·hr ·°F (W/m ² K)
R-4.2 (0.74)	R-8.5 (1.50)	R-7.7 (1.36)	0.130 (0.738)	R-8.1 (1.43)	0.123 (0.698)	R-8.2 (1.45)	0.121 (0.690)
R-8.4 (1.48)	R-12.7 (2.24)	R-10.6 (1.86)	0.094 (0.536)	R-11.7 (2.06)	0.085 (0.485)	R-12.0 (2.11)	0.084 (0.475)
R-12.6 (2.22)	R-16.9 (2.96)	R-13.5 (2.38)	0.074 (0.421)	R-15.1 (2.65)	0.066 (0.377)	R-15.4 (2.72)	0.065 (0.368)
R-16.8 (2.96)	R-21.1 (3.72)	R-16.2 (2.86)	0.062 (0.350)	R-18 (3.16)	0.056 (0.316)	R-18.9 (3.33)	0.053 (0.300)

Temperature Indices

	R4.2	R8.4	R12.6	R16.8	
T_{i1}	0.66	0.73	0.77	0.80	Min T on sheathing behind stud at Tie Penetration
T_{i2}	0.73	0.80	0.84	0.90	Max T on sheathing at edge of Steel Stud Flange aligned with Tie Penetration

Detail 5.1.76

Exterior Insulated 3 5/8" x 1 5/8" Steel Stud (16" o.c.) Wall Assembly with Hohmann & Barnard Masonry Carbon Steel BL-407 Anchor Supporting Brick Veneer – Clear Wall

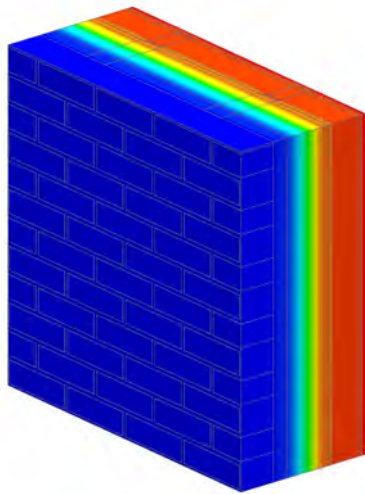

View from Interior

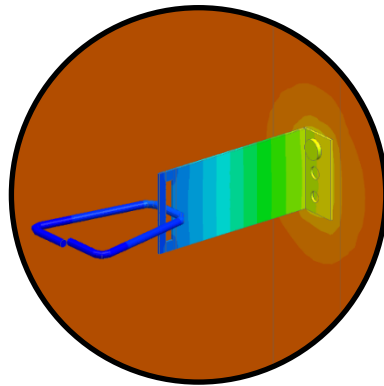

View of Anchoring Tie

Thermal Performance Indicators

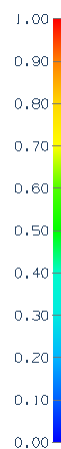

Assembly 1D (Nominal) R-Value	R_{1D}	R-4.3 (0.76 RSI) + exterior insulation
Transmittance / Resistance	U_o, R_o	“clear wall” U_o and R-value

¹Assumptions and limitations for surface temperatures identified in ASHRAE 1365-RP

Nominal (1D) vs. Assembly Performance Indicators

Exterior Insulation 1D R-Value (RSI)	R_{1D} ft ² ·hr·°F / Btu (m ² K / W)	8" Vertical Clip Spacing		16" Vertical Clip Spacing		24" Vertical Clip Spacing	
		R_o ft ² ·hr·°F / Btu (m ² K / W)	U_o Btu/ft ² ·hr ·°F (W/m ² K)	R_o ft ² ·hr·°F / Btu (m ² K / W)	U_o Btu/ft ² ·hr ·°F (W/m ² K)	R_o ft ² ·hr·°F / Btu (m ² K / W)	U_o Btu/ft ² ·hr ·°F (W/m ² K)
R-4.2 (0.74)	R-8.5 (1.50)	R-7.3 (1.29)	0.136 (0.77)	R-7.7 (1.36)	0.129 (0.73)	R-7.8 (1.38)	0.128 (0.73)
R-8.4 (1.48)	R-12.7 (2.24)	R-10.1 (1.78)	0.099 (0.56)	R-11.2 (1.97)	0.089 (0.51)	R-11.5 (2.02)	0.087 (0.50)
R-12.6 (2.22)	R-16.9 (2.98)	R-12.5 (2.21)	0.080 (0.45)	R-14.4 (2.54)	0.069 (0.39)	R-14.9 (2.62)	0.067 (0.38)
R-16.8 (2.96)	R-21.1 (3.72)	R-14.8 (2.61)	0.068 (0.38)	R-17.4 (3.07)	0.057 (0.33)	R-18.2 (3.20)	0.055 (0.31)
R-21.0 (3.70)	R-25.3 (4.46)	R-16.9 (2.97)	0.059 (0.34)	R-20.4 (3.58)	0.049 (0.28)	R-21.4 (3.77)	0.047 (0.26)
R-25.2 (4.44)	R-29.5 (5.20)	R-18.9 (3.33)	0.053 (0.30)	R-23.2 (4.08)	0.043 (0.24)	R-24.6 (4.33)	0.041 (0.23)
R-29.4 (5.18)	R-33.7 (5.94)	R-20.9 (3.67)	0.048 (0.27)	R-25.9 (4.57)	0.039 (0.22)	R-27.7 (4.87)	0.036 (0.21)

Detail 5.1.77

Exterior Insulated 3 5/8" x 1 5/8" Steel Stud (16" o.c.) Wall Assembly with Hohmann & Barnard Masonry Stainless Steel BL-407 Anchor Supporting Brick Veneer – Clear Wall

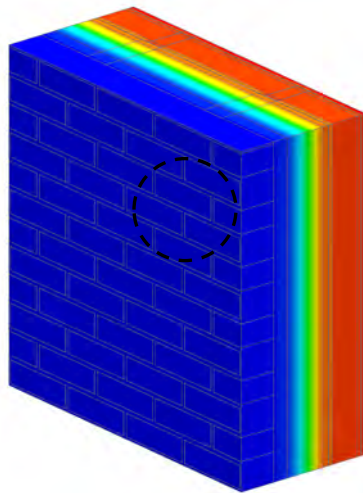

View of Exterior

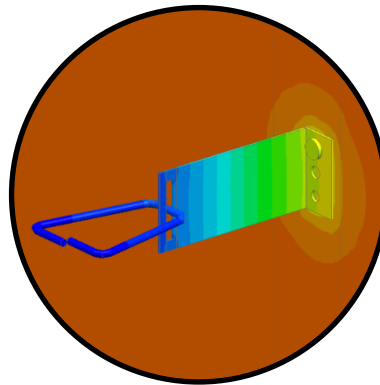

View of Anchoring Tie

Thermal Performance Indicators



Assembly 1D (Nominal) R-Value	R_{1D}	R-4.3 (0.76 RSI) + exterior insulation
Transmittance / Resistance	U_o , R_o	"Clear wall" U - and R -value
Surface Temperature Index ¹	T_i	0 = exterior temperature 1 = interior temperature

¹Assumptions and limitations for surface temperatures identified in ASHRAE 1365-RP

Nominal (1D) vs. Assembly Performance Indicators

Exterior Insulation 1D R-Value (RSI)	R_{1D} ft ² ·hr·°F / Btu (m ² K / W)	8" Vertical Clip Spacing		16" Vertical Clip Spacing		24" Vertical Clip Spacing	
		R_o ft ² ·hr·°F / Btu (m ² K / W)	U_o Btu/ft ² ·hr ·°F (W/m ² K)	R_o ft ² ·hr·°F / Btu (m ² K / W)	U_o Btu/ft ² ·hr ·°F (W/m ² K)	R_o ft ² ·hr·°F / Btu (m ² K / W)	U_o Btu/ft ² ·hr ·°F (W/m ² K)
R-4.2 (0.74)	R-8.5 (1.50)	R-7.6 (1.33)	0.132 (0.751)	R-7.8 (1.38)	0.127 (0.724)	R-7.9 (1.39)	0.126 (0.718)
R-8.4 (1.48)	R-12.7 (2.24)	R-10.8 (1.9)	0.093 (0.525)	R-11.6 (2.04)	0.087 (0.491)	R-11.8 (2.07)	0.085 (0.483)
R-12.6 (2.22)	R-16.9 (2.96)	R-13.9 (2.45)	0.072 (0.408)	R-15.1 (2.67)	0.066 (0.375)	R-15.5 (2.73)	0.065 (0.366)
R-16.8 (2.96)	R-21.1 (3.72)	R-16.9 (2.98)	0.059 (0.336)	R-18.7 (3.29)	0.054 (0.304)	R-19.2 (3.39)	0.052 (0.295)

Temperature Indices

	R4.2	R8.4	R12.6	R16.8	
T_{i1}	0.65	0.74	0.78	0.82	Min T on sheathing behind stud at Tie Penetration
T_{i2}	0.73	0.81	0.85	0.88	Max T on sheathing at edge of Steel Stud Flange aligned with Tie Penetration

Detail 5.1.78

Exterior and Interior Insulated 6" x 1 5/8" Steel Stud (16" o.c. and 24" o.c.) Wall Assembly with Stainless Steel Brick Anchors Supporting Brick Veneer and R-20 Batt Insulation in Stud Cavity – Clear Wall

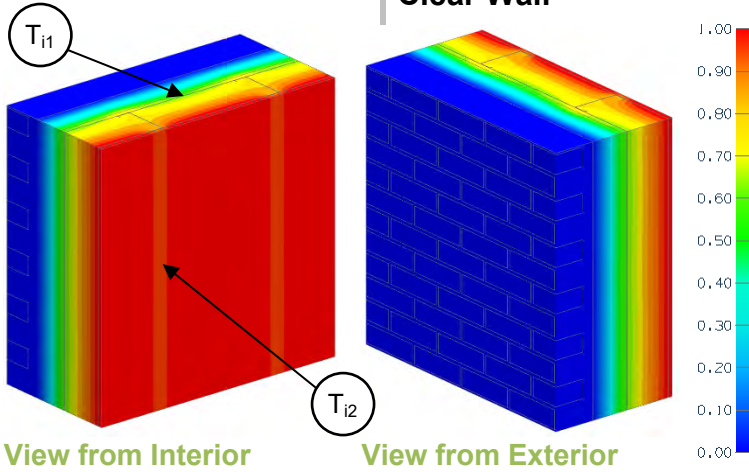

Thermal Performance Indicators

Assembly 1D (Nominal) R-Value	R_{1D}	R-23.4 (4.12 RSI) + exterior insulation
Transmittance / Resistance	U_o, R_o	"clear wall" U- and R-value
Surface Temperature Index ¹	T_i	0 = exterior temperature 1 = interior temperature

Nominal (1D) vs. Assembly Performance Indicators

Exterior Insulation 1D R-Value (RSI)	R_{1D} ft ² ·hr·°F / Btu (m ² K / W)	16" o.c.		24" o.c.	
		R_o ft ² ·hr·°F / Btu (m ² K / W)	U_o Btu/ft ² ·hr·°F (W/m ² K)	R_o ft ² ·hr·°F / Btu (m ² K / W)	U_o Btu/ft ² ·hr·°F (W/m ² K)
R-5.0 (0.88)	R-28.4 (5.01)	R-16.9 (2.97)	0.059 (0.34)	R-19.5 (3.44)	0.051 (0.29)
R-7.5 (1.32)	R-30.9 (5.45)	R-19.0 (3.35)	0.053 (0.30)	R-21.7 (3.83)	0.046 (0.26)
R-10.0 (1.76)	R-33.4 (5.89)	R-21.1 (3.71)	0.047 (0.27)	R-23.9 (4.21)	0.042 (0.24)
R-15.0 (2.64)	R-38.4 (6.77)	R-25.2 (4.44)	0.040 (0.23)	R-28.3 (4.98)	0.035 (0.20)
R-20.0 (3.52)	R-43.4 (7.65)	R-28.8 (5.07)	0.035 (0.20)	R-32.2 (5.68)	0.031 (0.18)
R-25.0 (4.40)	R-48.4 (8.53)	R-32.8 (5.77)	0.030 (0.17)	R-36.5 (6.43)	0.027 (0.16)
R-30.0 (5.28)	R-53.4 (9.41)	R-36.7 (6.47)	0.027 (0.15)	R-40.7 (7.18)	0.025 (0.14)
R-35.0 (6.16)	R-58.4 (10.29)	R-40.7 (7.17)	0.025 (0.14)	R-45.0 (7.92)	0.022 (0.13)

Temperature Indices

	R5	R7.5	R10	R15	R20	R25	R30	R35	
T_{i1}	0.30	0.37	0.43	0.52	0.61	0.65	0.69	0.72	Min T on sheathing, between studs
T_{i2}	0.57	0.62	0.66	0.72	0.75	0.78	0.80	0.82	Max T on sheathing, along studs

Temperature indices taken from scenario with 16" o.c. studs. All other scenarios have higher minimum temperature index.

Detail 5.1.79

Exterior and Interior Insulated 6" x 1 5/8" Steel Stud (16" o.c. and 24" o.c.) Wall Assembly with Steel Brick Anchors Supporting Brick Veneer and R-20 Batt Insulation in Stud Cavity – Clear Wall

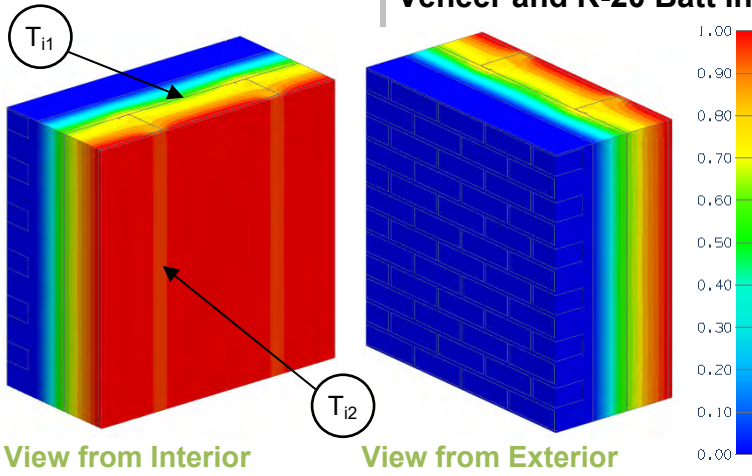

Thermal Performance Indicators

Assembly 1D (Nominal) R-Value	R_{1D}	R-23.4 (4.12 RSI) + exterior insulation
Transmittance / Resistance	U_o, R_o	"clear wall" U- and R-value
Surface Temperature Index ¹	T_i	0 = exterior temperature 1 = interior temperature

Nominal (1D) vs. Assembly Performance Indicators

Exterior Insulation 1D R-Value (RSI)	R_{1D} ft ² ·hr·°F / Btu (m ² K / W)	16" o.c.		24" o.c.	
		R_o ft ² ·hr·°F / Btu (m ² K / W)	U_o Btu/ft ² ·hr ·°F (W/m ² K)	R_o ft ² ·hr·°F / Btu (m ² K / W)	U_o Btu/ft ² ·hr ·°F (W/m ² K)
R-20.0 (3.52)	R-43.4 (7.65)	R-26.3 (4.62)	0.038 (0.22)	R-30.3 (5.34)	0.033 (0.19)
R-25.0 (4.40)	R-48.4 (8.53)	R-29.3 (5.17)	0.034 (0.19)	R-33.9 (5.97)	0.030 (0.17)
R-30.0 (5.28)	R-53.4 (9.41)	R-32.2 (5.68)	0.031 (0.18)	R-37.4 (6.58)	0.027 (0.15)
R-35.0 (6.16)	R-58.4 (10.29)	R-35.4 (6.23)	0.028 (0.16)	R-40.8 (7.19)	0.025 (0.14)

Temperature Indices

	R20	R25	R30	R35	
T_{i1}	0.59	0.62	0.65	0.68	Min T on sheathing, between studs
T_{i2}	0.72	0.75	0.77	0.79	Max T on sheathing, along studs

Temperature indices taken from scenario with 16" o.c. studs. All other scenarios have higher minimum temperature index.

Detail 5.1.80

Exterior Insulated 6" x 1 5/8" Steel Stud (16" o.c.) Wall Assembly with ECO Cladding Alpha Vci Vertical System – Clear Wall

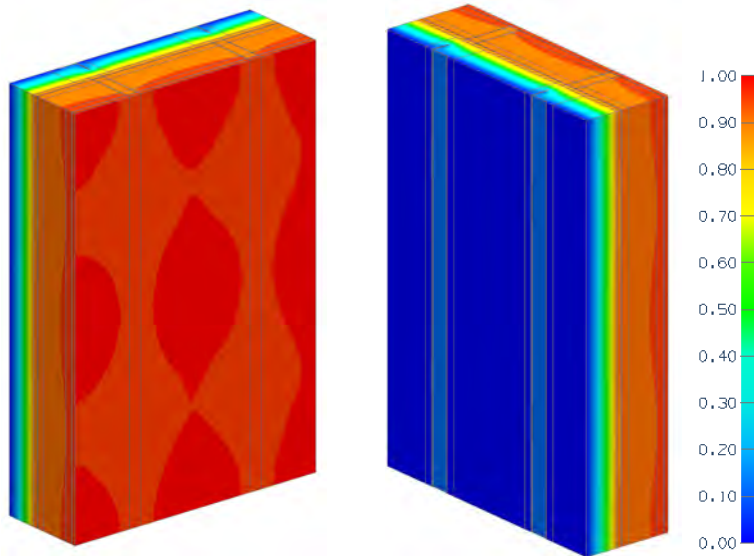

Thermal Performance Indicators

Assembly 1D (Nominal) R-Value	R_{1D}	R-3.3 (0.57 RSI) + exterior insulation
Transmittance / Resistance	U_o, R_o	"clear field" U- and R-values
Surface Temperature Index ¹	T_i	0 = exterior temperature 1 = interior temperature

¹Assumptions and limitations for surface temperatures identified in ASHRAE 1365-RP

View from Interior

View from Exterior

Nominal (1D) vs. Assembly Performance Indicators

16" Horizontal Clip Spacing

Exterior Insulation 1D R-value (RSI)	R_{1D} ft ² ·hr·°F / Btu (m ² K / W)	24" Vertical Spacing		36" Vertical Spacing	
		R_o ft ² ·hr·°F / Btu (m ² K / W)	U_o Btu/ft ² ·hr ·°F (W/m ² K)	R_o ft ² ·hr·°F / Btu (m ² K / W)	U_o Btu/ft ² ·hr ·°F (W/m ² K)
R-8.4 (1.48)	R-11.7 (2.05)	R-9.3 (1.64)	0.107 (0.609)	R-9.7 (1.72)	0.103 (0.583)
R-12.9 (2.28)	R-16.2 (2.85)	R-11.5 (2.02)	0.087 (0.494)	R-12.2 (2.16)	0.082 (0.464)
R-15.1 (2.66)	R-18.4 (3.23)	R-12.6 (2.21)	0.080 (0.452)	R-13.6 (2.39)	0.074 (0.419)
R-17.3 (3.04)	R-20.5 (3.61)	R-13.4 (2.35)	0.075 (0.425)	R-14.7 (2.58)	0.068 (0.387)
R-21.6 (3.80)	R-24.8 (4.37)	R-15.0 (2.64)	0.067 (0.379)	R-16.8 (2.96)	0.060 (0.338)
R-25.9 (4.56)	R-29.1 (5.13)	R-16.5 (2.91)	0.061 (0.344)	R-18.8 (3.31)	0.053 (0.302)

32" Horizontal and 24" Vertical Clip Spacing

Exterior Insulation 1D R-value (RSI)	R_{1D} ft ² ·hr·°F / Btu (m ² K / W)	R_o ft ² ·hr·°F / Btu (m ² K / W)	U_o Btu/ft ² ·hr ·°F (W/m ² K)
R-8.4 (1.48)	R-11.7 (2.05)	R-10.4 (1.83)	0.096 (0.547)
R-12.9 (2.28)	R-16.2 (2.85)	R-13.4 (2.37)	0.074 (0.422)
R-15.1 (2.66)	R-18.4 (3.23)	R-14.9 (2.63)	0.067 (0.381)
R-17.3 (3.04)	R-20.5 (3.61)	R-16.2 (2.85)	0.062 (0.351)
R-21.6 (3.80)	R-24.8 (4.37)	R-18.7 (3.29)	0.054 (0.304)
R-25.9 (4.56)	R-29.1 (5.13)	R-21.0 (3.70)	0.048 (0.270)

Detail 5.1.81

Exterior and Interior Insulated 6" x 1 5/8" Steel Stud (16" o.c.) Wall Assembly with ECO Cladding Alpha Vci Vertical System and R-19 Batt Insulation in Stud Cavity – Clear Wall

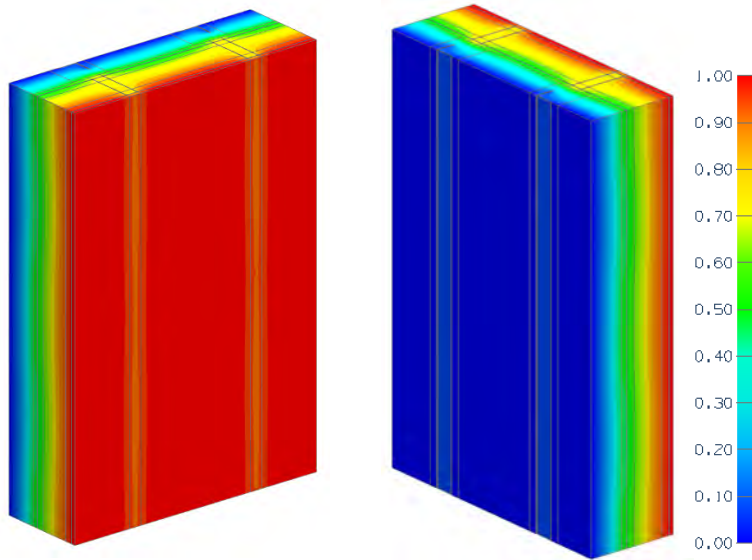

View from Interior

View from Exterior

Thermal Performance Indicators

Assembly 1D (Nominal) R-Value	R_{1D}	R-21.3 (3.75 RSI) + exterior insulation
Transmittance / Resistance	U_o, R_o	"clear field" U- and R-values
Surface Temperature Index ¹	T_i	0 = exterior temperature 1 = interior temperature

¹Assumptions and limitations for surface temperatures identified in ASHRAE 1365-RP

Nominal (1D) vs. Assembly Performance Indicators

16" Horizontal Clip Spacing

Exterior Insulation 1D R-value (RSI)	R_{1D} ft ² ·hr·°F / Btu (m ² K / W)	24" Vertical Spacing		36" Vertical Spacing	
		R_o ft ² ·hr·°F / Btu (m ² K / W)	U_o Btu/ft ² ·hr ·°F (W/m ² K)	R_o ft ² ·hr·°F / Btu (m ² K / W)	U_o Btu/ft ² ·hr ·°F (W/m ² K)
R-8.4 (1.48)	R-29.8 (5.24)	R-16.7 (2.94)	0.060 (0.340)	R-17.3 (3.05)	0.058 (0.328)
R-12.9 (2.28)	R-34.3 (6.04)	R-18.7 (3.29)	0.054 (0.304)	R-19.7 (3.47)	0.051 (0.288)
R-15.1 (2.66)	R-36.5 (6.42)	R-19.7 (3.47)	0.051 (0.288)	R-21.0 (3.70)	0.048 (0.270)
R-17.3 (3.04)	R-38.6 (6.80)	R-20.5 (3.61)	0.049 (0.277)	R-22.1 (3.90)	0.045 (0.257)
R-21.6 (3.80)	R-42.9 (7.56)	R-22.1 (3.89)	0.045 (0.257)	R-24.3 (4.28)	0.041 (0.234)
R-25.9 (4.56)	R-47.2 (8.32)	R-23.6 (4.16)	0.042 (0.240)	R-26.3 (4.63)	0.038 (0.216)

32" Horizontal and 24" Vertical Clip Spacing

Exterior Insulation 1D R-value (RSI)	R_{1D} ft ² ·hr·°F / Btu (m ² K / W)	R_o ft ² ·hr·°F / Btu (m ² K / W)	U_o Btu/ft ² ·hr ·°F (W/m ² K)
R-8.4 (1.48)	R-29.8 (5.24)	R-18.4 (3.23)	0.054 (0.309)
R-12.9 (2.28)	R-34.3 (6.04)	R-21.4 (3.76)	0.047 (0.266)
R-15.1 (2.66)	R-36.5 (6.42)	R-22.8 (4.02)	0.044 (0.249)
R-17.3 (3.04)	R-38.6 (6.80)	R-24.1 (4.25)	0.041 (0.235)
R-21.6 (3.80)	R-42.9 (7.56)	R-26.6 (4.69)	0.038 (0.213)
R-25.9 (4.56)	R-47.2 (8.32)	R-29.0 (5.11)	0.034 (0.196)

Detail 5.1.82

Exterior Insulated 6" x 1 5/8" Steel Stud (16" o.c.) Wall Assembly with ECO Cladding Alpha Hci Horizontal System – Clear Wall

Thermal Performance Indicators

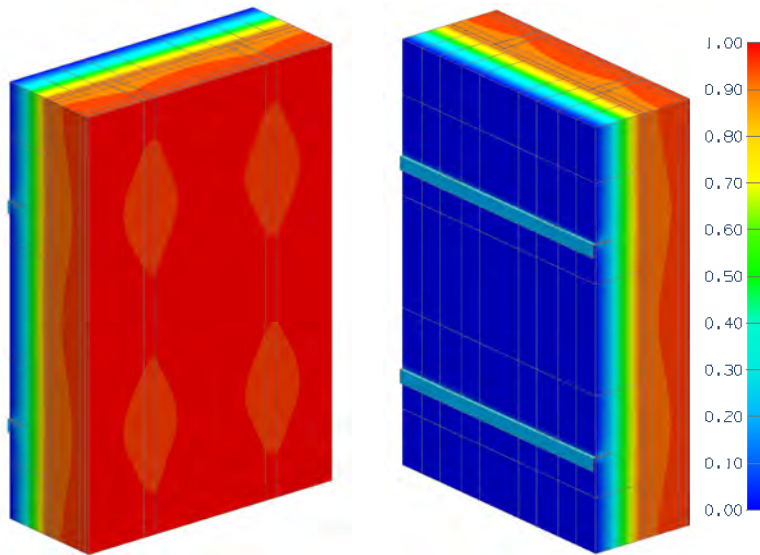

View from Interior

View from Exterior

Assembly 1D (Nominal) R-Value	R_{1D}	R-3.3 (0.57 RSI) + exterior insulation
Transmittance / Resistance	U_o , R_o	"clear field" U- and R-values
Surface Temperature Index ¹	T_i	0 = exterior temperature 1 = interior temperature

¹Assumptions and limitations for surface temperatures identified in ASHRAE 1365-RP

Nominal (1D) vs. Assembly Performance Indicators

16" Horizontal Clip Spacing

Exterior Insulation 1D R-value (RSI)	R_{1D} ft ² ·hr·°F / Btu (m ² K / W)	24" Vertical Spacing		36" Vertical Spacing	
		R_o ft ² ·hr·°F / Btu (m ² K / W)	U_o Btu/ft ² ·hr·°F (W/m ² K)	R_o ft ² ·hr·°F / Btu (m ² K / W)	U_o Btu/ft ² ·hr·°F (W/m ² K)
R-8.4 (1.48)	R-11.7 (2.05)	R-9.0 (1.58)	0.112 (0.633)	R-9.7 (1.71)	0.103 (0.584)
R-12.9 (2.28)	R-16.2 (2.85)	R-11.1 (1.95)	0.090 (0.512)	R-12.4 (2.18)	0.081 (0.459)
R-15.1 (2.66)	R-18.4 (3.23)	R-11.9 (2.09)	0.084 (0.478)	R-13.4 (2.37)	0.074 (0.423)
R-17.3 (3.04)	R-20.5 (3.61)	R-12.6 (2.21)	0.080 (0.452)	R-14.4 (2.53)	0.069 (0.395)
R-21.6 (3.80)	R-24.8 (4.37)	R-13.9 (2.45)	0.072 (0.408)	R-16.2 (2.86)	0.062 (0.350)
R-25.9 (4.56)	R-29.1 (5.13)	R-14.8 (2.61)	0.067 (0.383)	R-17.7 (3.11)	0.057 (0.322)

32" Horizontal and 24" Vertical Clip Spacing

Exterior Insulation 1D R-value (RSI)	R_{1D} ft ² ·hr·°F / Btu (m ² K / W)	R_o ft ² ·hr·°F / Btu (m ² K / W)	U_o Btu/ft ² ·hr·°F (W/m ² K)
R-8.4 (1.48)	R-11.7 (2.05)	R-9.9 (1.75)	0.101 (0.572)
R-12.9 (2.28)	R-16.2 (2.85)	R-12.6 (2.22)	0.079 (0.450)
R-15.1 (2.66)	R-18.4 (3.23)	R-13.8 (2.44)	0.072 (0.410)
R-17.3 (3.04)	R-20.5 (3.61)	R-14.8 (2.60)	0.068 (0.384)
R-21.6 (3.80)	R-24.8 (4.37)	R-17.1 (3.01)	0.059 (0.332)
R-25.9 (4.56)	R-29.1 (5.13)	R-18.8 (3.31)	0.053 (0.302)

Detail 5.1.83

Exterior and Interior Insulated 6" x 1 5/8" Steel Stud (16" o.c.) Wall Assembly with ECO Cladding Alpha Hci Horizontal System and R-19 Batt Insulation in Stud Cavity – Clear Wall

Thermal Performance Indicators

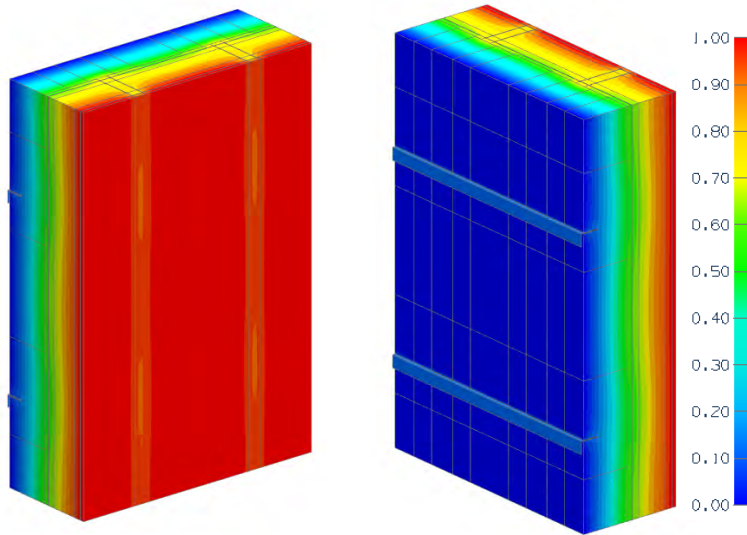

View from Interior

View from Exterior

Assembly 1D (Nominal) R-Value	R_{1D}	R-21.3 (3.75 RSI) + exterior insulation
Transmittance / Resistance	U_o, R_o	"clear field" U- and R-values
Surface Temperature Index ¹	T_i	0 = exterior temperature 1 = interior temperature

¹Assumptions and limitations for surface temperatures identified in ASHRAE 1365-RP

Nominal (1D) vs. Assembly Performance Indicators

16" Horizontal Clip Spacing

Exterior Insulation 1D R-value (RSI)	R_{1D} ft ² ·hr·°F / Btu (m ² K / W)	24" Vertical Spacing		36" Vertical Spacing	
		R_o ft ² ·hr·°F / Btu (m ² K / W)	U_o Btu/ft ² ·hr·°F (W/m ² K)	R_o ft ² ·hr·°F / Btu (m ² K / W)	U_o Btu/ft ² ·hr·°F (W/m ² K)
R-8.4 (1.48)	R-29.8 (5.24)	R-16.4 (2.90)	0.061 (0.345)	R-17.5 (3.08)	0.057 (0.324)
R-12.9 (2.28)	R-34.3 (6.04)	R-18.5 (3.25)	0.054 (0.308)	R-20.1 (3.54)	0.050 (0.282)
R-15.1 (2.66)	R-36.5 (6.42)	R-19.2 (3.38)	0.052 (0.296)	R-21.1 (3.72)	0.047 (0.269)
R-17.3 (3.04)	R-38.6 (6.80)	R-19.9 (3.50)	0.050 (0.286)	R-22.1 (3.89)	0.045 (0.257)
R-21.6 (3.80)	R-42.9 (7.56)	R-21.2 (3.73)	0.047 (0.268)	R-24.0 (4.22)	0.042 (0.237)
R-25.9 (4.56)	R-47.2 (8.32)	R-22.1 (3.90)	0.045 (0.256)	R-25.5 (4.48)	0.039 (0.223)

32" Horizontal and 24" Vertical Clip Spacing

Exterior Insulation 1D R-value (RSI)	R_{1D} ft ² ·hr·°F / Btu (m ² K / W)	R_o ft ² ·hr·°F / Btu (m ² K / W)	U_o Btu/ft ² ·hr·°F (W/m ² K)
R-8.4 (1.48)	R-29.8 (5.24)	R-18.0 (3.17)	0.055 (0.315)
R-12.9 (2.28)	R-34.3 (6.04)	R-20.7 (3.65)	0.048 (0.274)
R-15.1 (2.66)	R-36.5 (6.42)	R-22.0 (3.87)	0.046 (0.259)
R-17.3 (3.04)	R-38.6 (6.80)	R-23.0 (4.04)	0.044 (0.247)
R-21.6 (3.80)	R-42.9 (7.56)	R-25.4 (4.46)	0.039 (0.224)
R-25.9 (4.56)	R-47.2 (8.32)	R-27.2 (4.79)	0.037 (0.209)

Detail 5.1.84

Exterior Insulated 3 5/8" x 1 5/8" Steel Stud (16" O.C.) Wall Assembly with Armadillo FRR Horizontal Z-Girts Supporting Cladding – Clear Wall

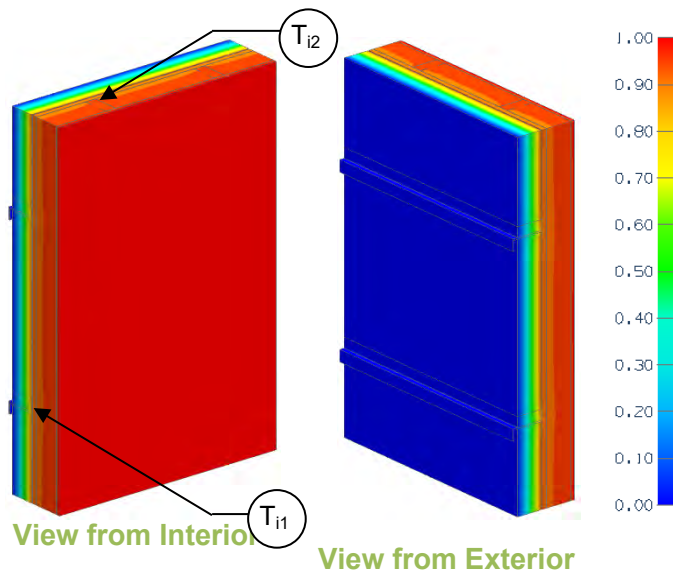

Thermal Performance Indicators

Assembly 1D (Nominal) R-Value	R_{1D}	R-3.3 (0.58 RSI) + exterior insulation
Transmittance / Resistance	U_o, R_o	"clear wall" U- and R-value
Surface Temperature Index ¹	T_i	0 = exterior temperature 1 = interior temperature

¹Assumptions and limitations for surface temperatures identified in ASHRAE 1365-RP

Nominal (1D) vs. Assembly Performance Indicators

Exterior Insulation 1D R-Value (RSI)	R_{1D} ft ² ·hr·°F / Btu (m ² K / W)	24" Vertical Girt Spacing		36" Vertical Girt Spacing		48" Vertical Girt Spacing	
		R_o ft ² ·hr·°F / Btu (m ² K / W)	U_o Btu/ft ² ·hr ·°F (W/m ² K)	R_o ft ² ·hr·°F / Btu (m ² K / W)	U_o Btu/ft ² ·hr ·°F (W/m ² K)	R_o ft ² ·hr·°F / Btu (m ² K / W)	U_o Btu/ft ² ·hr ·°F (W/m ² K)
R-5.0 (0.88)	R-8.3 (1.46)	R-8.3 (1.46)	0.121 (0.69)	R-8.2 (1.44)	0.122 (0.69)	R-8.2 (1.45)	0.122 (0.69)
R-10.0 (1.76)	R-13.3 (2.34)	R-12.9 (2.28)	0.077 (0.44)	R-13.0 (2.29)	0.077 (0.44)	R-13.1 (2.31)	0.076 (0.43)
R-15.0 (2.64)	R-18.3 (3.22)	R-17.6 (3.10)	0.057 (0.32)	R-17.9 (3.15)	0.056 (0.32)	R-18.0 (3.16)	0.056 (0.32)
R-20.0 (3.52)	R-23.3 (4.10)	R-22.3 (3.93)	0.045 (0.25)	R-22.7 (4.00)	0.044 (0.25)	R-22.8 (4.02)	0.044 (0.25)
R-25.0 (4.40)	R-28.3 (4.98)	R-27.0 (4.75)	0.037 (0.21)	R-27.5 (4.85)	0.036 (0.21)	R-27.7 (4.88)	0.036 (0.20)
R-30.0 (5.28)	R-33.3 (5.86)	R-31.6 (5.57)	0.032 (0.18)	R-32.4 (5.70)	0.031 (0.18)	R-32.6 (5.74)	0.031 (0.17)
R-35.0 (6.16)	R-38.3 (6.74)	R-36.3 (6.39)	0.028 (0.16)	R-37.2 (6.56)	0.027 (0.15)	R-37.5 (6.60)	0.027 (0.15)

Temperature Indices

	R5	R10	R15	R20	R25	R30	R35	
T_{i1}	0.75	0.84	0.88	0.90	0.92	0.93	0.94	Min T on sheathing, along girts between studs
T_{i2}	0.78	0.86	0.90	0.92	0.93	0.94	0.95	Max T on sheathing, along studs between girts

Detail 5.1.85

Exterior and Interior Insulated 3 5/8" x 1 5/8" Steel Stud (16" O.C.) Wall Assembly with Armadillo FRR Horizontal Z-Girts Supporting Cladding and R-13 Batt Insulation in Stud Cavity – Clear Wall

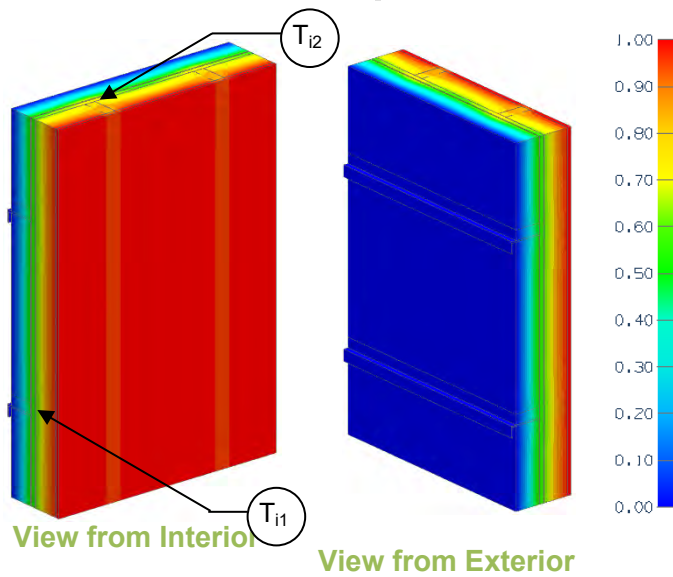

Thermal Performance Indicators

Assembly 1D (Nominal) R-Value	R_{1D}	R-15.4 (2.71 RSI) + exterior insulation
Transmittance / Resistance	U_o, R_o	"clear wall" U- and R-value
Surface Temperature Index ¹	T_i	0 = exterior temperature 1 = interior temperature

¹Assumptions and limitations for surface temperatures identified in ASHRAE 1365-RP

Nominal (1D) vs. Assembly Performance Indicators

Exterior Insulation 1D R-Value (RSI)	R_{1D} ft ² ·hr·°F / Btu (m ² K / W)	24" Vertical Girt Spacing		36" Vertical Girt Spacing		48" Vertical Girt Spacing	
		R_o ft ² ·hr·°F / Btu (m ² K / W)	U_o Btu/ft ² ·hr ·°F (W/m ² K)	R_o ft ² ·hr·°F / Btu (m ² K / W)	U_o Btu/ft ² ·hr ·°F (W/m ² K)	R_o ft ² ·hr·°F / Btu (m ² K / W)	U_o Btu/ft ² ·hr ·°F (W/m ² K)
R-5.0 (0.88)	R-20.4 (3.59)	R-14.9 (2.63)	0.067 (0.38)	R-15.0 (2.64)	0.067 (0.38)	R-15.0 (2.65)	0.067 (0.38)
R-10.0 (1.76)	R-25.4 (4.47)	R-19.7 (3.47)	0.051 (0.29)	R-19.8 (3.49)	0.050 (0.29)	R-19.9 (3.51)	0.050 (0.29)
R-15.0 (2.64)	R-30.4 (5.35)	R-24.5 (4.31)	0.041 (0.23)	R-24.7 (4.35)	0.041 (0.23)	R-24.8 (4.37)	0.040 (0.23)
R-20.0 (3.52)	R-35.4 (6.23)	R-29.3 (5.15)	0.034 (0.19)	R-29.5 (5.20)	0.034 (0.19)	R-29.7 (5.23)	0.034 (0.19)
R-25.0 (4.40)	R-40.4 (7.11)	R-34.0 (5.99)	0.029 (0.17)	R-34.4 (6.06)	0.029 (0.17)	R-34.6 (6.09)	0.029 (0.16)
R-30.0 (5.28)	R-45.4 (7.99)	R-38.8 (6.84)	0.026 (0.15)	R-39.2 (6.91)	0.025 (0.14)	R-39.5 (6.95)	0.025 (0.14)
R-35.0 (6.16)	R-50.4 (8.87)	R-43.6 (7.68)	0.023 (0.13)	R-44.1 (7.76)	0.023 (0.13)	R-44.4 (7.81)	0.023 (0.13)

Temperature Indices

	R5	R10	R15	R20	R25	R30	R35	
T_{i1}	0.32	0.48	0.58	0.65	0.70	0.73	0.76	Min T on sheathing, along girts between studs
T_{i2}	0.57	0.67	0.74	0.78	0.81	0.84	0.85	Max T on sheathing, along studs between girts

Detail 5.1.86

Exterior Insulated 3 5/8" x 1 5/8" Steel Stud (16" O.C.) Wall Assembly with Armadillo FRR Vertical Z-Girts Supporting Cladding – Clear Wall

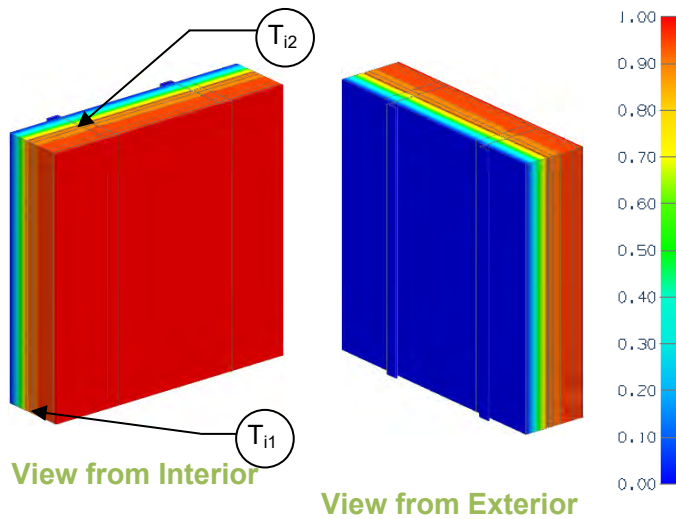

Thermal Performance Indicators

Assembly 1D (Nominal) R-Value	R_{1D}	R-3.3 (0.58 RSI) + exterior insulation
Transmittance / Resistance	U_o, R_o	“clear wall” U- and R-value
Surface Temperature Index ¹	T_i	0 = exterior temperature 1 = interior temperature

¹Assumptions and limitations for surface temperatures identified in ASHRAE 1365-RP

Nominal (1D) vs. Assembly Performance Indicators

Exterior Insulation 1D R-Value (RSI)	R_{1D} ft ² ·hr·°F / Btu (m ² K / W)	R_o ft ² ·hr·°F / Btu (m ² K / W)	U_o Btu/ft ² ·hr ·°F (W/m ² K)
R-5.0 (0.88)	R-8.3 (1.46)	R-8.0 (1.41)	0.125 (0.71)
R-10.0 (1.76)	R-13.3 (2.34)	R-12.6 (2.22)	0.079 (0.45)
R-15.0 (2.64)	R-18.3 (3.22)	R-17.2 (3.03)	0.058 (0.33)
R-20.0 (3.52)	R-23.3 (4.1)	R-21.8 (3.84)	0.046 (0.26)
R-25.0 (4.40)	R-28.3 (4.98)	R-26.4 (4.64)	0.038 (0.22)
R-30.0 (5.28)	R-33.3 (5.86)	R-31.0 (5.46)	0.032 (0.18)
R-35.0 (6.16)	R-38.3 (6.74)	R-35.6 (6.26)	0.028 (0.16)

Temperature Indices

	R5	R10	R15	R20	R25	R30	R35	
T_{i1}	0.75	0.84	0.88	0.91	0.92	0.93	0.93	Min T on sheathing, along girts between studs
T_{i2}	0.76	0.85	0.89	0.91	0.93	0.94	0.94	Max T on sheathing, along studs between girts

Detail 5.1.87

Exterior and Interior Insulated 3 5/8" x 1 5/8" Steel Stud (16" O.C.) Wall Assembly with Armadillo FRR Vertical Z-Girts Supporting Cladding and R-13 Batt Insulation in Stud Cavity – Clear Wall

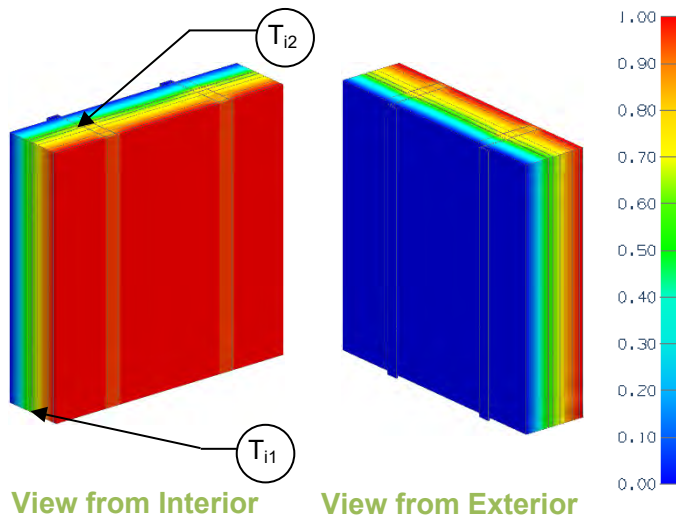

Thermal Performance Indicators

Assembly 1D (Nominal) R-Value	R_{1D}	R-15.4 (2.71 RSI) + exterior insulation
Transmittance / Resistance	U_o , R_o	“clear wall” U- and R-value
Surface Temperature Index ¹	T_i	0 = exterior temperature 1 = interior temperature

¹Assumptions and limitations for surface temperatures identified in ASHRAE 1365-RP

Nominal (1D) vs. Assembly Performance Indicators

Exterior Insulation 1D R-Value (RSI)	R_{1D} ft ² ·hr·°F / Btu (m ² K / W)	R_o ft ² ·hr·°F / Btu (m ² K / W)	U_o Btu/ft ² ·hr ·°F (W/m ² K)
R-5.0 (0.88)	R-20.4 (3.59)	R-14.6 (2.56)	0.069 (0.39)
R-10.0 (1.76)	R-25.4 (4.47)	R-19.1 (3.37)	0.052 (0.30)
R-15.0 (2.64)	R-30.4 (5.35)	R-23.7 (4.18)	0.042 (0.24)
R-20.0 (3.52)	R-35.4 (6.23)	R-28.3 (4.99)	0.035 (0.20)
R-25.0 (4.40)	R-40.4 (7.11)	R-32.9 (5.79)	0.030 (0.17)
R-30.0 (5.28)	R-45.4 (7.99)	R-37.5 (6.60)	0.027 (0.15)
R-35.0 (6.16)	R-50.4 (8.87)	R-42.1 (7.41)	0.024 (0.13)

Temperature Indices

	R5	R10	R15	R20	R25	R30	R35	
T_{i1}	0.36	0.51	0.60	0.67	0.71	0.75	0.78	Min T on sheathing, along girts between studs
T_{i2}	0.56	0.67	0.73	0.78	0.81	0.83	0.85	Max T on sheathing, along studs between girts

Detail 5.1.88

Exterior Insulated 3 5/8" x 1 5/8" Steel Stud (16" o.c.) Wall Assembly with Brick Ties (24" o.c.) Supporting Brick Veneer – Clear Wall

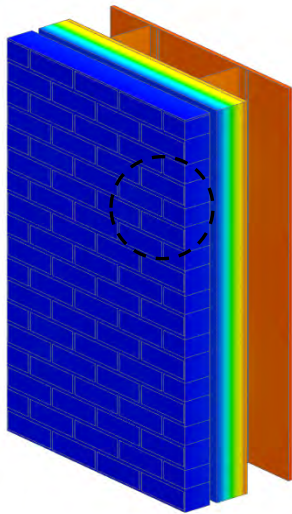

View of Exterior

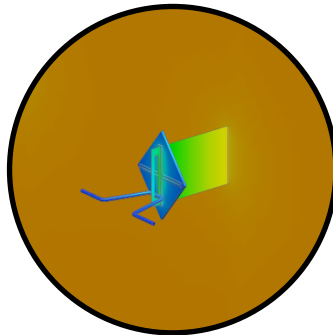

View of Anchoring Tie

Thermal Performance Indicators



Assembly 1D (Nominal) R-Value	R_{1D}	R-4.3 (0.76 RSI) + exterior insulation
Transmittance / Resistance	U_o , R_o	"Clear wall" U- and R-value

Nominal (1D) vs. Assembly Performance Indicators

Exterior Insulation 1D R-Value (RSI)	R_{1D} ft ² ·hr·°F / Btu (m ² K / W)	R_o ft ² ·hr·°F / Btu (m ² K / W)	U_o Btu/ft ² ·hr ·°F (W/m ² K)
R-16.8 (2.96)	R-21.1 (3.72)	R-16.1 (2.83)	0.062 (0.353)
R-24.0 (4.23)	R-28.3 (4.98)	R-19.8 (3.48)	0.051 (0.287)

Detail 5.1.89

Exterior Insulated 3 5/8" x 1 5/8" Steel Stud (16" o.c.) Wall Assembly with FERO Slotted Rap Ties (24" o.c.) Supporting Brick Veneer – Clear Wall

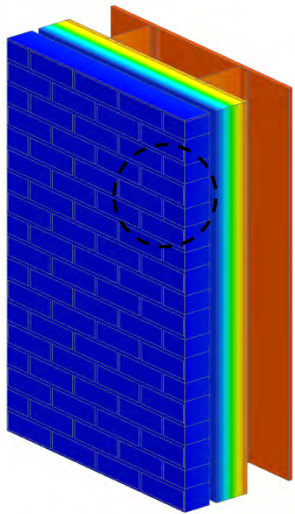

View of Exterior

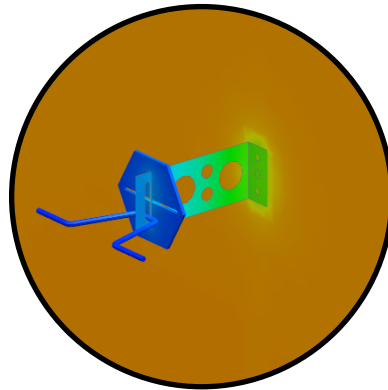

View of Anchoring Tie

Thermal Performance Indicators



Assembly 1D (Nominal) R-Value	R_{1D}	R-4.3 (0.76 RSI) + exterior insulation
Transmittance / Resistance	U_o , R_o	"Clear wall" U - and R-value

Nominal (1D) vs. Assembly Performance Indicators

Exterior Insulation 1D R-Value (RSI)	R_{1D} ft ² ·hr·°F / Btu (m ² K / W)	Without Aerogel		With Aerogel	
		R_o ft ² ·hr·°F / Btu (m ² K / W)	U_o Btu/ft ² ·hr ·°F (W/m ² K)	R_o ft ² ·hr·°F / Btu (m ² K / W)	U_o Btu/ft ² ·hr ·°F (W/m ² K)
R-16.8 (2.96)	R-21.1 (3.72)	R-18.6 (3.28)	0.054 (0.305)	R-18.8 (3.32)	0.053 (0.302)
R-24.0 (4.23)	R-28.3 (4.98)	R-24.1 (4.25)	0.041 (0.235)	R-24.5 (4.31)	0.041 (0.232)

Detail 5.1.90

Exterior Insulated 6" x 1 5/8" Steel Stud (16" O.C.) Wall Assembly with Fiber Reinforced Plastic Clip Supporting Cladding – Clear Wall

Thermal Performance Indicators

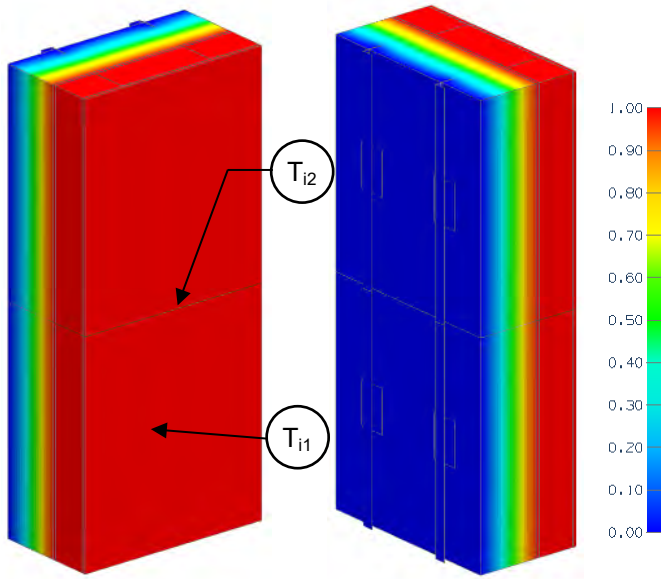

Assembly 1D (Nominal) R-Value	R_{1D}	R-3.2 (0.56) + insulation
Transmittance / Resistance without Anomaly	U_o, R_o	“clear field” U- and R-value, without connectors or joint
Point Transmittance	χ	Incremental increase in transmittance for connector
Surface Temperature Index ¹	T_i	0 = exterior temperature 1 = interior temperature

View from Interior View from Exterior

Nominal (1D) vs. Assembly Performance Indicators

Exterior Insulation 1D R-Value (RSI)	R_{1D} ft ² ·hr·°F / Btu (m ² K / W)	R_o ft ² ·hr·°F / Btu (m ² K / W)	U_o Btu/ft ² · hr ·°F (W/m ² K)
R-25.2 (4.44)	R-28.4 (5.00)	R-24.0 (4.23)	0.042 (0.24)
R-33.6 (5.92)	R-36.8 (6.48)	R-31.1 (5.47)	0.032 (0.18)
R-42.0 (7.40)	R-45.2 (7.96)	R-40.0 (7.04)	0.025 (0.14)

Temperature Indices

	R25.2	R33.6	R42.0	
T_{i1}	0.89	0.92	0.94	Min T on sheathing, at clip and stud intersection
T_{i2}	0.92	0.94	0.95	Max T on sheathing, center of stud cavity between clips

Detail 5.1.91

Exterior and Interior Insulated 6" x 1 5/8" Steel Stud (16" O.C.) Wall Assembly with Fiber Reinforced Plastic Clip Supporting Metal Cladding and R-19 Batt in Stud Cavity – Clear Wall

Thermal Performance Indicators

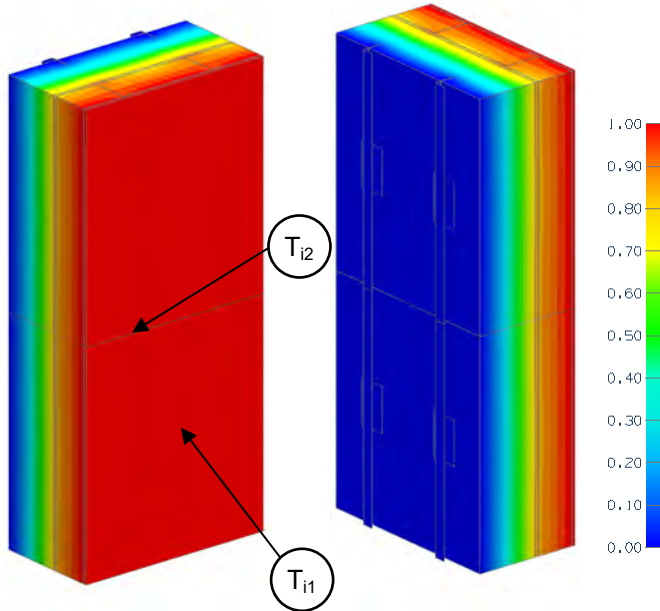

Assembly 1D (Nominal) R-Value	R_{1D}	R-21.3 (3.75) + insulation
Transmittance / Resistance without Anomaly	U_o, R_o	"clear field" U- and R-value, without connectors or joint
Point Transmittance	χ	Incremental increase in transmittance for connector
Surface Temperature Index ¹	T_i	0 = exterior temperature 1 = interior temperature

View from Interior View from Exterior

Nominal (1D) vs. Assembly Performance Indicators

Exterior Insulation 1D R-Value (RSI)	R_{1D} ft ² ·hr·°F / Btu (m ² K / W)	R_o ft ² ·hr·°F / Btu (m ² K / W)	U_o Btu/ft ² ·hr·°F (W/m ² K)
R-25.2 (4.44)	R-46.5 (8.19)	R-32.1 (5.66)	0.031 (0.18)
R-33.6 (5.92)	R-54.9 (9.67)	R-39.3 (6.91)	0.025 (0.15)
R-42.0 (7.40)	R-63.3 (11.15)	R-48.3 (8.50)	0.021 (0.12)

Temperature Indices

	R25.2	R33.6	R42.0	
T_{i1}	0.62	0.69	0.75	Min T on sheathing, between studs
T_{i2}	0.79	0.83	0.86	Max T on sheathing, at stud, between clips

Detail 5.1.92

Exterior Insulated 6" x 1 5/8" Steel Stud (16" O.C.) Wall Assembly with Double Aluminum Bracket Supporting Metal Cladding

Thermal Performance Indicators

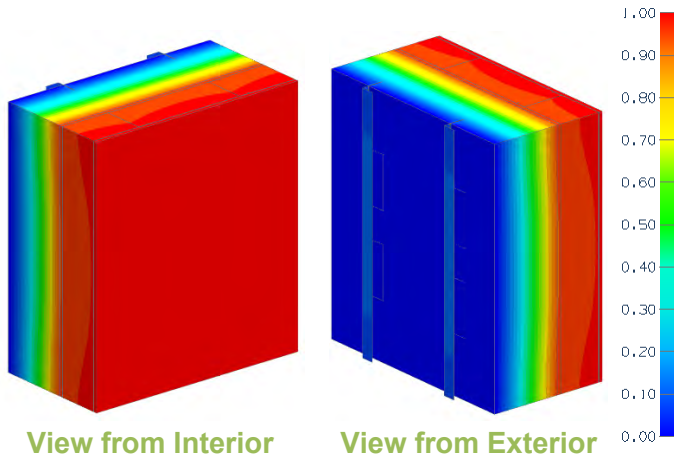

Assembly 1D (Nominal) R-Value	R_{1D}	R-3.2 (0.56) + insulation
Transmittance / Resistance	U, R	U- and R-values for overall assembly
Point Transmittance	χ	Incremental increase in transmittance for connector

Nominal (1D) vs. Assembly Performance Indicators

Exterior Insulation 1D R-Value (RSI)	R_{1D} ft ² ·hr·°F / Btu (m ² K / W)	R ft ² ·hr·°F / Btu (m ² K / W)	U Btu/ft ² ·hr·°F (W/m ² K)	χ Btu/hr·°F (W/K)
R-25.2 (4.44)	R-28.4 (5.00)	R-12.8 (2.25)	0.078 (0.44)	0.073 (0.038)
R-33.6 (5.92)	R-36.8 (6.48)	R-13.9 (2.44)	0.072 (0.41)	0.080 (0.042)
R-42.0 (7.40)	R-45.2 (7.96)	R-14.7 (2.60)	0.068 (0.39)	0.086 (0.045)

Detail 5.1.93

Exterior and Interior Insulated 6" x 1 5/8" Steel Stud (16" O.C.) Wall Assembly with Double Aluminum Bracket Supporting Metal Cladding and R-19 Batt Insulation in Stud Cavity

Thermal Performance Indicators

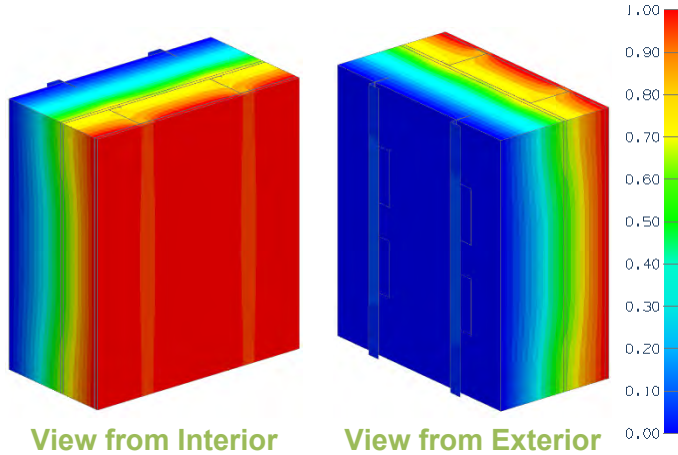

Assembly 1D (Nominal) R-Value	R_{1D}	R-21.3 (3.75) + insulation
Transmittance / Resistance	U, R	U- and R-values for overall assembly
Point Transmittance	χ	Incremental increase in transmittance for connector

Nominal (1D) vs. Assembly Performance Indicators

Exterior Insulation 1D R-Value (RSI)	R_{1D} ft ² ·hr·°F / Btu (m ² K / W)	R ft ² ·hr·°F / Btu (m ² K / W)	U Btu/ft ² ·hr·°F (W/m ² K)	χ Btu/hr·°F (W/K)
R-25.2 (4.44)	R-46.5 (8.19)	R-20.2 (3.55)	0.050 (0.28)	0.037 (0.020)
R-33.6 (5.92)	R-54.9 (9.67)	R-21.3 (3.75)	0.047 (0.27)	0.043 (0.023)
R-42.0 (7.40)	R-63.3 (11.15)	R-22.2 (3.90)	0.045 (0.26)	0.049 (0.026)

Detail 5.1.94

Exterior Insulated 6" x 1 5/8" Steel Stud (16" O.C.) Wall Assembly with Technoform Clip and Steel Fasteners - Clear Wall

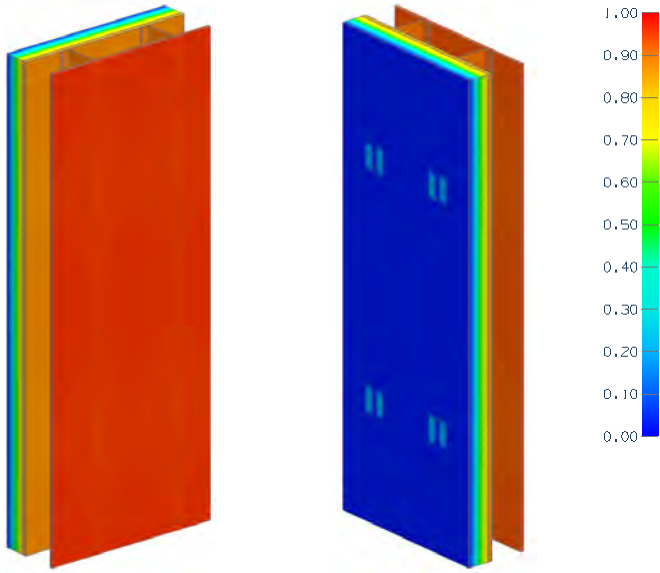

View from Interior

View from Exterior

Thermal Performance Indicators

Assembly 1D (Nominal) R-Value	R_{1D}	R-3.30 (0.58 RSI) + exterior insulation
Transmittance / Resistance	U_o , R_o	"Clear wall" U- and R-value

Nominal (1D) vs. Assembly Performance Indicators

Exterior Insulation 1D R-Value (RSI)	R_{1D} ft ² ·hr·°F / Btu (m ² K / W)	12" Vertical Clip Spacing		16" Vertical Clip Spacing		24" Vertical Clip Spacing		36" Vertical Clip Spacing		42" Vertical Clip Spacing	
		R_o ft ² ·hr·°F / Btu (m ² K / W)	U_o Btu/ft ² ·hr·°F (W/m ² K)	R_o ft ² ·hr·°F / Btu (m ² K / W)	U_o Btu/ft ² ·hr·°F (W/m ² K)	R_o ft ² ·hr·°F / Btu (m ² K / W)	U_o Btu/ft ² ·hr·°F (W/m ² K)	R_o ft ² ·hr·°F / Btu (m ² K / W)	U_o Btu/ft ² ·hr·°F (W/m ² K)	R_o ft ² ·hr·°F / Btu (m ² K / W)	U_o Btu/ft ² ·hr·°F (W/m ² K)
R-8.4 (1.48)	R-11.7 (2.06)	R-9.6 (1.70)	0.104 (0.59)	R-9.9 (1.75)	0.101 (0.57)	R-10.4 (1.83)	0.096 (0.55)	R-10.9 (1.92)	0.092 (0.52)	R-11.0 (1.94)	0.091 (0.51)
R-16.8 (2.96)	R-20.1 (3.54)	R-14.3 (2.51)	0.070 (0.40)	R-15.1 (2.65)	0.066 (0.38)	R-16.4 (2.88)	0.061 (0.35)	R-17.6 (3.11)	0.057 (0.32)	R-18.0 (3.16)	0.056 (0.32)
R-25.2 (4.44)	R-28.5 (5.02)	R-18.8 (3.31)	0.053 (0.30)	R-20.1 (3.54)	0.050 (0.28)	R-22.2 (3.91)	0.045 (0.26)	R-24.3 (4.28)	0.041 (0.23)	R-24.8 (4.37)	0.040 (0.23)
R-33.6 (5.92)	R-36.9 (6.50)	R-21.3 (3.76)	0.047 (0.27)	R-22.7 (4.00)	0.044 (0.25)	R-25.3 (4.46)	0.039 (0.22)	R-28.9 (5.08)	0.035 (0.20)	R-30.5 (5.36)	0.033 (0.19)

Detail 5.1.95

Exterior Insulated 6" x 1 5/8" Steel Stud (16" O.C.) Wall Assembly with Technoform Clip and Stainless Steel Fasteners - Clear Wall

Thermal Performance Indicators

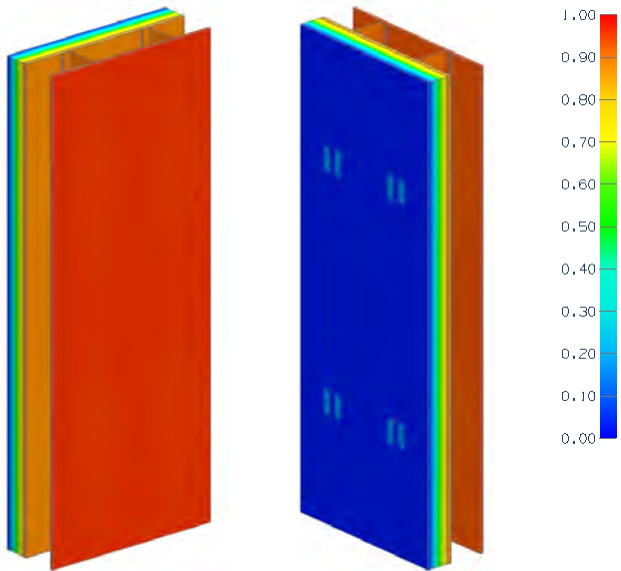

Assembly 1D (Nominal) R-Value	R_{1D}	R-3.30 (0.58 RSI) + exterior insulation
Transmittance / Resistance	U_o , R_o	"Clear wall" U- and R-value

View from Interior

View from Exterior

Nominal (1D) vs. Assembly Performance Indicators

Exterior Insulation 1D R-Value (RSI)	R_{1D} ft ² ·hr·°F / Btu (m ² K / W)	12" Vertical Clip Spacing		16" Vertical Clip Spacing		24" Vertical Clip Spacing		36" Vertical Clip Spacing		42" Vertical Clip Spacing	
		R_o ft ² ·hr·°F / Btu (m ² K / W)	U_o Btu/ft ² ·hr·°F (W/m ² K)	R_o ft ² ·hr·°F / Btu (m ² K / W)	U_o Btu/ft ² ·hr·°F (W/m ² K)	R_o ft ² ·hr·°F / Btu (m ² K / W)	U_o Btu/ft ² ·hr·°F (W/m ² K)	R_o ft ² ·hr·°F / Btu (m ² K / W)	U_o Btu/ft ² ·hr·°F (W/m ² K)	R_o ft ² ·hr·°F / Btu (m ² K / W)	U_o Btu/ft ² ·hr·°F (W/m ² K)
R-8.4 (1.48)	R-11.7 (2.06)	R-10.0 (1.76)	0.100 (0.57)	R-10.2 (1.80)	0.098 (0.56)	R-10.7 (1.88)	0.094 (0.53)	R-11.1 (1.95)	0.090 (0.51)	R-11.2 (1.97)	0.090 (0.51)
R-16.8 (2.96)	R-20.1 (3.54)	R-15.5 (2.73)	0.065 (0.37)	R-16.2 (2.85)	0.062 (0.35)	R-17.2 (3.04)	0.058 (0.33)	R-18.3 (3.22)	0.055 (0.31)	R-18.5 (3.26)	0.054 (0.31)
R-25.2 (4.44)	R-28.5 (5.02)	R-21.4 (3.77)	0.047 (0.27)	R-22.4 (3.95)	0.045 (0.25)	R-24.1 (4.24)	0.042 (0.24)	R-25.7 (4.52)	0.039 (0.22)	R-26.0 (4.59)	0.038 (0.22)
R-33.6 (5.92)	R-36.9 (6.50)	R-24.7 (4.34)	0.041 (0.23)	R-26.0 (4.57)	0.039 (0.22)	R-28.3 (4.99)	0.035 (0.20)	R-31.2 (5.49)	0.032 (0.18)	R-32.3 (5.69)	0.031 (0.18)

Detail 5.1.96

Exterior and Interior Insulated 6" x 1 5/8" Steel Stud (16" o.c.) Wall Assembly with Galvanized Horizontal Intermittent Clips (24" o.c.) Supporting Metal Cladding and Owens Corning R-20 Batt Insulation in Stud Cavity – Clear Wall

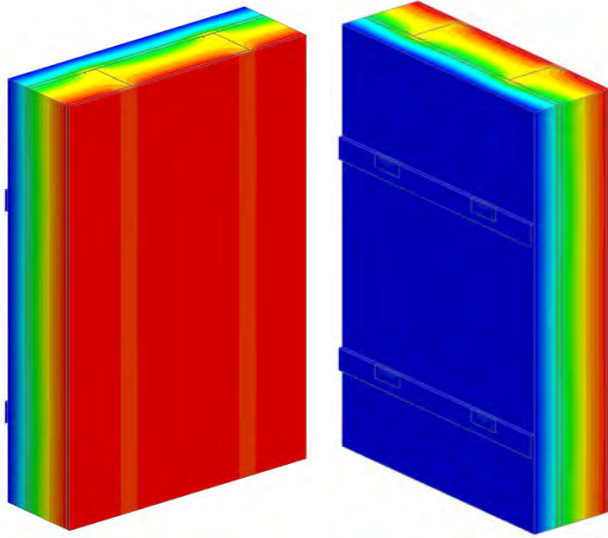

View from Interior

View from Exterior

Thermal Performance Indicators

Assembly 1D (Nominal) R-Value	R_{1D}	R-22.4 (3.94 RSI) + exterior insulation
Transmittance / Resistance without Anomaly	U_o , R_o	"clear wall" U- and R-value

¹Assumptions and limitations for surface temperatures identified in ASHRAE 1365-RP

Nominal (1D) vs. Assembly Performance Indicators

Exterior Insulation 1D R-Value (RSI)	R_{1D} ft ² ·hr·°F / Btu (m ² K / W)	R_o ft ² ·hr·°F / Btu (m ² K / W)	U_o Btu/ft ² ·hr ·°F (W/m ² K)
R-6.3 (1.11)	R-28.7 (5.05)	R-17.1 (3.02)	0.058 (0.33)
R-8.4 (1.48)	R-30.8 (5.42)	R-18.7 (3.29)	0.054 (0.30)
R-12.6 (2.22)	R-35.0 (6.16)	R-21.6 (3.80)	0.046 (0.26)
R-16.8 (2.96)	R-39.2 (6.90)	R-24.3 (4.27)	0.041 (0.23)
R-21.0 (3.70)	R-43.4 (7.64)	R-26.8 (4.72)	0.037 (0.21)

Detail 5.1.97

Exterior and Interior Insulated 6" x 1 5/8" Steel Stud (16" o.c.) Wall Assembly with Galvanized Horizontal Intermittent Clips (24" o.c.) Supporting Metal Cladding and Owens Corning R-22.5 Batt Insulation in Stud Cavity – Clear Wall

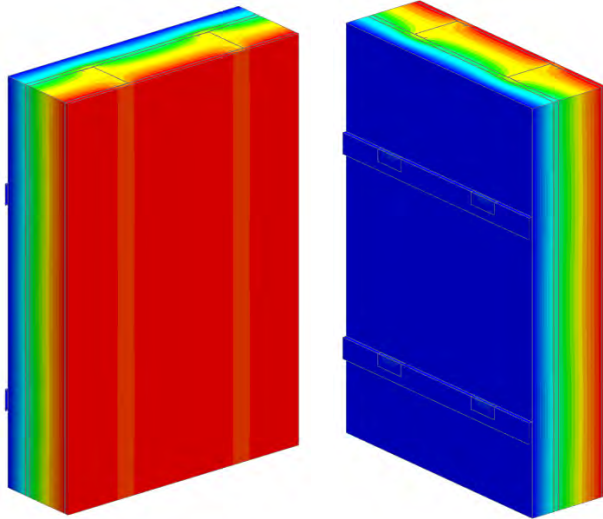

View from Interior

View from Exterior

Thermal Performance Indicators



Assembly 1D (Nominal) R-Value	R_{1D}	R-24.9 (4.38 RSI) + exterior insulation
Transmittance / Resistance without Anomaly	U_o, R_o	"clear wall" U- and R-value

¹Assumptions and limitations for surface temperatures identified in ASHRAE 1365-RP

Nominal (1D) vs. Assembly Performance Indicators

Exterior Insulation 1D R-Value (RSI)	R_{1D} ft ² ·hr·°F / Btu (m ² K / W)	R_o ft ² ·hr·°F / Btu (m ² K / W)	U_o Btu/ft ² ·hr ·°F (W/m ² K)
R-6.3 (1.11)	R-31.2 (5.49)	R-17.8 (3.13)	0.056 (0.32)
R-8.4 (1.48)	R-33.3 (5.86)	R-19.3 (3.40)	0.052 (0.29)
R-12.6 (2.22)	R-37.5 (6.60)	R-22.2 (3.91)	0.045 (0.26)
R-16.8 (2.96)	R-41.7 (7.34)	R-24.9 (4.38)	0.040 (0.23)
R-21.0 (3.70)	R-45.9 (8.08)	R-27.4 (4.83)	0.036 (0.21)

Detail 5.1.98

Exterior and Interior Insulated 6" x 1 5/8" Steel Stud (16" o.c.) Wall Assembly with Galvanized Horizontal Intermittent Clips (24" o.c.) Supporting Metal Cladding and Owens Corning R-24 Batt Insulation in Stud Cavity – Clear Wall

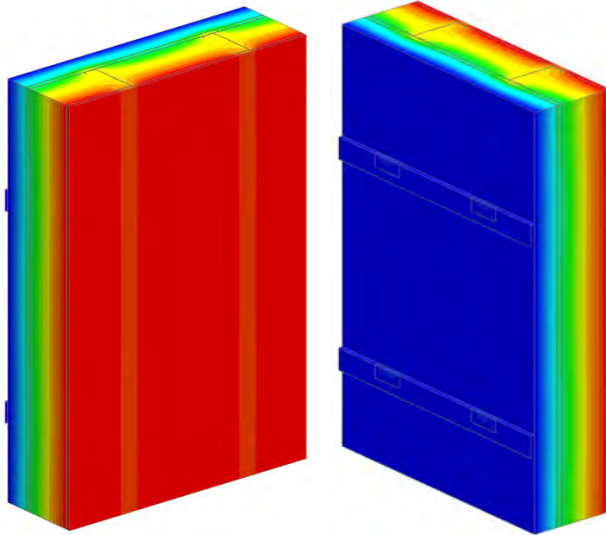

View from Interior

View from Exterior

Thermal Performance Indicators

Assembly 1D (Nominal) R-Value	R_{1D}	R-26.4 (4.65 RSI) + exterior insulation
Transmittance / Resistance without Anomaly	U_o , R_o	"clear wall" U- and R-value

¹Assumptions and limitations for surface temperatures identified in ASHRAE 1365-RP

Nominal (1D) vs. Assembly Performance Indicators

Exterior Insulation 1D R-Value (RSI)	R_{1D} ft ² ·hr·°F / Btu (m ² K / W)	R_o ft ² ·hr·°F / Btu (m ² K / W)	U_o Btu/ft ² ·hr·°F (W/m ² K)
R-6.3 (1.11)	R-32.7 (5.76)	R-18.1 (3.19)	0.055 (0.31)
R-8.4 (1.48)	R-34.8 (6.13)	R-19.6 (3.46)	0.051 (0.29)
R-12.6 (2.22)	R-39.0 (6.87)	R-22.5 (3.97)	0.044 (0.25)
R-16.8 (2.96)	R-43.2 (7.61)	R-25.2 (4.44)	0.040 (0.23)
R-21.0 (3.70)	R-47.4 (8.34)	R-27.8 (4.89)	0.036 (0.20)

Detail 5.1.99

Exterior Insulated 6" x 1 5/8" Steel Stud (16" o.c.) Wall Assembly with EJOT Crossfix Console and Horizontal Rail System Supporting Metal Cladding - Clear Wall

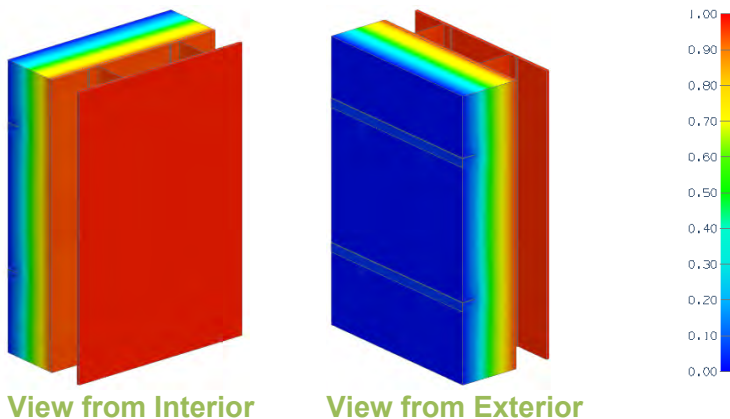

View from Interior

View from Exterior

Thermal Performance Indicators

Assembly 1D (Nominal) R-Value	R _{1D}	R-3.30 (0.58 RSI) + exterior insulation
Transmittance / Resistance	U _o , R _o	"Clear wall" U- and R- value

Nominal (1D) vs. Assembly Performance Indicators

16" Horizontal Console Spacing

Exterior Insulation 1D R-Value (RSI)	R _{1D} ft ² ·hr·°F / Btu (m ² K / W)	24" Vertical Clip Spacing		36" Vertical Clip Spacing		48" Vertical Clip Spacing	
		R _o ft ² ·hr·°F / Btu (m ² K / W)	U _o Btu/ft ² ·hr·°F (W/m ² K)	R _o ft ² ·hr·°F / Btu (m ² K / W)	U _o Btu/ft ² ·hr·°F (W/m ² K)	R _o ft ² ·hr·°F / Btu (m ² K / W)	U _o Btu/ft ² ·hr·°F (W/m ² K)
R-8.4 (1.48)	R-11.7 (2.06)	R-10.2 (1.80)	0.098 (0.55)	R-10.7 (1.88)	0.094 (0.53)	R-10.9 (1.92)	0.092 (0.52)
R-12.6 (2.22)	R-15.9 (2.80)	R-13.6 (2.39)	0.076 (0.43)	R-14.2 (2.51)	0.073 (0.41)	R-14.6 (2.58)	0.071 (0.40)
R-14.7 (2.59)	R-18.0 (3.17)	R-15.2 (2.68)	0.066 (0.37)	R-16.0 (2.82)	0.062 (0.35)	R-16.5 (2.90)	0.061 (0.34)
R-21.0 (3.70)	R-24.3 (4.28)	R-20.1 (3.54)	0.050 (0.28)	R-21.3 (3.76)	0.047 (0.27)	R-22.0 (3.88)	0.045 (0.26)
R-27.3 (4.81)	R-30.6 (5.39)	R-25.0 (4.40)	0.042 (0.24)	R-26.6 (4.69)	0.040 (0.22)	R-27.5 (4.85)	0.038 (0.22)
R-35.7 (6.29)	R-39.0 (6.87)	R-31.5 (5.55)	0.032 (0.18)	R-33.7 (5.93)	0.030 (0.17)	R-34.9 (6.14)	0.029 (0.16)
R-42.0 (7.40)	R-45.3 (7.98)	R-36.1 (6.36)	0.028 (0.16)	R-38.7 (6.82)	0.026 (0.15)	R-40.2 (7.08)	0.025 (0.14)
R-48.3 (8.51)	R-51.6 (9.08)	R-40.7 (7.18)	0.025 (0.14)	R-43.8 (7.72)	0.023 (0.13)	R-45.5 (8.02)	0.022 (0.13)
R-54.6 (9.62)	R-57.9 (10.19)	R-45.4 (7.99)	0.022 (0.13)	R-48.9 (8.61)	0.020 (0.12)	R-50.9 (8.96)	0.020 (0.11)
R-60.9 (10.73)	R-64.2 (11.30)	R-50.0 (8.80)	0.020 (0.11)	R-54.0 (9.50)	0.019 (0.11)	R-56.2 (9.90)	0.018 (0.10)
R-67.2 (11.84)	R-70.5 (12.41)	R-54.6 (9.61)	0.018 (0.10)	R-59.0 (10.39)	0.017 (0.10)	R-61.5 (10.84)	0.016 (0.09)

32" Horizontal Console Spacing

Exterior Insulation 1D R-Value (RSI)	R _{1D} ft ² ·hr·°F / Btu (m ² K / W)	24" Vertical Clip Spacing		36" Vertical Clip Spacing		48" Vertical Clip Spacing	
		R _o ft ² ·hr·°F / Btu (m ² K / W)	U _o Btu/ft ² ·hr·°F (W/m ² K)	R _o ft ² ·hr·°F / Btu (m ² K / W)	U _o Btu/ft ² ·hr·°F (W/m ² K)	R _o ft ² ·hr·°F / Btu (m ² K / W)	U _o Btu/ft ² ·hr·°F (W/m ² K)
R-8.4 (1.48)	R-11.7 (2.06)	R-10.7 (1.88)	0.094 (0.53)	R-11.0 (1.94)	0.091 (0.52)	R-11.2 (1.97)	0.090 (0.51)
R-12.6 (2.22)	R-15.9 (2.80)	R-14.2 (2.50)	0.073 (0.41)	R-14.7 (2.59)	0.071 (0.40)	R-15.0 (2.64)	0.069 (0.39)
R-14.7 (2.59)	R-18.0 (3.17)	R-16.0 (2.81)	0.063 (0.36)	R-16.6 (2.92)	0.060 (0.34)	R-16.9 (2.98)	0.059 (0.34)
R-21.0 (3.70)	R-24.3 (4.28)	R-21.5 (3.79)	0.046 (0.26)	R-22.4 (3.94)	0.045 (0.25)	R-22.8 (4.02)	0.044 (0.25)
R-27.3 (4.81)	R-30.6 (5.39)	R-27.0 (4.76)	0.039 (0.22)	R-28.1 (4.95)	0.038 (0.21)	R-28.7 (5.05)	0.037 (0.21)
R-35.7 (6.29)	R-39.0 (6.87)	R-34.4 (6.05)	0.029 (0.17)	R-35.8 (6.30)	0.028 (0.16)	R-36.5 (6.43)	0.027 (0.16)
R-42.0 (7.40)	R-45.3 (7.98)	R-39.7 (6.99)	0.025 (0.14)	R-41.4 (7.29)	0.024 (0.14)	R-42.3 (7.45)	0.024 (0.13)
R-48.3 (8.51)	R-51.6 (9.08)	R-45.0 (7.93)	0.023 (0.13)	R-47.0 (8.28)	0.022 (0.12)	R-48.1 (8.47)	0.021 (0.12)
R-54.6 (9.62)	R-57.9 (10.19)	R-50.4 (8.88)	0.020 (0.11)	R-52.6 (9.27)	0.019 (0.11)	R-53.9 (9.49)	0.019 (0.11)
R-60.9 (10.73)	R-64.2 (11.30)	R-55.7 (9.81)	0.018 (0.10)	R-58.3 (10.26)	0.017 (0.10)	R-59.6 (10.51)	0.017 (0.10)
R-67.2 (11.84)	R-70.5 (12.41)	R-61.0 (10.75)	0.016 (0.09)	R-63.9 (11.25)	0.016 (0.09)	R-65.4 (11.52)	0.015 (0.09)

Detail 5.1.100

Exterior and Interior Insulated 6" x 1 5/8" Steel Stud (16" o.c.) Wall Assembly with EJOT Crossfix Console and Horizontal Rail System Supporting Metal Cladding and R-20 Batt Insulation in Stud Cavity - Clear Wall

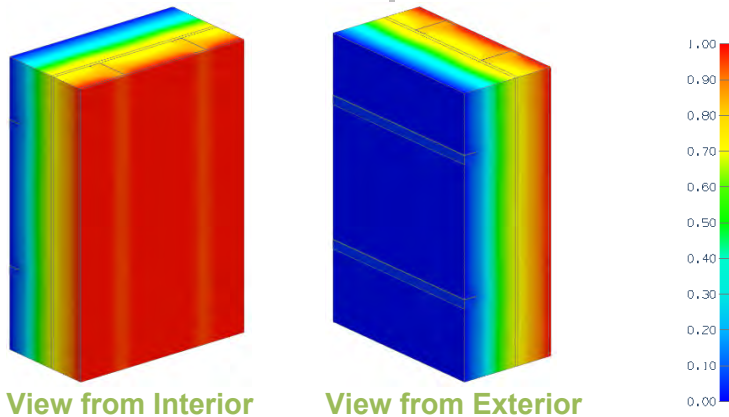

Thermal Performance Indicators

Assembly 1D (Nominal) R-Value	R_{1D}	R-22.4 (3.94 RSI) + exterior insulation
Transmittance / Resistance	U_o / R_o	"Clear wall" U- and R-value

Nominal (1D) vs. Assembly Performance Indicators

16" Horizontal Console Spacing

Exterior Insulation 1D R-Value (RSI)	R_{1D} ft ² ·hr·°F / Btu (m ² K / W)	24" Vertical Clip Spacing		36" Vertical Clip Spacing		48" Vertical Clip Spacing	
		R_o ft ² ·hr·°F / Btu (m ² K / W)	U_o Btu/ft ² ·hr ·°F (W/m ² K)	R_o ft ² ·hr·°F / Btu (m ² K / W)	U_o Btu/ft ² ·hr ·°F (W/m ² K)	R_o ft ² ·hr·°F / Btu (m ² K / W)	U_o Btu/ft ² ·hr ·°F (W/m ² K)
R-8.4 (1.48)	R-30.8 (5.42)	R-18.6 (3.27)	0.054 (0.31)	R-19.2 (3.39)	0.052 (0.30)	R-19.6 (3.45)	0.051 (0.29)
R-12.6 (2.22)	R-35.0 (6.16)	R-21.8 (3.85)	0.046 (0.26)	R-22.8 (4.01)	0.044 (0.25)	R-23.3 (4.10)	0.044 (0.25)
R-14.7 (2.59)	R-37.1 (6.53)	R-23.5 (4.14)	0.043 (0.24)	R-24.6 (4.33)	0.041 (0.23)	R-25.2 (4.43)	0.040 (0.23)
R-21.0 (3.70)	R-43.4 (7.64)	R-28.3 (4.98)	0.035 (0.20)	R-29.8 (5.24)	0.034 (0.19)	R-30.6 (5.39)	0.033 (0.19)
R-27.3 (4.81)	R-49.7 (8.75)	R-33.1 (5.83)	0.031 (0.18)	R-35.0 (6.17)	0.029 (0.17)	R-36.1 (6.35)	0.029 (0.16)
R-35.7 (6.29)	R-58.1 (10.23)	R-39.5 (6.96)	0.025 (0.14)	R-42.0 (7.40)	0.024 (0.14)	R-43.4 (7.64)	0.023 (0.13)
R-42.0 (7.40)	R-64.4 (11.34)	R-44.1 (7.77)	0.023 (0.13)	R-47.0 (8.29)	0.021 (0.12)	R-48.7 (8.58)	0.021 (0.12)
R-48.3 (8.51)	R-70.7 (12.45)	R-48.7 (8.58)	0.021 (0.12)	R-52.1 (9.18)	0.019 (0.11)	R-54.0 (9.51)	0.019 (0.11)
R-54.6 (9.62)	R-77.0 (13.56)	R-53.3 (9.39)	0.019 (0.11)	R-57.2 (10.07)	0.017 (0.10)	R-59.4 (10.45)	0.017 (0.10)
R-60.9 (10.73)	R-83.3 (14.67)	R-57.9 (10.20)	0.017 (0.10)	R-62.2 (10.96)	0.016 (0.09)	R-64.7 (11.39)	0.016 (0.09)
R-67.2 (11.84)	R-89.6 (15.78)	R-62.5 (11.01)	0.016 (0.09)	R-67.3 (11.85)	0.015 (0.08)	R-70.0 (12.33)	0.014 (0.08)

32" Horizontal Console Spacing

Exterior Insulation 1D R-Value (RSI)	R_{1D} ft ² ·hr·°F / Btu (m ² K / W)	24" Vertical Clip Spacing		36" Vertical Clip Spacing		48" Vertical Clip Spacing	
		R_o ft ² ·hr·°F / Btu (m ² K / W)	U_o Btu/ft ² ·hr ·°F (W/m ² K)	R_o ft ² ·hr·°F / Btu (m ² K / W)	U_o Btu/ft ² ·hr ·°F (W/m ² K)	R_o ft ² ·hr·°F / Btu (m ² K / W)	U_o Btu/ft ² ·hr ·°F (W/m ² K)
R-8.4 (1.48)	R-30.8 (5.42)	R-19.4 (3.41)	0.052 (0.29)	R-19.8 (3.49)	0.051 (0.29)	R-20.0 (3.53)	0.050 (0.28)
R-12.6 (2.22)	R-35.0 (6.16)	R-22.9 (4.03)	0.044 (0.25)	R-23.5 (4.14)	0.043 (0.24)	R-23.9 (4.21)	0.042 (0.24)
R-14.7 (2.59)	R-37.1 (6.53)	R-24.7 (4.34)	0.041 (0.23)	R-25.4 (4.47)	0.039 (0.22)	R-25.8 (4.55)	0.039 (0.22)
R-21.0 (3.70)	R-43.4 (7.64)	R-30.1 (5.31)	0.033 (0.19)	R-31.1 (5.49)	0.032 (0.18)	R-31.7 (5.58)	0.032 (0.18)
R-27.3 (4.81)	R-49.7 (8.75)	R-35.6 (6.27)	0.029 (0.16)	R-36.9 (6.49)	0.028 (0.16)	R-37.6 (6.61)	0.027 (0.16)
R-35.7 (6.29)	R-58.1 (10.23)	R-42.9 (7.56)	0.023 (0.13)	R-44.5 (7.84)	0.022 (0.13)	R-45.4 (7.99)	0.022 (0.13)
R-42.0 (7.40)	R-64.4 (11.34)	R-48.3 (8.50)	0.021 (0.12)	R-50.1 (8.83)	0.020 (0.11)	R-51.1 (9.01)	0.020 (0.11)
R-48.3 (8.51)	R-70.7 (12.45)	R-53.6 (9.44)	0.019 (0.11)	R-55.8 (9.82)	0.018 (0.10)	R-56.9 (10.02)	0.018 (0.10)
R-54.6 (9.62)	R-77.0 (13.56)	R-58.9 (10.38)	0.017 (0.10)	R-61.4 (10.81)	0.016 (0.09)	R-62.7 (11.04)	0.016 (0.09)
R-60.9 (10.73)	R-83.3 (14.67)	R-64.2 (11.31)	0.016 (0.09)	R-67.0 (11.80)	0.015 (0.09)	R-68.5 (12.06)	0.015 (0.08)
R-67.2 (11.84)	R-89.6 (15.78)	R-69.6 (12.25)	0.014 (0.08)	R-72.6 (12.79)	0.014 (0.08)	R-74.2 (13.07)	0.013 (0.08)

Detail 5.1.101

Exterior Insulated 6" x 1 5/8" Steel Stud (24" o.c.) Wall Assembly with EJOT Crossfix Console and Horizontal Rail System Supporting Metal Cladding - Clear Wall

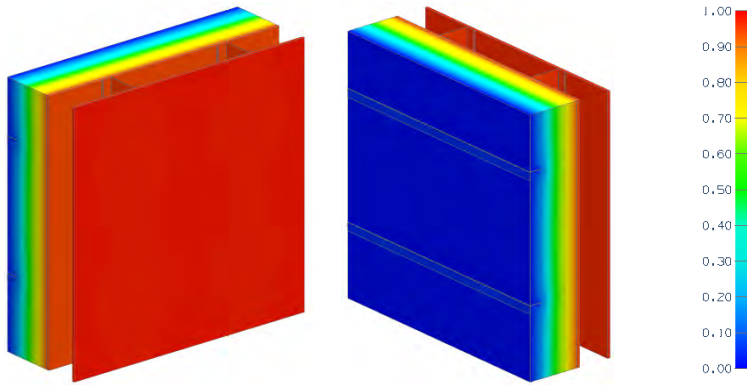

View from Interior

View from Exterior

Thermal Performance Indicators

Assembly 1D (Nominal) R-Value	R_{1D}	R-3.30 (0.58 RSI) + exterior insulation
Transmittance / Resistance	U_o , R_o	"Clear wall" U- and R-value

Nominal (1D) vs. Assembly Performance Indicators

Exterior Insulation 1D R-Value (RSI)	R_{1D} ft ² ·hr·°F / Btu (m ² K / W)	24" Vertical Clip Spacing		36" Vertical Clip Spacing		48" Vertical Clip Spacing	
		R_o ft ² ·hr·°F / Btu (m ² K / W)	U_o Btu/ft ² ·hr ·°F (W/m ² K)	R_o ft ² ·hr·°F / Btu (m ² K / W)	U_o Btu/ft ² ·hr ·°F (W/m ² K)	R_o ft ² ·hr·°F / Btu (m ² K / W)	U_o Btu/ft ² ·hr ·°F (W/m ² K)
R-8.4 (1.48)	R-11.7 (2.06)	R-10.5 (1.86)	0.095 (0.54)	R-10.9 (1.92)	0.092 (0.52)	R-11.1 (1.95)	0.090 (0.51)
R-12.6 (2.22)	R-15.9 (2.80)	R-14.0 (2.46)	0.074 (0.42)	R-14.6 (2.57)	0.071 (0.40)	R-14.9 (2.62)	0.070 (0.40)
R-14.7 (2.59)	R-18.0 (3.17)	R-15.7 (2.77)	0.064 (0.36)	R-16.4 (2.89)	0.061 (0.35)	R-16.8 (2.96)	0.060 (0.34)
R-21.0 (3.70)	R-24.3 (4.28)	R-21.0 (3.70)	0.048 (0.27)	R-22.0 (3.88)	0.045 (0.26)	R-22.6 (3.97)	0.044 (0.25)
R-27.3 (4.81)	R-30.6 (5.39)	R-26.3 (4.63)	0.040 (0.23)	R-27.6 (4.86)	0.038 (0.22)	R-28.3 (4.98)	0.037 (0.21)
R-35.7 (6.29)	R-39.0 (6.87)	R-33.3 (5.87)	0.030 (0.17)	R-35.0 (6.17)	0.029 (0.16)	R-36.0 (6.33)	0.028 (0.16)
R-42.0 (7.40)	R-45.3 (7.98)	R-38.4 (6.77)	0.026 (0.15)	R-40.5 (7.13)	0.025 (0.14)	R-41.6 (7.32)	0.024 (0.14)
R-48.3 (8.51)	R-51.6 (9.08)	R-43.5 (7.66)	0.023 (0.13)	R-45.9 (8.08)	0.022 (0.13)	R-47.2 (8.31)	0.021 (0.12)
R-54.6 (9.62)	R-57.9 (10.19)	R-48.6 (8.56)	0.021 (0.12)	R-51.3 (9.04)	0.019 (0.11)	R-52.8 (9.30)	0.019 (0.11)
R-60.9 (10.73)	R-64.2 (11.30)	R-53.7 (9.45)	0.019 (0.11)	R-56.8 (10.00)	0.018 (0.10)	R-58.4 (10.29)	0.017 (0.10)
R-67.2 (11.84)	R-70.5 (12.41)	R-58.7 (10.34)	0.017 (0.10)	R-62.2 (10.95)	0.016 (0.09)	R-64.1 (11.28)	0.016 (0.09)

Detail 5.1.102

Exterior and Interior Insulated 6" x 1 5/8" Steel Stud (24" o.c.) Wall Assembly with EJOT Crossfix Console and Horizontal Rail System Supporting Metal Cladding and R-20 Batt Insulation in Stud Cavity - Clear Wall

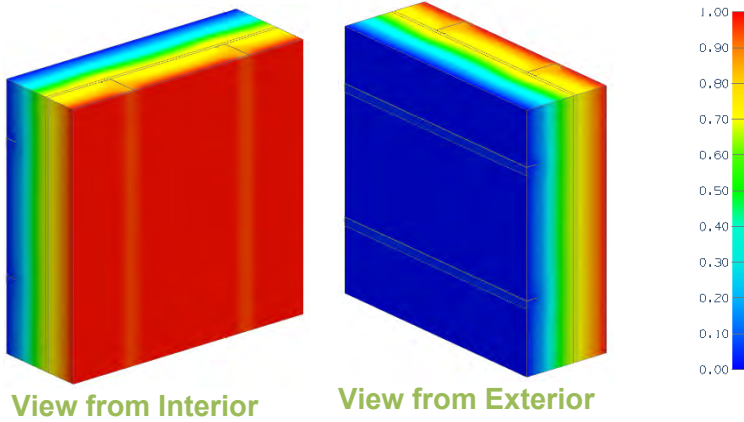

Thermal Performance Indicators

Assembly 1D (Nominal) R-Value	R_{1D}	R-22.4 (3.94 RSI) + exterior insulation
Transmittance / Resistance	U_o , R_o	"Clear wall" U- and R-value

Nominal (1D) vs. Assembly Performance Indicators

Exterior Insulation 1D R-Value (RSI)	R_{1D} ft ² ·hr·°F / Btu (m ² K / W)	24" Vertical Clip Spacing		36" Vertical Clip Spacing		48" Vertical Clip Spacing	
		R_o ft ² ·hr·°F / Btu (m ² K / W)	U_o Btu/ft ² ·hr·°F (W/m ² K)	R_o ft ² ·hr·°F / Btu (m ² K / W)	U_o Btu/ft ² ·hr·°F (W/m ² K)	R_o ft ² ·hr·°F / Btu (m ² K / W)	U_o Btu/ft ² ·hr·°F (W/m ² K)
R-8.4 (1.48)	R-30.8 (5.42)	R-21.3 (3.75)	0.047 (0.27)	R-21.9 (3.85)	0.046 (0.26)	R-22.2 (3.91)	0.045 (0.26)
R-12.6 (2.22)	R-35.0 (6.16)	R-24.7 (4.36)	0.041 (0.23)	R-25.6 (4.51)	0.040 (0.22)	R-26.0 (4.59)	0.039 (0.22)
R-14.7 (2.59)	R-37.1 (6.53)	R-26.5 (4.66)	0.038 (0.21)	R-27.5 (4.84)	0.036 (0.21)	R-28.0 (4.93)	0.036 (0.20)
R-21.0 (3.70)	R-43.4 (7.64)	R-31.7 (5.58)	0.032 (0.18)	R-33.0 (5.81)	0.030 (0.17)	R-33.7 (5.93)	0.030 (0.17)
R-27.3 (4.81)	R-49.7 (8.75)	R-36.9 (6.50)	0.028 (0.16)	R-38.5 (6.79)	0.027 (0.15)	R-39.4 (6.94)	0.026 (0.15)
R-35.7 (6.29)	R-58.1 (10.23)	R-43.9 (7.73)	0.023 (0.13)	R-45.9 (8.09)	0.022 (0.12)	R-47.0 (8.29)	0.021 (0.12)
R-42.0 (7.40)	R-64.4 (11.34)	R-48.9 (8.61)	0.020 (0.12)	R-51.3 (9.04)	0.019 (0.11)	R-52.6 (9.27)	0.019 (0.11)
R-48.3 (8.51)	R-70.7 (12.45)	R-53.9 (9.50)	0.019 (0.11)	R-56.7 (9.99)	0.018 (0.10)	R-58.3 (10.26)	0.017 (0.10)
R-54.6 (9.62)	R-77.0 (13.56)	R-59.0 (10.39)	0.017 (0.10)	R-62.2 (10.95)	0.016 (0.09)	R-63.9 (11.25)	0.016 (0.09)
R-60.9 (10.73)	R-83.3 (14.67)	R-64.1 (11.28)	0.016 (0.09)	R-67.6 (11.90)	0.015 (0.08)	R-69.5 (12.24)	0.014 (0.08)
R-67.2 (11.84)	R-89.6 (15.78)	R-69.1 (12.17)	0.014 (0.08)	R-73.0 (12.85)	0.014 (0.08)	R-75.1 (13.22)	0.013 (0.08)

Detail 5.1.103

Exterior Insulated 6" x 1 5/8" Steel Stud (16" o.c.) Wall Assembly with EJOT Crossfix Console and Vertical Rail System Supporting Metal Cladding - Clear Wall

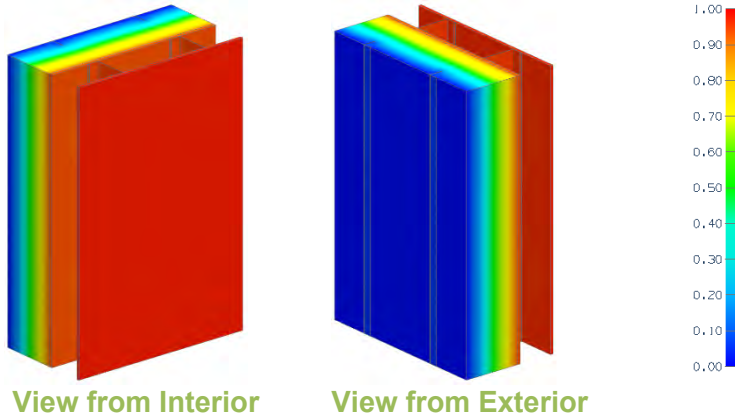

Thermal Performance Indicators

Assembly 1D (Nominal) R-Value	R _{1D}	R-3.30 (0.58 RSI) + exterior insulation
Transmittance / Resistance	U _o , R _o	"Clear wall" U- and R- value

View from Interior View from Exterior

Nominal (1D) vs. Assembly Performance Indicators

16" Horizontal Console Spacing

Exterior Insulation 1D R-Value (RSI)	R _{1D} ft ² ·hr·°F / Btu (m ² K / W)	24" Vertical Clip Spacing		36" Vertical Clip Spacing		48" Vertical Clip Spacing	
		R _o ft ² ·hr·°F / Btu (m ² K / W)	U _o Btu/ft ² ·hr·°F (W/m ² K)	R _o ft ² ·hr·°F / Btu (m ² K / W)	U _o Btu/ft ² ·hr·°F (W/m ² K)	R _o ft ² ·hr·°F / Btu (m ² K / W)	U _o Btu/ft ² ·hr·°F (W/m ² K)
R-8.4 (1.48)	R-11.7 (2.06)	R-10.0 (1.77)	0.100 (0.57)	R-10.3 (1.82)	0.097 (0.55)	R-10.5 (1.84)	0.096 (0.54)
R-12.6 (2.22)	R-15.9 (2.80)	R-12.9 (2.27)	0.080 (0.45)	R-13.4 (2.36)	0.077 (0.44)	R-13.6 (2.40)	0.076 (0.43)
R-14.7 (2.59)	R-18.0 (3.17)	R-14.3 (2.52)	0.070 (0.40)	R-14.9 (2.62)	0.067 (0.38)	R-15.2 (2.68)	0.066 (0.37)
R-21.0 (3.70)	R-24.3 (4.28)	R-19.1 (3.37)	0.052 (0.30)	R-20.1 (3.55)	0.050 (0.28)	R-20.7 (3.64)	0.048 (0.27)
R-27.3 (4.81)	R-30.6 (5.39)	R-23.8 (4.20)	0.044 (0.25)	R-25.3 (4.45)	0.042 (0.24)	R-26.1 (4.60)	0.040 (0.23)
R-35.7 (6.29)	R-39.0 (6.87)	R-30.2 (5.31)	0.033 (0.19)	R-32.2 (5.67)	0.031 (0.18)	R-33.3 (5.87)	0.030 (0.17)
R-42.0 (7.40)	R-45.3 (7.98)	R-34.7 (6.11)	0.029 (0.16)	R-37.2 (6.55)	0.027 (0.15)	R-38.6 (6.80)	0.026 (0.15)
R-48.3 (8.51)	R-51.6 (9.08)	R-39.4 (6.93)	0.026 (0.15)	R-42.3 (7.45)	0.024 (0.14)	R-44.0 (7.74)	0.023 (0.13)
R-54.6 (9.62)	R-57.9 (10.19)	R-44.0 (7.75)	0.023 (0.13)	R-47.4 (8.34)	0.021 (0.12)	R-49.3 (8.68)	0.020 (0.12)
R-60.9 (10.73)	R-64.2 (11.30)	R-48.6 (8.56)	0.021 (0.12)	R-52.4 (9.24)	0.019 (0.11)	R-54.6 (9.62)	0.018 (0.10)
R-67.2 (11.84)	R-70.5 (12.41)	R-53.2 (9.38)	0.019 (0.11)	R-57.5 (10.13)	0.017 (0.10)	R-60.0 (10.56)	0.017 (0.09)

32" Horizontal Console Spacing

Exterior Insulation 1D R-Value (RSI)	R _{1D} ft ² ·hr·°F / Btu (m ² K / W)	24" Vertical Clip Spacing		36" Vertical Clip Spacing		48" Vertical Clip Spacing	
		R _o ft ² ·hr·°F / Btu (m ² K / W)	U _o Btu/ft ² ·hr·°F (W/m ² K)	R _o ft ² ·hr·°F / Btu (m ² K / W)	U _o Btu/ft ² ·hr·°F (W/m ² K)	R _o ft ² ·hr·°F / Btu (m ² K / W)	U _o Btu/ft ² ·hr·°F (W/m ² K)
R-8.4 (1.48)	R-11.7 (2.06)	R-10.8 (1.90)	0.093 (0.53)	R-11.0 (1.93)	0.091 (0.52)	R-11.0 (1.94)	0.091 (0.51)
R-12.6 (2.22)	R-15.9 (2.80)	R-14.2 (2.51)	0.073 (0.41)	R-14.5 (2.56)	0.071 (0.40)	R-14.7 (2.58)	0.071 (0.40)
R-14.7 (2.59)	R-18.0 (3.17)	R-15.9 (2.81)	0.063 (0.36)	R-16.3 (2.87)	0.061 (0.35)	R-16.5 (2.90)	0.061 (0.34)
R-21.0 (3.70)	R-24.3 (4.28)	R-21.4 (3.77)	0.047 (0.27)	R-22.0 (3.88)	0.045 (0.26)	R-22.4 (3.94)	0.045 (0.25)
R-27.3 (4.81)	R-30.6 (5.39)	R-26.8 (4.72)	0.039 (0.22)	R-27.7 (4.88)	0.038 (0.22)	R-28.2 (4.96)	0.037 (0.21)
R-35.7 (6.29)	R-39.0 (6.87)	R-34.0 (5.99)	0.029 (0.17)	R-35.3 (6.21)	0.028 (0.16)	R-35.9 (6.33)	0.028 (0.16)
R-42.0 (7.40)	R-45.3 (7.98)	R-39.3 (6.92)	0.025 (0.14)	R-40.9 (7.19)	0.024 (0.14)	R-41.7 (7.34)	0.024 (0.14)
R-48.3 (8.51)	R-51.6 (9.08)	R-44.6 (7.86)	0.023 (0.13)	R-46.5 (8.19)	0.022 (0.12)	R-47.5 (8.36)	0.021 (0.12)
R-54.6 (9.62)	R-57.9 (10.19)	R-50.0 (8.80)	0.020 (0.11)	R-52.1 (9.18)	0.019 (0.11)	R-53.3 (9.38)	0.019 (0.11)
R-60.9 (10.73)	R-64.2 (11.30)	R-55.3 (9.74)	0.018 (0.10)	R-57.7 (10.17)	0.017 (0.10)	R-59.0 (10.39)	0.017 (0.10)
R-67.2 (11.84)	R-70.5 (12.41)	R-60.6 (10.68)	0.016 (0.09)	R-63.3 (11.16)	0.016 (0.09)	R-64.8 (11.41)	0.015 (0.09)

Detail 5.1.104

Exterior and Interior Insulated 6" x 1 5/8" Steel Stud (16" o.c.) Wall Assembly with EJOT Crossfix Console and Vertical Rail System Supporting Metal Cladding and R-20 Batt Insulation in Stud Cavity - Clear Wall

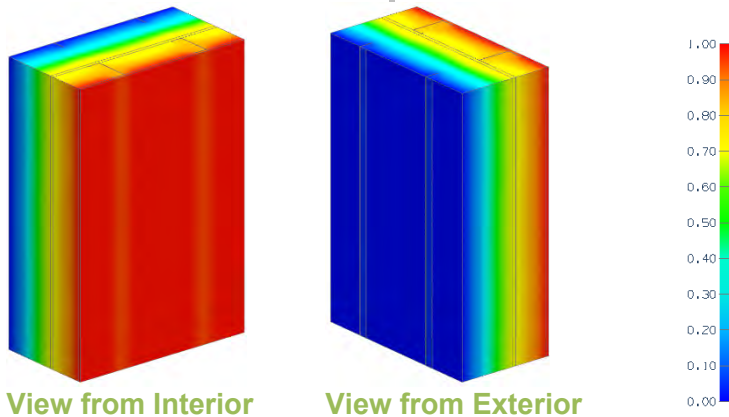

Thermal Performance Indicators

Assembly 1D (Nominal) R-Value	R_{1D}	R-22.4 (3.94 RSI) + exterior insulation
Transmittance / Resistance	U_o / R_o	"Clear wall" U- and R-value

Nominal (1D) vs. Assembly Performance Indicators

16" Horizontal Console Spacing

Exterior Insulation 1D R-Value (RSI)	R_{1D} ft ² ·hr·°F / Btu (m ² K / W)	24" Vertical Clip Spacing		36" Vertical Clip Spacing		48" Vertical Clip Spacing	
		R_o ft ² ·hr·°F / Btu (m ² K / W)	U_o Btu/ft ² ·hr ·°F (W/m ² K)	R_o ft ² ·hr·°F / Btu (m ² K / W)	U_o Btu/ft ² ·hr ·°F (W/m ² K)	R_o ft ² ·hr·°F / Btu (m ² K / W)	U_o Btu/ft ² ·hr ·°F (W/m ² K)
R-8.4 (1.48)	R-30.8 (5.42)	R-18.0 (3.17)	0.056 (0.32)	R-18.5 (3.25)	0.054 (0.31)	R-18.7 (3.30)	0.053 (0.30)
R-12.6 (2.22)	R-35.0 (6.16)	R-20.8 (3.66)	0.049 (0.28)	R-21.5 (3.78)	0.047 (0.27)	R-21.8 (3.85)	0.046 (0.26)
R-14.7 (2.59)	R-37.1 (6.53)	R-22.2 (3.90)	0.045 (0.26)	R-23.0 (4.05)	0.044 (0.25)	R-23.4 (4.12)	0.043 (0.24)
R-21.0 (3.70)	R-43.4 (7.64)	R-27.0 (4.76)	0.037 (0.21)	R-28.3 (4.98)	0.035 (0.20)	R-29.0 (5.11)	0.034 (0.20)
R-27.3 (4.81)	R-49.7 (8.75)	R-31.7 (5.59)	0.032 (0.18)	R-33.5 (5.90)	0.031 (0.17)	R-34.5 (6.08)	0.030 (0.17)
R-35.7 (6.29)	R-58.1 (10.23)	R-38.1 (6.70)	0.026 (0.15)	R-40.4 (7.12)	0.025 (0.14)	R-41.8 (7.36)	0.024 (0.14)
R-42.0 (7.40)	R-64.4 (11.34)	R-42.6 (7.51)	0.023 (0.13)	R-45.5 (8.01)	0.022 (0.12)	R-47.1 (8.29)	0.021 (0.12)
R-48.3 (8.51)	R-70.7 (12.45)	R-47.3 (8.32)	0.021 (0.12)	R-50.6 (8.90)	0.020 (0.11)	R-52.4 (9.23)	0.019 (0.11)
R-54.6 (9.62)	R-77.0 (13.56)	R-51.9 (9.14)	0.019 (0.11)	R-55.6 (9.80)	0.018 (0.10)	R-57.8 (10.17)	0.017 (0.10)
R-60.9 (10.73)	R-83.3 (14.67)	R-56.5 (9.96)	0.018 (0.10)	R-60.7 (10.69)	0.017 (0.09)	R-63.1 (11.11)	0.016 (0.09)
R-67.2 (11.84)	R-89.6 (15.78)	R-61.2 (10.77)	0.016 (0.09)	R-65.8 (11.59)	0.015 (0.09)	R-68.5 (12.06)	0.015 (0.08)

32" Horizontal Console Spacing

Exterior Insulation 1D R-Value (RSI)	R_{1D} ft ² ·hr·°F / Btu (m ² K / W)	24" Vertical Clip Spacing		36" Vertical Clip Spacing		48" Vertical Clip Spacing	
		R_o ft ² ·hr·°F / Btu (m ² K / W)	U_o Btu/ft ² ·hr ·°F (W/m ² K)	R_o ft ² ·hr·°F / Btu (m ² K / W)	U_o Btu/ft ² ·hr ·°F (W/m ² K)	R_o ft ² ·hr·°F / Btu (m ² K / W)	U_o Btu/ft ² ·hr ·°F (W/m ² K)
R-8.4 (1.48)	R-30.8 (5.42)	R-19.3 (3.39)	0.052 (0.29)	R-19.5 (3.44)	0.051 (0.29)	R-19.7 (3.47)	0.051 (0.29)
R-12.6 (2.22)	R-35.0 (6.16)	R-22.7 (4.00)	0.045 (0.25)	R-23.1 (4.07)	0.044 (0.25)	R-23.3 (4.11)	0.043 (0.25)
R-14.7 (2.59)	R-37.1 (6.53)	R-24.4 (4.30)	0.041 (0.23)	R-24.9 (4.38)	0.040 (0.23)	R-25.1 (4.43)	0.040 (0.23)
R-21.0 (3.70)	R-43.4 (7.64)	R-29.9 (5.26)	0.033 (0.19)	R-30.7 (5.40)	0.033 (0.19)	R-31.1 (5.47)	0.032 (0.18)
R-27.3 (4.81)	R-49.7 (8.75)	R-35.3 (6.21)	0.029 (0.17)	R-36.4 (6.40)	0.028 (0.16)	R-36.9 (6.50)	0.028 (0.16)
R-35.7 (6.29)	R-58.1 (10.23)	R-42.5 (7.49)	0.024 (0.13)	R-43.9 (7.74)	0.023 (0.13)	R-44.7 (7.88)	0.022 (0.13)
R-42.0 (7.40)	R-64.4 (11.34)	R-47.8 (8.42)	0.021 (0.12)	R-49.5 (8.73)	0.020 (0.11)	R-50.5 (8.89)	0.020 (0.11)
R-48.3 (8.51)	R-70.7 (12.45)	R-53.1 (9.36)	0.019 (0.11)	R-55.2 (9.72)	0.018 (0.10)	R-56.3 (9.91)	0.018 (0.10)
R-54.6 (9.62)	R-77.0 (13.56)	R-58.5 (10.30)	0.017 (0.10)	R-60.8 (10.71)	0.016 (0.09)	R-62.1 (10.93)	0.016 (0.09)
R-60.9 (10.73)	R-83.3 (14.67)	R-63.8 (11.24)	0.016 (0.09)	R-66.4 (11.70)	0.015 (0.09)	R-67.8 (11.95)	0.015 (0.08)
R-67.2 (11.84)	R-89.6 (15.78)	R-69.2 (12.18)	0.014 (0.08)	R-72.0 (12.69)	0.014 (0.08)	R-73.6 (12.96)	0.014 (0.08)

Detail 5.1.105

Exterior Insulated 6" x 1 5/8" Steel Stud (24" o.c.) Wall Assembly with EJOT Crossfix Console and Vertical Rail System Supporting Metal Cladding - Clear Wall

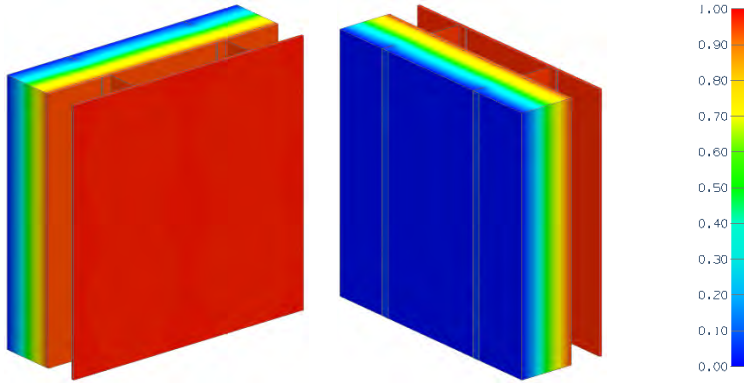

View from Interior

View from Exterior

Thermal Performance Indicators

Assembly 1D (Nominal) R-Value	R _{1D}	R-3.30 (0.58 RSI) + exterior insulation
Transmittance / Resistance	U _o , R _o	"Clear wall" U- and R-value

Nominal (1D) vs. Assembly Performance Indicators

Exterior Insulation 1D R-Value (RSI)	R _{1D} ft ² ·hr·°F / Btu (m ² K / W)	24" Vertical Clip Spacing		36" Vertical Clip Spacing		48" Vertical Clip Spacing	
		R _o ft ² ·hr·°F / Btu (m ² K / W)	U _o Btu/ft ² ·hr ·°F (W/m ² K)	R _o ft ² ·hr·°F / Btu (m ² K / W)	U _o Btu/ft ² ·hr ·°F (W/m ² K)	R _o ft ² ·hr·°F / Btu (m ² K / W)	U _o Btu/ft ² ·hr ·°F (W/m ² K)
R-8.4 (1.48)	R-11.7 (2.06)	R-10.5 (1.86)	0.095 (0.54)	R-10.7 (1.89)	0.093 (0.53)	R-10.9 (1.91)	0.092 (0.52)
R-12.6 (2.22)	R-15.9 (2.80)	R-13.8 (2.42)	0.075 (0.43)	R-14.1 (2.49)	0.073 (0.42)	R-14.3 (2.52)	0.072 (0.41)
R-14.7 (2.59)	R-18.0 (3.17)	R-15.4 (2.71)	0.065 (0.37)	R-15.8 (2.79)	0.063 (0.36)	R-16.1 (2.83)	0.062 (0.35)
R-21.0 (3.70)	R-24.3 (4.28)	R-20.6 (3.62)	0.049 (0.28)	R-21.4 (3.76)	0.047 (0.27)	R-21.8 (3.84)	0.046 (0.26)
R-27.3 (4.81)	R-30.6 (5.39)	R-25.7 (4.53)	0.041 (0.23)	R-26.9 (4.73)	0.039 (0.22)	R-27.5 (4.84)	0.038 (0.22)
R-35.7 (6.29)	R-39.0 (6.87)	R-32.6 (5.75)	0.031 (0.17)	R-34.2 (6.02)	0.029 (0.17)	R-35.0 (6.17)	0.029 (0.16)
R-42.0 (7.40)	R-45.3 (7.98)	R-37.6 (6.63)	0.027 (0.15)	R-39.6 (6.97)	0.025 (0.14)	R-40.6 (7.15)	0.025 (0.14)
R-48.3 (8.51)	R-51.6 (9.08)	R-42.7 (7.52)	0.024 (0.13)	R-45.0 (7.93)	0.023 (0.13)	R-46.3 (8.15)	0.022 (0.12)
R-54.6 (9.62)	R-57.9 (10.19)	R-47.8 (8.42)	0.021 (0.12)	R-50.4 (8.88)	0.020 (0.11)	R-51.9 (9.14)	0.019 (0.11)
R-60.9 (10.73)	R-64.2 (11.30)	R-52.9 (9.31)	0.019 (0.11)	R-55.9 (9.84)	0.018 (0.10)	R-57.5 (10.13)	0.018 (0.10)
R-67.2 (11.84)	R-70.5 (12.41)	R-58.0 (10.21)	0.017 (0.10)	R-61.3 (10.79)	0.016 (0.09)	R-63.1 (11.12)	0.016 (0.09)

Detail 5.1.106

Exterior and Interior Insulated 6" x 1 5/8" Steel Stud (24" o.c.) Wall Assembly with EJOT Crossfix Console and Vertical Rail System Supporting Metal Cladding and R-20 Batt Insulation in Stud Cavity - Clear Wall

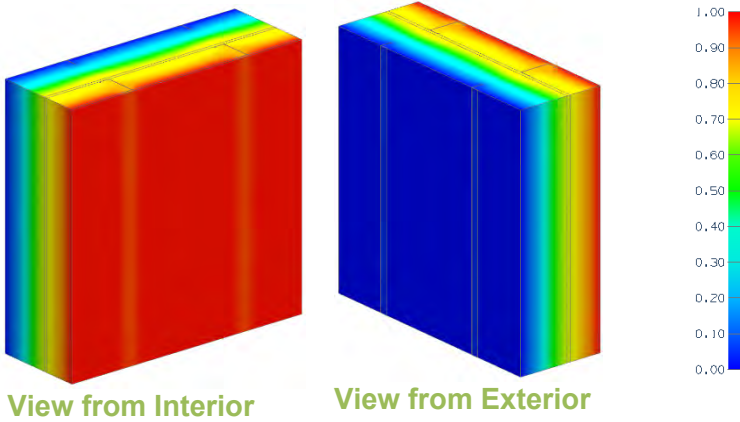

Thermal Performance Indicators

Assembly 1D (Nominal) R-Value	R_{1D}	R-22.4 (3.94 RSI) + exterior insulation
Transmittance / Resistance	U_o , R_o	"Clear wall" U- and R-value

Nominal (1D) vs. Assembly Performance Indicators

Exterior Insulation 1D R-Value (RSI)	R_{1D} ft ² ·hr·°F / Btu (m ² K / W)	24" Vertical Clip Spacing		36" Vertical Clip Spacing		48" Vertical Clip Spacing	
		R_o ft ² ·hr·°F / Btu (m ² K / W)	U_o Btu/ft ² ·hr·°F (W/m ² K)	R_o ft ² ·hr·°F / Btu (m ² K / W)	U_o Btu/ft ² ·hr·°F (W/m ² K)	R_o ft ² ·hr·°F / Btu (m ² K / W)	U_o Btu/ft ² ·hr·°F (W/m ² K)
R-8.4 (1.48)	R-30.8 (5.42)	R-20.9 (3.68)	0.048 (0.27)	R-21.3 (3.75)	0.047 (0.27)	R-21.5 (3.79)	0.046 (0.26)
R-12.6 (2.22)	R-35.0 (6.16)	R-24.0 (4.23)	0.042 (0.24)	R-24.6 (4.34)	0.041 (0.23)	R-25.0 (4.40)	0.040 (0.23)
R-14.7 (2.59)	R-37.1 (6.53)	R-25.6 (4.50)	0.039 (0.22)	R-26.3 (4.63)	0.038 (0.22)	R-26.7 (4.70)	0.037 (0.21)
R-21.0 (3.70)	R-43.4 (7.64)	R-30.9 (5.43)	0.032 (0.18)	R-32.0 (5.63)	0.031 (0.18)	R-32.6 (5.74)	0.031 (0.17)
R-27.3 (4.81)	R-49.7 (8.75)	R-36.0 (6.35)	0.028 (0.16)	R-37.5 (6.61)	0.027 (0.16)	R-38.3 (6.75)	0.027 (0.15)
R-35.7 (6.29)	R-58.1 (10.23)	R-43.0 (7.56)	0.023 (0.13)	R-44.9 (7.91)	0.022 (0.13)	R-46.0 (8.10)	0.022 (0.12)
R-42.0 (7.40)	R-64.4 (11.34)	R-48.0 (8.45)	0.021 (0.12)	R-50.3 (8.86)	0.020 (0.11)	R-51.6 (9.08)	0.019 (0.11)
R-48.3 (8.51)	R-70.7 (12.45)	R-53.1 (9.34)	0.019 (0.11)	R-55.8 (9.82)	0.018 (0.10)	R-57.2 (10.08)	0.018 (0.10)
R-54.6 (9.62)	R-77.0 (13.56)	R-58.1 (10.24)	0.017 (0.10)	R-61.2 (10.78)	0.016 (0.09)	R-62.8 (11.07)	0.016 (0.09)
R-60.9 (10.73)	R-83.3 (14.67)	R-63.2 (11.13)	0.016 (0.09)	R-66.6 (11.73)	0.015 (0.09)	R-68.5 (12.06)	0.015 (0.08)
R-67.2 (11.84)	R-89.6 (15.78)	R-68.3 (12.03)	0.015 (0.08)	R-72.1 (12.69)	0.014 (0.08)	R-74.1 (13.05)	0.013 (0.08)

Detail 5.1.107

Exterior Insulated 6" x 1/58" Steel Stud (16" o.c.) Wall Assembly with Horizontal Z-Girts (24" o.c.) Supporting Cladding and Owens Corning ThermaFiber RainBarrier HC Max Insulation – Clear Wall

Thermal Performance Indicators

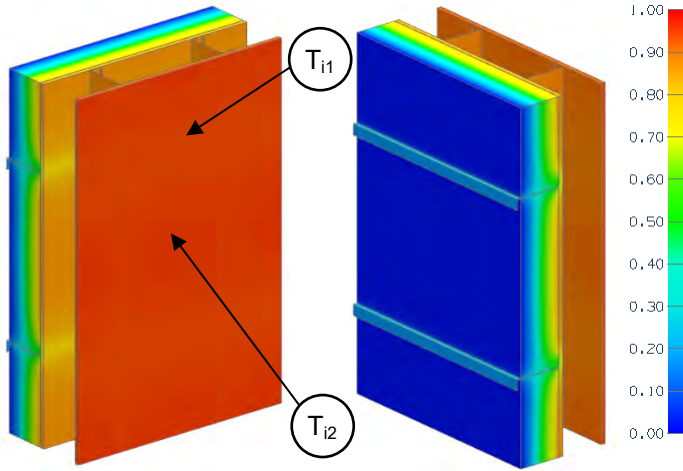

Assembly 1D (Nominal) R-Value	R_{1D}	R-3.4 (0.60 RSI) + exterior insulation
Transmittance / Resistance	U_o, R_o	"clear wall" U- and R-value
Surface Temperature Index	T_i	0 = exterior temperature 1 = interior temperature

View from Interior

View from Exterior

Nominal (1D) vs. Assembly Performance Indicators

Exterior Insulation 1D R-Value (RSI)	R_{1D} ft ² ·hr·°F / Btu (m ² K / W)	R_o ft ² ·hr·°F / Btu (m ² K / W)	U_o Btu/ft ² ·hr ·°F (W/m ² K)
R-4.0 (0.70)	R-7.4 (1.30)	R-6.5 (1.15)	0.153 (0.87)
R-8.0 (1.41)	R-11.4 (2.01)	R-8.6 (1.52)	0.116 (0.66)
R-12.0 (2.11)	R-15.4 (2.71)	R-10.7 (1.89)	0.093 (0.53)
R-16.0 (2.82)	R-19.4 (3.42)	R-12.2 (2.15)	0.082 (0.46)
R-20.0 (3.52)	R-23.4 (4.12)	R-13.7 (2.42)	0.073 (0.41)
R-24.0 (4.23)	R-27.4 (4.82)	R-15.0 (2.64)	0.067 (0.38)

Temperature Indices

	R4	R12	R20	R24	
T_{i1}	0.62	0.73	0.77	0.79	Min T on sheathing, along girts between studs
T_{i2}	0.69	0.83	0.87	0.88	Max T on sheathing, between studs and girt

Temperature indices listed for selected scenarios. All other scenarios to be interpolated.

Detail 5.1.108

Exterior Insulated 6" x 1 5/8" Steel Stud (16" o.c.) Wall Assembly with High Compression Insulation and Through Insulation Steel Fasteners (12" o.c.) Supporting Cladding, Owens Corning ThermaFiber RainBarrier HC Max Insulation – Clear Wall

Thermal Performance Indicators

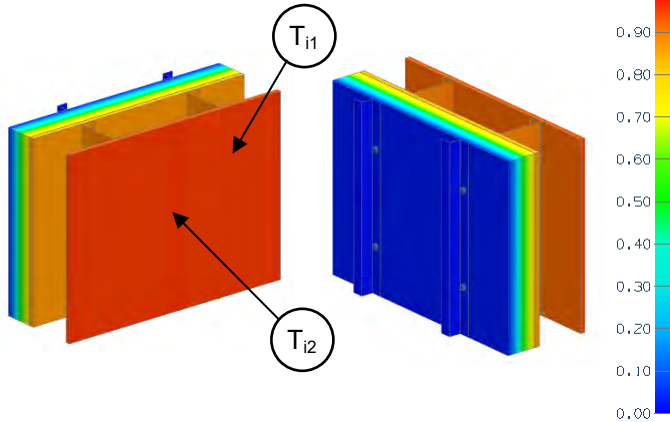

Assembly 1D (Nominal) R-Value	R_{1D}	R-3.4 (0.60 RSI) + exterior insulation
Transmittance / Resistance	U_o, R_o	"clear wall" U- and R-value
Surface Temperature Index	T_i	0 = exterior temperature 1 = interior temperature

View from Interior

View from Exterior

Nominal (1D) vs. Assembly Performance Indicators

Exterior Insulation 1D R-Value (RSI)	R_{1D} ft ² ·hr·°F / Btu (m ² K / W)	R_o ft ² ·hr·°F / Btu (m ² K / W)	U_o Btu/ft ² ·hr·°F (W/m ² K)
R-4.0 (0.70)	R-7.4 (1.30)	R-7.0 (1.24)	0.142 (0.81)
R-8.0 (1.41)	R-11.4 (2.01)	R-10.2 (1.79)	0.098 (0.56)
R-12.0 (2.11)	R-15.4 (2.71)	R-13.3 (2.35)	0.075 (0.43)
R-16.0 (2.82)	R-19.4 (3.42)	R-16.3 (2.87)	0.061 (0.35)

Temperature Indices

	R4	R12	R16	
T_{i1}	0.37	0.54	0.59	Min T on sheathing, at fastener along studs
T_{i2}	0.69	0.85	0.88	Min T on sheathing, between studs and fasteners

Temperature indices listed for selected scenarios. All other scenarios to be interpolated.

Detail 5.1.109

Exterior Insulated 6" x 1 5/8" Steel Stud (16" o.c.) Wall Assembly with High Compression Insulation and Through Insulation Steel Fasteners (12" o.c.) Supporting Cladding, Owens Corning ThermaFiber RainBarrier Ci HC 80/45 Insulation – Clear Wall

Thermal Performance Indicators

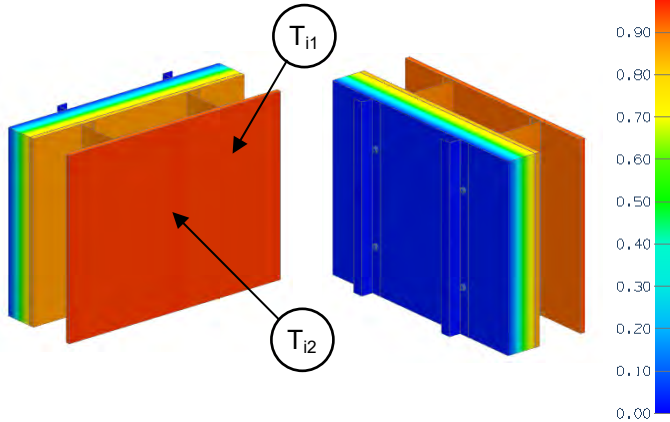

Assembly 1D (Nominal) R-Value	R_{1D}	R-3.4 (0.60 RSI) + exterior insulation
Transmittance / Resistance	U_o, R_o	"clear wall" U- and R-value
Surface Temperature Index	T_i	0 = exterior temperature 1 = interior temperature

View from Interior

View from Exterior

Nominal (1D) vs. Assembly Performance Indicators

Exterior Insulation 1D R-Value (RSI)	R_{1D} ft ² ·hr·°F / Btu (m ² K / W)	R_o ft ² ·hr·°F / Btu (m ² K / W)	U_o Btu/ft ² ·hr ·°F (W/m ² K)
R-4.2 (0.74)	R-7.6 (1.34)	R-7.2 (1.27)	0.139 (0.79)
R-8.4 (1.48)	R-11.8 (2.08)	R-10.5 (1.85)	0.095 (0.54)
R-12.6 (2.22)	R-16.0 (2.82)	R-13.8 (2.42)	0.073 (0.41)
R-16.8 (2.96)	R-20.2 (3.56)	R-16.8 (2.96)	0.059 (0.34)

Temperature Indices

	R4	R12	R16	
T_{i1}	0.38	0.54	0.59	Min T on sheathing, at fastener along studs
T_{i2}	0.70	0.85	0.88	Min T on sheathing, between studs and fasteners

Temperature indices listed for selected scenarios. All other scenarios to be interpolated.

Detail 5.1.110

Exterior Insulated 6" x 1 5/8" Steel Stud (16" o.c.) Wall Assembly with High Compression Insulation and Through Insulation Stainless Steel Fasteners (12" o.c.) Supporting Cladding, Owens Corning ThermaFiber RainBarrier HC Max Insulation – Clear Wall

Thermal Performance Indicators

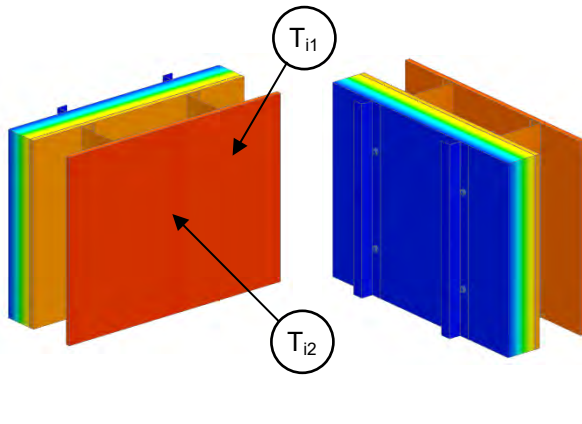

Assembly 1D (Nominal) R-Value	R_{1D}	R-3.4 (0.60 RSI) + exterior insulation
Transmittance / Resistance	U_o, R_o	"clear wall" U- and R-value
Surface Temperature Index	T_i	0 = exterior temperature 1 = interior temperature

View from Interior View from Exterior

Nominal (1D) vs. Assembly Performance Indicators

Exterior Insulation 1D R-Value (RSI)	R_{1D} ft ² ·hr·°F / Btu (m ² K / W)	R_o ft ² ·hr·°F / Btu (m ² K / W)	U_o Btu/ft ² ·hr·°F (W/m ² K)
R-4.0 (0.70)	R-7.4 (1.30)	R-7.2 (1.27)	0.139 (0.79)
R-8.0 (1.41)	R-11.4 (2.01)	R-10.7 (1.89)	0.093 (0.53)
R-12.0 (2.11)	R-15.4 (2.71)	R-14.3 (2.52)	0.070 (0.40)
R-16.0 (2.82)	R-19.4 (3.42)	R-17.8 (3.14)	0.056 (0.32)

Temperature Indices

	R4	R12	R16	
T_{i1}	0.51	0.71	0.76	Min T on sheathing, at fastener along studs
T_{i2}	0.70	0.85	0.88	Min T on sheathing, between studs and fasteners

Temperature indices listed for selected scenarios. All other scenarios to be interpolated.

Detail 5.1.111

Exterior Insulated 6" x 1 5/8" Steel Stud (16" o.c.) Wall Assembly with High Compression Insulation and Through Insulation Stainless Steel Fasteners (12" o.c.) Supporting Cladding, Owens Corning ThermaFiber RainBarrier Ci HC 80/45 Insulation – Clear Wall

Thermal Performance Indicators

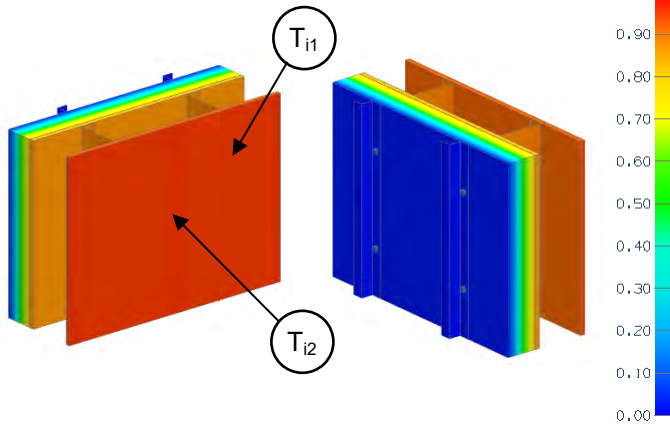

Assembly 1D (Nominal) R-Value	R_{1D}	R-3.4 (0.60 RSI) + exterior insulation
Transmittance / Resistance	U_o, R_o	"clear wall" U- and R-value
Surface Temperature Index	T_i	0 = exterior temperature 1 = interior temperature

View from Interior

View from Exterior

Nominal (1D) vs. Assembly Performance Indicators

Exterior Insulation 1D R-Value (RSI)	R_{1D} ft ² ·hr·°F / Btu (m ² K / W)	R_o ft ² ·hr·°F / Btu (m ² K / W)	U_o Btu/ft ² ·hr·°F (W/m ² K)
R-4.2 (0.74)	R-7.6 (1.34)	R-7.4 (1.30)	0.136 (0.77)
R-8.4 (1.48)	R-11.8 (2.08)	R-11.1 (1.95)	0.090 (0.51)
R-12.6 (2.22)	R-16.0 (2.82)	R-14.8 (2.61)	0.068 (0.38)
R-16.8 (2.96)	R-20.2 (3.56)	R-18.5 (3.26)	0.054 (0.31)

Temperature Indices

	R4	R12	R16	
T_{i1}	0.51	0.72	0.76	Min T on sheathing, at fastener along studs
T_{i2}	0.70	0.86	0.89	Min T on sheathing, between studs and fasteners

Temperature indices listed for selected scenarios. All other scenarios to be interpolated.

Detail 5.1.112

Exterior and Interior Insulated 6" x 1 5/8" Steel Stud (16" o.c.) Wall Assembly with High Compression Insulation and Through Insulation Stainless Steel Fasteners (16" o.c.) Supporting Cladding, Owens Corning ThermaFiber RainBarrier HC Max Insulation and R-20 Batt Insulation in Stud Cavity – Clear Wall

Thermal Performance Indicators

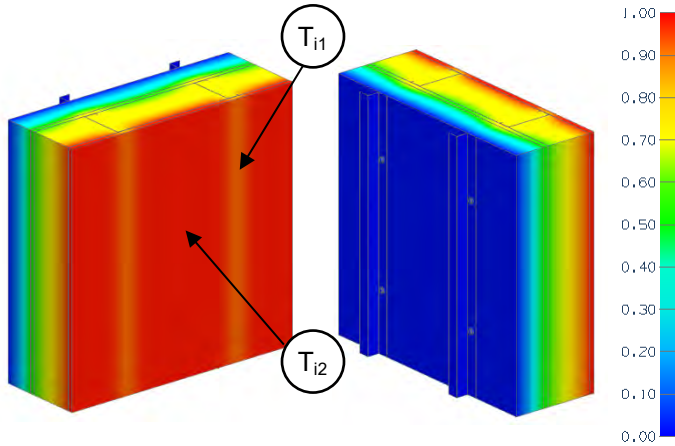

Assembly 1D (Nominal) R-Value	R_{1D}	R-22.5 (3.96 RSI) + exterior insulation
Transmittance / Resistance	U_o, R_o	"clear wall" U- and R-value
Surface Temperature Index	T_i	0 = exterior temperature 1 = interior temperature

View from Interior View from Exterior

Nominal (1D) vs. Assembly Performance Indicators

Exterior Insulation 1D R-Value (RSI)	R_{1D} ft ² ·hr·°F / Btu (m ² K / W)	R_o ft ² ·hr·°F / Btu (m ² K / W)	U_o Btu/ft ² ·hr ·°F (W/m ² K)
R-4.0 (0.70)	R-26.5 (4.67)	R-16.0 (2.82)	0.062 (0.35)
R-8.0 (1.41)	R-30.5 (5.37)	R-19.7 (3.48)	0.051 (0.29)
R-12.0 (2.11)	R-34.5 (6.08)	R-23.4 (4.13)	0.043 (0.24)
R-16.0 (2.82)	R-38.5 (6.78)	R-27.1 (4.77)	0.037 (0.21)

Temperature Indices

	R4.2	R12.6	R16.8	
T_{i1}	0.39	0.56	0.62	Min T on sheathing, at fastener along studs
T_{i2}	0.23	0.46	0.53	Min T on sheathing, between studs and fasteners

Temperature indices listed for selected scenarios. All other scenarios to be interpolated.

Detail 5.1.113

Exterior and Interior Insulated 6" x 1 5/8" Steel Stud (16" o.c.) Wall Assembly with High Compression Insulation and Through Insulation Stainless Steel Fasteners (16" o.c.) Supporting Cladding, Owens Corning ThermaFiber RainBarrier Ci HC 80/45 Insulation and R-20 Batt Insulation in Stud Cavity – Clear Wall

Thermal Performance Indicators

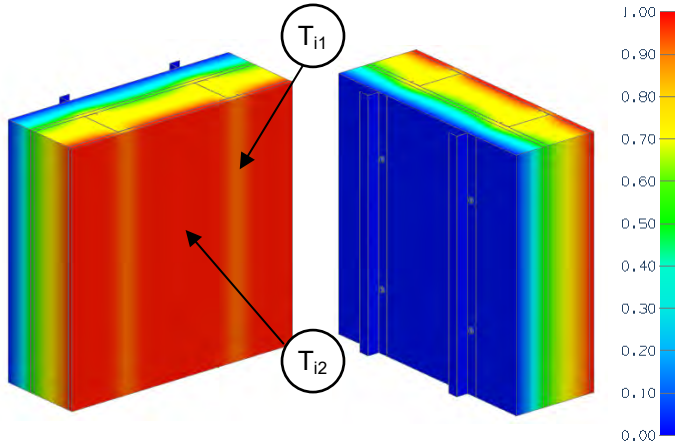

Assembly 1D (Nominal) R-Value	R_{1D}	R-22.5 (3.96 RSI) + exterior insulation
Transmittance / Resistance	U_o, R_o	"clear wall" U- and R-value
Surface Temperature Index	T_i	0 = exterior temperature 1 = interior temperature

View from Interior

View from Exterior

Nominal (1D) vs. Assembly Performance Indicators

Exterior Insulation 1D R-Value (RSI)	R_{1D} ft ² ·hr·°F / Btu (m ² K / W)	R_o ft ² ·hr·°F / Btu (m ² K / W)	U_o Btu/ft ² ·hr ·°F (W/m ² K)
R-4.2 (0.74)	R-26.7 (4.70)	R-16.2 (2.85)	0.062 (0.35)
R-8.4 (1.48)	R-30.9 (5.44)	R-20.1 (3.54)	0.050 (0.28)
R-12.6 (2.22)	R-35.1 (6.18)	R-24.0 (4.22)	0.042 (0.24)
R-16.8 (2.96)	R-39.3 (6.92)	R-27.8 (4.89)	0.036 (0.20)

Temperature Indices

	R4.2	R12.6	R16.8	
T_{i1}	0.39	0.57	0.62	Min T on sheathing, at fastener along studs
T_{i2}	0.24	0.47	0.54	Min T on sheathing, between studs and fasteners

Temperature indices listed for selected scenarios. All other scenarios to be interpolated.

Detail 5.1.114

Exterior and Interior Insulated Wall Assembly with Brick Ties Supporting Brick Veneer and R-12 Batt Insulation in Stud Cavity – Clear Wall

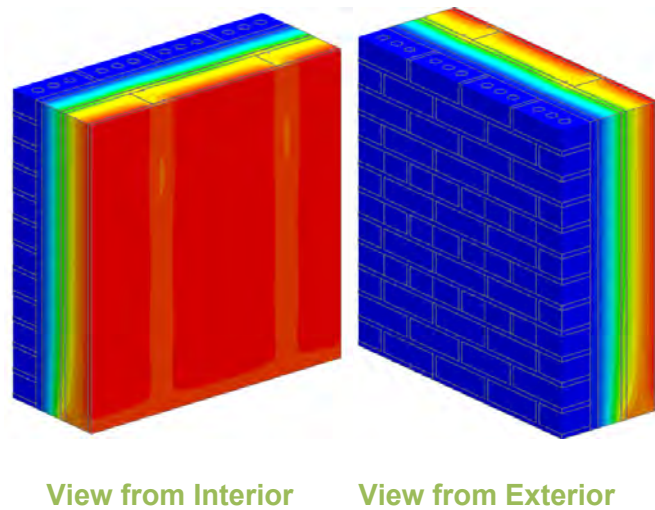

Thermal Performance Indicators

Assembly 1D (Nominal) R-Value	R_{1D}	R-15.3 (2.70 RSI) + exterior insulation
Transmittance / Resistance without Anomaly	U_o, R_o	“clear wall” U- and R-value without slab and shelf angle

Nominal (1D) vs. Assembly Performance Indicators

Exterior Insulation 1D R-Value (RSI)	R_{1D} ft ² ·hr·°F / Btu (m ² K / W)	R_o ft ² ·hr·°F / Btu (m ² K / W)	U_o Btu/ft ² ·hr·°F (W/m ² K)
R-5 (0.88)	R-20.3 (3.58)	R-13.9 (2.45)	0.072 (0.41)
R-10 (1.76)	R-25.3 (4.46)	R-17.0 (3.00)	0.059 (0.33)
R-15 (2.64)	R-30.3 (5.34)	R-19.8 (3.48)	0.051 (0.29)
R-20 (3.52)	R-35.3 (6.22)	R-22.5 (3.96)	0.045 (0.25)
R-25 (4.40)	R-40.3 (7.10)	R-24.9 (4.39)	0.040 (0.23)

Detail 5.1.115

Exterior Insulated 6" x 1 5/8" Steel Stud (16" o.c.) Wall Assembly with SOPREMA SOPRA-XPS 20 and ACS-S Thermal Clip Supporting Metal Cladding - Clear Wall

Thermal Performance Indicators

Assembly 1D (Nominal) R-Value	R_{1D}	R-3.17 (0.56 RSI) + exterior insulation
Transmittance / Resistance	U_o , R_o	"Clear wall" U- and R-value

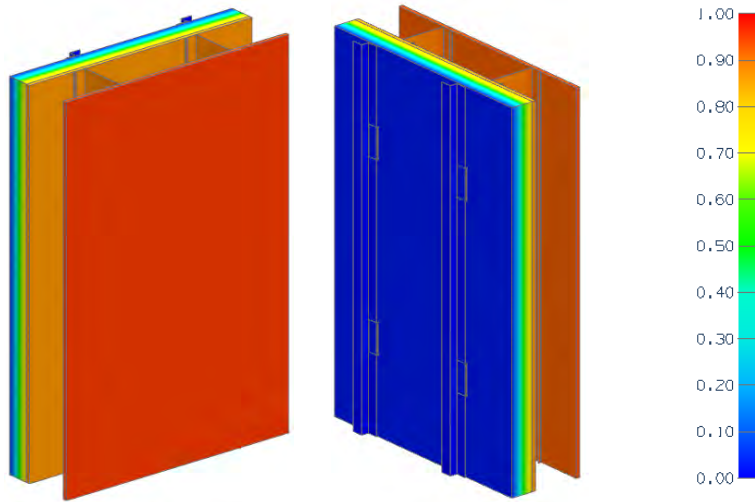

View from Interior View from Exterior

Nominal (1D) vs. Assembly Performance Indicators

Exterior Insulation 1D R-value (RSI)	R_{1D} ft ² ·hr·°F / Btu (m ² K / W)	24" Vertical Spacing		36" Vertical Spacing		48" Vertical Spacing	
		R_o ft ² ·hr·°F / Btu (m ² K / W)	U_o Btu/ft ² ·hr·°F (W/m ² K)	R_o ft ² ·hr·°F / Btu (m ² K / W)	U_o Btu/ft ² ·hr·°F (W/m ² K)	R_o ft ² ·hr·°F / Btu (m ² K / W)	U_o Btu/ft ² ·hr·°F (W/m ² K)
R-15.0 (2.64)	R-18.2 (3.20)	R-17.2 (3.03)	0.058 (0.33)	R-17.5 (3.09)	0.057 (0.32)	R-17.7 (3.11)	0.057 (0.32)
R-20.0 (3.52)	R-23.2 (4.08)	R-21.6 (3.81)	0.046 (0.26)	R-22.1 (3.89)	0.045 (0.26)	R-22.4 (3.94)	0.045 (0.25)
R-25.0 (4.40)	R-28.2 (4.96)	R-25.9 (4.56)	0.039 (0.22)	R-26.6 (4.68)	0.038 (0.21)	R-27.0 (4.75)	0.037 (0.21)
R-30.0 (5.28)	R-33.2 (5.84)	R-30.2 (5.32)	0.033 (0.19)	R-31.1 (5.48)	0.032 (0.18)	R-31.6 (5.57)	0.032 (0.18)
R-35.0 (6.16)	R-38.2 (6.72)	R-34.3 (6.04)	0.029 (0.17)	R-35.5 (6.25)	0.028 (0.16)	R-36.1 (6.36)	0.028 (0.16)

Detail 5.1.116

Exterior Insulated 6" x 1 5/8" Steel Stud (24" o.c.) Wall Assembly with SOPREMA SOPRA-XPS 20 and ACS-S Thermal Clip Supporting Metal Cladding - Clear Wall

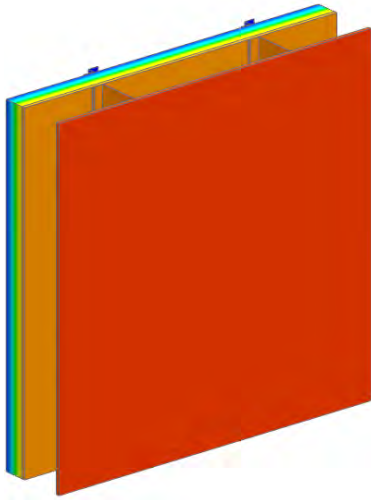

View from Interior

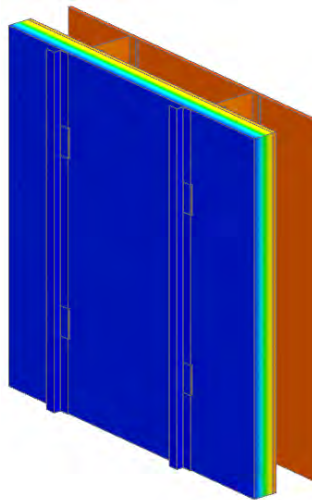

View from Exterior



Thermal Performance Indicators

Assembly 1D (Nominal) R-Value	R_{1D}	R-3.17 (0.56 RSI) + exterior insulation
Transmittance / Resistance	U_o , R_o	"Clear wall" U- and R-value

Nominal (1D) vs. Assembly Performance Indicators

Exterior Insulation 1D R-value (RSI)	R_{1D} ft ² ·hr·°F / Btu (m ² K / W)	24" Vertical Spacing		36" Vertical Spacing		48" Vertical Spacing	
		R_o ft ² ·hr·°F / Btu (m ² K / W)	U_o Btu/ft ² ·hr·°F (W/m ² K)	R_o ft ² ·hr·°F / Btu (m ² K / W)	U_o Btu/ft ² ·hr·°F (W/m ² K)	R_o ft ² ·hr·°F / Btu (m ² K / W)	U_o Btu/ft ² ·hr·°F (W/m ² K)
R-15.0 (2.64)	R-18.2 (3.20)	R-17.5 (3.09)	0.057 (0.32)	R-17.7 (3.12)	0.056 (0.32)	R-17.8 (3.14)	0.056 (0.32)
R-20.0 (3.52)	R-23.2 (4.08)	R-22.1 (3.90)	0.045 (0.26)	R-22.5 (3.96)	0.045 (0.25)	R-22.6 (3.99)	0.044 (0.25)
R-25.0 (4.40)	R-28.2 (4.96)	R-26.6 (4.69)	0.038 (0.21)	R-27.1 (4.78)	0.037 (0.21)	R-27.4 (4.82)	0.037 (0.21)
R-30.0 (5.28)	R-33.2 (5.84)	R-31.1 (5.48)	0.032 (0.18)	R-31.8 (5.60)	0.031 (0.18)	R-32.1 (5.65)	0.031 (0.18)
R-35.0 (6.16)	R-38.2 (6.72)	R-35.5 (6.26)	0.028 (0.16)	R-36.3 (6.40)	0.028 (0.16)	R-36.8 (6.48)	0.027 (0.15)

Detail 5.1.117

Exterior Insulated 6" x 1 5/8" Steel Stud (16" o.c.) Wall Assembly with SOPREMA SOPRA-SPF 202 and ACS-S Thermal Clip Supporting Metal Cladding - Clear Wall

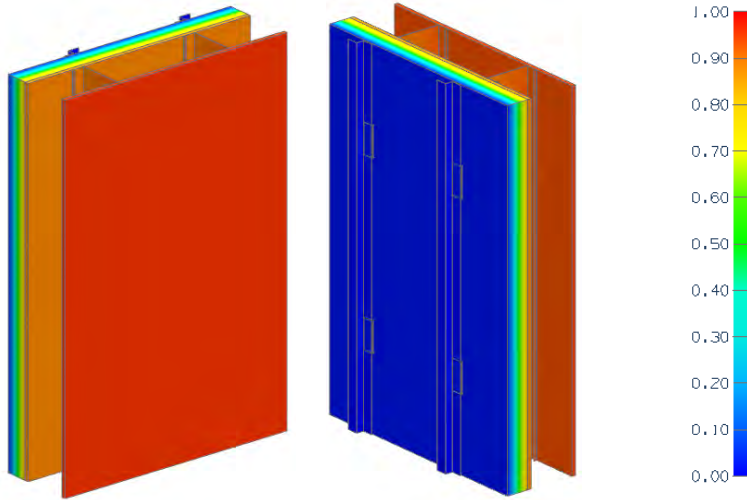

View from Interior View from Exterior

Thermal Performance Indicators

Assembly 1D (Nominal) R-Value	R_{1D}	R-3.17 (0.56 RSI) + exterior insulation
Transmittance / Resistance	U_o , R_o	"Clear wall" U- and R-value

Nominal (1D) vs. Assembly Performance Indicators

Exterior Insulation 1D R-value (RSI)	R_{1D} ft ² ·hr·°F / Btu (m ² K / W)	24" Vertical Spacing		36" Vertical Spacing		48" Vertical Spacing	
		R_o ft ² ·hr·°F / Btu (m ² K / W)	U_o Btu/ft ² ·hr ·°F (W/m ² K)	R_o ft ² ·hr·°F / Btu (m ² K / W)	U_o Btu/ft ² ·hr ·°F (W/m ² K)	R_o ft ² ·hr·°F / Btu (m ² K / W)	U_o Btu/ft ² ·hr ·°F (W/m ² K)
R-6.2 (1.09)	R-9.4 (1.65)	R-9.2 (1.62)	0.109 (0.62)	R-9.2 (1.63)	0.108 (0.61)	R-9.2 (1.63)	0.108 (0.61)
R-12.4 (2.18)	R-15.6 (2.74)	R-14.8 (2.61)*	0.067 (0.38)*	R-15.0 (2.65)*	0.066 (0.38)*	R-15.2 (2.67)*	0.066 (0.37)*
R-18.6 (3.28)	R-21.8 (3.83)	R-20.3 (3.58)	0.049 (0.28)	R-20.8 (3.66)	0.048 (0.27)	R-21.0 (3.70)	0.048 (0.27)
R-24.8 (4.37)	R-28.0 (4.93)	R-25.7 (4.52)	0.039 (0.22)	R-26.4 (4.64)	0.038 (0.22)	R-26.7 (4.71)	0.037 (0.21)
R-31.0 (5.46)	R-34.2 (6.02)	R-30.8 (5.42)	0.033 (0.18)	R-31.8 (5.60)	0.031 (0.18)	R-32.3 (5.70)	0.031 (0.18)
R-37.2 (6.55)	R-40.4 (7.11)	R-36.0 (6.33)	0.028 (0.16)	R-37.3 (6.57)	0.027 (0.15)	R-38.0 (6.69)	0.026 (0.15)

*Indicates interpolated value

Detail 5.1.118

Exterior Insulated 6" x 1 5/8" Steel Stud (24" o.c.) Wall Assembly with SOPREMA SOPRA-SPF 202 and ACS-S Thermal Clip Supporting Metal Cladding - Clear Wall

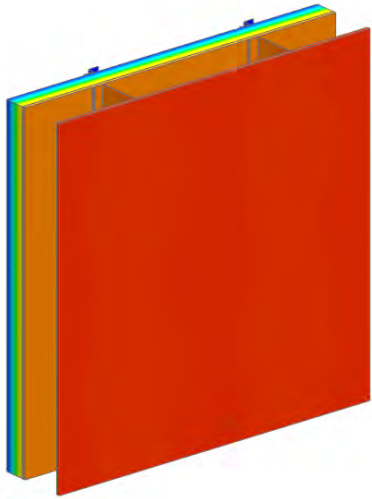

View from Interior

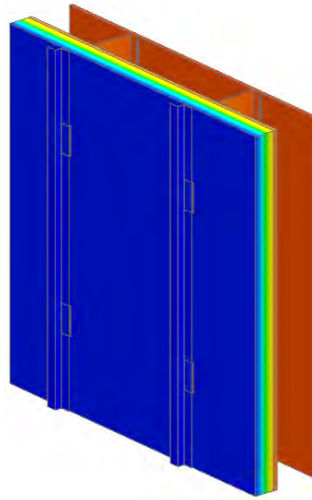

View from Exterior



Thermal Performance Indicators

Assembly 1D (Nominal) R-Value	R_{1D}	R-3.17 (0.56 RSI) + exterior insulation
Transmittance / Resistance	U_o , R_o	"Clear wall" U- and R-value

Nominal (1D) vs. Assembly Performance Indicators

Exterior Insulation 1D R-value (RSI)	R_{1D} ft ² ·hr·°F / Btu (m ² K / W)	24" Vertical Spacing		36" Vertical Spacing		48" Vertical Spacing	
		R_o ft ² ·hr·°F / Btu (m ² K / W)	U_o Btu/ft ² ·hr ·°F (W/m ² K)	R_o ft ² ·hr·°F / Btu (m ² K / W)	U_o Btu/ft ² ·hr ·°F (W/m ² K)	R_o ft ² ·hr·°F / Btu (m ² K / W)	U_o Btu/ft ² ·hr ·°F (W/m ² K)
R-6.2 (1.09)	R-9.4 (1.65)	R-9.3 (1.63)	0.108 (0.61)	R-9.3 (1.63)	0.108 (0.61)	R-9.3 (1.64)	0.108 (0.61)
R-12.4 (2.18)	R-15.6 (2.74)	R-15.1 (2.65)*	0.066 (0.38)*	R-15.2 (2.68)*	0.066 (0.37)*	R-15.3 (2.69)*	0.065 (0.37)*
R-18.6 (3.28)	R-21.8 (3.83)	R-20.8 (3.66)	0.048 (0.27)	R-21.1 (3.71)	0.047 (0.27)	R-21.2 (3.74)	0.047 (0.27)
R-24.8 (4.37)	R-28.0 (4.93)	R-26.4 (4.65)	0.038 (0.22)	R-26.9 (4.73)	0.037 (0.21)	R-27.1 (4.78)	0.037 (0.21)
R-31.0 (5.46)	R-34.2 (6.02)	R-31.8 (5.60)	0.031 (0.18)	R-32.6 (5.73)	0.031 (0.17)	R-32.9 (5.80)	0.030 (0.17)
R-37.2 (6.55)	R-40.4 (7.11)	R-37.3 (6.57)	0.027 (0.15)	R-38.2 (6.73)	0.026 (0.15)	R-38.7 (6.82)	0.026 (0.15)

*Indicates interpolated value

Detail 5.1.119

Exterior Insulated 6" x 1 5/8" Steel Stud (16" o.c.) Wall Assembly with SOPREMA SOPRA-ISO V ALU and ACS-S Thermal Clip Supporting Metal Cladding - Clear Wall

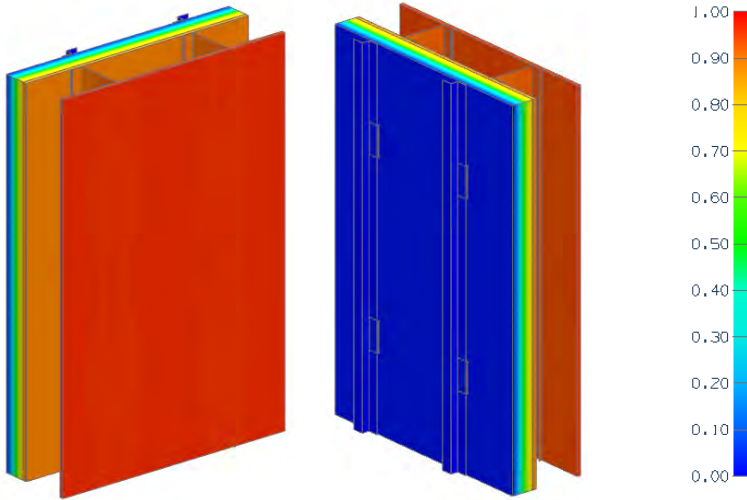

View from Interior View from Exterior

Thermal Performance Indicators

Assembly 1D (Nominal) R-Value	R_{1D}	R-3.17 (0.56 RSI) + exterior insulation
Transmittance / Resistance	U_o , R_o	"Clear wall" U- and R-value

Nominal (1D) vs. Assembly Performance Indicators

Exterior Insulation 1D R-value (RSI)	R_{1D} ft ² ·hr·°F / Btu (m ² K / W)	24" Vertical Spacing		36" Vertical Spacing		48" Vertical Spacing	
		R_o ft ² ·hr·°F / Btu (m ² K / W)	U_o Btu/ft ² ·hr ·°F (W/m ² K)	R_o ft ² ·hr·°F / Btu (m ² K / W)	U_o Btu/ft ² ·hr ·°F (W/m ² K)	R_o ft ² ·hr·°F / Btu (m ² K / W)	U_o Btu/ft ² ·hr ·°F (W/m ² K)
R-6.5 (1.14)	R-9.7 (1.70)	R-9.5 (1.68)	0.105 (0.60)	R-9.6 (1.69)	0.104 (0.59)	R-9.6 (1.69)	0.104 (0.59)
R-13.0 (2.29)	R-16.2 (2.85)	R-15.4 (2.71)*	0.065 (0.37)*	R-15.7 (2.76)*	0.064 (0.36)*	R-15.8 (2.78)*	0.063 (0.36)*
R-16.3 (2.86)	R-19.4 (3.42)	R-18.3 (3.22)*	0.055 (0.31)*	R-18.6 (3.28)*	0.054 (0.30)*	R-18.8 (3.32)*	0.053 (0.30)*
R-19.5 (3.43)	R-22.7 (3.99)	R-21.2 (3.73)	0.047 (0.27)	R-21.6 (3.81)	0.046 (0.26)	R-21.9 (3.85)	0.046 (0.26)
R-22.8 (4.01)	R-25.9 (4.56)	R-23.9 (4.22)*	0.042 (0.24)*	R-24.6 (4.33)*	0.041 (0.23)*	R-24.9 (4.38)*	0.040 (0.23)*
R-26.0 (4.58)	R-29.2 (5.14)	R-26.7 (4.71)	0.037 (0.21)	R-27.5 (4.84)	0.036 (0.21)	R-27.9 (4.91)	0.036 (0.20)
R-29.3 (5.15)	R-32.4 (5.71)	R-29.5 (5.19)*	0.034 (0.19)*	R-30.4 (5.35)*	0.033 (0.19)*	R-30.9 (5.43)*	0.032 (0.18)*
R-32.5 (5.72)	R-35.7 (6.28)	R-32.1 (5.65)	0.031 (0.18)	R-33.2 (5.84)	0.030 (0.17)	R-33.8 (5.95)	0.030 (0.17)
R-35.8 (6.30)	R-38.9 (6.85)	R-34.8 (6.13)*	0.029 (0.16)*	R-36.1 (6.35)*	0.028 (0.16)*	R-36.7 (6.47)*	0.027 (0.15)*
R-39.0 (6.87)	R-42.2 (7.43)	R-37.5 (6.60)	0.027 (0.15)	R-38.9 (6.86)	0.026 (0.15)	R-39.7 (6.99)	0.025 (0.14)

*Indicates interpolated value

Detail 5.1.120

Exterior Insulated 6" x 1 5/8" Steel Stud (24" o.c.) Wall Assembly with SOPREMA SOPRA-ISO V ALU and ACS-S Thermal Clip Supporting Metal Cladding - Clear Wall

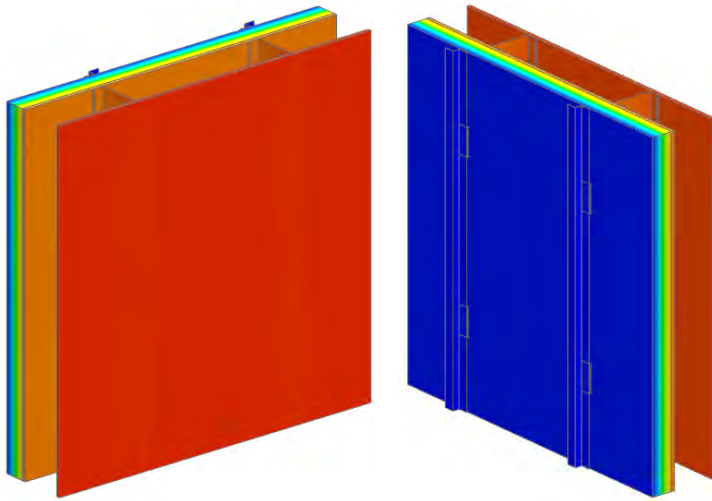

View from Interior

View from Exterior

Thermal Performance Indicators

Assembly 1D (Nominal) R-Value	R_{1D}	R-3.17 (0.56 RSI) + exterior insulation
Transmittance / Resistance	U_o , R_o	"Clear wall" U- and R-value

Nominal (1D) vs. Assembly Performance Indicators

Exterior Insulation 1D R-value (RSI)	R_{1D} ft ² ·hr·°F / Btu (m ² K / W)	24" Vertical Spacing		36" Vertical Spacing		48" Vertical Spacing	
		R_o ft ² ·hr·°F / Btu (m ² K / W)	U_o Btu/ft ² ·hr ·°F (W/m ² K)	R_o ft ² ·hr·°F / Btu (m ² K / W)	U_o Btu/ft ² ·hr ·°F (W/m ² K)	R_o ft ² ·hr·°F / Btu (m ² K / W)	U_o Btu/ft ² ·hr ·°F (W/m ² K)
R-6.5 (1.14)	R-9.7 (1.70)	R-9.6 (1.69)	0.104 (0.59)	R-9.6 (1.69)	0.104 (0.59)	R-9.6 (1.70)	0.104 (0.59)
R-13.0 (2.29)	R-16.2 (2.85)	R-15.7 (2.76)*	0.064 (0.36)*	R-15.8 (2.79)*	0.063 (0.36)*	R-15.9 (2.80)*	0.063 (0.36)*
R-16.3 (2.86)	R-19.4 (3.42)	R-18.7 (3.29)*	0.054 (0.30)*	R-18.9 (3.33)*	0.053 (0.30)*	R-19.0 (3.35)*	0.053 (0.30)*
R-19.5 (3.43)	R-22.7 (3.99)	R-21.7 (3.81)	0.046 (0.26)	R-22.0 (3.87)	0.045 (0.26)	R-22.1 (3.90)	0.045 (0.26)
R-22.8 (4.01)	R-25.9 (4.56)	R-24.6 (4.33)*	0.041 (0.23)*	R-25.0 (4.41)*	0.040 (0.23)*	R-25.2 (4.44)*	0.040 (0.23)*
R-26.0 (4.58)	R-29.2 (5.14)	R-27.5 (4.85)	0.036 (0.21)	R-28.0 (4.94)	0.036 (0.20)	R-28.3 (4.99)	0.035 (0.20)
R-29.3 (5.15)	R-32.4 (5.71)	R-30.4 (5.35)*	0.033 (0.19)*	R-31.0 (5.47)*	0.032 (0.18)*	R-31.4 (5.52)*	0.032 (0.18)*
R-32.5 (5.72)	R-35.7 (6.28)	R-33.2 (5.85)	0.030 (0.17)	R-34.0 (5.99)	0.029 (0.17)	R-34.4 (6.06)	0.029 (0.17)
R-35.8 (6.30)	R-38.9 (6.85)	R-36.1 (6.36)*	0.028 (0.16)*	R-37.0 (6.51)*	0.027 (0.15)*	R-37.4 (6.59)*	0.027 (0.15)*
R-39.0 (6.87)	R-42.2 (7.43)	R-38.9 (6.86)	0.026 (0.15)	R-39.9 (7.03)	0.025 (0.14)	R-40.5 (7.13)	0.025 (0.14)

*Indicates interpolated value

Detail 5.1.121

Exterior Insulated 6" x 1 5/8" Steel Stud (16" o.c.) Wall Assembly with Mineral Wool and ACS-S Thermal Clip Supporting Metal Cladding - Clear Wall

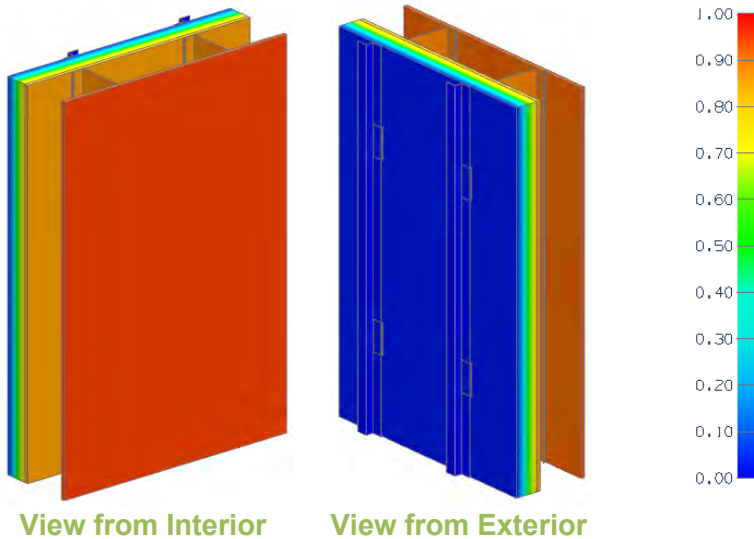

Thermal Performance Indicators

Assembly 1D (Nominal) R-Value	R_{1D}	R-3.17 (0.56 RSI) + exterior insulation
Transmittance / Resistance	U_o , R_o	"Clear wall" U- and R-value

Nominal (1D) vs. Assembly Performance Indicators

Exterior Insulation 1D R-value (RSI)	R_{1D} ft ² ·hr·°F / Btu (m ² K / W)	24" Vertical Spacing		36" Vertical Spacing		48" Vertical Spacing	
		R_o ft ² ·hr·°F / Btu (m ² K / W)	U_o Btu/ft ² ·hr ·°F (W/m ² K)	R_o ft ² ·hr·°F / Btu (m ² K / W)	U_o Btu/ft ² ·hr ·°F (W/m ² K)	R_o ft ² ·hr·°F / Btu (m ² K / W)	U_o Btu/ft ² ·hr ·°F (W/m ² K)
R-12.9 (2.27)	R-16.1 (2.83)	R-15.3 (2.70)	0.065 (0.37)	R-15.6 (2.74)	0.064 (0.36)	R-15.7 (2.76)	0.064 (0.36)
R-17.2 (3.03)	R-20.4 (3.59)	R-19.1 (3.37)*	0.052 (0.30)*	R-19.5 (3.44)*	0.051 (0.29)*	R-19.7 (3.47)*	0.051 (0.29)*
R-21.5 (3.79)	R-24.7 (4.34)	R-22.9 (4.03)	0.044 (0.25)	R-23.5 (4.13)	0.043 (0.24)	R-23.7 (4.18)	0.042 (0.24)
R-25.8 (4.54)	R-29.0 (5.10)	R-26.7 (4.70)	0.037 (0.21)	R-27.4 (4.82)	0.037 (0.21)	R-27.8 (4.89)	0.036 (0.20)
R-30.1 (5.30)	R-33.3 (5.86)	R-30.3 (5.34)	0.033 (0.19)	R-31.2 (5.50)	0.032 (0.18)	R-31.7 (5.58)	0.032 (0.18)
R-34.4 (6.06)	R-37.6 (6.62)	R-34.1 (6.00)	0.029 (0.17)	R-35.1 (6.19)	0.028 (0.16)	R-35.7 (6.29)	0.028 (0.16)

*Indicates interpolated value

Detail 5.1.122

Exterior Insulated 6" x 1 5/8" Steel Stud (24" o.c.) Wall Assembly with Mineral Wool and ACS-S Thermal Clip Supporting Metal Cladding - Clear Wall

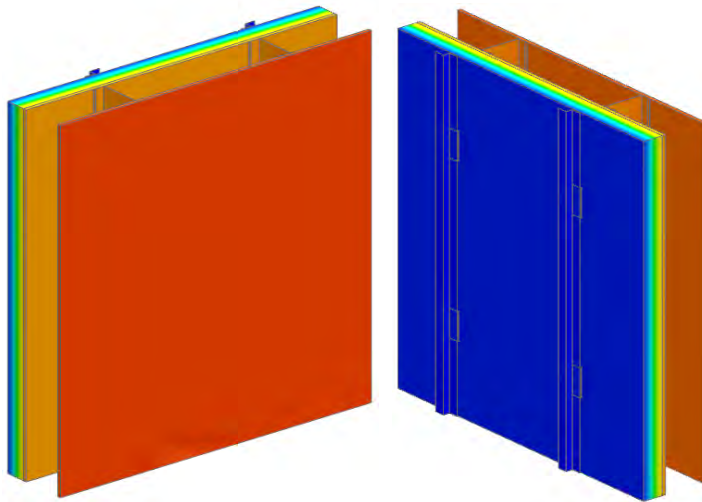

View from Interior

View from Exterior

Thermal Performance Indicators

Assembly 1D (Nominal) R-Value	R_{1D}	R-3.17 (0.56 RSI) + exterior insulation
Transmittance / Resistance	U_o , R_o	"Clear wall" U- and R-value

Nominal (1D) vs. Assembly Performance Indicators

Exterior Insulation 1D R-value (RSI)	R_{1D} ft ² ·hr·°F / Btu (m ² K / W)	24" Vertical Spacing		36" Vertical Spacing		48" Vertical Spacing	
		R_o ft ² ·hr·°F / Btu (m ² K / W)	U_o Btu/ft ² ·hr ·°F (W/m ² K)	R_o ft ² ·hr·°F / Btu (m ² K / W)	U_o Btu/ft ² ·hr ·°F (W/m ² K)	R_o ft ² ·hr·°F / Btu (m ² K / W)	U_o Btu/ft ² ·hr ·°F (W/m ² K)
R-12.9 (2.27)	R-16.1 (2.83)	R-15.6 (2.75)	0.064 (0.36)	R-15.7 (2.77)	0.063 (0.36)	R-15.8 (2.79)	0.063 (0.36)
R-17.2 (3.03)	R-20.4 (3.59)	R-19.5 (3.44)*	0.051 (0.29)*	R-19.8 (3.49)*	0.050 (0.29)*	R-19.9 (3.51)*	0.050 (0.28)*
R-21.5 (3.79)	R-24.7 (4.34)	R-23.5 (4.13)	0.043 (0.24)	R-23.9 (4.21)	0.042 (0.24)	R-24.1 (4.24)	0.042 (0.24)
R-25.8 (4.54)	R-29.0 (5.10)	R-27.4 (4.83)	0.036 (0.21)	R-27.9 (4.91)	0.036 (0.20)	R-28.2 (4.96)	0.036 (0.20)
R-30.1 (5.30)	R-33.3 (5.86)	R-31.2 (5.50)	0.032 (0.18)	R-31.9 (5.61)	0.031 (0.18)	R-32.2 (5.67)	0.031 (0.18)
R-34.4 (6.06)	R-37.6 (6.62)	R-35.2 (6.19)	0.028 (0.16)	R-35.9 (6.33)	0.028 (0.16)	R-36.3 (6.40)	0.028 (0.16)

*Indicates interpolated value

Detail 5.1.123

Exterior and Interior Insulated 6" x 1 5/8" Steel Stud (16" o.c.) Wall Assembly with SOPREMA SOPRA-XPS 20 and ACS-S Thermal Clip Supporting Metal Cladding with R-20 Cellulose Insulation in Stud Cavity - Clear Wall

Thermal Performance Indicators

Assembly 1D (Nominal) R-Value	R_{1D}	R-22.3 (3.92 RSI) + exterior insulation
Transmittance / Resistance	U_o , R_o	"Clear wall" U- and R-value

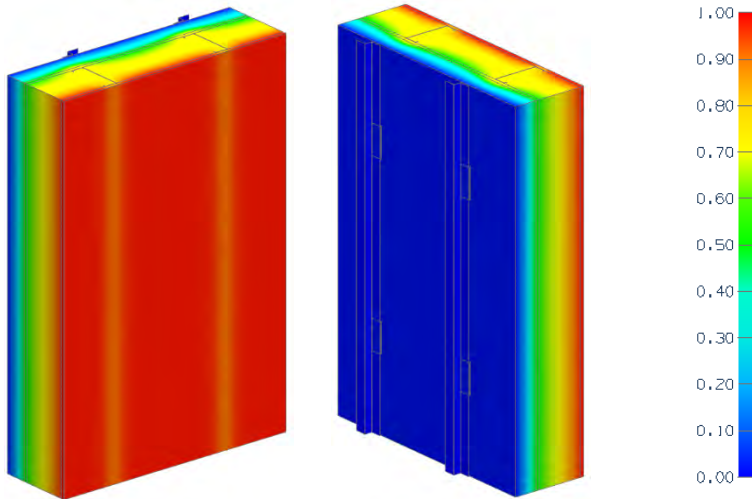

View from Interior View from Exterior

Nominal (1D) vs. Assembly Performance Indicators

Exterior Insulation 1D R-value (RSI)	R_{1D} ft ² ·hr·°F / Btu (m ² K / W)	24" Vertical Spacing		36" Vertical Spacing		48" Vertical Spacing	
		R_o ft ² ·hr·°F / Btu (m ² K / W)	U_o Btu/ft ² ·hr·°F (W/m ² K)	R_o ft ² ·hr·°F / Btu (m ² K / W)	U_o Btu/ft ² ·hr·°F (W/m ² K)	R_o ft ² ·hr·°F / Btu (m ² K / W)	U_o Btu/ft ² ·hr·°F (W/m ² K)
R-5.0 (0.88)	R-27.3 (4.80)	R-17.5 (3.08)	0.057 (0.32)	R-17.5 (3.08)	0.057 (0.32)	R-17.5 (3.09)	0.057 (0.32)
R-7.5 (1.32)	R-29.8 (5.24)	R-19.8 (3.48)*	0.051 (0.29)*	R-19.9 (3.51)*	0.050 (0.29)*	R-20.0 (3.52)*	0.050 (0.28)*
R-10.0 (1.76)	R-32.3 (5.68)	R-22.1 (3.88)*	0.045 (0.26)*	R-22.3 (3.92)*	0.045 (0.25)*	R-22.4 (3.94)*	0.045 (0.25)*
R-15.0 (2.64)	R-37.3 (6.56)	R-26.6 (4.68)	0.038 (0.21)	R-27.0 (4.75)	0.037 (0.21)	R-27.2 (4.79)	0.037 (0.21)
R-20.0 (3.52)	R-42.3 (7.44)	R-30.9 (5.45)*	0.032 (0.18)*	R-31.5 (5.56)*	0.032 (0.18)*	R-31.9 (5.61)*	0.031 (0.18)*
R-25.0 (4.40)	R-47.3 (8.33)	R-35.2 (6.19)	0.028 (0.16)	R-36.0 (6.34)	0.028 (0.16)	R-36.5 (6.42)	0.027 (0.16)
R-30.0 (5.28)	R-52.3 (9.21)	R-39.4 (6.94)*	0.025 (0.14)*	R-40.5 (7.14)*	0.025 (0.14)*	R-41.1 (7.24)*	0.024 (0.14)*
R-35.0 (6.16)	R-57.3 (10.09)	R-43.6 (7.67)	0.023 (0.13)	R-44.9 (7.91)	0.022 (0.13)	R-45.6 (8.04)	0.022 (0.12)

*Indicates interpolated value

Detail 5.1.124

Exterior and Interior Insulated 6" x 1 5/8" Steel Stud (24" o.c.) Wall Assembly with SOPREMA SOPRA-XPS 20 and ACS-S Thermal Clip Supporting Metal Cladding with R-20 Cellulose Insulation in Stud Cavity - Clear Wall

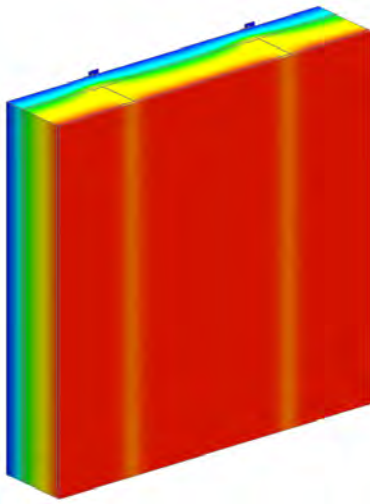

View from Interior

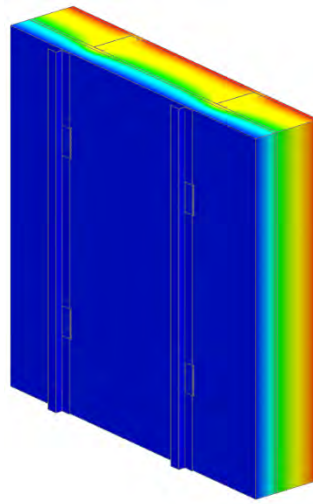

View from Exterior

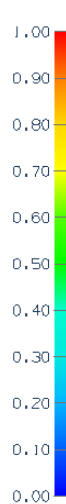

Thermal Performance Indicators

Assembly 1D (Nominal) R-Value	R_{1D}	R-22.3 (3.92 RSI) + exterior insulation
Transmittance / Resistance	U_o , R_o	"Clear wall" U- and R-value

Nominal (1D) vs. Assembly Performance Indicators

Exterior Insulation 1D R-value (RSI)	R_{1D} ft ² ·hr·°F / Btu (m ² K / W)	24" Vertical Spacing		36" Vertical Spacing		48" Vertical Spacing	
		R_o ft ² ·hr·°F / Btu (m ² K / W)	U_o Btu/ft ² ·hr·°F (W/m ² K)	R_o ft ² ·hr·°F / Btu (m ² K / W)	U_o Btu/ft ² ·hr·°F (W/m ² K)	R_o ft ² ·hr·°F / Btu (m ² K / W)	U_o Btu/ft ² ·hr·°F (W/m ² K)
R-5.0 (0.88)	R-27.3 (4.80)	R-19.9 (3.50)	0.050 (0.29)	R-19.9 (3.50)	0.050 (0.29)	R-19.9 (3.51)	0.050 (0.29)
R-7.5 (1.32)	R-29.8 (5.24)	R-22.3 (3.92)*	0.045 (0.26)*	R-22.4 (3.94)*	0.045 (0.25)*	R-22.4 (3.95)*	0.045 (0.25)*
R-10.0 (1.76)	R-32.3 (5.68)	R-24.6 (4.34)*	0.041 (0.23)*	R-24.8 (4.37)*	0.040 (0.23)*	R-24.9 (4.39)*	0.040 (0.23)*
R-15.0 (2.64)	R-37.3 (6.56)	R-29.3 (5.17)	0.034 (0.19)	R-29.7 (5.23)	0.034 (0.19)	R-29.8 (5.26)	0.034 (0.19)
R-20.0 (3.52)	R-42.3 (7.44)	R-33.9 (5.97)*	0.029 (0.17)*	R-34.4 (6.06)*	0.029 (0.17)*	R-34.7 (6.10)*	0.029 (0.16)*
R-25.0 (4.40)	R-47.3 (8.33)	R-38.4 (6.76)	0.026 (0.15)	R-39.1 (6.88)	0.026 (0.15)	R-39.4 (6.94)	0.025 (0.14)
R-30.0 (5.28)	R-52.3 (9.21)	R-42.9 (7.55)*	0.023 (0.13)*	R-43.7 (7.70)*	0.023 (0.13)*	R-44.1 (7.77)*	0.023 (0.13)*
R-35.0 (6.16)	R-57.3 (10.09)	R-47.2 (8.32)	0.021 (0.12)	R-48.2 (8.50)	0.021 (0.12)	R-48.8 (8.59)	0.020 (0.12)

*Indicates interpolated value

Detail 5.1.125

Exterior and Interior Insulated 6" x 1 5/8" Steel Stud (16" o.c.) Wall Assembly with SOPREMA SOPRA-SPF 202 and ACS-S Thermal Clip Supporting Metal Cladding with R-20 Cellulose Insulation in Stud Cavity - Clear Wall

Thermal Performance Indicators

Assembly 1D (Nominal) R-Value	R_{1D}	R-22.3 (3.92 RSI) + exterior insulation
Transmittance / Resistance	U_o , R_o	"Clear wall" U- and R-value

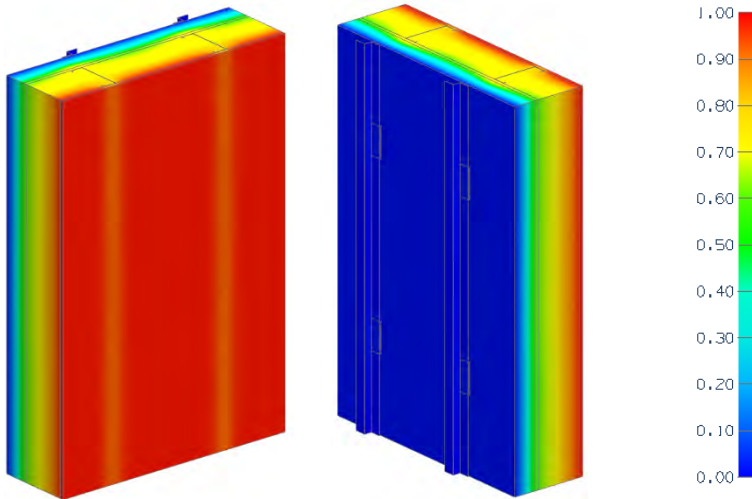

View from Interior View from Exterior

Nominal (1D) vs. Assembly Performance Indicators

Exterior Insulation 1D R-value (RSI)	R_{1D} ft ² ·hr·°F / Btu (m ² K / W)	24" Vertical Spacing		36" Vertical Spacing		48" Vertical Spacing	
		R_o ft ² ·hr·°F / Btu (m ² K / W)	U_o Btu/ft ² ·hr ·°F (W/m ² K)	R_o ft ² ·hr·°F / Btu (m ² K / W)	U_o Btu/ft ² ·hr ·°F (W/m ² K)	R_o ft ² ·hr·°F / Btu (m ² K / W)	U_o Btu/ft ² ·hr ·°F (W/m ² K)
R-6.2 (1.09)	R-28.5 (5.01)	R-18.4 (3.23)	0.054 (0.31)	R-18.4 (3.23)	0.054 (0.31)	R-18.4 (3.24)	0.054 (0.31)
R-12.4 (2.18)	R-34.7 (6.11)	R-23.9 (4.21)*	0.042 (0.24)*	R-24.2 (4.25)*	0.041 (0.24)*	R-24.3 (4.28)*	0.041 (0.23)*
R-18.6 (3.28)	R-40.9 (7.20)	R-29.4 (5.18)	0.034 (0.19)	R-29.9 (5.26)	0.033 (0.19)	R-30.2 (5.31)	0.033 (0.19)
R-24.8 (4.37)	R-47.1 (8.29)	R-34.6 (6.10)*	0.029 (0.16)*	R-35.4 (6.24)*	0.028 (0.16)*	R-35.9 (6.32)*	0.028 (0.16)*
R-31.0 (5.46)	R-53.3 (9.38)	R-39.7 (6.99)	0.025 (0.14)	R-40.9 (7.19)	0.024 (0.14)	R-41.5 (7.30)	0.024 (0.14)
R-37.2 (6.55)	R-59.5 (10.47)	R-44.8 (7.90)*	0.022 (0.13)*	R-46.3 (8.15)*	0.022 (0.12)*	R-47.1 (8.29)*	0.021 (0.12)*
R-43.4 (7.64)	R-65.7 (11.57)	R-49.8 (8.77)	0.020 (0.11)	R-51.6 (9.09)	0.019 (0.11)	R-52.6 (9.27)	0.019 (0.11)

*Indicates interpolated value

Detail 5.1.126

Exterior and Interior Insulated 6" x 1 5/8" Steel Stud (24" o.c.) Wall Assembly with SOPREMA SOPRA-SPF 202 and ACS-S Thermal Clip Supporting Metal Cladding with R-20 Cellulose Insulation in Stud Cavity - Clear Wall

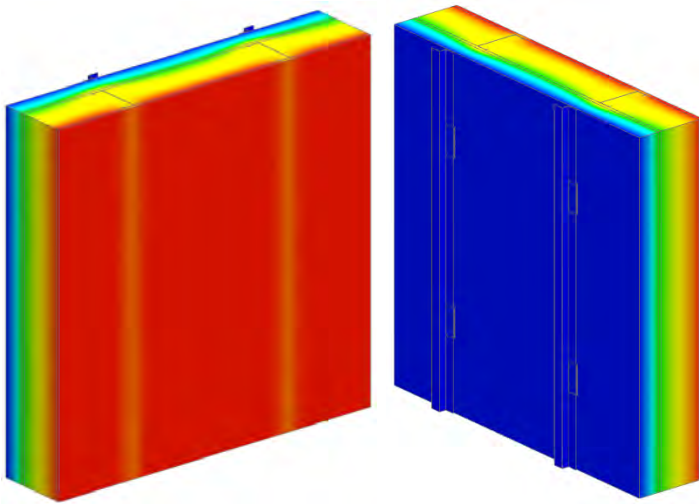

View from Interior

View from Exterior

Thermal Performance Indicators

Assembly 1D (Nominal) R-Value	R_{1D}	R-22.3 (3.92 RSI) + exterior insulation
Transmittance / Resistance	U_o , R_o	"Clear wall" U- and R-value

Nominal (1D) vs. Assembly Performance Indicators

Exterior Insulation 1D R-value (RSI)	R_{1D} ft ² ·hr·°F / Btu (m ² K / W)	24" Vertical Spacing		36" Vertical Spacing		48" Vertical Spacing	
		R_o ft ² ·hr·°F / Btu (m ² K / W)	U_o Btu/ft ² ·hr ·°F (W/m ² K)	R_o ft ² ·hr·°F / Btu (m ² K / W)	U_o Btu/ft ² ·hr ·°F (W/m ² K)	R_o ft ² ·hr·°F / Btu (m ² K / W)	U_o Btu/ft ² ·hr ·°F (W/m ² K)
R-6.2 (1.09)	R-28.5 (5.01)	R-20.8 (3.67)	0.048 (0.27)	R-20.8 (3.67)	0.048 (0.27)	R-20.8 (3.67)	0.048 (0.27)
R-12.4 (2.18)	R-34.7 (6.11)	R-26.6 (4.68)*	0.038 (0.21)*	R-26.8 (4.72)*	0.037 (0.21)*	R-26.9 (4.74)*	0.037 (0.21)*
R-18.6 (3.28)	R-40.9 (7.20)	R-32.3 (5.69)	0.031 (0.18)	R-32.7 (5.76)	0.031 (0.17)	R-32.9 (5.80)	0.030 (0.17)
R-24.8 (4.37)	R-47.1 (8.29)	R-37.8 (6.66)*	0.026 (0.15)*	R-38.5 (6.78)*	0.026 (0.15)*	R-38.8 (6.83)*	0.026 (0.15)*
R-31.0 (5.46)	R-53.3 (9.38)	R-43.3 (7.62)	0.023 (0.13)	R-44.1 (7.77)	0.023 (0.13)	R-44.6 (7.85)	0.022 (0.13)
R-37.2 (6.55)	R-59.5 (10.47)	R-48.7 (8.58)*	0.021 (0.12)*	R-49.8 (8.77)*	0.020 (0.11)*	R-50.4 (8.88)*	0.020 (0.11)*
R-43.4 (7.64)	R-65.7 (11.57)	R-54.0 (9.51)	0.019 (0.11)	R-55.4 (9.75)	0.018 (0.10)	R-56.1 (9.88)	0.018 (0.10)

*Indicates interpolated value

Detail 5.1.127

Exterior and Interior Insulated 6" x 1 5/8" Steel Stud (16" o.c.) Wall Assembly with SOPREMA SOPRA-ISO V PLUS and ACS-S Thermal Clip Supporting Metal Cladding with R-20 Cellulose Insulation in Stud Cavity - Clear Wall

Thermal Performance Indicators

Assembly 1D (Nominal) R-Value	R_{1D}	R-22.3 (3.92 RSI) + exterior insulation
Transmittance / Resistance	U_o , R_o	"Clear wall" U- and R-value

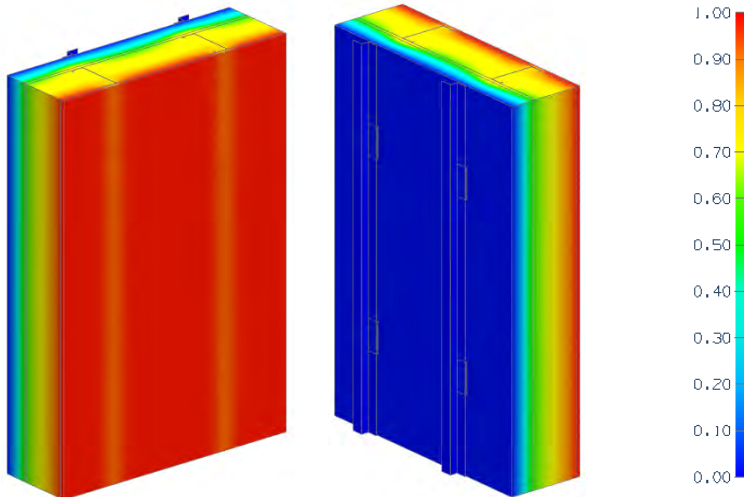

View from Interior

View from Exterior

Nominal (1D) vs. Assembly Performance Indicators

Exterior Insulation 1D R-value (RSI)	R_{1D} ft ² ·hr·°F / Btu (m ² K / W)	24" Vertical Spacing		36" Vertical Spacing		48" Vertical Spacing	
		R_o ft ² ·hr·°F / Btu (m ² K / W)	U_o Btu/ft ² ·hr ·°F (W/m ² K)	R_o ft ² ·hr·°F / Btu (m ² K / W)	U_o Btu/ft ² ·hr ·°F (W/m ² K)	R_o ft ² ·hr·°F / Btu (m ² K / W)	U_o Btu/ft ² ·hr ·°F (W/m ² K)
R-6.0 (1.06)	R-28.3 (4.98)	R-18.5 (3.26)	0.054 (0.31)	R-18.5 (3.26)	0.054 (0.31)	R-18.6 (3.27)	0.054 (0.31)
R-9.0 (1.59)	R-31.3 (5.51)	R-21.2 (3.74)*	0.047 (0.27)*	R-21.4 (3.77)*	0.047 (0.27)*	R-21.5 (3.78)*	0.047 (0.26)*
R-12.0 (2.11)	R-34.3 (6.04)	R-23.9 (4.21)*	0.042 (0.24)*	R-24.2 (4.26)*	0.041 (0.23)*	R-24.3 (4.28)*	0.041 (0.23)*
R-15.0 (2.64)	R-37.3 (6.56)	R-26.5 (4.67)*	0.038 (0.21)*	R-27.0 (4.75)*	0.037 (0.21)*	R-27.2 (4.79)*	0.037 (0.21)*
R-18.0 (3.17)	R-40.3 (7.09)	R-29.2 (5.15)	0.034 (0.19)	R-29.8 (5.24)	0.034 (0.19)	R-30.0 (5.29)	0.033 (0.19)
R-21.0 (3.70)	R-43.3 (7.62)	R-31.7 (5.59)*	0.031 (0.18)*	R-32.4 (5.71)*	0.031 (0.18)*	R-32.8 (5.78)*	0.030 (0.17)*
R-24.0 (4.23)	R-46.3 (8.15)	R-34.3 (6.04)*	0.029 (0.17)*	R-35.1 (6.19)*	0.028 (0.16)*	R-35.6 (6.27)*	0.028 (0.16)*
R-27.0 (4.76)	R-49.3 (8.68)	R-36.8 (6.49)*	0.027 (0.15)*	R-37.8 (6.66)*	0.026 (0.15)*	R-38.3 (6.75)*	0.026 (0.15)*
R-30.0 (5.28)	R-52.3 (9.21)	R-39.3 (6.92)	0.025 (0.14)	R-40.4 (7.12)	0.025 (0.14)	R-41.0 (7.23)	0.024 (0.14)
R-33.0 (5.81)	R-55.3 (9.73)	R-41.8 (7.37)*	0.024 (0.14)*	R-43.1 (7.59)*	0.023 (0.13)*	R-43.8 (7.72)*	0.023 (0.13)*
R-36.0 (6.34)	R-58.3 (10.26)	R-44.3 (7.80)*	0.023 (0.13)*	R-45.7 (8.05)*	0.022 (0.12)*	R-46.5 (8.19)*	0.022 (0.12)*
R-39.0 (6.87)	R-61.3 (10.79)	R-46.7 (8.22)*	0.021 (0.12)*	R-48.3 (8.51)*	0.021 (0.12)*	R-49.2 (8.66)*	0.020 (0.12)*
R-42.0 (7.40)	R-64.3 (11.32)	R-49.1 (8.65)	0.020 (0.12)	R-50.9 (8.97)	0.020 (0.11)	R-51.9 (9.13)	0.019 (0.11)

*Indicates interpolated value

Detail 5.1.128

Exterior and Interior Insulated 6" x 1 5/8" Steel Stud (24" o.c.) Wall Assembly with SOPREMA SOPRA-ISO V PLUS and ACS-S Thermal Clip Supporting Metal Cladding with R-20 Cellulose Insulation in Stud Cavity - Clear Wall

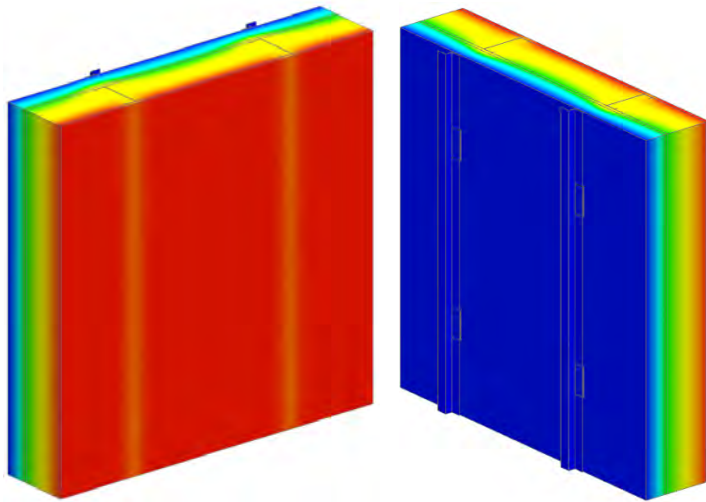

View from Interior

View from Exterior

Thermal Performance Indicators

Assembly 1D (Nominal) R-Value	R_{1D}	R-22.3 (3.92 RSI) + exterior insulation
Transmittance / Resistance	U_o , R_o	"Clear wall" U- and R-value

Nominal (1D) vs. Assembly Performance Indicators

Exterior Insulation 1D R-value (RSI)	R_{1D} ft ² ·hr·°F / Btu (m ² K / W)	24" Vertical Spacing		36" Vertical Spacing		48" Vertical Spacing	
		R_o ft ² ·hr·°F / Btu (m ² K / W)	U_o Btu/ft ² ·hr ·°F (W/m ² K)	R_o ft ² ·hr·°F / Btu (m ² K / W)	U_o Btu/ft ² ·hr ·°F (W/m ² K)	R_o ft ² ·hr·°F / Btu (m ² K / W)	U_o Btu/ft ² ·hr ·°F (W/m ² K)
R-6.0 (1.06)	R-28.3 (4.98)	R-20.9 (3.68)	0.048 (0.27)	R-20.9 (3.69)	0.048 (0.27)	R-21.0 (3.69)	0.048 (0.27)
R-9.0 (1.59)	R-31.3 (5.51)	R-23.7 (4.18)*	0.042 (0.24)*	R-23.9 (4.21)*	0.042 (0.24)*	R-23.9 (4.22)*	0.042 (0.24)*
R-12.0 (2.11)	R-34.3 (6.04)	R-26.5 (4.67)*	0.038 (0.21)*	R-26.8 (4.72)*	0.037 (0.21)*	R-26.9 (4.74)*	0.037 (0.21)*
R-15.0 (2.64)	R-37.3 (6.56)	R-29.3 (5.16)*	0.034 (0.19)*	R-29.7 (5.22)*	0.034 (0.19)*	R-29.8 (5.25)*	0.034 (0.19)*
R-18.0 (3.17)	R-40.3 (7.09)	R-32.1 (5.65)	0.031 (0.18)	R-32.5 (5.73)	0.031 (0.17)	R-32.8 (5.77)	0.031 (0.17)
R-21.0 (3.70)	R-43.3 (7.62)	R-34.8 (6.13)*	0.029 (0.16)*	R-35.3 (6.22)*	0.028 (0.16)*	R-35.6 (6.27)*	0.028 (0.16)*
R-24.0 (4.23)	R-46.3 (8.15)	R-37.5 (6.60)*	0.027 (0.15)*	R-38.1 (6.72)*	0.026 (0.15)*	R-38.5 (6.77)*	0.026 (0.15)*
R-27.0 (4.76)	R-49.3 (8.68)	R-40.2 (7.07)*	0.025 (0.14)*	R-40.9 (7.21)*	0.024 (0.14)*	R-41.3 (7.28)*	0.024 (0.14)*
R-30.0 (5.28)	R-52.3 (9.21)	R-42.8 (7.53)	0.023 (0.13)	R-43.7 (7.69)	0.023 (0.13)	R-44.1 (7.77)	0.023 (0.13)
R-33.0 (5.81)	R-55.3 (9.73)	R-45.4 (8.00)*	0.022 (0.12)*	R-46.4 (8.18)*	0.022 (0.12)*	R-46.9 (8.27)*	0.021 (0.12)*
R-36.0 (6.34)	R-58.3 (10.26)	R-48.0 (8.46)*	0.021 (0.12)*	R-49.2 (8.66)*	0.020 (0.12)*	R-49.7 (8.76)*	0.020 (0.11)*
R-39.0 (6.87)	R-61.3 (10.79)	R-50.6 (8.91)*	0.020 (0.11)*	R-51.9 (9.13)*	0.019 (0.11)*	R-52.5 (9.25)*	0.019 (0.11)*
R-42.0 (7.40)	R-64.3 (11.32)	R-53.2 (9.37)	0.019 (0.11)	R-54.5 (9.61)	0.018 (0.10)	R-55.3 (9.73)	0.018 (0.10)

*Indicates interpolated value

Detail 5.1.129

Exterior and Interior Insulated 6" x 1 5/8" Steel Stud (16" o.c.) Wall Assembly with Mineral Wool and ACS-S Thermal Clip Supporting Metal Cladding with R-20 Cellulose Insulation in Stud Cavity - Clear Wall

Thermal Performance Indicators

Assembly 1D (Nominal) R-Value	R_{1D}	R-22.3 (3.92 RSI) + exterior insulation
Transmittance / Resistance	U_o , R_o	"Clear wall" U- and R-value

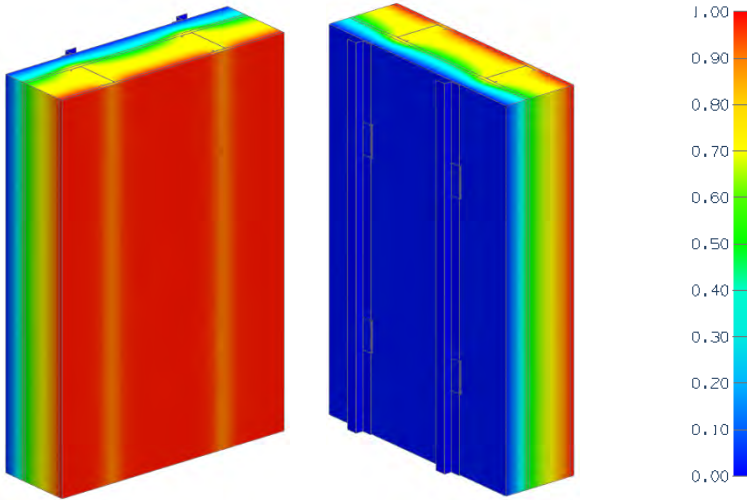

View from Interior View from Exterior

Nominal (1D) vs. Assembly Performance Indicators

Exterior Insulation 1D R-value (RSI)	R_{1D} ft ² ·hr·°F / Btu (m ² K / W)	24" Vertical Spacing		36" Vertical Spacing		48" Vertical Spacing	
		R_o ft ² ·hr·°F / Btu (m ² K / W)	U_o Btu/ft ² ·hr ·°F (W/m ² K)	R_o ft ² ·hr·°F / Btu (m ² K / W)	U_o Btu/ft ² ·hr ·°F (W/m ² K)	R_o ft ² ·hr·°F / Btu (m ² K / W)	U_o Btu/ft ² ·hr ·°F (W/m ² K)
R-4.3 (0.76)	R-26.6 (4.68)	R-16.8 (2.95)	0.060 (0.34)	R-16.8 (2.95)	0.060 (0.34)	R-16.8 (2.96)	0.060 (0.34)
R-8.6 (1.51)	R-30.9 (5.44)	R-20.7 (3.65)*	0.048 (0.27)*	R-20.9 (3.68)*	0.048 (0.27)*	R-21.0 (3.70)*	0.048 (0.27)*
R-12.9 (2.27)	R-35.2 (6.19)	R-24.7 (4.35)	0.040 (0.23)	R-25.0 (4.41)	0.040 (0.23)	R-25.2 (4.44)	0.040 (0.23)
R-17.2 (3.03)	R-39.5 (6.95)	R-28.5 (5.01)*	0.035 (0.20)*	R-29.0 (5.10)*	0.035 (0.20)*	R-29.2 (5.15)*	0.034 (0.19)*
R-21.5 (3.79)	R-43.8 (7.71)	R-32.2 (5.67)	0.031 (0.18)	R-32.9 (5.79)	0.030 (0.17)	R-33.2 (5.85)	0.030 (0.17)
R-25.8 (4.54)	R-48.1 (8.47)	R-36.0 (6.34)*	0.028 (0.16)*	R-36.8 (6.49)*	0.027 (0.15)*	R-37.3 (6.57)*	0.027 (0.15)*
R-30.1 (5.30)	R-52.4 (9.22)	R-39.7 (6.99)*	0.025 (0.14)*	R-40.7 (7.17)*	0.025 (0.14)*	R-41.3 (7.27)*	0.024 (0.14)*
R-34.4 (6.06)	R-56.7 (9.98)	R-43.3 (7.63)	0.023 (0.13)	R-44.6 (7.85)	0.022 (0.13)	R-45.2 (7.96)	0.022 (0.13)

*Indicates interpolated value

Detail 5.1.130

Exterior and Interior Insulated 6" x 1 5/8" Steel Stud (24" o.c.) Wall Assembly with Mineral Wool and ACS-S Thermal Clip Supporting Metal Cladding with R-20 Cellulose Insulation in Stud Cavity - Clear Wall

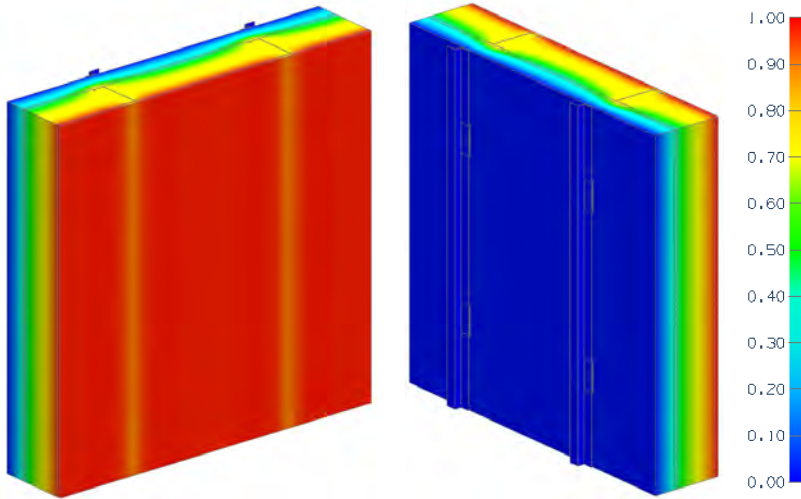

View from Interior

View from Exterior

Thermal Performance Indicators

Assembly 1D (Nominal) R-Value	R_{1D}	R-22.3 (3.92 RSI) + exterior insulation
Transmittance / Resistance	U_o , R_o	"Clear wall" U- and R-value

Nominal (1D) vs. Assembly Performance Indicators

Exterior Insulation 1D R-value (RSI)	R_{1D} ft ² ·hr·°F / Btu (m ² K / W)	24" Vertical Spacing		36" Vertical Spacing		48" Vertical Spacing	
		R_o ft ² ·hr·°F / Btu (m ² K / W)	U_o Btu/ft ² ·hr ·°F (W/m ² K)	R_o ft ² ·hr·°F / Btu (m ² K / W)	U_o Btu/ft ² ·hr ·°F (W/m ² K)	R_o ft ² ·hr·°F / Btu (m ² K / W)	U_o Btu/ft ² ·hr ·°F (W/m ² K)
R-4.3 (0.76)	R-26.6 (4.68)	R-19.1 (3.37)	0.052 (0.30)	R-19.1 (3.37)	0.052 (0.30)	R-19.1 (3.37)	0.052 (0.30)
R-8.6 (1.51)	R-30.9 (5.44)	R-23.3 (4.10)*	0.043 (0.24)*	R-23.4 (4.12)*	0.043 (0.24)*	R-23.5 (4.13)*	0.043 (0.24)*
R-12.9 (2.27)	R-35.2 (6.19)	R-27.4 (4.82)	0.037 (0.21)	R-27.7 (4.87)	0.036 (0.21)	R-27.8 (4.89)	0.036 (0.20)
R-17.2 (3.03)	R-39.5 (6.95)	R-31.3 (5.52)*	0.032 (0.18)*	R-31.7 (5.59)*	0.032 (0.18)*	R-31.9 (5.62)*	0.031 (0.18)*
R-21.5 (3.79)	R-43.8 (7.71)	R-35.2 (6.21)	0.028 (0.16)	R-35.8 (6.30)	0.028 (0.16)	R-36.1 (6.35)	0.028 (0.16)
R-25.8 (4.54)	R-48.1 (8.47)	R-39.2 (6.91)*	0.026 (0.14)*	R-39.9 (7.02)*	0.025 (0.14)*	R-40.2 (7.08)*	0.025 (0.14)*
R-30.1 (5.30)	R-52.4 (9.22)	R-43.1 (7.59)*	0.023 (0.13)*	R-43.9 (7.73)*	0.023 (0.13)*	R-44.3 (7.80)*	0.023 (0.13)*
R-34.4 (6.06)	R-56.7 (9.98)	R-46.9 (8.26)	0.021 (0.12)	R-47.8 (8.42)	0.021 (0.12)	R-48.3 (8.51)	0.021 (0.12)

*Indicates interpolated value

Detail 5.1.131

Exterior Insulated 6" x 1 5/8" Steel Stud (16" o.c.) Wall Assembly with Protected SOPREMA SOPRA-ISO V ALU and ACS-S Thermal Clip Supporting Metal Cladding - Clear Wall

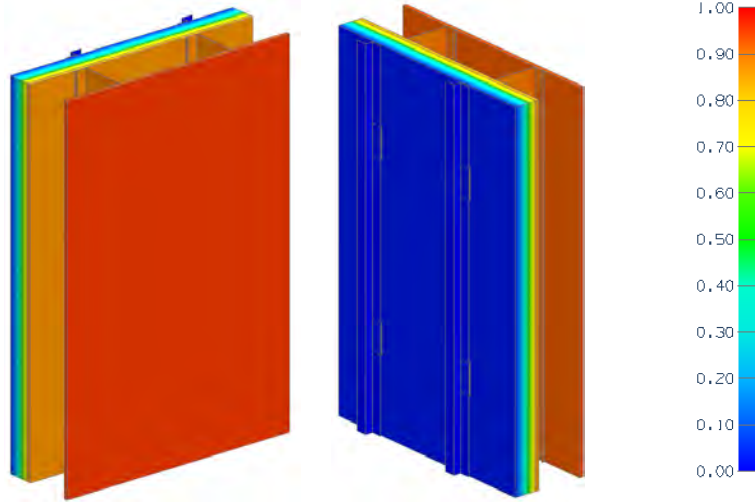

Thermal Performance Indicators

Assembly 1D (Nominal) R-Value	R _{1D}	R-3.2 (0.56 RSI) + exterior insulation
Transmittance / Resistance	U _o , R _o	"Clear wall" U- and R-value

View from Interior View from Exterior

Nominal (1D) vs. Assembly Performance Indicators

Exterior Insulation 1D R-value (RSI)	R _{1D} ft ² ·hr·°F / Btu (m ² K / W)	24" Vertical Spacing		36" Vertical Spacing		48" Vertical Spacing	
		R _o ft ² ·hr·°F / Btu (m ² K / W)	U _o Btu/ft ² ·hr ·°F (W/m ² K)	R _o ft ² ·hr·°F / Btu (m ² K / W)	U _o Btu/ft ² ·hr ·°F (W/m ² K)	R _o ft ² ·hr·°F / Btu (m ² K / W)	U _o Btu/ft ² ·hr ·°F (W/m ² K)
R-15.1 (2.66)	R-18.3 (3.22)	R-17.5 (3.08)	0.057 (0.32)	R-17.8 (3.13)	0.056 (0.32)	R-17.9 (3.15)	0.056 (0.32)
R-18.4 (3.23)	R-21.5 (3.79)	R-20.3 (3.58)*	0.049 (0.28)*	R-20.7 (3.65)*	0.048 (0.27)*	R-20.9 (3.69)*	0.048 (0.27)*
R-21.6 (3.80)	R-24.8 (4.36)	R-23.2 (4.08)	0.043 (0.24)	R-23.7 (4.17)	0.042 (0.24)	R-24.0 (4.22)	0.042 (0.24)
R-24.9 (4.38)	R-28.0 (4.93)	R-26.0 (4.57)*	0.039 (0.22)*	R-26.6 (4.69)*	0.038 (0.21)*	R-27.0 (4.75)*	0.037 (0.21)*
R-28.1 (4.95)	R-31.3 (5.51)	R-28.7 (5.05)	0.035 (0.20)	R-29.5 (5.19)	0.034 (0.19)	R-29.9 (5.27)	0.033 (0.19)
R-31.4 (5.52)	R-34.5 (6.08)	R-31.4 (5.54)*	0.032 (0.18)*	R-32.4 (5.71)*	0.031 (0.18)*	R-32.9 (5.79)*	0.030 (0.17)*
R-34.6 (6.09)	R-37.8 (6.65)	R-34.2 (6.02)	0.029 (0.17)	R-35.3 (6.22)	0.028 (0.16)	R-35.9 (6.32)	0.028 (0.16)
R-37.9 (6.67)	R-41.0 (7.22)	R-36.8 (6.48)*	0.027 (0.15)*	R-38.1 (6.71)*	0.026 (0.15)*	R-38.8 (6.83)*	0.026 (0.15)*
R-41.1 (7.24)	R-44.3 (7.80)	R-39.4 (6.94)	0.025 (0.14)	R-40.9 (7.20)	0.024 (0.14)	R-41.7 (7.34)	0.024 (0.14)
R-47.6 (8.38)	R-50.8 (8.94)	R-44.6 (7.85)**	0.022 (0.13)**	R-46.5 (8.18)**	0.022 (0.12)**	R-47.5 (8.36)**	0.021 (0.12)**

*Indicates interpolated value

**Indicates extrapolated value

Detail 5.1.132

Exterior Insulated 6" x 1 5/8" Steel Stud (24" o.c.) Wall Assembly with Protected SOPREMA SOPRA-ISO V ALU and ACS-S Thermal Clip Supporting Metal Cladding - Clear Wall

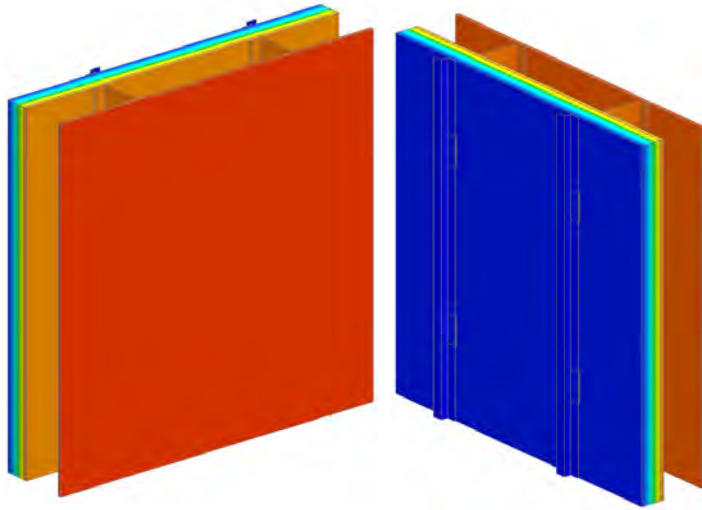

Thermal Performance Indicators

Assembly 1D (Nominal) R-Value	R_{1D}	R-3.2 (0.56 RSI) + exterior insulation
Transmittance / Resistance	U_o , R_o	"Clear wall" U- and R-value

View from Interior

View from Exterior

Nominal (1D) vs. Assembly Performance Indicators

Exterior Insulation 1D R-value (RSI)	R_{1D} ft ² ·hr·°F / Btu (m ² K / W)	24" Vertical Spacing		36" Vertical Spacing		48" Vertical Spacing	
		R_o ft ² ·hr·°F / Btu (m ² K / W)	U_o Btu/ft ² ·hr ·°F (W/m ² K)	R_o ft ² ·hr·°F / Btu (m ² K / W)	U_o Btu/ft ² ·hr ·°F (W/m ² K)	R_o ft ² ·hr·°F / Btu (m ² K / W)	U_o Btu/ft ² ·hr ·°F (W/m ² K)
R-15.1 (2.66)	R-18.3 (3.22)	R-17.8 (3.13)	0.056 (0.32)	R-18.0 (3.17)	0.056 (0.32)	R-18.1 (3.18)	0.055 (0.31)
R-18.4 (3.23)	R-21.5 (3.79)	R-20.8 (3.65)*	0.048 (0.27)*	R-21.0 (3.70)*	0.048 (0.27)*	R-21.2 (3.73)*	0.047 (0.27)*
R-21.6 (3.80)	R-24.8 (4.36)	R-23.7 (4.18)	0.042 (0.24)	R-24.1 (4.24)	0.042 (0.24)	R-24.2 (4.27)	0.041 (0.23)
R-24.9 (4.38)	R-28.0 (4.93)	R-26.6 (4.69)*	0.038 (0.21)*	R-27.1 (4.77)*	0.037 (0.21)*	R-27.3 (4.81)*	0.037 (0.21)*
R-28.1 (4.95)	R-31.3 (5.51)	R-29.5 (5.20)	0.034 (0.19)	R-30.1 (5.30)	0.033 (0.19)	R-30.4 (5.35)	0.033 (0.19)
R-31.4 (5.52)	R-34.5 (6.08)	R-32.4 (5.71)*	0.031 (0.18)*	R-33.1 (5.83)*	0.030 (0.17)*	R-33.4 (5.89)*	0.030 (0.17)*
R-34.6 (6.09)	R-37.8 (6.65)	R-35.3 (6.22)	0.028 (0.16)	R-36.1 (6.36)	0.028 (0.16)	R-36.5 (6.43)	0.027 (0.16)
R-37.9 (6.67)	R-41.0 (7.22)	R-38.1 (6.71)*	0.026 (0.15)*	R-39.0 (6.87)*	0.026 (0.15)*	R-39.5 (6.96)*	0.025 (0.14)*
R-41.1 (7.24)	R-44.3 (7.80)	R-40.9 (7.21)	0.024 (0.14)	R-42.0 (7.39)	0.024 (0.14)	R-42.5 (7.49)	0.024 (0.13)
R-47.6 (8.38)	R-50.8 (8.94)	R-46.5 (8.19)**	0.022 (0.12)**	R-47.8 (8.43)**	0.021 (0.12)**	R-48.6 (8.56)**	0.021 (0.12)**

*Indicates interpolated value

**Indicates extrapolated value

Detail 5.1.133

Exterior and Interior Insulated 6" x 1 5/8" Steel Stud (16" o.c.) Wall Assembly with Protected SOPREMA SOPRA-ISO V PLUS and ACS-S Thermal Clip Supporting Metal Cladding with R-20 Cellulose Insulation in Stud Cavity - Clear Wall

Thermal Performance Indicators

Assembly 1D (Nominal) R-Value	R_{1D}	R-22.3 (3.92 RSI) + exterior insulation
Transmittance / Resistance	U_o , R_o	"Clear wall" U- and R-value

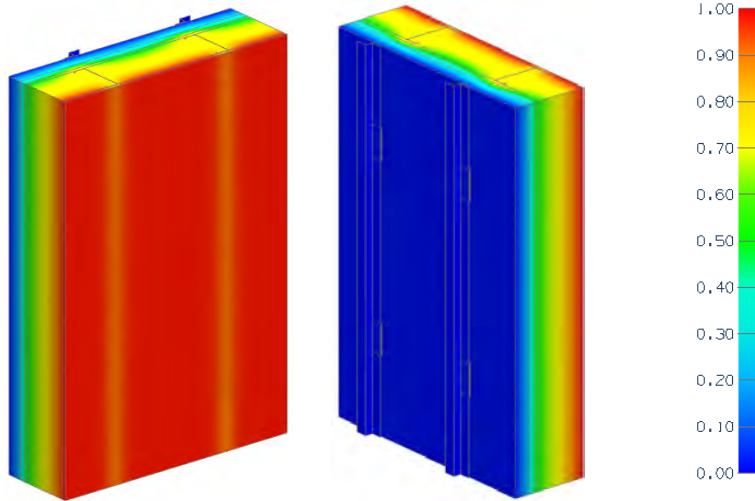

View from Interior

View from Exterior

Nominal (1D) vs. Assembly Performance Indicators

Exterior Insulation 1D R-value (RSI)	R_{1D} ft ² ·hr·°F / Btu (m ² K / W)	24" Vertical Spacing		36" Vertical Spacing		48" Vertical Spacing	
		R_o ft ² ·hr·°F / Btu (m ² K / W)	U_o Btu/ft ² ·hr ·°F (W/m ² K)	R_o ft ² ·hr·°F / Btu (m ² K / W)	U_o Btu/ft ² ·hr ·°F (W/m ² K)	R_o ft ² ·hr·°F / Btu (m ² K / W)	U_o Btu/ft ² ·hr ·°F (W/m ² K)
R-14.6 (2.57)	R-36.9 (6.49)	R-26.5 (4.66)	0.038 (0.21)	R-26.8 (4.72)	0.037 (0.21)	R-27.0 (4.75)	0.037 (0.21)
R-17.6 (3.10)	R-39.9 (7.02)	R-29.1 (5.12)*	0.034 (0.20)*	R-29.5 (5.20)*	0.034 (0.19)*	R-29.8 (5.25)*	0.034 (0.19)*
R-20.6 (3.63)	R-42.9 (7.55)	R-31.7 (5.58)	0.032 (0.18)	R-32.3 (5.68)	0.031 (0.18)	R-32.6 (5.74)	0.031 (0.17)
R-23.6 (4.16)	R-45.9 (8.08)	R-34.2 (6.02)*	0.029 (0.17)*	R-34.9 (6.15)*	0.029 (0.16)*	R-35.3 (6.22)*	0.028 (0.16)*
R-26.6 (4.68)	R-48.9 (8.61)	R-36.7 (6.46)	0.027 (0.15)	R-37.6 (6.62)	0.027 (0.15)	R-38.1 (6.70)	0.026 (0.15)
R-29.6 (5.21)	R-51.9 (9.14)	R-39.2 (6.91)*	0.026 (0.14)*	R-40.3 (7.09)*	0.025 (0.14)*	R-40.8 (7.19)*	0.024 (0.14)*
R-32.6 (5.74)	R-54.9 (9.66)	R-41.7 (7.34)*	0.024 (0.14)*	R-42.9 (7.56)*	0.023 (0.13)*	R-43.6 (7.67)*	0.023 (0.13)*
R-35.6 (6.27)	R-57.9 (10.19)	R-44.2 (7.78)*	0.023 (0.13)*	R-45.5 (8.02)*	0.022 (0.12)*	R-46.3 (8.15)*	0.022 (0.12)*
R-38.6 (6.80)	R-60.9 (10.72)	R-46.6 (8.21)	0.021 (0.12)	R-48.1 (8.48)	0.021 (0.12)	R-49.0 (8.62)	0.020 (0.12)

*Indicates interpolated value

Detail 5.1.134

Exterior and Interior Insulated 6" x 1 5/8" Steel Stud (24" o.c.) Wall Assembly with Protected SOPREMA SOPRA-ISO V PLUS and ACS-S Thermal Clip Supporting Metal Cladding with R-20 Cellulose Insulation in Stud Cavity - Clear Wall

Thermal Performance Indicators

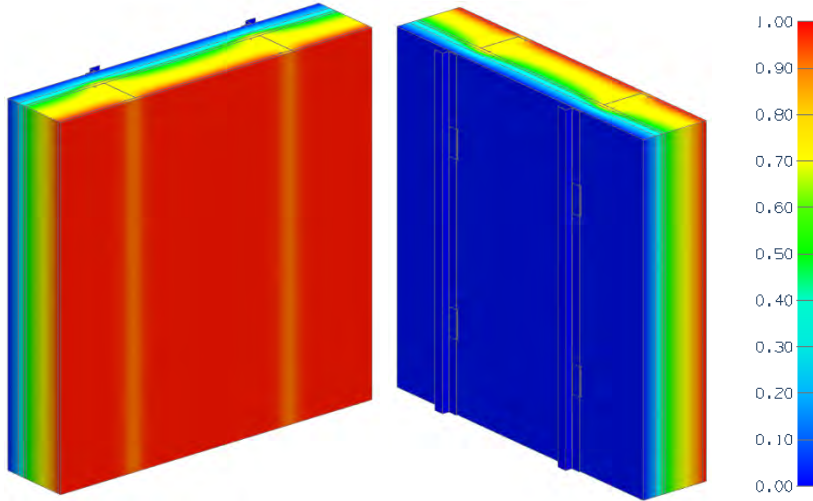

Assembly 1D (Nominal) R-Value	R _{1D}	R-22.3 (3.92 RSI) + exterior insulation
Transmittance / Resistance	U _o , R _o	"Clear wall" U- and R-value

View from Interior

View from Exterior

Nominal (1D) vs. Assembly Performance Indicators

Exterior Insulation 1D R-value (RSI)	R _{1D} ft ² ·hr·°F / Btu (m ² K / W)	24" Vertical Spacing		36" Vertical Spacing		48" Vertical Spacing	
		R _o ft ² ·hr·°F / Btu (m ² K / W)	U _o Btu/ft ² ·hr ·°F (W/m ² K)	R _o ft ² ·hr·°F / Btu (m ² K / W)	U _o Btu/ft ² ·hr ·°F (W/m ² K)	R _o ft ² ·hr·°F / Btu (m ² K / W)	U _o Btu/ft ² ·hr ·°F (W/m ² K)
R-14.6 (2.57)	R-36.9 (6.49)	R-29.2 (5.14)	0.034 (0.19)	R-29.5 (5.19)	0.034 (0.19)	R-29.6 (5.22)	0.034 (0.19)
R-17.6 (3.10)	R-39.9 (7.02)	R-31.9 (5.62)*	0.031 (0.18)*	R-32.3 (5.69)*	0.031 (0.18)*	R-32.5 (5.72)*	0.031 (0.17)*
R-20.6 (3.63)	R-42.9 (7.55)	R-34.6 (6.10)	0.029 (0.16)	R-35.1 (6.18)	0.028 (0.16)	R-35.4 (6.23)	0.028 (0.16)
R-23.6 (4.16)	R-45.9 (8.08)	R-37.3 (6.57)*	0.027 (0.15)*	R-37.9 (6.67)*	0.026 (0.15)*	R-38.2 (6.72)*	0.026 (0.15)*
R-26.6 (4.68)	R-48.9 (8.61)	R-39.9 (7.03)	0.025 (0.14)	R-40.6 (7.16)	0.025 (0.14)	R-41.0 (7.22)	0.024 (0.14)
R-29.6 (5.21)	R-51.9 (9.14)	R-42.6 (7.51)*	0.023 (0.13)*	R-43.4 (7.65)*	0.023 (0.13)*	R-43.8 (7.72)*	0.023 (0.13)*
R-32.6 (5.74)	R-54.9 (9.66)	R-45.3 (7.97)*	0.022 (0.13)*	R-46.2 (8.13)*	0.022 (0.12)*	R-46.7 (8.22)*	0.021 (0.12)*
R-35.6 (6.27)	R-57.9 (10.19)	R-47.9 (8.43)*	0.021 (0.12)*	R-48.9 (8.61)*	0.020 (0.12)*	R-49.5 (8.71)*	0.020 (0.11)*
R-38.6 (6.80)	R-60.9 (10.72)	R-50.5 (8.89)	0.020 (0.11)	R-51.6 (9.09)	0.019 (0.11)	R-52.3 (9.20)	0.019 (0.11)

*Indicates interpolated value

Detail 5.1.135

Exterior Insulated 6" x 1 5/8" Steel Stud (16" o.c.) Wall Assembly with U-Kon ND-062 Brackets and Vertical Rail System Supporting Metal Cladding - Clear Wall

Thermal Performance Indicators

Assembly 1D (Nominal) R-Value	R_{1D}	R-3.30 (0.58 RSI) + exterior insulation
Transmittance / Resistance	U_o , R_o	"Clear wall" U- and R-value

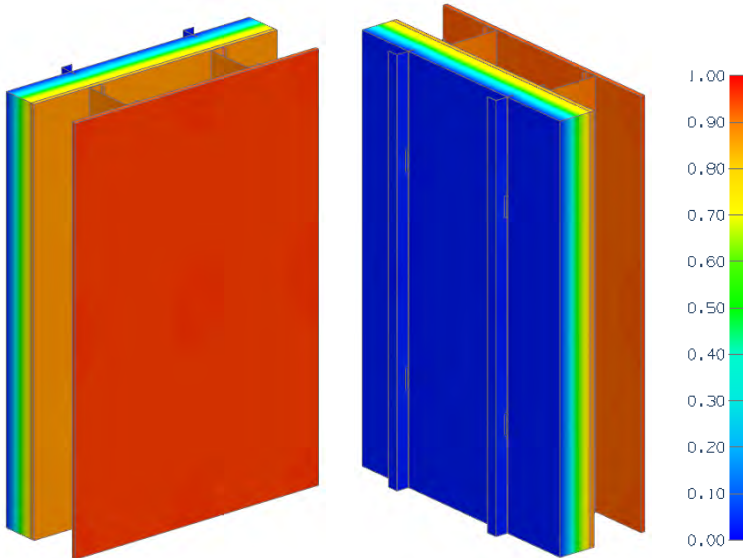

View from Interior

View from Exterior

Nominal (1D) vs. Assembly Performance Indicators

Exterior Insulation 1D R-Value (RSI)	R_{1D} ft ² ·hr·°F / Btu (m ² K / W)	24" Vertical Clip Spacing		36" Vertical Clip Spacing		48" Vertical Clip Spacing	
		R_o ft ² ·hr·°F / Btu (m ² K / W)	U_o Btu/ft ² ·hr·°F (W/m ² K)	R_o ft ² ·hr·°F / Btu (m ² K / W)	U_o Btu/ft ² ·hr·°F (W/m ² K)	R_o ft ² ·hr·°F / Btu (m ² K / W)	U_o Btu/ft ² ·hr·°F (W/m ² K)
R-12.6 (2.22)	R-15.9 (2.80)	R-14.2 (2.50)	0.070 (0.40)	R-14.7 (2.58)	0.068 (0.39)	R-14.9 (2.62)	0.067 (0.38)
R-16.8 (2.96)	R-20.1 (3.54)	R-17.7 (3.11)	0.057 (0.32)	R-18.3 (3.23)	0.055 (0.31)	R-18.7 (3.29)	0.054 (0.30)
R-21.0 (3.70)	R-24.3 (4.28)	R-21.1 (3.71)	0.047 (0.27)	R-21.9 (3.86)	0.046 (0.26)	R-22.4 (3.94)	0.045 (0.25)
R-25.2 (4.44)	R-28.5 (5.02)	R-24.8 (4.37)	0.040 (0.23)	R-25.8 (4.54)	0.039 (0.22)	R-26.3 (4.64)	0.038 (0.22)
R-42.0 (7.40)	R-45.3 (7.98)	R-38.9 (6.86)	0.026 (0.15)	R-40.7 (7.17)	0.025 (0.14)	R-41.7 (7.34)	0.024 (0.14)

Detail 5.2.1

Exterior Insulated 3 5/8" x 1 5/8" Steel Stud (16" o.c.) Wall Assembly with Horizontal Z-Girts (24" o.c.) Supporting Metal Cladding – Intermediate Floor Intersection

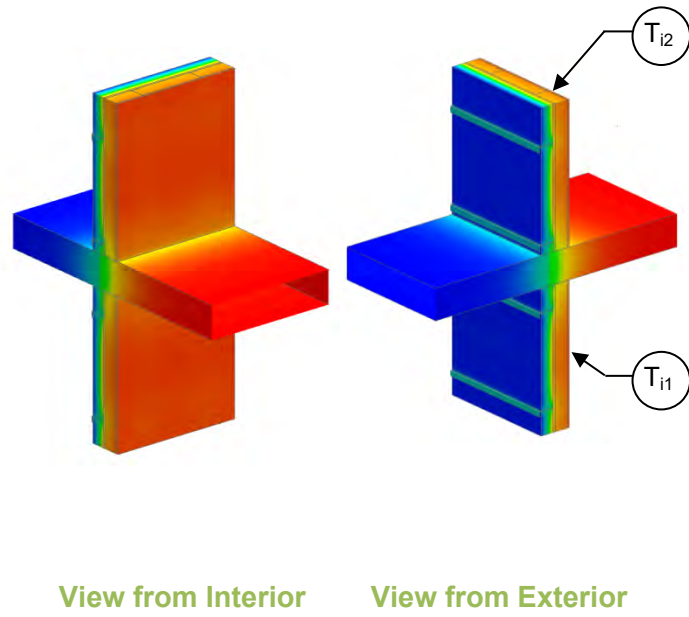

Thermal Performance Indicators

Assembly 1D (Nominal) R-Value	R_{1D}	R-3.2 (0.56 RSI) + exterior insulation
Transmittance / Resistance without Anomaly	U_o, R_o	“clear wall” U- and R-value without slab
Transmittance / Resistance	U, R	U- and R-values for overall assembly
Surface Temperature Index ¹	T_i	0 = exterior temperature 1 = interior temperature
Linear Transmittance	ψ	Incremental increase in transmittance per linear length of slab

¹Assumptions and limitations for surface temperatures identified in ASHRAE 1365-RP

View from Interior View from Exterior

Nominal (1D) vs. Assembly Performance Indicators

Exterior Insulation 1D R-Value (RSI)	R_{1D} ft ² ·hr·°F / Btu (m ² K / W)	R_o ft ² ·hr·°F / Btu (m ² K / W)	U_o Btu/ft ² ·hr ·°F (W/m ² K)	R ft ² ·hr·°F / Btu (m ² K / W)	U Btu/ft ² ·hr ·°F (W/m ² K)	ψ Btu/ft hr °F (W/m K)
R-5 (0.88)	R-8.2 (1.44)	R-6.9 (1.21)	0.146 (0.83)	R-4.74 (0.83)	0.211 (1.20)	0.433 (0.749)
R-15 (2.64)	R-18.2 (3.20)	R-11.3 (1.99)	0.088 (0.50)	R-6.45 (1.14)	0.155 (0.88)	0.445 (0.770)
R-25 (4.40)	R-28.2 (4.96)	R-14.6 (2.56)	0.069 (0.39)	R-7.61 (1.34)	0.131 (0.75)	0.418 (0.724)

Temperature Indices

	R5	R15	R25	
T_{i1}	0.50	0.58	0.63	Min T on sheathing, at slab, between studs
T_{i2}	0.73	0.84	0.88	Max T on sheathing, at studs, between girts

Detail 5.2.2

Exterior Insulated 3 5/8" x 1 5/8" Steel Stud (16" o.c.) Wall Assembly with Horizontal Z-Girts (24" o.c.) Supporting Metal Cladding – Intermediate Floor Intersection with Top Side Insulation

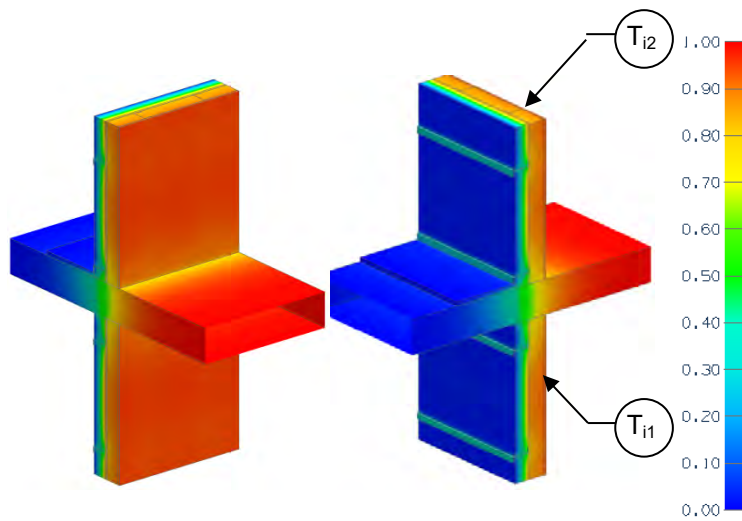

Thermal Performance Indicators

Assembly 1D (Nominal) R-Value	R_{1D}	R-3.2 (0.56 RSI) + exterior insulation
Transmittance / Resistance without Anomaly	U_o , R_o	"clear wall" U- and R-value, without slab
Transmittance / Resistance	U, R	U- and R-values for overall assembly
Surface Temperature Index ¹	T_i	0 = exterior temperature 1 = interior temperature
Linear Transmittance	ψ	Incremental increase in transmittance per linear length of slab

¹Assumptions and limitations for surface temperatures identified in ASHRAE 1365-RP

View from Interior View from Exterior

Nominal (1D) vs. Assembly Performance Indicators

Base Assembly –Wall

Exterior Insulation 1D R-Value (RSI)	R_{1D} ft ² ·hr·°F / Btu (m ² K / W)	R_o ft ² ·hr·°F / Btu (m ² K / W)	U_o Btu/ft ² ·hr·°F (W/m ² K)
R-15 (2.64)	R-18.2 (3.20)	R-11.3 (1.99)	0.088 (0.50)

Slab Linear Transmittance

Balcony Insulation Distance from wall ft (m)	R ft ² ·hr·°F / Btu (m ² K / W)	U Btu/ft ² ·hr·°F (W/m ² K)	ψ Btu/ft hr °F (W/m K)
0.00 (0.0)	R-6.5 (1.14)	0.155 (0.88)	0.445 (0.770)
0.66 (0.2)	R-7.0 (1.22)	0.144 (0.82)	0.402 (0.695)
1.31 (0.4)	R-7.1 (1.25)	0.141 (0.80)	0.395 (0.683)
2.62 (0.8)	R-7.1 (1.26)	0.139 (0.79)	0.393 (0.680)

Temperature Indices

D(ft)	0	0.66	1.31	2.62	
T_{i1}	0.58	0.61	0.62	0.62	Min T on sheathing, at slab, between studs
T_{i2}	0.84	0.84	0.85	0.85	Max T on sheathing, at studs, between girts

Detail 5.2.3

Exterior Insulated 3 5/8" x 1 5/8" Steel Stud (16" o.c.) Wall Assembly with Horizontal Z-Girts (24" o.c.) Supporting Metal Cladding – Intermediate Floor Intersection with Top & Under Side Insulation

Thermal Performance Indicators

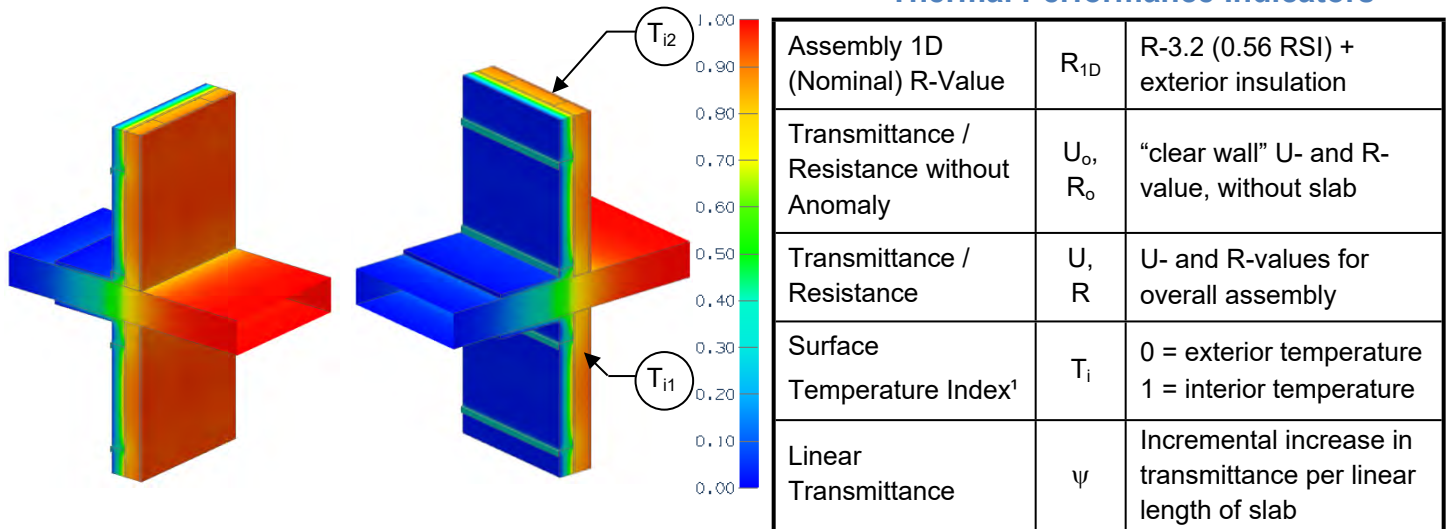

¹Assumptions and limitations for surface temperatures identified in ASHRAE 1365-RP

View from Interior View from Exterior

Nominal (1D) vs. Assembly Performance Indicators

Base Assembly – Wall

Exterior Insulation 1D R-Value (RSI)	R_{1D} ft ² ·hr·°F / Btu (m ² K / W)	R_o ft ² ·hr·°F / Btu (m ² K / W)	U_o Btu/ft ² ·hr·°F (W/m ² K)
R-15 (2.64)	R-18.2 (3.20)	R-11.3 (1.99)	0.088 (0.50)

Slab Linear Transmittance

Balcony Insulation Distance from wall ft (m)	R ft ² ·hr·°F / Btu (m ² K / W)	U Btu/ft ² ·hr·°F (W/m ² K)	ψ Btu/ft hr °F (W/m K)
0.00 (0.0)	R-6.5 (1.14)	0.155 (0.88)	0.445 (0.770)
0.66 (0.2)	R-7.2 (1.26)	0.140 (0.79)	0.342 (0.592)
1.31 (0.4)	R-7.5 (1.32)	0.134 (0.76)	0.306 (0.529)
2.62 (0.8)	R-7.6 (1.34)	0.131 (0.75)	0.287 (0.496)

Temperature Indices

D(ft)	0	0.66	1.31	2.62	
T_{i1}	0.58	0.66	0.69	0.70	Min T on sheathing, at slab, between studs
T_{i2}	0.84	0.85	0.85	0.85	Max T on sheathing, at studs, between girts

Detail 5.2.4

Exterior Insulated 3 5/8" x 1 5/8" Steel Stud (16" o.c.) Wall Assembly with Horizontal Z-girts (24" o.c.) Supporting Metal Cladding – Uninsulated Intermediate Floor Intersection with Uninsulated Curb

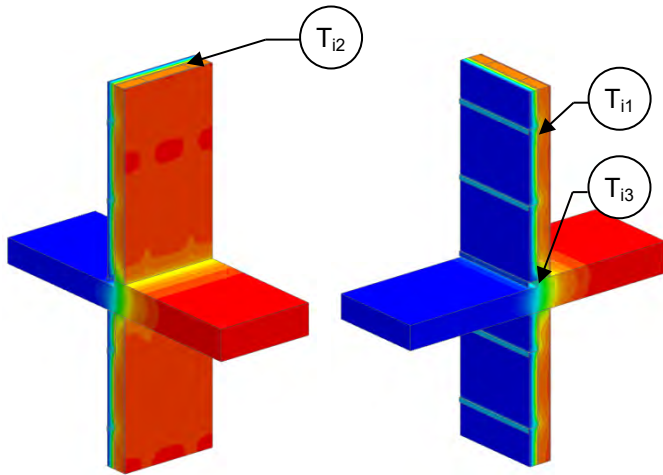

View from Interior

View from Exterior

Thermal Performance Indicators



Assembly 1D (Nominal) R-Value	R_{1D}	R-3.2 (0.56 RSI) + exterior insulation
Transmittance / Resistance without Anomaly	U_o, R_o	“clear wall” U- and R-value, without slab
Transmittance / Resistance	U, R	U- and R-values for overall assembly
Surface Temperature Index ¹	T_i	0 = exterior temperature 1 = interior temperature
Linear Transmittance	ψ	Incremental increase in transmittance per linear length of slab

¹Assumptions and limitations for surface temperatures identified in ASHRAE 1365-RP

Nominal (1D) vs. Assembly Performance Indicators

Exterior Insulation 1D R-Value (RSI)	R_{1D} ft ² ·hr·°F / Btu (m ² K / W)	R_o ft ² ·hr·°F / Btu (m ² K / W)	U_o Btu/ft ² ·hr ·°F (W/m ² K)	R ft ² ·hr·°F / Btu (m ² K / W)	U Btu/ft ² ·hr ·°F (W/m ² K)	ψ Btu/ft hr °F (W/m K)
R-15 (2.64)	R-18.2 (3.20)	R-11.3 (1.99)	0.088 (0.50)	R-6.8 (1.19)	0.148 (0.84)	0.584 (1.011)

Temperature Indices

T_{i1}	0.71	Min T on sheathing away from slab, between studs at girts
T_{i2}	0.86	Max T on sheathing away from slab, between girts at studs
T_{i3}	0.45	Min T on slab exposed to interior air, at sheathing between studs

Detail 5.2.5

Exterior and Interior Insulated 3 5/8" x 1 5/8" Steel Stud (16" o.c.) Wall Assembly with Horizontal Z-girts (24" o.c.) Supporting Metal Cladding and R-12 Batt Insulation in Stud Cavity – Uninsulated Intermediate Floor Intersection with Uninsulated Curb

Thermal Performance Indicators

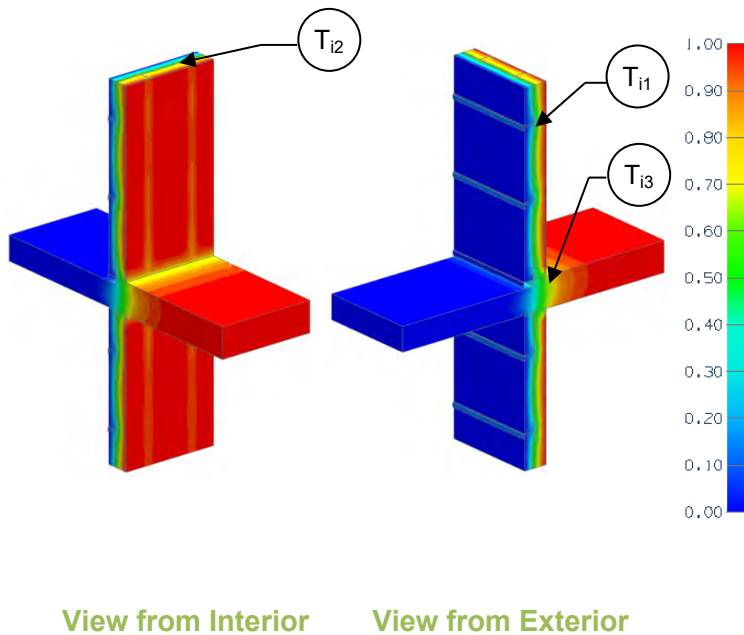

Assembly 1D (Nominal) R-Value	R_{1D}	R-14.2 (2.51 RSI) + exterior insulation
Transmittance / Resistance without Anomaly	U_o, R_o	“clear wall” U- and R-value, without slab
Transmittance / Resistance	U, R	U- and R-values for overall assembly
Surface Temperature Index ¹	T_i	0 = exterior temperature 1 = interior temperature
Linear Transmittance	ψ	Incremental increase in transmittance per linear length of slab

View from Interior

View from Exterior

¹Assumptions and limitations for surface temperatures identified in ASHRAE 1365-RP

Nominal (1D) vs. Assembly Performance Indicators

Exterior Insulation 1D R-Value (RSI)	R_{1D} ft ² ·hr·°F / Btu (m ² K / W)	R_o ft ² ·hr·°F / Btu (m ² K / W)	U_o Btu/ft ² ·hr ·°F (W/m ² K)	R ft ² ·hr·°F / Btu (m ² K / W)	U Btu/ft ² ·hr ·°F (W/m ² K)	ψ Btu/ft ·hr·°F (W/m K)
R-15 (2.64)	R-29.2 (5.15)	R-18.5 (3.25)	0.054 (0.31)	R-8.6 (1.51)	0.116 (0.66)	0.612 (1.059)

Temperature Indices

T_{i1}	0.35	Min T on sheathing away from slab, between studs at girts
T_{i2}	0.73	Max T on sheathing away from slab, between girts at studs
T_{i3}	0.64	Min T on slab exposed to interior air, at gypsum between studs

Detail 5.2.6

Exterior Insulated 3 5/8" x 1 5/8" Steel Stud (16" o.c.) Wall Assembly with Horizontal Z-girts (24" o.c.) Supporting Metal Cladding – Uninsulated Intermediate Floor Intersection with Insulated Curb

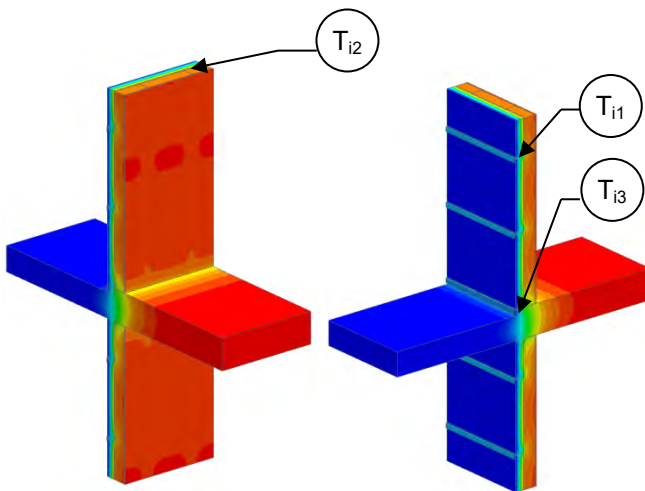

View from Interior

View from Exterior

Thermal Performance Indicators



Assembly 1D (Nominal) R-Value	R_{1D}	R-3.2 (0.56 RSI) + exterior insulation
Transmittance / Resistance without Anomaly	U_o, R_o	“clear wall” U- and R-value, without slab
Transmittance / Resistance	U, R	U- and R-values for overall assembly
Surface Temperature Index ¹	T_i	0 = exterior temperature 1 = interior temperature
Linear Transmittance	ψ	Incremental increase in transmittance per linear length of slab

¹Assumptions and limitations for surface temperatures identified in ASHRAE 1365-RP

Nominal (1D) vs. Assembly Performance Indicators

Exterior Insulation 1D R-Value (RSI)	R_{1D} ft ² ·hr·°F / Btu (m ² K / W)	R_o ft ² ·hr·°F / Btu (m ² K / W)	U_o Btu/ft ² ·hr ·°F (W/m ² K)	R ft ² ·hr·°F / Btu (m ² K / W)	U Btu/ft ² ·hr ·°F (W/m ² K)	ψ Btu/ft hr °F (W/m K)
R-15 (2.64)	R-18.2 (3.20)	R-11.3 (1.99)	0.088 (0.50)	R-7.3 (1.28)	0.138 (0.78)	0.485 (0.840)

Temperature Indices

T_{i1}	0.71	Min T on sheathing away from slab, between studs at girts
T_{i2}	0.86	Max T on sheathing away from slab, between girts at studs
T_{i3}	0.57	Min T on slab exposed to interior air, at sheathing between studs

Detail 5.2.7

Exterior and Interior Insulated 3 5/8" x 1 5/8" Steel Stud (16" o.c.) Wall Assembly with Horizontal Z-girts (24" o.c.) Supporting Metal Cladding and R-12 Batt Insulation in Stud Cavity – Uninsulated Intermediate Floor Intersection with Insulated Curb

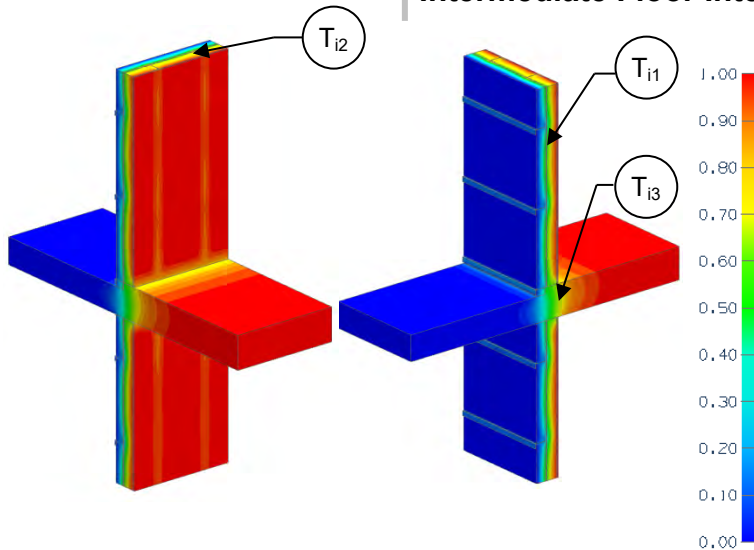

Thermal Performance Indicators

Assembly 1D (Nominal) R-Value	R_{1D}	R-14.2 (2.51 RSI) + exterior insulation
Transmittance / Resistance without Anomaly	U_o, R_o	“clear wall” U- and R-value, without slab
Transmittance / Resistance	U, R	U- and R-values for overall assembly
Surface Temperature Index ¹	T_i	0 = exterior temperature 1 = interior temperature
Linear Transmittance	ψ	Incremental increase in transmittance per linear length of slab

¹Assumptions and limitations for surface temperatures identified in ASHRAE 1365-RP

View from Interior

View from Exterior

Nominal (1D) vs. Assembly Performance Indicators

Exterior Insulation 1D R-Value (RSI)	R_{1D} ft ² ·hr·°F / Btu (m ² K / W)	R_o ft ² ·hr·°F / Btu (m ² K / W)	U_o Btu/ft ² ·hr·°F (W/m ² K)	R ft ² ·hr·°F / Btu (m ² K / W)	U Btu/ft ² ·hr·°F (W/m ² K)	ψ Btu/ft hr °F (W/m K)
R-15 (2.64)	R-29.2 (5.15)	R-18.5 (3.25)	0.054 (0.31)	R-9.3 (1.63)	0.108 (0.61)	0.528 (0.914)

Temperature Indices

T_{i1}	0.35	Min T on sheathing away from slab, between studs at girts
T_{i2}	0.73	Max T on sheathing away from slab, between girts at studs
T_{i3}	0.70	Min T on slab exposed to interior air, at gypsum between studs

Detail 5.2.8

Exterior and Interior Insulated 3 5/8" x 1 5/8" Steel Stud (16" o.c.) Wall Assembly with Vertical Z Girts (16" o.c.) Supporting Stucco Cladding and R-12 Batt Insulation in Stud Cavity – Uninsulated Intermediate Floor Intersection

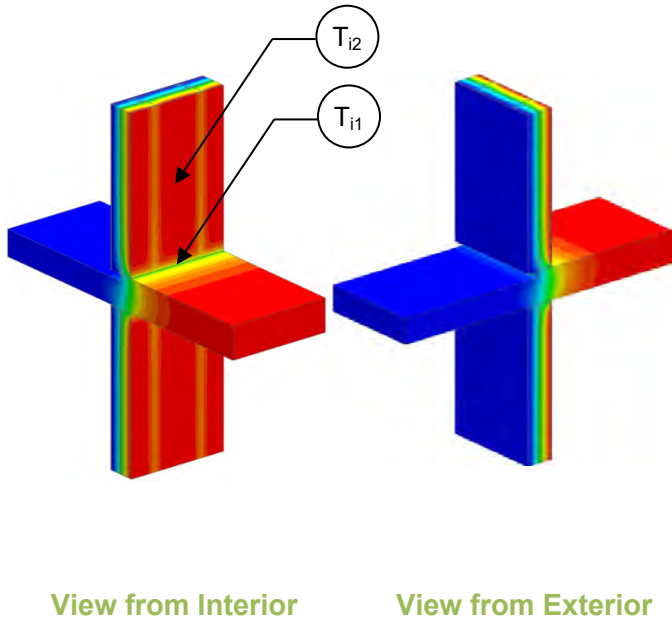

Thermal Performance Indicators

Assembly 1D (Nominal) R-Value	R_{1D}	R-14.5 (2.55 RSI) + exterior insulation
Transmittance / Resistance without Anomaly	U_o, R_o	“clear wall” U- and R-value, without slab
Transmittance / Resistance	U, R	U- and R-values for overall assembly
Surface Temperature Index ¹	T_i	0 = exterior temperature 1 = interior temperature
Linear Transmittance	ψ	Incremental increase in transmittance per linear length of slab

¹Assumptions and limitations for surface temperatures identified in ASHRAE 1365-RP

Nominal (1D) vs. Assembly Performance Indicators

Exterior Insulation 1D R-Value (RSI)	R_{1D} ft ² ·hr·°F / Btu (m ² K / W)	R_o ft ² ·hr·°F / Btu (m ² K / W)	U_o Btu/ft ² ·hr ·°F (W/m ² K)	R ft ² ·hr·°F / Btu (m ² K / W)	U Btu/ft ² ·hr ·°F (W/m ² K)	ψ Btu/ft ·hr·°F (W/m K)
R-10 (1.76)	R-24.5 (4.31)	R-13.0 (2.29)	0.077 (0.44)	R-6.6 (1.16)	0.152 (0.86)	0.664 (1.149)
R-15 (2.64)	R-29.5 (5.20)	R-14.1 (2.49)	0.071 (0.40)	R-6.9 (1.21)	0.146 (0.83)	0.665 (1.151)

Temperature Indices

	R10	R15	
T_{i1}	0.29	0.30	Min T on sheathing, along slab, between studs
T_{i2}	0.48	0.52	Max T on sheathing, at studs, between girts

Detail 5.2.9

Exterior Insulated 3 5/8" x 1 5/8" Steel Stud (16" o.c.) Drained EIFS Wall Assembly – Isokorb CM20 Thermally Broken Slab Projection without Concrete Curb

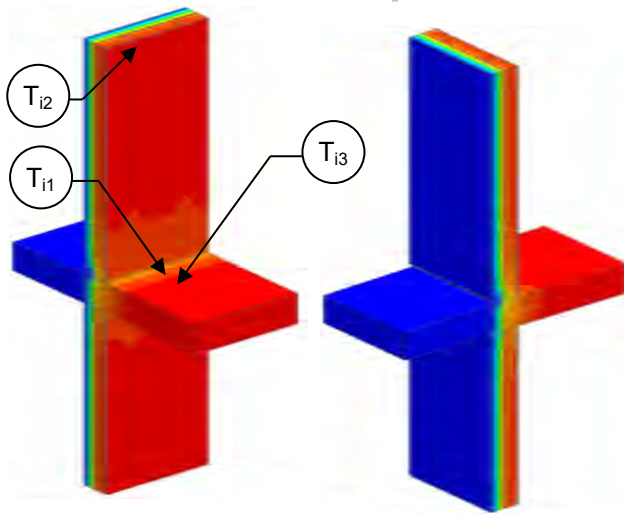

View from Interior

View from Exterior

Thermal Performance Indicators

Assembly 1D (Nominal) R-Value	R_{1D}	R-2.7 (0.47 RSI) + exterior insulation
Transmittance / Resistance without Anomaly	U_o, R_o	"clear wall" U- and R-value, without slab
Transmittance / Resistance	U, R	U and R-values for the assembly
Surface Temperature Index ¹	T_i	0 = exterior temperature 1 = interior temperature
Linear Transmittance	ψ	Incremental increase in transmittance per linear length of slab

¹Assumptions and limitations for surface temperatures identified in ASHRAE 1365-RP

Nominal (1D) vs. Assembly Performance Indicators

Exterior Insulation 1D R-Value (RSI)	R_{1D} ft ² ·hr·°F / Btu (m ² K / W)	R_o ft ² ·hr·°F / Btu (m ² K / W)	U_o Btu/ft ² ·hr ·°F (W/m ² K)	R ft ² ·hr·°F / Btu (m ² K / W)	U Btu/ft ² ·hr ·°F (W/m ² K)	ψ Btu/ft hr °F (W/m K)
R-15 (2.64)	R-17.7 (3.12)	R-17.4 (3.06)	0.057 (0.33)	R-12.1 (2.12)	0.083 (0.40)	0.253 (0.438)

Temperature Indices

T_{i1}	0.66	Min T on sheathing, along gap below EIFS at track, between studs
T_{i2}	0.89	Max T on sheathing, away from slab, at studs
T_{i3}	0.71	Min T on slab, along gypsum between studs, exposed to interior air

Detail 5.2.10

Exterior and Interior Insulated 3 5/8" x 1 5/8" Steel Stud (16" o.c.) Drained EIFS Wall Assembly with R-12 Batt Insulation in Stud Cavity – Isokorb CM20 Thermally Broken Slab Projection without Concrete Curb

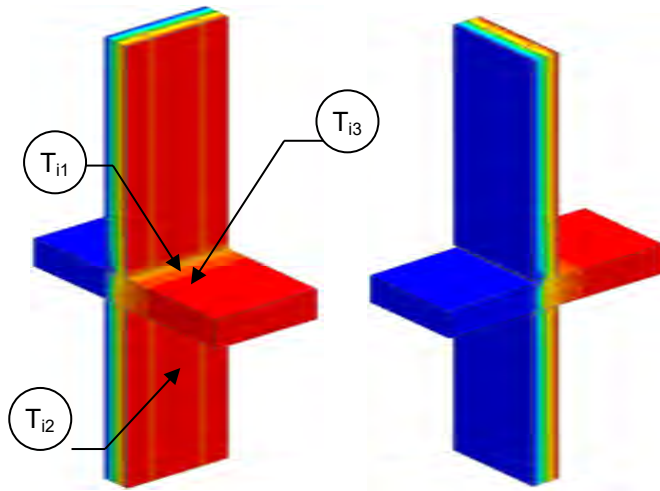

View from Interior

View from Exterior

Thermal Performance Indicators

Assembly 1D (Nominal) R-Value	R _{1D}	R-14.2 (2.51 RSI) + exterior insulation
Transmittance / Resistance without Anomaly	U _o , R _o	“clear wall” U- and R-value, without slab
Transmittance / Resistance	U, R	U and R-values for the assembly
Surface Temperature Index ¹	T _i	0 = exterior temperature 1 = interior temperature
Linear Transmittance	ψ	Incremental increase in transmittance per linear length of slab

¹Assumptions and limitations for surface temperatures identified in ASHRAE 1365-RP

Nominal (1D) vs. Assembly Performance Indicators

Exterior Insulation 1D R-Value (RSI)	R _{1D} ft ² ·hr·°F / Btu (m ² K / W)	R _o ft ² ·hr·°F / Btu (m ² K / W)	U _o Btu/ft ² ·hr ·°F (W/m ² K)	R ft ² ·hr·°F / Btu (m ² K / W)	U Btu/ft ² ·hr ·°F (W/m ² K)	ψ Btu/ft hr °F (W/m K)
R-15 (2.64)	R-29.2 (5.1)	R-24.0 (4.23)	0.042 (0.24)	R-15.0 (2.64)	0.067 (0.38)	0.246 (0.426)

Temperature Indices

T _{i1}	0.45	Min T on sheathing, along gap below EIFS at track, between studs
T _{i2}	0.77	Max T on sheathing, below slab, between studs
T _{i3}	0.68	Min T on slab, along gypsum between studs, exposed to interior air

Detail 5.2.11

Exterior and Interior Insulated 3 5/8" x 1 5/8" Steel Stud (16" o.c.) Wall Assembly with Horizontal Z-girts (24" o.c.) Supporting Metal Cladding and R-12 Batt Insulation in Stud Cavity – Isokorb CM20 Thermally Broken Slab Projection with Uninsulated Curb

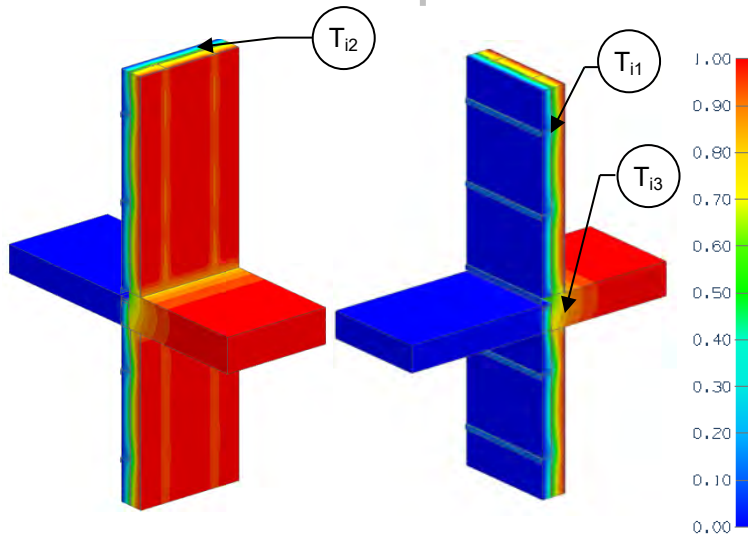

Thermal Performance Indicators

Assembly 1D (Nominal) R-Value	R_{1D}	R-14.2 (2.51 RSI) + exterior insulation
Transmittance / Resistance without Anomaly	U_o, R_o	“clear wall” U- and R-value, without slab
Transmittance / Resistance	U, R	U- and R-values for overall assembly
Surface Temperature Index ¹	T_i	0 = exterior temperature 1 = interior temperature
Linear Transmittance	ψ	Incremental increase in transmittance per linear length of slab

¹Assumptions and limitations for surface temperatures identified in ASHRAE 1365-RP

View from Interior

View from Exterior

Nominal (1D) vs. Assembly Performance Indicators

Exterior Insulation 1D R-Value (RSI)	R_{1D} ft ² ·hr·°F / Btu (m ² K / W)	R_o ft ² ·hr·°F / Btu (m ² K / W)	U_o Btu/ft ² ·hr ·°F (W/m ² K)	R ft ² ·hr·°F / Btu (m ² K / W)	U Btu/ft ² ·hr ·°F (W/m ² K)	ψ Btu/ft hr °F (W/m K)
R-15 (2.64)	R-29.2 (5.14)	R-18.5 (3.25)	0.054 (0.31)	R-11.6 (2.04)	0.087 (0.49)	0.319 (0.551)

Temperature Indices

T_{i1}	0.35	Min T on sheathing away from slab, between studs at girts
T_{i2}	0.73	Max T on sheathing away from slab, between girts at studs
T_{i3}	0.77	Min T on slab exposed to interior air, at gypsum between studs

Detail 5.2.12

Exterior Insulated 3 5/8" x 1 5/8" Steel Stud (16" o.c.) Wall Assembly with Horizontal Z-girts (24" o.c.) Supporting Metal Cladding – Isokorb CM20 Thermally Broken Slab Projection with Uninsulated Curb

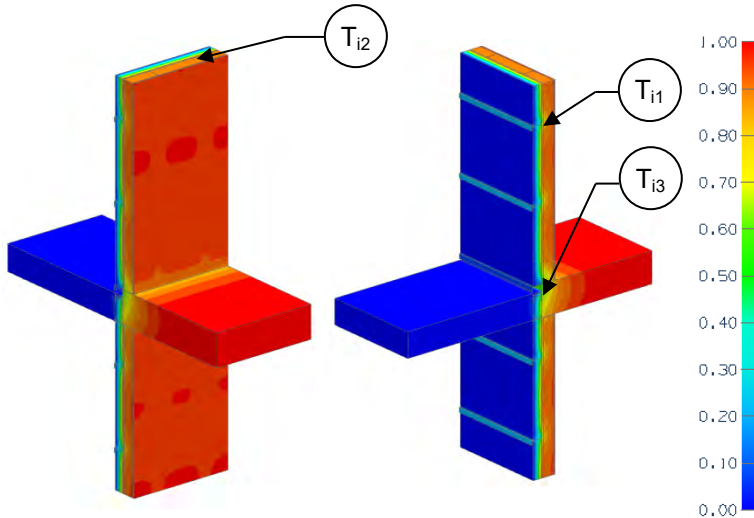

View from Interior

View from Exterior

Thermal Performance Indicators

Assembly 1D (Nominal) R-Value	R_{1D}	R-3.2 (0.56 RSI) + exterior insulation
Transmittance / Resistance without Anomaly	U_o , R_o	“clear wall” U- and R-value, without slab
Transmittance / Resistance	U, R	U- and R-values for overall assembly
Surface Temperature Index ¹	T_i	0 = exterior temperature 1 = interior temperature
Linear Transmittance	ψ	Incremental increase in transmittance per linear length of slab

¹Assumptions and limitations for surface temperatures identified in ASHRAE 1365-RP

Nominal (1D) vs. Assembly Performance Indicators

Exterior Insulation 1D R-Value (RSI)	R_{1D} ft ² ·hr·°F / Btu (m ² K / W)	R_o ft ² ·hr·°F / Btu (m ² K / W)	U_o Btu/ft ² ·hr ·°F (W/m ² K)	R ft ² ·hr·°F / Btu (m ² K / W)	U Btu/ft ² ·hr ·°F (W/m ² K)	ψ Btu/ft hr °F (W/m K)
R-15 (2.64)	R-18.2 (3.20)	R-11.3 (1.99)	0.088 (0.50)	R-8.7 (1.53)	0.115 (0.65)	0.261 (0.452)

Temperature Indices

T_{i1}	0.71	Min T on sheathing away from slab, between studs at girts
T_{i2}	0.86	Max T on sheathing away from slab, between girts at studs
T_{i3}	0.60	Min T on slab exposed to interior air, at sheathing between studs

Detail 5.2.13

Exterior Insulated 3 5/8" x 1 5/8" Steel Stud (16" o.c.) Wall Assembly with Horizontal Z-girts (24" o.c.) Supporting Metal Cladding – Isokorb CM20 Thermally Broken Slab Projection with Insulated Curb

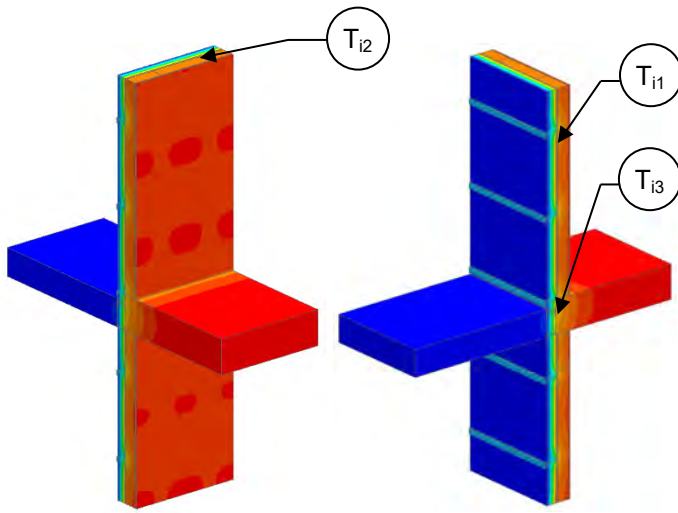

View from Interior

View from Exterior

Thermal Performance Indicators

Assembly 1D (Nominal) R-Value	R _{1D}	R-3.2 (0.56 RSI) + exterior insulation
Transmittance / Resistance without Anomaly	U _o , R _o	“clear wall” U- and R-value, without slab
Transmittance / Resistance	U, R	U- and R-values for overall assembly
Surface Temperature Index ¹	T _i	0 = exterior temperature 1 = interior temperature
Linear Transmittance	ψ	Incremental increase in transmittance per linear length of slab

¹Assumptions and limitations for surface temperatures identified in ASHRAE 1365-RP

Nominal (1D) vs. Assembly Performance Indicators

Exterior Insulation 1D R-Value (RSI)	R _{1D} ft ² ·hr·°F / Btu (m ² K / W)	R _o ft ² ·hr·°F / Btu (m ² K / W)	U _o Btu/ft ² ·hr·°F (W/m ² K)	R ft ² ·hr·°F / Btu (m ² K / W)	U Btu/ft ² ·hr·°F (W/m ² K)	ψ Btu/ft hr °F (W/m K)
R-15 (2.64)	R-18.2 (3.20)	R-11.3 (1.99)	0.088 (0.50)	R-10.0 (1.76)	0.100 (0.57)	0.117 (0.203)

Temperature Indices

T ₁₁	0.71	Min T on sheathing away from slab, between studs at girts
T ₁₂	0.86	Max T on sheathing away from slab, between girts at studs
T ₁₃	0.77	Min T on slab exposed to interior air, at sheathing between studs

Detail 5.2.14

Exterior and Interior Insulated 3 5/8" x 1 5/8" Steel Stud (16" o.c.) Wall Assembly with Horizontal Z-girts (24" o.c.) Supporting Metal Cladding and R-12 Batt Insulation in Stud Cavity – Isokorb CM20 Thermally Broken Slab Projection with Insulated Curb

Thermal Performance Indicators

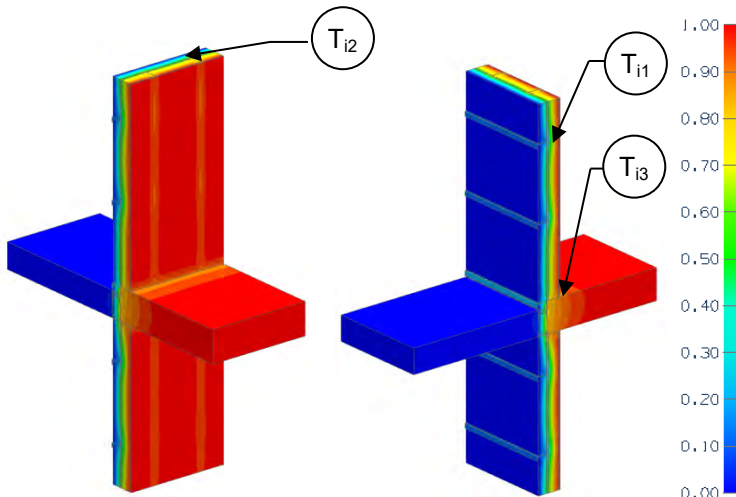

Assembly 1D (Nominal) R-Value	R_{1D}	R-14.2 (2.51 RSI) + exterior insulation
Transmittance / Resistance without Anomaly	U_o, R_o	“clear wall” U- and R-value, without slab
Transmittance / Resistance	U, R	U- and R-values for overall assembly
Surface Temperature Index ¹	T_i	0 = exterior temperature 1 = interior temperature
Linear Transmittance	ψ	Incremental increase in transmittance per linear length of slab

¹Assumptions and limitations for surface temperatures identified in ASHRAE 1365-RP

View from Interior

View from Exterior

Nominal (1D) vs. Assembly Performance Indicators

Exterior Insulation 1D R-Value (RSI)	R_{1D} ft ² ·hr·°F / Btu (m ² K / W)	R_o ft ² ·hr·°F / Btu (m ² K / W)	U_o Btu/ft ² ·hr ·°F (W/m ² K)	R ft ² ·hr·°F / Btu (m ² K / W)	U Btu/ft ² ·hr ·°F (W/m ² K)	ψ Btu/ft hr °F (W/m K)
R-15 (2.64)	R-29.2 (5.14)	R-18.5 (3.25)	0.054 (0.31)	R-13.6 (2.40)	0.073 (0.42)	0.189 (0.327)

Temperature Indices

T_{i1}	0.35	Min T on sheathing away from slab, between studs at girts
T_{i2}	0.73	Max T on sheathing away from slab, between girts at studs
T_{i3}	0.85	Min T on slab exposed to interior air, at gypsum between studs

Detail 5.2.15

Exterior Insulated 3 5/8" x 1 5/8" Steel Stud (16" o.c.) Drained EIFS Wall Assembly – Intermediate Floor Intersection

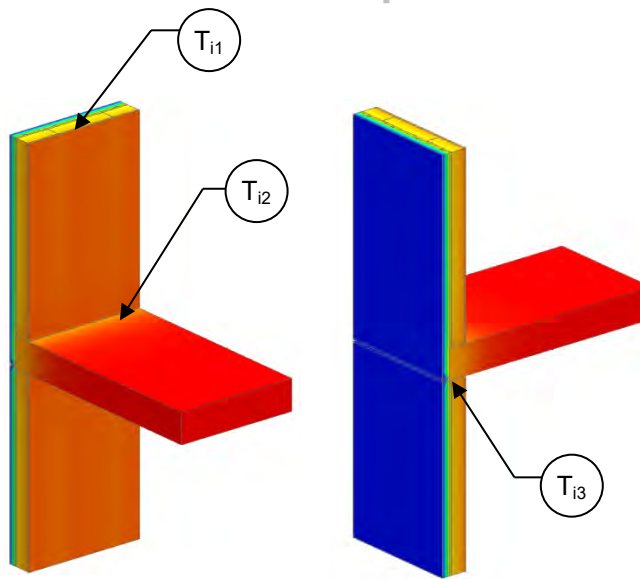

Thermal Performance Indicators

Assembly 1D (Nominal) R-Value	R_{1D}	R-2.7 (0.47 RSI) + exterior insulation
Transmittance / Resistance without Anomaly	U_o, R_o	"clear wall" U- and R-value without slab
Transmittance / Resistance	U, R	U- and R-values for overall assembly
Surface Temperature Index ¹	T_i	0 = exterior temperature 1 = interior temperature
Linear Transmittance	ψ	Incremental increase in transmittance per linear length of slab

¹Assumptions and limitations for surface temperatures identified in ASHRAE 1365-RP

View from Interior

View from Exterior

Nominal (1D) vs. Assembly Performance Indicators

Exterior Insulation 1D R-Value (RSI)	R_{1D} ft ² ·hr·°F / Btu (m ² K / W)	R_o ft ² ·hr·°F / Btu (m ² K / W)	U_o Btu/ft ² ·hr·°F (W/m ² K)	R ft ² ·hr·°F / Btu (m ² K / W)	U Btu/ft ² ·hr·°F (W/m ² K)	ψ Btu/ft·hr·°F (W/m K)
R-7.5 (1.32)	R-10.2 (1.80)	R-10.0 (1.76)	0.100 (0.57)	R-9.7 (1.70)	0.104 (0.59)	0.032 (0.055)
R-11.3 (1.98)	R-13.9 (2.46)	R-13.7 (2.41)	0.073 (0.41)	R-13.3 (2.35)	0.075 (0.43)	0.018 (0.032)
R-15 (2.64)	R-17.7 (3.12)	R-17.4 (3.06)	0.057 (0.33)	R-17.0 (2.99)	0.059 (0.33)	0.012 (0.022)

Temperature Indices

	R7.5	R11.3	R15	
T_{i1}	0.80	0.85	0.88	Min T on sheathing, between studs
T_{i2}	0.86	0.90	0.93	Max T on sheathing, along steel track at slab
T_{i3}	0.91	0.94	0.95	Min T on slab, at edge interior drywall, exposed to interior air

Detail 5.2.16

Exterior and Interior Insulated 3 5/8" x 1 5/8" Steel Stud (16" o.c.) Drained EIFS Wall Assembly with R-12 Batt Insulation in Stud Cavity – Intermediate Floor Intersection

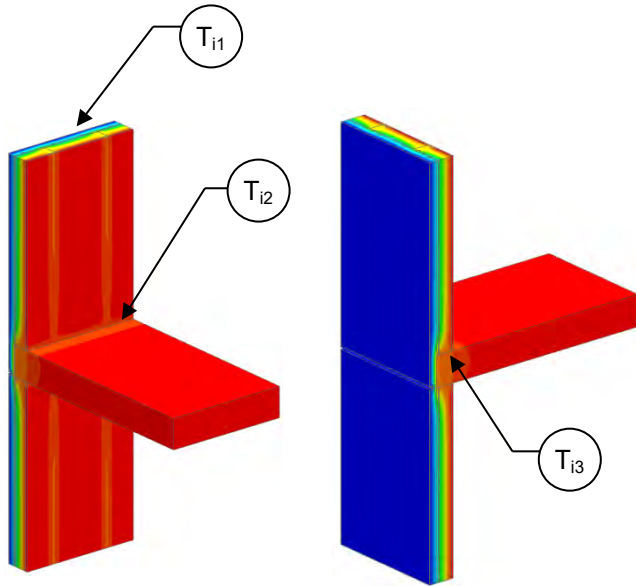

Thermal Performance Indicators

Assembly 1D (Nominal) R-Value	R_{1D}	R-14.2 (2.51 RSI) + exterior insulation
Transmittance / Resistance without Anomaly	U_o, R_o	"clear wall" U- and R-value without slab
Transmittance / Resistance	U, R	U- and R-values for overall assembly
Surface Temperature Index ¹	T_i	0 = exterior temperature 1 = interior temperature
Linear Transmittance	ψ	Incremental increase in transmittance per linear length of slab

¹Assumptions and limitations for surface temperatures identified in ASHRAE 1365-RP

View from Interior

View from Exterior

Nominal (1D) vs. Assembly Performance Indicators

Exterior Insulation 1D R-Value (RSI)	R_{1D} ft ² ·hr·°F / Btu (m ² K / W)	R_o ft ² ·hr·°F / Btu (m ² K / W)	U_o Btu/ft ² ·hr ·°F (W/m ² K)	R ft ² ·hr·°F / Btu (m ² K / W)	U Btu/ft ² ·hr ·°F (W/m ² K)	ψ Btu/ft ·hr ·°F (W/m K)
R-7.5 (1.32)	R-21.7 (3.83)	R-16.6 (2.93)	0.060 (0.34)	R-14.5 (2.55)	0.069 (0.39)	0.076 (0.132)
R-15 (2.64)	R-29.2 (5.15)	R-24.0 (4.23)	0.042 (0.24)	R-22.0 (3.88)	0.045 (0.26)	0.032 (0.056)

Temperature Indices

	R7.5	R15	
T_{i1}	0.41	0.58	Min T on sheathing, between studs
T_{i2}	0.85	0.91	Max T on sheathing, along steel track at slab
T_{i3}	0.90	0.94	Min T on slab, at edge interior drywall, exposed to interior air

Detail 5.2.17

Exterior Insulated 3 5/8" x 1 5/8" Steel Stud (16" o.c.) Wall Assembly with Thermally Broken ISO Clip System Supporting Vertical Sub-girts – Intermediate Concrete Floor Intersection

Thermal Performance Indicators

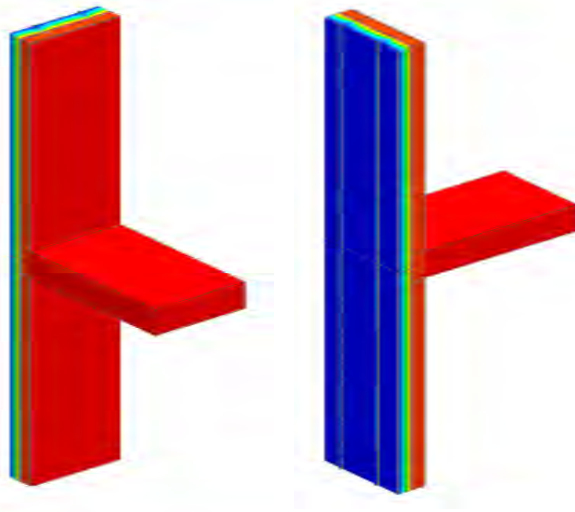

Assembly 1D (Nominal) R-Value	R_{1D}	R-3.3 (0.58 RSI) + exterior insulation
Transmittance / Resistance without Anomaly	U_o, R_o	“clear wall” U- and R-value without slab
Transmittance / Resistance	U, R	U- and R-values for overall assembly
Linear Transmittance	ψ	Incremental increase in transmittance per linear length of slab

View from Interior

View from Exterior

Nominal (1D) vs. Assembly Performance Indicators

Exterior Insulation 1D R-Value (RSI)	R_{1D} ft ² ·hr·°F / Btu (m ² K / W)	R_o ft ² ·hr·°F / Btu (m ² K / W)	U_o Btu/ft ² ·hr ·°F (W/m ² K)	R ft ² ·hr·°F / Btu (m ² K / W)	U Btu/ft ² ·hr ·°F (W/m ² K)	ψ Btu/ft ·hr ·°F (W/m K)
16.8 (2.96)	20.1 (3.54)	R-15.1 (2.66)	0.066 (0.376)	14.7 (2.59)	0.068 (0.388)	0.027 (0.046)
21.0 (3.70)	24.2 (4.28)	R-16.7 (2.94)	0.060 (0.340)	16.4 (2.89)	0.061 (0.347)	0.017 (0.029)
25.2 (4.44)	28.5 (5.02)	R-18.0 (3.18)	0.055 (0.315)	17.9 (3.14)	0.056 (0.319)	0.009 (0.016)

Detail 5.2.18

Exterior Insulated 3 5/8" x 1 5/8" Steel Stud (16" o.c.) Wall Assembly with Thermally Broken ISO Clip System Supporting Horizontal Sub-girts – Intermediate Concrete Floor Intersection

Thermal Performance Indicators

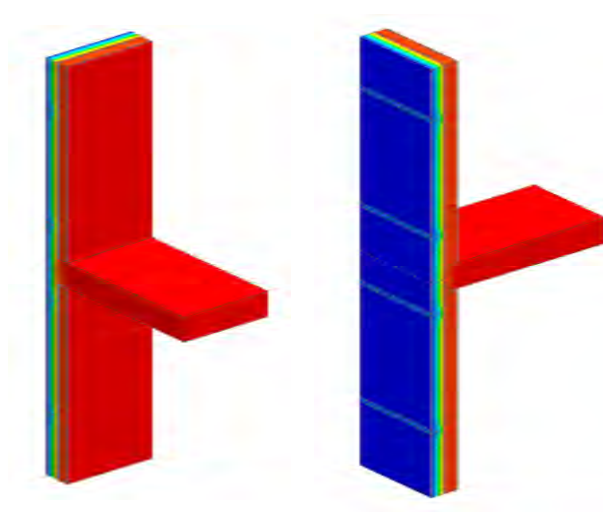

Assembly 1D (Nominal) R-Value	R_{1D}	R-3.3 (0.58 RSI) + exterior insulation
Transmittance / Resistance without Anomaly	U_o, R_o	“clear wall” U- and R-value without slab
Transmittance / Resistance	U, R	U- and R-values for overall assembly
Linear Transmittance	ψ	Incremental increase in transmittance per linear length of slab

View from Interior

View from Exterior

Nominal (1D) vs. Assembly Performance Indicators

Exterior Insulation 1D R-Value (RSI)	R_{1D} ft ² ·hr·°F / Btu (m ² K / W)	R_o ft ² ·hr·°F / Btu (m ² K / W)	U_o Btu/ft ² ·hr ·°F (W/m ² K)	R ft ² ·hr·°F / Btu (m ² K / W)	U Btu/ft ·hr ·°F (W/m ² K)	ψ Btu/ft ·hr ·°F (W/m K)
16.8 (2.96)	20.1 (3.54)	R-16.3 (2.87)	0.061 (0.349)	15.4 (2.71)	0.065 (0.369)	0.027 (0.046)
21.0 (3.70)	24.3 (4.28)	R-18.6 (3.28)	0.054 (0.305)	17.5 (3.09)	0.057 (0.322)	0.017 (0.029)
25.2 (4.44)	28.5 (5.02)	R-20.7 (3.65)	0.048 (0.274)	19.6 (3.45)	0.051 (0.289)	0.009 (0.016)

Detail 5.2.19

Exterior and Interior Insulated 3 5/8" x 1 5/8" Steel Stud (16" o.c.) Wall Assembly with Vertical Z-girts (16" o.c.) Supporting Stucco Cladding and R-12 Batt Insulation in Stud Cavity – Steel Framed Floor with Cross Cavity Flashing

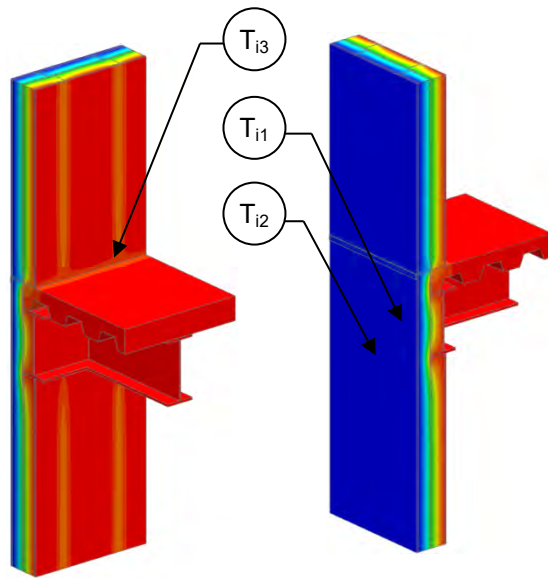

Thermal Performance Indicators

Assembly 1D (Nominal) R-Value	R _{1D}	R-14.5 (2.55 RSI) + exterior insulation
Transmittance / Resistance without Anomaly	U _o , R _o	"clear wall" U- and R-value, without slab
Transmittance / Resistance	U, R	U- and R-values for overall assembly
Surface Temperature Index ¹	T _i	0 = exterior temperature 1 = interior temperature
Linear Transmittance	ψ	Incremental increase in transmittance per linear length steel framed floor

¹Assumptions and limitations for surface temperatures identified in ASHRAE 1365-RP

View from Interior

View from Exterior

Nominal (1D) vs. Assembly Performance Indicators

Exterior Insulation 1D R-Value (RSI)	R _{1D} ft ² ·hr·°F / Btu (m ² K / W)	R _o ft ² ·hr·°F / Btu (m ² K / W)	U _o Btu/ft ² ·hr ·°F (W/m ² K)	R ft ² ·hr·°F / Btu (m ² K / W)	U Btu/ft ² ·hr ·°F (W/m ² K)	ψ Btu/ft ·hr·°F (W/m K)
R-10 (1.76)	R-24.5 (4.31)	R-13.0 (2.29)	0.077 (0.44)	R-10.5 (1.85)	0.095 (0.54)	0.178 (0.309)
R-15 (2.64)	R-29.5 (5.20)	R-14.1 (2.49)	0.071 (0.40)	R-11.5 (2.03)	0.087 (0.49)	0.159 (0.275)

Temperature Indices

	R10	R15	
T _{i1}	0.35	0.36	Min T on sheathing, mid height of cavity behind I-beam, aligned with external girts
T _{i2}	0.90	0.92	Max T on sheathing, bottom of cavity behind I- beam, beside lower wall track, centered between external girts
T _{i3}	0.08	0.86	Min T on floor slab, at gypsum and studs, along upper track

Detail 5.2.20

Exterior Insulated 3 5/8" x 1 5/8" Steel Stud (16" o.c.) Wall Assembly with Fiberglass Spacer and Through Insulation Fasteners Supporting Cladding – Insulated Intermediate Floor Intersection

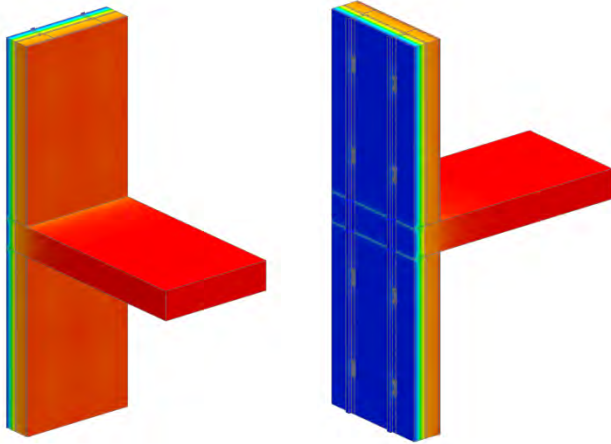

Thermal Performance Indicators

Assembly 1D (Nominal) R-Value	R_{1D}	R-3.3 (0.58 RSI) + exterior insulation
Transmittance / Resistance without Anomaly	U_o, R_o	“clear wall” U- and R-value
Transmittance / Resistance	U, R	U- and R-values for overall assembly
Linear Transmittance	ψ	Incremental increase in transmittance per linear length steel framed floor

View from Interior

View from Exterior

Nominal (1D) vs. Assembly Performance Indicators

Exterior Insulation 1D R-value (RSI)	R_{1D} ft ² ·hr·°F / Btu (m ² K / W)	R_o ft ² ·hr·°F / Btu (m ² K / W)	U_o Btu/ft ² ·hr ·°F (W/m ² K)	R ft ² ·hr·°F / Btu (m ² K / W)	U Btu/ft ² ·hr ·°F (W/m ² K)	ψ Btu/ft ·hr·°F (W/m K)
R-14.7 (2.59)	R-18.0 (3.17)	R-15.0 (2.65)	0.066 (0.38)	R-14.9 (2.63)	0.070 (0.38)	0.035 (0.060)

Detail 5.2.21

Exterior Insulated 3 5/8" x 1 5/8" Steel Stud (16" o.c.) Wall Assembly with Thermally Isolated Aluminum Clip Horizontal Sub-girt System Supporting Cladding – Intermediate Floor Intersection

Thermal Performance Indicators

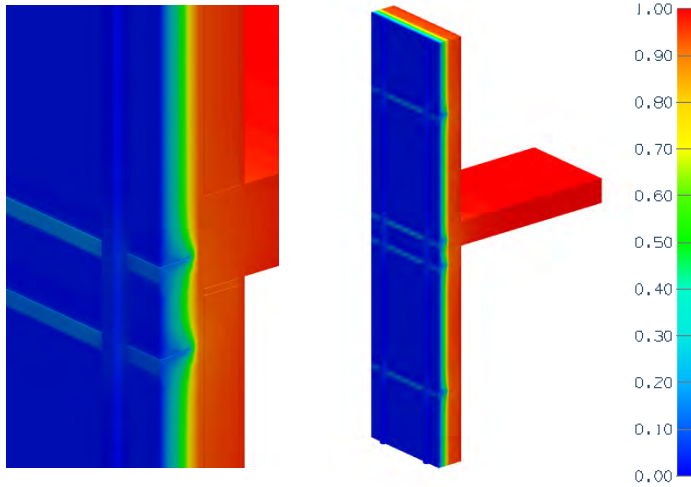

Assembly 1D (Nominal) R-Value	R_{1D}	R-3.3 (0.58 RSI) + exterior insulation
Transmittance / Resistance	U, R	U- and R-values for overall assembly
Linear Transmittance	ψ	Incremental increase in transmittance per linear length of slab

View of Intersection

View from Exterior

Nominal (1D) vs. Assembly Performance Indicators

Assembly – Exterior Insulated Assembly

Clip Type	Exterior Insulation 1D R-Value (RSI)	R_{1D} ft ² ·hr·°F / Btu (m ² K / W)	34" Vertical Clip Spacing		41" Vertical Clip Spacing		48" Vertical Clip Spacing		ψ Btu/ft hr °F (W/m K)
			R ft ² ·hr·°F / Btu (m ² K / W)	U Btu/ft ² ·hr ·°F (W/m ² K)	R ft ² ·hr·°F / Btu (m ² K / W)	U Btu/ft ² ·hr ·°F (W/m ² K)	R ft ² ·hr·°F / Btu (m ² K / W)	U Btu/ft ² ·hr ·°F (W/m ² K)	
T100	R-16.8 (2.96)	R-21.1 (3.54)	R-15.6 (2.75)	0.064 (0.364)	R-16.1 (2.84)	0.062 (0.354)	R-16.4 (2.89)	0.061 (0.346)	0.029 (0.05)
T125	R-21.0 (3.70)	R-24.3 (5.28)	R-18.2 (3.20)	0.055 (0.312)	R-18.9 (3.32)	0.053 (0.303)	R-19.2 (3.39)	0.052 (0.297)	0.041 (0.07)
T150	R-25.2 (4.44)	R-28.5 (5.02)	R-20.8 (3.67)	0.048 (0.275)	R-21.3 (3.75)	0.047 (0.266)	R-21.7 (3.83)	0.046 (0.259)	0.041 (0.07)

Detail 5.2.22

Exterior Insulated 3 5/8" x 1 5/8" Steel Stud (16" o.c.) Wall Assembly with TAC Fiber Reinforced Plastic Girts Supporting Cladding – Intermediate Floor Intersection

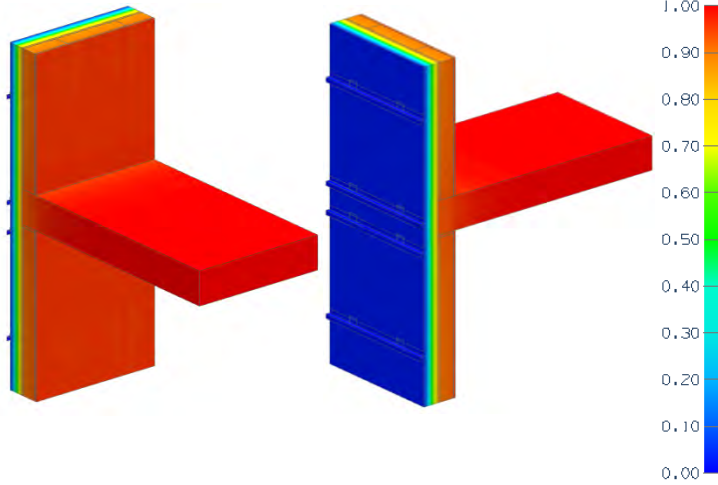

View from Interior

View from Exterior

Thermal Performance Indicators

Assembly 1D (Nominal) R-Value	R_{1D}	R-3.3 (0.58 RSI) + exterior insulation
Transmittance / Resistance	U, R	U- and R-values for overall assembly
Linear Transmittance	ψ	Incremental increase in transmittance per linear length of slab

Nominal (1D) vs. Assembly Performance Indicators

Without Fiberglass Batt Insulation in Stud Cavity

Exterior Insulation 1D R-Value (RSI)	R_{1D} ft ² ·hr·°F / Btu (m ² K / W)	24" Vertical Clip Spacing		36" Vertical Clip Spacing		48" Vertical Clip Spacing		ψ Btu/ft hr °F (W/m K)
		R ft ² ·hr·°F / Btu (m ² K / W)	U Btu/ft ² ·hr ·°F (W/m ² K)	R ft ² ·hr·°F / Btu (m ² K / W)	U Btu/ft ² ·hr ·°F (W/m ² K)	R ft ² ·hr·°F / Btu (m ² K / W)	U Btu/ft ² ·hr ·°F (W/m ² K)	
R-12.6 (2.22)	R-15.8 (2.78)	R-14.7 (2.56)	0.068 (0.39)	R-14.9 (2.63)	0.067 (0.38)	R-14.9 (2.63)	0.067 (0.38)	0.017 (0.029)
R-16.8 (3.00)	R-20.0 (3.52)	R-18.9 (3.33)	0.053 (0.30)	R-18.9 (3.33)	0.053 (0.30)	R-19.2 (3.33)	0.052 (0.30)	0.009 (0.016)
R-21.0 (3.70)	R-24.4 (4.30)	R-22.7 (4.00)	0.044 (0.25)	R-23.2 (4.00)	0.043 (0.25)	R-23.2 (4.00)	0.043 (0.25)	0.008 (0.014)
R-25.2 (4.40)	R-28.4 (5.00)	R-27.0 (4.76)	0.037 (0.21)	R-27.0 (4.76)	0.037 (0.21)	R-27.0 (4.76)	0.037 (0.21)	0.008 (0.014)

Detail 5.2.23

Exterior Insulated 3 5/8" x 1 5/8" Steel Stud (16" o.c.) Wall Assembly with Thermally Broken Aluminum Clip Rail System (24" o.c.) Supporting Cladding – Intermediate Floor Intersection

Thermal Performance Indicators

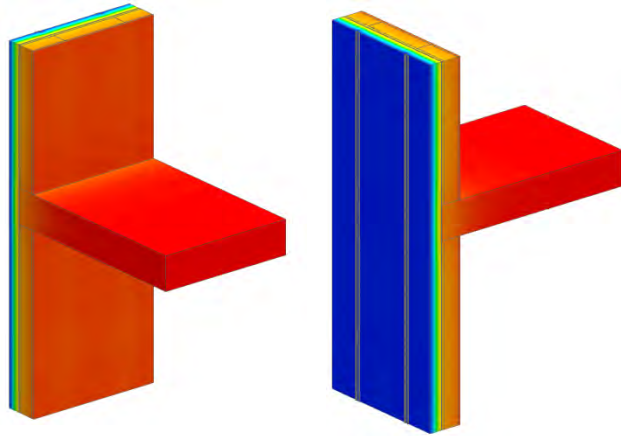

Assembly 1D (Nominal) R-Value	R_{1D}	R-3.3 (0.58 RSI) + exterior insulation
Transmittance / Resistance	U, R	U- and R-values for overall assembly
Linear Transmittance	ψ	Incremental increase in transmittance per linear length of slab

View from Interior

View from Exterior

Nominal (1D) vs. Assembly Performance Indicators

Assembly – Without Fiberglass Batt Insulation in Stud Cavity

Exterior Insulation 1D R-Value (RSI)	R_{1D} ft ² ·hr·°F / Btu (m ² K / W)	24" Vertical Clip Spacing		30" Vertical Clip Spacing		36" Vertical Clip Spacing		42" Vertical Clip Spacing		ψ Btu/ft hr °F (W/m K)
		R ft ² ·hr·°F / Btu (m ² K / W)	U Btu/ft ² ·hr ·°F (W/m ² K)	R ft ² ·hr·°F / Btu (m ² K / W)	U Btu/ft ² ·hr ·°F (W/m ² K)	R ft ² ·hr·°F / Btu (m ² K / W)	U Btu/ft ² ·hr ·°F (W/m ² K)	R ft ² ·hr·°F / Btu (m ² K / W)	U Btu/ft ² ·hr ·°F (W/m ² K)	
R-12.6 (2.22)	R-15.8 (2.78)	R-13.0 (2.27)	0.077 (0.44)	R-13.2 (2.33)	0.076 (0.43)	R-13.5 (2.38)	0.074 (0.42)	R-13.7 (2.41)	0.073 (0.42)	0.042 (0.073)
R-16.8 (3.00)	R-20.0 (3.52)	R-15.4 (2.71)	0.065 (0.37)	R-15.9 (2.81)	0.063 (0.36)	R-16.4 (2.89)	0.061 (0.35)	R-16.7 (2.95)	0.060 (0.34)	0.041 (0.071)
R-21.0 (3.70)	R-24.4 (4.30)	R-17.5 (3.10)	0.057 (0.32)	R-18.5 (3.25)	0.054 (0.31)	R-18.9 (3.36)	0.053 (0.30)	R-19.6 (3.44)	0.051 (0.29)	0.040 (0.068)
R-25.2 (4.40)	R-28.4 (5.00)	R-19.2 (3.41)	0.052 (0.29)	R-20.4 (3.60)	0.049 (0.28)	R-21.3 (3.75)	0.047 (0.27)	R-21.7 (3.86)	0.046 (0.26)	0.042 (0.072)

Detail 5.2.24

Exterior and Interior Insulated 3 5/8" x 1 5/8" Steel Stud (16" o.c) Wall Assembly with Horizontal Z-Girts (24" o.c.) Supporting Metal Cladding and R-12 Batt Insulation in Stud Cavity – Structural Steel Framed Floor Intersection

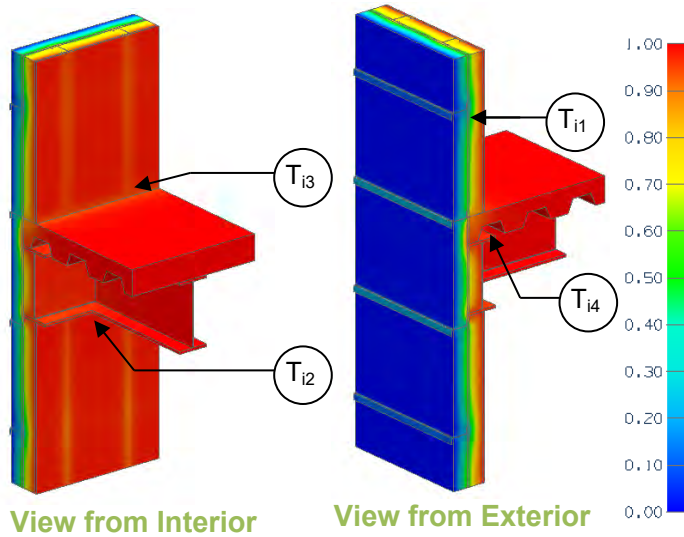

Thermal Performance Indicators

Assembly 1D (Nominal) R-Value	R_{1D}	R- 14.2 (2.50 RSI) + Exterior Insulation
Transmittance / Resistance without Anomaly	U_o, R_o	"clear wall" U- and R-value, without slab and I-Beam
Transmittance / Resistance	U, R	U- and R-values for overall assembly
Surface Temperature Index ¹	T_i	0 = exterior temperature 1 = interior temperature
Linear Transmittance	ψ	Incremental increase in transmittance per linear length of the slab and I-Beam

¹Assumptions and limitations for surface temperatures identified in ASHRAE 1365-RP

Nominal (1D) vs. Assembly Performance Indicators

Exterior Insulation 1D R-Value (RSI)	R_{1D} ft ² ·hr·°F / Btu (m ² K / W)	R_o ft ² ·hr·°F / Btu (m ² K / W)	U_o Btu/ft ² ·hr ·°F (W/m ² K)	R ft ² ·hr·°F / Btu (m ² K / W)	U Btu/ft ² ·hr ·°F (W/m ² K)	ψ Btu/ft hr °F (W/m K)
R-0 (0)	R-14.2 (2.50)	R-9.2 (1.62)	0.109 (0.62)	R-5.9 (1.04)	0.170 (0.96)	0.487 (0.842)
R-5 (0.88)	R-19.2 (3.38)	R-13.4 (2.36)	0.075 (0.42)	R-10.3 (1.82)	0.097 (0.55)	0.177 (0.306)
R-10 (1.76)	R-24.2 (4.26)	R-16.3 (2.87)	0.061 (0.35)	R-13.1 (2.30)	0.077 (0.44)	0.121 (0.210)
R-15 (2.64)	R-29.2 (5.14)	R-18.5 (3.25)	0.054 (0.31)	R-15.2 (2.68)	0.066 (0.37)	0.093 (0.162)
R-20 (3.52)	R-34.2 (6.02)	R-20.5 (3.61)	0.049 (0.28)	R-17.1 (3.00)	0.059 (0.33)	0.079 (0.137)
R-25 (4.40)	R-39.2 (6.90)	R-22.1 (3.90)	0.045 (0.26)	R-18.7 (3.28)	0.054 (0.30)	0.067 (0.117)

Temperature Indices

	R5	R10	R15	R20	R25	
T_{i1}	0.21	0.28	0.33	0.36	0.39	Min T on sheathing, along girt between studs, away from slab
T_{i2}	0.89	0.92	0.94	0.95	0.95	Max T on sheathing, at I-Beam intersection
T_{i3}	0.89	0.91	0.93	0.93	0.94	Min T on floor, at gypsum and steel studs
T_{i4}	0.94	0.96	0.96	0.97	0.97	Min T on ceiling, at corrugated sheet, away from I-Beam

Detail 5.2.25

Interior Insulated 3 5/8" x 1 5/8" Steel Stud (16" o.c) Wall Assembly with Horizontal Z-Girts (24" o.c.) Supporting Metal Cladding and R-12 Batt Insulation in Stud Cavity – Structural Steel Framed Floor Intersection

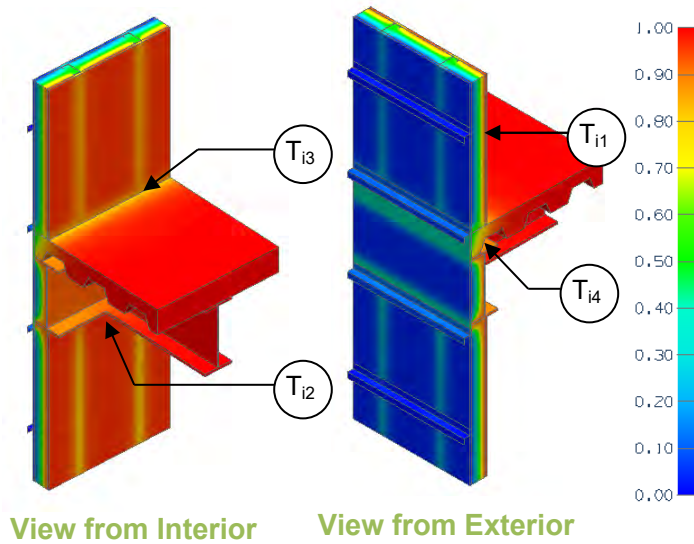

Thermal Performance Indicators

Assembly 1D (Nominal) R-Value	R_{1D}	R- 14.2 (2.50 RSI) + exterior insulation
Transmittance / Resistance without Anomaly	U_o, R_o	"clear wall" U- and R-value, without slab and I-Beam
Transmittance / Resistance	U, R	U- and R-values for overall assembly
Surface Temperature Index ¹	T_i	0 = exterior temperature 1 = interior temperature
Linear Transmittance	ψ	Incremental increase in transmittance per linear length of the slab and I-Beam

¹Assumptions and limitations for surface temperatures identified in ASHRAE 1365-RP

Nominal (1D) vs. Assembly Performance Indicators

Exterior Insulation 1D R-Value (RSI)	R_{1D} ft ² ·hr·°F / Btu (m ² K / W)	R_o ft ² ·hr·°F / Btu (m ² K / W)	U_o Btu/ft ² ·hr ·°F (W/m ² K)	R ft ² ·hr·°F / Btu (m ² K / W)	U Btu/ft ² ·hr ·°F (W/m ² K)	ψ Btu/ft hr °F (W/m K)
R-0 (0)	R-14.2 (2.50)	R-9.2 (1.62)	0.109 (0.62)	5.9 (1.04)	0.170 (0.96)	0.487 (0.842)

Temperature Indices

T_{i1}	0.07	Min T on sheathing, along girt between studs, away from slab
T_{i2}	0.71	Max T on sheathing, at I-Beam intersection
T_{i3}	0.79	Min T on floor, at gypsum and steel studs
T_{i4}	0.81	Min T on ceiling, at corrugated steel, away from I-Beam

Detail 5.2.26

Exterior and Interior Insulated Wall Assembly with Shelf Angle & Brick Ties Supporting Brick Veneer and R-12 Batt Insulation in Stud Cavity – Intermediate Floor Intersection

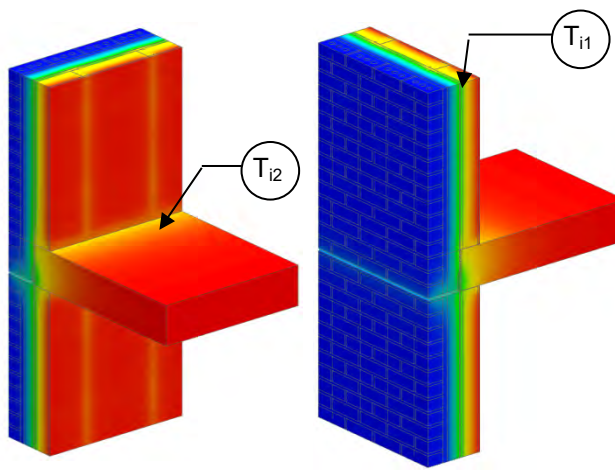

View from Interior

View from Exterior

Thermal Performance Indicators

Assembly 1D (Nominal) R-Value	R_{1D}	R-15.3 (2.70 RSI) + exterior insulation
Transmittance / Resistance without Anomaly	U_o, R_o	“clear wall” U- and R-value without slab and shelf angle
Transmittance / Resistance	U, R	U- and R-values for overall assembly
Surface Temperature Index ¹	T_i	0 = exterior temperature 1 = interior temperature
Linear Transmittance	ψ	Incremental increase in transmittance per linear length of shelf angle and slab

¹Assumptions and limitations for surface temperatures identified in ASHRAE 1365-RP

Nominal (1D) vs. Assembly Performance Indicators

Exterior Insulation 1D R-Value (RSI)	R_{1D} ft ² ·hr·°F / Btu (m ² K / W)	R_o ft ² ·hr·°F / Btu (m ² K / W)	U_o Btu/ft ² ·hr·°F (W/m ² K)	R ft ² ·hr·°F / Btu (m ² K / W)	U Btu/ft ² ·hr·°F (W/m ² K)	ψ Btu/ft hr °F (W/m K)
R-5 (0.88)	R-20.3 (3.58)	R-13.9 (2.45)	0.072 (0.41)	R-8.7 (1.53)	0.115 (0.65)	0.268 (0.464)
R-10 (1.76)	R-25.3 (4.46)	R-17.0 (3.00)	0.059 (0.33)	R-9.3 (1.63)	0.108 (0.61)	0.305 (0.528)
R-15 (2.64)	R-30.3 (5.34)	R-19.8 (3.48)	0.051 (0.29)	R-9.9 (1.74)	0.101 (0.58)	0.314 (0.544)
R-20 (3.52)	R-35.3 (6.22)	R-22.5 (3.96)	0.045 (0.25)	R-10.9 (1.92)	0.092 (0.52)	0.291 (0.504)
R-25 (4.40)	R-40.3 (7.10)	R-24.9 (4.38)	0.040 (0.23)	R-11.6 (2.04)	0.086 (0.49)	0.286 (0.496)

Temperature Indices

	R5	R15	R25	
T_{i1}	0.39	0.59	0.66	Min T on sheathing cavity centre away from slab
T_{i2}	0.66	0.71	0.77	Max T on sheathing, at slab, at steel studs

Detail 5.2.27

Exterior and Interior Insulated Wall Assembly with Spaced Shelf Angle & Brick Ties Supporting Brick Veneer and R-12 Batt Insulation in Stud Cavity – Intermediate Floor Intersection

Thermal Performance Indicators

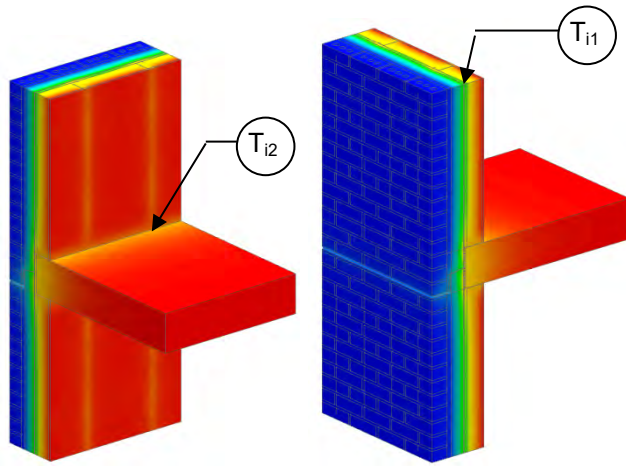

View from Interior

View from Exterior

Assembly 1D (Nominal) R-Value	R_{1D}	R-15.3 (2.70 RSI) + exterior insulation
Transmittance / Resistance without Anomaly	U_o, R_o	“clear wall” U- and R-value without slab and shelf angle
Transmittance / Resistance	U, R	U- and R-values for overall assembly
Surface Temperature Index ¹	T_i	0 = exterior temperature 1 = interior temperature
Linear Transmittance	ψ	Incremental increase in transmittance per linear length of shelf angle and slab

¹Assumptions and limitations for surface temperatures identified in ASHRAE 1365-RP

Nominal (1D) vs. Assembly Performance Indicators

Exterior Insulation 1D R-Value (RSI)	R_{1D} ft ² ·hr·°F / Btu (m ² K / W)	R_o ft ² ·hr·°F / Btu (m ² K / W)	U_o Btu/ft ² ·hr ·°F (W/m ² K)	R ft ² ·hr·°F / Btu (m ² K / W)	U Btu/ft ² ·hr ·°F (W/m ² K)	ψ Btu/ft hr °F (W/m K)
R-5 (0.88)	R-20.3 (3.58)	R-13.9 (2.45)	0.072 (0.41)	R-9.4 (1.65)	0.106 (0.61)	0.217 (0.376)
R-10 (1.76)	R-25.3 (4.46)	R-17.0 (3.00)	0.059 (0.33)	R-11.1 (1.95)	0.090 (0.51)	0.197 (0.341)
R-15 (2.64)	R-30.3 (5.34)	R-19.8 (3.48)	0.051 (0.29)	R-12.6 (2.17)	0.080 (0.46)	0.189 (0.326)
R-20 (3.52)	R-35.3 (6.22)	R-22.5 (3.96)	0.045 (0.25)	R-13.8 (2.43)	0.072 (0.41)	0.174 (0.301)
R-25 (4.40)	R-40.3 (7.10)	R-24.9 (4.38)	0.040 (0.23)	R-15.0 (2.64)	0.067 (0.38)	0.165 (0.290)

Temperature Indices

	R5	R15	R25	
T_{i1}	0.39	0.59	0.69	Min T on sheathing, cavity centre away from slab
T_{i2}	0.72	0.79	0.83	Max T on sheathing, at slab, at steel studs

Detail 5.2.28

Exterior and Interior Insulated Wall Assembly with Stainless Steel Shelf Angle & Brick Ties Supporting Brick Veneer and R-12 Batt Insulation in Stud Cavity – Intermediate Floor Intersection

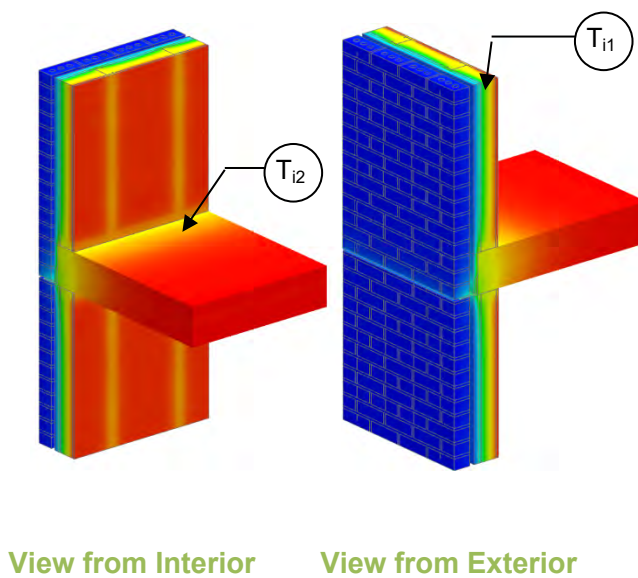

Thermal Performance Indicators

Assembly 1D (Nominal) R-Value	R_{1D}	R-15.3 (2.70 RSI) + exterior insulation
Transmittance / Resistance without Anomaly	U_o, R_o	“clear wall” U- and R-value without slab and shelf angle
Transmittance / Resistance	U, R	U- and R-values for overall assembly
Surface Temperature Index ¹	T_i	0 = exterior temperature 1 = interior temperature
Linear Transmittance	ψ	Incremental increase in transmittance per linear length of shelf angle and slab

¹Assumptions and limitations for surface temperatures identified in ASHRAE 1365-RP

Nominal (1D) vs. Assembly Performance Indicators

Exterior Insulation 1D R-Value (RSI)	R_{1D} ft ² ·hr·°F / Btu (m ² K / W)	R_o ft ² ·hr·°F / Btu (m ² K / W)	U_o Btu/ft ² ·hr·°F (W/m ² K)	R ft ² ·hr·°F / Btu (m ² K / W)	U Btu/ft ² ·hr·°F (W/m ² K)	ψ Btu/ft hr °F (W/m K)
R-5 (0.88)	R-20.3 (3.58)	R-13.9 (2.45)	0.072 (0.41)	R-9.0 (1.59)	0.111 (0.63)	0.242 (0.419)
R-10 (1.76)	R-25.3 (4.46)	R-17.0 (3.00)	0.059 (0.33)	R-10.0 (1.76)	0.100 (0.57)	0.256 (0.443)
R-15 (2.64)	R-30.3 (5.34)	R-19.8 (3.48)	0.051 (0.29)	R-11.0 (1.93)	0.091 (0.52)	0.251 (0.434)
R-20 (3.52)	R-35.3 (6.22)	R-22.5 (3.96)	0.045 (0.25)	R-12.2 (2.15)	0.082 (0.46)	0.231 (0.399)
R-25 (4.40)	R-40.3 (7.10)	R-24.9 (4.38)	0.040 (0.23)	R-13.2 (2.32)	0.076 (0.43)	0.221 (0.383)

Temperature Indices

	R5	R15	R25	
T_{i1}	0.39	0.59	0.69	Min T on sheathing cavity centre away from slab
T_{i2}	0.68	0.73	0.78	Max T on sheathing, at slab, at steel studs

Detail 5.2.29

Exterior and Interior Insulated Wall Assembly with Thermally Broken Steel Shelf Angle & Brick Ties Supporting Brick Veneer and R-12 Batt Insulation in Stud Cavity – Slab Intersection

Thermal Performance Indicators

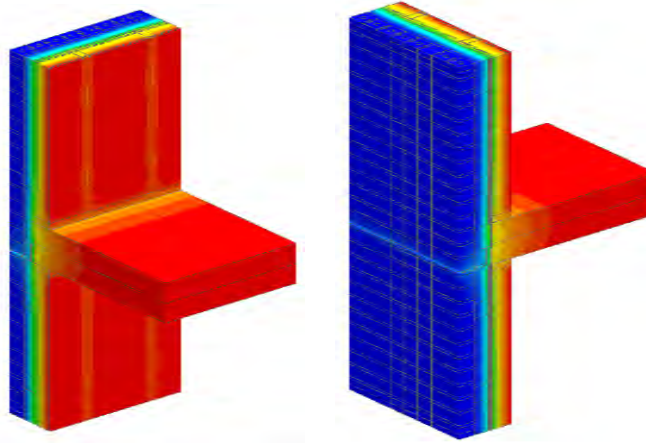

View from Interior

View from Exterior

Assembly 1D (Nominal) R-Value	R_{1D}	R-15.3 (2.70 RSI) + exterior insulation
Transmittance / Resistance without Anomaly	U_o, R_o	“clear wall” U- and R-value without slab and shelf angle
Transmittance / Resistance	U, R	U- and R-values for overall assembly
Surface Temperature Index	T_i	0 = exterior temperature 1 = interior temperature
Linear Transmittance	ψ	Incremental increase in transmittance per linear length of slab with shelf angle

¹Assumptions and limitations for surface temperatures identified in ASHRAE 1365-RP

Scenario

Scenario	Flashing and Shelf Angle
A	Metal Flashing with Steel Shelf Angle and Bolts
B	Self-Adhered Membrane Flashing with Steel Shelf Angle and Bolts

Nominal (1D) vs. Assembly Performance Indicators

Scenario	Exterior Insulation 1D R-Value (RSI)	R_{1D} ft ² ·hr·°F / Btu (m ² K / W)	R_o ft ² ·hr·°F / Btu (m ² K / W)	U_o Btu/ft ² ·hr ·°F (W/m ² K)	R ft ² ·hr·°F / Btu (m ² K / W)	U Btu/ft ² ·hr ·°F (W/m ² K)	ψ Btu/ft hr °F (W/m K)
A	R-15 (2.64)	R-30.3 (5.34)	R-19.8 (3.48)	0.051 (0.29)	R-11.3 (1.98)	0.089 (0.50)	0.237 (0.410)
B	R-15 (2.64)	R-30.3 (5.34)	R-19.8 (3.48)	0.051 (0.29)	R-13.8 (2.43)	0.072 (0.41)	0.135 (0.234)

Detail 5.2.30

Exterior Insulated 3 5/8" x 1 5/8" Steel Stud Wall Assembly with Horizontal Z-girts Supporting Metal Cladding – Armatherm 500 Thermally Broken Slab Projection with Insulated Curb

Thermal Performance Indicators

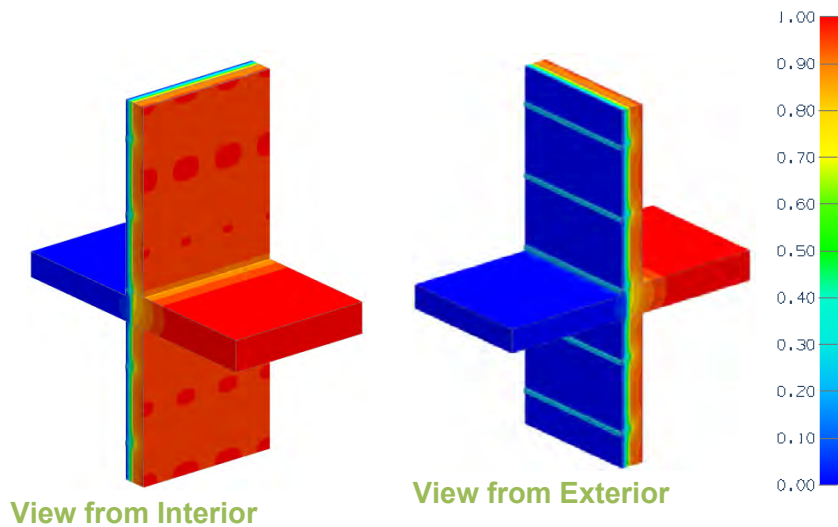

Assembly 1D (Nominal) R-Value	R_{1D}	R-3.2 (0.56 RSI) + insulation
Transmittance / Resistance without Anomaly	U_o, R_o	“clear field” U- and R-value, without slab
Transmittance / Resistance	U, R	U- and R-values for overall assembly
Surface Temperature Index ¹	T_i	0 = exterior temperature 1 = interior temperature
Linear Transmittance	ψ	Incremental increase in transmittance per linear length of slab

¹Surface temperatures are a result of steady-state conductive heat flow with constant heat transfer coefficients. Limitations are identified in final report

Scenarios

Scenario	Thermal Break	Rebar Type
A	Armatherm 500-280	Carbon Steel
B	Armatherm 500-280	Stainless Steel
C	Armatherm 500-080	Carbon Steel
D	Armatherm 500-080	Stainless Steel

Nominal (1D) vs. Assembly Performance Indicators

Base Assembly

Exterior Insulation 1D R-Value (RSI)	R_{1D} ft ² ·hr·°F / Btu (m ² K / W)	R_o ft ² ·hr·°F / Btu (m ² K / W)	U_o Btu/ft ² ·hr ·°F (W/m ² K)
R-14.7 (2.59)	R-17.9 (3.15)	R-11.2 (1.97)	0.089 (0.51)

Slab Linear Transmittance

Scenario	R ft ² ·hr·°F / Btu (m ² K / W)	U Btu/ft ² ·hr ·°F (W/m ² K)	ψ Btu/ft hr °F (W/m K)
A	R-9.1 (1.60)	0.110 (0.63)	0.210 (0.363)
B	R-9.6 (1.69)	0.104 (0.59)	0.147 (0.254)
C	R-9.4 (1.65)	0.107 (0.61)	0.173 (0.299)
D	R-10.0 (1.77)	0.100 (0.57)	0.102 (0.176)

Detail 5.2.31

Exterior Insulated 3 5/8" x 1 5/8" Steel Stud Wall Assembly with Armatherm Z-girts Supporting Metal Cladding – Armatherm 500-080 Thermally Broken Slab Projection with Insulated Curb

Thermal Performance Indicators

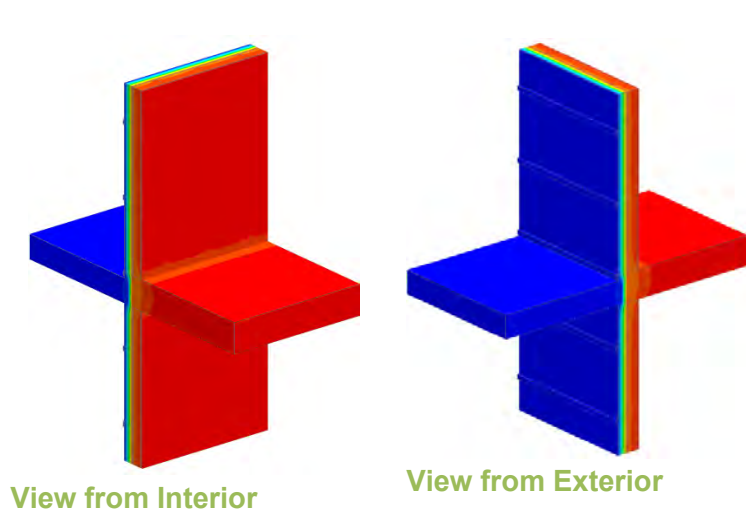

Assembly 1D (Nominal) R-Value	R_{1D}	R-3.2 (0.56 RSI) + insulation
Transmittance / Resistance without Anomaly	U_o, R_o	“clear field” U- and R-value, without roof anchor
Transmittance / Resistance	U, R	U- and R-values for overall assembly
Surface Temperature Index ¹	T_i	0 = exterior temperature 1 = interior temperature
Linear Transmittance	ψ	Incremental increase in transmittance per linear length of slab

¹Surface temperatures are a result of steady-state conductive heat flow with constant heat transfer coefficients. Limitations are identified in final report

Nominal (1D) vs. Assembly Performance Indicators

Base Assembly

Exterior Insulation 1D R-Value (RSI)	R_{1D} ft ² ·hr·°F / Btu (m ² K / W)	R_o ft ² ·hr·°F / Btu (m ² K / W)	U_o Btu/ft ² ·hr ·°F (W/m ² K)
R-14.7 (2.59)	R-17.9 (3.15)	R-17.3 (3.050)	0.058 (0.33)

Slab Linear Transmittance

R ft ² ·hr·°F / Btu (m ² K / W)	U Btu/ft ² ·hr ·°F (W/m ² K)	ψ Btu/ft hr °F (W/m K)
R-14.6 (2.57)	0.068 (0.39)	0.107 (0.185)

Detail 5.2.32

Exterior and Interior Insulated 3 5/8" x 1 5/8" Steel Stud (16" o.c.) Wall Assembly with Nvelope – Eko Thermobacket and NV1 Clip System Supporting Cladding and R-13 Batt Insulation in Stud Cavity – Intermediate Floor Intersection

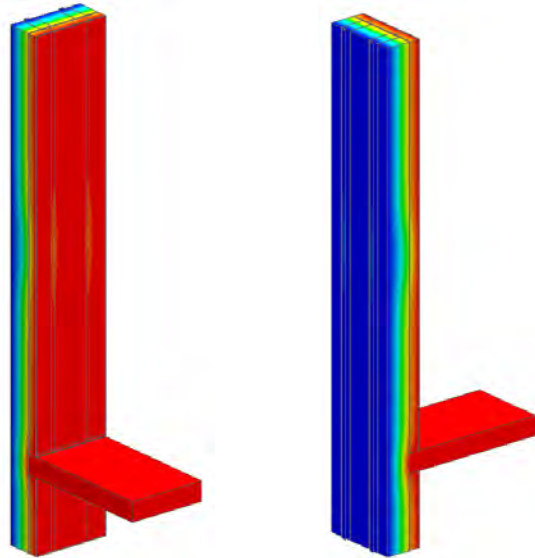

View from Interior

View from Exterior

Thermal Performance Indicators

1.00	Assembly 1D (Nominal) R-Value	R_{1D}	R-15.3 (2.52 RSI) + exterior insulation
0.90	Transmittance / Resistance	U_o, R_o	“clear wall” U- and R-value without slab
0.80	Transmittance / Resistance	U, R	U and R-values for overall assembly
0.70	Surface Temperature Index ¹	T_i	0 = exterior temperature 1 = interior temperature
0.60	Linear Transmittance	ψ	Incremental increase in transmittance per linear length of floor slab
0.50			
0.40			
0.30			
0.20			
0.10			
0.00			

¹Assumptions and limitations for surface temperatures identified in ASHRAE 1365-RP

Nominal (1D) vs. Assembly Performance Indicators

Base Assembly – Wall

Floor Height ft (mm)	Exterior Insulation 1D R-value (RSI)	R_{1D} ft ² ·hr·°F / Btu (m ² K / W)	R_o ft ² ·hr·°F / Btu (m ² K / W)	U_o Btu/ft ² ·hr ·°F (W/m ² K)
11' (3353)	R-42 (7.40)	R-57.3 (10.09)	R-35.6 (6.27)	0.028 (0.16)
13.5' (4115)	R-42 (7.40)	R-57.3 (10.09)	R-37.3 (6.57)	0.027 (0.15)
16' (4877)	R-42 (7.40)	R-57.3 (10.09)	R-38.6 (6.80)	0.026 (0.15)

Uninsulated Floor Intersection Linear Transmittance

Floor Height ft (mm)	Exterior Insulation 1D R-value (RSI)	R ft ² ·hr·°F / Btu (m ² K / W)	U Btu/ft ² ·hr ·°F (W/m ² K)	ψ Btu/ft ·hr ·°F (W/m K)
11' (3353)	R-42 (7.40)	R-35.0 (6.17)	0.029 (0.16)	0.005 (0.009)
13.5' (4115)	R-42 (7.40)	R-36.8 (6.48)	0.027 (0.15)	
16' (4877)	R-42 (7.40)	R-38.2 (6.72)	0.026 (0.15)	

Insulated Floor Intersection Linear Transmittance

Floor Height ft (mm)	Exterior Insulation 1D R-value (RSI)	R ft ² ·hr·°F / Btu (m ² K / W)	U Btu/ft ² ·hr ·°F (W/m ² K)	ψ Btu/ft ·hr ·°F (W/m K)
11' (3353)	R-42 (7.40)	R-35.2 (6.19)	0.028 (0.16)	0.004 (0.006)
13.5' (4115)	R-42 (7.40)	R-36.9 (6.51)	0.027 (0.15)	
16' (4877)	R-42 (7.40)	R-38.3 (6.74)	0.026 (0.15)	

Detail 5.2.33

Exterior Insulated 3 5/8" x 1 5/8" Steel Stud (16" o.c.) Wall Assembly with FERRO Slotted Rap Ties (24" o.c.) and FERRO FAST Thermal Bracket (48" o.c.) Supporting Brick Veneer – Intermediate Floor Intersection

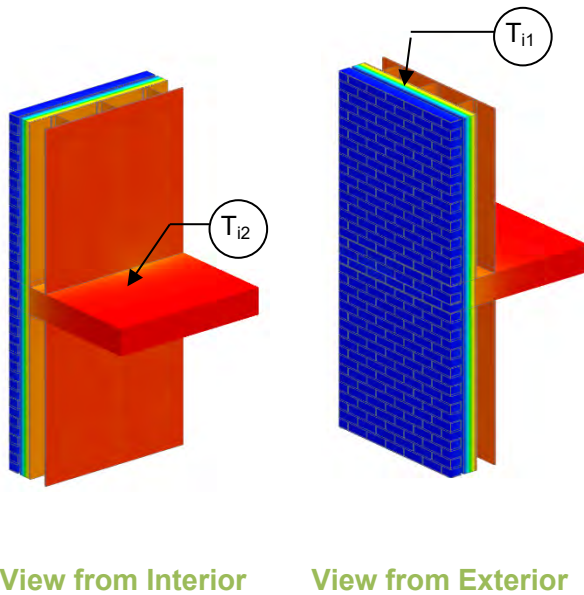

Thermal Performance Indicators

Assembly 1D (Nominal) R-Value	R_{1D}	R-4.3 (0.76 RSI) + exterior insulation
Transmittance / Resistance without Anomaly	U_o, R_o	"clear wall" U- and R-value without slab and shelf angle
Transmittance / Resistance	U, R	U- and R-values for overall assembly
Surface Temperature Index ¹	T_i	0 = exterior temperature 1 = interior temperature
Linear Transmittance	ψ	Incremental increase in transmittance per linear length of slab with shelf angle

Scenario

Scenario	Shelf Angle
A	Direct Anchor Shelf Angle
B	FERRO FAST Thermal Bracket System
C	FERRO FAST Thermal Bracket with Aerogel Coating

Nominal (1D) vs. Assembly Performance Indicators

Scenario	Exterior Insulation 1D R-Value (RSI)	R_{1D} ft ² ·hr·°F / Btu (m ² K / W)	R_o ft ² ·hr·°F / Btu (m ² K / W)	U_o Btu/ft ² ·hr ·°F (W/m ² K)	R ft ² ·hr·°F / Btu (m ² K / W)	U Btu/ft ² ·hr ·°F (W/m ² K)	ψ Btu/ft hr °F (W/m K)
A	R-16.8 (2.96)	R-21.1 (3.72)	R-18.6 (3.28)	0.054 (0.305)	R-10.8 (1.90)	0.093 (0.525)	0.337 (0.583)
	R-24.0 (4.23)	R-28.3 (4.98)	R-24.1 (4.25)	0.041 (0.235)	R-12.2 (2.15)	0.082 (0.466)	0.351 (0.608)
B	R-16.8 (2.96)	R-21.1 (3.72)	R-18.6 (3.28)	0.054 (0.305)	R-16.7 (2.94)	0.060 (0.341)	0.055 (0.095)
	R-24.0 (4.23)	R-28.3 (4.98)	R-24.1 (4.25)	0.041 (0.235)	R-20.8 (3.67)	0.048 (0.272)	0.056 (0.098)
C	R-16.8 (2.96)	R-21.1 (3.72)	R-18.6 (3.28)	0.054 (0.305)	R-17.1 (3.01)	0.059 (0.333)	0.043 (0.074)
	R-24.0 (4.23)	R-28.3 (4.98)	R-24.1 (4.25)	0.041 (0.235)	R-21.5 (3.79)	0.046 (0.264)	0.043 (0.075)

Temperature Indices

	1		2		3		
	R16.8	R24	R16.8	R24	R16.8	R24	
T_{11}	0.89	0.91	0.89	0.92	0.89	0.92	Max T on sheathing cavity centre away from slab
T_{12}	0.67	0.68	0.81	0.82	0.83	0.85	Min T on sheathing, at slab, between steel studs at track

Detail 5.2.34

Owens Corning Exterior Insulated 6" x 1 5/8" Steel Stud (16" o.c.) Wall Assembly with Thermally Isolated Vertical Brackets and Rail System (24" o.c.) Supporting Metal Cladding – Intermediate Floor Intersection

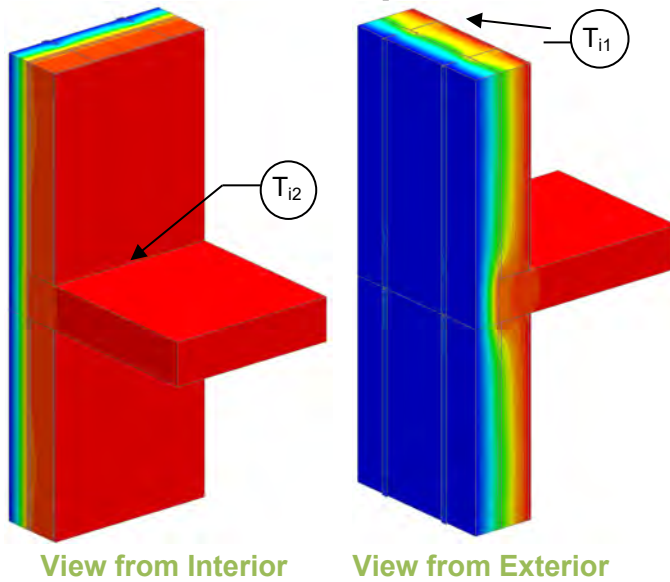

Thermal Performance Indicators

Assembly 1D (Nominal) R-Value	R_{1D}	R-3.3 (0.58 RSI) + exterior insulation
Transmittance / Resistance without Anomaly	U_o, R_o	“clear wall” U- and R-value without slab and shelf angle
Transmittance / Resistance	U, R	U- and R-values for overall assembly
Surface Temperature Index ¹	T_i	0 = exterior temperature 1 = interior temperature
Linear Transmittance	ψ	Incremental increase in transmittance per linear length of slab

¹Assumptions and limitations for surface temperatures identified in ASHRAE 1365-RP

Nominal (1D) vs. Assembly Performance Indicators

Exterior Insulation 1D R-Value (RSI)	R_{1D} ft ² ·hr·°F / Btu (m ² K / W)	R_o ft ² ·hr·°F / Btu (m ² K / W)	U_o Btu/ft ² ·hr·°F (W/m ² K)	R ft ² ·hr·°F / Btu (m ² K / W)	U Btu/ft ² ·hr·°F (W/m ² K)	ψ Btu/ft hr °F (W/m K)
R-8.4 (1.48)	R-11.7 (2.06)	R-10.0 (1.77)	0.100 (0.57)	R-9.7 (1.72)	0.103 (0.58)	0.020 (0.034)
R-21.0 (3.70)	R-24.3 (4.28)	R-17.6 (3.10)	0.057 (0.32)	R-17.0 (3.00)	0.059 (0.33)	0.013 (0.023)

Temperature Indices

	R8.4	R21	
T_{i1}	0.80	0.89	Min T on sheathing cavity centre, away from slab
T_{i2}	0.84	0.91	Max T on sheathing, at slab, between steel studs

Detail 5.2.35

Exterior and Interior Insulated 6" x 1 5/8" Steel Stud (16" o.c.) Wall Assembly with Thermally Isolated Vertical Brackets and Rail System (24" o.c.) Supporting Metal Cladding and Owens Corning R-20 Batt in Stud Cavity – Intermediate Floor Intersection

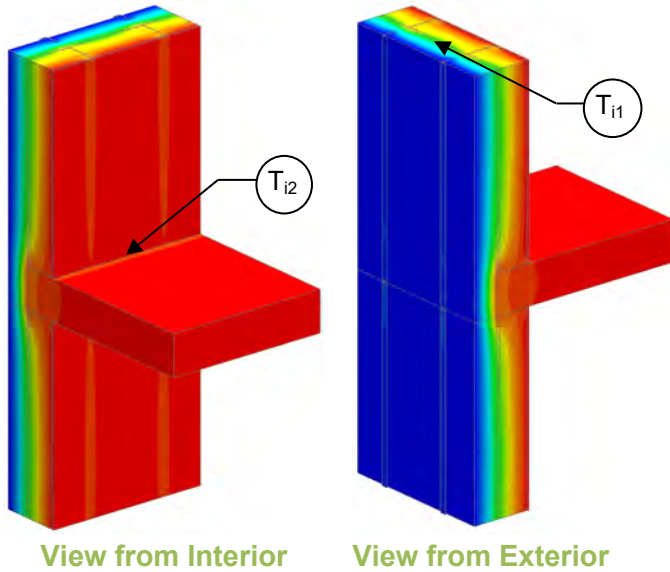

Thermal Performance Indicators

Assembly 1D (Nominal) R-Value	R_{1D}	R-22.4 (3.94 RSI) + exterior insulation
Transmittance / Resistance without Anomaly	U_o, R_o	“clear wall” U- and R-value without slab and shelf angle
Transmittance / Resistance	U, R	U- and R-values for overall assembly
Surface Temperature Index ¹	T_i	0 = exterior temperature 1 = interior temperature
Linear Transmittance	ψ	Incremental increase in transmittance per linear length of slab

¹Assumptions and limitations for surface temperatures identified in ASHRAE 1365-RP

Nominal (1D) vs. Assembly Performance Indicators

Exterior Insulation 1D R-Value (RSI)	R_{1D} ft ² ·hr·°F / Btu (m ² K / W)	R_o ft ² ·hr·°F / Btu (m ² K / W)	U_o Btu/ft ² ·hr·°F (W/m ² K)	R ft ² ·hr·°F / Btu (m ² K / W)	U Btu/ft ² ·hr·°F (W/m ² K)	ψ Btu/ft hr °F (W/m K)
R-8.4 (1.48)	R-30.8 (5.42)	R-18.3 (3.23)	0.055 (0.31)	R-15.3 (2.69)	0.065 (0.37)	0.076 (0.132)
R-21.0 (3.70)	R-43.4 (7.64)	R-25.8 (4.54)	0.039 (0.22)	R-22.5 (3.96)	0.045 (0.25)	0.040 (0.069)

Temperature Indices

	R8.4	R21	
T_{i1}	0.35	0.55	Min T on sheathing cavity centre, away from slab
T_{i2}	0.80	0.88	Max T on sheathing, at slab, between steel studs

Detail 5.2.36

Exterior and Interior Insulated 6" x 1 5/8" Steel Stud (16" o.c.) Wall Assembly with Thermally Isolated Vertical Brackets and Rail System (24" o.c.) Supporting Metal Cladding and Owens Corning R-22.5 Batt in Stud Cavity – Intermediate Floor Intersection

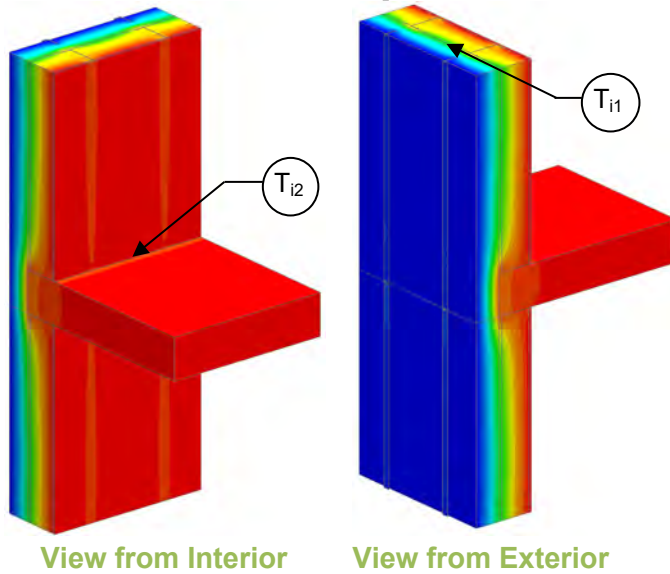

Thermal Performance Indicators

Assembly 1D (Nominal) R-Value	R_{1D}	R-24.9 (4.38 RSI) + exterior insulation
Transmittance / Resistance without Anomaly	U_o, R_o	“clear wall” U- and R-value without slab and shelf angle
Transmittance / Resistance	U, R	U- and R-values for overall assembly
Surface Temperature Index ¹	T_i	0 = exterior temperature 1 = interior temperature
Linear Transmittance	ψ	Incremental increase in transmittance per linear length of slab

¹Assumptions and limitations for surface temperatures identified in ASHRAE 1365-RP

Nominal (1D) vs. Assembly Performance Indicators

Exterior Insulation 1D R-Value (RSI)	R_{1D} ft ² ·hr·°F / Btu (m ² K / W)	R_o ft ² ·hr·°F / Btu (m ² K / W)	U_o Btu/ft ² ·hr·°F (W/m ² K)	R ft ² ·hr·°F / Btu (m ² K / W)	U Btu/ft ² ·hr·°F (W/m ² K)	ψ Btu/ft hr °F (W/m K)
R-8.4 (1.48)	R-33.3 (5.86)	R-19.0 (3.34)	0.053 (0.30)	R-15.6 (2.75)	0.064 (0.36)	0.079 (0.136)
R-21.0 (3.70)	R-45.9 (8.08)	R-26.4 (4.64)	0.038 (0.22)	R-22.8 (4.02)	0.044 (0.25)	0.041 (0.071)

Temperature Indices

	R8.4	R21	
T_{i1}	0.33	0.53	Min T on sheathing cavity centre, away from slab
T_{i2}	0.80	0.87	Max T on sheathing, at slab, between steel studs

Detail 5.2.37

Exterior and Interior Insulated 6" x 1 5/8" Steel Stud (16" o.c.) Wall Assembly with Thermally Isolated Vertical Brackets and Rail System (24" o.c.) Supporting Metal Cladding and Owens Corning R-24 Batt in Stud Cavity – Intermediate Floor Intersection

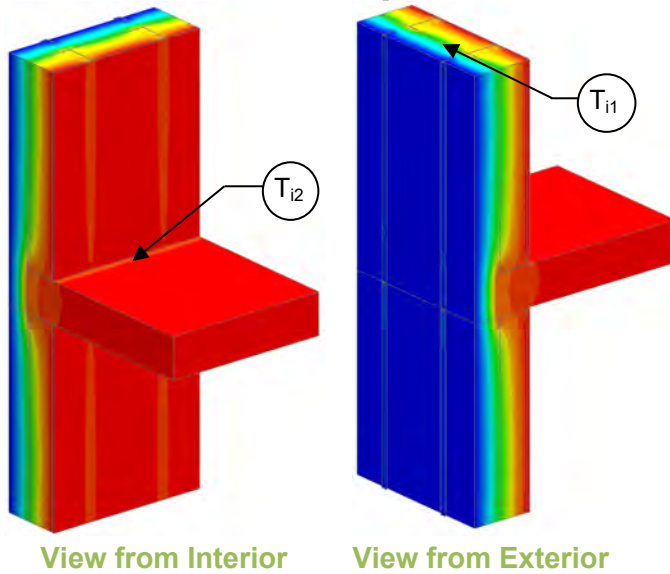

Thermal Performance Indicators

Assembly 1D (Nominal) R-Value	R_{1D}	R-26.4 (4.65 RSI) + exterior insulation
Transmittance / Resistance without Anomaly	U_o, R_o	“clear wall” U- and R-value without slab and shelf angle
Transmittance / Resistance	U, R	U- and R-values for overall assembly
Surface Temperature Index ¹	T_i	0 = exterior temperature 1 = interior temperature
Linear Transmittance	ψ	Incremental increase in transmittance per linear length of slab

¹Assumptions and limitations for surface temperatures identified in ASHRAE 1365-RP

Nominal (1D) vs. Assembly Performance Indicators

Exterior Insulation 1D R-Value (RSI)	R_{1D} ft ² ·hr·°F / Btu (m ² K / W)	R_o ft ² ·hr·°F / Btu (m ² K / W)	U_o Btu/ft ² ·hr·°F (W/m ² K)	R ft ² ·hr·°F / Btu (m ² K / W)	U Btu/ft ² ·hr·°F (W/m ² K)	ψ Btu/ft hr °F (W/m K)
R-8.4 (1.48)	R-34.8 (6.13)	R-19.3 (3.40)	0.052 (0.29)	R-15.8 (2.78)	0.063 (0.36)	0.080 (0.139)
R-21.0 (3.70)	R-47.4 (8.34)	R-26.7 (4.71)	0.037 (0.21)	R-23.0 (4.05)	0.043 (0.25)	0.042 (0.073)

Temperature Indices

	R8.4	R21	
T_{i1}	0.32	0.52	Min T on sheathing cavity centre, away from slab
T_{i2}	0.80	0.87	Max T on sheathing, at slab, between steel studs

Detail 5.2.38

Exterior Insulated 6" x 1 5/8" Steel Stud (16" o.c.) Wall Assembly with FRP Vertical Brackets and Rail System Supporting Metal Cladding – Intermediate Floor Intersection

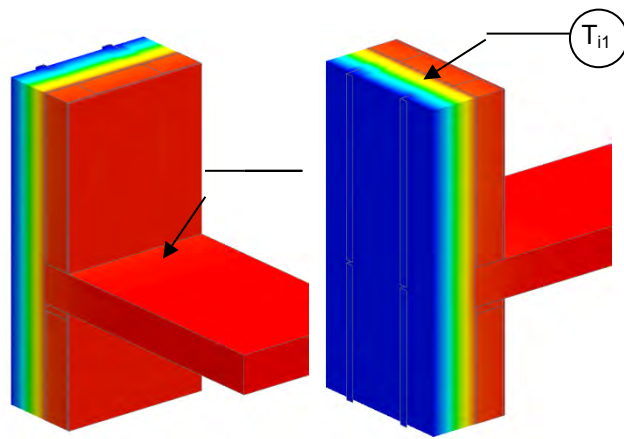

View from Interior

View from Exterior

Thermal Performance Indicators

Assembly 1D (Nominal) R-Value	R_{1D}	R-3.2 (0.56 RSI) + exterior insulation
Transmittance / Resistance without Anomaly	U_o, R_o	“clear wall” U- and R-value without slab
Transmittance / Resistance	U, R	U- and R-values for overall assembly
Surface Temperature Index ¹	T_i	0 = exterior temperature 1 = interior temperature
Linear Transmittance	ψ	Incremental increase in transmittance per linear length of slab

¹Assumptions and limitations for surface temperatures identified in ASHRAE 1365-RP

Nominal (1D) vs. Assembly Performance Indicators

Exterior Insulation 1D R-Value (RSI)	R_{1D} ft ² ·hr·°F / Btu (m ² K / W)	R_o ft ² ·hr·°F / Btu (m ² K / W)	U_o Btu/ft ² ·hr ·°F (W/m ² K)	R ft ² ·hr·°F / Btu (m ² K / W)	U Btu/ft ² ·hr ·°F (W/m ² K)	ψ Btu/ft hr °F (W/m K)
R-42 (7.40)	R-45.2 (7.96)	R-40.0 (7.04)	0.025 (0.14)	R-39.5 (6.96)	0.025 (0.14)	0.002 (0.003)

Temperature Indices

	R42	
T_{i1}	0.94	Min T on sheathing cavity centre away from slab
T_{i2}	0.96	Max T on sheathing, at slab, at steel studs

Detail 5.2.39

Exterior and Interior Insulated 6" x 1 5/8" Steel Stud (16" o.c.) Wall Assembly with FRP Vertical Brackets and Rail System Supporting Metal Cladding and R-19 Batt in Stud Cavity – Intermediate Floor Intersection

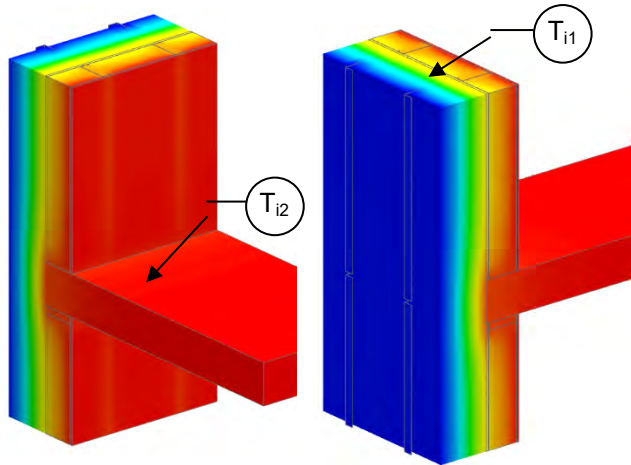

View from Interior

View from Exterior

Thermal Performance Indicators

Assembly 1D (Nominal) R-Value	R_{1D}	R-21.3 (3.75 RSI) + exterior insulation
Transmittance / Resistance without Anomaly	U_o, R_o	“clear wall” U- and R-value without slab
Transmittance / Resistance	U, R	U- and R-values for overall assembly
Surface Temperature Index ¹	T_i	0 = exterior temperature 1 = interior temperature
Linear Transmittance	ψ	Incremental increase in transmittance per linear length of slab

¹Assumptions and limitations for surface temperatures identified in ASHRAE 1365-RP

Nominal (1D) vs. Assembly Performance Indicators

Exterior Insulation 1D R-Value (RSI)	R_{1D} ft ² ·hr·°F / Btu (m ² K / W)	R_o ft ² ·hr·°F / Btu (m ² K / W)	U_o Btu/ft ² ·hr ·°F (W/m ² K)	R ft ² ·hr·°F / Btu (m ² K / W)	U Btu/ft ² ·hr ·°F (W/m ² K)	ψ Btu/ft hr °F (W/m K)
R-42 (7.40)	R-63.3 (11.15)	R-48.3 (8.51)	0.021 (0.12)	R-45.0 (7.92)	0.022 (0.13)	0.008 (0.015)

Temperature Indices

	R42	
T_{i1}	0.76	Min T on sheathing cavity centre away from slab
T_{i2}	0.94	Max T on sheathing, at slab, between steel studs

Detail 5.2.40

Exterior Insulated 3 5/8" x 1 5/8" Steel Stud (16" o.c.) Wall Assembly with Horizontal Z-girts (24" o.c.) Supporting Metal Cladding – Isokorb K65-V8 Thermally Broken Slab Projection with Insulated Curb

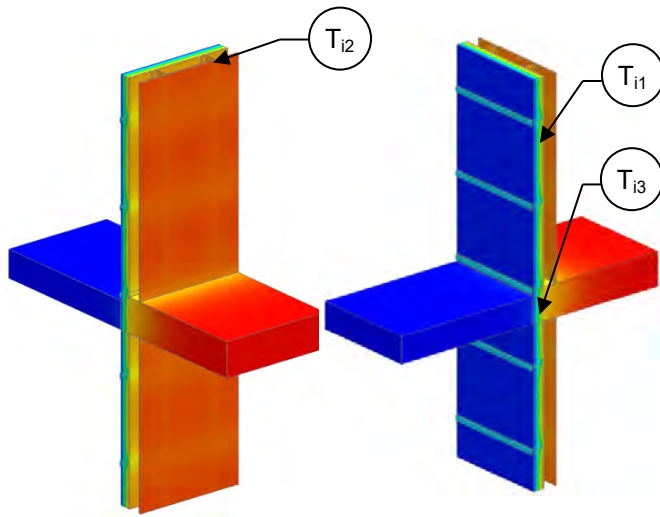

View from Interior

View from Exterior

Thermal Performance Indicators



Assembly 1D (Nominal) R-Value	R_{1D}	R-3.2 (0.56 RSI) + exterior insulation
Transmittance / Resistance without Anomaly	U_o, R_o	“clear wall” U- and R-value, without slab
Transmittance / Resistance	U, R	U- and R-values for overall assembly
Surface Temperature Index ¹	T_i	0 = exterior temperature 1 = interior temperature
Linear Transmittance	ψ	Incremental increase in transmittance per linear length of slab

¹Assumptions and limitations for surface temperatures identified in ASHRAE 1365-RP

Nominal (1D) vs. Assembly Performance Indicators

Exterior Insulation 1D R-Value (RSI)	R_{1D} ft ² ·hr·°F / Btu (m ² K / W)	R_o ft ² ·hr·°F / Btu (m ² K / W)	U_o Btu/ft ² ·hr ·°F (W/m ² K)	R ft ² ·hr·°F / Btu (m ² K / W)	U Btu/ft ² ·hr ·°F (W/m ² K)	ψ Btu/ft hr °F (W/m K)
R-15 (2.64)	R-18.2 (3.20)	R-11.3 (1.99)	0.088 (0.50)	R-9.7 (1.71)	0.103 (0.58)	0.143 (0.248)

Temperature Indices

T_{i1}	0.75	Min T on sheathing away from slab, between studs at girts
T_{i2}	0.86	Max T on sheathing away from slab, between girts at studs
T_{i3}	0.78	Min T on slab exposed to interior air, at sheathing between studs

Detail 5.2.41

Exterior Insulated 3 5/8" x 1 5/8" Steel Stud (16" o.c.) Wall Assembly with Horizontal Z-girts (24" o.c.) Supporting Metal Cladding – Isokorb K10-V6 Thermally Broken Slab Projection with Insulated Curb

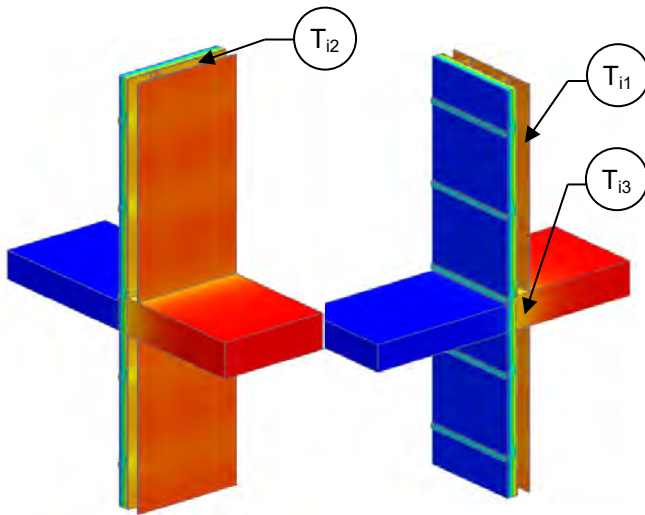

View from Interior

View from Exterior

Thermal Performance Indicators



Assembly 1D (Nominal) R-Value	R_{1D}	R-3.2 (0.56 RSI) + exterior insulation
Transmittance / Resistance without Anomaly	U_o, R_o	“clear wall” U- and R-value, without slab
Transmittance / Resistance	U, R	U- and R-values for overall assembly
Surface Temperature Index ¹	T_i	0 = exterior temperature 1 = interior temperature
Linear Transmittance	ψ	Incremental increase in transmittance per linear length of slab

¹Assumptions and limitations for surface temperatures identified in ASHRAE 1365-RP

Nominal (1D) vs. Assembly Performance Indicators

Exterior Insulation 1D R-Value (RSI)	R_{1D} ft ² ·hr·°F / Btu (m ² K / W)	R_o ft ² ·hr·°F / Btu (m ² K / W)	U_o Btu/ft ² ·hr ·°F (W/m ² K)	R ft ² ·hr·°F / Btu (m ² K / W)	U Btu/ft ² ·hr ·°F (W/m ² K)	ψ Btu/ft hr °F (W/m K)
R-15 (2.64)	R-18.2 (3.20)	R-11.3 (1.99)	0.088 (0.50)	R-10.4 (1.83)	0.096 (0.55)	0.075 (0.130)

Temperature Indices

T_{i1}	0.75	Min T on sheathing away from slab, between studs at girts
T_{i2}	0.86	Max T on sheathing away from slab, between girts at studs
T_{i3}	0.80	Min T on slab exposed to interior air, at sheathing between studs

Detail 5.2.42

Exterior Insulated 3 5/8" x 1 5/8" Steel Stud (16" o.c.) Wall Assembly with Horizontal Z-girts (24" o.c.) Supporting Metal Cladding – Isokorb KXT65-V8 Thermally Broken Slab Projection with Insulated Curb

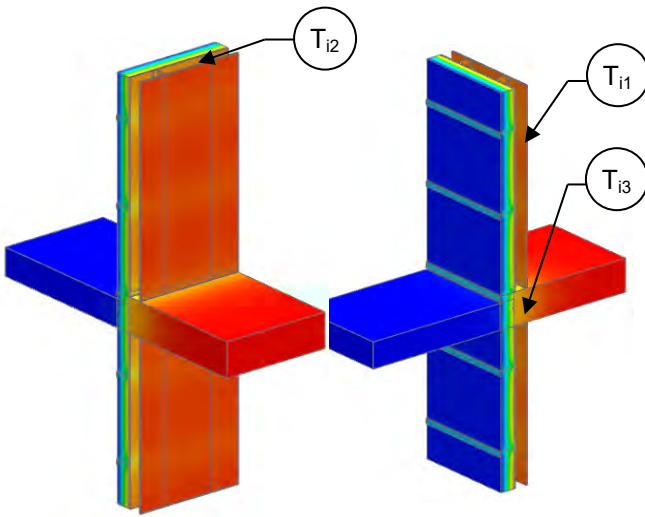

View from Interior

View from Exterior

Thermal Performance Indicators

Assembly 1D (Nominal) R-Value	R_{1D}	R-3.2 (0.56 RSI) + exterior insulation
Transmittance / Resistance without Anomaly	U_o, R_o	“clear wall” U- and R-value, without slab
Transmittance / Resistance	U, R	U- and R-values for overall assembly
Surface Temperature Index ¹	T_i	0 = exterior temperature 1 = interior temperature
Linear Transmittance	ψ	Incremental increase in transmittance per linear length of slab

¹Assumptions and limitations for surface temperatures identified in ASHRAE 1365-RP

Nominal (1D) vs. Assembly Performance Indicators

Exterior Insulation 1D R-Value (RSI)	R_{1D} ft ² ·hr·°F / Btu (m ² K / W)	R_o ft ² ·hr·°F / Btu (m ² K / W)	U_o Btu/ft ² ·hr ·°F (W/m ² K)	R ft ² ·hr·°F / Btu (m ² K / W)	U Btu/ft ² ·hr ·°F (W/m ² K)	ψ Btu/ft hr °F (W/m K)
R-22.5 (3.96)	R-25.7 (4.52)	R-13.8 (2.44)	0.072 (0.41)	R-11.8 (2.07)	0.085 (0.48)	0.126 (0.217)

Temperature Indices

T_{i1}	0.78	Min T on sheathing away from slab, between studs at girts
T_{i2}	0.89	Max T on sheathing away from slab, between girts at studs
T_{i3}	0.81	Min T on slab exposed to interior air, at sheathing between studs

Detail 5.2.43

Exterior Insulated 3 5/8" x 1 5/8" Steel Stud (16" o.c.) Wall Assembly with Horizontal Z-girts (24" o.c.) Supporting Metal Cladding – Isokorb KXT15-V6 Thermally Broken Slab Projection with Insulated Curb

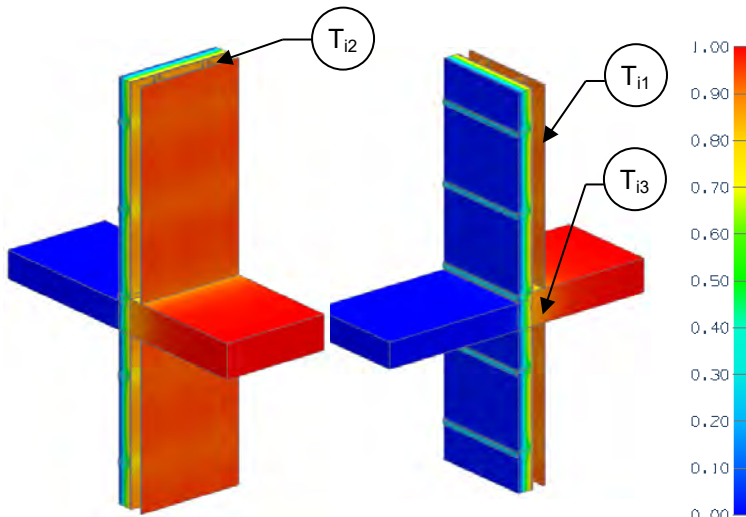

View from Interior

View from Exterior

Thermal Performance Indicators

Assembly 1D (Nominal) R-Value	R_{1D}	R-3.2 (0.56 RSI) + exterior insulation
Transmittance / Resistance without Anomaly	U_o, R_o	“clear wall” U- and R-value, without slab
Transmittance / Resistance	U, R	U- and R-values for overall assembly
Surface Temperature Index ¹	T_i	0 = exterior temperature 1 = interior temperature
Linear Transmittance	ψ	Incremental increase in transmittance per linear length of slab

¹Assumptions and limitations for surface temperatures identified in ASHRAE 1365-RP

Nominal (1D) vs. Assembly Performance Indicators

Exterior Insulation 1D R-Value (RSI)	R_{1D} ft ² ·hr·°F / Btu (m ² K / W)	R_o ft ² ·hr·°F / Btu (m ² K / W)	U_o Btu/ft ² ·hr·°F (W/m ² K)	R ft ² ·hr·°F / Btu (m ² K / W)	U Btu/ft ² ·hr·°F (W/m ² K)	ψ Btu/ft hr °F (W/m K)
R-22.5 (3.96)	R-25.7 (4.52)	R-13.8 (2.44)	0.072 (0.41)	R-12.6 (2.22)	0.079 (0.45)	0.068 (0.118)

Temperature Indices

T_{i1}	0.78	Min T on sheathing away from slab, between studs at girts
T_{i2}	0.89	Max T on sheathing away from slab, between girts at studs
T_{i3}	0.83	Min T on slab exposed to interior air, at sheathing between studs

Detail 5.2.44

Exterior and Interior Insulated 3 5/8" x 1 5/8" Steel Stud (16" o.c.) Wall Assembly with Horizontal Z-girts (24" o.c.) Supporting Metal Cladding and R-12 Batt Insulation in Stud Cavity – Isokorb K65-V8 Thermally Broken Slab Projection with Insulated Curb

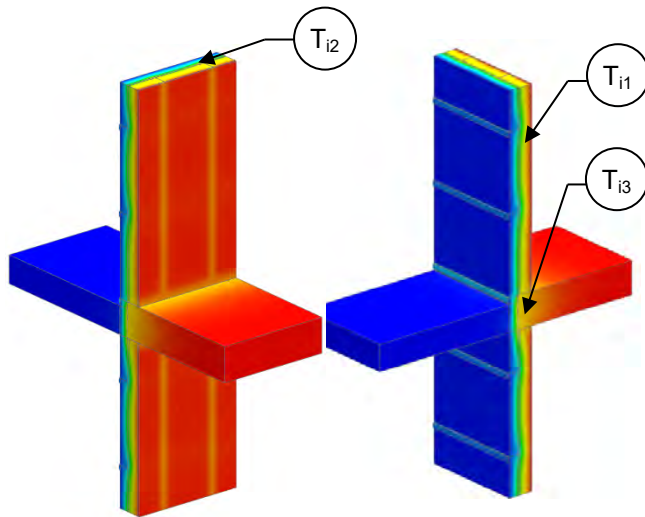

View from Interior

View from Exterior

Thermal Performance Indicators

Assembly 1D (Nominal) R-Value	R_{1D}	R-14.3 (2.52 RSI) + exterior insulation
Transmittance / Resistance without Anomaly	U_o, R_o	“clear wall” U- and R-value, without slab
Transmittance / Resistance	U, R	U- and R-values for overall assembly
Surface Temperature Index ¹	T_i	0 = exterior temperature 1 = interior temperature
Linear Transmittance	ψ	Incremental increase in transmittance per linear length of slab

¹Assumptions and limitations for surface temperatures identified in ASHRAE 1365-RP

Nominal (1D) vs. Assembly Performance Indicators

Exterior Insulation 1D R-Value (RSI)	R_{1D} ft ² ·hr·°F / Btu (m ² K / W)	R_o ft ² ·hr·°F / Btu (m ² K / W)	U_o Btu/ft ² ·hr·°F (W/m ² K)	R ft ² ·hr·°F / Btu (m ² K / W)	U Btu/ft ² ·hr·°F (W/m ² K)	ψ Btu/ft hr °F (W/m K)
R-15 (2.64)	R-29.3 (5.16)	R-18.5 (3.25)	0.054 (0.31)	R-13.5 (2.38)	0.074 (0.42)	0.196 (0.339)

Temperature Indices

T_{i1}	0.36	Min T on sheathing away from slab, between studs at girts
T_{i2}	0.70	Max T on sheathing away from slab, between girts at studs
T_{i3}	0.63	Min T on slab exposed to interior air, at sheathing between studs

Detail 5.2.45

Exterior and Interior Insulated 3 5/8" x 1 5/8" Steel Stud (16" o.c.) Wall Assembly with Horizontal Z-girts (24" o.c.) Supporting Metal Cladding and R-12 Batt Insulation in Stud Cavity – Isokorb K10-V6 Thermally Broken Slab Projection with Insulated Curb

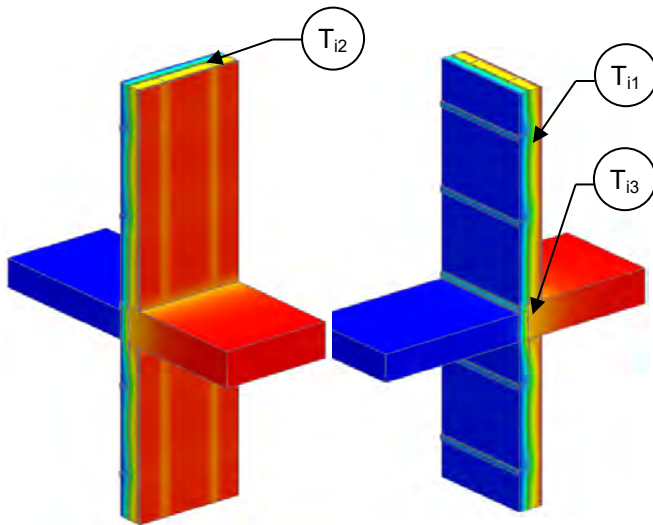

View from Interior

View from Exterior

Thermal Performance Indicators

Assembly 1D (Nominal) R-Value	R_{1D}	R-14.3 (2.52 RSI) + exterior insulation
Transmittance / Resistance without Anomaly	U_o, R_o	“clear wall” U- and R-value, without slab
Transmittance / Resistance	U, R	U- and R-values for overall assembly
Surface Temperature Index ¹	T_i	0 = exterior temperature 1 = interior temperature
Linear Transmittance	ψ	Incremental increase in transmittance per linear length of slab

¹Assumptions and limitations for surface temperatures identified in ASHRAE 1365-RP

Nominal (1D) vs. Assembly Performance Indicators

Exterior Insulation 1D R-Value (RSI)	R_{1D} ft ² ·hr·°F / Btu (m ² K / W)	R_o ft ² ·hr·°F / Btu (m ² K / W)	U_o Btu/ft ² ·hr·°F (W/m ² K)	R ft ² ·hr·°F / Btu (m ² K / W)	U Btu/ft ² ·hr·°F (W/m ² K)	ψ Btu/ft hr °F (W/m K)
R-15 (2.64)	R-29.3 (5.16)	R-18.5 (3.25)	0.054 (0.31)	R-14.8 (2.61)	0.067 (0.38)	0.131 (0.226)

Temperature Indices

T_{i1}	0.36	Min T on sheathing away from slab, between studs at girts
T_{i2}	0.70	Max T on sheathing away from slab, between girts at studs
T_{i3}	0.65	Min T on slab exposed to interior air, at sheathing between studs

Detail 5.2.46

Exterior and Interior Insulated 3 5/8" x 1 5/8" Steel Stud (16" o.c.) Wall Assembly with Horizontal Z-girts (24" o.c.) Supporting Metal Cladding and R-12 Batt Insulation in Stud Cavity – Isokorb KXT65-V8 Thermally Broken Slab Projection with Insulated Curb

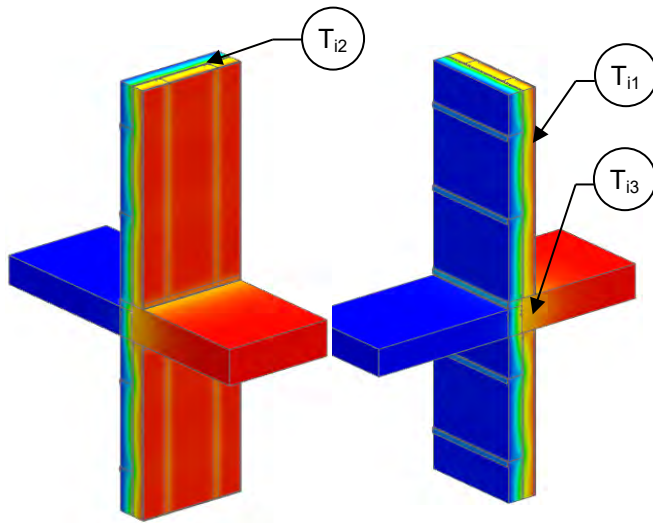

View from Interior

View from Exterior

Thermal Performance Indicators



Assembly 1D (Nominal) R-Value	R_{1D}	R-14.3 (2.52 RSI) + exterior insulation
Transmittance / Resistance without Anomaly	U_o, R_o	“clear wall” U- and R-value, without slab
Transmittance / Resistance	U, R	U- and R-values for overall assembly
Surface Temperature Index ¹	T_i	0 = exterior temperature 1 = interior temperature
Linear Transmittance	ψ	Incremental increase in transmittance per linear length of slab

¹Assumptions and limitations for surface temperatures identified in ASHRAE 1365-RP

Nominal (1D) vs. Assembly Performance Indicators

Exterior Insulation 1D R-Value (RSI)	R_{1D} ft ² ·hr·°F / Btu (m ² K / W)	R_o ft ² ·hr·°F / Btu (m ² K / W)	U_o Btu/ft ² ·hr·°F (W/m ² K)	R ft ² ·hr·°F / Btu (m ² K / W)	U Btu/ft ² ·hr·°F (W/m ² K)	ψ Btu/ft hr °F (W/m K)
R-22.5 (3.96)	R-36.8 (6.48)	R-21.4 (3.76)	0.047 (0.27)	R-15.8 (2.79)	0.063 (0.36)	0.161 (0.278)

Temperature Indices

T_{i1}	0.41	Min T on sheathing away from slab, between studs at girts
T_{i2}	0.74	Max T on sheathing away from slab, between girts at studs
T_{i3}	0.68	Min T on slab exposed to interior air, at sheathing between studs

Detail 5.2.47

Exterior and Interior Insulated 3 5/8" x 1 5/8" Steel Stud (16" o.c.) Wall Assembly with Horizontal Z-girts (24" o.c.) Supporting Metal Cladding and R-12 Batt Insulation in Stud Cavity – Isokorb KXT15-V6 Thermally Broken Slab Projection with Insulated Curb

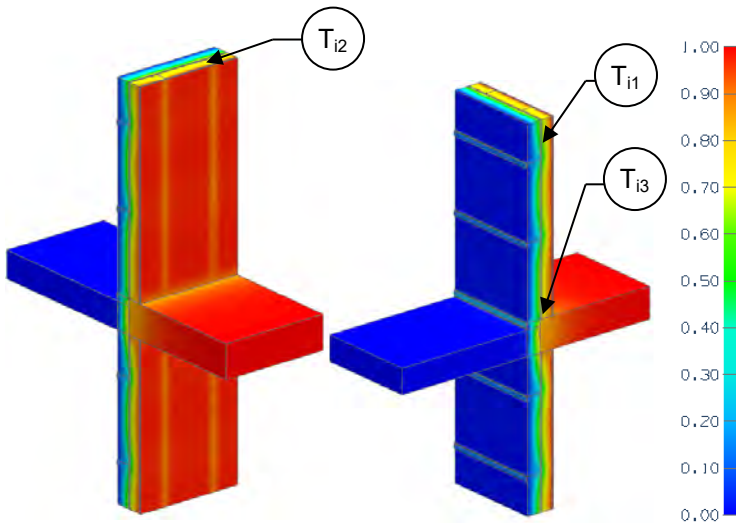

View from Interior

View from Exterior

Thermal Performance Indicators

Assembly 1D (Nominal) R-Value	R_{1D}	R-14.3 (2.52 RSI) + exterior insulation
Transmittance / Resistance without Anomaly	U_o, R_o	“clear wall” U- and R-value, without slab
Transmittance / Resistance	U, R	U- and R-values for overall assembly
Surface Temperature Index ¹	T_i	0 = exterior temperature 1 = interior temperature
Linear Transmittance	ψ	Incremental increase in transmittance per linear length of slab

¹Assumptions and limitations for surface temperatures identified in ASHRAE 1365-RP

Nominal (1D) vs. Assembly Performance Indicators

Exterior Insulation 1D R-Value (RSI)	R_{1D} ft ² ·hr·°F / Btu (m ² K / W)	R_o ft ² ·hr·°F / Btu (m ² K / W)	U_o Btu/ft ² ·hr·°F (W/m ² K)	R ft ² ·hr·°F / Btu (m ² K / W)	U Btu/ft ² ·hr·°F (W/m ² K)	ψ Btu/ft hr °F (W/m K)
R-22.5 (3.96)	R-36.8 (6.48)	R-21.4 (3.76)	0.047 (0.27)	R-17.4 (3.06)	0.058 (0.33)	0.106 (0.183)

Temperature Indices

T_{i1}	0.41	Min T on sheathing away from slab, between studs at girts
T_{i2}	0.74	Max T on sheathing away from slab, between girts at studs
T_{i3}	0.70	Min T on slab exposed to interior air, at sheathing between studs

Detail 5.2.48

Exterior and Interior Insulated Wall Assembly with Stainless Steel Spaced Shelf Angle & Brick Ties Supporting Brick Veneer and R-12 Batt Insulation in Stud Cavity – Intermediate Floor Intersection

Thermal Performance Indicators

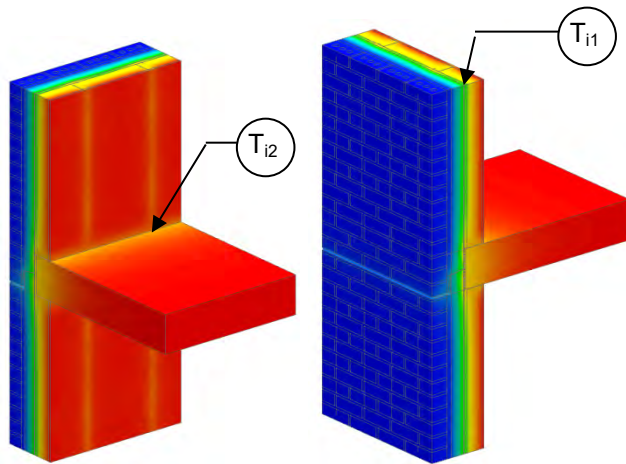

View from Interior

View from Exterior

Assembly 1D (Nominal) R-Value	R_{1D}	R-15.3 (2.70 RSI) + exterior insulation
Transmittance / Resistance without Anomaly	U_o, R_o	“clear wall” U- and R-value without slab and shelf angle
Transmittance / Resistance	U, R	U- and R-values for overall assembly
Surface Temperature Index ¹	T_i	0 = exterior temperature 1 = interior temperature
Linear Transmittance	ψ	Incremental increase in transmittance per linear length of shelf angle and slab

¹Assumptions and limitations for surface temperatures identified in ASHRAE 1365-RP

Nominal (1D) vs. Assembly Performance Indicators

Exterior Insulation 1D R-Value (RSI)	R_{1D} ft ² ·hr·°F / Btu (m ² K / W)	R_o ft ² ·hr·°F / Btu (m ² K / W)	U_o Btu/ft ² ·hr·°F (W/m ² K)	R ft ² ·hr·°F / Btu (m ² K / W)	U Btu/ft ² ·hr·°F (W/m ² K)	ψ Btu/ft hr °F (W/m K)
R-5 (0.88)	R-20.3 (3.58)	R-13.9 (2.45)	0.072 (0.41)	R-9.6 (1.70)	0.104 (0.59)	0.198 (0.343)
R-10 (1.76)	R-25.3 (4.46)	R-17.0 (3.00)	0.059 (0.33)	R-11.5 (2.02)	0.087 (0.49)	0.175 (0.304)
R-15 (2.64)	R-30.3 (5.34)	R-19.8 (3.48)	0.051 (0.29)	R-13.0 (2.28)	0.077 (0.44)	0.165 (0.285)
R-20 (3.52)	R-35.3 (6.22)	R-22.5 (3.96)	0.045 (0.25)	R-14.6 (2.57)	0.069 (0.39)	0.149 (0.257)
R-25 (4.40)	R-40.3 (7.10)	R-24.9 (4.38)	0.040 (0.23)	R-16.0 (2.82)	0.062 (0.35)	0.138 (0.239)

Temperature Indices

	R5	R15	R25	
T_{i1}	0.39	0.59	0.69	Min T on sheathing, cavity centre away from slab
T_{i2}	0.70	0.78	0.82	Max T on sheathing, at slab, at steel studs

Detail 5.2.49

Exterior and Interior Insulated Wall Assembly with Thermally Broken Stainless Steel Shelf Angle & Brick Ties Supporting Brick Veneer and R-12 Batt Insulation in Stud Cavity – Slab Intersection

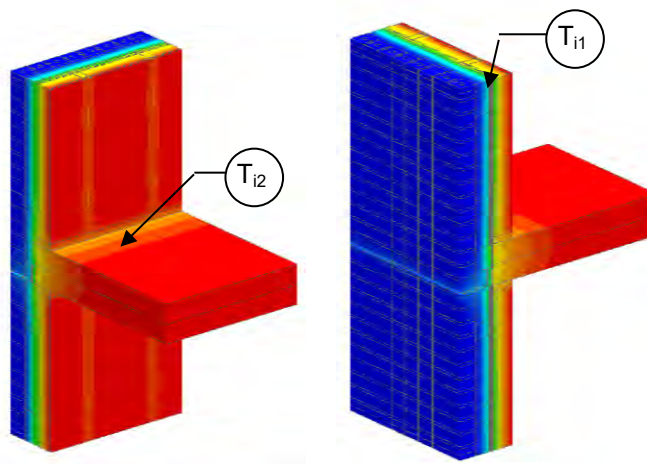

View from Interior

View from Exterior

Thermal Performance Indicators

Assembly 1D (Nominal) R-Value	R_{1D}	R-15.3 (2.70 RSI) + exterior insulation
Transmittance / Resistance without Anomaly	U_o, R_o	“clear wall” U- and R-value without slab and shelf angle
Transmittance / Resistance	U, R	U- and R-values for overall assembly
Surface Temperature Index	T_i	0 = exterior temperature 1 = interior temperature
Linear Transmittance	ψ	Incremental increase in transmittance per linear length of slab with shelf angle

¹Assumptions and limitations for surface temperatures identified in ASHRAE 1365-RP

Nominal (1D) vs. Assembly Performance Indicators

Exterior Insulation 1D R-Value (RSI)	R_{1D} ft ² ·hr·°F / Btu (m ² K / W)	R_o ft ² ·hr·°F / Btu (m ² K / W)	U_o Btu/ft ² ·hr ·°F (W/m ² K)	R ft ² ·hr·°F / Btu (m ² K / W)	U Btu/ft ² ·hr ·°F (W/m ² K)	ψ Btu/ft hr °F (W/m K)
R-5 (0.88)	R-20.3 (3.58)	R-13.9 (2.45)	0.072 (0.41)	R-9.2 (1.62)	0.109 (0.62)	0.228 (0.394)
R-10 (1.76)	R-25.3 (4.46)	R-17.0 (3.00)	0.059 (0.33)	R-12.8 (2.26)	0.078 (0.44)	0.119 (0.206)
R-15 (2.64)	R-30.3 (5.34)	R-19.8 (3.48)	0.051 (0.29)	R-14.5 (2.55)	0.069 (0.39)	0.114 (0.198)
R-20 (3.52)	R-35.3 (6.22)	R-22.5 (3.96)	0.045 (0.25)	R-16.0 (2.82)	0.062 (0.35)	0.111 (0.193)
R-25 (4.40)	R-40.3 (7.10)	R-24.9 (4.38)	0.040 (0.23)	R-17.4 (3.07)	0.057 (0.33)	0.107 (0.185)

Temperature Indices

	R5	R15	R25	
T_{i1}	0.40	0.60	0.69	Min T on sheathing, cavity centre away from slab
T_{i2}	0.73	0.84	0.87	Max T on sheathing, at slab, between steel studs

Detail 5.2.50

Exterior and Interior Insulated Wall Assembly with Stainless Steel Spaced Shelf Angle Without Flashing & Brick Ties Supporting Brick Veneer – Intermediate Floor Intersection

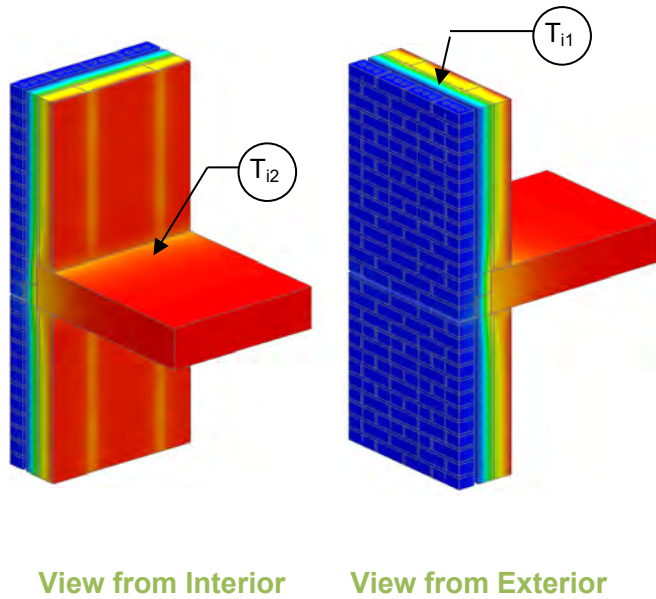

Thermal Performance Indicators

1.00	<table border="1"> <tr> <td>Assembly 1D (Nominal) R-Value</td> <td>R_{1D}</td> <td>R-15.3 (2.70 RSI) + exterior insulation</td> </tr> <tr> <td>Transmittance / Resistance without Anomaly</td> <td>U_o, R_o</td> <td>“clear wall” U- and R-value without slab and shelf angle</td> </tr> <tr> <td>Transmittance / Resistance</td> <td>U, R</td> <td>U- and R-values for overall assembly</td> </tr> <tr> <td>Surface Temperature Index¹</td> <td>T_i</td> <td>0 = exterior temperature 1 = interior temperature</td> </tr> <tr> <td>Linear Transmittance</td> <td>ψ</td> <td>Incremental increase in transmittance per linear length of shelf angle and slab</td> </tr> </table>	Assembly 1D (Nominal) R-Value	R_{1D}	R-15.3 (2.70 RSI) + exterior insulation	Transmittance / Resistance without Anomaly	U_o, R_o	“clear wall” U- and R-value without slab and shelf angle	Transmittance / Resistance	U, R	U- and R-values for overall assembly	Surface Temperature Index ¹	T_i	0 = exterior temperature 1 = interior temperature	Linear Transmittance	ψ	Incremental increase in transmittance per linear length of shelf angle and slab	0.90
Assembly 1D (Nominal) R-Value		R_{1D}	R-15.3 (2.70 RSI) + exterior insulation														
Transmittance / Resistance without Anomaly		U_o, R_o	“clear wall” U- and R-value without slab and shelf angle														
Transmittance / Resistance		U, R	U- and R-values for overall assembly														
Surface Temperature Index ¹		T_i	0 = exterior temperature 1 = interior temperature														
Linear Transmittance	ψ	Incremental increase in transmittance per linear length of shelf angle and slab															
0.80	0.70																
0.70	0.60																
0.60	0.50																
0.50	0.40																
0.40	0.30																
0.30	0.20																
0.20	0.10																
0.10	0.00																

¹Assumptions and limitations for surface temperatures identified in ASHRAE 1365-RP

Nominal (1D) vs. Assembly Performance Indicators

Exterior Insulation 1D R-Value (RSI)	R_{1D} ft ² ·hr·°F / Btu (m ² K / W)	R_o ft ² ·hr·°F / Btu (m ² K / W)	U_o Btu/ft ² ·hr·°F (W/m ² K)	R ft ² ·hr·°F / Btu (m ² K / W)	U Btu/ft ² ·hr·°F (W/m ² K)	ψ Btu/ft hr °F (W/m K)
R-5 (0.88)	R-20.3 (3.58)	R-13.9 (2.45)	0.072 (0.41)	R-11.0 (1.94)	0.091 (0.51)	0.116 (0.201)
R-10 (1.76)	R-25.3 (4.46)	R-17.0 (3.00)	0.059 (0.33)	R-13.7 (2.42)	0.073 (0.41)	0.088 (0.151)
R-15 (2.64)	R-30.3 (5.34)	R-19.8 (3.48)	0.051 (0.29)	R-15.8 (2.79)	0.063 (0.36)	0.078 (0.135)
R-20 (3.52)	R-35.3 (6.22)	R-22.5 (3.96)	0.045 (0.25)	R-18.1 (3.19)	0.055 (0.31)	0.066 (0.114)
R-25 (4.40)	R-40.3 (7.10)	R-24.9 (4.39)	0.040 (0.23)	R-20.1 (3.54)	0.050 (0.28)	0.059 (0.103)

Temperature Indices

	R5	R15	R25	
T_{i1}	0.40	0.60	0.69	Min T on sheathing, cavity centre away from slab
T_{i2}	0.66	0.76	0.84	Max T on sheathing, at slab, at steel studs

Detail 5.2.51

Exterior Insulated 6" x 1 5/8" Steel Stud (16" o.c.) Wall Assembly with U-Kon ND 0-33 Bracket and Vertical Rail System Supporting Metal Cladding – Intermediate Floor Intersection

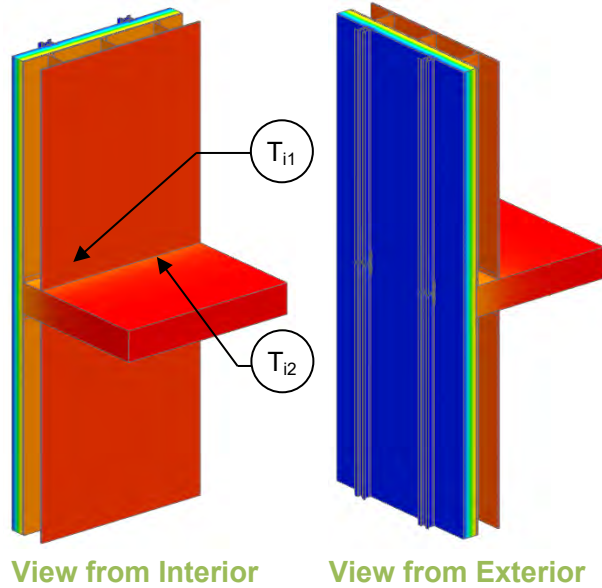

Thermal Performance Indicators

Assembly 1D (Nominal) R-Value	R_{1D}	R-3.30 (0.58 RSI) + exterior insulation
Transmittance / Resistance without Anomaly	U_o, R_o	“Clear wall” U- and R-value (including rails)
Transmittance / Resistance	U, R	U- and R-values for overall assembly
Surface Temperature Index ¹	T_i	0 = exterior temperature 1 = interior temperature
Linear Transmittance	ψ	Incremental increase in transmittance per linear length of slab
Point Transmittance	χ	Incremental increase in transmittance per bracket

¹Assumptions and limitations for surface temperature identified in ASHRAE 1365-RP

Nominal (1D) vs. Assembly Performance Indicators

24" Horizontal Bracket Spacing

Exterior Insulation 1D R-Value (RSI)	R_{1D} ft ² ·hr·°F / Btu (m ² K / W)	R_o ft ² ·hr·°F / Btu (m ² K / W)	U_o Btu/ft ² ·hr ·°F (W/m ² K)	R ft ² ·hr·°F / Btu (m ² K / W)	U Btu/ft ² ·hr ·°F (W/m ² K)	ψ Btu/ft ·hr ·°F (W/m K)	χ Btu/ ·hr ·°F (W/ K)
R-12.6 (2.22)	R-15.9 (2.80)	R-15.5 (2.73)	0.064 (0.37)	R-14.6 (2.57)	0.068 (0.39)	0.000 (0.000)	0.079 (0.042)
R-16.8 (2.96)	R-20.1 (3.54)	R-19.6 (3.44)	0.051 (0.29)	R-18.2 (3.21)	0.055 (0.31)	0.003 (0.006)	0.067 (0.036)
R-21.0 (3.70)	R-24.3 (4.28)	R-23.6 (4.15)	0.042 (0.24)	R-21.9 (3.85)	0.046 (0.26)	0.002 (0.004)	0.061 (0.032)
R-25.2 (4.44)	R-28.5 (5.02)	R-27.9 (4.92)	0.036 (0.20)	R-25.8 (4.54)	0.039 (0.22)	0.002 (0.003)	0.057 (0.030)
R-42.0 (7.40)	R-45.3 (7.98)	R-44.7 (7.87)	0.022 (0.13)	R-40.5 (7.13)	0.025 (0.14)	0.001 (0.001)	0.045 (0.024)

30" Horizontal Bracket Spacing

Exterior Insulation 1D R-Value (RSI)	R_{1D} ft ² ·hr·°F / Btu (m ² K / W)	R_o ft ² ·hr·°F / Btu (m ² K / W)	U_o Btu/ft ² ·hr ·°F (W/m ² K)	R ft ² ·hr·°F / Btu (m ² K / W)	U Btu/ft ² ·hr ·°F (W/m ² K)	ψ Btu/ft ·hr ·°F (W/m K)	χ Btu/ ·hr ·°F (W/ K)
R-12.6 (2.22)	R-15.9 (2.80)	R-15.6 (2.74)	0.064 (0.37)	R-14.8 (2.61)	0.067 (0.38)	0.006 (0.010)	0.066 (0.035)
R-16.8 (2.96)	R-20.1 (3.54)	R-19.6 (3.46)	0.051 (0.29)	R-18.6 (3.27)	0.054 (0.31)	0.003 (0.006)	0.065 (0.035)
R-21.0 (3.70)	R-24.3 (4.28)	R-23.7 (4.17)	0.042 (0.24)	R-22.3 (3.92)	0.045 (0.26)	0.002 (0.004)	0.062 (0.033)
R-25.2 (4.44)	R-28.5 (5.02)	R-28.0 (4.93)	0.036 (0.20)	R-26.2 (4.62)	0.038 (0.22)	0.002 (0.003)	0.057 (0.030)
R-42.0 (7.40)	R-45.3 (7.98)	R-44.8 (7.89)	0.022 (0.13)	R-41.6 (7.33)	0.024 (0.14)	0.001 (0.001)	0.041 (0.022)

Temperature Indices

Bracket Spacing		R-12.6	R-16.8	R-21.0	R-25.2	R-42.0	
24"	T_{i1}	0.86	0.89	0.90	0.91	0.94	Min T on sheathing, at slab, between studs
	T_{i2}	0.93	0.95	0.95	0.96	0.97	Min T on slab, at gypsum
30"	T_{i1}	0.86	0.89	0.90	0.91	0.95	Min T on sheathing, at slab, between studs
	T_{i2}	0.93	0.95	0.96	0.96	0.97	Min T on slab, at gypsum

Detail 5.3.1

Exterior Insulated 3 5/8" x 1 5/8" Steel Stud (16" o.c.) Drained EIFS Wall Assembly – Window and Intermediate Floor Intersection

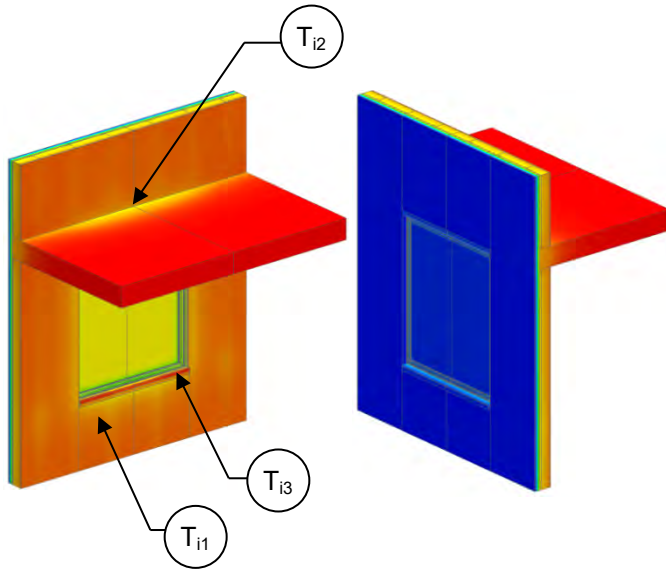

View from Interior

View from Exterior

Thermal Performance Indicators

Assembly 1D (Nominal) R-Value	R_{1D}	R-2.7 (0.47 RSI) + exterior insulation
Transmittance / Resistance without Anomaly	U_o, R_o	"clear wall" U- and R-value, without slab and window
Transmittance / Resistance	U_s, R_s, U_g	U and R-values for s = wall + slab g = glazing
Transmittance / Resistance	U, R	U- and R-values for overall assembly
Surface Temperature Index ¹	T_i	0 = exterior temperature 1 = interior temperature
Linear Transmittance	ψ_s, ψ_g	Incremental increase in transmittance per linear length of s = slab g = glazing transition

¹Assumptions and limitations for surface temperatures identified in ASHRAE 1365-RP

Nominal (1D) vs. Assembly Performance Indicators

Base Assembly – Wall

Exterior Insulation 1D R-Value (RSI)	R_{1D} ft ² ·hr·°F / Btu (m ² K / W)	R_o ft ² ·hr·°F / Btu (m ² K / W)	U_o Btu/ft ² ·hr·°F (W/m ² K)
R-7.5 (1.32)	R-10.2 (1.80)	R-10.0 (1.76)	0.100 (0.57)
R-11.3 (1.98)	R-13.9 (2.46)	R-13.7 (2.41)	0.073 (0.41)
R-15 (2.64)	R-17.7 (3.12)	R-17.4 (3.06)	0.057 (0.33)

Base Assembly - Glazing

$U_{\text{centre of glazing}}$ Btu/ft ² ·hr·°F (W/m ² K)	U_g Btu/ft ² ·hr·°F (W/m ² K)
0.321 (1.82)	0.400 (2.27)

Window Transition Linear Transmittance

Exterior Insulation 1D R-Value (RSI)	R ft ² ·hr·°F / Btu (m ² K / W)	U Btu/ft ² ·hr·°F (W/m ² K)	ψ_g^2 Btu/ft ² ·hr·°F (W/m K)
R-7.5 (1.32)	R-4.8 (0.84)	0.210 (1.19)	0.160 (0.277)
R-11.3 (1.98)	R-5.2 (0.92)	0.192 (1.09)	0.175 (0.303)
R-15 (2.64)	R-5.5 (0.97)	0.182 (1.03)	0.187 (0.324)

Slab Linear Transmittance

R_s ft ² ·hr·°F / Btu (m ² K / W)	U_s Btu/ft ² ·hr·°F (W/m ² K)	ψ_s Btu/ft ² ·hr·°F (W/m ² K)
R-9.7 (1.70)	0.104 (0.59)	0.032 (0.055)
R-13.3 (2.35)	0.075 (0.43)	0.018 (0.032)
R-17.0 (2.99)	0.059 (0.33)	0.012 (0.022)

Temperature Indices

	R7.5	R11.3	R15	
T_{i1}	0.33	0.33	0.34	Min T on sheathing, below window sill
T_{i2}	0.86	0.89	0.91	Max T on sheathing, at slab intersection away from window
T_{i3}	0.55	0.56	0.56	Min T on window frame, at corner of window at glass

²For the linear transmittance, use the window perimeter



Detail 5.3.2

Exterior and Interior Insulated 3 5/8" x 1 5/8" Steel Stud (16" o.c.) Drained EIFS Wall Assembly with R-12 Batt Insulation in Stud Cavity – Window and Intermediate Floor Intersection

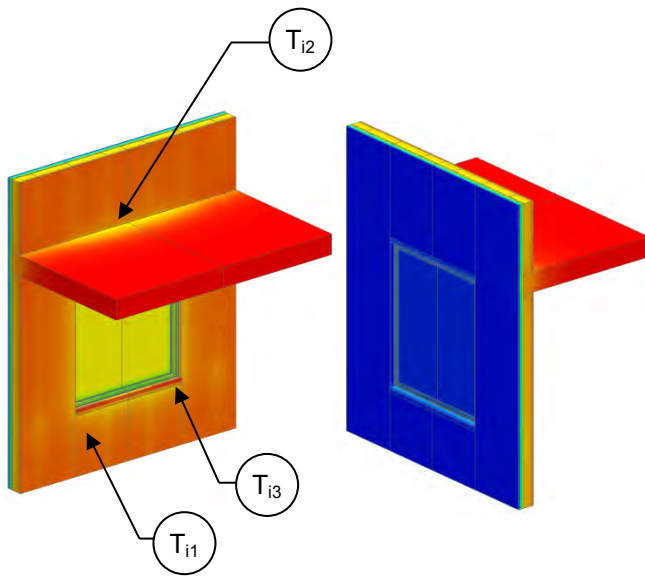

View from Interior

View from Exterior

Thermal Performance Indicators

Assembly 1D (Nominal) R-Value	R _{1D}	R-14.2 (2.51 RSI) + exterior insulation
Transmittance / Resistance without Anomaly	U _o , R _o	"clear wall" U- and R-value, without slab and window
Transmittance / Resistance	U _s , R _s , U _g	U and R-values for s = wall + slab g = glazing
Transmittance / Resistance	U, R	U- and R-values for overall assembly
Surface Temperature Index ¹	T _i	0 = exterior temperature 1 = interior temperature
Linear Transmittance	ψ _s , ψ _g	Incremental increase in transmittance per linear length of s = slab g = glazing transition

¹Assumptions and limitations for surface temperatures identified in ASHRAE 1365-RP

Nominal (1D) vs. Assembly Performance Indicators

Base Assembly – Wall

Exterior Insulation 1D R-Value (RSI)	R _{1D} ft ² ·hr·°F / Btu (m ² K / W)	R _o ft ² ·hr·°F / Btu (m ² K / W)	U _o Btu/ft ² ·hr·°F (W/m ² K)
R-7.5 (1.32)	R-21.7 (3.83)	R-16.6 (2.93)	0.060 (0.34)
R-15 (2.64)	R-29.2 (5.15)	R-24.0 (4.23)	0.042 (0.24)

Base Assembly - Glazing

U _{centre of glazing} Btu/ft ² ·hr·°F (W/m ² K)	U _g Btu/ft ² ·hr·°F (W/m ² K)
0.321 (1.82)	0.400 (2.27)

Window Transition Linear Transmittance

Exterior Insulation 1D R-Value (RSI)	R ft ² ·hr·°F / Btu (m ² K / W)	U Btu/ft ² ·hr·°F (W/m ² K)	ψ _g ² Btu/ft ² ·hr·°F (W/m K)
R-7.5 (1.32)	R-5.6 (0.98)	0.180 (1.02)	0.136 (0.236)
R-15 (2.64)	R-6.1 (1.07)	0.165 (0.94)	0.155 (0.268)

Slab Linear Transmittance

R _s ft ² ·hr·°F / Btu (m ² K / W)	U _s Btu/ft ² ·hr·°F (W/m ² K)	ψ _s Btu/ft ² ·hr·°F (W/m ² K)
R-14.5 (2.55)	0.069 (0.39)	0.076 (0.132)
R-22.0 (3.88)	0.045 (0.26)	0.032 (0.056)

Temperature Indices

	R7.5	R15	
T _{i1}	0.25	0.26	Min T on sheathing, below window sill between studs
T _{i2}	0.84	0.89	Max T on sheathing, along steel tracks at slab
T _{i3}	0.52	0.53	Min T on window frame, at corner of window at glass

²For the linear transmittance, use the window perimeter

Detail 5.3.3

Exterior Insulated 3 5/8" x 1 5/8" Steel Stud (16" o.c.) Drained EIFS Wall Assembly – Window with Aerogel and Intermediate Floor Intersection

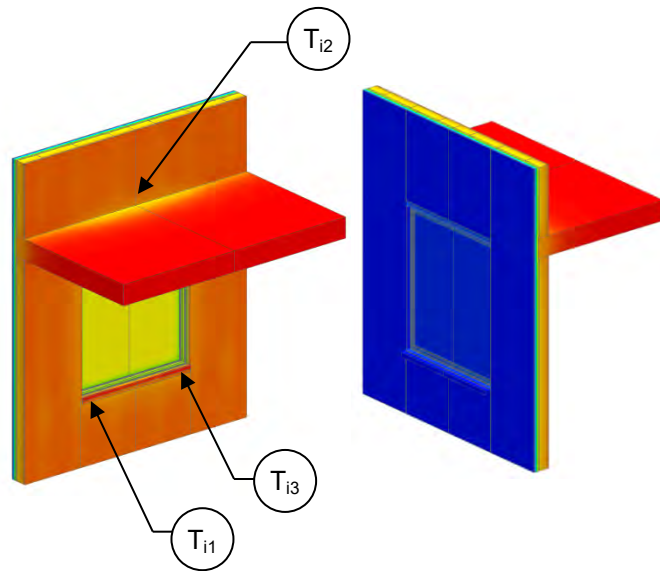

View from Interior

View from Exterior

Thermal Performance Indicators

Assembly 1D (Nominal) R-Value	R_{1D}	R-2.7 (0.47 RSI) + exterior insulation
Transmittance / Resistance without Anomaly	U_o, R_o	“clear wall” U- and R-value, without slab and window
Transmittance / Resistance	U_s, R_s, U_g	U and R-values for s = wall + slab g = glazing
Transmittance / Resistance	U, R	U- and R-values for overall assembly
Surface Temperature Index ¹	T_i	0 = exterior temperature 1 = interior temperature
Linear Transmittance	ψ_s, ψ_g	Incremental increase in transmittance per linear length of s = slab g = glazing transition

¹Assumptions and limitations for surface temperatures identified in ASHRAE 1365-RP

Nominal (1D) vs. Assembly Performance Indicators

Base Assembly – Wall

Exterior Insulation 1D R-Value (RSI)	R_{1D} ft ² ·hr·°F / Btu (m ² K / W)	R_o ft ² ·hr·°F / Btu (m ² K / W)	U_o Btu/ft ² ·hr ·°F (W/m ² K)
R-7.5 (1.32)	R-10.2 (1.80)	R-10.0 (1.76)	0.100 (0.57)
R-11.3 (1.98)	R-13.9 (2.46)	R-13.7 (2.41)	0.073 (0.41)
R-15 (2.64)	R-17.7 (3.12)	R-17.4 (3.06)	0.057 (0.33)

Base Assembly - Glazing

$U_{\text{centre of glazing}}$ Btu/ft ² ·hr ·°F (W/m ² K)	U_g Btu/ft ² ·hr ·°F (W/m ² K)
0.321 (1.82)	0.400 (2.27)

Window Transition Linear Transmittance

Exterior Insulation 1D R-Value (RSI)	R ft ² ·hr·°F / Btu (m ² K / W)	U Btu/ft ² ·hr ·°F (W/m ² K)	ψ_g^2 Btu/ft ² ·hr ·°F (W/m K)
R-7.5 (1.32)	R-5.1 (0.90)	0.196 (1.11)	0.093 (0.160)
R-11.3 (1.98)	R-5.7 (1.00)	0.176 (1.00)	0.103 (0.178)
R-15 (2.64)	R-6.0 (1.06)	0.166 (0.94)	0.112 (0.194)

Slab Linear Transmittance

R_s ft ² ·hr·°F / Btu (m ² K / W)	U_s Btu/ft ² ·hr ·°F (W/m ² K)	ψ_s Btu/ft ² ·hr ·°F (W/m ² K)
R-9.7 (1.70)	0.104 (0.59)	0.032 (0.055)
R-13.3 (2.35)	0.075 (0.43)	0.018 (0.032)
R-17.0 (2.99)	0.059 (0.33)	0.012 (0.022)

Temperature Indices

	R7.5	R11.3	R15	
T_{i1}	0.60	0.62	0.63	Min T on sheathing, below window sill
T_{i2}	0.87	0.90	0.92	Max T on sheathing, at slab intersection away from window
T_{i3}	0.59	0.59	0.59	Min T on window frame, at corner of window at glass

²For the linear transmittance, use the window perimeter



Detail 5.3.4

Exterior and Interior Insulated 3 5/8" x 1 5/8" Steel Stud (16" o.c.) Drained EIFS Wall Assembly with R-12 Batt Insulation in Stud Cavity – Window with Aerogel and Intermediate Floor Intersection

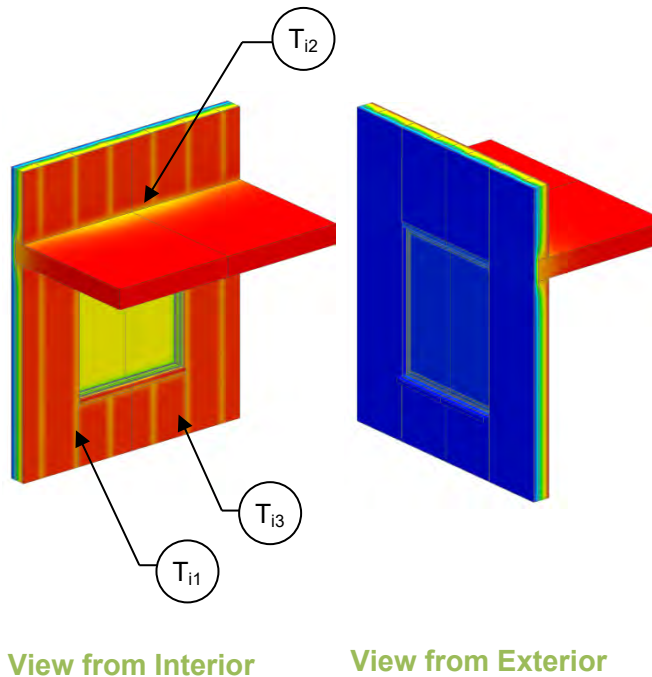

Thermal Performance Indicators

Assembly 1D (Nominal) R-Value	R_{1D}	R-14.2 (2.51 RSI) + exterior insulation
Transmittance / Resistance without Anomaly	U_o, R_o	“clear wall” U- and R-value, without slab and window
Transmittance / Resistance	U_s, R_s, U_g	U and R-values for s = wall + slab g = glazing
Transmittance / Resistance	U, R	U- and R-values for overall assembly
Surface Temperature Index ¹	T_i	0 = exterior temperature 1 = interior temperature
Linear Transmittance	ψ_s, ψ_g	Incremental increase in transmittance per linear length of s = slab g = glazing transition

¹Assumptions and limitations for surface temperatures identified in ASHRAE 1365-RP

Nominal (1D) vs. Assembly Performance Indicators

Base Assembly – Wall

Exterior Insulation 1D R-Value (RSI)	R_{1D} ft ² ·hr·°F / Btu (m ² K / W)	R_o ft ² ·hr·°F / Btu (m ² K / W)	U_o Btu/ft ² ·hr ·°F (W/m ² K)
R-7.5 (1.32)	R-21.7 (3.83)	R-16.6 (2.93)	0.060 (0.34)
R-15 (2.64)	R-29.2 (5.15)	R-24.0 (4.23)	0.042 (0.24)

Base Assembly - Glazing

$U_{\text{centre of glazing}}$ Btu/ft ² ·hr ·°F (W/m ² K)	U_g Btu/ft ² ·hr ·°F (W/m ² K)
0.321 (1.82)	0.400 (2.27)

Window Transition Linear Transmittance

Exterior Insulation 1D R-Value (RSI)	R ft ² ·hr·°F / Btu (m ² K / W)	U Btu/ft ² ·hr ·°F (W/m ² K)	ψ_g^2 Btu/ft hr °F (W/m K)
R-7.5 (1.32)	R-6.0 (1.05)	0.168 (0.95)	0.083 (0.144)
R-15 (2.64)	R-6.5 (1.15)	0.154 (0.87)	0.103 (0.178)

Slab Linear Transmittance

R_s ft ² ·hr·°F / Btu (m ² K / W)	U_s Btu/ft ² ·hr ·°F (W/m ² K)	ψ_s Btu/ft ² ·hr ·°F (W/m ² K)
R-14.5 (2.55)	0.069 (0.39)	0.076 (0.132)
R-22.0 (3.88)	0.045 (0.26)	0.032 (0.056)

Temperature Indices

	R7.5	R15	
T_{i1}	0.39	0.51	Min T on sheathing, below window sill between studs
T_{i2}	0.85	0.90	Max T on sheathing, along steel tracks at slab
T_{i3}	0.56	0.57	Min T on window frame, at corner of window at glass

²For the linear transmittance, use the window perimeter

Detail 5.3.5

Exterior Insulated 3 5/8" x 1 5/8" Steel Stud (16" o.c.) Wall Assembly with Horizontal Z-Girts (24" o.c.) Supporting Metal Cladding – Window & Slab Intersection

Thermal Performance Indicators

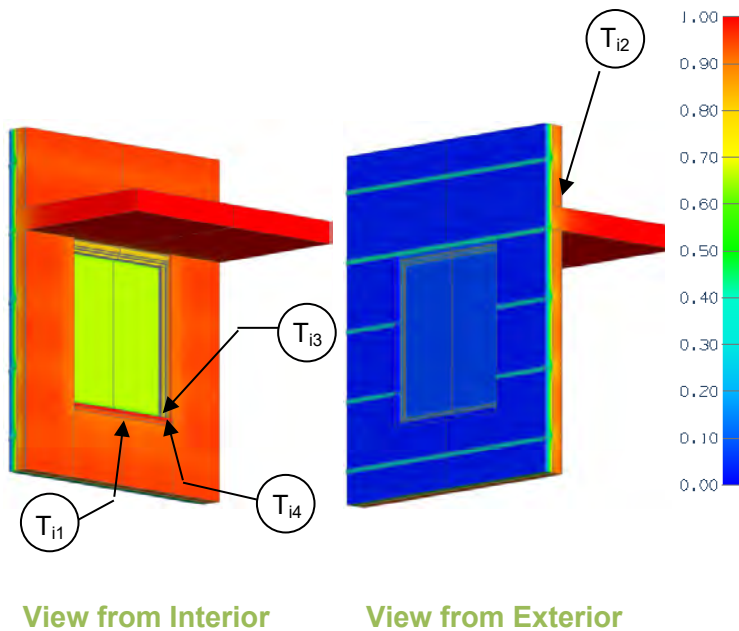

Assembly 1D (Nominal) R-Value	R_{1D}	R-3.2 (0.56 RSI) + horizontal exterior insulation
Transmittance / Resistance without Anomaly	U_o, R_o	“clear wall” U- and R-value, without slab and window
Transmittance / Resistance	U_s, R_s, U_g	U and R-values for s = wall + slab g = glazing
Transmittance / Resistance	U, R	U- and R-values for overall assembly
Surface Temperature Index ¹	T_i	0 = exterior temperature 1 = interior temperature
Linear Transmittance	ψ_s, ψ_g	Incremental increase in transmittance per linear length of s = slab g = glazing transition

¹Assumptions and limitations for surface temperatures identified in ASHRAE 1365-RP

Nominal (1D) vs. Assembly Performance Indicators

Base Assembly – Wall

Exterior Insulation 1D R-Value (RSI)	R_{1D} ft ² ·hr·°F / Btu (m ² K / W)	R_o ft ² ·hr·°F / Btu (m ² K / W)	U_o Btu/ft ² ·hr·°F (W/m ² K)
R-5 (0.88)	R-8.2 (1.44)	R-6.8 (1.21)	0.146 (0.83)
R-15 (2.64)	R-18.2 (3.20)	R-11.3 (1.99)	0.088 (0.50)
R-25 (4.40)	R-28.2 (4.96)	R-14.5 (2.56)	0.069 (0.39)

Base Assembly - Glazing

$U_{\text{centre of glazing}}$ Btu/ft ² ·hr·°F (W/m ² K)	U_g Btu/ft ² ·hr·°F (W/m ² K)
0.321 (1.82)	0.400 (2.27)

Window Transition Linear Transmittance

Exterior Insulation 1D R-Value (RSI)	R ft ² ·hr·°F / Btu (m ² K / W)	U Btu/ft ² ·hr·°F (W/m ² K)	ψ_g^2 Btu/ft ² ·hr·°F (W/m K)
R-5 (0.88)	R-6.0 (1.05)	0.168 (0.95)	0.044 (0.077)
R-15 (2.64)	R-9.0 (1.59)	0.111 (0.63)	0.062 (0.108)
R-25 (4.40)	R-10.9 (1.91)	0.092 (0.52)	0.069 (0.120)

Slab Linear Transmittance

R_s ft ² ·hr·°F / Btu (m ² K / W)	U_s Btu/ft ² ·hr·°F (W/m ² K)	ψ_s Btu/ft ² ·hr·°F (W/m ² K)
R-6.4 (1.13)	1.56 (0.89)	0.061 (0.106)
R-10.8 (1.90)	0.093 (0.53)	0.025 (0.044)
R-13.9 (2.45)	0.072 (0.41)	0.019 (0.034)

Temperature Indices

	R5	R15	R25	
T_{i1}	0.39	0.39	0.39	Min T on sheathing, interior surface at window sill, centre of cavity
T_{i2}	0.79	0.88	0.91	Max T on sheathing, at slab floor, at studs, away from window
T_{i3}	0.61	0.62	0.63	Min T on window frame, at bottom corner
T_{i4}	0.58	0.58	0.59	Min T on window glass, at bottom corner

²For the linear transmittance, use the window perimeter

Detail 5.3.6

Exterior and Interior Insulated 3 5/8" x 1 5/8" Steel Stud (16" o.c.) Wall Assembly with Horizontal Z-girts (24" o.c.) Supporting Metal Cladding and R-12 Batt Insulation in Stud Cavity – Window and Intermediate Floor Intersection

Thermal Performance Indicators

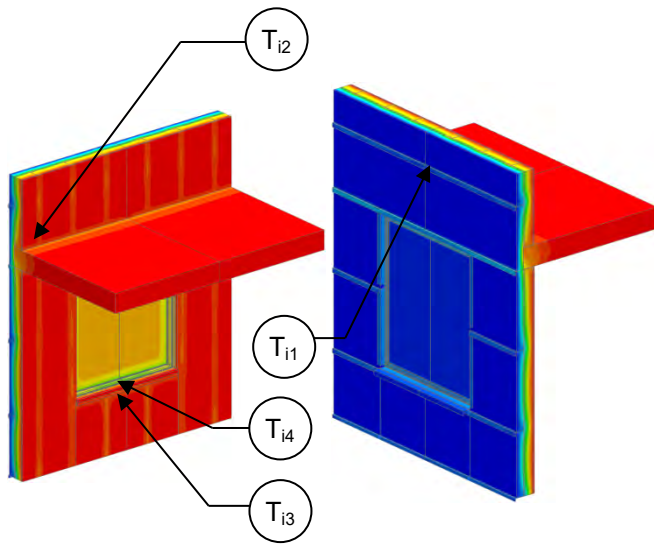

View from Interior

View from Exterior

Assembly 1D (Nominal) R-Value	R_{1D}	R-14.4 (2.54 RSI) + exterior insulation
Transmittance / Resistance without Anomaly	U_o, R_o	"clear wall" U- and R-value, without slab and window
Transmittance / Resistance	U_s, R_s, U_g	U and R-values for s = concrete wall + slab g = glazing
Transmittance / Resistance	U, R	U- and R-values for overall assembly
Surface Temperature Index ¹	T_i	0 = exterior temperature 1 = interior temperature
Linear Transmittance	ψ_s, ψ_g	Incremental increase in transmittance per linear length of s = slab g = glazing transition

¹Assumptions and limitations for surface temperatures identified in ASHRAE 1365-RP

Nominal (1D) vs. Assembly Performance Indicators

Base Assembly – Wall

Exterior Insulation 1D R-Value (RSI)	R_{1D} ft ² ·hr·°F / Btu (m ² K / W)	R_o ft ² ·hr·°F / Btu (m ² K / W)	U_o Btu/ft ² ·hr·°F (W/m ² K)
R-10 (1.76)	R-24.4 (4.30)	R-16.1 (2.83)	0.062 (0.35)
R-15 (2.64)	R-29.4 (5.18)	R-18.5 (3.26)	0.054 (0.31)

Base Assembly - Glazing

$U_{\text{centre of glass}}$ Btu/ft ² ·hr·°F (W/m ² K)	U_g Btu/ft ² ·hr·°F (W/m ² K)
0.321 (1.82)	0.400 (2.27)

Window Transition Linear Transmittance

Exterior Insulation 1D R-Value (RSI)	R ft ² ·hr·°F / Btu (m ² K / W)	U Btu/ft ² ·hr·°F (W/m ² K)	ψ_g^2 Btu/ft·hr·°F (W/m K)
R-10 (1.76)	R-5.8 (1.02)	0.173 (0.98)	0.113 (0.196)
R-15 (2.64)	R-5.8 (1.03)	0.171 (0.97)	0.130 (0.225)

Slab Linear Transmittance

R_s ft ² ·hr·°F / Btu (m ² K / W)	U_s Btu/ft ² ·hr·°F (W/m ² K)	ψ_s Btu/ft ² ·hr·°F (W/m ² K)
R-12 (2.19)	0.080 (0.46)	0.109 (0.188)
R-14 (2.53)	0.069 (0.39)	0.092 (0.160)

Temperature Indices

	R10	R15	
T_{i1}	0.24	0.26	Min T on sheathing, between studs at girts, away from window
T_{i2}	0.81	0.83	Max T on sheathing, at slab floor, at studs, away from window
T_{i3}	0.61	0.61	Min T on window frame, at bottom edge of glazing
T_{i4}	0.61	0.60	Min T on window glass, at bottom edge

²For the linear transmittance, use the window perimeter

Detail 5.3.7

Exterior and Interior Insulated 3 5/8" x 1 5/8" Steel Stud (16" o.c.) Wall Assembly with Vertical Z Girts (16" o.c.) Supporting Stucco Cladding and R-12 Batt Insulation in Stud Cavity – Window and Intermediate Floor Intersection

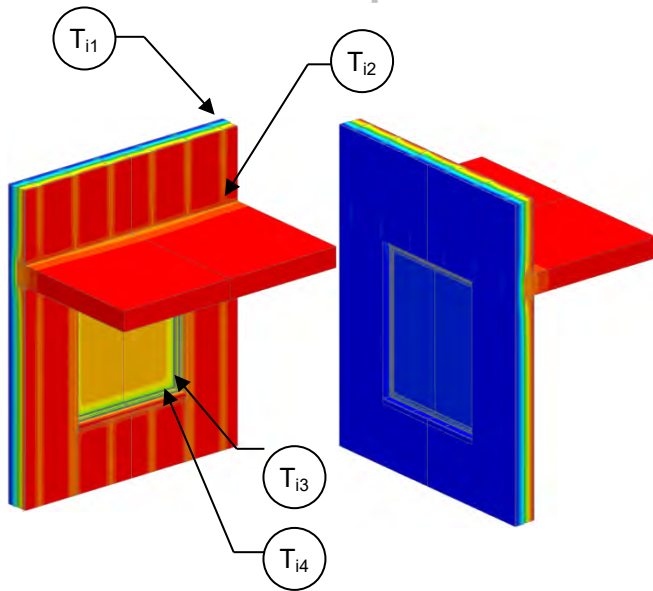

View from Interior

View from Exterior

Thermal Performance Indicators

Assembly 1D (Nominal) R-Value	R_{1D}	R-14.5 (2.55 RSI) + exterior insulation
Transmittance / Resistance without Anomaly	U_o, R_o	"clear wall" U- and R-value, without slab and window
Transmittance / Resistance	U_s, R_s, U_g	U and R-values for s = concrete wall + slab g = glazing
Transmittance / Resistance	U, R	U- and R-values for overall assembly
Surface Temperature Index ¹	T_i	0 = exterior temperature 1 = interior temperature
Linear Transmittance	ψ_s, ψ_g	Incremental increase in transmittance per linear length of s = slab g = glazing transition

¹Assumptions and limitations for surface temperatures identified in ASHRAE 1365-RP

Nominal (1D) vs. Assembly Performance Indicators

Base Assembly – Wall

Exterior Insulation 1D R-Value (RSI)	R_{1D} ft ² ·hr·°F / Btu (m ² K / W)	R_o ft ² ·hr·°F / Btu (m ² K / W)	U_o Btu/ft ² ·hr·°F (W/m ² K)
R-10 (1.76)	R-24.5 (4.31)	R-13.0 (2.29)	0.077 (0.44)
R-15 (2.64)	R-29.5 (5.20)	R-14.1 (2.49)	0.071 (0.40)

Base Assembly - Glazing

$U_{\text{centre of glass}}$ Btu/ft ² ·hr·°F (W/m ² K)	U_g Btu/ft ² ·hr·°F (W/m ² K)
0.321 (1.82)	0.400 (2.27)

Window Transition Linear Transmittance

Exterior Insulation 1D R-Value (RSI)	R ft ² ·hr·°F / Btu (m ² K / W)	U Btu/ft ² ·hr·°F (W/m ² K)	ψ_g^2 Btu/ft ² ·hr·°F (W/m K)
R-10 (1.76)	R-5.5 (0.96)	0.183 (1.04)	0.074 (0.128)
R-15 (2.64)	R-6.6 (0.99)	0.179 (1.01)	0.081 (0.140)

Slab Linear Transmittance

R_s ft ² ·hr·°F / Btu (m ² K / W)	U_s Btu/ft ² ·hr·°F (W/m ² K)	ψ_s Btu/ft ² ·hr·°F (W/m ² K)
R-11.5 (2.02)	0.087 (0.50)	0.090 (0.155)
R-12.6 (2.22)	0.079 (0.45)	0.075 (0.129)

Temperature Indices

	R10	R15	
T_{i1}	0.34	0.38	Min T on sheathing, along studs behind girt away from window/slab
T_{i2}	0.79	0.81	Max T on sheathing, at slab floor, between studs, away from window
T_{i3}	0.59	0.59	Min T on window frame, at bottom corner
T_{i4}	0.58	0.58	Min T on window glass, at corners

²For the linear transmittance, use the window perimeter

Detail 5.3.8

Interior Insulated Steel Frame Wall Assembly with Brick Cladding - Window Intersection

Detail referenced from work done by Passive House Academy

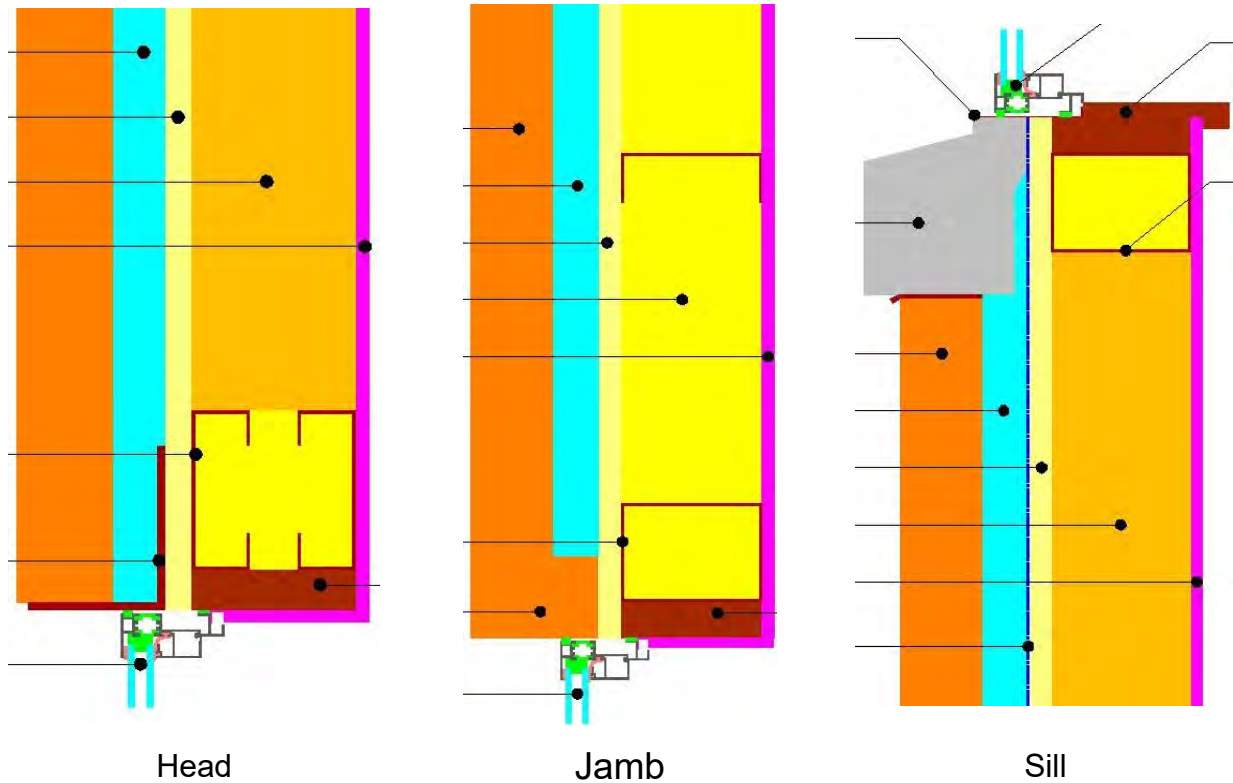

Thermal Performance

Condition	Clear Wall R-Value ft ² ·hr·°F / Btu (m ² K / W)	Clear Wall U-Value Btu / ft ² ·hr·°F (W/m ² K)	Linear Transmittance (Ψ) Btu/hr ft F (W/m K)
Wall Clear Field	R-22.6 (3.98)	0.044 (0.251)	-
Typical Jamb			0.110 (0.191)
Typical Head			0.143 (0.247)
Typical Sill			0.278 (0.481)
Typical Overall Window			0.160 (0.278)

Detail 5.3.9

Interior Insulated Steel Frame Wall Assembly with Brick Cladding - Window Intersection Aligned with Insulation

Detail referenced from work done by Passive House Academy

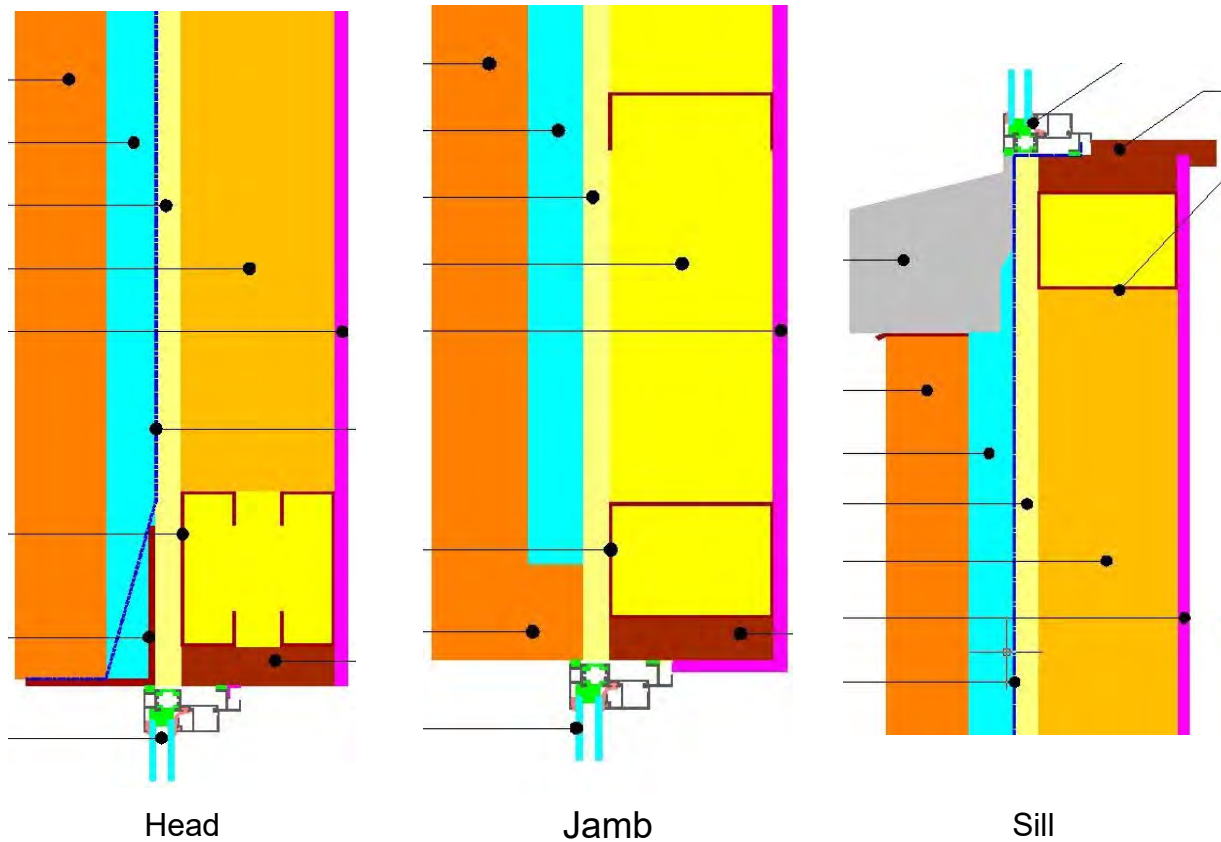

Thermal Performance

Condition	Clear Wall R-Value ft ² ·hr·°F / Btu (m ² K / W)	Clear Wall U-Value Btu/ ft ² ·hr·°F (W/m ² K)	Linear Transmittance (Ψ) Btu/hr ft °F (W/m K)
Wall Clear Field	R-22.6 (3.98)	0.044 (0.251)	-
Aligned Jamb			0.056 (0.097)
Aligned Head			0.044 (0.077)
Aligned Sill			0.057 (0.098)
Aligned Overall Window			0.053 (0.092)

Detail 5.3.10

Exterior Insulated 6" x 1 5/8" Steel Stud (16" o.c.) Wall Assembly with Thermally Isolated Vertical Brackets and Rail System (24" o.c.) Supporting Metal Cladding – Triple Glazed Aluminum Window & Intermediate Floor Intersection with Window Thermal Break Positioned in Steel Framing

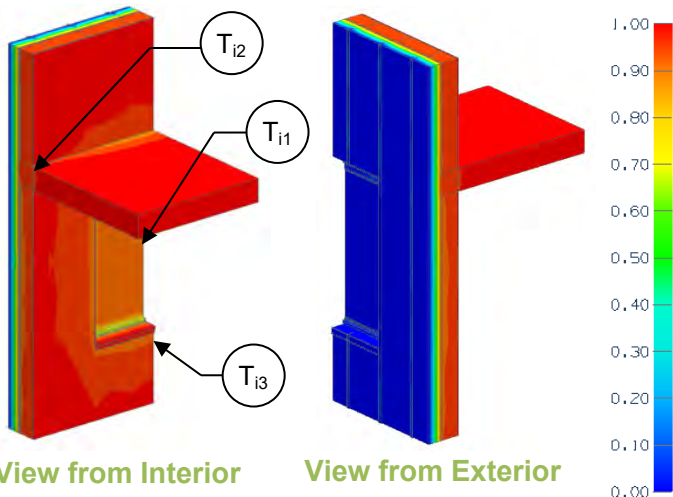

Thermal Performance Indicators

Assembly 1D (Nominal) R-Value	R _{1D}	R-3.2 (0.56 RSI) + exterior insulation
Transmittance / Resistance without Anomaly	U _w , R _w , U _g	"clear wall" U- and R-value: w = wall without intermediate floor g = glazing
Transmittance / Resistance	U _{floor} , R _{floor} , U _t , R _t	U and R-values for: floor = wall + intermediate floor t = combined wall + floor + window
Surface Temperature Index ¹	T _i	0 = exterior temperature 1 = interior temperature
Linear Transmittance	ψ	Incremental increase in transmittance per linear length

¹Assumptions and limitations for surface temperatures identified in ASHRAE 1365-RP

Base Assembly – Glazing

U _{centre of glass} Btu/ft ² · hr · °F (W/m ² K)	U _g Btu/ft ² · hr · °F (W/m ² K)
0.142 (0.81)	0.303 (1.72)

Nominal (1D) vs. Assembly Performance Indicators

Base Assembly – Steel Stud Clear Wall

Exterior Insulation 1D R-Value (RSI)	R _{1D} ft ² ·hr·°F / Btu (m ² K / W)	R _w ft ² ·hr·°F / Btu (m ² K / W)	U _w Btu/ft ² · hr · °F (W/m ² K)
R-10 (1.76)	R-13.2 (2.32)	R-11.2 (1.97)	0.090 (0.51)
R-15 (2.64)	R-18.2 (3.20)	R-13.9 (2.45)	0.072 (0.41)
R-20 (3.52)	R-23.2 (4.08)	R-16.9 (2.98)	0.059 (0.34)
R-25 (4.40)	R-28.2 (4.96)	R-19.7 (3.48)	0.051 (0.29)

Intermediate Floor Linear Transmittance

R _{floor} ft ² ·hr·°F / Btu (m ² K / W)	U _{floor} Btu/ft ² · hr · °F (W/m ² K)	ψ _{floor} Btu/ft ² · hr · °F (W/m ² K)
R-10.6 (1.88)	0.094 (0.53)	0.030 (0.052)
R-13.2 (2.32)	0.076 (0.43)	0.029 (0.051)
R-15.9 (2.81)	0.063 (0.36)	0.026 (0.045)
R-18.5 (3.27)	0.054 (0.31)	0.023 (0.040)

Window Transition Transmittance

Exterior Insulation 1D R-Value (RSI)	R _t ft ² ·hr·°F / Btu (m ² K / W)	U _t Btu/ft ² · hr · °F (W/m ² K)	ψ _{Head} Btu/ft ² · hr · °F (W/m K)	ψ _{Sill} Btu/ft ² · hr · °F (W/m K)	ψ _{Jamb} Btu/ft ² · hr · °F (W/m K)	ψ _{Total} Btu/ft ² · hr · °F (W/m K)
R-10 (1.76)	R-6.0 (1.06)	0.166 (0.95)	0.259 (0.448)	0.111 (0.192)	0.102 (0.176)	0.137 (0.238)
R-15 (2.64)	R-6.4 (1.14)	0.155 (0.88)	0.270 (0.467)	0.122 (0.211)	0.110 (0.190)	0.151 (0.261)
R-20 (3.52)	R-6.8 (1.20)	0.147 (0.83)	0.280 (0.484)	0.129 (0.223)	0.115 (0.199)	0.159 (0.275)
R-25 (4.40)	R-7.1 (1.25)	0.141 (0.80)	0.315 (0.545)	0.133 (0.231)	0.120 (0.208)	0.167 (0.289)

Temperature Indices

	R10	R15	R20	R25	
T _{i1}	0.44	0.44	0.44	0.44	Min T on window frame, centre of window head
T _{i2}	0.84	0.87	0.89	0.90	Max T on interior surface of sheathing, along bottom track
T _{i3}	0.58	0.58	0.59	0.60	Min T on interior surface of sheathing, along window sill track



Detail 5.3.11

Exterior and Interior Insulated 6" x 1 5/8" Steel Stud (16" o.c.) Wall Assembly with Thermally Isolated Vertical Brackets and Rail System (24" o.c.) Supporting Metal Cladding and R-19 Batt Insulation in Stud Cavity – Triple Glazed Aluminum Window & Intermediate Floor Intersection with Window Thermal Break Positioned in Steel Framing

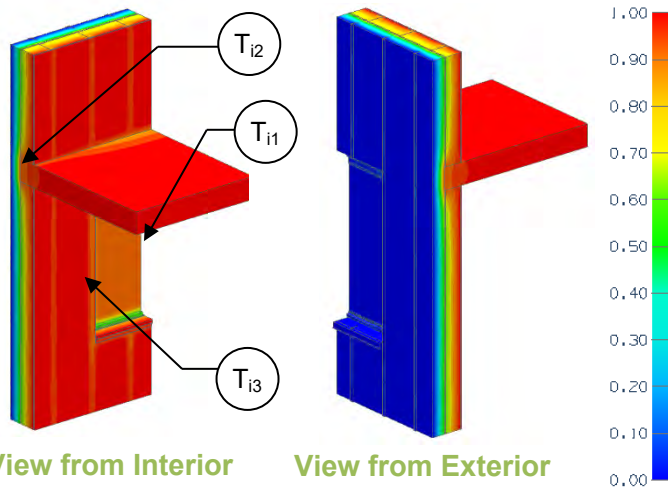

View from Interior View from Exterior

Base Assembly – Glazing

$U_{\text{centre of glass}}$ Btu/ft ² · hr · °F (W/m ² K)	U_g Btu/ft ² · hr · °F (W/m ² K)
0.142 (0.81)	0.303 (1.72)

Thermal Performance Indicators

Assembly 1D (Nominal) R-Value	R_{1D}	R-21.3 (3.75 RSI) + exterior insulation
Transmittance / Resistance without Anomaly	U_w, R_w, U_g	“clear wall” U- and R-value: w = wall without intermediate floor g = glazing
Transmittance / Resistance	$U_{\text{floor}}, R_{\text{floor}}, U_t, R_t$	U and R-values for: floor = wall + intermediate floor t = combined wall + floor + window
Surface Temperature Index ¹	T_i	0 = exterior temperature 1 = interior temperature
Linear Transmittance	ψ	Incremental increase in transmittance per linear length

¹Assumptions and limitations for surface temperatures identified in ASHRAE 1365-RP

Nominal (1D) vs. Assembly Performance Indicators

Base Assembly – Steel Stud Clear Wall

Exterior Insulation 1D R-Value (RSI)	R_{1D} ft ² ·hr·°F / Btu (m ² K / W)	R_w ft ² ·hr·°F / Btu (m ² K / W)	U_w Btu/ft ² · hr · °F (W/m ² K)
R-10 (1.76)	R-31.3 (5.51)	R-19.2 (3.38)	0.052 (0.30)
R-15 (2.64)	R-36.3 (6.39)	R-21.8 (3.83)	0.046 (0.26)
R-20 (3.52)	R-41.3 (7.28)	R-24.8 (4.37)	0.040 (0.23)
R-25 (4.40)	R-46.3 (8.15)	R-27.6 (4.86)	0.036 (0.21)

Intermediate Floor Linear Transmittance

R_{floor} ft ² ·hr·°F / Btu (m ² K / W)	U_{floor} Btu/ft ² · hr · °F (W/m ² K)	ψ_{floor} Btu/ft ² · hr · °F (W/m ² K)
R-16.1 (2.83)	0.062 (0.35)	0.071 (0.122)
R-18.5 (3.26)	0.054 (0.31)	0.056 (0.098)
R-21.3 (3.75)	0.047 (0.27)	0.046 (0.080)
R-23.9 (4.21)	0.042 (0.24)	0.040 (0.068)

Window Transition Transmittance

Exterior Insulation 1D R-Value (RSI)	R_t ft ² ·hr·°F / Btu (m ² K / W)	U_t Btu/ft ² · hr · °F (W/m ² K)	ψ_{Head} Btu/ft · hr · °F (W/m K)	ψ_{Sill} Btu/ft · hr · °F (W/m K)	ψ_{Jamb} Btu/ft · hr · °F (W/m K)	ψ_{Total} Btu/ft · hr · °F (W/m K)
R-10 (1.76)	R-7.4 (1.30)	0.135 (0.77)	0.240 (0.414)	0.073 (0.127)	0.074 (0.127)	0.110 (0.191)
R-15 (2.64)	R-7.6 (1.35)	0.131 (0.74)	0.252 (0.436)	0.079 (0.136)	0.077 (0.132)	0.118 (0.204)
R-20 (3.52)	R-7.9 (1.39)	0.127 (0.72)	0.262 (0.453)	0.083 (0.143)	0.079 (0.136)	0.123 (0.213)
R-25 (4.40)	R-8.1 (1.42)	0.124 (0.70)	0.285 (0.492)	0.086 (0.148)	0.081 (0.141)	0.129 (0.223)

Temperature Indices

	R10	R15	R20	R25	
T_{i1}	0.43	0.43	0.43	0.43	Min T on window frame, centre of window head
T_{i2}	0.74	0.80	0.82	0.84	Max T on interior surface of sheathing, along bottom track
T_{i3}	0.35	0.38	0.38	0.39	Min T on interior surface of sheathing, along window sill track

Detail 5.3.12

Exterior Insulated 6" x 1 5/8" Steel Stud (16" o.c.) Wall Assembly with Thermally Isolated Vertical Brackets and Rail System (24" o.c.) Supporting Metal Cladding – Triple Glazed Aluminum Curtain Wall & Intermediate Floor Intersection with Window Thermal Break Positioned in the Exterior Insulation

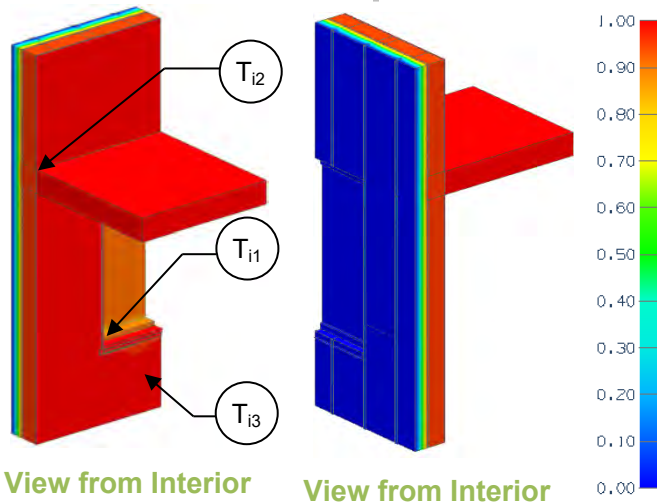

Thermal Performance Indicators

Assembly 1D (Nominal) R-Value	R_{1D}	R-3.2 (0.56 RSI) + exterior insulation
Transmittance / Resistance without Anomaly	U_w, R_w, U_g	"clear wall" U- and R-value: w = wall without intermediate floor g = glazing
Transmittance / Resistance	$U_{floor}, R_{floor}, U_t, R_t$	U and R-values for: floor = wall + intermediate floor t = combined wall + floor + window
Surface Temperature Index ¹	T_i	0 = exterior temperature 1 = interior temperature
Linear Transmittance	ψ	Incremental increase in transmittance per linear length

View from Interior View from Interior
Base Assembly – Glazing

$U_{\text{centre of glass}}$ Btu/ft ² · hr · °F (W/m ² K)	U_g Btu/ft ² · hr · °F (W/m ² K)
0.142 (0.81)	0.199 (1.13)

¹Assumptions and limitations for surface temperatures identified in ASHRAE 1365-RP

Nominal (1D) vs. Assembly Performance Indicators

Base Assembly – Steel Stud Clear Wall

Exterior Insulation 1D R-Value (RSI)	R_{1D} ft ² ·hr·°F / Btu (m ² K / W)	R_w ft ² ·hr·°F / Btu (m ² K / W)	U_w Btu/ft ² · hr · °F (W/m ² K)
R-10 (1.76)	R-13.2 (2.32)	R-11.2 (1.97)	0.090 (0.51)
R-15 (2.64)	R-18.2 (3.20)	R-13.9 (2.45)	0.072 (0.41)
R-20 (3.52)	R-23.2 (4.08)	R-16.9 (2.98)	0.059 (0.34)
R-25 (4.40)	R-28.2 (4.96)	R-19.7 (3.48)	0.051 (0.29)

Intermediate Floor Linear Transmittance

R_{floor} ft ² ·hr·°F / Btu (m ² K / W)	U_{floor} Btu/ft ² · hr · °F (W/m ² K)	ψ_{floor} Btu/ft ² · hr · °F (W/m ² K)
R-10.6 (1.88)	0.094 (0.53)	0.030 (0.052)
R-13.2 (2.32)	0.076 (0.43)	0.029 (0.051)
R-15.9 (2.81)	0.063 (0.36)	0.026 (0.045)
R-18.5 (3.27)	0.054 (0.31)	0.023 (0.040)

Window Transition Transmittance

Exterior Insulation 1D R-Value (RSI)	R_t ft ² ·hr·°F / Btu (m ² K / W)	U_t Btu/ft ² · hr · °F (W/m ² K)	ψ_{Head} Btu/ft · hr · °F (W/m K)	ψ_{Sill} Btu/ft · hr · °F (W/m K)	ψ_{Jamb} Btu/ft · hr · °F (W/m K)	ψ_{Total} Btu/ft · hr · °F (W/m K)
R-10 (1.76)	R-8.1 (1.43)	0.123 (0.70)	0.041 (0.071)	0.013 (0.023)	0.035 (0.060)	0.029 (0.050)
R-15 (2.64)	R-9.1 (1.60)	0.110 (0.62)	0.043 (0.074)	0.026 (0.044)	0.040 (0.069)	0.033 (0.058)
R-20 (3.52)	R-9.9 (1.74)	0.101 (0.58)	0.047 (0.082)	0.033 (0.058)	0.044 (0.077)	0.042 (0.072)
R-25 (4.40)	R-10.5 (1.85)	0.095 (0.54)	0.052 (0.090)	0.035 (0.061)	0.046 (0.080)	0.047 (0.081)

Temperature Indices

	R10	R15	R20	R25	
T_{i1}	0.77	0.77	0.77	0.78	Min T on window frame, at bottom corner at edge of glass
T_{i2}	0.85	0.88	0.90	0.91	Max T on interior surface of sheathing, along bottom track
T_{i3}	0.73	0.74	0.76	0.77	Min T on interior surface of sheathing, at bracket

Detail 5.3.13

Exterior and Interior Insulated 6" x 1 5/8" Steel Stud (16" o.c.) Wall Assembly with Thermally Isolated Vertical Brackets and Rail System (24" o.c.) Supporting Metal Cladding and R-19 Batt Insulation in Stud Cavity – Triple Glazed Aluminum Curtain Wall & Intermediate Floor Intersection with Window Thermal Break Positioned in the Exterior Insulation

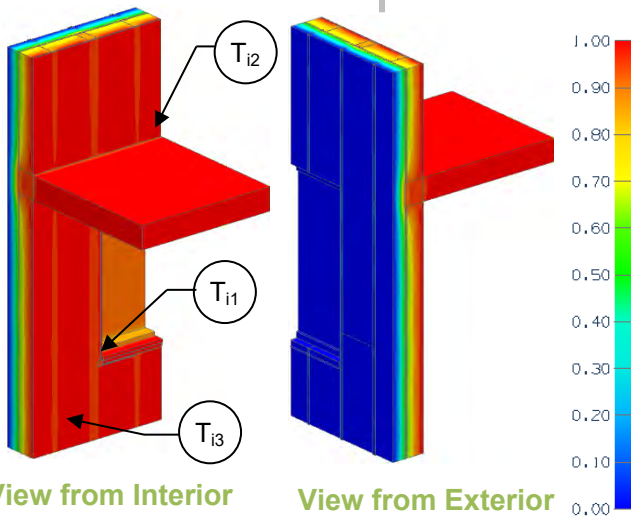

Thermal Performance Indicators

Assembly 1D (Nominal) R-Value	R_{1D}	R-21.3 (3.75 RSI) + exterior insulation
Transmittance / Resistance without Anomaly	U_w, R_w, U_g	"clear wall" U- and R-value: w = wall without intermediate floor g = glazing
Transmittance / Resistance	$U_{floor}, R_{floor}, U_t, R_t$	U and R-values for: floor = wall + intermediate floor t = combined wall + floor + window
Surface Temperature Index ¹	T_i	0 = exterior temperature 1 = interior temperature
Linear Transmittance	Ψ	Incremental increase in transmittance per linear length

View from Interior View from Exterior

Base Assembly – Glazing

$U_{\text{centre of glass}}$ Btu/ft ² · hr · °F (W/m ² K)	U_g Btu/ft ² · hr · °F (W/m ² K)
0.142 (0.81)	0.199 (1.13)

¹Assumptions and limitations for surface temperatures identified in ASHRAE 1365-RP

Nominal (1D) vs. Assembly Performance Indicators

Base Assembly – Steel Stud Clear Wall

Exterior Insulation 1D R-Value (RSI)	R_{1D} ft ² ·hr·°F / Btu (m ² K / W)	R_w ft ² ·hr·°F / Btu (m ² K / W)	U_w Btu/ft ² · hr · °F (W/m ² K)
R-10 (1.76)	R-31.3 (5.51)	R-19.2 (3.38)	0.052 (0.30)
R-15 (2.64)	R-36.3 (6.39)	R-21.8 (3.83)	0.046 (0.26)
R-20 (3.52)	R-41.3 (7.28)	R-24.8 (4.37)	0.040 (0.23)
R-25 (4.40)	R-46.3 (8.15)	R-27.6 (4.86)	0.036 (0.21)

Intermediate Floor Linear Transmittance

R_{floor} ft ² ·hr·°F / Btu (m ² K / W)	U_{floor} Btu/ft ² · hr · °F (W/m ² K)	Ψ_{floor} Btu/ft ² · hr · °F (W/m ² K)
R-16.1 (2.83)	0.062 (0.35)	0.071 (0.122)
R-18.5 (3.26)	0.054 (0.31)	0.056 (0.098)
R-21.3 (3.75)	0.047 (0.27)	0.046 (0.080)
R-23.9 (4.21)	0.042 (0.24)	0.040 (0.068)

Window Transition Transmittance

Exterior Insulation 1D R-Value (RSI)	R_t ft ² ·hr·°F / Btu (m ² K / W)	U_t Btu/ft ² · hr · °F (W/m ² K)	Ψ_{Head} Btu/ft · hr · °F (W/m K)	Ψ_{Sill} Btu/ft · hr · °F (W/m K)	Ψ_{Jamb} Btu/ft · hr · °F (W/m K)	Ψ_{Total} Btu/ft · hr · °F (W/m K)
R-10 (1.76)	R-8.1 (1.43)	0.123 (0.70)	0.036 (0.063)	0.028 (0.048)	0.046 (0.080)	0.042 (0.073)
R-15 (2.64)	R-9.1 (1.60)	0.110 (0.62)	0.040 (0.069)	0.031 (0.053)	0.047 (0.081)	0.043 (0.074)
R-20 (3.52)	R-9.9 (1.74)	0.101 (0.58)	0.044 (0.076)	0.033 (0.058)	0.048 (0.083)	0.047 (0.082)
R-25 (4.40)	R-10.5 (1.85)	0.095 (0.54)	0.048 (0.083)	0.033 (0.058)	0.047 (0.082)	0.050 (0.086)

Temperature Indices

	R10	R15	R20	R25	
T_{i1}	0.76	0.76	0.76	0.75	Min T on window frame, at bottom corner at edge of glass
T_{i2}	0.76	0.79	0.82	0.84	Max T on interior surface of sheathing, along bottom track
T_{i3}	0.41	0.44	0.48	0.51	Min T on interior surface of sheathing, between studs

Detail 5.3.14

Owens Corning Exterior Insulated 6" x 1 5/8" Steel Stud (16" o.c.) Wall Assembly with Thermally Isolated Vertical Brackets and Rail System (24" o.c.) Supporting Metal Cladding – Double Glazed Aluminum Window and Intermediate Floor Intersection

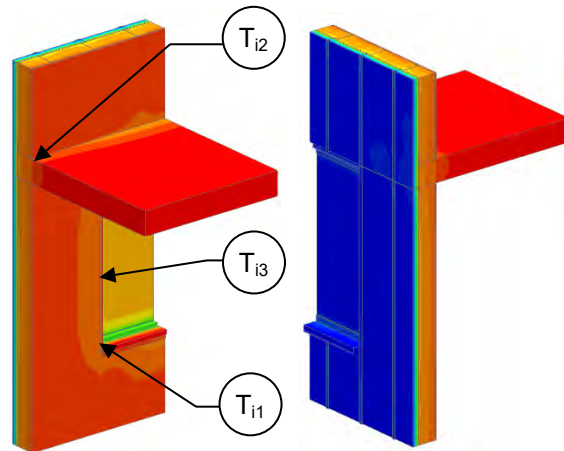

View from Interior View from Exterior

Base Assembly – Glazing

$U_{\text{centre of glass}}$ Btu/ft ² · hr · °F (W/m ² K)	U_g Btu/ft ² · hr · °F (W/m ² K)
0.321 (1.82)	0.396 (2.25)

Thermal Performance Indicators

Assembly 1D (Nominal) R-Value	R_{1D}	R-3.3 (0.58 RSI) + exterior insulation
Transmittance / Resistance without Anomaly	$U_w, R_w, U_g,$	“clear wall” U- and R-value: w = wall without intermediate floor g = glazing
Transmittance / Resistance	$U_{\text{floor}}, R_{\text{floor}}, U_t, R_t$	U and R-values for: floor = wall + intermediate floor t = combined wall + floor + window
Surface Temperature Index ¹	T_i	0 = exterior temperature 1 = interior temperature
Linear Transmittance	ψ	Incremental increase in transmittance per linear length

¹Assumptions and limitations for surface temperatures identified in ASHRAE 1365-RP

Nominal (1D) vs. Assembly Performance Indicators

Base Assembly – Steel Stud Clear Wall

Exterior Insulation 1D R-Value (RSI)	R_{1D} ft ² ·hr·°F / Btu (m ² K / W)	R_w ft ² ·hr·°F / Btu (m ² K / W)	U_w Btu/ft ² · hr · °F (W/m ² K)
R-8.4 (1.48)	R-11.7 (2.06)	R-10.0 (1.77)	0.100 (0.57)
R-21.0 (3.70)	R-24.3 (4.28)	R-17.6 (3.10)	0.057 (0.32)

Intermediate Floor Linear Transmittance

R_{floor} ft ² ·hr·°F / Btu (m ² K / W)	U_{floor} Btu/ft ² · hr · °F (W/m ² K)	ψ_{floor} Btu/ft ² · hr · °F (W/m ² K)
R-9.7 (1.72)	0.103 (0.58)	0.020 (0.034)
R-17.0 (3.00)	0.059 (0.33)	0.013 (0.023)

Window Transition Transmittance

Exterior Insulation 1D R-Value (RSI)	R_t ft ² ·hr·°F / Btu (m ² K / W)	U_t Btu/ft ² · hr · °F (W/m ² K)	ψ_{Head} Btu/ft · hr · °F (W/m K)	ψ_{Sill} Btu/ft · hr · °F (W/m K)	ψ_{Jamb} Btu/ft · hr · °F (W/m K)	ψ_{Total} Btu/ft · hr · °F (W/m K)
R-8.4 (1.48)	R-4.8 (0.84)	0.210 (1.19)	0.276 (0.478)	0.215 (0.373)	0.124 (0.214)	0.182 (0.315)
R-21.0 (3.70)	R-5.4 (0.96)	0.184 (1.04)	0.298 (0.516)	0.248 (0.429)	0.143 (0.248)	0.216 (0.374)

Temperature Indices

	R8.4	R21	
T_{i1}	0.54	0.57	Min T on window frame, at bottom corner at edge of glass
T_{i2}	0.83	0.89	Max T on interior surface of sheathing, along bottom track
T_{i3}	0.37	0.38	Min T on interior surface of sheathing, at bracket along jamb

Detail 5.3.15

Exterior and Interior Insulated 6" x 1 5/8" Steel Stud (16" o.c.) Wall Assembly with Thermally Isolated Vertical Brackets and Rail System (24" o.c.) Supporting Metal Cladding and Owens Corning R-20 Batt in Stud Cavity – Double Glazed Aluminum Window and Intermediate Floor Intersection

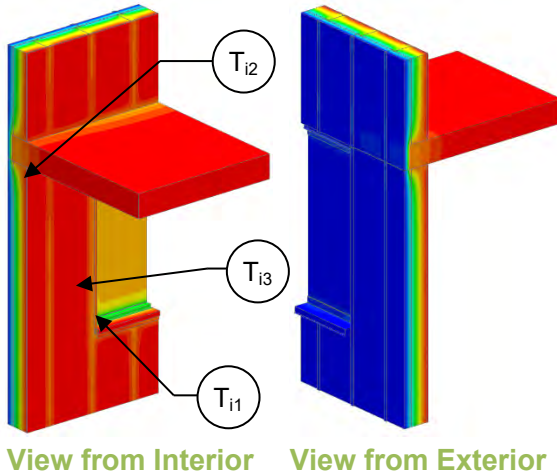

Thermal Performance Indicators

Assembly 1D (Nominal) R-Value	R_{1D}	R-22.4 (3.94 RSI) + exterior insulation
Transmittance / Resistance without Anomaly	U_w, R_w, U_g	"clear wall" U- and R-value: w = wall without intermediate floor g = glazing
Transmittance / Resistance	$U_{floor}, R_{floor}, U_t, R_t$	U and R-values for: floor = wall + intermediate floor t = combined wall + floor + window
Surface Temperature Index ¹	T_i	0 = exterior temperature 1 = interior temperature
Linear Transmittance	Ψ	Incremental increase in transmittance per linear length

¹Assumptions and limitations for surface temperatures identified in ASHRAE 1365-RP

Base Assembly – Glazing

$U_{\text{centre of glass}}$ Btu/ft ² · hr · °F (W/m ² K)	U_g Btu/ft ² · hr · °F (W/m ² K)
0.321 (1.82)	0.396 (2.25)

Nominal (1D) vs. Assembly Performance Indicators

Base Assembly – Steel Stud Clear Wall

Exterior Insulation 1D R-Value (RSI)	R_{1D} ft ² ·hr·°F / Btu (m ² K / W)	R_w ft ² ·hr·°F / Btu (m ² K / W)	U_w Btu/ft ² · hr · °F (W/m ² K)
R-8.4 (1.48)	R-30.8 (5.42)	R-18.3 (3.23)	0.055 (0.31)
R-21.0 (3.70)	R-43.4 (7.64)	R-25.8 (4.54)	0.039 (0.22)

Intermediate Floor Linear Transmittance

R_{floor} ft ² ·hr·°F / Btu (m ² K / W)	U_{floor} Btu/ft ² · hr · °F (W/m ² K)	Ψ_{floor} Btu/ft ² · hr · °F (W/m ² K)
R-15.3 (2.69)	0.065 (0.37)	0.076 (0.132)
R-22.5 (3.96)	0.045 (0.25)	0.040 (0.069)

Window Transition Transmittance

Exterior Insulation 1D R-Value (RSI)	R_t ft ² ·hr·°F / Btu (m ² K / W)	U_t Btu/ft ² · hr · °F (W/m ² K)	Ψ_{Head} Btu/ft · hr · °F (W/m K)	Ψ_{Sill} Btu/ft · hr · °F (W/m K)	Ψ_{Jamb} Btu/ft · hr · °F (W/m K)	Ψ_{Total} Btu/ft · hr · °F (W/m K)
R-8.4 (1.48)	R-5.8 (1.02)	0.173 (0.99)	0.308 (0.533)	0.146 (0.253)	0.094 (0.163)	0.159 (0.274)
R-21.0 (3.70)	R-6.2 (1.10)	0.161 (0.91)	0.303 (0.525)	0.158 (0.273)	0.102 (0.176)	0.164 (0.283)

Temperature Indices

	R8.4	R21	
T_{i1}	0.50	0.50	Min T on window frame, at bottom corner at edge of glass
T_{i2}	0.80	0.86	Max T on interior surface of sheathing, along bottom track
T_{i3}	0.28	0.28	Min T on interior surface of sheathing, at bracket along jamb

Detail 5.3.16

Exterior and Interior Insulated 6" x 1 5/8" Steel Stud (16" o.c.) Wall Assembly with Thermally Isolated Vertical Brackets and Rail System (24" o.c.) Supporting Metal Cladding and Owens Corning R-22.5 Batt in Stud Cavity – Double Glazed Aluminum Window and Intermediate Floor Intersection

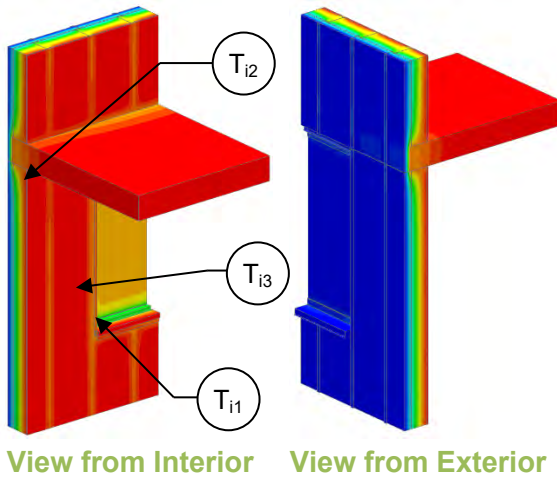

Thermal Performance Indicators

Assembly 1D (Nominal) R-Value	R_{1D}	R-24.9 (4.38 RSI) + exterior insulation
Transmittance / Resistance without Anomaly	U_w, R_w, U_g	"clear wall" U- and R-value: w = wall without intermediate floor g = glazing
Transmittance / Resistance	$U_{floor}, R_{floor}, U_t, R_t$	U and R-values for: floor = wall + intermediate floor t = combined wall + floor + window
Surface Temperature Index ¹	T_i	0 = exterior temperature 1 = interior temperature
Linear Transmittance	Ψ	Incremental increase in transmittance per linear length

¹Assumptions and limitations for surface temperatures identified in ASHRAE 1365-RP

Base Assembly – Glazing

$U_{\text{centre of glass}}$ Btu/ft ² · hr · °F (W/m ² K)	U_g Btu/ft ² · hr · °F (W/m ² K)
0.321 (1.82)	0.396 (2.25)

Nominal (1D) vs. Assembly Performance Indicators

Base Assembly – Steel Stud Clear Wall

Exterior Insulation 1D R-Value (RSI)	R_{1D} ft ² ·hr·°F / Btu (m ² K / W)	R_w ft ² ·hr·°F / Btu (m ² K / W)	U_w Btu/ft ² · hr · °F (W/m ² K)
R-8.4 (1.48)	R-33.3 (5.86)	R-19.0 (3.34)	0.053 (0.30)
R-21.0 (3.70)	R-45.9 (8.08)	R-26.4 (4.64)	0.038 (0.22)

Intermediate Floor Linear Transmittance

R_{floor} ft ² ·hr·°F / Btu (m ² K / W)	U_{floor} Btu/ft ² · hr · °F (W/m ² K)	Ψ_{floor} Btu/ft ² · hr · °F (W/m ² K)
R-15.6 (2.75)	0.064 (0.36)	0.079 (0.136)
R-22.8 (4.02)	0.044 (0.25)	0.041 (0.071)

Window Transition Transmittance

Exterior Insulation 1D R-Value (RSI)	R_t ft ² ·hr·°F / Btu (m ² K / W)	U_t Btu/ft ² · hr · °F (W/m ² K)	Ψ_{Head} Btu/ft · hr · °F (W/m K)	Ψ_{Sill} Btu/ft · hr · °F (W/m K)	Ψ_{Jamb} Btu/ft · hr · °F (W/m K)	Ψ_{Total} Btu/ft · hr · °F (W/m K)
R-8.4 (1.48)	R-5.8 (1.02)	0.172 (0.98)	0.310 (0.536)	0.146 (0.252)	0.094 (0.163)	0.159 (0.275)
R-21.0 (3.70)	R-6.3 (1.10)	0.160 (0.91)	0.304 (0.526)	0.157 (0.271)	0.101 (0.175)	0.163 (0.282)

Temperature Indices

	R8.4	R21	
T_{i1}	0.50	0.50	Min T on window frame, at bottom corner at edge of glass
T_{i2}	0.79	0.86	Max T on interior surface of sheathing, along bottom track
T_{i3}	0.27	0.28	Min T on interior surface of sheathing, at bracket along jamb

Detail 5.3.17

Owens Corning Exterior Insulated 6" x 1 5/8" Steel Stud (16" o.c.) Wall Assembly with Thermally Isolated Vertical Brackets and Rail System (24" o.c.) Supporting Metal Cladding – Triple Glazed Aluminum Window and Intermediate Floor Intersection

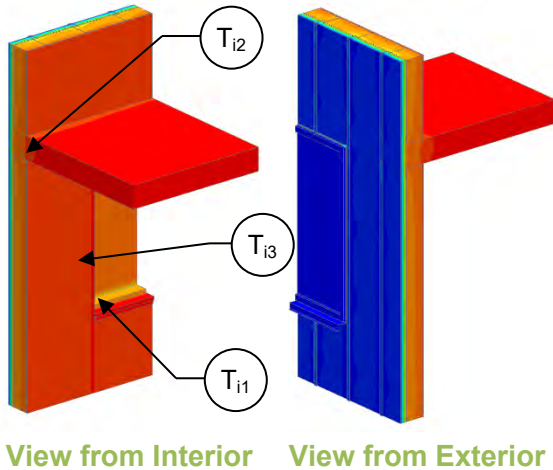

Thermal Performance Indicators

1.00	<table border="1"> <tr> <td>Assembly 1D (Nominal) R-Value</td> <td>R_{1D}</td> <td>R-3.3 (0.58 RSI) + exterior insulation</td> </tr> <tr> <td>Transmittance / Resistance without Anomaly</td> <td>U_w, R_w, U_g</td> <td>"clear wall" U- and R-value: w = wall without intermediate floor g = glazing</td> </tr> <tr> <td>Transmittance / Resistance</td> <td>$U_{floor}, R_{floor}, U_t, R_t$</td> <td>U and R-values for: floor = wall + intermediate floor t = combined wall + floor + window</td> </tr> <tr> <td>Linear Transmittance</td> <td>ψ</td> <td>Incremental increase in transmittance per linear length</td> </tr> </table>	Assembly 1D (Nominal) R-Value	R_{1D}	R-3.3 (0.58 RSI) + exterior insulation	Transmittance / Resistance without Anomaly	U_w, R_w, U_g	"clear wall" U- and R-value: w = wall without intermediate floor g = glazing	Transmittance / Resistance	$U_{floor}, R_{floor}, U_t, R_t$	U and R-values for: floor = wall + intermediate floor t = combined wall + floor + window	Linear Transmittance	ψ	Incremental increase in transmittance per linear length	0.90
Assembly 1D (Nominal) R-Value		R_{1D}	R-3.3 (0.58 RSI) + exterior insulation											
Transmittance / Resistance without Anomaly		U_w, R_w, U_g	"clear wall" U- and R-value: w = wall without intermediate floor g = glazing											
Transmittance / Resistance		$U_{floor}, R_{floor}, U_t, R_t$	U and R-values for: floor = wall + intermediate floor t = combined wall + floor + window											
Linear Transmittance		ψ	Incremental increase in transmittance per linear length											
0.80	0.70													
0.60	0.50													
0.40	0.30													
0.20	0.10													
0.00														

*Assumptions and limitations for surface temperatures identified in ASHRAE 1365-RP

Base Assembly – Glazing

$U_{\text{centre of glass}}$ Btu/ft ² · hr · °F (W/m ² K)	U_g Btu/ft ² · hr · °F (W/m ² K)
0.220 (1.25)	0.208 (1.18)

Nominal (1D) vs. Assembly Performance Indicators

Base Assembly – Steel Stud Clear Wall

Exterior Insulation 1D R-Value (RSI)	R_{1D} ft ² ·hr·°F / Btu (m ² K / W)	R_w ft ² ·hr·°F / Btu (m ² K / W)	U_w Btu/ft ² · hr · °F (W/m ² K)
R-8.4 (1.48)	R-11.7 (2.06)	R-10.0 (1.77)	0.100 (0.57)
R-21.0 (3.70)	R-24.3 (4.28)	R-17.6 (3.10)	0.057 (0.32)

Intermediate Floor Linear Transmittance

R_{floor} ft ² ·hr·°F / Btu (m ² K / W)	U_{floor} Btu/ft ² · hr · °F (W/m ² K)	ψ_{floor} Btu/ft ² · hr · °F (W/m ² K)
R-9.7 (1.72)	0.103 (0.58)	0.020 (0.034)
R-17.0 (3.00)	0.059 (0.33)	0.013 (0.023)

Window Transition Transmittance

Exterior Insulation 1D R-Value (RSI)	R_t ft ² ·hr·°F / Btu (m ² K / W)	U_t Btu/ft ² · hr · °F (W/m ² K)	ψ_{Head} Btu/ft · hr · °F (W/m K)	ψ_{Sill} Btu/ft · hr · °F (W/m K)	ψ_{Jamb} Btu/ft · hr · °F (W/m K)	ψ_{Total} Btu/ft · hr · °F (W/m K)
R-8.4 (1.48)	R-7.5 (1.32)	0.133 (0.76)	0.050 (0.086)	0.033 (0.057)	0.043 (0.075)	0.033 (0.056)
R-21.0 (3.70)	R-9.4 (1.65)	0.107 (0.61)	0.045 (0.078)	0.052 (0.090)	0.047 (0.082)	0.062 (0.107)

Temperature Indices

	R8.4	R21	
T_{i1}	0.71	0.71	Min T on window frame, at bottom corner at edge of glass
T_{i2}	0.86	0.91	Max T on interior surface of sheathing, along bottom track
T_{i3}	0.69	0.66	Min T on interior surface of sheathing, at bracket along jamb

Detail 5.3.18

Exterior and Interior Insulated 6" x 1 5/8" Steel Stud (16" o.c.) Wall Assembly with Thermally Isolated Vertical Brackets and Rail System (24" o.c.) Supporting Metal Cladding and Owens Corning R-20 Batt in Stud Cavity – Triple Glazed Aluminum Window and Intermediate Floor Intersection

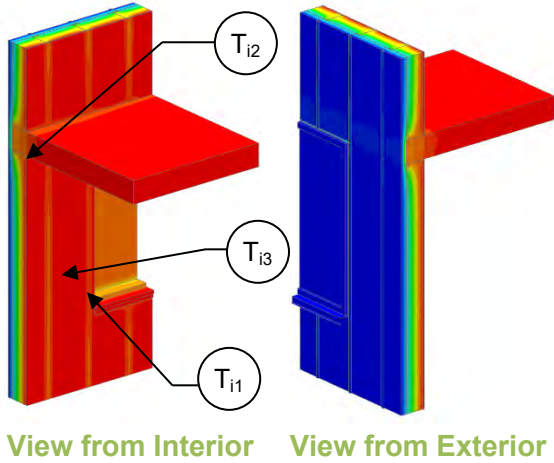

Thermal Performance Indicators

Assembly 1D (Nominal) R-Value	R_{1D}	R-22.4 (3.94 RSI) + exterior insulation
Transmittance / Resistance without Anomaly	U_w, R_w, U_g	"clear wall" U- and R-value: w = wall without intermediate floor g = glazing
Transmittance / Resistance	$U_{floor}, R_{floor}, U_t, R_t$	U and R-values for: floor = wall + intermediate floor t = combined wall + floor + window
Linear Transmittance	ψ	Incremental increase in transmittance per linear length

Base Assembly – Glazing

$U_{\text{centre of glass}}$ Btu/ft ² · hr · °F (W/m ² K)	U_g Btu/ft ² · hr · °F (W/m ² K)
0.220 (1.25)	0.208 (1.18)

¹Assumptions and limitations for surface temperatures identified in ASHRAE 1365-RP

Nominal (1D) vs. Assembly Performance Indicators

Base Assembly – Steel Stud Clear Wall

Exterior Insulation 1D R-Value (RSI)	R_{1D} ft ² ·hr·°F / Btu (m ² K / W)	R_w ft ² ·hr·°F / Btu (m ² K / W)	U_w Btu/ft ² · hr · °F (W/m ² K)
R-8.4 (1.48)	R-30.8 (5.42)	R-18.3 (3.23)	0.055 (0.31)
R-21.0 (3.70)	R-43.4 (7.64)	R-25.8 (4.54)	0.039 (0.22)

Intermediate Floor Linear Transmittance

R_{floor} ft ² ·hr·°F / Btu (m ² K / W)	U_{floor} Btu/ft ² · hr · °F (W/m ² K)	ψ_{floor} Btu/ft ² · hr · °F (W/m ² K)
R-15.3 (2.69)	0.065 (0.37)	0.076 (0.132)
R-22.5 (3.96)	0.045 (0.25)	0.040 (0.069)

Window Transition Transmittance

Exterior Insulation 1D R-Value (RSI)	R_t ft ² ·hr·°F / Btu (m ² K / W)	U_t Btu/ft ² · hr · °F (W/m ² K)	ψ_{Head} Btu/ft · hr · °F (W/m K)	ψ_{Sill} Btu/ft · hr · °F (W/m K)	ψ_{Jamb} Btu/ft · hr · °F (W/m K)	ψ_{Total} Btu/ft · hr · °F (W/m K)
R-8.4 (1.48)	R-9.7 (1.70)	0.103 (0.59)	0.093 (0.162)	0.033 (0.057)	0.045 (0.078)	0.044 (0.077)
R-21.0 (3.70)	R-10.9 (1.92)	0.092 (0.52)	0.063 (0.109)	0.043 (0.075)	0.043 (0.075)	0.052 (0.091)

Temperature Indices

	R8.4	R21	
T_{i1}	0.70	0.70	Min T on window frame, at bottom corner at edge of glass
T_{i2}	0.84	0.89	Max T on interior surface of sheathing, along bottom track
T_{i3}	0.36	0.47	Min T on interior surface of sheathing, between studs

Detail 5.3.19

Exterior and Interior Insulated 6" x 1 5/8" Steel Stud (16" o.c.) Wall Assembly with Thermally Isolated Vertical Brackets and Rail System (24" o.c.) Supporting Metal Cladding and Owens Corning R-22.5 Batt in Stud Cavity – Triple Glazed Aluminum Window and Intermediate Floor Intersection

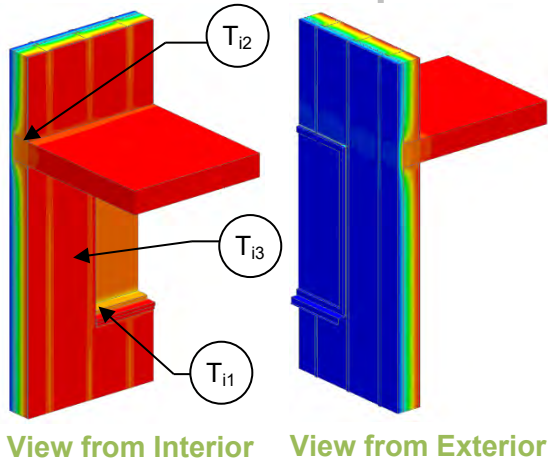

Thermal Performance Indicators

Assembly 1D (Nominal) R-Value	R_{1D}	R-24.9 (4.38 RSI) + exterior insulation
Transmittance / Resistance without Anomaly	U_w, R_w, U_g	"clear wall" U- and R-value: w = wall without intermediate floor g = glazing
Transmittance / Resistance	$U_{floor}, R_{floor}, U_t, R_t$	U and R-values for: floor = wall + intermediate floor t = combined wall + floor + window
Linear Transmittance	ψ	Incremental increase in transmittance per linear length

¹Assumptions and limitations for surface temperatures identified in ASHRAE 1365-RP

Base Assembly – Glazing

$U_{\text{centre of glass}}$ Btu/ft ² · hr · °F (W/m ² K)	U_g Btu/ft ² · hr · °F (W/m ² K)
0.220 (1.25)	0.208 (1.18)

Nominal (1D) vs. Assembly Performance Indicators

Base Assembly – Steel Stud Clear Wall

Exterior Insulation 1D R-Value (RSI)	R_{1D} ft ² ·hr·°F / Btu (m ² K / W)	R_w ft ² ·hr·°F / Btu (m ² K / W)	U_w Btu/ft ² · hr · °F (W/m ² K)
R-8.4 (1.48)	R-33.3 (5.86)	R-19.0 (3.34)	0.053 (0.30)
R-21.0 (3.70)	R-45.9 (8.08)	R-26.4 (4.64)	0.038 (0.22)

Intermediate Floor Linear Transmittance

R_{floor} ft ² ·hr·°F / Btu (m ² K / W)	U_{floor} Btu/ft ² · hr · °F (W/m ² K)	ψ_{floor} Btu/ft ² · hr · °F (W/m ² K)
R-15.6 (2.75)	0.064 (0.36)	0.079 (0.136)
R-22.8 (4.02)	0.044 (0.25)	0.041 (0.071)

Window Transition Transmittance

Exterior Insulation 1D R-Value (RSI)	R_t ft ² ·hr·°F / Btu (m ² K / W)	U_t Btu/ft ² · hr · °F (W/m ² K)	ψ_{Head} Btu/ft · hr · °F (W/m K)	ψ_{Sill} Btu/ft · hr · °F (W/m K)	ψ_{Jamb} Btu/ft · hr · °F (W/m K)	ψ_{Total} Btu/ft · hr · °F (W/m K)
R-8.4 (1.48)	R-9.7 (1.70)	0.103 (0.59)	0.095 (0.165)	0.033 (0.057)	0.045 (0.079)	0.045 (0.078)
R-21.0 (3.70)	R-10.9 (1.92)	0.092 (0.52)	0.064 (0.111)	0.045 (0.078)	0.043 (0.075)	0.053 (0.091)

Temperature Indices

	R8.4	R21	
T_{i1}	0.70	0.70	Min T on window frame, at bottom corner at edge of glass
T_{i2}	0.84	0.89	Max T on interior surface of sheathing, along bottom track
T_{i3}	0.34	0.46	Min T on interior surface of sheathing, between studs

Detail 5.3.20

Exterior Insulated 6" x 1 5/8" Steel Stud (16" o.c.) Wall Assembly with FRP and Thermally Broken Vertical Brackets and Rail System Supporting Metal Cladding – Triple Glazed Vinyl Window and Intermediate Floor Intersection

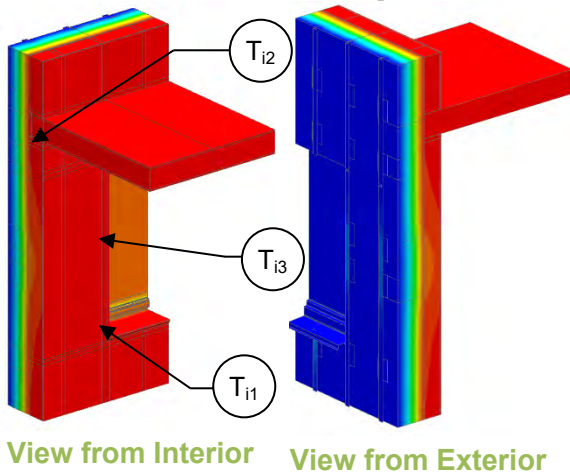

Thermal Performance Indicators

Assembly 1D (Nominal) R-Value	R_{1D}	R-3.2 (0.56 RSI) + exterior insulation
Transmittance / Resistance without Anomaly	U_w, R_w, U_g	"clear wall" U- and R-value: w = wall without intermediate floor g = glazing
Transmittance / Resistance	$U_{floor}, R_{floor}, U_t, R_t$	U and R-values for: floor = wall + intermediate floor t = combined wall + floor + window
Linear Transmittance	ψ	Incremental increase in transmittance per linear length

*Assumptions and limitations for surface temperatures identified in ASHRAE 1365-RP

Base Assembly – Glazing

$U_{\text{centre of glass}}$ Btu/ft ² · hr · °F (W/m ² K)	U_g Btu/ft ² · hr · °F (W/m ² K)
0.126 (0.72)	0.178 (1.01)

Scenario

Scenario	
A	With support bracket
B	Without support bracket

Nominal (1D) vs. Assembly Performance Indicators

Base Assembly – Steel Stud Clear Wall

Exterior Insulation 1D R-Value (RSI)	R_{1D} ft ² ·hr·°F / Btu (m ² K / W)	R_w ft ² ·hr·°F / Btu (m ² K / W)	U_w Btu/ft ² · hr · °F (W/m ² K)
R-42 (7.40)	R-45.2 (7.96)	R-40.0 (7.04)	0.025 (0.14)

Intermediate Floor Linear Transmittance

R_{floor} ft ² ·hr·°F / Btu (m ² K / W)	U_{floor} Btu/ft ² · hr · °F (W/m ² K)	ψ_{floor} Btu/ft ² · hr · °F (W/m ² K)
R-39.5 (6.96)	0.025 (0.14)	0.002 (0.003)

Window Transition Transmittance

Scenario	R_t ft ² ·hr·°F / Btu (m ² K / W)	U_t Btu/ft ² · hr · °F (W/m ² K)	ψ_{Head} Btu/ft · hr · °F (W/m K)	ψ_{Sill} Btu/ft · hr · °F (W/m K)	ψ_{Jamb} Btu/ft · hr · °F (W/m K)	ψ_{Total} Btu/ft · hr · °F (W/m K)
A	R-11.7 (2.06)	0.085 (0.49)	0.026 (0.046)	0.048 (0.083)	0.051 (0.088)	0.045 (0.078)
B	R-11.8 (2.07)	0.085 (0.48)	0.026 (0.046)	0.036 (0.062)	0.051 (0.088)	0.043 (0.074)

Temperature Indices

	A	B	
T_{i1}	0.62	0.62	Min T on window frame, at bottom corner at edge of glass
T_{i2}	0.97	0.97	Max T on interior surface of sheathing, along top track
T_{i3}	0.77	0.77	Min T on interior surface of sheathing, at bracket along jamb

Detail 5.3.21

Exterior Insulated 6" x 1 5/8" Steel Stud (16" o.c.) Wall Assembly with FRP and Thermally Broken Vertical Brackets and Rail System Supporting Metal Cladding with Aerogel Insulation Blanket – Triple Glazed Vinyl Window and Intermediate Floor Intersection

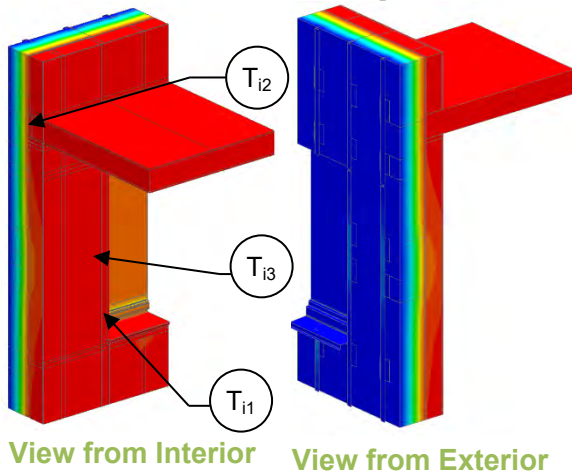

Thermal Performance Indicators

Assembly 1D (Nominal) R-Value	R _{1D}	R-3.2 (0.56 RSI) + exterior insulation
Transmittance / Resistance without Anomaly	U _w , R _w , U _g	"clear wall" U- and R-value: w = wall without intermediate floor g = glazing
Transmittance / Resistance	U _{floor} , R _{floor} , U _t , R _t	U and R-values for: floor = wall + intermediate floor t = combined wall + floor + window
Linear Transmittance	ψ	Incremental increase in transmittance per linear length

¹Assumptions and limitations for surface temperatures identified in ASHRAE 1365-RP

Base Assembly – Glazing

U _{centre of glass} Btu/ft ² · hr · °F (W/m ² K)	U _g Btu/ft ² · hr · °F (W/m ² K)
0.126 (0.72)	0.178 (1.01)

Scenario

Scenario	
A	With support bracket
B	Without support bracket

Nominal (1D) vs. Assembly Performance Indicators

Base Assembly – Steel Stud Clear Wall

Exterior Insulation 1D R-Value (RSI)	R _{1D} ft ² ·hr·°F / Btu (m ² K / W)	R _w ft ² ·hr·°F / Btu (m ² K / W)	U _w Btu/ft ² · hr · °F (W/m ² K)
R-42 (7.40)	R-45.2 (7.96)	R-40.0 (7.04)	0.025 (0.14)

Intermediate Floor Linear Transmittance

R _{floor} ft ² ·hr·°F / Btu (m ² K / W)	U _{floor} Btu/ft ² · hr · °F (W/m ² K)	ψ _{floor} Btu/ft ² · hr · °F (W/m ² K)
R-39.5 (6.96)	0.025 (0.14)	0.002 (0.003)

Window Transition Transmittance

Scenario	R _t ft ² ·hr·°F / Btu (m ² K / W)	U _t Btu/ft ² · hr · °F (W/m ² K)	ψ ^{Head} Btu/ft · hr · °F (W/m K)	ψ ^{Sill} Btu/ft · hr · °F (W/m K)	ψ ^{Jamb} Btu/ft · hr · °F (W/m K)	ψ ^{Total} Btu/ft · hr · °F (W/m K)
A	R-12.0 (2.11)	0.084 (0.48)	0.020 (0.035)	0.044 (0.075)	0.029 (0.051)	0.035 (0.061)
B	R-12.0 (2.12)	0.083 (0.47)	0.020 (0.035)	0.030 (0.052)	0.029 (0.051)	0.032 (0.056)

Temperature Indices

	A	B	
T _{i1}	0.62	0.61	Min T on window frame, at bottom corner at edge of glass
T _{i2}	0.96	0.96	Max T on interior surface of sheathing, along top track
T _{i3}	0.73	0.73	Min T on interior surface of sheathing, at bracket along jamb

Detail 5.3.22

Exterior and Interior Insulated 6" x 1 5/8" Steel Stud (16" o.c.) Wall Assembly with FRP and Thermally Broken Vertical Brackets and Rail System Supporting Metal Cladding and R-19 Batt in Stud Cavity – Triple Glazed Vinyl Window and Intermediate Floor Intersection

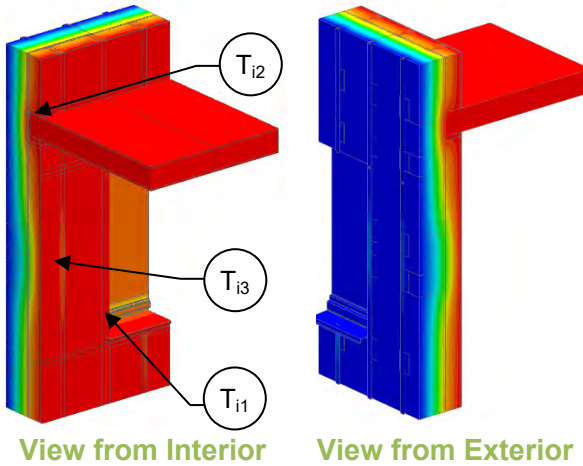

Thermal Performance Indicators

Assembly 1D (Nominal) R-Value	R _{1D}	R-21.3 (3.75 RSI) + exterior insulation
Transmittance / Resistance without Anomaly	U _w , R _w , U _g	"clear wall" U- and R-value: w = wall without intermediate floor g = glazing
Transmittance / Resistance	U _{floor} , R _{floor} , U _t , R _t	U and R-values for: floor = wall + intermediate floor t = combined wall + floor + window
Linear Transmittance	ψ	Incremental increase in transmittance per linear length

¹Assumptions and limitations for surface temperatures identified in ASHRAE 1365-RP

Base Assembly – Glazing

U _{centre of glass} Btu/ft ² · hr · °F (W/m ² K)	U _g Btu/ft ² · hr · °F (W/m ² K)
0.126 (0.72)	0.178 (1.01)

Scenario

Scenario	
A	With support bracket
B	Without support bracket

Nominal (1D) vs. Assembly Performance Indicators

Base Assembly – Steel Stud Clear Wall

Exterior Insulation 1D R-Value (RSI)	R _{1D} ft ² ·hr·°F / Btu (m ² K / W)	R _w ft ² ·hr·°F / Btu (m ² K / W)	U _w Btu/ft ² · hr · °F (W/m ² K)
R-42 (7.40)	R-63.3 (11.15)	R-48.3 (8.51)	0.021 (0.12)

Intermediate Floor Linear Transmittance

R _{floor} ft ² ·hr·°F / Btu (m ² K / W)	U _{floor} Btu/ft ² · hr · °F (W/m ² K)	ψ _{floor} Btu/ft ² · hr · °F (W/m ² K)
R-45.0 (7.92)	0.022 (0.13)	0.008 (0.015)

Window Transition Transmittance

Scenario	R _t ft ² ·hr·°F / Btu (m ² K / W)	U _t Btu/ft ² · hr · °F (W/m ² K)	ψ _{Head} Btu/ft ² · hr · °F (W/m K)	ψ _{Sill} Btu/ft ² · hr · °F (W/m K)	ψ _{Jamb} Btu/ft ² · hr · °F (W/m K)	ψ _{Total} Btu/ft ² · hr · °F (W/m K)
A	R-12.5 (2.21)	0.080 (0.45)	0.027 (0.047)	0.057 (0.099)	0.063 (0.109)	0.053 (0.091)
B	R-12.6 (2.22)	0.079 (0.45)	0.027 (0.047)	0.047 (0.081)	0.063 (0.109)	0.050 (0.087)

Temperature Indices

	A	B	
T _{i1}	0.62	0.61	Min T on window frame, at bottom corner at edge of glass
T _{i2}	0.96	0.96	Max T on interior surface of sheathing, along bottom track
T _{i3}	0.42	0.42	Min T on interior surface of sheathing, at aluminum bracket

Detail 5.3.23

Exterior and Interior Insulated 6" x 1 5/8" Steel Stud (16" o.c.) Wall Assembly with FRP and Thermally Broken Vertical Brackets and Rail System Supporting Metal Cladding with Aerogel Insulation Blanket and R-19 Batt in Stud Cavity– Triple Glazed Vinyl Window and Intermediate Floor Intersection

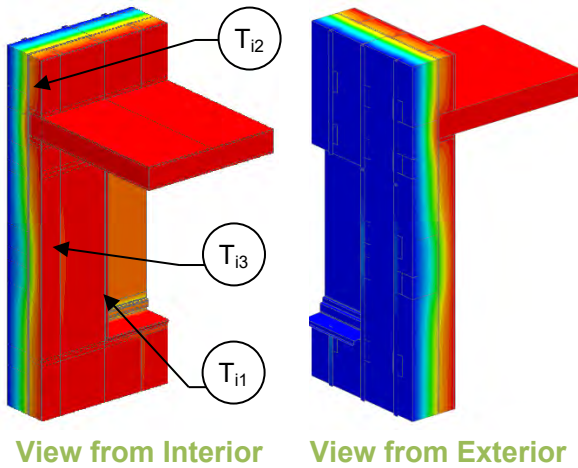

Thermal Performance Indicators

Assembly 1D (Nominal) R-Value	R _{1D}	R-21.3 (3.75 RSI) + exterior insulation
Transmittance / Resistance without Anomaly	U _w , R _w , U _g	"clear wall" U- and R-value: w = wall without intermediate floor g = glazing
Transmittance / Resistance	U _{floor} , R _{floor} , U _t , R _t	U and R-values for: floor = wall + intermediate floor t = combined wall + floor + window
Linear Transmittance	ψ	Incremental increase in transmittance per linear length

¹Assumptions and limitations for surface temperatures identified in ASHRAE 1365-RP

Base Assembly – Glazing

U _{centre of glass} Btu/ft ² · hr · °F (W/m ² K)	U _g Btu/ft ² · hr · °F (W/m ² K)
0.126 (0.72)	0.178 (1.01)

Scenario

Scenario	
A	With support bracket
B	Without support bracket

Nominal (1D) vs. Assembly Performance Indicators

Base Assembly – Steel Stud Clear Wall

Exterior Insulation 1D R-Value (RSI)	R _{1D} ft ² ·hr·°F / Btu (m ² K / W)	R _w ft ² ·hr·°F / Btu (m ² K / W)	U _w Btu/ft ² · hr · °F (W/m ² K)
R-42 (7.40)	R-63.3 (11.15)	R-48.3 (8.51)	0.021 (0.12)

Intermediate Floor Linear Transmittance

R _{floor} ft ² ·hr·°F / Btu (m ² K / W)	U _{floor} Btu/ft ² · hr · °F (W/m ² K)	ψ _{floor} Btu/ft ² · hr · °F (W/m ² K)
R-45.0 (7.92)	0.022 (0.13)	0.008 (0.015)

Window Transition Transmittance

Scenario	R _t ft ² ·hr·°F / Btu (m ² K / W)	U _t Btu/ft ² · hr · °F (W/m ² K)	ψ _{Head} Btu/ft · hr · °F (W/m K)	ψ _{Sill} Btu/ft · hr · °F (W/m K)	ψ _{Jamb} Btu/ft · hr · °F (W/m K)	ψ _{Total} Btu/ft · hr · °F (W/m K)
A	R-12.9 (2.28)	0.077 (0.44)	0.021 (0.036)	0.049 (0.084)	0.039 (0.068)	0.040 (0.069)
B	R-13.0 (2.29)	0.077 (0.44)	0.021 (0.036)	0.040 (0.069)	0.039 (0.068)	0.037 (0.065)

Temperature Indices

	A	B	
T ₁₁	0.61	0.61	Min T on window frame, at bottom corner at edge of glass
T ₁₂	0.95	0.95	Max T on interior surface of sheathing, along bottom track
T ₁₃	0.41	0.41	Min T on interior surface of sheathing, at aluminum bracket

Detail 5.4.1

Exterior Insulated 3 5/8" x 1 5/8" Steel Stud (16" o.c.) Drained EIFS Wall Assembly – Conventional Curtain Wall Transition

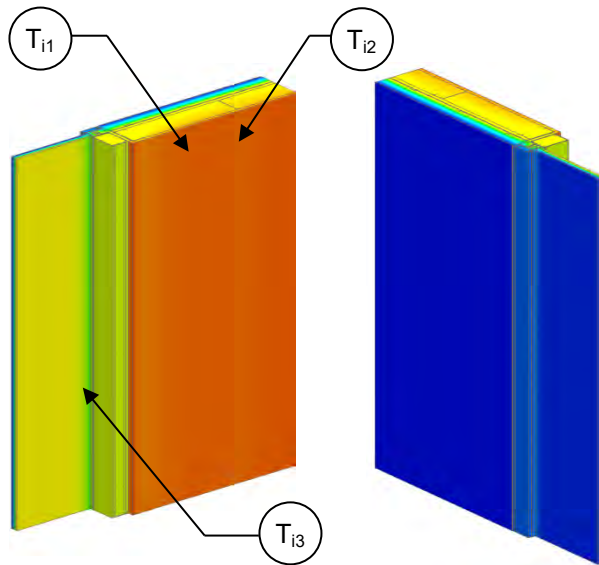

Thermal Performance Indicators

Assembly 1D (Nominal) R-Value	R _{1D}	R-2.7 (0.47 RSI) + exterior insulation
Transmittance / Resistance without Anomaly	U _g , U _w , R _w	"clear wall" U- and R-value for: g = curtain wall glazing w = steel stud assembly
Transmittance / Resistance	U, R	U- and R-values for overall assembly
Surface Temperature Index ¹	T _i	0 = exterior temperature 1 = interior temperature
Linear Transmittance	ψ	Incremental increase in transmittance per linear length of curtain wall transition

¹Assumptions and limitations for surface temperatures identified in ASHRAE 1365-RP

View from Interior View from Exterior

Nominal (1D) vs. Assembly Performance Indicators

Base Assembly – Wall

Exterior Insulation 1D R-Value (RSI)	R _{1D} ft ² ·hr·°F / Btu (m ² K / W)	R _w ft ² ·hr·°F / Btu (m ² K / W)	U _w Btu/ft ² ·hr ·°F (W/m ² K)
R-7.5 (1.32)	R-10.2 (1.80)	R-10.0 (1.76)	0.100 (0.57)
R-11.3 (1.98)	R-13.9 (2.46)	R-13.7 (2.41)	0.073 (0.41)
R-15 (2.64)	R-17.7 (3.12)	R-17.4 (3.06)	0.057 (0.33)

Base Assembly – Curtain Wall Glazing

U _{centre of glazing} Btu/ft ² ·hr ·°F (W/m ² K)	U _g Btu/ft ² ·hr ·°F (W/m ² K)
0.321 (1.82)	0.476 (2.7)

Curtain Wall Transition Linear Transmittance

Exterior Insulation 1D R-Value (RSI)	R ft ² ·hr·°F / Btu (m ² K / W)	U Btu/ft ² ·hr ·°F (W/m ² K)	ψ Btu/ft hr °F (W/m K)
R-7.5 (1.32)	R-4.0 (0.70)	0.250 (1.42)	0.045 (0.079)
R-11.3 (1.98)	R-4.3 (0.75)	0.234 (1.33)	0.049 (0.084)
R-15 (2.64)	R-4.4 (0.78)	0.225 (1.28)	0.051 (0.088)

Temperature Indices

	R7.5	R11.3	R15	
T _{i1}	0.62	0.64	0.65	Min T on sheathing, between studs
T _{i2}	0.81	0.86	0.89	Max T on sheathing, along studs
T _{i3}	0.56	0.56	0.57	Min T on frame, at edge of frame at glass

Detail 5.4.2

Exterior and Interior Insulated 3 5/8" x 1 5/8" Steel Stud (16" o.c.) Drained EIFS Wall Assembly with R-12 Batt Insulation in Stud Cavity – Conventional Curtain Wall Transition

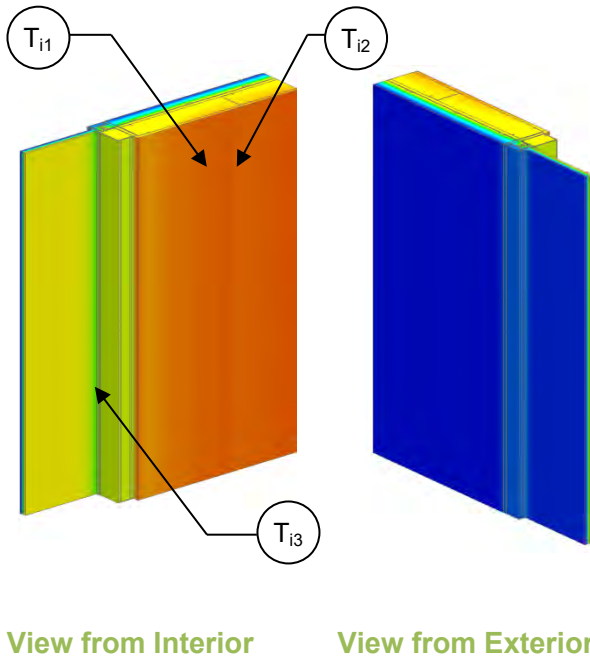

Thermal Performance Indicators

Assembly 1D (Nominal) R-Value	R_{1D}	R-14.2 (2.51 RSI) + exterior insulation
Transmittance / Resistance without Anomaly	U_g, U_w, R_w	“clear wall” U- and R-value for: g= curtain wall glazing w = steel stud assembly
Transmittance / Resistance	U, R	U- and R-values for overall assembly
Surface Temperature Index ¹	T_i	0 = exterior temperature 1 = interior temperature
Linear Transmittance	ψ	Incremental increase in transmittance per linear length of curtain wall transition

¹Assumptions and limitations for surface temperatures identified in ASHRAE 1365-RP

Nominal (1D) vs. Assembly Performance Indicators

Base Assembly – Wall

Exterior Insulation 1D R-Value (RSI)	R_{1D} ft ² ·hr·°F / Btu (m ² K / W)	R_w ft ² ·hr·°F / Btu (m ² K / W)	U_w Btu/ft ² ·hr ·°F (W/m ² K)
R-7.5 (1.32)	R-21.7 (3.83)	R-16.6 (2.93)	0.060 (0.34)
R-15 (2.64)	R-29.2 (5.15)	R-24.0 (4.23)	0.042 (0.24)

Base Assembly – Curtain Wall Glazing

$U_{\text{centre of glazing}}$ Btu/ft ² ·hr ·°F (W/m ² K)	U_g Btu/ft ² ·hr ·°F (W/m ² K)
0.321 (1.82)	0.476 (2.7)

Curtain Wall Transition Linear Transmittance

Exterior Insulation 1D R-Value (RSI)	R ft ² ·hr·°F / Btu (m ² K / W)	U Btu/ft ² ·hr ·°F (W/m ² K)	ψ Btu/ft hr °F (W/m K)
R-7.5 (1.32)	R-4.5 (0.79)	0.224 (1.27)	0.043 (0.074)
R-15 (2.64)	R-4.7 (0.83)	0.211 (1.20)	0.039 (0.067)

Temperature Indices

	R7.5	R15	
T_{i1}	0.40	0.57	Min T on sheathing, between studs
T_{i2}	0.66	0.77	Max T on sheathing, along studs
T_{i3}	0.55	0.56	Min T on frame, at edge of frame at glass

Detail 5.4.3

Exterior and Interior Insulated 3 5/8" x 1 5/8" Steel Stud (16" o.c.) Wall Assembly with R-12 Batt Insulation in Stud Cavity – Curtain Wall Transition

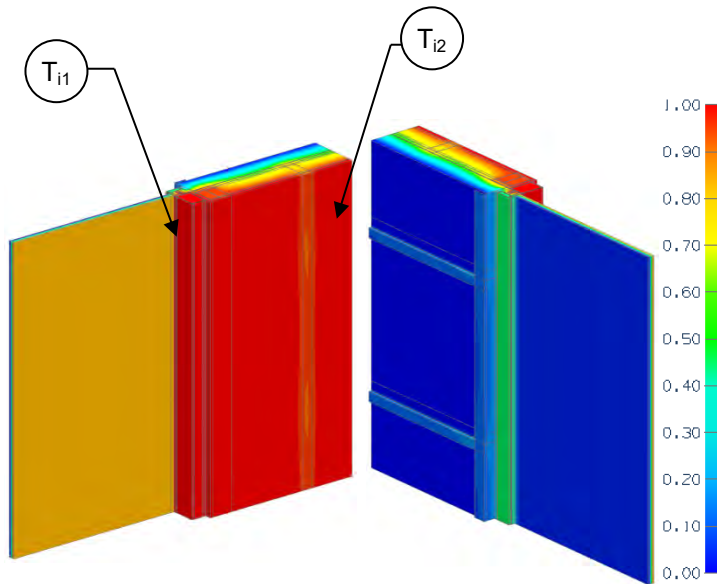

Thermal Performance Indicators

Assembly 1D (Nominal) R-Value	R_{1D}	R-13.9 (2.46 RSI) + exterior insulation
Transmittance / Resistance without Anomaly	U_g, U_w, R_w	"clear wall" U- and R-value for: g = curtain wall glazing w = steel stud assembly
Transmittance / Resistance	U, R	U and R-values for the assembly
Surface Temperature Index ¹	T_i	0 = exterior temperature 1 = interior temperature
Linear Transmittance	ψ	Incremental increase in transmittance per linear length of curtain wall transition

¹Assumptions and limitations for surface temperatures identified in ASHRAE 1365-RP

²Thermal image shown is for the Aerogel detail

View from Interior²

View from Exterior²

Scenario

Scenario	Curtain Wall Transition
A	Conventional
B	With Aerogel

Nominal (1D) vs. Assembly Performance Indicators

Base Assembly – Wall

Exterior Insulation 1D R-Value (RSI)	R_{1D} ft ² ·hr·°F / Btu (m ² K / W)	R_w ft ² ·hr·°F / Btu (m ² K / W)	U_w Btu/ft ² ·hr ·°F (W/m ² K)
R-15 (2.64)	R-28.9 (5.09)	R-18.3 (3.23)	0.054 (0.31)

Base Assembly – Curtain Wall Glazing

$U_{\text{centre of glass}}$ Btu/ft ² ·hr ·°F (W/m ² K)	U_g Btu/ft ² ·hr ·°F (W/m ² K)
0.321 (1.82)	0.429 (2.44)

Curtain Wall Transition Linear Transmittance

Scenario	R ft ² ·hr·°F / Btu (m ² K / W)	U Btu/ft ² ·hr ·°F (W/m ² K)	ψ Btu/ft hr °F (W/m K)
A	R-3.8 (0.67)	0.262 (1.49)	0.069 (0.12)
B	R-3.8 (0.68)	0.260 (1.48)	0.019 (0.03)

Temperature Indices

	A	B	
T_{i1}	0.32	0.33	Min T on glazing, along edge of glass
T_{i2}	0.77	0.77	Min T on sheathing, along Z-girts

Detail 5.4.4

Exterior and Interior Insulated 3 5/8" x 1 5/8" Steel Stud (16" o.c.) Wall Assembly with Horizontal Z-Girts (24" o.c.) Supporting Metal Cladding and R-12 Batt Insulation in Stud Cavity – Conventional Curtain Wall Intersection

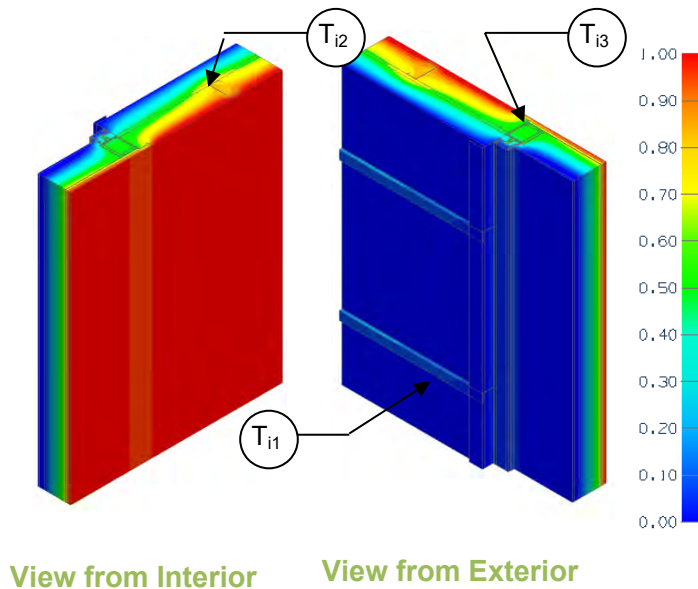

Thermal Performance Indicators

Assembly 1D (Nominal) R-Value	R_{1Dw} , R_{1Dcw}	Nominal thermal resistance of two base assemblies: w = wall cw = curtain wall
Transmittance / Resistance without Anomaly	U_{ow} , R_{ow} , U_{ocw} , R_{ocw}	"clear wall" U- and R-value for the two base assemblies
Transmittance / Resistance	U, R	U- and R-values for overall assembly
Surface Temperature Index ¹	T_i	0 = exterior temperature 1 = interior temperature
Linear Transmittance	ψ	Incremental increase in transmittance per linear length of transition joint

¹Assumptions and limitations for surface temperatures identified in ASHRAE 1365-RP

Nominal (1D) vs. Assembly Performance Indicators Base Assembly – Steel Stud Wall

Exterior Insulation 1D R-Value (RSI)	R_{1D} ft ² ·hr·°F / Btu (m ² K / W)	R_{ow} ft ² ·hr·°F / Btu (m ² K / W)	U_{ow} Btu/ft ² ·hr·°F (W/m ² K)
R-5 (0.88)	R-19.2 (3.38)	R-13.4 (2.36)	0.075 (0.42)
R-15 (2.64)	R-29.2 (5.14)	R-18.5 (3.25)	0.054 (0.31)
R-25 (4.40)	R-39.2 (6.90)	R-22.1 (3.90)	0.045 (0.26)

Base Assembly – Curtain Wall Spandrel

R_{1Dcw}^2 ft ² ·hr·°F / Btu (m ² K / W)	R_{ocw} ft ² ·hr·°F / Btu (m ² K / W)	U_{ocw} Btu/ft ² ·hr·°F (W/m ² K)
R-18.3 (3.22)	R-4.4 (0.78)	0.226 (1.29)

Transition Joint Linear Transmittance

Exterior Insulation 1D R-Value (RSI)	R ft ² ·hr·°F / Btu (m ² K / W)	U Btu/ft ² ·hr·°F (W/m ² K)	ψ Btu/ft hr °F (W/m K)
R-5 (0.88)	R-6.5 (1.14)	0.154 (0.88)	0.088 (0.151)
R-15 (2.64)	R-7.1 (1.25)	0.140 (0.80)	0.088 (0.151)
R-25 (4.40)	R-7.4 (1.30)	0.135 (0.77)	0.089 (0.155)

Temperature Indices

	R5	R15	R25	
T_{i1}	0.19	0.26	0.32	Min T on sheathing, along girt between studs, close to curtain wall
T_{i2}	0.66	0.78	0.82	Max T on sheathing, at studs, between z girts, away from curtain wall
T_{i3}	0.52	0.53	0.54	Min T on air cavity behind curtain wall, at mullion panel

Detail 5.4.5

Exterior Insulated Concrete Wall and Steel Stud Assembly Supporting Metal Cladding– Curtain Wall Transition Intersection

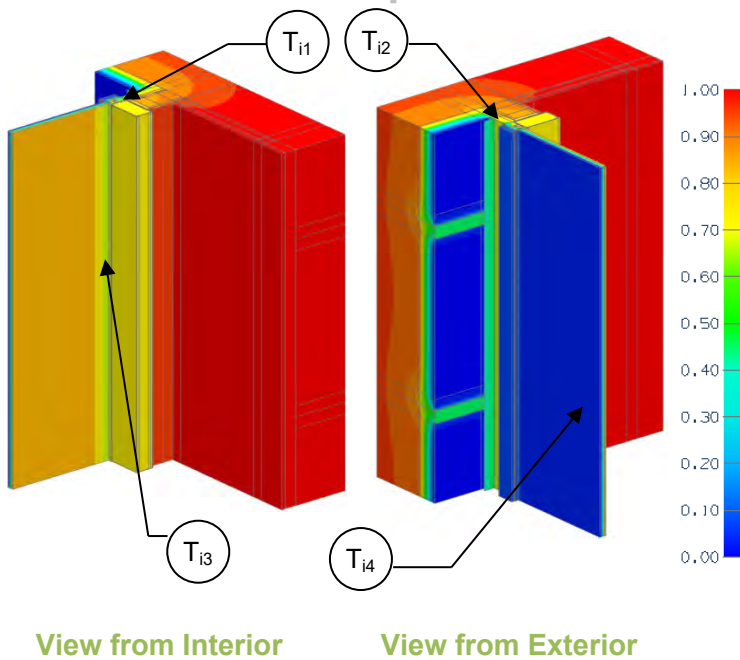

Thermal Performance Indicators

Assembly 1D (Nominal) R-Value	R_{1Dw}	R-1.9 (0.33 RSI) + exterior insulation
Transmittance / Resistance without Anomaly	U_g , U_w , R_w	“clear wall” U- and R-values for: g = curtain wall glazing w = concrete wall and steel stud assembly
Transmittance / Resistance	U , R	U- and R-values for overall assembly
Surface Temperature Index ¹	T_i	0 = exterior temperature 1 = interior temperature
Linear Transmittance	ψ	Incremental increase in transmittance per linear length of inside corner

¹Assumptions and limitations for surface temperatures identified in ASHRAE 1365-RP

Nominal (1D) vs. Assembly Performance Indicators

Base Assembly – Exterior Insulated Concrete Wall

Wall Exterior Insulation 1D R-Value (RSI)	R_{1Dw} ft ² ·hr·°F / Btu (m ² K / W)	R_w ft ² ·hr·°F / Btu (m ² K / W)	U_w Btu/ft ² ·hr·°F (W/m ² K)
R-15 (2.64)	R-16.9 (2.98)	R-9.5 (1.67)	0.105 (0.60)
R-20 (3.52)	R-21.9 (3.86)	R-10.9 (1.92)	0.092 (0.52)
R-25 (4.40)	R-26.9 (4.74)	R-12.0 (2.11)	0.083 (0.47)

Base Assembly – Curtain Wall Glazing

$U_{\text{centre of glass}}$ Btu/ft ² ·hr·°F (W/m ² K)	U_g Btu/ft ² ·hr·°F (W/m ² K)
0.305 (1.73)	0.441 (2.51)

Corner Linear Transmittance

Wall Exterior Insulation 1D R-Value (RSI)	R ft ² ·hr·°F / Btu (m ² K / W)	U Btu/ft ² ·hr·°F (W/m ² K)	ψ Btu/ft·hr·°F (W/m K)
R-15 (2.64)	R-2.5 (0.44)	0.405 (2.30)	0.159 (0.275)
R-20 (3.52)	R-2.5 (0.45)	0.394 (2.24)	0.144 (0.250)
R-25 (4.40)	R-2.6 (0.46)	0.384 (2.18)	0.128 (0.222)

Temperature Indices

	R15	R20	R25	
T_{i1}	0.70	0.70	0.71	Min T on sheathing, along jamb
T_{i2}	0.83	0.85	0.86	Max T on sheathing, between studs
T_{i3}	0.65	0.65	0.65	Min T on jamb, along glazing
T_{i4}	0.65	0.65	0.65	Min T on glazing, centre of glazing

Detail 5.4.6

Exterior Insulated Concrete Wall and Steel Stud Assembly Supporting Metal Cladding with Cavity Insulation– Curtain Wall Transition Intersection

Thermal Performance Indicators

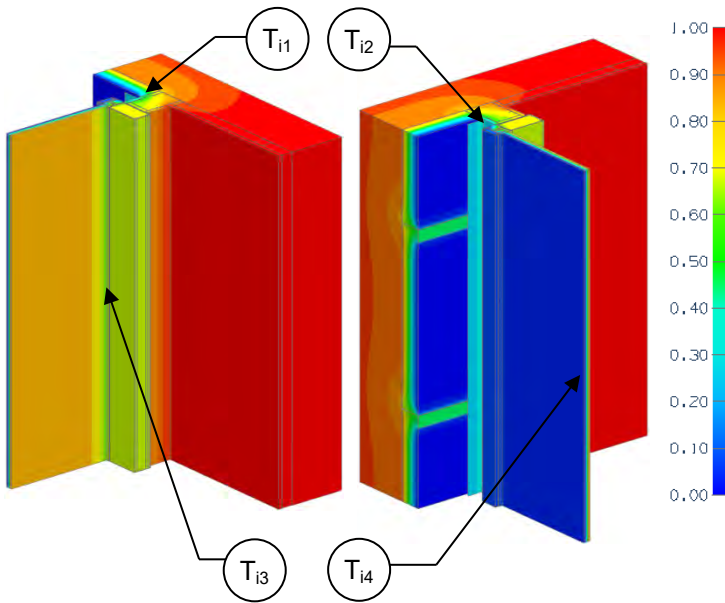

Assembly 1D (Nominal) R-Value	R_{1Dw}	R-1.9 (0.33 RSI) + exterior insulation
Transmittance / Resistance without Anomaly	$U_g,$ $U_w,$ R_w	“clear wall” U- and R-values for: g = curtain wall glazing w = concrete wall and steel stud assembly
Transmittance / Resistance	$U,$ R	U- and R-values for overall assembly
Surface Temperature Index ¹	T_i	0 = exterior temperature 1 = interior temperature
Linear Transmittance	ψ	Incremental increase in transmittance per linear length of inside corner

¹Assumptions and limitations for surface temperatures identified in ASHRAE 1365-RP

View from Interior View from Exterior

Nominal (1D) vs. Assembly Performance Indicators

Base Assembly – Exterior Insulated Concrete Wall

Wall Exterior Insulation 1D R-Value (RSI)	R_{1Dw} ft ² ·hr·°F / Btu (m ² K / W)	R_w ft ² ·hr·°F / Btu (m ² K / W)	U_w Btu/ft ² ·hr ·°F (W/m ² K)
R-15 (2.64)	R-16.9 (2.98)	R-9.5 (1.67)	0.105 (0.60)
R-20 (3.52)	R-21.9 (3.86)	R-10.9 (1.92)	0.092 (0.52)
R-25 (4.40)	R-26.9 (4.74)	R-12.0 (2.11)	0.083 (0.47)

Base Assembly – Curtain Wall Glazing

$U_{\text{centre of glazing}}$ Btu/ft ² ·hr ·°F (W/m ² K)	U_g Btu/ft ² ·hr ·°F (W/m ² K)
0.305 (1.73)	0.441 (2.51)

Corner Linear Transmittance

Wall Exterior Insulation 1D R-Value (RSI)	R ft ² ·hr·°F / Btu (m ² K / W)	U Btu/ft ² ·hr ·°F (W/m ² K)	ψ Btu/ft ·hr·°F (W/m K)
R-15 (2.64)	R-2.3 (0.40)	0.438 (2.49)	0.234 (0.404)
R-20 (3.52)	R-2.4 (0.42)	0.421 (2.39)	0.204 (0.353)
R-25 (4.40)	R-2.5 (0.44)	0.403 (2.29)	0.171 (0.296)

Temperature Indices

	R15	R20	R25	
T_{i1}	0.49	0.53	0.59	Min T on sheathing, between studs
T_{i2}	0.74	0.77	0.81	Max T on sheathing, beside concrete wall
T_{i3}	0.62	0.63	0.63	Min T on jamb, along glazing
T_{i4}	0.62	0.63	0.63	Min T on centre of glazing

Detail 5.5.1

Exterior Insulated 3 5/8" x 1 5/8" Steel Stud (16" o.c.) Drained EIFS Wall Assembly – Concrete Parapet & Slab Intersection

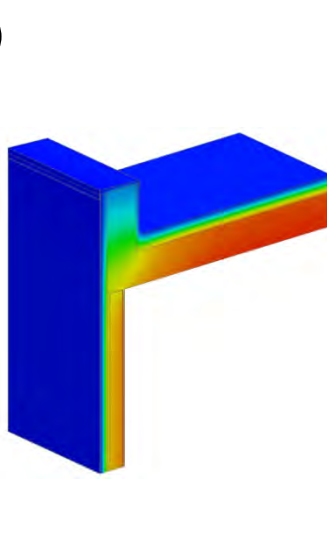
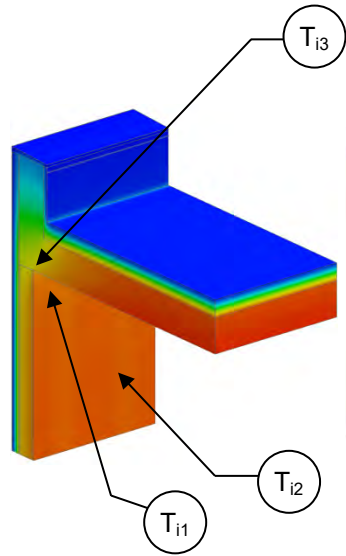

Thermal Performance Indicators

Assembly 1D (Nominal) R-Value	R _{1Dw}	R-2.7 (0.47 RSI) + exterior insulation
Transmittance / Resistance without Anomaly	U _r , R _r , U _w , R _w	"clear field" U- and R-values for: r = roof w = wall
Transmittance / Resistance	U, R	U- and R-values for overall assembly
Surface Temperature Index ¹	T _i	0 = exterior temperature 1 = interior temperature
Linear Transmittance	ψ	Incremental increase in transmittance per linear length of parapet

¹Assumptions and limitations for surface temperatures identified in ASHRAE 1365-RP

View from Interior

View from Exterior

Nominal (1D) vs. Assembly Performance Indicators

Base Assembly – Wall

Exterior Insulation 1D R-Value (RSI)	R _{1Dw} ft ² ·hr·°F / Btu (m ² K / W)	R _w ft ² ·hr·°F / Btu (m ² K / W)	U _w Btu/ft ² ·hr·°F (W/m ² K)
R-7.5 (1.32)	R-10.2 (1.80)	R-10.0 (1.76)	0.100 (0.57)
R-11.3 (1.98)	R-13.9 (2.46)	R-13.7 (2.41)	0.073 (0.41)
R-15 (2.64)	R-17.7 (3.12)	R-17.4 (3.06)	0.057 (0.33)

Base Assembly - Roof

Roof Insulation 1DR-Value (RSI)	R _r ft ² hr °F / Btu (m ² K / W)	U _r Btu/ft ² ·hr ·°F (W/m ² K)
R-20 (3.52)	R-21.9 (3.86)	0.046 (0.26)

Parapet Linear Transmittance

Exterior Insulation 1D R-Value (RSI)	R ft ² ·hr·°F / Btu (m ² K / W)	U Btu/ft ² ·hr ·°F (W/m ² K)	ψ Btu/ft hr °F (W/m K)
R-7.5 (1.32)	R-9.7 (1.7)	0.103 (0.59)	0.295 (0.511)
R-11.3 (1.98)	R-11.2 (1.97)	0.089 (0.51)	0.273 (0.472)
R-15 (2.64)	R-12.2 (2.15)	0.082 (0.47)	0.263 (0.456)

Temperature Indices

	R7.5	R11.3	R15	
T _{i1}	0.71	0.74	0.76	Min T on sheathing, at roof slab
T _{i2}	0.82	0.87	0.89	Max T on sheathing, along steel studs away from slab
T _{i3}	0.77	0.79	0.81	Min T on concrete ceiling, at drywall intersection, exposed to interior air

Detail 5.5.2

Exterior Insulated 3 5/8" x 1 5/8" Steel Stud (16" o.c.) Drained EIFS Wall Assembly – Insulated Concrete Parapet & Slab Intersection

Thermal Performance Indicators

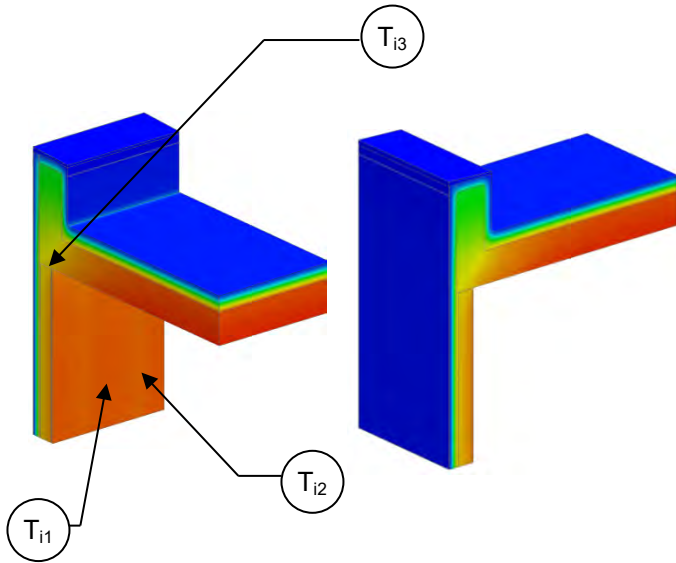

Assembly 1D (Nominal) R-Value	R_{1Dw}	R-2.7 (0.47 RSI) + exterior insulation
Transmittance / Resistance without Anomaly	U_r, R_r, U_w, R_w	“clear field” U- and R-values for: r = roof w = wall
Transmittance / Resistance	U, R	U- and R-values for overall assembly
Surface Temperature Index ¹	T_i	0 = exterior temperature 1 = interior temperature
Linear Transmittance	ψ	Incremental increase in transmittance per linear length of parapet

¹Assumptions and limitations for surface temperatures identified in ASHRAE 1365-RP

View from Interior

View from Exterior

Nominal (1D) vs. Assembly Performance Indicators

Base Assembly – Wall

Exterior Insulation 1D R-Value (RSI)	R_{1Dw} ft ² ·hr·°F / Btu (m ² K / W)	R_w ft ² ·hr·°F / Btu (m ² K / W)	U_w Btu/ft ² ·hr ·°F (W/m ² K)
R-7.5 (1.32)	R-10.2 (1.80)	R-10.0 (1.76)	0.100 (0.57)
R-11.3 (1.98)	R-13.9 (2.46)	R-13.7 (2.41)	0.073 (0.41)
R-15 (2.64)	R-17.7 (3.12)	R-17.4 (3.06)	0.057 (0.33)

Base Assembly - Roof

Roof Insulation 1D R-Value (RSI)	R_r ft ² hr °F / Btu (m ² K / W)	U_r Btu/ft ² ·hr ·°F (W/m ² K)
R-20 (3.52)	R-21.9 (3.86)	0.046 (0.26)

Parapet Linear Transmittance

Exterior Insulation 1D R-Value (RSI)	R ft ² ·hr·°F / Btu (m ² K / W)	U Btu/ft ² ·hr ·°F (W/m ² K)	ψ Btu/ft hr °F (W/m K)
R-7.5 (1.32)	R-10.6 (1.87)	0.094 (0.54)	0.220 (0.380)
R-11.3 (1.98)	R-13.0 (2.29)	0.077 (0.44)	0.168 (0.291)
R-15 (2.64)	R-14.9 (2.63)	0.067 (0.38)	0.138 (0.238)

Temperature Indices

	R7.5	R11.3	R15	
T_{i1}	0.75	0.81	0.84	Min T on sheathing, along roof slab
T_{i2}	0.82	0.87	0.89	Max T on sheathing, along steel studs away from slab
T_{i3}	0.81	0.85	0.87	Min T on concrete ceiling, at drywall intersection, exposed to interior air

Detail 5.5.3

Exterior and Interior Insulated 3 5/8" x 1 5/8" Steel Stud (16" o.c.) Drained EIFS Wall Assembly with R-12 Batt Insulation in Stud Cavity – Concrete Parapet & Slab Intersection

Thermal Performance Indicators

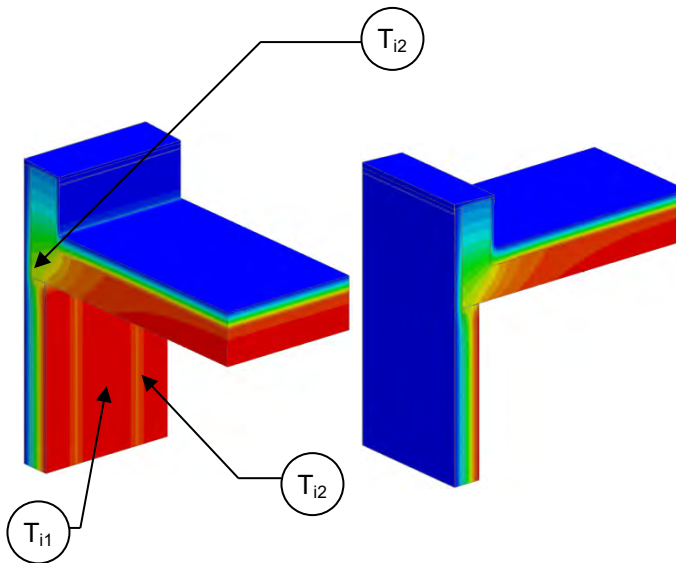

Assembly 1D (Nominal) R-Value	R_{1Dw}	R-14.2 (2.51 RSI) + exterior insulation
Transmittance / Resistance without Anomaly	U_r, R_r, U_w, R_w	“clear field” U- and R-values for: r = roof w = wall
Transmittance / Resistance	U, R	U- and R-values for overall assembly
Surface Temperature Index ¹	T_i	0 = exterior temperature 1 = interior temperature
Linear Transmittance	ψ	Incremental increase in transmittance per linear length of parapet

¹Assumptions and limitations for surface temperatures identified in ASHRAE 1365-RP

View from Interior

View from Exterior

Nominal (1D) vs. Assembly Performance Indicators

Base Assembly – Wall

Exterior Insulation 1D R-Value (RSI)	R_{1Dw} ft ² ·hr·°F / Btu (m ² K / W)	R_w ft ² ·hr·°F / Btu (m ² K / W)	U_w Btu/ft ² ·hr ·°F (W/m ² K)
R-7.5 (1.32)	R-21.7 (3.83)	R-16.6 (2.93)	0.060 (0.34)
R-15 (2.64)	R-29.2 (5.15)	R-24 (4.23)	0.042 (0.24)

Base Assembly - Roof

Roof Insulation 1D R-Value (RSI)	R_r ft ² hr °F / Btu (m ² K / W)	U_r Btu/ft ² ·hr ·°F (W/m ² K)
R-20 (3.52)	R-21.9 (3.86)	0.046 (0.26)

Parapet Linear Transmittance

Exterior Insulation 1D R-Value (RSI)	R ft ² ·hr·°F / Btu (m ² K / W)	U Btu/ft ² ·hr ·°F (W/m ² K)	ψ Btu/ft hr °F (W/m K)
R-7.5 (1.32)	R-11.5 (2.02)	0.087 (0.49)	0.297 (0.514)
R-15 (2.64)	R-13.3 (2.35)	0.075 (0.43)	0.260 (0.451)

Temperature Indices

	R7.5	R15	
T_{i1}	0.41	0.58	Min T on sheathing, between studs
T_{i2}	0.68	0.77	Max T on sheathing, along steel studs
T_{i3}	0.75	0.78	Min T on concrete ceiling, at drywall intersection, exposed to interior air

Detail 5.5.4

Exterior and Interior Insulated 3 5/8" x 1 5/8" Steel Stud (16" o.c.) Drained EIFS Wall Assembly with R-12 Batt Insulation in Stud Cavity – Insulated Concrete Parapet & Slab Intersection

Thermal Performance Indicators

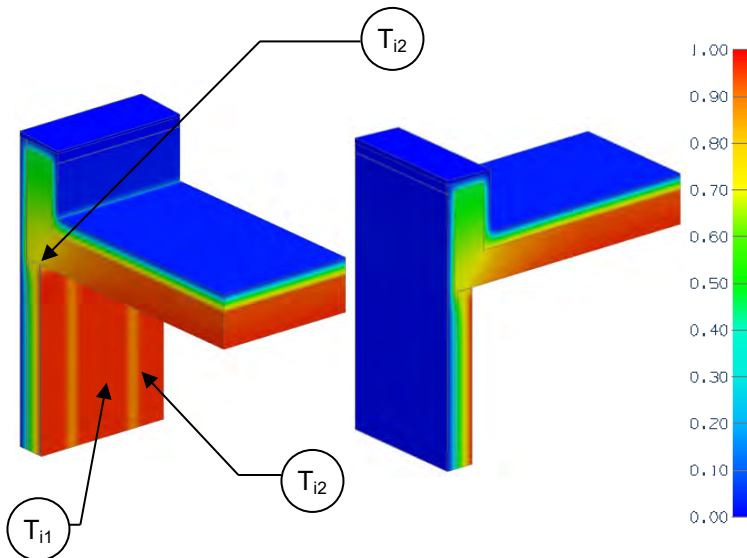

Assembly 1D (Nominal) R-Value	R_{1Dw}	R-14.2 (2.51 RSI) + exterior insulation
Transmittance / Resistance without Anomaly	$U_{or}, R_{or}, U_{ow}, R_{ow}$	“clear field” U- and R-values for: r = roof w = wall
Transmittance / Resistance	U, R	U- and R-values for overall assembly
Surface Temperature Index ¹	T_i	0 = exterior temperature 1 = interior temperature
Linear Transmittance	ψ	Incremental increase in transmittance per linear length of parapet

¹Assumptions and limitations for surface temperatures identified in ASHRAE 1365-RP

View from Interior

View from Exterior

Nominal (1D) vs. Assembly Performance Indicators

Base Assembly – Wall

Exterior Insulation 1D R-Value (RSI)	R_{1Dw} ft ² ·hr·°F / Btu (m ² K / W)	R_w ft ² ·hr·°F / Btu (m ² K / W)	U_w Btu/ft ² ·hr ·°F (W/m ² K)
R-7.5 (1.32)	R-21.7 (3.83)	R-16.6 (2.93)	0.060 (0.34)
R-15 (2.64)	R-29.2 (5.15)	R-24.0 (4.23)	0.042 (0.24)

Base Assembly - Roof

Roof Insulation 1D R-Value (RSI)	R_r ft ² hr °F / Btu (m ² K / W)	U_r Btu/ft ² ·hr ·°F (W/m ² K)
R-20 (3.52)	R-21.9 (3.86)	0.046 (0.26)

Parapet Linear Transmittance

Exterior Insulation 1D R-Value (RSI)	R ft ² ·hr·°F / Btu (m ² K / W)	U Btu/ft ² ·hr ·°F (W/m ² K)	ψ Btu/ft hr °F (W/m K)
R-7.5 (1.32)	R-12.7 (2.24)	0.078 (0.45)	0.225 (0.390)
R-15 (2.64)	R-15.1 (2.66)	0.066 (0.38)	0.186 (0.323)

Temperature Indices

	R7.5	R15	
T_{i1}	0.41	0.51	Min T on sheathing, between studs
T_{i2}	0.72	0.78	Max T on sheathing, along steel studs
T_{i3}	0.75	0.84	Min T on concrete ceiling, at drywall intersection, exposed to interior air

Detail 5.5.5

Exterior Insulated 3 5/8" x 1 5/8" Steel Stud (16" O.C.) Wall Assembly with Horizontal Z-Girts (24" O.C.) Supporting Metal Cladding – Concrete Parapet & Slab Intersection

Thermal Performance Indicators

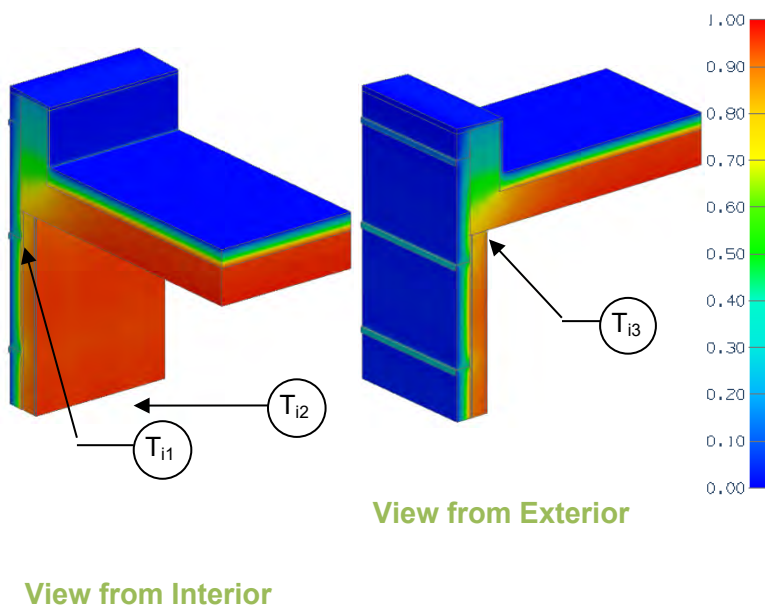

Assembly 1D (Nominal) R-Value	R_{1Dw}	R-3.2 (0.56 RSI) + exterior insulation
Transmittance / Resistance without Anomaly	U_r, R_r, U_w, R_w	“clear field” U- and R-values for two base assemblies: r = insulated roof w = steel stud wall assembly with horizontal z girts
Transmittance / Resistance	U, R	U- and R-values for overall assembly
Surface Temperature Index ¹	T_i	0 = exterior temperature 1 = interior temperature
Linear Transmittance	ψ	Incremental increase in transmittance per linear length of parapet

¹Assumptions and limitations for surface temperatures identified in ASHRAE 1365-RP

Nominal (1D) vs. Assembly Performance Indicators Base Assembly – Wall

Wall Exterior Insulation 1D R-Value (RSI)	R_{1Dw} ft ² ·hr·°F / Btu (m ² K / W)	R_w ft ² ·hr·°F / Btu (m ² K / W)	U_w Btu/ft ² ·hr ·°F (W/m ² K)
R-5 (0.88)	R-8.2 (1.44)	R-6.8 (1.21)	0.146 (0.83)
R-10 (1.76)	R-13.2 (2.32)	R-9.4 (1.66)	0.106 (0.60)
R-15 (2.64)	R-18.2 (3.20)	R-11.3 (1.99)	0.088 (0.50)
R-20 (3.52)	R-23.2 (4.08)	R-13.1 (2.31)	0.076 (0.43)
R-25 (4.40)	R-28.2 (4.96)	R-14.5 (2.56)	0.069 (0.39)

Base Assembly - Roof

Roof Insulation 1D R-Value (RSI)	R_r ft ² hr °F / Btu (m ² K / W)	U_r Btu/ft ² ·hr ·°F (W/m ² K)
R-20 (3.52)	R-21.9 (3.86)	0.046 (0.26)

Parapet Linear Transmittance

Wall Exterior Insulation 1D R-Value (RSI)	R ft ² ·hr·°F / Btu (m ² K / W)	U Btu/ft ² ·hr ·°F (W/m ² K)	ψ Btu/ft hr °F (W/m K)
R-5 (0.88)	R-8.0 (1.40)	0.125 (0.71)	0.313 (0.541)
R-10 (1.76)	R-9.5 (1.67)	0.105 (0.60)	0.284 (0.491)
R-15 (2.64)	R-10.4 (1.83)	0.096 (0.55)	0.271 (0.468)
R-20 (3.52)	R-11.0 (1.94)	0.091 (0.52)	0.266 (0.460)
R-25 (4.40)	R-11.5 (2.02)	0.087 (0.49)	0.261 (0.452)

Temperature Indices

	R5	R10	R15	R20	R25	
T_{i1}	0.62	0.68	0.71	0.73	0.75	Min T on sheathing, along girt between studs, close to ceiling
T_{i2}	0.75	0.83	0.86	0.88	0.90	Max T on sheathing, at studs, away from ceiling
T_{i3}	0.74	0.77	0.79	0.80	0.80	Min T on ceiling, at gypsum and studs

Detail 5.5.6

Exterior and Interior Insulated 3 5/8" x 1 5/8" Steel Stud (16" o.c.) Wall Assembly with Horizontal Z-girts (24" o.c.) Supporting Metal Cladding and R-12 Batt Insulation in Stud Cavity – Concrete Parapet and Slab Intersection

Thermal Performance Indicators

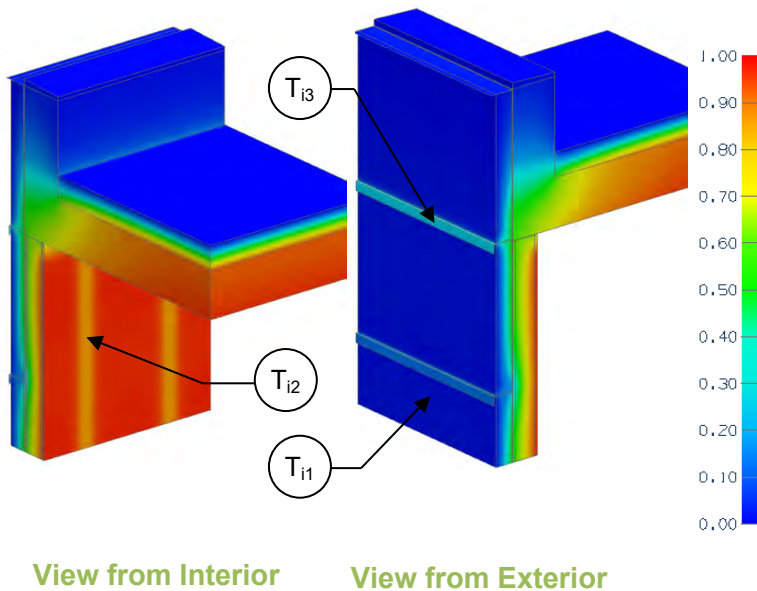

Assembly 1D (Nominal) R-Value	R_{1Dw}	R-14.2 (2.50 RSI) + exterior insulation
Transmittance / Resistance without Anomaly	U_r, R_r, U_w, R_w	“clear field” U- and R-values for: r = insulated roof w = steel stud wall assembly with horizontal z girts
Transmittance / Resistance	U, R	U- and R-values for overall assembly
Surface Temperature Index ¹	T_i	0 = exterior temperature 1 = interior temperature
Linear Transmittance	ψ	Incremental increase in transmittance per linear length of parapet

¹Assumptions and limitations for surface temperatures identified in ASHRAE 1365-RP

Nominal (1D) vs. Assembly Performance Indicators

Base Assembly – External Insulated Steel Stud Wall

Exterior Insulation 1D R-Value (RSI)	R_{1Dw} ft ² ·hr·°F / Btu (m ² K / W)	R_w ft ² ·hr·°F / Btu (m ² K / W)	U_w Btu/ft ² ·hr ·°F (W/m ² K)
R-10 (1.76)	R-24.2 (4.26)	R-16.3 (2.87)	0.061 (0.35)
R-15 (2.64)	R-29.2 (5.14)	R-18.5 (3.25)	0.054 (0.31)

Base Assembly – Roof

Roof Insulation 1D R-Value (RSI)	R_r ft ² ·hr·°F / Btu (m ² K / W)	U_r Btu/ft ² ·hr ·°F (W/m ² K)
R-20 (3.52)	R-21.9 (3.86)	0.046 (0.26)

Parapet Linear Transmittance

Exterior Insulation 1D R-Value (RSI)	R ft ² ·hr·°F / Btu (m ² K / W)	U Btu/ft ² ·hr ·°F (W/m ² K)	ψ Btu/ft ·hr ·°F (W/m K)
R-10 (1.76)	R-7.9 (1.39)	0.127 (0.72)	0.448 (0.776)
R-15 (2.64)	R-8.2 (1.44)	0.122 (0.70)	0.444 (0.768)

Temperature Indices

	R10	R15	
T_{i1}	0.30	0.34	Min T on sheathing, along girt between studs away from ceiling
T_{i2}	0.62	0.65	Max T on sheathing, at studs, between girts
T_{i3}	0.51	0.55	Min T on ceiling, at exterior gypsum between studs

Detail 5.5.7

Exterior and Interior Insulated 3 5/8" x 1 5/8" Steel Stud (16" o.c.) Wall Assembly with Vertical Z Girts (16" o.c.) Supporting Stucco Cladding and R-12 Batt Insulation in Stud Cavity – Concrete Parapet & Slab Intersection

Thermal Performance Indicators

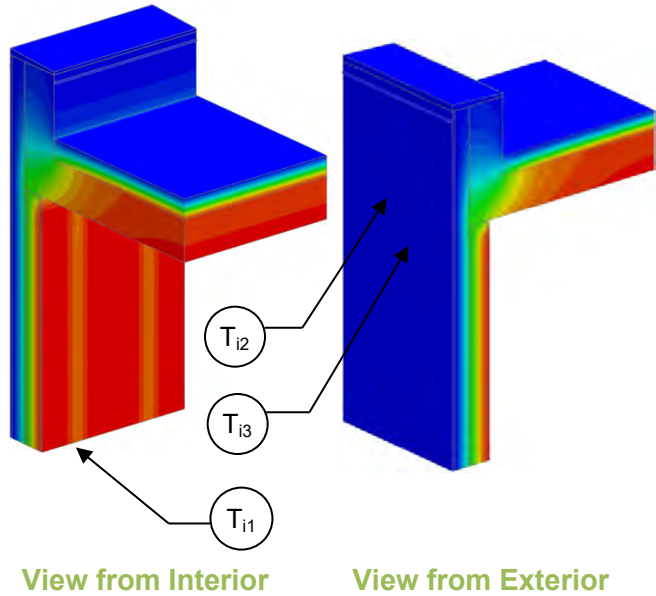

Assembly 1D (Nominal) R-Value	R_{1Dw}	R-14.5 (2.55 RSI) + exterior insulation
Transmittance / Resistance without Anomaly	U_r, R_r, U_w, R_w	"clear field" U- and R-values for two base assemblies: r = insulated roof w = steel stud wall assembly with horizontal z girts
Transmittance / Resistance	U, R	U- and R-values for overall assembly
Surface Temperature Index ¹	T_i	0 = exterior temperature 1 = interior temperature
Linear Transmittance	ψ	Incremental increase in transmittance per linear length of parapet

¹Assumptions and limitations for surface temperatures identified in ASHRAE 1365-RP

Nominal (1D) vs. Assembly Performance Indicators

Base Assembly – Wall

Wall Exterior Insulation 1D R-Value (RSI)	R_{1Dw} ft ² ·hr·°F / Btu (m ² K / W)	R_w ft ² ·hr·°F / Btu (m ² K / W)	U_w Btu/ft ² ·hr ·°F (W/m ² K)
R-10 (1.76)	R-24.5 (4.31)	R-13.0 (2.29)	0.077 (0.44)
R-15 (2.64)	R-29.5 (5.20)	R-14.1 (2.49)	0.071 (0.40)

Base Assembly – Roof

Roof Insulation 1D R-Value (RSI)	R_r ft ² hr °F / Btu (m ² K / W)	U_r Btu/ft ² ·hr ·°F (W/m ² K)
R-20 (3.52)	R-21.9 (3.86)	0.046 (0.26)

Parapet Linear Transmittance

Wall Exterior Insulation 1D R-Value (RSI)	R ft ² ·hr·°F / Btu (m ² K / W)	U Btu/ft ² ·hr ·°F (W/m ² K)	ψ Btu/ft ·hr·°F (W/m K)
R-10 (1.76)	R-7.8 (1.37)	0.129 (0.73)	0.454 (0.785)
R-15 (2.64)	R-8.1 (1.42)	0.124 (0.70)	0.445 (0.770)

Temperature Indices

	R10	R15	
T_{i1}	0.39	0.44	Min T on sheathing, along studs, away from ceiling
T_{i2}	0.55	0.56	Max T on sheathing, along track, behind braces
T_{i3}	0.64	0.65	Min T on ceiling, at gypsum and studs

Detail 5.5.8

Exterior and Interior Insulated 3 5/8" x 1 5/8" Steel Stud (16" o.c.) Wall Assembly with Intermittent Vertical Z Girts (16" o.c.) Supporting Metal Cladding and R-12 Batt Insulation in Stud Cavity –Concrete Roof Deck at Continuous Concrete Parapet

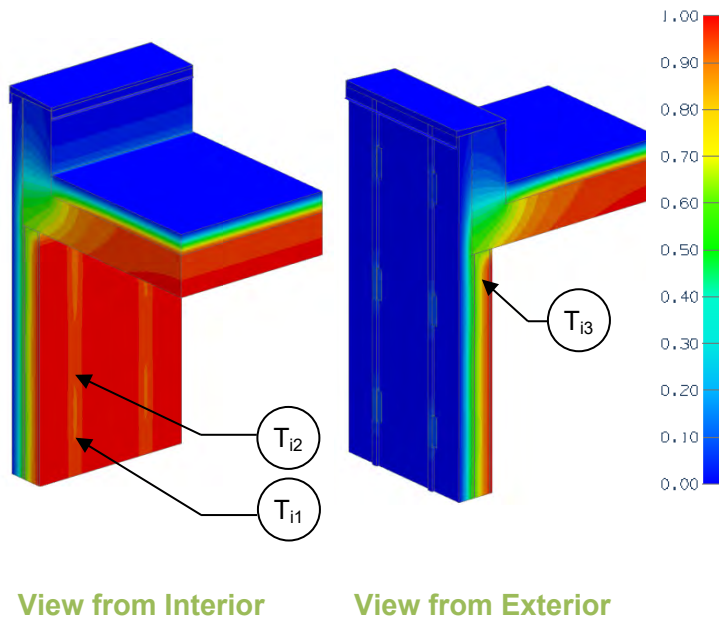

Thermal Performance Indicators

Assembly 1D (Nominal) R-Value	R_{1D}	R-14.4 (2.54 RSI) + exterior insulation
Transmittance / Resistance without Anomaly	U_r , R_r , U_w , R_w	"clear field" U- and R-values for two base assemblies: r = insulated roof w = steel stud wall assembly with horizontal z girts
Transmittance / Resistance	U, R	U and R-values for the overall assembly
Surface Temperature Index ¹	T_i	0 = exterior temperature 1 = interior temperature
Linear Transmittance	ψ	Incremental increase in transmittance per linear length of parapet

¹Assumptions and limitations for surface temperatures identified in ASHRAE 1365-RP

Nominal (1D) vs. Assembly Performance Indicators

Base Assembly – Wall

Wall Exterior Insulation 1D R-Value (RSI)	R_{1D} ft ² ·hr·°F / Btu (m ² K / W)	R_w ft ² ·hr·°F / Btu (m ² K / W)	U_w Btu/ft ² ·hr ·°F (W/m ² K)
R-15 (2.64)	R-29.4 (5.18)	R-18.9 (3.33)	0.053 (0.30)

Base Assembly - Roof

Roof Exterior Insulation 1D R-Value (RSI)	R_w ft ² ·hr·°F / Btu (m ² K / W)	U_w Btu/ft ² ·hr ·°F (W/m ² K)
R-20 (3.52)	R-21.9 (3.86)	0.046 (0.26)

Parapet Linear Transmittance

Wall Exterior Insulation 1D R-Value (RSI)	R ft ² ·hr·°F / Btu (m ² K / W)	U Btu/ft ² ·hr ·°F (W/m ² K)	ψ Btu/ft hr °F (W/m K)
R-15 (2.64)	R-9.6 (1.69)	0.104 (0.59)	0.396 (0.686)

Temperature Indices

T_{i1}	0.52	Min T on sheathing away from roof slab, at clip
T_{i2}	0.72	Max T on sheathing away from roof slab, between clips at stud
T_{i3}	0.69	Min T on roof slab exposed to interior air, at gypsum between studs

Detail 5.5.9

Exterior and Interior Insulated 3 5/8" x 1 5/8" Steel Stud (16" o.c.) Wall Assembly with Intermittent Vertical Z Girts (16" o.c.) Supporting Metal Cladding and R-12 Batt Insulation in Stud Cavity – Concrete Roof Deck at Isokorb AXT1 Thermally Broken Concrete Parapet

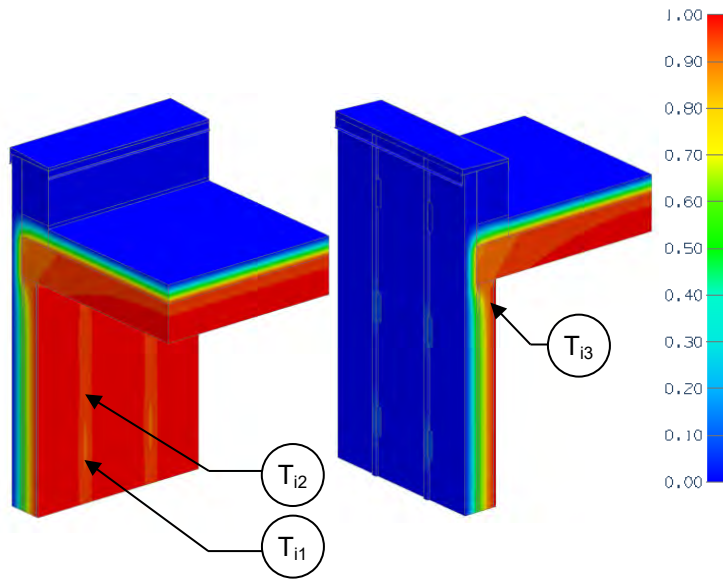

View from Interior

View from Exterior

Thermal Performance Indicators

Assembly 1D (Nominal) R-Value	R_{1Dw}	R-14.3 (2.52 RSI) + exterior insulation
Transmittance / Resistance without Anomaly	U_r, R_r, U_w, R_w	"clear field" U- and R-values for: r = insulated roof w = steel stud wall assembly with horizontal z girts
Transmittance / Resistance	U, R	U and R-values for the overall assembly
Surface Temperature Index ¹	T_i	0 = exterior temperature 1 = interior temperature
Linear Transmittance	ψ	Incremental increase in transmittance per linear length of parapet

¹Assumptions and limitations for surface temperatures identified in ASHRAE 1365-RP

Nominal (1D) vs. Assembly Performance Indicators

Base Assembly – Wall

Wall Exterior Insulation 1D R-Value (RSI)	R_{1Dw} ft ² ·hr·°F / Btu (m ² K / W)	R_w ft ² ·hr·°F / Btu (m ² K / W)	U_w Btu/ft ² ·hr·°F (W/m ² K)
R-15 (2.64)	R-29.3 (5.16)	R-18.9 (3.33)	0.053 (0.30)

Base Assembly - Roof

Roof Exterior Insulation 1D R-Value (RSI)	R_r ft ² ·hr·°F / Btu (m ² K / W)	U_r Btu/ft ² ·hr·°F (W/m ² K)
R-20 (3.52)	R-21.9 (3.86)	0.046 (0.26)

Parapet Linear Transmittance

Wall Exterior Insulation 1D R-Value (RSI)	R ft ² ·hr·°F / Btu (m ² K / W)	U Btu/ft ² ·hr·°F (W/m ² K)	ψ Btu/ft hr °F (W/m K)
R-15 (2.64)	R-17.4 (3.06)	0.058 (0.33)	0.058 (0.100)

Temperature Indices

T_{i1}	0.52	Min T on sheathing away from roof slab, at clip
T_{i2}	0.72	Max T on sheathing away from roof slab, between clips at stud
T_{i3}	0.90	Min T on roof slab exposed to interior air, at gypsum between studs

Detail 5.5.10

Exterior and Interior Insulated 3 5/8" x 1 5/8" Steel Stud (16" o.c) Wall Assembly with Horizontal Z-Girts (24" o.c.) Supporting Metal Cladding and R-12 Batt Insulation in Stud Cavity – Steel Roof Deck with Open Web Steel Joist & Parapet Intersection

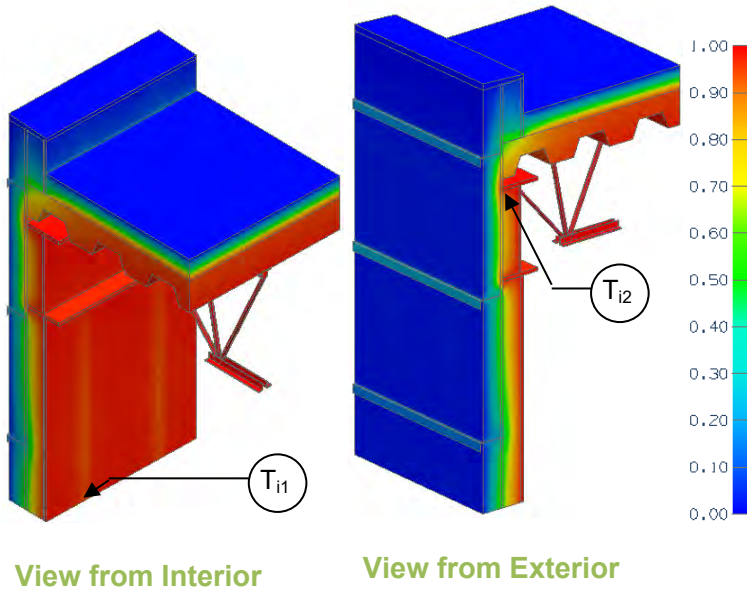

Thermal Performance Indicators

Assembly 1D (Nominal) R-Value	R_{1Dw}	R-14.2 (2.50 RSI) + exterior insulation
Transmittance / Resistance without Anomaly	U_r , R_r , U_w , R_w	"clear field" U- and R-values for: r = insulated roof w = steel stud wall assembly with horizontal z girts
Transmittance / Resistance	U, R	U and R-values for the overall assembly
Surface Temperature Index ¹	T_i	0 = exterior temperature 1 = interior temperature
Linear Transmittance	ψ	Incremental increase in transmittance per linear length of parapet

¹Assumptions and limitations for surface temperatures identified in ASHRAE 1365-RP

Nominal (1D) vs. Assembly Performance Indicators

Base Assembly – Wall

Wall Exterior Insulation 1D R-Value (RSI)	R_{1D} ft ² ·hr·°F / Btu (m ² K / W)	R_w ft ² ·hr·°F / Btu (m ² K / W)	U_w Btu/ft ² ·hr ·°F (W/m ² K)
R-5 (0.88)	R-19.2 (3.38)	R-13.4 (2.36)	0.075 (0.42)
R-10 (1.76)	R-24.2 (4.26)	R-16.3 (2.87)	0.061 (0.35)
R-15 (2.64)	R-29.2 (5.14)	R-18.5 (3.25)	0.054 (0.31)
R-20 (3.52)	R-34.2 (6.02)	R-20.5 (3.61)	0.049 (0.28)
R-25 (4.40)	R-39.2 (6.90)	R-22.1 (3.90)	0.045 (0.26)

Base Assembly - Roof

Roof Exterior Insulation 1D R-Value (RSI)	R_r ft ² ·hr·°F / Btu (m ² K / W)	U_r Btu/ft ² ·hr ·°F (W/m ² K)
R-20 (3.52)	R-21.9 (3.86)	0.046 (0.26)

Parapet Linear Transmittance

Wall Exterior Insulation 1D R-Value (RSI)	R ft ² ·hr·°F / Btu (m ² K / W)	U Btu/ft ² ·hr ·°F (W/m ² K)	ψ Btu/ft hr °F (W/m K)
R-5 (0.88)	R-9.8 (1.73)	0.102 (0.58)	0.289 (0.500)
R-10 (1.76)	R-11.7 (2.05)	0.086 (0.49)	0.227 (0.393)
R-15 (2.64)	R-12.8 (2.26)	0.078 (0.44)	0.201 (0.348)
R-20 (3.52)	R-13.7 (2.41)	0.073 (0.41)	0.187 (0.324)
R-25 (4.40)	R-14.5 (2.54)	0.069 (0.39)	0.176 (0.304)

Temperature Indices

	R5	R10	R15	R20	R25	
T_{i1}	0.27	0.35	0.41	0.45	0.48	Min T on sheathing, along studs between girts
T_{i2}	0.80	0.84	0.96	0.96	0.97	Min T on interior surfaces, at sheathing, away from joist

Detail 5.5.11

Exterior and Interior Insulated 3 5/8" x 1 5/8" Steel Stud (16" o.c) Wall Assembly with Horizontal Z-Girts (24" o.c.) Supporting Metal Cladding and R-12 Batt Insulation in Stud Cavity – Steel Roof Deck with Open Web Steel Joist & Parapet Intersection with Thermal Break under Parapet Stud Cavity

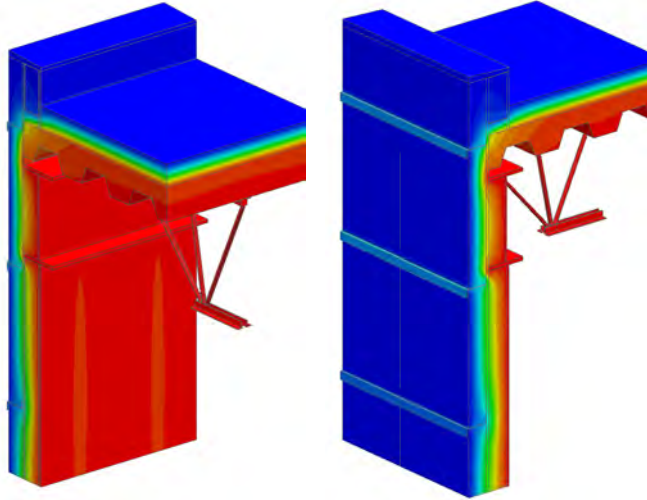

View from Interior

View from Exterior

Thermal Performance Indicators

Assembly 1D (Nominal) R-Value	R_{1Dw}	R-14.2 (2.50 RSI) + exterior insulation
Transmittance / Resistance without Anomaly	U_r , R_r , U_w , R_w	“clear field” U- and R-values for: r = insulated roof w = steel stud wall assembly with horizontal z girts
Transmittance / Resistance	U, R	U and R-values for the overall assembly
Linear Transmittance	ψ	Incremental increase in transmittance per linear length of parapet

¹Assumptions and limitations for surface temperatures identified in ASHRAE 1365-RP

Nominal (1D) vs. Assembly Performance Indicators

Base Assembly – Wall

Wall Exterior Insulation 1D R-Value (RSI)	R_{1D} ft ² ·hr·°F / Btu (m ² K / W)	R_w ft ² ·hr·°F / Btu (m ² K / W)	U_w Btu/ft ² ·hr ·°F (W/m ² K)
R-15 (2.64)	R-29.2 (5.14)	R-18.5 (3.25)	0.054 (0.31)

Base Assembly - Roof

Roof Exterior Insulation 1D R-Value (RSI)	R_r ft ² ·hr·°F / Btu (m ² K / W)	U_r Btu/ft ² ·hr ·°F (W/m ² K)
R-20 (3.52)	R-21.9 (3.86)	0.046 (0.26)

Parapet Linear Transmittance

Wall Exterior Insulation 1D R-Value (RSI)	R ft ² ·hr·°F / Btu (m ² K / W)	U Btu/ft ² ·hr ·°F (W/m ² K)	ψ Btu/ft hr °F (W/m K)
R-15 (2.64)	R-14.0 (2.47)	0.071 (0.39)	0.151 (0.260)

Detail 5.5.12

Owens Corning Exterior Insulated 6" x 1 5/8" Steel Stud (16" o.c.) Wall Assembly with Thermally Isolated Vertical Brackets and Rail System (24" o.c.) Supporting Metal Cladding – Concrete Parapet and Roof Intersection

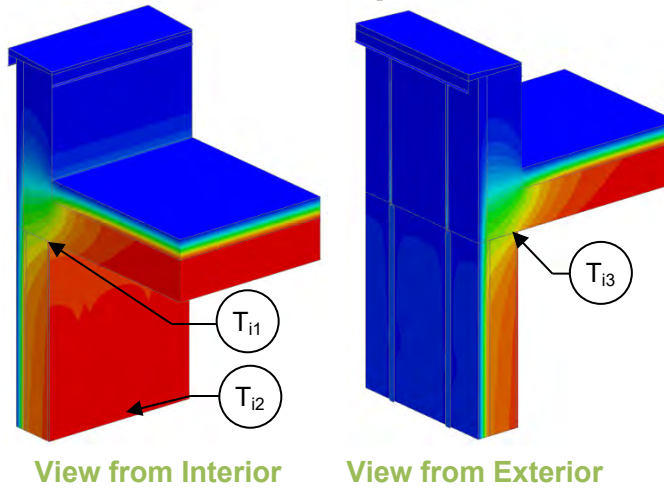

Thermal Performance Indicators

Assembly 1D (Nominal) R-Value	R_{1D}	R-3.3 (0.58 RSI) + exterior insulation
Transmittance / Resistance without Anomaly	U_r, R_r, U_w, R_w	"clear field" U- and R-values for: r = roof w = wall
Transmittance / Resistance	U, R	U- and R-values for overall assembly
Surface Temperature Index ¹	T_i	0 = exterior temperature 1 = interior temperature
Linear Transmittance	ψ	Incremental increase in transmittance per length of parapet

¹Assumptions and limitations for surface temperatures identified in ASHRAE 1365-RP

Nominal (1D) vs. Assembly Performance Indicators Base Assembly – Wall

Exterior Insulation 1D R-Value (RSI)	R_{1Dw} ft ² ·hr·°F / Btu (m ² K / W)	R_w ft ² ·hr·°F / Btu (m ² K / W)	U_w Btu/ft ² ·hr ·°F (W/m ² K)
R-8.4 (1.48)	R-11.7 (2.06)	R-10.0 (1.77)	0.100 (0.57)
R-21.0 (3.70)	R-24.3 (4.28)	R-17.6 (3.10)	0.057 (0.32)

Base Assembly - Roof

Roof Insulation 1DR-Value (RSI)	R_r ft ² hr °F / Btu (m ² K / W)	U_r Btu/ft ² ·hr ·°F (W/m ² K)
R-20 (3.52)	R-21.9 (3.86)	0.046 (0.26)

Parapet Linear Transmittance

Exterior Insulation 1D R-Value (RSI)	R ft ² ·hr·°F / Btu (m ² K / W)	U Btu/ft ² ·hr ·°F (W/m ² K)	ψ Btu/ft hr °F (W/m K)
R-8.4 (1.48)	R-7.2 (1.28)	0.138 (0.78)	0.405 (0.701)
R-21.0 (3.70)	R-8.6 (1.51)	0.117 (0.66)	0.407 (0.704)

Temperature Indices

	R8.4	R21	
T_{i1}	0.58	0.62	Min T on sheathing at roof slab, at clip
T_{i2}	0.80	0.89	Max T on sheathing away from roof slab, between studs
T_{i3}	0.72	0.74	Min T on roof slab exposed to interior air, at gypsum between studs

Detail 5.5.13

Exterior and Interior Insulated 6" x 1 5/8" Steel Stud (16" o.c.) Wall Assembly with Thermally Isolated Vertical Brackets and Rail System (24" o.c.) Supporting Metal Cladding and Owens Corning R-20 Batt in Stud Cavity – Concrete Parapet and Roof Intersection

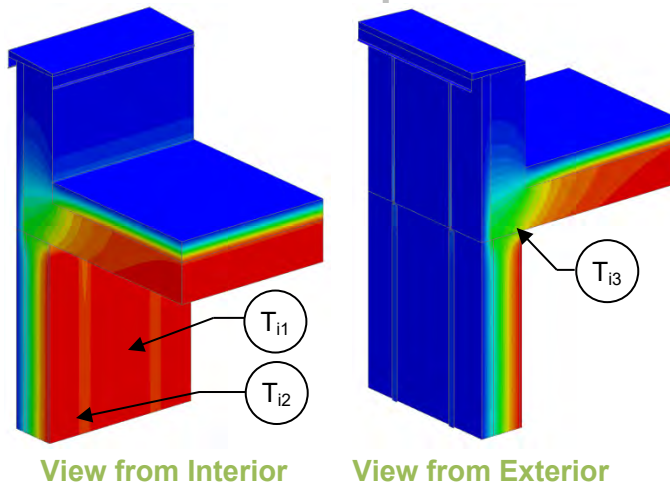

Thermal Performance Indicators

Assembly 1D (Nominal) R-Value	R_{1D}	R-22.4 (3.94 RSI) + exterior insulation
Transmittance / Resistance without Anomaly	U_r , R_r , U_w , R_w	"clear field" U- and R-values for: r = roof w = wall
Transmittance / Resistance	U, R	U- and R-values for overall assembly
Surface Temperature Index ¹	T_i	0 = exterior temperature 1 = interior temperature
Linear Transmittance	ψ	Incremental increase in transmittance per length of parapet

¹Assumptions and limitations for surface temperatures identified in ASHRAE 1365-RP

Nominal (1D) vs. Assembly Performance Indicators

Base Assembly – Wall

Exterior Insulation 1D R-Value (RSI)	R_{1Dw} ft ² ·hr·°F / Btu (m ² K / W)	R_w ft ² ·hr·°F / Btu (m ² K / W)	U_w Btu/ft ² ·hr ·°F (W/m ² K)
R-8.4 (1.48)	R-30.8 (5.42)	R-18.3 (3.23)	0.055 (0.31)
R-21.0 (3.70)	R-43.4 (7.64)	R-25.8 (4.54)	0.039 (0.22)

Base Assembly - Roof

Roof Insulation 1DR-Value (RSI)	R_r ft ² hr °F / Btu (m ² K / W)	U_r Btu/ft ² ·hr ·°F (W/m ² K)
R-20 (3.52)	R-21.9 (3.86)	0.046 (0.26)

Parapet Linear Transmittance

Exterior Insulation 1D R-Value (RSI)	R ft ² ·hr·°F / Btu (m ² K / W)	U Btu/ft ² ·hr ·°F (W/m ² K)	ψ Btu/ft hr °F (W/m K)
R-8.4 (1.48)	R-8.9 (1.57)	0.112 (0.64)	0.388 (0.671)
R-21.0 (3.70)	R-9.7 (1.71)	0.103 (0.59)	0.379 (0.657)

Temperature Indices

	R8.4	R21	
T_{i1}	0.35	0.54	Min T on sheathing at roof slab, away from roof slab, between studs at clip
T_{i2}	0.60	0.73	Max T on sheathing away from roof slab, at studs
T_{i3}	0.67	0.69	Min T on roof slab exposed to interior air, at gypsum between studs

Detail 5.5.14

Exterior and Interior Insulated 6" x 1 5/8" Steel Stud (16" o.c.) Wall Assembly with Thermally Isolated Vertical Brackets and Rail System (24" o.c.) Supporting Metal Cladding and Owens Corning R-22.5 Batt in Stud Cavity – Concrete Parapet and Roof Intersection

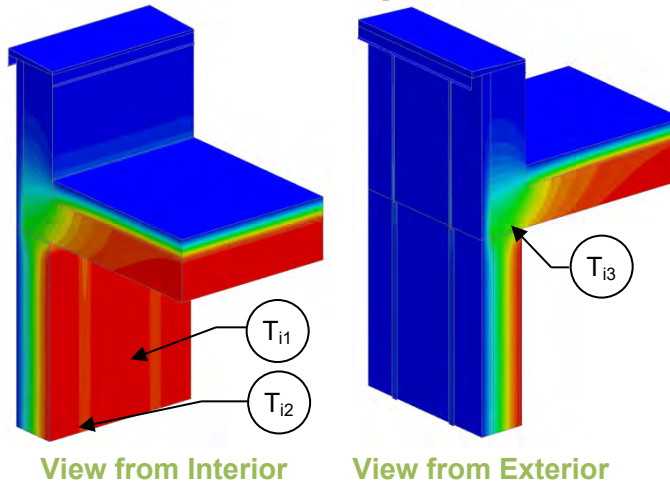

Thermal Performance Indicators

Assembly 1D (Nominal) R-Value	R_{1D}	R-24.9 (4.38 RSI) + exterior insulation
Transmittance / Resistance without Anomaly	U_r, R_r, U_w, R_w	"clear field" U- and R-values for: r = roof w = wall
Transmittance / Resistance	U, R	U- and R-values for overall assembly
Surface Temperature Index ¹	T_i	0 = exterior temperature 1 = interior temperature
Linear Transmittance	ψ	Incremental increase in transmittance per length of parapet

¹Assumptions and limitations for surface temperatures identified in ASHRAE 1365-RP

Nominal (1D) vs. Assembly Performance Indicators

Base Assembly – Wall

Exterior Insulation 1D R-Value (RSI)	R_{1Dw} ft ² ·hr·°F / Btu (m ² K / W)	R_w ft ² ·hr·°F / Btu (m ² K / W)	U_w Btu/ft ² ·hr ·°F (W/m ² K)
R-8.4 (1.48)	R-33.3 (5.86)	R-19.0 (3.34)	0.053 (0.30)
R-21.0 (3.70)	R-45.9 (8.08)	R-26.4 (4.64)	0.038 (0.22)

Base Assembly - Roof

Roof Insulation 1DR-Value (RSI)	R_r ft ² hr °F / Btu (m ² K / W)	U_r Btu/ft ² ·hr ·°F (W/m ² K)
R-20 (3.52)	R-21.9 (3.86)	0.046 (0.26)

Parapet Linear Transmittance

Exterior Insulation 1D R-Value (RSI)	R ft ² ·hr·°F / Btu (m ² K / W)	U Btu/ft ² ·hr ·°F (W/m ² K)	ψ Btu/ft hr °F (W/m K)
R-8.4 (1.48)	R-9.0 (1.58)	0.111 (0.63)	0.388 (0.671)
R-21.0 (3.70)	R-9.7 (1.72)	0.103 (0.58)	0.379 (0.656)

Temperature Indices

	R8.4	R21	
T_{i1}	0.33	0.52	Min T on sheathing at roof slab, away from roof slab, between studs at clip
T_{i2}	0.60	0.72	Max T on sheathing away from roof slab, at studs
T_{i3}	0.67	0.69	Min T on roof slab exposed to interior air, at gypsum between studs

Detail 5.5.15

Exterior and Interior Insulated 6" x 1 5/8" Steel Stud (16" o.c.) Wall Assembly with Thermally Isolated Vertical Brackets and Rail System (24" o.c.) Supporting Metal Cladding and Owens Corning R-24 Batt in Stud Cavity – Concrete Parapet and Roof Intersection

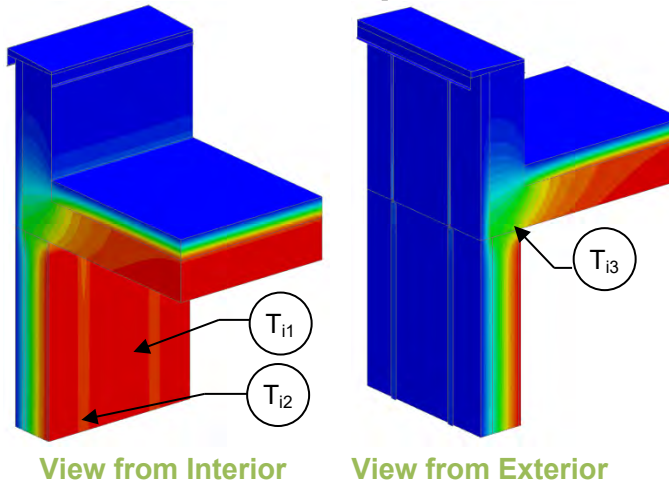

Thermal Performance Indicators

Assembly 1D (Nominal) R-Value	R_{1D}	R-26.4 (4.65 RSI) + exterior insulation
Transmittance / Resistance without Anomaly	U_r, R_r, U_w, R_w	"clear field" U- and R-values for: r = roof w = wall
Transmittance / Resistance	U, R	U- and R-values for overall assembly
Surface Temperature Index ¹	T_i	0 = exterior temperature 1 = interior temperature
Linear Transmittance	ψ	Incremental increase in transmittance per length of parapet

¹Assumptions and limitations for surface temperatures identified in ASHRAE 1365-RP

Nominal (1D) vs. Assembly Performance Indicators Base Assembly – Wall

Exterior Insulation 1D R-Value (RSI)	R_{1Dw} ft ² ·hr·°F / Btu (m ² K / W)	R_w ft ² ·hr·°F / Btu (m ² K / W)	U_w Btu/ft ² ·hr ·°F (W/m ² K)
R-8.4 (1.48)	R-34.8 (6.13)	R-19.3 (3.40)	0.052 (0.29)
R-21.0 (3.70)	R-47.4 (8.34)	R-26.7 (4.71)	0.037 (0.21)

Base Assembly - Roof

Roof Insulation 1DR-Value (RSI)	R_r ft ² hr °F / Btu (m ² K / W)	U_r Btu/ft ² ·hr ·°F (W/m ² K)
R-20 (3.52)	R-21.9 (3.86)	0.046 (0.26)

Parapet Linear Transmittance

Exterior Insulation 1D R-Value (RSI)	R ft ² ·hr·°F / Btu (m ² K / W)	U Btu/ft ² ·hr ·°F (W/m ² K)	ψ Btu/ft hr °F (W/m K)
R-8.4 (1.48)	R-9.0 (1.59)	0.111 (0.63)	0.388 (0.672)
R-21.0 (3.70)	R-9.8 (1.72)	0.102 (0.58)	0.379 (0.657)

Temperature Indices

	R8.4	R21	
T_{i1}	0.32	0.50	Min T on sheathing at roof slab, away from roof slab, between studs at clip
T_{i2}	0.59	0.71	Max T on sheathing away from roof slab, at studs
T_{i3}	0.67	0.69	Min T on roof slab exposed to interior air, at gypsum between studs

Detail 5.5.16

Owens Corning Exterior Insulated 6" x 1 5/8" Steel Stud (16" o.c.) Wall Assembly with Thermally Isolated Vertical Brackets and Rail System (24" o.c.) Supporting Metal Cladding – Concrete Roof Deck at Isokorb AXTI Thermal Broken Concrete Parapet

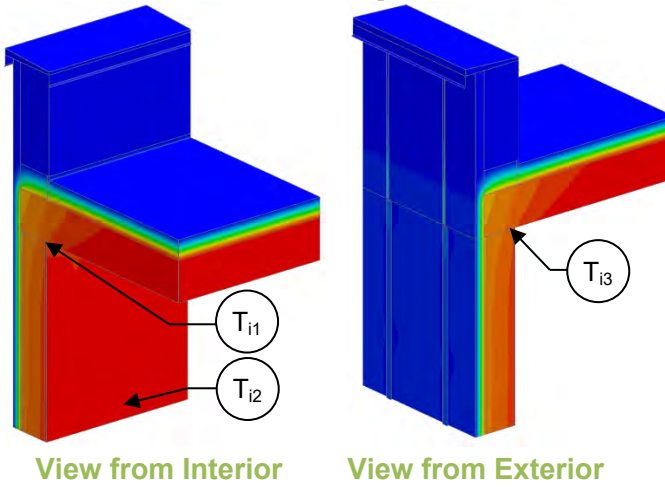

Thermal Performance Indicators

Assembly 1D (Nominal) R-Value	R_{1D}	R-3.3 (0.58 RSI) + exterior insulation
Transmittance / Resistance without Anomaly	U_r, R_r, U_w, R_w	"clear field" U- and R-values for: r = roof w = wall
Transmittance / Resistance	U, R	U- and R-values for overall assembly
Surface Temperature Index ¹	T_i	0 = exterior temperature 1 = interior temperature
Linear Transmittance	ψ	Incremental increase in transmittance per length of parapet

¹Assumptions and limitations for surface temperatures identified in ASHRAE 1365-RP

Nominal (1D) vs. Assembly Performance Indicators Base Assembly – Wall

Exterior Insulation 1D R-Value (RSI)	R_{1Dw} ft ² ·hr·°F / Btu (m ² K / W)	R_w ft ² ·hr·°F / Btu (m ² K / W)	U_w Btu/ft ² ·hr ·°F (W/m ² K)
R-8.4 (1.48)	R-11.7 (2.06)	R-10.0 (1.77)	0.100 (0.57)
R-21.0 (3.70)	R-24.3 (4.28)	R-17.6 (3.10)	0.057 (0.32)

Base Assembly - Roof

Roof Insulation 1DR-Value (RSI)	R_r ft ² hr °F / Btu (m ² K / W)	U_r Btu/ft ² ·hr ·°F (W/m ² K)
R-20 (3.52)	R-21.9 (3.86)	0.046 (0.26)

Parapet Linear Transmittance

Exterior Insulation 1D R-Value (RSI)	R ft ² ·hr·°F / Btu (m ² K / W)	U Btu/ft ² ·hr ·°F (W/m ² K)	ψ Btu/ft hr °F (W/m K)
R-8.4 (1.48)	R-10.6 (1.87)	0.094 (0.53)	0.130 (0.225)
R-21.0 (3.70)	R-14.4 (2.54)	0.069 (0.39)	0.112 (0.194)

Temperature Indices

	R8.4	R21	
T_{i1}	0.71	0.76	Min T on sheathing at roof slab, at clip
T_{i2}	0.81	0.90	Max T on sheathing away from roof slab, between studs
T_{i3}	0.86	0.89	Min T on roof slab exposed to interior air, at gypsum between studs

Detail 5.5.17

Exterior and Interior Insulated 6" x 1 5/8" Steel Stud (16" o.c.) Wall Assembly with Thermally Isolated Vertical Brackets and Rail System (24" o.c.) Supporting Metal Cladding and Owens Corning R-20 Batt in Stud Cavity – Concrete Roof Deck at Isokorb AXTI Thermal Broken Concrete Parapet

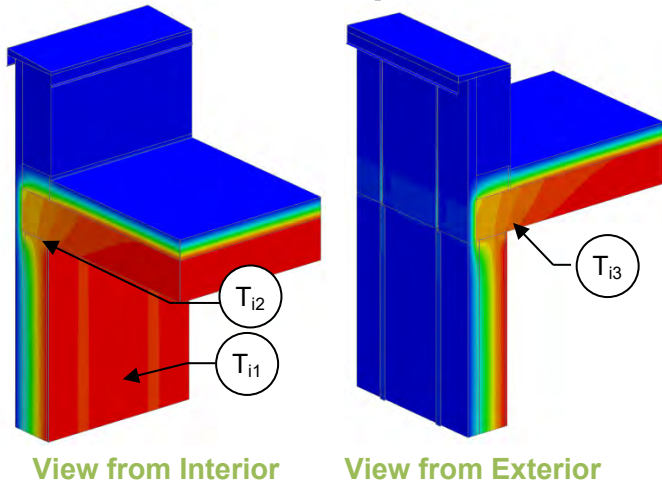

Thermal Performance Indicators

Assembly 1D (Nominal) R-Value	R_{1D}	R-22.4 (3.94 RSI) + exterior insulation
Transmittance / Resistance without Anomaly	U_r, R_r, U_w, R_w	"clear field" U- and R-values for: r = roof w = wall
Transmittance / Resistance	U, R	U- and R-values for overall assembly
Surface Temperature Index ¹	T_i	0 = exterior temperature 1 = interior temperature
Linear Transmittance	ψ	Incremental increase in transmittance per length of parapet

¹Assumptions and limitations for surface temperatures identified in ASHRAE 1365-RP

Nominal (1D) vs. Assembly Performance Indicators

Base Assembly – Wall

Exterior Insulation 1D R-Value (RSI)	R_{1Dw} ft ² ·hr·°F / Btu (m ² K / W)	R_w ft ² ·hr·°F / Btu (m ² K / W)	U_w Btu/ft ² ·hr ·°F (W/m ² K)
R-8.4 (1.48)	R-30.8 (5.42)	R-18.3 (3.23)	0.055 (0.31)
R-21.0 (3.70)	R-43.4 (7.64)	R-25.8 (4.54)	0.039 (0.22)

Base Assembly - Roof

Roof Insulation 1DR-Value (RSI)	R_r ft ² hr °F / Btu (m ² K / W)	U_r Btu/ft ² ·hr ·°F (W/m ² K)
R-20 (3.52)	R-21.9 (3.86)	0.046 (0.26)

Parapet Linear Transmittance

Exterior Insulation 1D R-Value (RSI)	R ft ² ·hr·°F / Btu (m ² K / W)	U Btu/ft ² ·hr ·°F (W/m ² K)	ψ Btu/ft hr °F (W/m K)
R-8.4 (1.48)	R-13.8 (2.43)	0.073 (0.41)	0.139 (0.241)
R-21.0 (3.70)	R-16.6 (2.92)	0.060 (0.34)	0.113 (0.196)

Temperature Indices

	R8.4	R21	
T_{i1}	0.35	0.53	Min T on sheathing away from roof slab, between studs at clip
T_{i2}	0.72	0.78	Max T on sheathing at roof slab, between studs
T_{i3}	0.84	0.87	Min T on roof slab exposed to interior air, at gypsum between studs

Detail 5.5.18

Exterior and Interior Insulated 6" x 1 5/8" Steel Stud (16" o.c.) Wall Assembly with Thermally Isolated Vertical Brackets and Rail System (24" o.c.) Supporting Metal Cladding and Owens Corning R-22.5 Batt in Stud Cavity – Concrete Roof Deck at Isokorb AXTI Thermal Broken Concrete Parapet

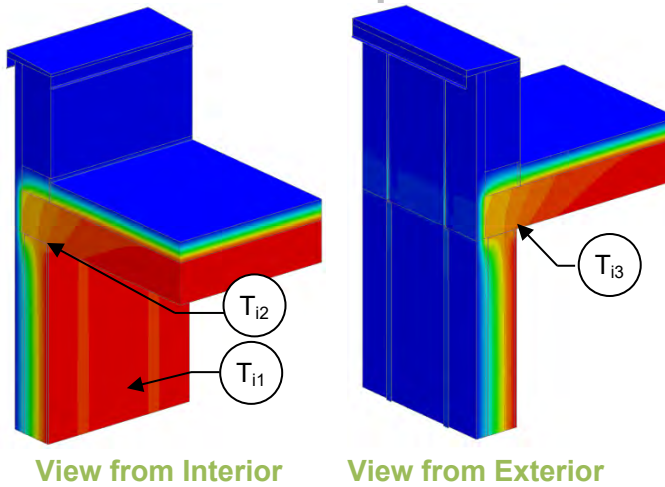

Thermal Performance Indicators

Assembly 1D (Nominal) R-Value	R_{1D}	R-24.9 (4.38 RSI) + exterior insulation
Transmittance / Resistance without Anomaly	U_r, R_r, U_w, R_w	"clear field" U- and R-values for: r = roof w = wall
Transmittance / Resistance	U, R	U- and R-values for overall assembly
Surface Temperature Index ¹	T_i	0 = exterior temperature 1 = interior temperature
Linear Transmittance	ψ	Incremental increase in transmittance per length of parapet

¹Assumptions and limitations for surface temperatures identified in ASHRAE 1365-RP

Nominal (1D) vs. Assembly Performance Indicators

Base Assembly – Wall

Exterior Insulation 1D R-Value (RSI)	R_{1Dw} ft ² ·hr·°F / Btu (m ² K / W)	R_w ft ² ·hr·°F / Btu (m ² K / W)	U_w Btu/ft ² ·hr ·°F (W/m ² K)
R-8.4 (1.48)	R-33.3 (5.86)	R-19.0 (3.34)	0.053 (0.30)
R-21.0 (3.70)	R-45.9 (8.08)	R-26.4 (4.64)	0.038 (0.22)

Base Assembly - Roof

Roof Insulation 1DR-Value (RSI)	R_r ft ² hr °F / Btu (m ² K / W)	U_r Btu/ft ² ·hr ·°F (W/m ² K)
R-20 (3.52)	R-21.9 (3.86)	0.046 (0.26)

Parapet Linear Transmittance

Exterior Insulation 1D R-Value (RSI)	R ft ² ·hr·°F / Btu (m ² K / W)	U Btu/ft ² ·hr ·°F (W/m ² K)	ψ Btu/ft hr °F (W/m K)
R-8.4 (1.48)	R-13.9 (2.46)	0.072 (0.41)	0.140 (0.242)
R-21.0 (3.70)	R-16.7 (2.94)	0.060 (0.34)	0.113 (0.196)

Temperature Indices

	R8.4	R21	
T_{i1}	0.33	0.51	Min T on sheathing away from roof slab, between studs at clip
T_{i2}	0.72	0.78	Max T on sheathing at roof slab, between studs
T_{i3}	0.84	0.87	Min T on roof slab exposed to interior air, at gypsum between studs

Detail 5.5.19

Exterior and Interior Insulated 6" x 1 5/8" Steel Stud (16" o.c.) Wall Assembly with Thermally Isolated Vertical Brackets and Rail System (24" o.c.) Supporting Metal Cladding and Owens Corning R-24 Batt in Stud Cavity – Concrete Roof Deck at Isokorb AXTI Thermal Broken Concrete Parapet

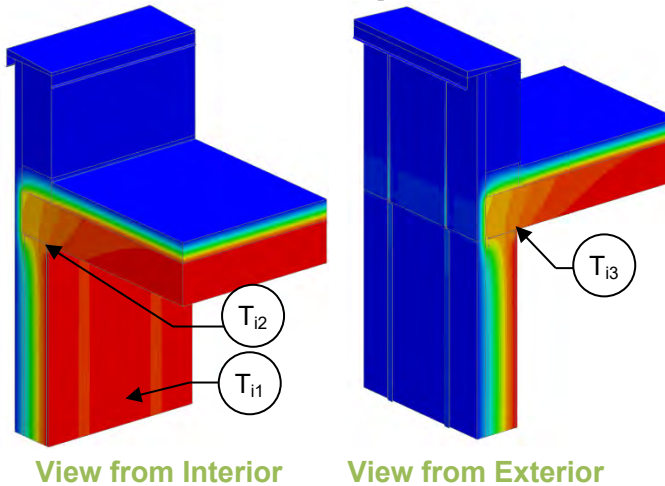

Thermal Performance Indicators

Assembly 1D (Nominal) R-Value	R_{1D}	R-26.4 (4.65 RSI) + exterior insulation
Transmittance / Resistance without Anomaly	U_r, R_r, U_w, R_w	“clear field” U- and R-values for: r = roof w = wall
Transmittance / Resistance	U, R	U- and R-values for overall assembly
Surface Temperature Index ¹	T_i	0 = exterior temperature 1 = interior temperature
Linear Transmittance	ψ	Incremental increase in transmittance per length of parapet

¹Assumptions and limitations for surface temperatures identified in ASHRAE 1365-RP

Nominal (1D) vs. Assembly Performance Indicators

Base Assembly – Wall

Exterior Insulation 1D R-Value (RSI)	R_{1Dw} ft ² ·hr·°F / Btu (m ² K / W)	R_w ft ² ·hr·°F / Btu (m ² K / W)	U_w Btu/ft ² ·hr ·°F (W/m ² K)
R-8.4 (1.48)	R-34.8 (6.13)	R-19.3 (3.40)	0.052 (0.29)
R-21.0 (3.70)	R-47.4 (8.34)	R-26.7 (4.71)	0.037 (0.21)

Base Assembly - Roof

Roof Insulation 1DR-Value (RSI)	R_r ft ² hr °F / Btu (m ² K / W)	U_r Btu/ft ² ·hr ·°F (W/m ² K)
R-20 (3.52)	R-21.9 (3.86)	0.046 (0.26)

Parapet Linear Transmittance

Exterior Insulation 1D R-Value (RSI)	R ft ² ·hr·°F / Btu (m ² K / W)	U Btu/ft ² ·hr ·°F (W/m ² K)	ψ Btu/ft hr °F (W/m K)
R-8.4 (1.48)	R-14.0 (2.47)	0.071 (0.41)	0.141 (0.244)
R-21.0 (3.70)	R-16.7 (2.94)	0.060 (0.34)	0.115 (0.199)

Temperature Indices

	R8.4	R21	
T_{i1}	0.32	0.51	Min T on sheathing away from roof slab, between studs at clip
T_{i2}	0.72	0.78	Max T on sheathing at roof slab, between studs
T_{i3}	0.84	0.87	Min T on roof slab exposed to interior air, at gypsum between studs

Detail 5.5.20

Exterior Insulated 6" x 1 5/8" Steel Stud (16" o.c.) Wall Assembly with Thermally Isolated Vertical Brackets and Rail System Supporting Metal Cladding – Concrete Roof Deck at Isokorb AXT Thermally Broken Concrete Parapet

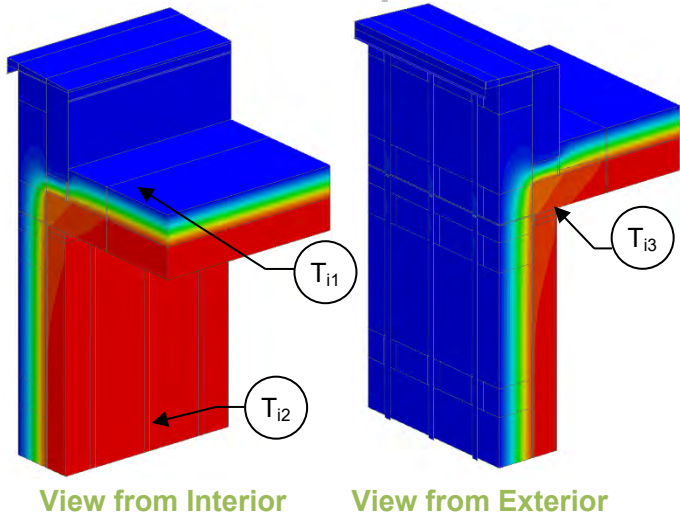

Thermal Performance Indicators

Assembly 1D (Nominal) R-Value	R_{1D}	R-3.2 (0.56 RSI) + exterior insulation
Transmittance / Resistance without Anomaly	U_r, R_r, U_w, R_w	"clear field" U- and R-values for: r = roof w = wall
Transmittance / Resistance	U, R	U- and R-values for overall assembly
Surface Temperature Index ¹	T_i	0 = exterior temperature 1 = interior temperature
Linear Transmittance	ψ	Incremental increase in transmittance per linear length of parapet

¹Assumptions and limitations for surface temperatures identified in ASHRAE 1365-RP

Scenario

Scenario	
A	Sloped Roof
B	Concrete Topping
C	Insulation Between AXT Module at the Same Height as Roof Insulation

Nominal (1D) vs. Assembly Performance Indicators

Base Assembly – Wall

Exterior Insulation 1D R-Value (RSI)	R_{1Dw} ft ² ·hr·°F / Btu (m ² K / W)	R_w ft ² ·hr·°F / Btu (m ² K / W)	U_w Btu/ft ² ·hr·°F (W/m ² K)
R-42.0 (7.40)	R-45.2 (7.96)	R-40.0 (7.04)	0.025 (0.14)

Base Assembly - Roof

Roof Insulation 1D R-Value (RSI)	R_r ft ² hr °F / Btu (m ² K / W)	U_r Btu/ft ² ·hr·°F (W/m ² K)
R-40 (7.01)	R-41.9 (7.39)	0.024 (0.14)

Parapet Linear Transmittance

Scenario	Exterior Insulation 1D R-Value (RSI)	R ft ² ·hr·°F / Btu (m ² K / W)	U Btu/ft ² ·hr·°F (W/m ² K)	ψ Btu/ft hr °F (W/m K)
A	R-42.0 (7.40)	R-23.1 (4.07)	0.043 (0.25)	0.099 (0.171)
B	R-42.0 (7.40)	R-25.4 (4.48)	0.039 (0.22)	0.078 (0.136)
C	R-42.0 (7.40)	R-27.4 (4.83)	0.036 (0.21)	0.063 (0.110)

Temperature Indices

	A	B	C	
T_{i1}	0.88	0.91	0.92	Min T on sheathing at roof slab, aligned with Isokorb AXT Thermal Break
T_{i2}	0.95	0.95	0.95	Max T on sheathing away from roof slab, beside studs
T_{i3}	0.91	0.94	0.94	Min T on roof slab exposed to interior air, at gypsum, aligned with Isokorb AXT Thermal Break

Detail 5.5.21

Exterior and Interior Insulated 6" x 1 5/8" Steel Stud (16" o.c.) Wall Assembly with Thermally Isolated Vertical Brackets and Rail System Supporting Metal Cladding and R-19 Batt in Stud Cavity – Concrete Roof Deck at Isokorb AXT Thermally Broken Concrete Parapet

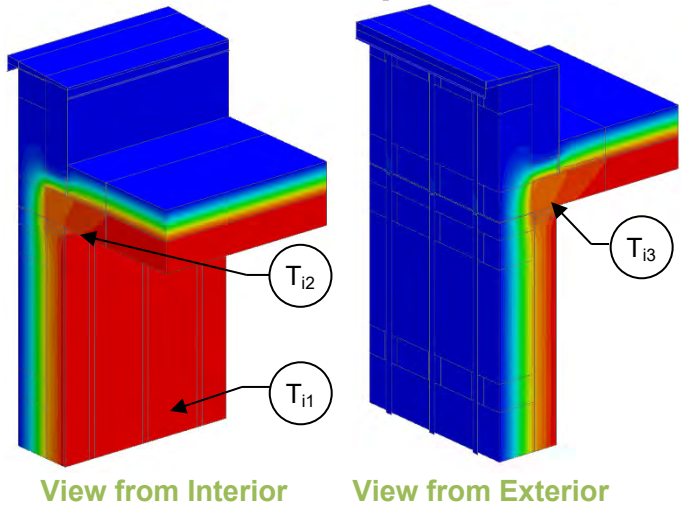

Thermal Performance Indicators

Assembly 1D (Nominal) R-Value	R _{1D}	R-21.3 (3.75 RSI) + exterior insulation
Transmittance / Resistance without Anomaly	U _r , R _r , U _w , R _w	"clear field" U- and R-values for: r = roof w = wall
Transmittance / Resistance	U, R	U- and R-values for overall assembly
Surface Temperature Index ¹	T _i	0 = exterior temperature 1 = interior temperature
Linear Transmittance	ψ	Incremental increase in transmittance per linear length of parapet

¹Assumptions and limitations for surface temperatures identified in ASHRAE 1365-RP

Scenario

Scenario	
A	Sloped Roof
B	Concrete Topping
C	Insulation Between AXT Module at the Same Height as Roof Insulation

Nominal (1D) vs. Assembly Performance Indicators

Base Assembly – Wall

Exterior Insulation 1D R-Value (RSI)	R _{1Dw} ft ² ·hr·°F / Btu (m ² K / W)	R _w ft ² ·hr·°F / Btu (m ² K / W)	U _w Btu/ft ² ·hr·°F (W/m ² K)
R-42.0 (7.40)	R-63.3 (11.15)	R-48.3 (8.51)	0.021 (0.12)

Base Assembly - Roof

Roof Insulation 1D R-Value (RSI)	R _r ft ² hr °F / Btu (m ² K / W)	U _r Btu/ft ² ·hr·°F (W/m ² K)
R-40 (7.01)	R-41.9 (7.39)	0.024 (0.14)

Parapet Linear Transmittance

Scenario	Exterior Insulation 1D R-Value (RSI)	R ft ² ·hr·°F / Btu (m ² K / W)	U Btu/ft ² ·hr·°F (W/m ² K)	ψ Btu/ft hr °F (W/m K)
A	R-42.0 (7.40)	R-24.1 (4.25)	0.041 (0.24)	0.099 (0.171)
B	R-42.0 (7.40)	R-26.6 (4.68)	0.038 (0.21)	0.079 (0.137)
C	R-42.0 (7.40)	R-28.7 (5.05)	0.035 (0.20)	0.064 (0.111)

Temperature Indices

	A	B	C	
T ₁₁	0.77	0.77	0.77	Min T on sheathing away from roof slab, between studs
T ₁₂	0.88	0.89	0.90	Max T on sheathing at roof slab, at studs, not aligned with Isokorb AXT Thermal Break
T ₁₃	0.90	0.92	0.93	Min T on roof slab exposed to interior air, at gypsum, aligned with Isokorb AXT Thermal Break

Detail 5.5.22

Exterior Insulated 6" x 1 5/8" Steel Stud (16" o.c.) Wall Assembly with Thermally Isolated Vertical Brackets and Rail System (24" o.c.) Supporting Metal Cladding – Concrete Parapet and Roof Intersection

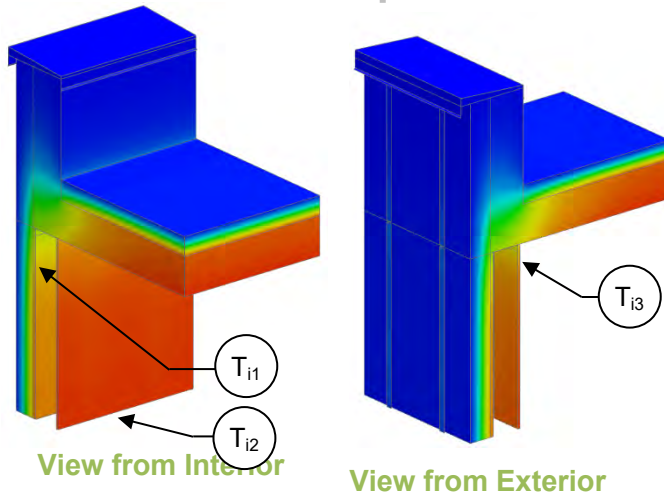

Thermal Performance Indicators

Assembly 1D (Nominal) R-Value	R_{1D}	R-3.3 (0.58 RSI) + exterior insulation
Transmittance / Resistance without Anomaly	U_r, R_r, U_w, R_w	"clear field" U- and R-values for: r = roof w = wall
Transmittance / Resistance	U, R	U- and R-values for overall assembly
Surface Temperature Index ¹	T_i	0 = exterior temperature 1 = interior temperature
Linear Transmittance	ψ	Incremental increase in transmittance per length of parapet

¹Assumptions and limitations for surface temperatures identified in ASHRAE 1365-RP

Nominal (1D) vs. Assembly Performance Indicators

Base Assembly – Wall

Exterior Insulation 1D R-Value (RSI)	R_{1Dw} ft ² ·hr·°F / Btu (m ² K / W)	R_w ft ² ·hr·°F / Btu (m ² K / W)	U_w Btu/ft ² ·hr·°F (W/m ² K)
R-16.8 (2.96)	R-20.1 (3.54)	R-14.7 (2.59)	0.068 (0.39)
R-21.0 (3.70)	R-24.3 (4.28)	R-17.0 (3.00)	0.059 (0.33)
R-25.2 (4.44)	R-28.5 (5.02)	R-19.1 (3.37)	0.052 (0.30)
R-29.4 (5.18)	R-32.7 (5.76)	R-21.0 (3.71)	0.048 (0.27)

Base Assembly - Roof

Roof Insulation 1DR-Value (RSI)	R_r ft ² hr °F / Btu (m ² K / W)	U_r Btu/ft ² ·hr ·°F (W/m ² K)
R-20.0 (3.52)	R-21.9 (3.86)	0.046 (0.26)
R-40.0 (7.04)	R-41.9 (7.39)	0.024 (0.14)

Parapet Linear Transmittance

Exterior Insulation 1D R-Value (RSI)	R-20 Roof Insulation			R-40 Roof Insulation		
	R ft ² ·hr·°F / Btu (m ² K / W)	U Btu/ft ² ·hr ·°F (W/m ² K)	ψ Btu/ft hr °F (W/m K)	R ft ² ·hr·°F / Btu (m ² K / W)	U Btu/ft ² ·hr ·°F (W/m ² K)	ψ Btu/ft hr °F (W/m K)
R-16.8 (2.96)	R-8.2 (1.45)	0.122 (0.69)	0.403 (0.698)	R-9.6 (1.70)	0.104 (0.59)	0.359 (0.621)
R-21.0 (3.70)	R-8.5 (1.51)	0.117 (0.66)	0.404 (0.699)	R-10.1 (1.78)	0.099 (0.56)	0.357 (0.619)
R-25.2 (4.44)	R-8.8 (1.55)	0.114 (0.65)	0.404 (0.699)	R-10.5 (1.84)	0.095 (0.54)	0.357 (0.617)
R-29.4 (5.18)	R-9.0 (1.58)	0.111 (0.63)	0.404 (0.700)	R-10.8 (1.89)	0.093 (0.53)	0.356 (0.616)

Temperature Indices

	R-20 Roof Insulation				R-40 Roof Insulation				
	R16.8	R21.0	R25.2	R29.4	R16.8	R21.0	R25.2	R29.4	
T_{11}	0.60	0.61	0.61	0.62	0.63	0.64	0.65	0.65	Min T on sheathing away from roof slab, at clip
T_{12}	0.87	0.89	0.90	0.91	0.87	0.89	0.91	0.91	Max T on sheathing away from roof slab, between studs
T_{13}	0.79	0.79	0.79	0.80	0.82	0.82	0.82	0.83	Min T on roof slab exposed to interior air, at gypsum between studs

Detail 5.5.23

Exterior and Interior Insulated 6" x 1 5/8" Steel Stud (16" o.c.) Wall Assembly with Thermally Isolated Vertical Brackets and Rail System (24" o.c.) Supporting Metal Cladding and R-20 Batt in Stud Cavity – Concrete Parapet and Roof Intersection

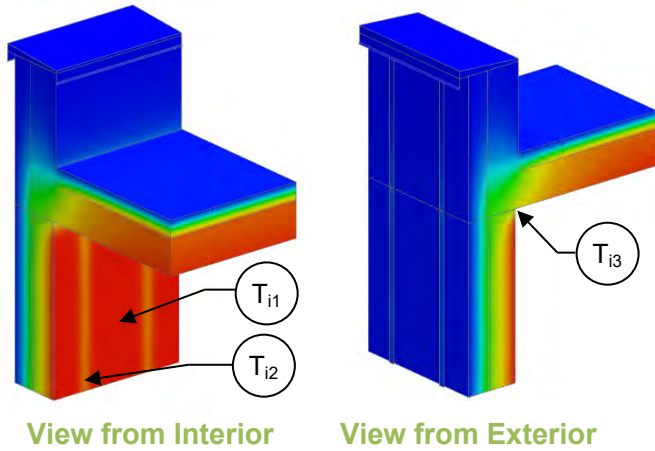

Thermal Performance Indicators

1.00	Assembly 1D (Nominal) R-Value	R_{1D}	R-22.4 (3.94 RSI) + exterior insulation
0.90	Transmittance / Resistance without Anomaly	U_r, R_r, U_w, R_w	"clear field" U- and R-values for: r = roof w = wall
0.80	Transmittance / Resistance	U, R	U- and R-values for overall assembly
0.70	Surface Temperature Index ¹	T_i	0 = exterior temperature 1 = interior temperature
0.60	Linear Transmittance	ψ	Incremental increase in transmittance per length of parapet
0.50			
0.40			
0.30			
0.20			
0.10			
0.00			

¹Assumptions and limitations for surface temperatures identified in ASHRAE 1365-RP

Nominal (1D) vs. Assembly Performance Indicators

Base Assembly – Wall

Exterior Insulation 1D R-Value (RSI)	R_{1Dw} ft ² ·hr·°F / Btu (m ² K / W)	R_w ft ² ·hr·°F / Btu (m ² K / W)	U_w Btu/ft ² ·hr·°F (W/m ² K)
R-16.8 (2.96)	R-39.2 (6.90)	R-22.9 (4.03)	0.044 (0.25)
R-21.0 (3.70)	R-43.4 (7.64)	R-25.2 (4.44)	0.040 (0.23)
R-25.2 (4.44)	R-47.6 (8.38)	R-27.3 (4.81)	0.037 (0.21)
R-29.4 (5.18)	R-51.8 (9.12)	R-29.2 (5.15)	0.034 (0.19)

Base Assembly - Roof

Roof Insulation 1DR-Value (RSI)	R_r ft ² hr °F / Btu (m ² K / W)	U_r Btu/ft ² ·hr·°F (W/m ² K)
R-20.0 (3.52)	R-21.9 (3.86)	0.046 (0.26)
R-40.0 (7.04)	R-41.9 (7.39)	0.024 (0.14)

Parapet Linear Transmittance

Exterior Insulation 1D R-Value (RSI)	R-20 Roof Insulation			R-40 Roof Insulation		
	R ft ² ·hr·°F / Btu (m ² K / W)	U Btu/ft ² ·hr·°F (W/m ² K)	ψ Btu/ft hr °F (W/m K)	R ft ² ·hr·°F / Btu (m ² K / W)	U Btu/ft ² ·hr·°F (W/m ² K)	ψ Btu/ft hr °F (W/m K)
R-16.8 (2.96)	R-9.5 (1.66)	0.106 (0.60)	0.381 (0.660)	R-11.2 (1.97)	0.089 (0.51)	0.345 (0.597)
R-21.0 (3.70)	R-9.7 (1.70)	0.103 (0.59)	0.379 (0.656)	R-11.5 (2.03)	0.087 (0.49)	0.342 (0.591)
R-25.2 (4.44)	R-9.8 (1.73)	0.102 (0.58)	0.378 (0.654)	R-11.8 (2.08)	0.085 (0.48)	0.339 (0.587)
R-29.4 (5.18)	R-10.0 (1.76)	0.100 (0.57)	0.377 (0.653)	R-12.0 (2.11)	0.083 (0.47)	0.338 (0.585)

Temperature Indices

	R-20 Roof Insulation				R-40 Roof Insulation				
	R16.8	R21.0	R25.2	R29.4	R16.8	R21.0	R25.2	R29.4	
T_{i1}	0.46	0.47	0.48	0.49	0.49	0.50	0.51	0.52	Min T on sheathing away from roof slab, at clip
T_{i2}	0.69	0.73	0.75	0.77	0.69	0.73	0.75	0.77	Max T on sheathing away from roof slab, at studs
T_{i3}	0.75	0.75	0.76	0.76	0.78	0.79	0.79	0.79	Min T on roof slab exposed to interior air, at gypsum between studs

Detail 5.5.24

Exterior Insulated 6" x 1 5/8" Steel Stud (16" o.c.) Wall Assembly with Thermally Isolated Vertical Brackets and Rail System (24" o.c.) Supporting Metal Cladding – Concrete Roof Deck at Isokorb AXTI Thermal Broken Concrete Parapet

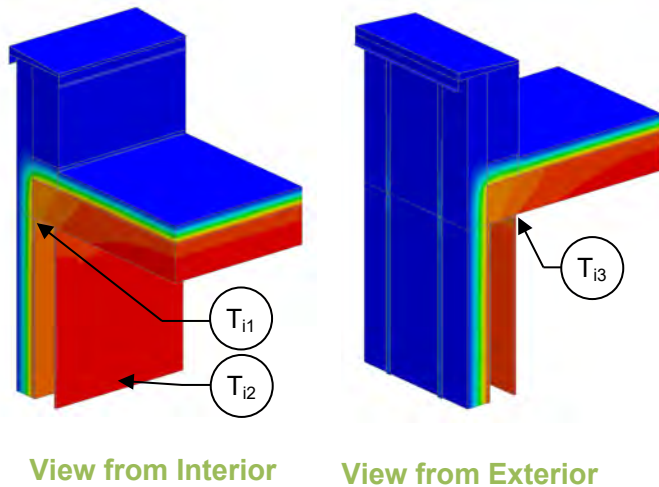

Thermal Performance Indicators

Assembly 1D (Nominal) R-Value	R _{1D}	R-3.3 (0.58 RSI) + exterior insulation
Transmittance / Resistance without Anomaly	U _r , R _r , U _w , R _w	"clear field" U- and R-values for: r = roof w = wall
Transmittance / Resistance	U, R	U- and R-values for overall assembly
Surface Temperature Index ¹	T _i	0 = exterior temperature 1 = interior temperature
Linear Transmittance	ψ	Incremental increase in transmittance per length of parapet

¹Assumptions and limitations for surface temperatures identified in ASHRAE 1365-RP

Nominal (1D) vs. Assembly Performance Indicators

Base Assembly – Wall

Exterior Insulation 1D R-Value (RSI)	R _{1Dw} ft ² ·hr·°F / Btu (m ² K / W)	R _w ft ² ·hr·°F / Btu (m ² K / W)	U _w Btu/ft ² ·hr·°F (W/m ² K)
R-16.8 (2.96)	R-20.1 (3.54)	R-14.7 (2.59)	0.068 (0.39)
R-21.0 (3.70)	R-24.3 (4.28)	R-17.0 (3.00)	0.059 (0.33)
R-25.2 (4.44)	R-28.5 (5.02)	R-19.1 (3.37)	0.052 (0.30)
R-29.4 (5.18)	R-32.7 (5.76)	R-21.0 (3.71)	0.048 (0.27)

Base Assembly - Roof

Roof Insulation 1DR-Value (RSI)	R _r ft ² hr °F / Btu (m ² K / W)	U _r Btu/ft ² ·hr ·°F (W/m ² K)
R-20.0 (3.52)	R-21.9 (3.86)	0.046 (0.26)
R-40.0 (7.04)	R-41.9 (7.38)	0.024 (0.14)

Parapet Linear Transmittance

Exterior Insulation 1D R-Value (RSI)	R-20 Roof Insulation			R-40 Roof Insulation		
	R ft ² ·hr·°F / Btu (m ² K / W)	U Btu/ft ² ·hr ·°F (W/m ² K)	ψ Btu/ft hr °F (W/m K)	R ft ² ·hr·°F / Btu (m ² K / W)	U Btu/ft ² ·hr ·°F (W/m ² K)	ψ Btu/ft hr °F (W/m K)
R-16.8 (2.96)	R-13.2 (2.33)	0.076 (0.43)	0.116 (0.200)	R-15.2 (2.68)	0.066 (0.37)	0.121 (0.209)
R-21.0 (3.70)	R-14.3 (2.52)	0.070 (0.40)	0.111 (0.191)	R-16.6 (2.93)	0.060 (0.34)	0.116 (0.200)
R-25.2 (4.44)	R-15.1 (2.66)	0.066 (0.38)	0.107 (0.185)	R-17.8 (3.13)	0.056 (0.32)	0.112 (0.194)
R-29.4 (5.18)	R-15.8 (2.78)	0.063 (0.36)	0.105 (0.181)	R-18.7 (3.30)	0.053 (0.30)	0.109 (0.189)

Temperature Indices

	R-20 Roof Insulation				R-40 Roof Insulation				
	R16.8	R21.0	R25.2	R29.4	R16.8	R21.0	R25.2	R29.4	
T _{i1}	0.74	0.75	0.76	0.77	0.74	0.76	0.77	0.77	Min T on sheathing away from roof slab, at clip
T _{i2}	0.88	0.90	0.91	0.92	0.88	0.90	0.91	0.92	Max T on sheathing away from roof slab, between studs
T _{i3}	0.91	0.91	0.92	0.92	0.91	0.92	0.92	0.93	Min T on roof slab exposed to interior air, at gypsum between studs



Detail 5.5.25

Exterior and Interior Insulated 6" x 1 5/8" Steel Stud (16" o.c.) Wall Assembly with Thermally Isolated Vertical Brackets and Rail System (24" o.c.) Supporting Metal Cladding and R-20 Batt in Stud Cavity – Concrete Roof Deck at Isokorb AXTI Thermal Broken Concrete Parapet

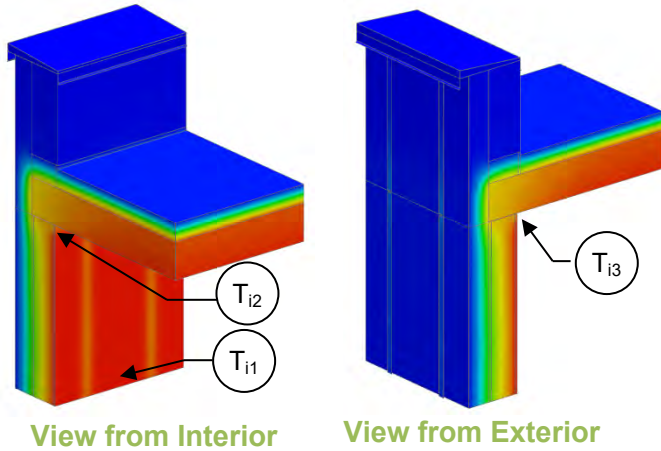

Thermal Performance Indicators

Assembly 1D (Nominal) R-Value	R_{1D}	R-22.4 (3.94 RSI) + exterior insulation
Transmittance / Resistance without Anomaly	U_r, R_r, U_w, R_w	"clear field" U- and R-values for: r = roof w = wall
Transmittance / Resistance	U, R	U- and R-values for overall assembly
Surface Temperature Index ¹	T_i	0 = exterior temperature 1 = interior temperature
Linear Transmittance	ψ	Incremental increase in transmittance per length of parapet

¹Assumptions and limitations for surface temperatures identified in ASHRAE 1365-RP

Nominal (1D) vs. Assembly Performance Indicators

Base Assembly – Wall

Exterior Insulation 1D R-Value (RSI)	R_{1Dw} ft ² ·hr·°F / Btu (m ² K / W)	R_w ft ² ·hr·°F / Btu (m ² K / W)	U_w Btu/ft ² ·hr·°F (W/m ² K)
R-16.8 (2.96)	R-39.2 (6.90)	R-22.9 (4.03)	0.044 (0.25)
R-21.0 (3.70)	R-43.4 (7.64)	R-25.2 (4.44)	0.040 (0.23)
R-25.2 (4.44)	R-47.6 (8.38)	R-27.3 (4.81)	0.037 (0.21)
R-29.4 (5.18)	R-51.8 (9.12)	R-29.2 (5.15)	0.034 (0.19)

Base Assembly - Roof

Roof Insulation 1DR-Value (RSI)	R_r ft ² hr °F / Btu (m ² K / W)	U_r Btu/ft ² ·hr ·°F (W/m ² K)
R-20.0 (3.52)	R-21.9 (3.86)	0.046 (0.26)
R-40.0 (7.04)	R-41.9 (7.38)	0.024 (0.14)

Parapet Linear Transmittance

Exterior Insulation 1D R-Value (RSI)	R-20 Roof Insulation			R-40 Roof Insulation		
	R ft ² ·hr·°F / Btu (m ² K / W)	U Btu/ft ² ·hr ·°F (W/m ² K)	ψ Btu/ft hr °F (W/m K)	R ft ² ·hr·°F / Btu (m ² K / W)	U Btu/ft ² ·hr ·°F (W/m ² K)	ψ Btu/ft hr °F (W/m K)
R-16.8 (2.96)	R-15.5 (2.74)	0.064 (0.37)	0.123 (0.212)	R-18.3 (3.23)	0.055 (0.31)	0.129 (0.223)
R-21.0 (3.70)	R-16.3 (2.88)	0.061 (0.35)	0.116 (0.201)	R-19.4 (3.43)	0.051 (0.29)	0.122 (0.211)
R-25.2 (4.44)	R-17.0 (2.99)	0.059 (0.33)	0.111 (0.193)	R-20.4 (3.59)	0.049 (0.28)	0.117 (0.202)
R-29.4 (5.18)	R-17.5 (3.08)	0.057 (0.32)	0.108 (0.187)	R-21.1 (3.72)	0.047 (0.27)	0.113 (0.196)

Temperature Indices

	R-20 Roof Insulation				R-40 Roof Insulation				
	R16.8	R21.0	R25.2	R29.4	R16.8	R21.0	R25.2	R29.4	
T_{i1}	0.49	0.52	0.55	0.56	0.49	0.52	0.55	0.57	Min T on sheathing away from roof slab, at clip
T_{i2}	0.77	0.79	0.80	0.80	0.78	0.80	0.81	0.82	Max T on sheathing at roof slab, between studs
T_{i3}	0.89	0.89	0.90	0.90	0.90	0.90	0.90	0.91	Min T on roof slab exposed to interior air, at gypsum between studs

Detail 5.6.1

Exterior Insulated 3 5/8" x 1 5/8" Steel Stud (16" o.c.) Drained EIFS Wall Assembly – Corner Intersection

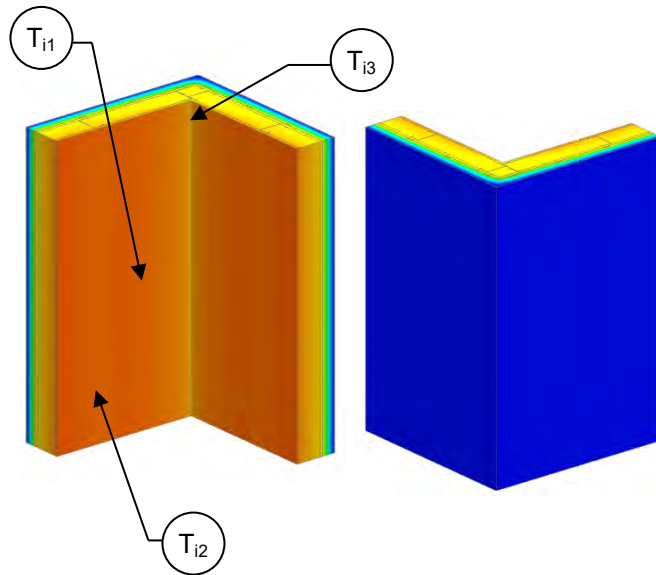

Thermal Performance Indicators

Assembly 1D (Nominal) R-Value	R_{1D}	R-2.7 (0.47 RSI) + exterior insulation
Transmittance / Resistance without Anomaly	U_o, R_o	“clear wall” U- and R-value, without corner
Transmittance / Resistance	U, R	U and R-values for the overall assembly
Surface Temperature Index ¹	T_i	0 = exterior temperature 1 = interior temperature
Linear Transmittance	ψ	Incremental increase in transmittance per linear length of corner

¹Assumptions and limitations for surface temperatures identified in ASHRAE 1365-RP

View from Interior

View from Exterior

Nominal (1D) vs. Assembly Performance Indicators

Exterior Insulation 1D R-Value (RSI)	R_{1D} ft ² ·hr·°F / Btu (m ² K / W)	R_o ft ² ·hr·°F / Btu (m ² K / W)	U_o Btu/ft ² ·hr ·°F (W/m ² K)	R ft ² ·hr·°F / Btu (m ² K / W)	U Btu/ft ² ·hr ·°F (W/m ² K)	ψ Btu/ft hr °F (W/m K)
R-7.5 (1.32)	R-10.2 (1.80)	R-10.0 (1.76)	0.100 (0.57)	R-8.7 (1.53)	0.120 (0.65)	0.060 (0.105)
R-11.3 (1.98)	R-13.9 (2.46)	R-13.7 (2.41)	0.073 (0.41)	R-11.7 (2.05)	0.090 (0.49)	0.051 (0.088)
R-15 (2.64)	R-17.7 (3.12)	R-17.4 (3.06)	0.057 (0.33)	R-14.6 (2.57)	0.070 (0.39)	0.044 (0.076)

Temperature Indices

	R7.5	R11.3	R15	
T_{i1}	0.64	0.71	0.76	Min T on sheathing, between studs
T_{i2}	0.81	0.86	0.89	Max T on sheathing, along studs away from corner
T_{i3}	0.83	0.87	0.90	Min T on drywall, at corner

Detail 5.6.2

Exterior and Interior Insulated 3 5/8" x 1 5/8" Steel Stud (16" o.c.) Drained EIFS Wall Assembly with R-12 Batt Insulation in Stud Cavity – Corner Intersection

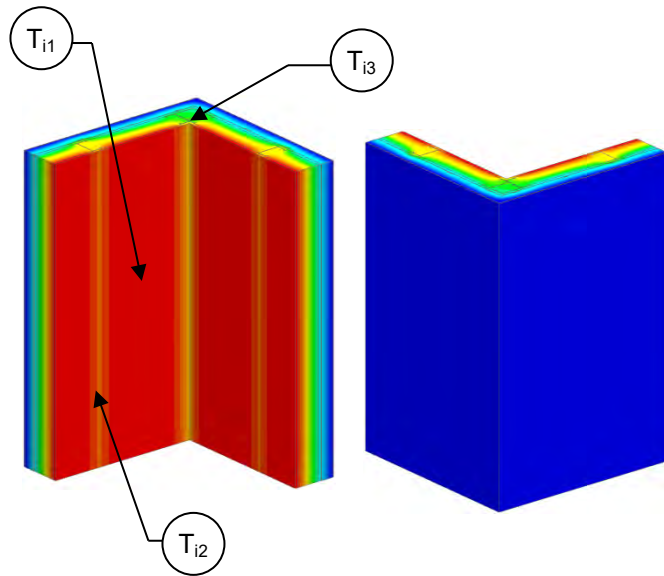

Thermal Performance Indicators

Assembly 1D (Nominal) R-Value	R_{1D}	R-14.2 (2.51 RSI) + exterior insulation
Transmittance / Resistance without Anomaly	U_o, R_o	“clear wall” U- and R-value, without corner
Transmittance / Resistance	U, R	U and R-values for the overall assembly
Surface Temperature Index ¹	T_i	0 = exterior temperature 1 = interior temperature
Linear Transmittance	ψ	Incremental increase in transmittance per linear length of corner

¹Assumptions and limitations for surface temperatures identified in ASHRAE 1365-RP

View from Interior

View from Exterior

Nominal (1D) vs. Assembly Performance Indicators

Exterior Insulation 1D R-Value (RSI)	R_{1D} ft ² ·hr·°F / Btu (m ² K / W)	R_o ft ² ·hr·°F / Btu (m ² K / W)	U_o Btu/ft ² ·hr·°F (W/m ² K)	R ft ² ·hr·°F / Btu (m ² K / W)	U Btu/ft ² ·hr·°F (W/m ² K)	ψ Btu/ft hr °F (W/m K)
R-7.5 (1.32)	R-21.7 (3.83)	R-16.6 (2.93)	0.060 (0.34)	R-14.3 (2.52)	0.07 (0.40)	0.039 (0.067)
R-15 (2.64)	R-29.2 (5.15)	R-24.0 (4.23)	0.042 (0.24)	R-20.2 (3.56)	0.05 (0.28)	0.031 (0.054)

Temperature Indices

	R7.5	R15	
T_{i1}	0.39	0.56	Min T on sheathing, between studs
T_{i2}	0.66	0.77	Max T on sheathing, along studs away from corner
T_{i3}	0.75	0.81	Min T on drywall, at corner

Detail 5.6.3

Exterior Insulated 3 5/8" x 1 5/8" Steel Stud (16" O.C.) Wall Assembly with Horizontal Z-Girts (24" O.C.) Supporting Metal Cladding – Corner Intersection

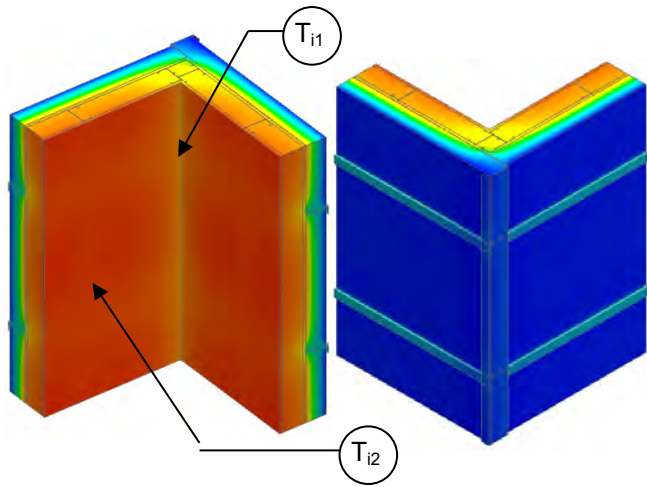

View from Interior

View from Exterior

Thermal Performance Indicators

Assembly 1D (Nominal) R-Value	R_{1D}	R-3.2 (0.56 RSI) + exterior insulation
Transmittance / Resistance without Anomaly	U_o, R_o	"clear wall" U- and R-value, without corner
Transmittance / Resistance	U, R	U and R-values for the overall assembly
Surface Temperature Index ¹	T_i	0 = exterior temperature 1 = interior temperature
Linear Transmittance	ψ	Incremental increase in transmittance per linear length of corner

¹Assumptions and limitations for surface temperatures identified in ASHRAE 1365-RP

Nominal (1D) vs. Assembly Performance Indicators

Exterior Insulation 1D R-Value (RSI)	R_{1D} ft ² ·hr·°F / Btu (m ² K / W)	R_o ft ² ·hr·°F / Btu (m ² K / W)	U_o Btu/ft ² ·hr ·°F (W/m ² K)	R ft ² ·hr·°F / Btu (m ² K / W)	U Btu/ft ² ·hr ·°F (W/m ² K)	ψ Btu/ft hr °F (W/m K)
R-5 (0.88)	R-8.2 (1.44)	R-6.8 (1.21)	0.146 (0.83)	R-5.9 (1.04)	0.169 (0.96)	0.092 (0.160)
R-10 (1.76)	R-13.2 (2.32)	R-9.4 (1.66)	0.106 (0.60)	R-7.7 (1.36)	0.129 (0.73)	0.091 (0.158)
R-15 (2.64)	R-18.2 (3.20)	R-11.3 (1.99)	0.088 (0.50)	R-9.0 (1.59)	0.111 (0.63)	0.089 (0.154)
R-20 (3.52)	R-23.2 (4.08)	R-13.1 (2.31)	0.076 (0.43)	R-10.1 (1.77)	0.099 (0.56)	0.092 (0.160)
R-25 (4.40)	R-28.2 (4.96)	R-14.5 (2.56)	0.069 (0.39)	R-10.9 (1.92)	0.091 (0.52)	0.091 (0.158)

Temperature Indices

	R5	R10	R15	R20	R25	
T_{i1}	0.36	0.42	0.45	0.48	0.50	Min T on sheathing, along studs at girts and corner intersection
T_{i2}	0.76	0.83	0.87	0.89	0.90	Max T on sheathing, at steel studs, between girts, away from corner

Detail 5.6.4

Exterior Insulated 3 5/8" x 1 5/8" Steel Stud (16" O.C.) Wall Assembly with Horizontal Z-Girts (24" O.C.) Supporting Metal Cladding – Corner Intersection with Alternative Framing

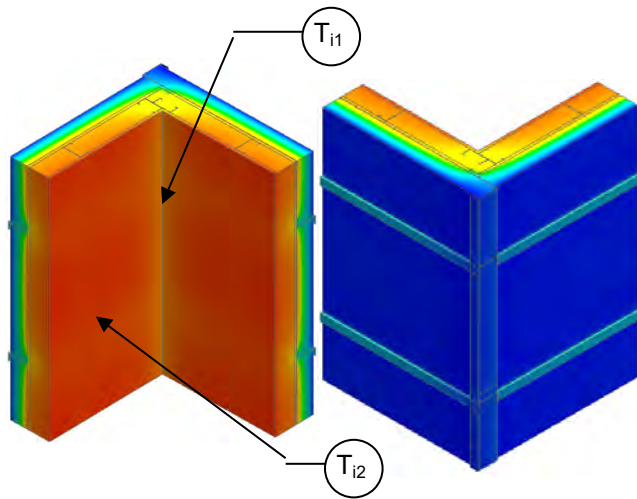

View from Interior

View from Exterior

Thermal Performance Indicators

Assembly 1D (Nominal) R-Value	R_{1D}	R-3.2 (0.56 RSI) + exterior insulation
Transmittance / Resistance without Anomaly	U_o, R_o	“clear wall” U- and R-value, without corner
Transmittance / Resistance	U, R	U and R-values for the overall assembly
Surface Temperature Index ¹	T_i	0 = exterior temperature 1 = interior temperature
Linear Transmittance	ψ	Incremental increase in transmittance per linear length of corner

¹Assumptions and limitations for surface temperatures identified in ASHRAE 1365-RP

Nominal (1D) vs. Assembly Performance Indicators

Exterior Insulation 1D R-Value (RSI)	R_{1D} ft ² ·hr·°F / Btu (m ² K / W)	R_o ft ² ·hr·°F / Btu (m ² K / W)	U_o Btu/ft ² ·hr ·°F (W/m ² K)	R ft ² ·hr·°F / Btu (m ² K / W)	U Btu/ft ² ·hr ·°F (W/m ² K)	ψ Btu/ft hr °F (W/m K)
R-5 (0.88)	R-8.2 (1.44)	R-6.9 (1.21)	0.146 (0.83)	R-5.9 (1.05)	0.168 (0.96)	0.089 (0.153)
R-10 (1.76)	R-13.2 (2.32)	R-9.4 (1.66)	0.106 (0.60)	R-7.8 (1.37)	0.128 (0.73)	0.087 (0.152)
R-15 (2.64)	R-18.2 (3.20)	R-11.3 (1.99)	0.088 (0.50)	R-9.1 (1.61)	0.110 (0.62)	0.085 (0.147)
R-20 (3.52)	R-23.2 (4.08)	R-13.1 (2.31)	0.076 (0.43)	R-10.2 (1.79)	0.098 (0.56)	0.088 (0.152)
R-25 (4.40)	R-28.2 (4.96)	R-14.6 (2.56)	0.069 (0.39)	R-11.1 (1.95)	0.090 (0.51)	0.086 (0.149)

Temperature Indices

	R5	R10	R15	R20	R25	
T_{i1}	0.36	0.42	0.46	0.48	0.51	Min T on sheathing, along studs at girts and corner intersection
T_{i2}	0.76	0.83	0.86	0.89	0.90	Max T on sheathing, at steel studs, between girts, away from corner

Detail 5.6.5

Exterior and Interior Insulated 3 5/8" x 1 5/8" Steel Stud (16" o.c.) Wall Assembly with Horizontal Z-girts (24" o.c.) Supporting Metal Cladding and R-12 Batt Insulation in Stud Cavity – Corner Intersection

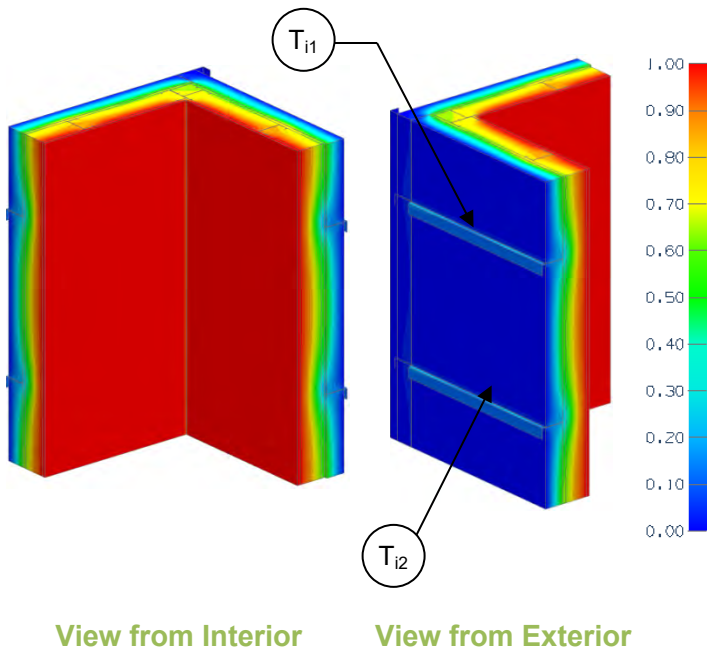

Thermal Performance Indicators

Assembly 1D (Nominal) R-Value	R_{1D}	R-14.2 (2.50 RSI) + exterior insulation
Transmittance / Resistance without Anomaly	U_o, R_o	“clear wall” U- and R-value, without corner
Transmittance / Resistance	U, R	U- and R-values for overall assembly
Surface Temperature Index ¹	T_i	0 = exterior temperature 1 = interior temperature
Linear Transmittance	ψ	Incremental increase in transmittance per linear length of corner

¹Assumptions and limitations for surface temperatures identified in ASHRAE 1365-RP

Nominal (1D) vs. Assembly Performance Indicators

Exterior Insulation 1D R-Value (RSI)	R_{1D} ft ² ·hr·°F / Btu (m ² K / W)	R_o ft ² ·hr·°F / Btu (m ² K / W)	U_o Btu/ft ² ·hr ·°F (W/m ² K)	R ft ² ·hr·°F / Btu (m ² K / W)	U Btu/ft ² ·hr ·°F (W/m ² K)	ψ Btu/ft ·hr·°F (W/m K)
R-10 (1.76)	R-24.2 (4.26)	R-16.3 (2.87)	0.061 (0.35)	R-11.3 (1.99)	0.089 (0.50)	0.105 (0.181)
R-15 (2.64)	R-29.2 (5.14)	R-18.5 (3.25)	0.054 (0.31)	R-12.7 (2.23)	0.079 (0.45)	0.098 (0.170)

Temperature Indices

	R10	R15	
T_{i1}	0.29	0.33	Min T on sheathing, along girts, between studs
T_{i2}	0.71	0.75	Max T on sheathing, along studs, between girts

Detail 5.6.6

Window Wall System – Transition to Exterior Insulated Steel Stud Wall Assembly with Horizontal Z-girts (24” o.c.) Supporting Metal Cladding & No Interior Stud Cavity Insulation

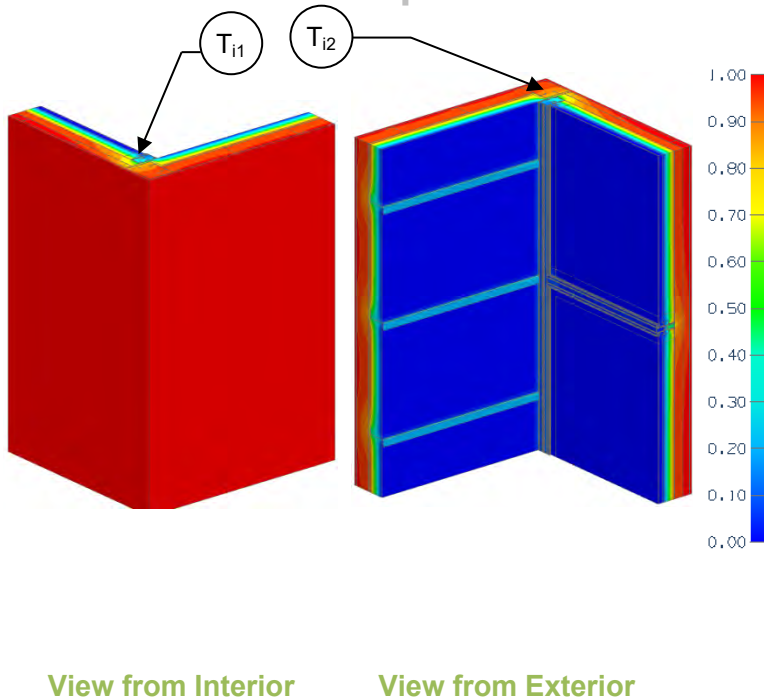

Thermal Performance Indicators

Assembly 1D (Nominal) R-Value	R_{1Dw}	Stud wall, R-3.2 (0.56 RSI) + exterior insulation
Assembly 1D (Nominal) R-Value	R_{1Ds}	Spandrel wall, R-3.6 (0.64 RSI) + backpan insulation
Transmittance / Resistance without Anomaly	U_w, R_w, U_s, R_s	“clear wall” U- and R-values for w = stud wall s = spandrel wall
Transmittance / Resistance	U, R	U- and R-values for overall assembly
Surface Temperature Index ¹	T_i	0 = exterior temperature 1 = interior temperature
Linear Transmittance	ψ	Incremental increase in transmittance per linear length of corner transition

¹Assumptions and limitations for surface temperatures identified in ASHRAE 1365-RP

Nominal (1D) vs. Assembly Performance Indicators

Base Assembly – Steel Stud Wall

Exterior Insulation 1D R-Value (RSI)	R_{1Dw} ft ² ·hr·°F / Btu (m ² K / W)	R_w ft ² ·hr·°F / Btu (m ² K / W)	U_w Btu/ft ² ·hr ·°F (W/m ² K)
R-15 (2.64)	R-18.2 (3.20)	R-11.3 (1.99)	0.088 (0.50)
R-25 (4.40)	R-28.2 (4.96)	R-14.5 (2.56)	0.069 (0.39)

Base Assembly – Spandrel Wall

Backpan Insulation 1D R-Value (RSI)	R_{1Ds} ft ² ·hr·°F / Btu (m ² K / W)	R_s ft ² ·hr·°F / Btu (m ² K / W)	U_s Btu/ft ² ·hr ·°F (W/m ² K)
R-16.8 (2.96)	R-20.4 (3.60)	R-7.7 (1.36)	0.130 (0.74)

Corner Linear Transmittance

Exterior Insulation 1D R-Value (RSI)	R ft ² ·hr·°F / Btu (m ² K / W)	U Btu/ft ² ·hr ·°F (W/m ² K)	ψ Btu/ft ·hr·°F (W/m K)
R-15 (2.64)	R-7.9 (1.38)	0.127 (0.72)	0.120 (0.207)
R-25 (4.40)	R-8.5 (1.49)	0.118 (0.67)	0.125 (0.217)

Temperature Indices

	R15	R25	
T_{i1}	0.63	0.64	Min T on sheathing, at corner
T_{i2}	0.39	0.39	Min T on interior side of spandrel, on vertical frame at corner

Detail 5.6.7

Window Wall System – Transition to Exterior Insulated Steel Stud Wall Assembly with Horizontal Z-girts (24” o.c.) Supporting Metal Cladding & Interior Sprayfoam and Fibreglass Batt Insulation

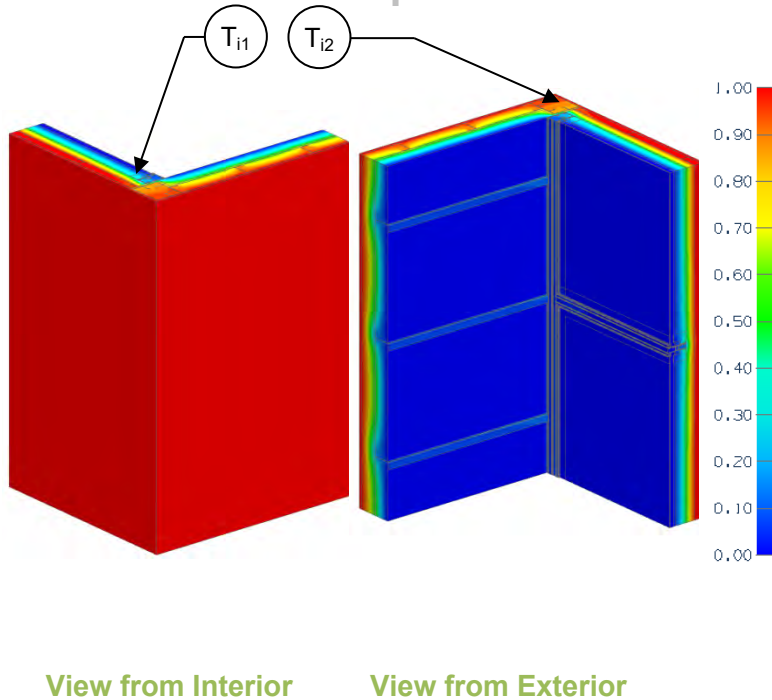

Thermal Performance Indicators

Assembly 1D (Nominal) R-Value	R_{1Dw}	Stud wall, R-14.3 (2.52 RSI) + exterior insulation
Assembly 1D (Nominal) R-Value	R_{1Ds}	Spandrel wall, R-14.7 (2.59 RSI) + backpan insulation
Transmittance / Resistance without Anomaly	U_w, R_w, U_s, R_w	“clear wall” U- and R-values for w = stud wall s = spandrel wall
Transmittance / Resistance	U, R	U- and R-values for overall assembly
Surface Temperature Index ¹	T_i	0 = exterior temperature 1 = interior temperature
Linear Transmittance	ψ	Incremental increase in transmittance per linear length of corner transition

¹Assumptions and limitations for surface temperatures identified in ASHRAE 1365-RP

Nominal (1D) vs. Assembly Performance Indicators

Base Assembly – Steel Stud Wall

Exterior Insulation 1D R-Value (RSI)	R_{1Dw} ft ² ·hr·°F / Btu (m ² K / W)	R_w ft ² ·hr·°F / Btu (m ² K / W)	U_w Btu/ft ² ·hr ·°F (W/m ² K)
R-15 (2.64)	R-29.2 (5.14)	R-18.5 (3.25)	0.054 (0.31)
R-25 (4.40)	R-39.2 (6.90)	R-22.1 (3.90)	0.045 (0.26)

Base Assembly – Spandrel Wall

Backpan Insulation 1D R-Value (RSI)	R_{1Ds} ft ² ·hr·°F / Btu (m ² K / W)	R_s ft ² ·hr·°F / Btu (m ² K / W)	U_s Btu/ft ² ·hr ·°F (W/m ² K)
R-16.8 (2.96)	R-31.5 (5.55)	R-17.5 (3.08)	0.057 (0.33)

Corner Linear Transmittance

Exterior Insulation 1D R-Value (RSI)	R ft ² ·hr·°F / Btu (m ² K / W)	U Btu/ft ² ·hr ·°F (W/m ² K)	ψ Btu/ft ·hr·°F (W/m K)
R-15 (2.64)	R-12.9 (2.27)	0.078 (0.44)	0.137 (0.237)
R-25 (4.40)	R-13.7 (2.41)	0.073 (0.42)	0.138 (0.238)

Temperature Indices

	R15	R25	
T_{i1}	0.57	0.58	Min T on sheathing, at corner

T_{i2}	0.90	0.91	Min T on interior side of spandrel, on sprayfoam in front of vertical frame
----------	------	------	---

Detail 5.7.1

Exterior and Interior Insulated 3 5/8" x 1 5/8" Steel Stud (16" o.c.) Wall Assembly with Horizontal Z-Girts (24" o.c.) Supporting Metal Cladding and R-12 Batt Insulation in Stud Cavity – Structural Steel Column & Cantilever Beam Intersection (Canopy Support)

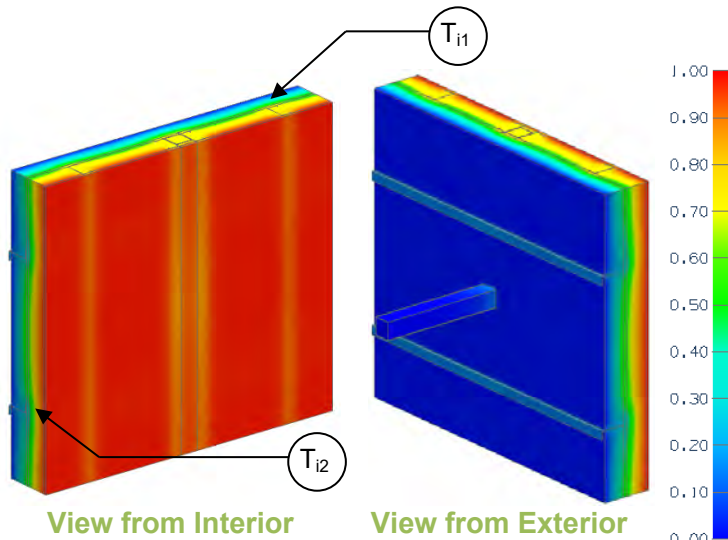

Thermal Performance Indicators

Assembly 1D (Nominal) R-Value	R_{1D}	R-14.2 (2.5 RSI) + exterior insulation
Transmittance / Resistance without Anomaly	U_o, R_o	"clear wall" U- and R-value, without beam and post
Transmittance / Resistance	U_c, R_c	U- and R-values for stud wall with column
Transmittance / Resistance	U, R	U- and R-values for overall assembly
Surface Temperature Index ¹	T_i	0 = exterior temperature 1 = interior temperature
Linear Transmittance	ψ	Incremental increase in transmittance per length of steel column
Point Transmittance	χ	Incremental increase in transmittance for steel beam attached to post

¹Assumptions and limitations for surface temperatures identified in ASHRAE 1365-RP

Nominal (1D) vs. Assembly Performance Indicators

Base Assembly – Wall

Exterior Insulation 1D R-Value (RSI)	R_{1D} ft ² ·hr·°F / Btu (m ² K / W)	R_o ft ² ·hr·°F / Btu (m ² K / W)	U_o Btu/ft ² ·hr·°F (W/m ² K)
R-5 (0.88)	R-19.2 (3.38)	R-13.4 (2.36)	0.075 (0.42)
R-15 (2.64)	R-29.2 (5.14)	R-18.5 (3.25)	0.054 (0.31)
R-25 (4.40)	R-39.2 (6.90)	R-22.1 (3.90)	0.045 (0.26)

Column Linear Transmittance

R_c ft ² ·hr·°F / Btu (m ² K / W)	U_c Btu/ft ² ·hr·°F (W/m ² K)	ψ Btu/ft hr °F (W/m K)
R-12.1 (2.13)	0.082 (0.47)	0.034 (0.060)
R-16.6 (2.92)	0.060 (0.34)	0.027 (0.047)
R-19.9 (3.49)	0.050 (0.29)	0.023 (0.040)

Beam Point Transmittance

Exterior Insulation 1D R-Value (RSI)	R ft ² ·hr·°F / Btu (m ² K / W)	U Btu/ft ² ·hr·°F (W/m ² K)	χ Btu/hr °F (W/K)
R-5 (0.88)	R- 11.0 (1.93)	0.091 (0.52)	0.16 (0.08)
R-15 (2.64)	R- 14.4 (2.54)	0.069 (0.39)	0.16 (0.08)
R-25 (4.40)	R-16.9 (2.97)	0.059 (0.34)	0.16 (0.08)

Temperature Indices

	R5	R15	R25	
T_{i1}	0.23	0.35	0.42	Min T on sheathing, along girt between studs, away from post
T_{i2}	0.58	0.71	0.76	Max T on sheathing, at studs, between z girts, away from post

Detail 5.7.2

Exterior and Interior Insulated 3 5/8" x 1 5/8" Steel Stud (16" o.c.) Wall Assembly with Horizontal Z-girts (24" o.c.) Supporting Metal Cladding and R-12 Batt Insulation in Stud Cavity – Structural Steel Floor Intersection with Uninterrupted Beam

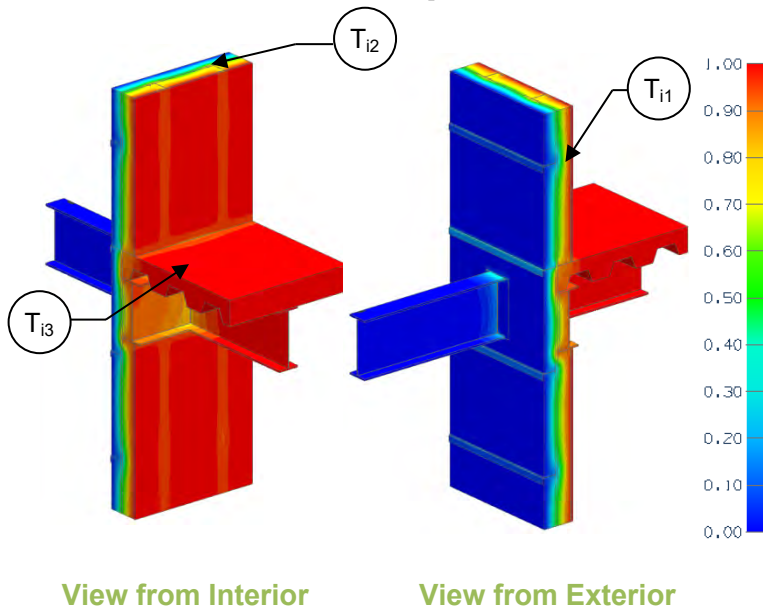

Thermal Performance Indicators

Assembly 1D (Nominal) R-Value	R_{1D}	R-14.3 (2.52 RSI) + exterior insulation
Transmittance / Resistance without Anomaly	U_o, R_o	"clear wall" U- and R-value without slab or beam
Transmittance / Resistance	U_s, R_s, U_t, R_t	U and R-values for s = steel stud wall + slab t = combined wall + slab + beam
Surface Temperature Index ¹	T_i	0 = exterior temperature 1 = interior temperature
Linear Transmittance	ψ	Incremental increase in transmittance per linear length of floor slab
Point Transmittance	χ	Incremental increase in transmittance for beam penetration

¹Assumptions and limitations for surface temperatures identified in ASHRAE 1365-RP

Nominal (1D) vs. Assembly Performance Indicators

Base Assembly – Wall

Wall Exterior Insulation 1D R-Value (RSI)	R_{1D} ft ² ·hr·°F / Btu (m ² K / W)	R_o ft ² ·hr·°F / Btu (m ² K / W)	U_o Btu/ft ² ·hr ·°F (W/m ² K)
R-15 (2.64)	R-29.3 (5.16)	R-18.6 (3.28)	0.054 (0.31)

Slab Linear Transmittance

R_s ft ² ·hr·°F / Btu (m ² K / W)	U_s Btu/ft ² ·hr ·°F (W/m ² K)	ψ Btu/ft hr °F (W/m K)
R-15.6 (2.74)	0.064 (0.36)	0.084 (0.146)

Beam Point Transmittance

Wall Exterior Insulation 1D R-Value (RSI)	R_t ft ² ·hr·°F / Btu (m ² K / W)	U_t Btu/ft ² ·hr ·°F (W/m ² K)	χ Btu/hr °F (W/K)
R-15 (2.64)	R-6.9 (1.21)	0.146 (0.83)	1.73 (0.92)

Temperature Indices

T_{i1}	0.35	Min T on sheathing away from slab, between studs at girts
T_{i2}	0.73	Max T on sheathing away from slab, between girts at studs
T_{i3}	0.52	Min T on beam exposed to interior air, top flange at I-beam intersection

Detail 5.7.3

Exterior and Interior Insulated 3 5/8" x 1 5/8" Steel Stud (16" o.c.) Wall Assembly with Horizontal Z-girts (24" o.c.) Supporting Metal Cladding and R-12 Batt Insulation in Stud Cavity – Structural Steel Floor Intersection with Isolator Pad

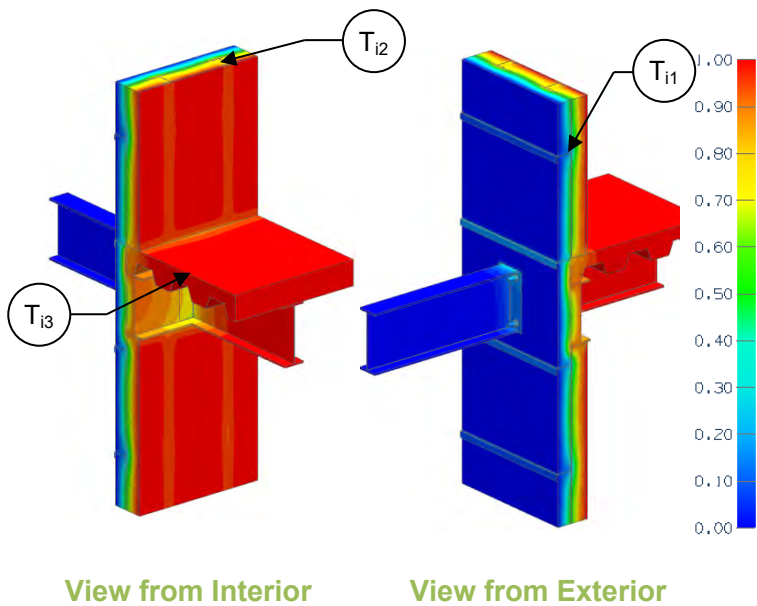

Thermal Performance Indicators

Assembly 1D (Nominal) R-Value	R_{1D}	R-14.3 (2.52 RSI) + exterior insulation
Transmittance / Resistance without Anomaly	U_o, R_o	“clear wall” U- and R-value without slab or beam
Transmittance / Resistance	U_s, R_s, U_t, R_t	U and R-values for s = steel stud wall + slab t = combined wall + slab + beam
Surface Temperature Index ¹	T_i	0 = exterior temperature 1 = interior temperature
Linear Transmittance	ψ	Incremental increase in transmittance per linear length of floor slab
Point Transmittance	χ	Incremental increase in transmittance for beam penetration

¹Assumptions and limitations for surface temperatures identified in ASHRAE 1365-RP

Nominal (1D) vs. Assembly Performance Indicators

Base Assembly – Wall

Wall Exterior Insulation 1D R-Value (RSI)	R_{1D} ft ² ·hr·°F / Btu (m ² K / W)	R_o ft ² ·hr·°F / Btu (m ² K / W)	U_o Btu/ft ² ·hr·°F (W/m ² K)
R-15 (2.64)	R-29.3 (5.16)	R-18.6 (3.28)	0.054 (0.31)

Beam Point Transmittance

Thermal Isolator Pad	R_t ft ² ·hr·°F / Btu (m ² K / W)	U_t Btu/ft ² ·hr·°F (W/m ² K)	χ Btu/hr·°F (W/K)
5 mm pad, stainless steel bolts	R-6.0 (1.06)	0.167 (0.95)	2.17 (1.15)
5 mm pad, steel bolts	R-5.9 (1.04)	0.170 (0.97)	2.24 (1.19)
5 mm pad, stainless steel bolts, w/ R10 outboard of plates	R-6.4 (1.13)	0.156 (0.89)	1.80 (1.03)
10 mm pad, stainless steel bolts	R-6.7 (1.17)	0.150 (0.85)	1.82 (0.97)
10 mm pad, steel bolts	R-6.5 (1.15)	0.153 (0.87)	1.89 (1.00)

Slab Linear Transmittance

Wall Exterior Insulation 1D R-Value (RSI)	R_s ft ² ·hr·°F / Btu (m ² K / W)	U_s Btu/ft ² ·hr·°F (W/m ² K)	ψ Btu/ft hr·°F (W/m K)
R-15 (2.64)	R-15.6 (2.74)	0.064 (0.36)	0.084 (0.146)

Temperature Indices

	5 mm pad, stainless bolts	5 mm pad, steel bolts	5 mm pad, stainless bolts, w/ R10	10 mm pad, stainless bolts	10 mm pad, steel bolts	
T_{i1}	0.35	0.35	0.35	0.35	0.35	Min T on sheathing away from slab, between studs at girts
T_{i2}	0.73	0.73	0.73	0.73	0.73	Max T on sheathing away from slab, between girts at studs
T_{i3}	0.33	0.32	0.39	0.42	0.41	Min T on beam exposed to interior air, top flange at I-beam intersection

Detail 5.7.4

Exterior and Interior Insulated 3 5/8" x 1 5/8" Steel Stud (16" o.c.) Wall Assembly with Horizontal Z-girts (24" o.c.) Supporting Metal Cladding and R-12 Batt Insulation in Stud Cavity – Structural Steel Floor Intersection with Isokorb S22 Thermally Broken Beam

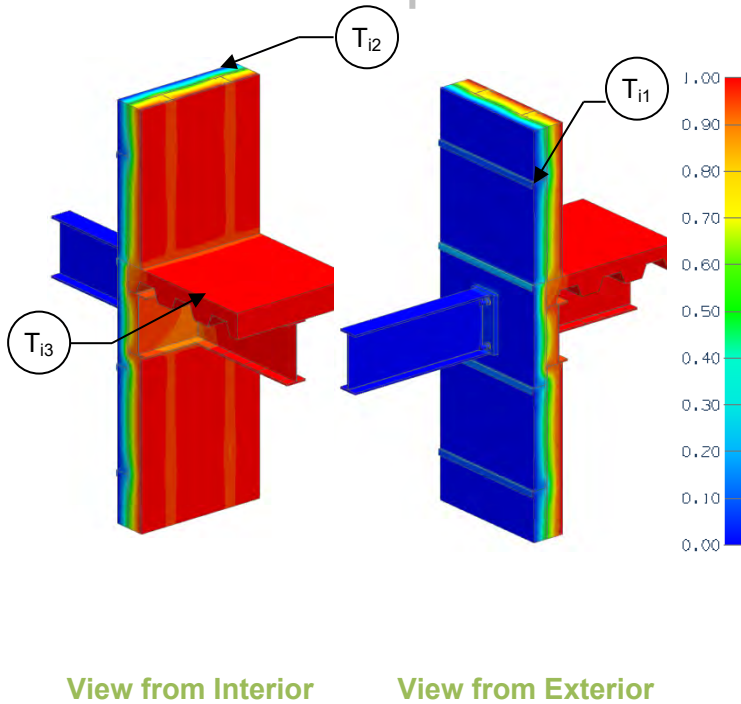

Thermal Performance Indicators

Assembly 1D (Nominal) R-Value	R_{1D}	R-14.3 (2.52 RSI) + exterior insulation
Transmittance / Resistance without Anomaly	U_o, R_o	"clear wall" U- and R-value without slab or beam
Transmittance / Resistance	U_s, R_s, U_t, R_t	U and R-values for s = steel stud wall + slab t = combined wall + slab + beam
Surface Temperature Index ¹	T_i	0 = exterior temperature 1 = interior temperature
Linear Transmittance	ψ	Incremental increase in transmittance per linear length of floor slab
Point Transmittance	χ	Incremental increase in transmittance for beam penetration

¹Assumptions and limitations for surface temperatures identified in ASHRAE 1365-RP

Nominal (1D) vs. Assembly Performance Indicators

Base Assembly – Wall

Wall Exterior Insulation 1D R-Value (RSI)	R_{w1D} ft ² ·hr·°F / Btu (m ² K / W)	R_o ft ² ·hr·°F / Btu (m ² K / W)	U_o Btu/ft ² ·hr·°F (W/m ² K)
R-15 (2.64)	R-29.2 (5.14)	R-18.5 (3.25)	0.054 (0.31)

Slab Transmittance

R_s ft ² ·hr·°F / Btu (m ² K / W)	U_s Btu/ft ² ·hr·°F (W/m ² K)	ψ Btu/ft hr °F (W/m K)
R-15.6 (2.74)	0.064 (0.36)	0.084 (0.146)

Beam Point Transmittance

Wall Exterior Insulation 1D R-Value (RSI)	R_t ft ² ·hr·°F / Btu (m ² K / W)	U_t Btu/ft ² ·hr·°F (W/m ² K)	χ Btu/hr °F (W/K)
R-15 (2.64)	R-9.4 (1.65)	0.107 (0.61)	0.91 (0.48)

Temperature Indices

T_{i1}	0.32	Min T on sheathing away from slab, between studs at girts
T_{i2}	0.89	Max T on sheathing away from slab, between girts at studs
T_{i3}	0.79	Min T on beam exposed to interior air, top flange at I-beam intersection

Detail 5.7.5

Exterior Insulated 3 5/8" x 1 5/8" Steel Stud (16" o.c.) Wall Assembly with Intermittent Vertical Z-girts (16" o.c.) Supporting Metal Cladding – Concrete Floor to Steel Beam Connection

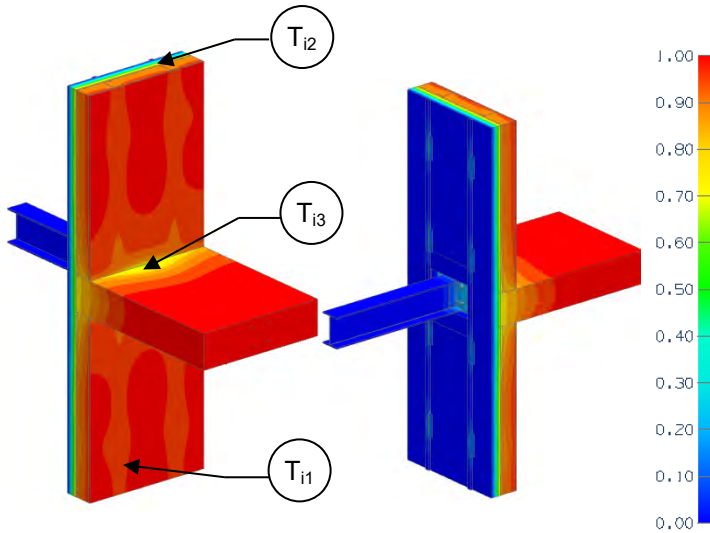

View from Interior

View from Exterior

Thermal Performance Indicators

Assembly 1D (Nominal) R-Value	R_{1D}	R-3.2 (0.56 RSI) + exterior insulation
Transmittance / Resistance without Anomaly	U_o, R_o	"clear wall" U- and R-value without slab or beam
Transmittance / Resistance	U_s, R_s, U_t, R_t	U and R-values for s = steel stud wall + slab t = combined wall + slab + beam
Surface Temperature Index ¹	T_i	0 = exterior temperature 1 = interior temperature
Linear Transmittance	ψ	Incremental increase in transmittance per linear length of floor slab
Point Transmittance	χ	Incremental increase in transmittance for beam penetration

¹Assumptions and limitations for surface temperatures identified in ASHRAE 1365-RP

Nominal (1D) vs. Assembly Performance Indicators

Base Assembly – Wall

Exterior Insulation 1D R-Value (RSI)	R_{1D} ft ² ·hr·°F / Btu (m ² K / W)	R_o ft ² ·hr·°F / Btu (m ² K / W)	U_o Btu/ft ² ·hr ·°F (W/m ² K)
R-15 (2.64)	R-18.2 (3.20)	R-13.8 (2.44)	0.072 (0.41)

Slab Transmittance

R_s ft ² ·hr·°F / Btu (m ² K / W)	U_s Btu/ft ² ·hr ·°F (W/m ² K)	ψ Btu/ft hr °F (W/m K)
R-12.7 (2.24)	0.079 (0.45)	0.052 (0.090)

Beam Point Transmittance

Exterior Insulation 1D R-Value (RSI)	R_t ft ² ·hr·°F / Btu (m ² K / W)	U_t Btu/ft ² ·hr ·°F (W/m ² K)	χ Btu/hr °F (W/K)
R-15 (2.64)	R-7.3 (1.28)	0.137 (0.78)	1.24 (0.66)

Temperature Indices

T_{i1}	0.44	Min T on sheathing, at slab, in line with beam
T_{i2}	0.88	Max T on sheathing, at studs, between clips
T_{i3}	0.40	Min T on slab exposed to interior air, at sheathing, in line with beam

Detail 5.7.6

Exterior Insulated 3 5/8" x 1 5/8" Steel Stud (16" o.c.) Wall Assembly with Intermittent Vertical Z-girts (16" o.c.) Supporting Metal Cladding – Concrete Floor to Steel Beam with a Thermal Isolator Pad Connection

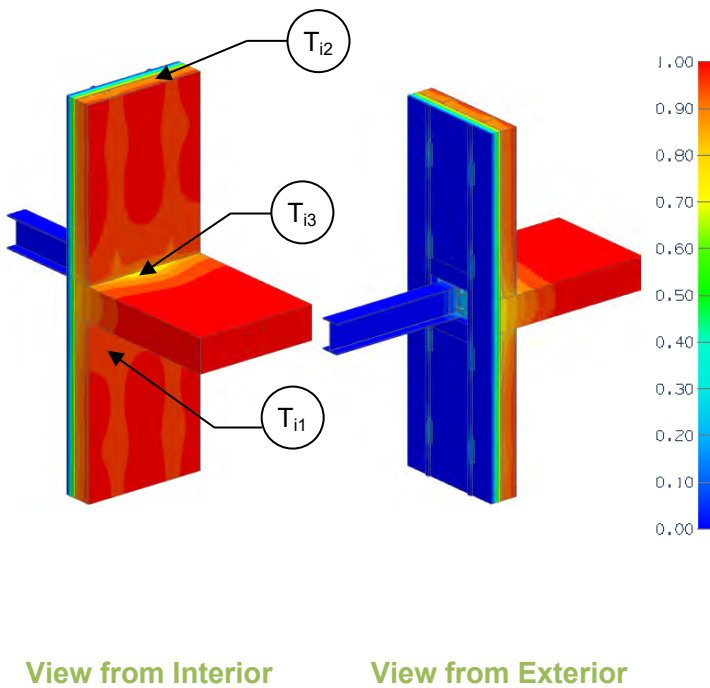

Thermal Performance Indicators

Assembly 1D (Nominal) R-Value	R_{1D}	R-3.2 (0.56 RSI) + exterior insulation
Transmittance / Resistance without Anomaly	U_o, R_o	"clear wall" U- and R-value without slab or beam
Transmittance / Resistance	U_s, R_s, U_t, R_t	U and R-values for s = steel stud wall + slab t = combined wall + slab + beam
Surface Temperature Index ¹	T_i	0 = exterior temperature 1 = interior temperature
Linear Transmittance	ψ	Incremental increase in transmittance per linear length of floor slab
Point Transmittance	χ	Incremental increase in transmittance for beam penetration

¹Assumptions and limitations for surface temperatures identified in ASHRAE 1365-RP

Nominal (1D) vs. Assembly Performance Indicators

Base Assembly – Wall

Exterior Insulation 1D R-Value (RSI)	R_{1D} ft ² ·hr·°F / Btu (m ² K / W)	R_o ft ² ·hr·°F / Btu (m ² K / W)	U_o Btu/ft ² ·hr·°F (W/m ² K)
R-15 (2.64)	R-18.2 (3.20)	R-13.8 (2.44)	0.072 (0.41)

Slab Transmittance

R_s ft ² ·hr·°F / Btu (m ² K / W)	U_s Btu/ft ² ·hr·°F (W/m ² K)	ψ Btu/ft hr °F (W/m K)
R-12.7 (2.24)	0.079 (0.45)	0.052 (0.090)

Beam Point Transmittance

Exterior Insulation 1D R-Value (RSI)	R_t ft ² ·hr·°F / Btu (m ² K / W)	U_t Btu/ft ² ·hr·°F (W/m ² K)	χ Btu/hr °F (W/K)
R-15 (2.64)	R-8.2 (1.45)	0.121 (0.69)	0.91 (0.48)

Temperature Indices

T_{i1}	0.44	Min T on sheathing, at slab, in line with beam
T_{i2}	0.88	Max T on sheathing, at studs, between clips
T_{i3}	0.54	Min T on slab exposed to interior air, at sheathing, in line with beam

Detail 5.7.7

Exterior Insulated 3 5/8" x 1 5/8" Steel Stud (16" o.c.) Wall Assembly with Intermittent Vertical Z-girts (16" o.c.) Supporting Metal Cladding – Concrete Floor to Steel Beam with Isokorb KS14 Connection

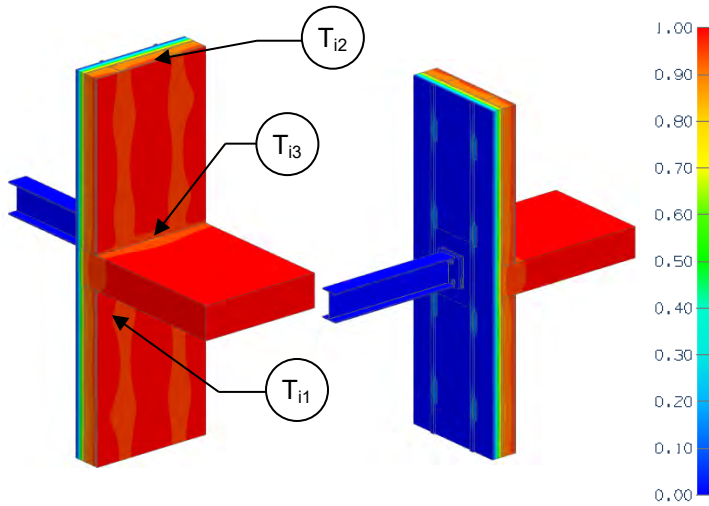

View from Interior

View from Exterior

Thermal Performance Indicators

Assembly 1D (Nominal) R-Value	R_{1D}	R-3.2 (0.56 RSI) + exterior insulation
Transmittance / Resistance without Anomaly	U_o, R_o	“clear wall” U- and R-value without slab or beam
Transmittance / Resistance	U_s, R_s, U_t, R_t	U and R-values for s = steel stud wall + slab t = combined wall + slab + beam
Surface Temperature Index ¹	T_i	0 = exterior temperature 1 = interior temperature
Linear Transmittance	ψ_s	Incremental increase in transmittance per linear length of floor slab
Point Transmittance	χ	Incremental increase in transmittance for beam penetration

¹Assumptions and limitations for surface temperatures identified in ASHRAE 1365-RP

Nominal (1D) vs. Assembly Performance Indicators

Base Assembly – Wall

Exterior Insulation 1D R-Value (RSI)	R_{1D} ft ² ·hr·°F / Btu (m ² K / W)	R_o ft ² ·hr·°F / Btu (m ² K / W)	U_o Btu/ft ² ·hr·°F (W/m ² K)
R-15 (2.64)	R-18.2 (3.20)	R-13.8 (2.44)	0.072 (0.41)

Slab Transmittance

R_s ft ² ·hr·°F / Btu (m ² K / W)	U_s Btu/ft ² ·hr·°F (W/m ² K)	ψ_s Btu/ft hr °F (W/m K)
R-12.7 (2.24)	0.079 (0.45)	0.052 (0.090)

Beam Point Transmittance

Exterior Insulation 1D R-Value (RSI)	R_t ft ² ·hr·°F / Btu (m ² K / W)	U_t Btu/ft ² ·hr·°F (W/m ² K)	χ Btu/hr °F (W/K)
R-15 (2.64)	R-12.2 (2.14)	0.082 (0.47)	0.07 (0.04)

Temperature Indices

T_{i1}	0.44	Min T on sheathing, at slab, in line with beam
T_{i2}	0.88	Max T on sheathing, at studs, between clips
T_{i3}	0.84	Min T on slab exposed to interior air, at sheathing, in line with beam

Detail 5.7.8

Exterior and Interior Insulated 3 5/8" x 1 5/8" Steel Stud (16" o.c.) Wall Assembly with Horizontal Z-girts (24" o.c.) Supporting Metal Cladding and R-12 Batt Insulation in Stud Cavity – Structural Steel Floor Intersection with Beam Thermal Break

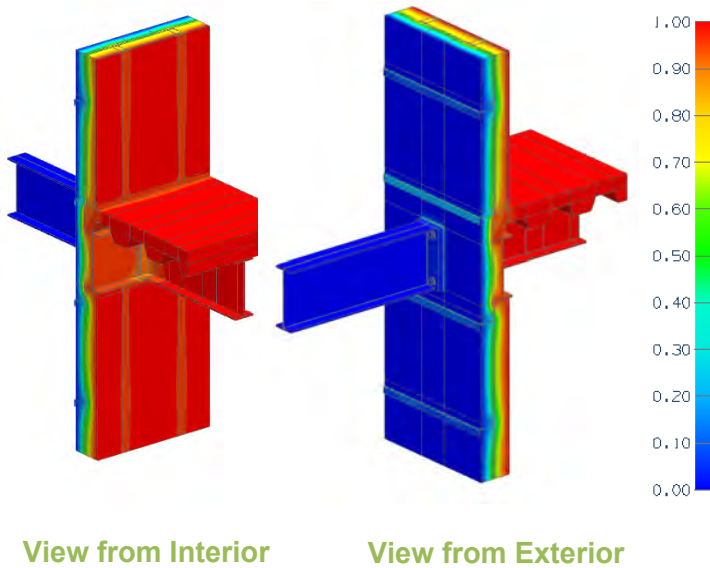

Thermal Performance Indicators

Assembly 1D (Nominal) R-Value	R_{1D}	R-14.3 (2.52 RSI) + exterior insulation
Transmittance / Resistance without Anomaly	U_o, R_o	"clear wall" U- and R-value without slab or beam
Transmittance / Resistance	U_s, R_s, U_t, R_t	U and R-values for s = steel stud wall + slab t = combined wall + slab + beam
Surface Temperature Index	T_i	0 = exterior temperature 1 = interior temperature
Linear Transmittance	ψ	Incremental increase in transmittance per linear length of floor slab
Point Transmittance	χ	Incremental increase in transmittance for beam penetration

¹Assumptions and limitations for surface temperatures identified in ASHRAE 1365-RP

Scenario

Scenario	
1	25mm Armatherm FRR between pressure plates
2	25mm Armatherm FRR with Stainless Steel Fasteners
3	25mm Armatherm FRR with Stainless Steel Fasteners and Armatherm bushings/washers
4	50mm Armatherm with Stainless Steel Fasteners and Armatherm bushings/washers

Nominal (1D) vs. Assembly Performance Indicators

Base Assembly – Wall

Wall Exterior Insulation 1D R-Value (RSI)	R_{1D} ft ² ·hr·°F / Btu (m ² K / W)	R_o ft ² ·hr·°F / Btu (m ² K / W)	U_o Btu/ft ² ·hr·°F (W/m ² K)
R-15 (2.64)	R-29.2 (5.14)	R-18.5 (3.25)	0.054 (0.31)

Slab Linear Transmittance

Wall Exterior Insulation 1D R-Value (RSI)	R_s ft ² ·hr·°F / Btu (m ² K / W)	U_s Btu/ft ² ·hr·°F (W/m ² K)	ψ Btu/ft hr °F (W/m K)
R-15 (2.64)	R-15.6 (2.74)	0.064 (0.36)	0.084 (0.146)

Beam Point Transmittance

Scenario	R_t ft ² ·hr·°F / Btu (m ² K / W)	U_t Btu/ft ² ·hr·°F (W/m ² K)	χ Btu/hr °F (W/K)
1	R-7.3 (1.28)	0.138 (0.78)	1.56 (0.83)
2	R-8.4 (1.48)	0.119 (0.68)	1.16 (0.62)
3	R-9.2 (1.61)	0.109 (0.62)	0.95 (0.50)
4	R-10.2 (1.79)	0.098 (0.56)	0.72 (0.38)

Detail 5.7.9

Exterior and Interior Insulated 3 5/8" x 1 5/8" Steel Stud (16" o.c.) Wall Assembly with Horizontal Z-girts (24" o.c.) Supporting Metal Cladding and R-12 Batt Insulation in Stud Cavity – Structural Steel Floor Intersection with Aerolon Coating

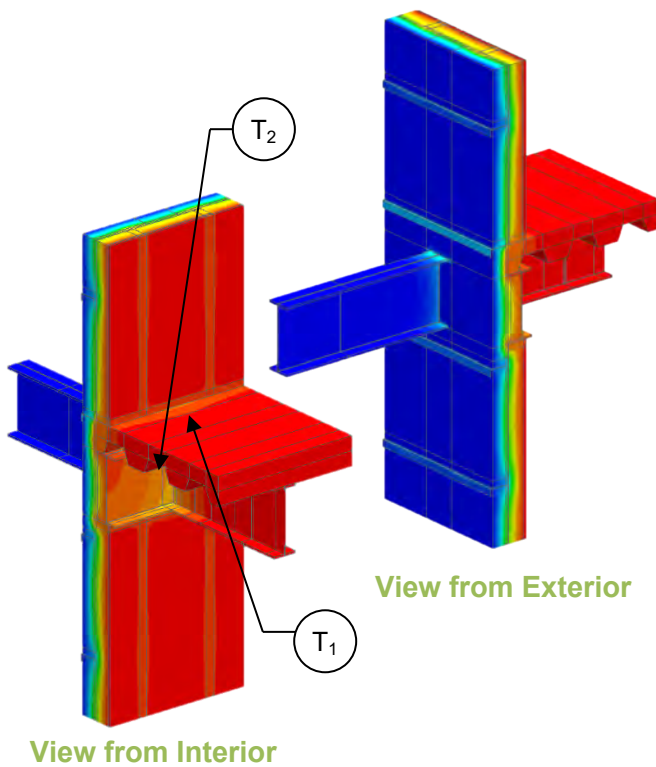

Thermal Performance Indicators

Assembly 1D (Nominal) R-Value	R_{1D}	R-14.3 (2.52 RSI) + exterior insulation
Transmittance / Resistance without Anomaly	U_o, R_o	"clear wall" U- and R-value without slab or beam
Transmittance / Resistance	U_s, R_s, U_t, R_t	U and R-values for s = steel stud wall + slab t = combined wall + slab + beam
Surface Temperature Index ¹	T_i	0 = exterior temperature 1 = interior temperature
Linear Transmittance	ψ	Incremental increase in transmittance per linear length of floor slab
Point Transmittance	χ	Incremental increase in transmittance for beam penetration

¹Assumptions and limitations for surface temperatures identified in ASHRAE 1365-RP

Nominal (1D) vs. Assembly Performance Indicators

Base Assembly – Wall

Wall Exterior Insulation 1D R-Value (RSI)	R_{1D} ft ² ·hr·°F / Btu (m ² K / W)	R_o ft ² ·hr·°F / Btu (m ² K / W)	U_o Btu/ft ² ·hr ·°F (W/m ² K)
R-15 (2.64)	R-29.3 (5.16)	R-18.5 (3.25)	0.054 (0.31)

Slab Linear Transmittance

Wall Exterior Insulation 1D R-Value (RSI)	R_s ft ² ·hr·°F / Btu (m ² K / W)	U_s Btu/ft ² ·hr ·°F (W/m ² K)	ψ Btu/ft hr °F (W/m K)
R-15 (2.64)	R-15.6 (2.75)	0.064 (0.36)	0.083 (0.143)

Beam Point Transmittance

R_t ft ² ·hr·°F / Btu (m ² K / W)	U_t Btu/ft ² ·hr ·°F (W/m ² K)	χ Btu/hr °F (W/K)
R-8.4 (1.48)	0.119 (0.68)	1.17 (0.62)

Temperature Indices

T_1	0.59	Min T on coating at top flange of steel beam exposed to interior air
T_2	0.78	Min T on coating at underside of beam exposed to interior

Detail 5.7.10

Exterior Insulated 6" x 1 5/8" Steel Stud (16" o.c.) Wall Assembly with FRP Vertical Brackets and Rail System Supporting Metal Cladding – Structural Steel Column & Knife Edge Cable Support Intersection

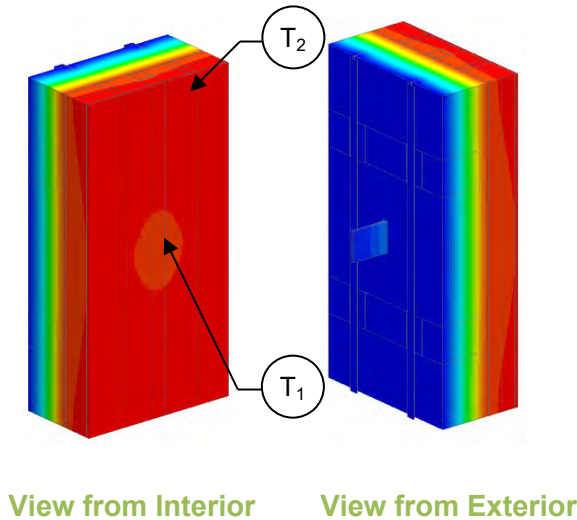

Thermal Performance Indicators

1.00	<table border="1"> <tr> <td>Assembly 1D (Nominal) R-Value</td> <td>R_{1D}</td> <td>R-3.2 (0.56 RSI) + exterior insulation</td> </tr> <tr> <td>Transmittance / Resistance without Anomaly</td> <td>U_o, R_o</td> <td>“clear wall” U- and R-value without column and knife edge</td> </tr> <tr> <td>Transmittance / Resistance</td> <td>U_c, R_c</td> <td>U- and R-values for column</td> </tr> <tr> <td>Transmittance / Resistance</td> <td>U, R</td> <td>U- and R-values for overall assembly</td> </tr> <tr> <td>Surface Temperature Index¹</td> <td>T_i</td> <td>0 = exterior temperature 1 = interior temperature</td> </tr> <tr> <td>Linear Transmittance</td> <td>ψ</td> <td>Incremental increase in transmittance per linear length of column</td> </tr> <tr> <td>Point Transmittance</td> <td>χ</td> <td>Incremental increase in transmittance for knife edge penetration</td> </tr> </table>	Assembly 1D (Nominal) R-Value	R_{1D}	R-3.2 (0.56 RSI) + exterior insulation	Transmittance / Resistance without Anomaly	U_o, R_o	“clear wall” U- and R-value without column and knife edge	Transmittance / Resistance	U_c, R_c	U- and R-values for column	Transmittance / Resistance	U, R	U- and R-values for overall assembly	Surface Temperature Index ¹	T_i	0 = exterior temperature 1 = interior temperature	Linear Transmittance	ψ	Incremental increase in transmittance per linear length of column	Point Transmittance	χ	Incremental increase in transmittance for knife edge penetration	0.90
Assembly 1D (Nominal) R-Value		R_{1D}	R-3.2 (0.56 RSI) + exterior insulation																				
Transmittance / Resistance without Anomaly		U_o, R_o	“clear wall” U- and R-value without column and knife edge																				
Transmittance / Resistance		U_c, R_c	U- and R-values for column																				
Transmittance / Resistance		U, R	U- and R-values for overall assembly																				
Surface Temperature Index ¹		T_i	0 = exterior temperature 1 = interior temperature																				
Linear Transmittance		ψ	Incremental increase in transmittance per linear length of column																				
Point Transmittance		χ	Incremental increase in transmittance for knife edge penetration																				
0.80	0.70																						
0.70	0.60																						
0.60	0.50																						
0.50	0.40																						
0.40	0.30																						
0.30	0.20																						
0.20	0.10																						
0.10	0.00																						

¹Assumptions and limitations for surface temperatures identified in ASHRAE 1365-RP

Nominal (1D) vs. Assembly Performance Indicators

Base Assembly – Wall

Exterior Insulation 1D R-Value (RSI)	R_{1D} ft ² ·hr·°F / Btu (m ² K / W)	R_o ft ² ·hr·°F / Btu (m ² K / W)	U_o Btu/ft ² ·hr ·°F (W/m ² K)
R-42 (7.40)	R-45.2 (7.96)	R-40.0 (7.04)	0.025 (0.14)

Column Linear Transmittance

R_c ft ² ·hr·°F / Btu (m ² K / W)	U_c Btu/ft ² ·hr ·°F (W/m ² K)	ψ Btu/ft hr °F (W/m K)
R-39.9 (7.04)	0.025 (0.14)	0.000009 (0.00015)

Knife Edge Point Transmittance

Exterior Insulation 1D R-Value (RSI)	R ft ² ·hr·°F / Btu (m ² K / W)	U Btu/ft ² ·hr ·°F (W/m ² K)	χ Btu/hr °F (W/K)
R-42 (7.40)	R-22.4 (3.95)	0.045 (0.25)	0.278 (0.147)

Temperature Indices

T_1	0.56	Min T on sheathing beside knife edge, at column
T_2	0.94	Max T on sheathing, at studs, away from knife edge

Detail 5.7.11

Exterior and Interior Insulated 6" x 1 5/8" Steel Stud (16" o.c.) Wall Assembly with FRP Vertical Brackets and Rail System Supporting Metal Cladding with R-19 Batt in Stud Cavity – Structural Steel Column & Knife Edge Cable Support Intersection

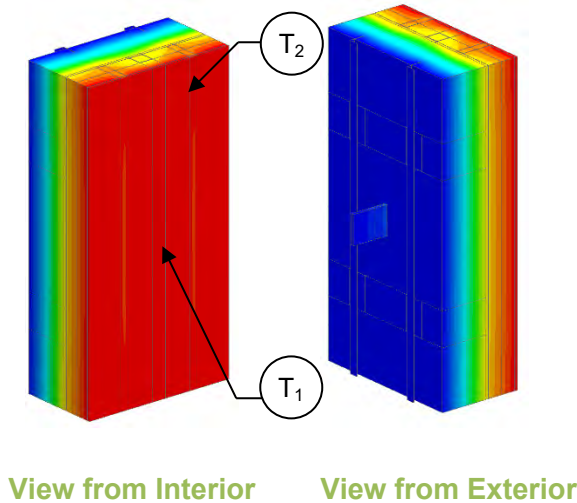

Thermal Performance Indicators

1.00	<table border="1"> <tr> <td>Assembly 1D (Nominal) R-Value</td> <td>R_{1D}</td> <td>R-21.3 (3.75 RSI) + exterior insulation</td> </tr> <tr> <td>Transmittance / Resistance without Anomaly</td> <td>U_o, R_o</td> <td>"clear wall" U- and R-value without column and knife edge</td> </tr> <tr> <td>Transmittance / Resistance</td> <td>U_c, R_c</td> <td>U- and R-values for column</td> </tr> <tr> <td>Transmittance / Resistance</td> <td>U, R</td> <td>U- and R-values for overall assembly</td> </tr> <tr> <td>Surface Temperature Index¹</td> <td>T_i</td> <td>0 = exterior temperature 1 = interior temperature</td> </tr> <tr> <td>Linear Transmittance</td> <td>ψ</td> <td>Incremental increase in transmittance per linear length of column</td> </tr> <tr> <td>Point Transmittance</td> <td>χ</td> <td>Incremental increase in transmittance for knife edge penetration</td> </tr> </table>	Assembly 1D (Nominal) R-Value	R_{1D}	R-21.3 (3.75 RSI) + exterior insulation	Transmittance / Resistance without Anomaly	U_o, R_o	"clear wall" U- and R-value without column and knife edge	Transmittance / Resistance	U_c, R_c	U- and R-values for column	Transmittance / Resistance	U, R	U- and R-values for overall assembly	Surface Temperature Index ¹	T_i	0 = exterior temperature 1 = interior temperature	Linear Transmittance	ψ	Incremental increase in transmittance per linear length of column	Point Transmittance	χ	Incremental increase in transmittance for knife edge penetration
Assembly 1D (Nominal) R-Value		R_{1D}	R-21.3 (3.75 RSI) + exterior insulation																			
Transmittance / Resistance without Anomaly		U_o, R_o	"clear wall" U- and R-value without column and knife edge																			
Transmittance / Resistance		U_c, R_c	U- and R-values for column																			
Transmittance / Resistance		U, R	U- and R-values for overall assembly																			
Surface Temperature Index ¹		T_i	0 = exterior temperature 1 = interior temperature																			
Linear Transmittance		ψ	Incremental increase in transmittance per linear length of column																			
Point Transmittance		χ	Incremental increase in transmittance for knife edge penetration																			
0.90																						
0.80																						
0.70																						
0.60																						
0.50																						
0.40																						
0.30																						
0.20																						
0.10																						
0.00																						

¹Assumptions and limitations for surface temperatures identified in ASHRAE 1365-RP

Nominal (1D) vs. Assembly Performance Indicators

Base Assembly – Wall

Exterior Insulation 1D R-Value (RSI)	R_{1D} ft ² ·hr·°F / Btu (m ² K / W)	R_o ft ² ·hr·°F / Btu (m ² K / W)	U_o Btu/ft ² ·hr ·°F (W/m ² K)
R-42 (7.40)	R-63.3 (11.15)	R-48.3 (8.51)	0.021 (0.12)

Column Linear Transmittance

R_c ft ² ·hr·°F / Btu (m ² K / W)	U_c Btu/ft ² ·hr ·°F (W/m ² K)	ψ Btu/ft hr °F (W/m K)
R-47.7 (8.40)	0.021 (0.12)	0.00070 (0.0012)

Knife Edge Point Transmittance

Exterior Insulation 1D R-Value (RSI)	R ft ² ·hr·°F / Btu (m ² K / W)	U Btu/ft ² ·hr ·°F (W/m ² K)	χ Btu/hr °F (W/K)
R-42 (7.40)	R-32.9 (5.79)	0.030 (0.17)	0.134 (0.071)

Temperature Indices

T_1	0.32	Min T on sheathing beside knife edge, at column
T_2	0.82	Max T on sheathing, at studs, away from knife edge

Detail 5.7.12

Exterior and Interior Insulated 3 5/8" x 1 5/8" Steel Stud (16" o.c.) Wall Assembly with Horizontal Z-girts (24" o.c.) Supporting Metal Cladding and R-12 Batt Insulation in Stud Cavity – Structural Steel Floor Intersection with Thermal Isolator Pad

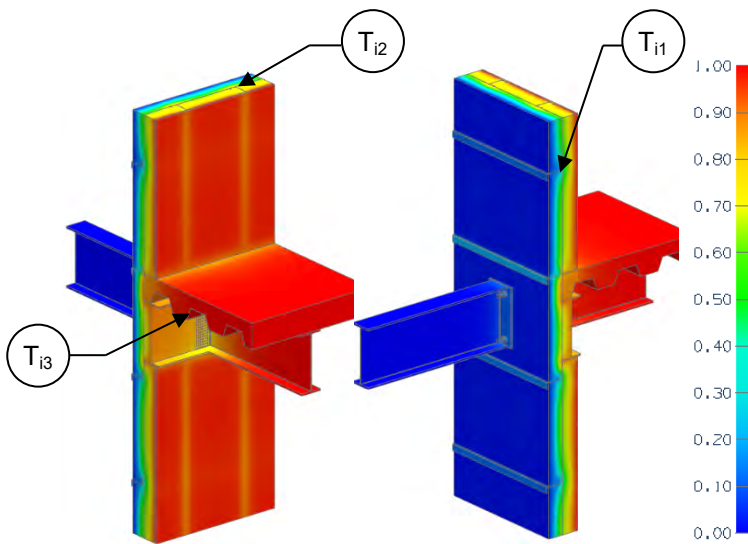

View from Interior

View from Exterior

Thermal Performance Indicators

Assembly 1D (Nominal) R-Value	R_{1D}	R-14.3 (2.52 RSI) + exterior insulation
Transmittance / Resistance without Anomaly	U_o, R_o	"clear wall" U- and R-value without slab or beam
Transmittance / Resistance	U_s, R_s, U_t, R_t	U and R-values for s = steel stud wall + slab t = combined wall + slab + beam
Surface Temperature Index ¹	T_i	0 = exterior temperature 1 = interior temperature
Linear Transmittance	ψ	Incremental increase in transmittance per linear length of floor slab
Point Transmittance	χ	Incremental increase in transmittance for beam penetration

¹Assumptions and limitations for surface temperatures identified in ASHRAE 1365-RP

Nominal (1D) vs. Assembly Performance Indicators

Base Assembly – Wall

Wall Exterior Insulation 1D R-Value (RSI)	R_{1D} ft ² ·hr·°F / Btu (m ² K / W)	R_o ft ² ·hr·°F / Btu (m ² K / W)	U_o Btu/ft ² ·hr·°F (W/m ² K)
R-15 (2.64)	R-29.3 (5.16)	R-18.6 (3.28)	0.054 (0.31)

Beam Point Transmittance

Thermal Isolator Pad	R_t ft ² ·hr·°F / Btu (m ² K / W)	U_t Btu/ft ² ·hr·°F (W/m ² K)	χ Btu/hr °F (W/K)
25 mm pad, stainless steel bolts	R-8.6 (1.51)	0.117 (0.66)	1.11 (0.59)
25 mm pad, steel bolts	R-7.6 (1.33)	0.132 (0.75)	1.44 (0.77)
38 mm pad, stainless steel bolts	R-8.9 (1.56)	0.113 (0.64)	1.02 (0.54)
38 mm pad, steel bolts	R-7.6 (1.34)	0.132 (0.75)	1.43 (0.76)
50 mm pad, stainless steel bolts	R-9.3 (1.64)	0.107 (0.61)	0.91 (0.49)
50 mm pad, steel bolts	R-7.9 (1.38)	0.127 (0.72)	1.34 (0.71)

Slab Linear Transmittance

Wall Exterior Insulation 1D R-Value (RSI)	R_s ft ² ·hr·°F / Btu (m ² K / W)	U_s Btu/ft ² ·hr·°F (W/m ² K)	ψ Btu/ft hr °F (W/m K)
R-15 (2.64)	R-15.6 (2.74)	0.064 (0.36)	0.084 (0.146)

Temperature Indices

	25 mm pad, stainless bolts	25 mm pad, steel bolts	38 mm pad, stainless bolts	38 mm pad, steel bolts	50 mm pad, stainless bolts	50 mm pad, steel bolts	
T_{i1}	0.33	0.33	0.33	0.33	0.33	0.33	Min T on sheathing away from slab, between studs at girts
T_{i2}	0.74	0.74	0.74	0.74	0.74	0.74	Max T on sheathing away from slab, between girts at studs
T_{i3}	0.83	0.79	0.84	0.79	0.85	0.80	Min T on beam exposed to interior air, top flange at I-beam intersection

Detail 5.7.13

Exterior and Interior Insulated 3 5/8" x 1 5/8" Steel Stud (16" o.c.) Wall Assembly with Horizontal Z-girts (24" o.c.) Supporting Metal Cladding and R-12 Batt Insulation in Stud Cavity – Structural Steel Floor Intersection with Isokorb KST System Thermally Broken Beam

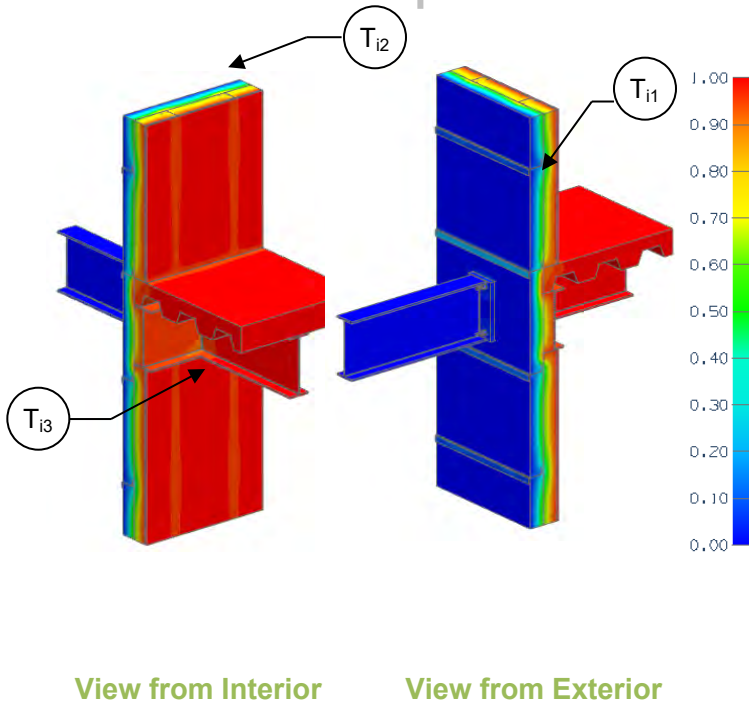

Thermal Performance Indicators

Assembly 1D (Nominal) R-Value	R_{1D}	R-14.3 (2.52 RSI) + exterior insulation
Transmittance / Resistance without Anomaly	U_o, R_o	"clear wall" U- and R-value without slab or beam
Transmittance / Resistance	U_s, R_s, U_t, R_t	U and R-values for s = steel stud wall + slab t = combined wall + slab + beam
Surface Temperature Index ¹	T_i	0 = exterior temperature 1 = interior temperature
Linear Transmittance	ψ	Incremental increase in transmittance per linear length of floor slab
Point Transmittance	χ	Incremental increase in transmittance for beam penetration

¹Assumptions and limitations for surface temperatures identified in ASHRAE 1365-RP

Nominal (1D) vs. Assembly Performance Indicators

Base Assembly – Wall

Wall Exterior Insulation 1D R-Value (RSI)	R_{w1D} ft ² ·hr·°F / Btu (m ² K / W)	R_o ft ² ·hr·°F / Btu (m ² K / W)	U_o Btu/ft ² ·hr·°F (W/m ² K)
R-15 (2.64)	R-29.3 (5.16)	R-18.6 (3.28)	0.054 (0.31)

Slab Transmittance

R_s ft ² ·hr·°F / Btu (m ² K / W)	U_s Btu/ft ² ·hr·°F (W/m ² K)	ψ Btu/ft hr °F (W/m K)
R-15.6 (2.74)	0.064 (0.36)	0.084 (0.146)

Beam Point Transmittance

Wall Exterior Insulation 1D R-Value (RSI)	R_t ft ² ·hr·°F / Btu (m ² K / W)	U_t Btu/ft ² ·hr·°F (W/m ² K)	χ Btu/hr °F (W/K)
R-15 (2.64)	R-11.6 (2.05)	0.086 (0.49)	0.457 (0.243)

Temperature Indices

T_{i1}	0.33	Min T on sheathing away from slab, between studs at girts
T_{i2}	0.78	Max T on sheathing away from slab, between girts at studs
T_{i3}	0.83	Min T on beam exposed to interior air, bottom flange at I-beam intersection

Detail 5.8.1

Exterior and Interior Insulated 3 5/8" x 1 5/8" Steel Stud (16" o.c) Wall Assembly with Horizontal Z-Girts (24" o.c.) Supporting Metal Cladding and R-12 Batt Insulation in Stud Cavity – Interior Wall Intersection

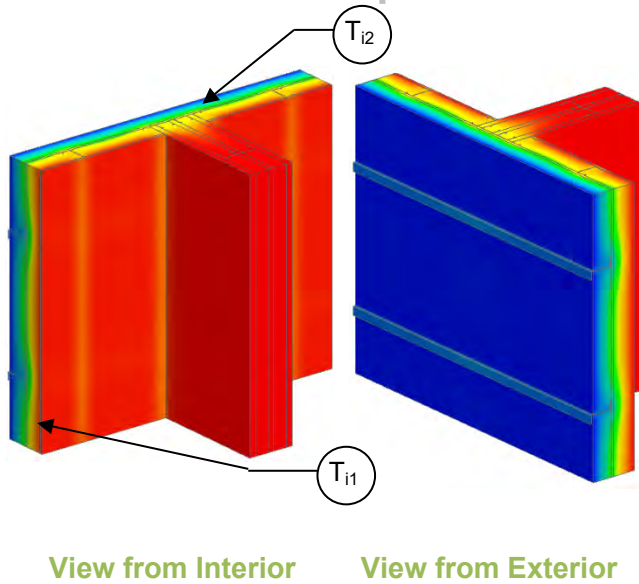

Thermal Performance Indicators

Assembly 1D (Nominal) R-Value	R_{1D}	R-14.2 (2.5 RSI) + exterior insulation
Transmittance / Resistance without Anomaly	U_o, R_o	"clear wall" U- and R-value, without interior wall
Transmittance / Resistance	U, R	U and R-values for the overall assembly
Surface Temperature Index ¹	T_i	0 = exterior temperature 1 = interior temperature
Linear Transmittance	ψ	Incremental increase in transmittance per linear length of inner wall

¹Assumptions and limitations for surface temperatures identified in ASHRAE 1365-RP

Nominal (1D) vs. Assembly Performance Indicators

Exterior Insulation 1D R-Value (RSI)	R_{1D} ft ² ·hr·°F / Btu (m ² K / W)	R_o ft ² ·hr·°F / Btu (m ² K / W)	U_o Btu/ft ² ·hr ·°F (W/m ² K)	R ft ² ·hr·°F / Btu (m ² K / W)	U Btu/ft ² ·hr ·°F (W/m ² K)	ψ Btu/ft hr °F (W/m K)
R-5 (0.88)	R-19.2 (3.38)	R-13.4 (2.36)	0.075 (0.42)	R-12.6 (2.22)	0.079 (0.45)	0.023 (0.039)
R-10 (1.76)	R-24.2 (4.26)	R-16.3 (2.87)	0.061 (0.35)	R-15.6 (2.74)	0.064 (0.37)	0.014 (0.024)
R-15 (2.64)	R-29.2 (5.14)	R-18.5 (3.25)	0.054 (0.31)	R-17.8 (3.14)	0.056 (0.32)	0.010 (0.017)
R-20 (3.52)	R-34.2 (6.02)	R-20.5 (3.61)	0.049 (0.28)	R-19.8 (3.49)	0.050 (0.29)	0.008 (0.014)
R-25 (4.40)	R-39.2 (6.90)	R-22.1 (3.90)	0.045 (0.26)	R-21.4 (3.77)	0.047 (0.27)	0.007 (0.013)

Temperature Indices

	R5	R10	R15	R20	R25	
T_{i1}	0.27	0.29	0.33	0.37	0.39	Min T on sheathing, along girt between studs, away from interior wall intersection
T_{i2}	0.55	0.68	0.73	0.76	0.78	Max T on sheathing, at studs, between z girts, at the acoustic wall intersection

Detail 5.8.2

Exterior Insulated 6" x 1 5/8" Steel Stud (16" o.c.) Wall Assembly with FRP Vertical Brackets and Rail System Supporting Metal Cladding – At-Grade Foundation Wall Intersection

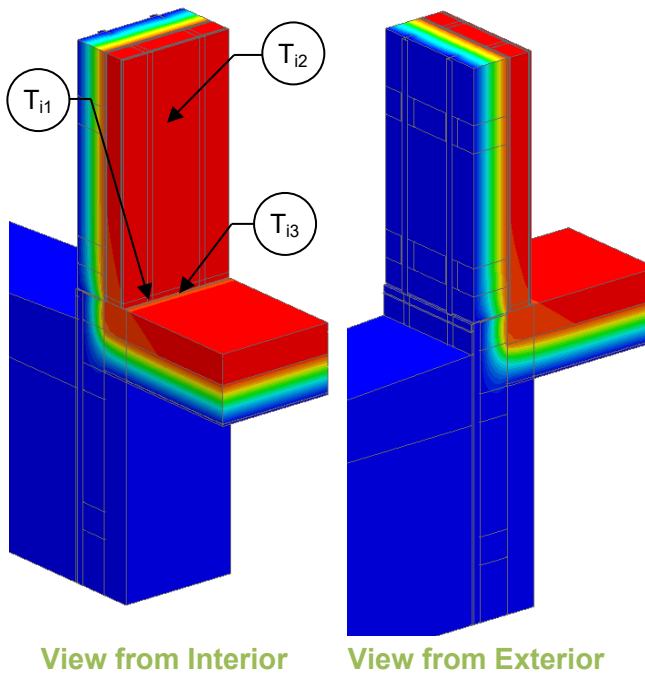

Thermal Performance Indicators

1.00	Assembly 1D (Nominal) R-Value	R_{1D}	R-3.2 (0.56 RSI) + exterior insulation for wall
0.90	Transmittance / Resistance without Anomaly	U_o, R_o	"clear wall" U- and R-value without slab and shelf angle
0.80	Transmittance / Resistance	U, R	U- and R-values for overall assembly
0.70	Surface Temperature Index ¹	T_i	0 = exterior temperature 1 = interior temperature
0.60	Linear Transmittance	ψ	Incremental increase in transmittance per linear length of foundation

¹Assumptions and limitations for surface temperatures identified in ASHRAE 1365-RP

View from Interior

View from Exterior

Scenario

Scenario	
A	Without Thermal Break
B	With Thermal Break

Nominal (1D) vs. Assembly Performance Indicators

Base Assembly – Wall

Exterior Insulation 1D R-Value (RSI)	R_{1D} ft ² ·hr·°F / Btu (m ² K / W)	R_o ft ² ·hr·°F / Btu (m ² K / W)	U_o Btu/ft ² ·hr ·°F (W/m ² K)
R-42.0 (7.40)	R-45.2 (7.96)	R-40.0 (7.04)	0.025 (0.14)

Foundation Linear Transmittance

Scenario	Exterior Insulation 1D R-Value (RSI)	R ft ² ·hr·°F / Btu (m ² K / W)	U Btu/ft ² ·hr ·°F (W/m ² K)	ψ Btu/ft ·hr·°F (W/m K)
A	R-42.0 (7.40)	R-6.5 (1.15)	0.154 (0.87)	0.292 (0.506)
B	R-42.0 (7.40)	R-12.3 (2.17)	0.081 (0.46)	0.059 (0.102)

Temperature Indices

	A	B	
T_{11}	0.74	0.91	Min T on interior sheathing surface at slab intersection, at studs
T_{12}	0.95	0.95	Min T on interior sheathing surface away from slab, between studs at clips
T_{13}	0.80	0.94	Min T on floor, at drywall intersection

Detail 5.8.3

Exterior and Interior Insulated 6" x 1 5/8" Steel Stud (16" o.c.) Wall Assembly with FRP Vertical Brackets and Rail System Supporting Metal Cladding and R19 Batt Insulation in Stud Cavity – At-Grade Foundation Wall Intersection

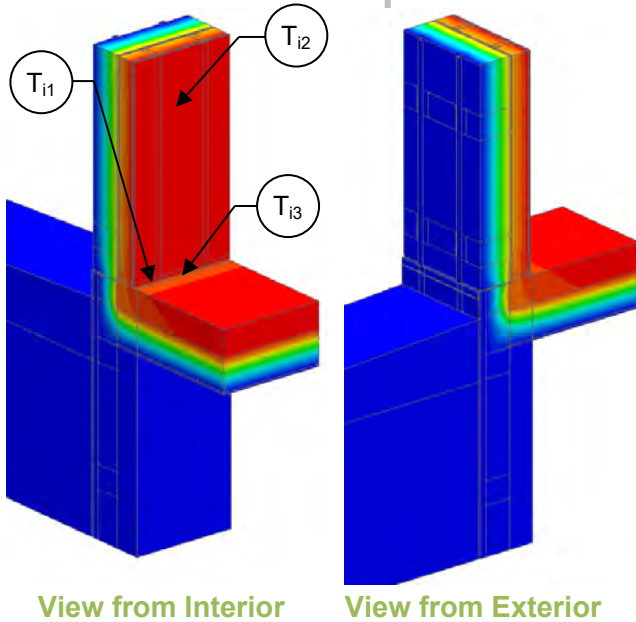

Thermal Performance Indicators

1.00	Assembly 1D (Nominal) R-Value	R_{1D}	R-21.3 (3.75 RSI) + exterior insulation
0.90	Transmittance / Resistance without Anomaly	U_o, R_o	"clear wall" U- and R-value without slab and shelf angle
0.80	Transmittance / Resistance	U, R	U- and R-values for overall assembly
0.70	Surface Temperature Index ¹	T_i	0 = exterior temperature 1 = interior temperature
0.60	Linear Transmittance	ψ	Incremental increase in transmittance per linear length of foundation
0.50			
0.40			
0.30			
0.20			
0.10			
0.00			

¹Assumptions and limitations for surface temperatures identified in ASHRAE 1365-RP

Scenario

Scenario	
A	Without Thermal Break
B	With Thermal Break

Nominal (1D) vs. Assembly Performance Indicators

Base Assembly – Wall

Exterior Insulation 1D R-Value (RSI)	R_{1D} ft ² ·hr·°F / Btu (m ² K / W)	R_o ft ² ·hr·°F / Btu (m ² K / W)	U_o Btu/ft ² ·hr·°F (W/m ² K)
R-42.0 (7.40)	R-63.3 (11.15)	R-48.3 (8.51)	0.021 (0.12)

Foundation Linear Transmittance

Scenario	Exterior Insulation 1D R-Value (RSI)	R ft ² ·hr·°F / Btu (m ² K / W)	U Btu/ft ² ·hr·°F (W/m ² K)	ψ Btu/ft·hr·°F (W/m K)
A	R-42.0 (7.40)	R-7.2 (1.26)	0.140 (0.79)	0.271 (0.468)
B	R-42.0 (7.40)	R-13.6 (2.39)	0.074 (0.42)	0.058 (0.101)

Temperature Indices

	A	B	
T_{i1}	0.65	0.88	Min T on interior sheathing surface at slab intersection, at studs
T_{i2}	0.75	0.75	Min T on interior sheathing surface away from slab, between studs at clips
T_{i3}	0.75	0.92	Min T on floor, at drywall intersection

6.0 Metal Buildings

Detail 6.1.1	B.6.1
Vertical Insulated Metal Panel – Clear Wall with Vertical Connection Joint and Support Girt/Hat Track Backup Wall	
Detail 6.1.2	B.6.2
Vertical Insulated Metal Panel - Metal Stack Joint and Support Girt Back/Hat Track Backup Wall	
Detail 6.1.3	B.6.3
Horizontal Insulated Metal Panel – Clear Wall with Horizontal Connection Joint and Steel Stud Backup Wall	
Detail 6.1.4	B.6.4
Horizontal Insulated Metal Panel – Vertical Gasket Joint with Steel Stud Backup Wall	
Detail 6.1.5	B.6.5
Structural Sheet Steel Wall with Cladding Supported by Notched Z-Bar – Clear Wall	
Detail 6.1.6	B.6.6
Structural Sheet Steel Wall with Cladding Supported by Intermittent Notched Z-Bar – Clear Wall	
Detail 6.1.7	B.6.7
Structural Sheet Steel Wall with Cladding Supported by Thermal Chairs – Clear Wall	
Detail 6.1.8	B.6.8
2 Hour Fire Rated Structural Steel Sheet Wall with Cladding Supported by Notched Z-bar with Ceramic Blanket – Clear Wall	
Detail 6.2.1	B.6.9
Vertical Insulated Metal Panel Corrugated Slab Intersection with I-beam – Open Web Steel Joist and Support Girt/Hat Track Backup Wall	
Detail 6.2.2	B.6.10
Horizontal Insulated Metal Panel Corrugated Slab Intersection with I-beam – Open Web Steel Joist and Steel Stud Backup Wall	
Detail 6.3.1	B.6.11
Vertical Insulated Metal Panel – Window Glazing Transition with Steel Support Framing	
Detail 6.3.2	B.6.12
Horizontal Insulated Metal Panel – Window Glazing Transition with Steel Support Framing	
Detail 6.4.1	B.6.13
Vertical Insulated Metal Panel - Steel Roof Deck with Open Web Steel Joist & Parapet Intersection	

Detail 6.4.2**B.6.14**
Horizontal Insulated Metal Panel - Steel Roof Deck with Open Web Steel Joist & Parapet Intersection

Detail 6.5.1**B.6.15**
Vertical Insulated Metal Panel - Corner Intersection with Post and Support Girt/Hat Track Backup Wall

Detail 6.5.2**B.6.16**
Horizontal Insulated Metal Panel – Corner Intersection with Post and Steel Stud Backup Wall

Detail 6.1.1

Vertical Insulated Metal Panel – Clear Wall with Vertical Connection Joint and Support Girt/Hat Track Backup Wall

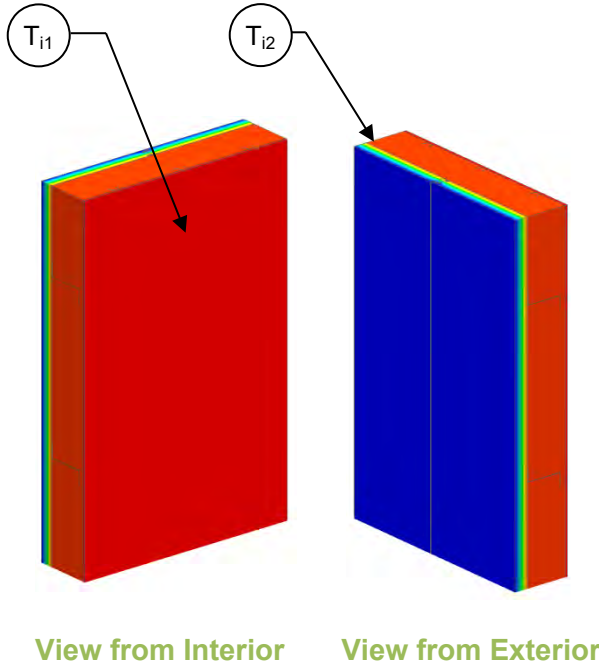

Thermal Performance Indicators

1.00	<table border="1"> <tr> <td>Assembly 1D (Nominal) R-Value</td> <td>R_{1D}</td> <td>Nominal thermal resistance value of panel and backup wall</td> </tr> <tr> <td>Transmittance / Resistance without anomalies</td> <td>U_o, R_o</td> <td>"clear wall" U and R-value</td> </tr> <tr> <td>Surface Temperature Index¹</td> <td>T_i</td> <td>0 = exterior temperature 1 = interior temperature</td> </tr> <tr> <td>Linear Transmittance</td> <td>ψ</td> <td>Incremental increase in transmittance per length of connection joint</td> </tr> </table>	Assembly 1D (Nominal) R-Value	R_{1D}	Nominal thermal resistance value of panel and backup wall	Transmittance / Resistance without anomalies	U_o, R_o	"clear wall" U and R-value	Surface Temperature Index ¹	T_i	0 = exterior temperature 1 = interior temperature	Linear Transmittance	ψ	Incremental increase in transmittance per length of connection joint
Assembly 1D (Nominal) R-Value		R_{1D}	Nominal thermal resistance value of panel and backup wall										
Transmittance / Resistance without anomalies		U_o, R_o	"clear wall" U and R-value										
Surface Temperature Index ¹		T_i	0 = exterior temperature 1 = interior temperature										
Linear Transmittance	ψ	Incremental increase in transmittance per length of connection joint											
0.90													
0.80													
0.70													
0.60													
0.50													
0.40													
0.30													
0.20													
0.10													
0.00													

¹Assumptions and limitations for surface temperatures identified in ASHRAE 1365-RP

²The linear transmittance of the panel joint can be used with the R_{1D} value to find the clear field values for any size of panel

Nominal (1D) vs. Assembly Performance Indicators

Insulated Panel 1D R-Value (RSI)	R_{1D} ft ² ·hr·°F / Btu (m ² K / W)	R_o ft ² ·hr·°F / Btu (m ² K / W)	U_o Btu/ft ² ·hr ·°F (W/m ² K)	ψ^2 Btu/ft ·hr ·°F (W/m K)
R-21.0 (3.70)	R-23.2 (4.09)	R-21.4 (3.80)	0.047 (0.27)	0.013 (0.023)

Temperature Indices

T_{i1}	0.88	Min T on interior panel face, at panel joint and bolts
T_{i2}	0.91	Max T on interior panel face, between joints

Detail 6.1.2

Vertical Insulated Metal Panel - Metal Stack Joint and Support Girt Back/Hat Track Backup Wall

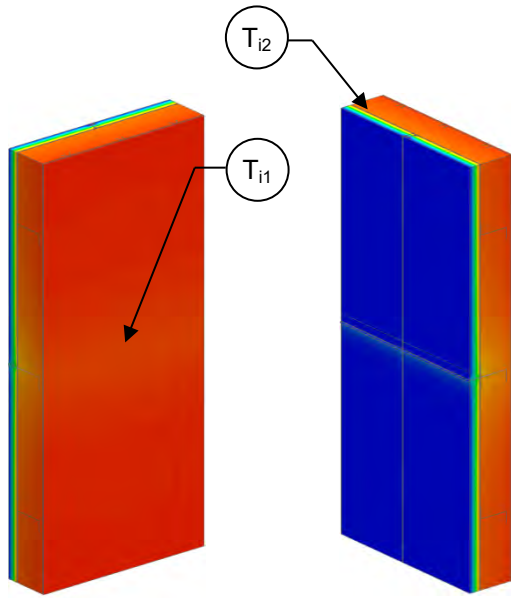

View from Interior

View from Exterior

Thermal Performance Indicators

Assembly 1D (Nominal) R-Value	R_{1D}	Nominal thermal resistance value of panel and backup wall
Transmittance / Resistance without anomalies	U_o, R_o	"clear wall" U and R-value
Transmittance / Resistance	U, R	U- and R-values for overall assembly
Surface Temperature Index ¹	T_i	0 = exterior temperature 1 = interior temperature
Linear Transmittance	ψ	Incremental increase in transmittance per length of stack joint

¹Assumptions and limitations for surface temperatures identified in ASHRAE 1365-RP

²The linear transmittance of the panel joint can be used with the R_{1D} value to find the clear filed values for any size of panel

Nominal (1D) vs. Assembly Performance Indicators

Insulated Panel 1D R-Value (RSI)	R_{1D} ft ² ·hr·°F / Btu (m ² K / W)	R_o ft ² ·hr·°F / Btu (m ² K / W)	U_o Btu/ft ² ·hr·°F (W/m ² K)	R ft ² ·hr·°F / Btu (m ² K / W)	U Btu/ft ² ·hr·°F (W/m ² K)	ψ^2 Btu/ft·hr·°F (W/m K)
R-21.0 (3.70)	R-23.2 (4.09)	R-21.4 (3.80)	0.047 (0.27)	R-15.8 (2.78)	0.063 (0.36)	0.154 (0.266)

Temperature Indices

T_{i1}	0.73	Min T on interior panel face, at bolts and stack joint
T_{i2}	0.91	Max T on interior panel face, between stack joint and panel joints

Detail 6.1.3

Horizontal Insulated Metal Panel – Clear Wall with Horizontal Connection Joint and Steel Stud Backup Wall

Thermal Performance Indicators

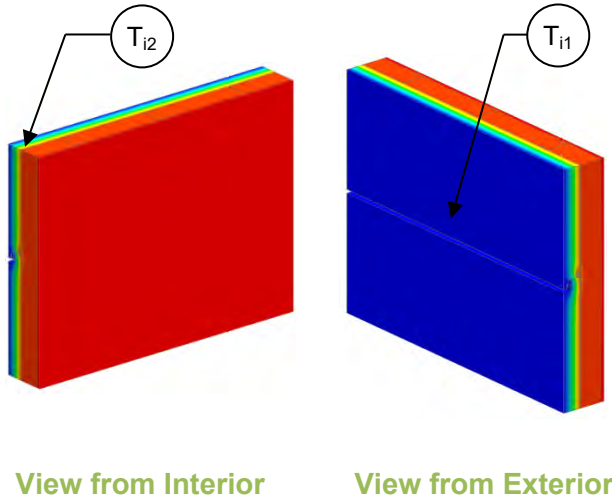

Assembly 1D (Nominal) R-Value	R_{1D}	Nominal thermal resistance value of panel and backup wall
Transmittance / Resistance without anomalies	U_o, R_o	“clear wall” U and R-value
Surface Temperature Index ¹	T_i	0 = exterior temperature 1 = interior temperature
Linear Transmittance	ψ	Incremental increase in transmittance per length of connection joint

¹Assumptions and limitations for surface temperatures identified in ASHRAE 1365-RP

Nominal (1D) vs. Assembly Performance Indicators

Insulated Panel 1D R-Value (RSI)	R_{1D} ft ² ·hr·°F / Btu (m ² K / W)	R_o ft ² ·hr·°F / Btu (m ² K / W)	U_o Btu/ft ² ·hr ·°F (W/m ² K)	ψ Btu/ft ·hr ·°F (W/m K)
R-21.0 (3.70)	R-23.2 (4.09)	R-19.5 (3.43)	0.052 (0.29)	0.025 (0.042)

Temperature Indices

T_{i1}	0.89	Min T on interior panel face, at panel joint and bolts
T_{i2}	0.91	Max T on interior panel face, between joints

Detail 6.1.4

Horizontal Insulated Metal Panel – Vertical Gasket Joint with Steel Stud Backup Wall

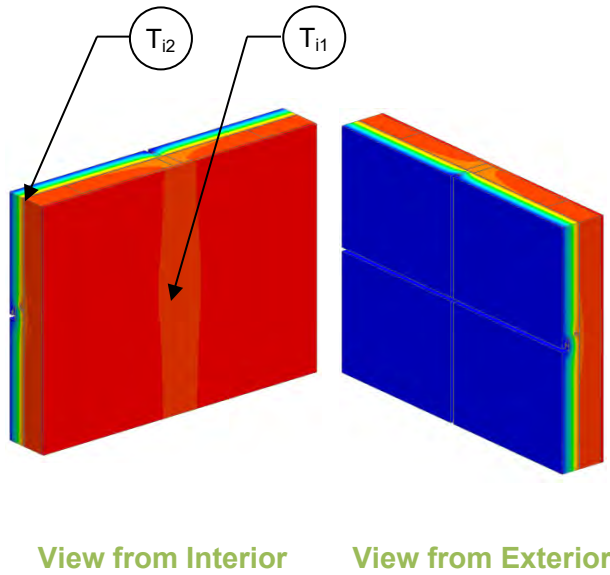

Thermal Performance Indicators

Assembly 1D (Nominal) R-Value	R_{1D}	Nominal thermal resistance value of panel and backup wall
Transmittance / Resistance without anomalies	U_o, R_o	“clear wall” U and R-value
Transmittance / Resistance	U, R	U- and R-values for overall assembly
Surface Temperature Index ¹	T_i	0 = exterior temperature 1 = interior temperature
Linear Transmittance	ψ	Incremental increase in transmittance per length of gasket joint

¹Assumptions and limitations for surface temperatures identified in ASHRAE 1365-RP

Nominal (1D) vs. Assembly Performance Indicators

Insulated Panel 1D R-Value (RSI)	R_{1D} ft ² ·hr·°F / Btu (m ² K / W)	R_o ft ² ·hr·°F / Btu (m ² K / W)	U_o Btu/ft ² ·hr ·°F (W/m ² K)	R ft ² ·hr·°F / Btu (m ² K / W)	U Btu/ft ² ·hr ·°F (W/m ² K)	ψ Btu/ft ·hr ·°F (W/m K)
R-21.0 (3.70)	R-23.2 (4.09)	R-19.5 (3.43)	0.052 (0.29)	R-16.9 (2.97)	0.059 (0.34)	0.032 (0.055)

Temperature Indices

T_{i1}	0.85	Min T on interior panel face, at bolts, at horizontal and vertical joint intersection
T_{i2}	0.91	Max T on interior panel face, between joints

Detail 6.1.5

Structural Sheet Steel Wall with Cladding Supported by Notched Z-Bar – Clear Wall

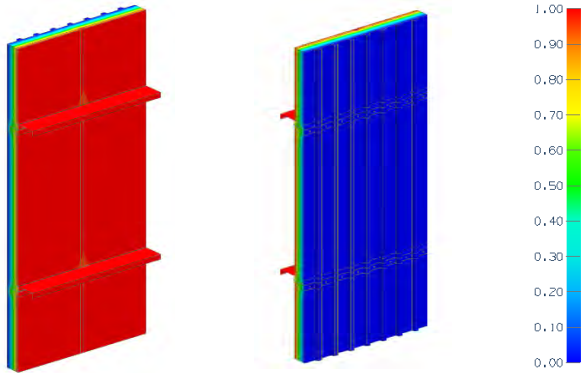

Thermal Performance Indicators

Assembly 1D (Nominal) R-Value	R_{1D}	R-0.9 (0.15 RSI) + exterior insulation
Transmittance / Resistance	U_o , R_o	“Clear wall” U- and R-value

View from Interior View from Exterior

Nominal (1D) vs. Assembly Performance Indicators

Baseline System

Vertical Spacing of Z-bar	Exterior Insulation 1D R-Value (RSI)	R_{1D} ft ² ·hr·°F / Btu (m ² K / W)	R_o ft ² ·hr·°F / Btu (m ² K / W)	U_o Btu/ft ² ·hr ·°F (W/m ² K)
48	R-25 (4.44)	R-25.9 (4.59)	R-21.8 (3.84)	0.046 (0.260)
60	R-25 (4.44)	R-25.9 (4.59)	R-22.5 (3.96)	0.044 (0.253)
72	R-25 (4.44)	R-25.9 (4.59)	R-23.0 (4.05)	0.044 (0.247)

Sensitivity Analysis – Impact of Steel Liner and Notched Z-Bar Thickness for Vertical Spacing of Z-Bar at 60” o.c.

Steel Thickness	Exterior Insulation 1D R-Value (RSI)	R_{1D} ft ² ·hr·°F / Btu (m ² K / W)	Liner		Z-Bar	
			R_o ft ² ·hr·°F / Btu (m ² K / W)	U_o Btu/ft ² ·hr ·°F (W/m ² K)	R_o ft ² ·hr·°F / Btu (m ² K / W)	U_o Btu/ft ² ·hr ·°F (W/m ² K)
24 Ga	R-25 (4.44)	R-25.9 (4.59)	R-22.5 (3.96)	0.044 (0.253)	R-22.9 (4.03)	0.045 (0.256)
18 Ga	R-25 (4.44)	R-25.9 (4.59)	R-22.4 (3.95)	0.045 (0.253)	R-22.5 (3.96)	0.044 (0.253)
12 Ga	R-25 (4.44)	R-25.9 (4.59)	-	-	R-22.2 (3.91)	0.044 (0.248)

Sensitivity Analysis – Impact of PVC Coating on Notched Z-Bar with Vertical Spacing of Z-Bar at 60” o.c

PVC Coating Thickness on Thermal Chairs and Outer Rails (mils)	Exterior Insulation 1D R-Value (RSI)	R_{1D} ft ² ·hr·°F / Btu (m ² K / W)	R_o ft ² ·hr·°F / Btu (m ² K / W)	U_o Btu/ft ² ·hr ·°F (W/m ² K)
0 Top, 0 Bottom	R-25 (4.44)	R-25.9 (4.59)	R-22.5 (3.96)	0.044 (0.253)
8 Top, 4 Bottom	R-25 (4.44)	R-25.9 (4.59)	R-22.7 (3.99)	0.044 (0.251)

Sensitivity Analysis – Impact of Thermal Tape at Notched Z-Bar with Vertical Spacing of Z-Bar at 60” o.c

Tape Thickness (in)	Tape R-Value (RSI)	Exterior Insulation 1D R-Value (RSI)	R_{1D} ft ² ·hr·°F / Btu (m ² K / W)	R_o ft ² ·hr·°F / Btu (m ² K / W)	U_o Btu/ft ² ·hr ·°F (W/m ² K)
0	R-0 (0.00)	R-25 (4.44)	R-25.9 (4.59)	R-21.4 (3.78)	0.047 (0.265)
1/8	R-1 (0.23)	R-25 (4.44)	R-25.9 (4.59)	R-22.5 (3.96)	0.044 (0.253)
1/4	R-3 (0.45)	R-25 (4.44)	R-25.9 (4.59)	R-22.8 (4.01)	0.044 (0.249)

Sensitivity Analysis – Impact of Insulation Type for Notched Z-Bar with Vertical Spacing of Z-Bar at 60” o.c

Insulation Thickness (in)	R-4.2/inch insulation			R-5/inch insulation			R-6/inch insulation		
	Exterior Insulation 1D R-Value (RSI)	R_o ft ² ·hr·°F / Btu (m ² K / W)	U_o Btu/ft ² ·hr ·°F (W/m ² K)	Exterior Insulation 1D R-Value (RSI)	R_o ft ² ·hr·°F / Btu (m ² K / W)	U_o Btu/ft ² ·hr ·°F (W/m ² K)	Exterior Insulation 1D R-Value (RSI)	R_o ft ² ·hr·°F / Btu (m ² K / W)	U_o Btu/ft ² ·hr ·°F (W/m ² K)
6	R-25 (4.44)	R-22.5 (3.96)	0.044 (0.253)	R-30 (5.28)	R-26.0 (4.57)	0.039 (0.219)	R-36 (6.34)	R-30.1 (5.31)	0.033 (0.188)
7	R-29 (5.18)	R-25.7 (4.52)	0.039 (0.221)	R-35 (6.16)	R-29.6 (5.21)	0.034 (0.192)	R-42 (7.40)	R-34.2 (6.03)	0.029 (0.166)
8	R-34 (5.92)	R-28.4 (5.01)	0.035 (0.200)	R-40 (7.04)	R-32.7 (5.76)	0.031 (0.173)	R-48 (8.45)	R-37.8 (6.65)	0.026 (0.150)

Detail 6.1.6

Structural Sheet Steel Wall with Cladding Supported by Intermittent Notched Z-Bar – Clear Wall

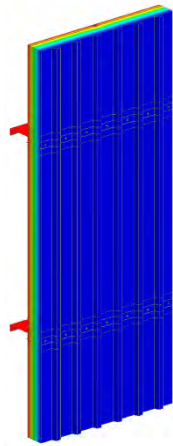
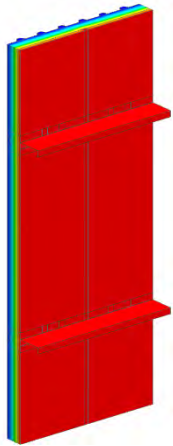

Thermal Performance Indicators

Assembly 1D (Nominal) R-Value	R_{1D}	R-0.9 (0.15 RSI) + exterior insulation
Transmittance / Resistance	U_o , R_o	“Clear wall” U- and R-value

View from Interior

View from Exterior

Nominal (1D) vs. Assembly Performance Indicators

Vertical Spacing of Z-bar	Exterior Insulation 1D R-Value (RSI)	R_{1D} ft ² ·hr·°F / Btu (m ² K / W)	R_o ft ² ·hr·°F / Btu (m ² K / W)	U_o Btu/ft ² ·hr·°F (W/m ² K)
Continuous z-bar with Thermal Block	R-25 (4.44)	R-25.9 (4.59)	R-22.5 (3.96)	0.044 (0.253)
Intermittent z-bar without Thermal Block	R-25 (4.44)	R-25.9 (4.59)	R-21.1 (3.72)	0.047 (0.269)

Detail 6.1.7

Structural Sheet Steel Wall with Cladding Supported by Thermal Chairs – Clear Wall

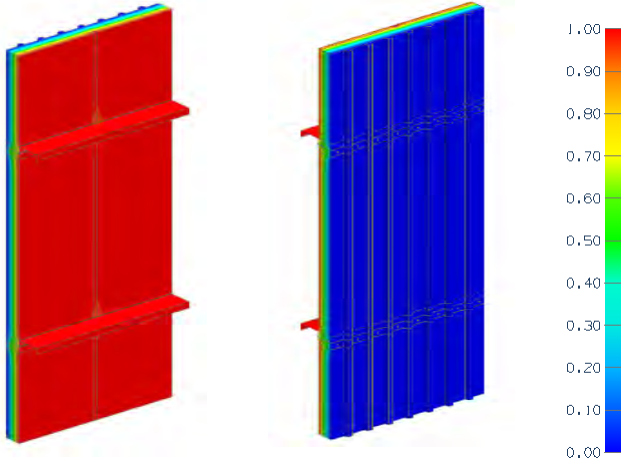

View from Interior View from Exterior

Thermal Performance Indicators

Assembly 1D (Nominal) R-Value	R_{1D}	R-0.9 (0.15 RSI) + exterior insulation
Transmittance / Resistance	U_o , R_o	“Clear wall” U- and R-value

Nominal (1D) vs. Assembly Performance Indicators

Baseline System

Vertical Spacing of Z-Bar (in)	Horizontal Thermal Chair Spacing (in)	Exterior Insulation 1D R-Value (RSI)	R_{1D} ft ² ·hr·°F / Btu (m ² K / W)	R_o ft ² ·hr·°F / Btu (m ² K / W)	U_o Btu/ft ² ·hr ·°F (W/m ² K)
60	24	R-25 (4.44)	R-25.9 (4.59)	R-24.3 (4.28)	0.041 (0.233)
60	36	R-25 (4.44)	R-25.9 (4.59)	R-24.4 (4.30)	0.041 (0.233)
60	48	R-25 (4.44)	R-25.9 (4.59)	R-24.8 (4.36)	0.040 (0.229)

Sensitivity Analysis – Impact of Steel Chair and Notched U-Channel Thickness for Horizontal Spacing at 24” o.c. and Vertical Spacing of Thermal Chair at 60” o.c.

Steel Thickness	Exterior Insulation 1D R-Value (RSI)	Thermal Chair R_{1D} ft ² ·hr·°F / Btu (m ² K / W)	Thermal Chair		U-Channel	
			R_o ft ² ·hr·°F / Btu (m ² K / W)	U_o Btu/ft ² ·hr ·°F (W/m ² K)	R_o ft ² ·hr·°F / Btu (m ² K / W)	U_o Btu/ft ² ·hr ·°F (W/m ² K)
24 Ga	R-25 (4.44)	R-25.9 (4.59)	R-24.4 (4.30)	0.041 (0.233)	R-24.3 (4.28)	0.041 (0.233)
18 Ga	R-25 (4.44)	R-25.9 (4.59)	R-24.3 (4.28)	0.041 (0.233)	R-22.5 (3.96)	0.041 (0.233)
14 Ga	R-25 (4.44)	R-25.9 (4.59)	R-24.2 (4.27)	0.041 (0.234)	R-22.2 (3.91)	0.041 (0.234)

Detail 6.1.8

2 Hour Fire Rated Structural Steel Sheet Wall with Cladding Supported by Notched Z-bar with Ceramic Blanket – Clear Wall

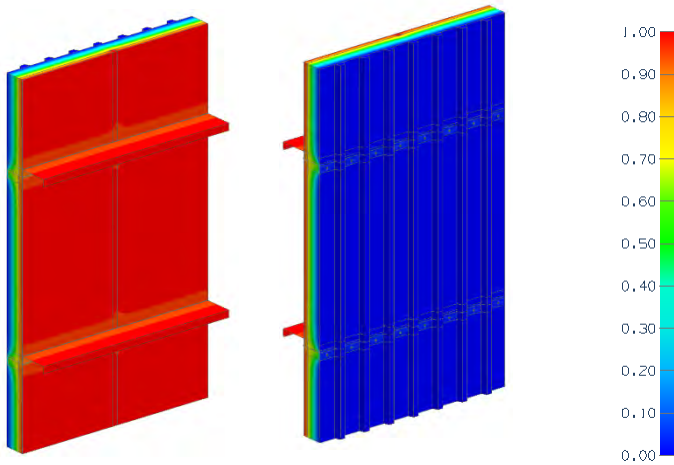

Thermal Performance Indicators

Assembly 1D (Nominal) R-Value	R_{1D}	R-0.9 (0.15 RSI) + exterior insulation
Transmittance / Resistance	U_o , R_o	“Clear wall” U- and R-value

View from Interior View from Exterior

Nominal (1D) vs. Assembly Performance Indicators

Vertical Spacing of Z-bar	Exterior Insulation 1D R-Value (RSI)	R_{1D} ft ² ·hr·°F / Btu (m ² K / W)	R_o ft ² ·hr·°F / Btu (m ² K / W)	U_o Btu/ft ² ·hr ·°F (W/m ² K)
60	R-25 (4.44)	R-25.9 (4.59)	R-14.2 (2.51)	0.070 (0.400)

Detail 6.2.1

Vertical Insulated Metal Panel Corrugated Slab Intersection with I-beam – Open Web Steel Joist and Support Girt/Hat Track Backup Wall

Thermal Performance Indicators

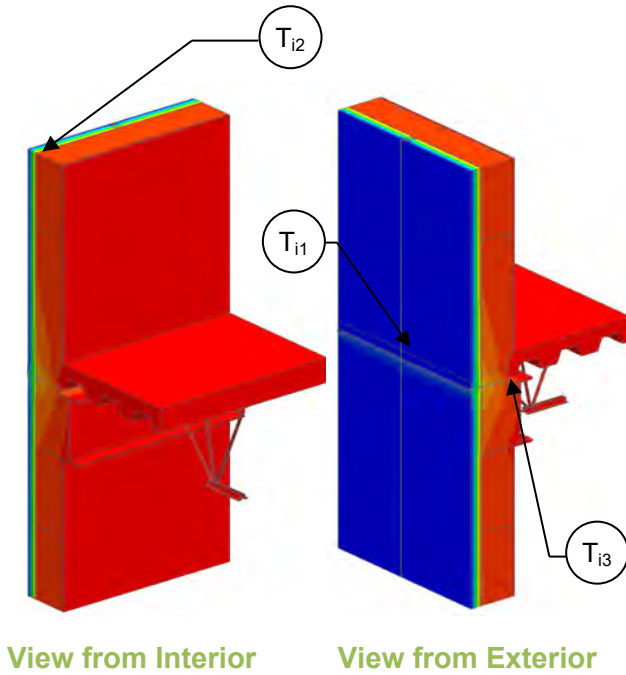

Assembly 1D (Nominal) R-Value	R_{1D}	Nominal thermal resistance value of panel and backup wall
Transmittance / Resistance without Anomaly	U_o, R_o	“clear field” U and R-value
Transmittance / Resistance	U, R	U- and R-values for overall assembly
Surface Temperature Index ¹	T_i	0 = exterior temperature 1 = interior temperature
Linear Transmittance	ψ	Incremental increase in transmittance per length of slab

¹Assumptions and limitations for surface temperatures identified in ASHRAE 1365-RP

Nominal (1D) vs. Assembly Performance Indicators

Insulated Panel 1D R-Value (RSI)	R_{1D} ft ² ·hr·°F / Btu (m ² K / W)	R_o ft ² ·hr·°F / Btu (m ² K / W)	U_o Btu/ft ² ·hr·°F (W/m ² K)	R ft ² ·hr·°F / Btu (m ² K / W)	U Btu/ft ² ·hr·°F (W/m ² K)	ψ Btu/ft·hr·°F (W/m K)
R-21.0 (3.70)	R-23.2 (4.09)	R-21.4 (3.80)	0.047 (0.27)	R-14.9 (2.63)	0.067 (0.38)	0.187 (0.323)

Temperature Indices

T_{i1}	0.73	Min T on interior panel face, at bolts and stack joint
T_{i2}	0.91	Max T on interior panel face, away from slab and joints
T_{i3}	0.90	Min T on interior surfaces, on corrugated slab ceiling

Detail 6.2.2

Horizontal Insulated Metal Panel Corrugated Slab Intersection with I-beam – Open Web Steel Joist and Steel Stud Backup Wall

Thermal Performance Indicators

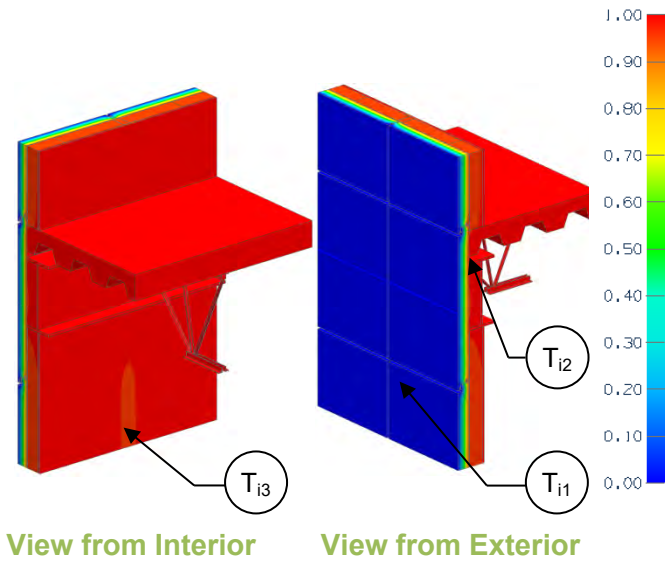

Assembly 1D (Nominal) R-Value	R_{1D}	Nominal thermal resistance value of panel and backup wall
Transmittance / Resistance without anomalies	U_o, R_o	“clear wall” U and R-value
Transmittance / Resistance	U, R	U- and R-values for overall assembly
Surface Temperature Index ¹	T_i	0 = exterior temperature 1 = interior temperature
Linear Transmittance	ψ	Incremental increase in transmittance per length of slab

¹Assumptions and limitations for surface temperatures identified in ASHRAE 1365-RP

Nominal (1D) vs. Assembly Performance Indicators

Insulated Panel 1D R-Value (RSI)	R_{1D} ft ² ·hr·°F / Btu (m ² K / W)	R_o ft ² ·hr·°F / Btu (m ² K / W)	U_o Btu/ft ² ·hr·°F (W/m ² K)	R ft ² ·hr·°F / Btu (m ² K / W)	U Btu/ft ² ·hr·°F (W/m ² K)	ψ Btu/ft·hr·°F (W/m K)
R-21.0 (3.70)	R-23.2 (4.09)	R-19.5 (3.43)	0.052 (0.29)	R-16.3 (2.87)	0.061 (0.35)	0.016 (0.027)

Temperature Indices

T_{i1}	0.87	Min T on interior panel face, at bolts and joint intersection, away from slab
T_{i2}	0.97	Max T on interior panel face, at I-Beam
T_{i3}	0.95	Min T on interior surfaces, at steel studs, away from I-Beam

Detail 6.3.1

Vertical Insulated Metal Panel – Window Glazing Transition with Steel Support Framing

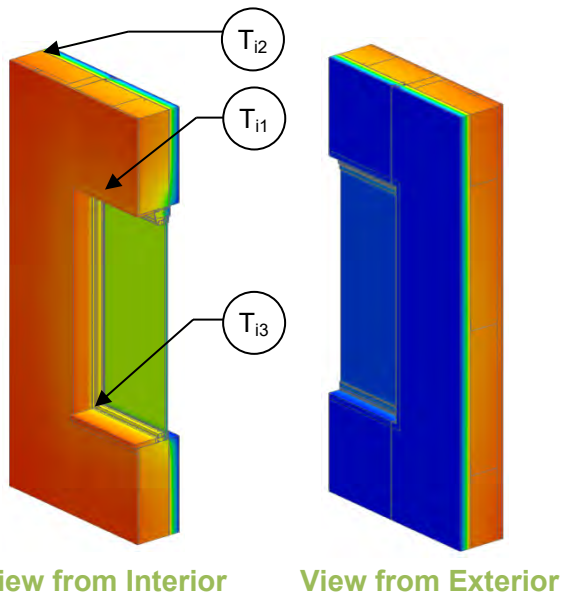

Thermal Performance Indicators

0.00	Assembly 1D (Nominal) R-Value	R_{1D}	Nominal thermal resistance value of wall
0.10	Transmittance / Resistance without Anomaly	U_o, R_o	“clear wall” U and R-value
0.20	Transmittance / Resistance	U, R	U- and R-values for overall assembly
0.30	Surface Temperature Index ¹	T_i	0 = exterior temperature 1 = interior temperature
0.40	Linear Transmittance	ψ	Incremental increase in transmittance per length of glazing transition
0.50			
0.60			
0.70			
0.80			
0.90			
1.00			

¹Assumptions and limitations for surface temperatures identified in ASHRAE 1365-RP

Nominal (1D) vs. Assembly Performance Indicators

Base Assembly – Wall

Insulated Panel 1D R-Value (RSI)	R_{1D} ft ² ·hr·°F / Btu (m ² K / W)	R_o ft ² ·hr·°F / Btu (m ² K / W)	U_o Btu/ft ² ·hr ·°F (W/m ² K)
R-21.0 (3.70)	R-23.2 (4.09)	R-21.4 (3.80)	0.047 (0.27)

Window Transition Transmittance

R ft ² ·hr·°F / Btu (m ² K / W)	U Btu/ft ² ·hr ·°F (W/m ² K)	ψ Btu/ft ·hr ·°F (W/m K)
R-7.1 (1.25)	0.414 (0.80)	0.292 (0.505)

Temperature Indices

T_{i1}	0.41	Min T on interior panel face, at top track
T_{i2}	0.91	Max T on interior panel face, away from window, between joints
T_{i3}	0.54	Min T on frame, at jamb and sill intersection

Detail 6.3.2

Horizontal Insulated Metal Panel – Window Glazing Transition with Steel Support Framing

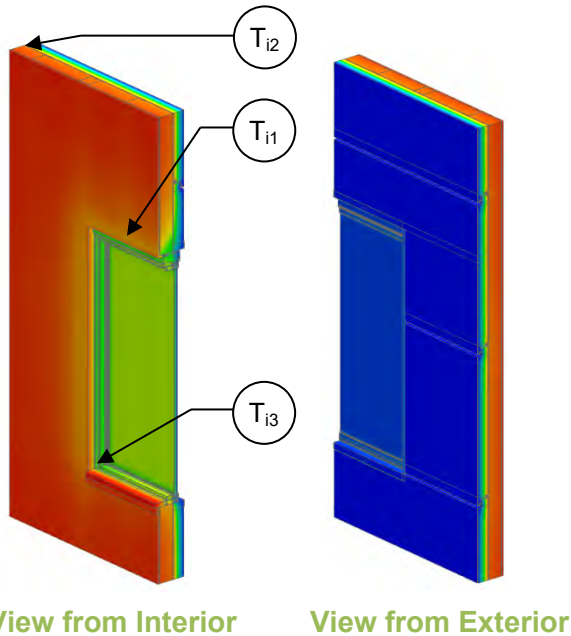

Thermal Performance Indicators

Assembly 1D (Nominal) R-Value	R_{1D}	Nominal thermal resistance value of wall
Transmittance / Resistance without Anomaly	U_o, R_o	“clear wall” U and R-value
Transmittance / Resistance	U, R	U- and R-values for overall assembly
Surface Temperature Index ¹	T_i	0 = exterior temperature 1 = interior temperature
Linear Transmittance	ψ	Incremental increase in transmittance per length of glazing transition

¹Assumptions and limitations for surface temperatures identified in ASHRAE 1365-RP

Nominal (1D) vs. Assembly Performance Indicators

Base Assembly – Wall

Insulated Panel 1D R-Value (RSI)	R_{1D} ft ² ·hr·°F / Btu (m ² K / W)	R_o ft ² ·hr·°F / Btu (m ² K / W)	U_o Btu/ft ² ·hr·°F (W/m ² K)
R-21.0 (3.70)	R-23.2 (4.09)	R-19.5 (3.43)	0.052 (0.29)

Window Transition Transmittance

R ft ² ·hr·°F / Btu (m ² K / W)	U Btu/ft ² ·hr·°F (W/m ² K)	ψ Btu/ft·hr·°F (W/m K)
R-7.5 (1.32)	0.133 (0.75)	0.263 (0.454)

Temperature Indices

T_{i1}	0.45	Min T on interior panel face, at top track
T_{i2}	0.91	Max T on interior panel face, away from window, between joints
T_{i3}	0.54	Min T on frame, at jamb and sill intersection

Detail 6.4.1

Vertical Insulated Metal Panel - Steel Roof Deck with Open Web Steel Joist & Parapet Intersection

Thermal Performance Indicators

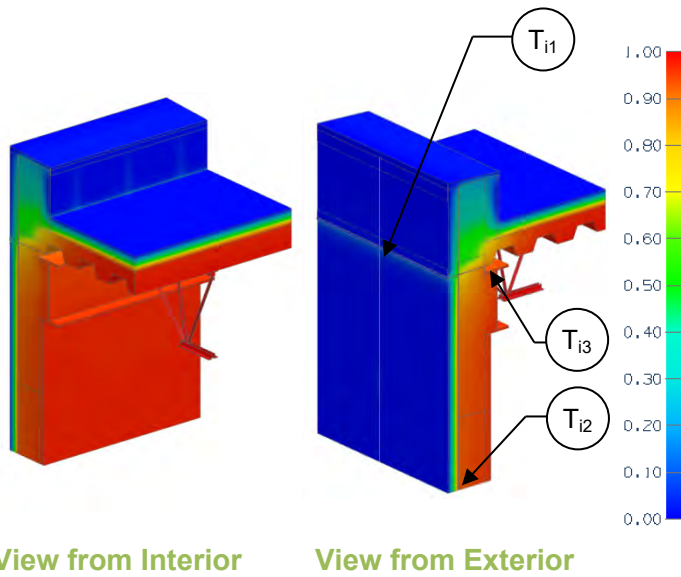

Assembly 1D (Nominal) R-Value	R_{1D}	R-2.2 (0.39 RSI) + exterior insulation
Transmittance / Resistance without anomalies	U_r, R_r, U_w, R_w	“clear field” U- and R-values for: r = insulated roof w = steel stud wall assembly with horizontal z girts
Transmittance / Resistance	U, R	U and R-values for the overall assembly
Surface Temperature Index ¹	T_i	0 = exterior temperature 1 = interior temperature
Linear Transmittance	ψ	Incremental increase in transmittance per length of parapet

¹Assumptions and limitations for surface temperatures identified in ASHRAE 1365-RP

Nominal (1D) vs. Assembly Performance Indicators

Base Assembly – Wall

Insulated Panel 1D R-Value (RSI)	R_{1D} ft ² ·hr·°F / Btu (m ² K / W)	R_w ft ² ·hr·°F / Btu (m ² K / W)	U_w Btu/ft ² ·hr ·°F (W/m ² K)
R-21.0 (3.70)	R-23.2 (4.09)	R-21.4 (3.80)	0.047 (0.27)

Base Assembly - Roof

Roof Exterior Insulation 1D R-Value (RSI)	R_r ft ² ·hr·°F / Btu (m ² K / W)	U_r Btu/ft ² ·hr ·°F (W/m ² K)
R-20 (3.52)	R-21.9 (3.86)	0.046 (0.26)

Parapet Transmittance

Insulated Panel 1D R-Value (RSI)	R ft ² ·hr·°F / Btu (m ² K / W)	U Btu/ft ² ·hr ·°F (W/m ² K)	ψ Btu/ft ·hr ·°F (W/m K)
R-21.0 (3.70)	R-9.5 (1.68)	0.105 (0.60)	0.283 (0.489)

Temperature Indices

T_{i1}	0.71	Min T on interior panel face, at bolts, underneath support girt and semi-rigid insulation
T_{i2}	0.91	Max T on interior panel face, away from roof and joints
T_{i3}	0.84	Min T on interior surfaces, at roof and joist

Detail 6.4.2

Horizontal Insulated Metal Panel - Steel Roof Deck with Open Web Steel Joist & Parapet Intersection

Thermal Performance Indicators

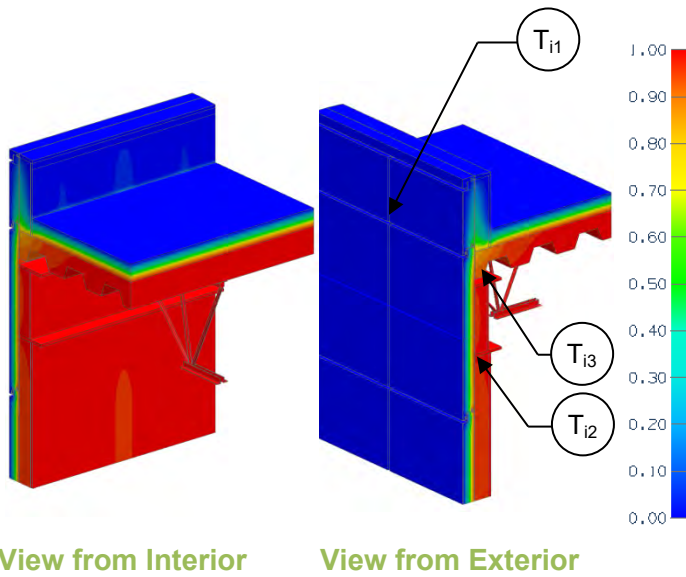

Assembly 1D (Nominal) R-Value	R_{1Dw}	R-2.2 (0.39 RSI) + exterior insulation
Transmittance / Resistance without Anomaly	U_r , R_r , U_w , R_w	“clear field” U- and R-values for: r = insulated roof w = steel stud wall assembly with horizontal z girts
Transmittance / Resistance	U, R	U and R-values for the overall assembly
Surface Temperature Index ¹	T_i	0 = exterior temperature 1 = interior temperature
Linear Transmittance	ψ	Incremental increase in transmittance per length of parapet

¹Assumptions and limitations for surface temperatures identified in ASHRAE 1365-RP

Nominal (1D) vs. Assembly Performance Indicators

Base Assembly – Wall

Insulated Panel 1D R-Value (RSI)	R_{1D} ft ² ·hr·°F / Btu (m ² K / W)	R_w ft ² ·hr·°F / Btu (m ² K / W)	U_w Btu/ft ² ·hr ·°F (W/m ² K)
R-21.0 (3.70)	R-23.2 (4.09)	R-19.5 (3.43)	0.052 (0.29)

Base Assembly - Roof

Roof Exterior Insulation 1D R-Value (RSI)	R_r ft ² ·hr·°F / Btu (m ² K / W)	U_r Btu/ft ² ·hr ·°F (W/m ² K)
R-20 (3.52)	R-21.9 (3.86)	0.046 (0.26)

Parapet Transmittance

Insulated Panel 1D R-Value (RSI)	R ft ² ·hr·°F / Btu (m ² K / W)	U Btu/ft ² ·hr ·°F (W/m ² K)	ψ Btu/ft ·hr ·°F (W/m K)
R-21.0 (3.70)	R-11.6 (2.04)	0.087 (0.49)	0.237 (0.410)

Temperature Indices

T_{i1}	0.52	Min T on interior panel face, at bolts and slab
T_{i2}	0.95	Max T on interior panel face, at I-Beam
T_{i3}	0.87	Min T on interior surfaces, on corrugated roof, near wall

Detail 6.5.1

Vertical Insulated Metal Panel - Corner Intersection with Post and Support Girt/Hat Track Backup Wall

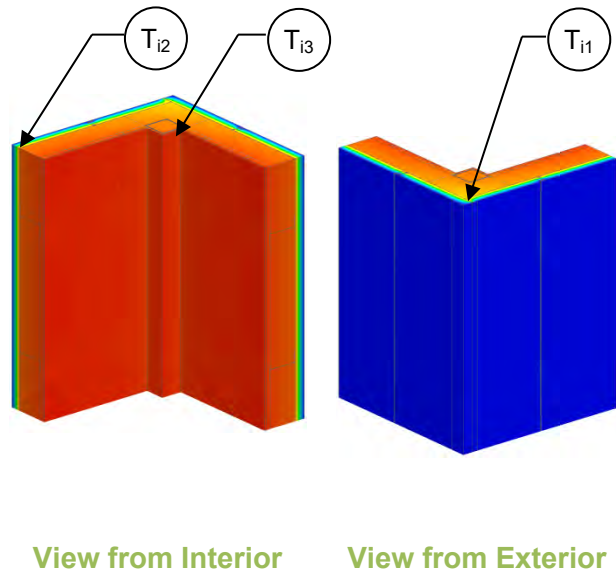

Thermal Performance Indicators

Assembly 1D (Nominal) R-Value	R_{1D}	R-2.2 (0.39 RSI) + exterior insulation
Transmittance / Resistance without Anomaly	U_o, R_o	“clear wall” U- and R-value, without corner
Transmittance / Resistance	U, R	U- and R-values for overall assembly
Surface Temperature Index ¹	T_i	0 = exterior temperature 1 = interior temperature
Linear Transmittance	ψ	Incremental increase in transmittance per length of corner

¹Assumptions and limitations for surface temperatures identified in ASHRAE 1365-RP

Nominal (1D) vs. Assembly Performance Indicators

Insulated Panel 1D R-Value (RSI)	R_{1D} ft ² ·hr·°F / Btu (m ² K / W)	R_o ft ² ·hr·°F / Btu (m ² K / W)	U_o Btu/ft ² ·hr ·°F (W/m ² K)	R ft ² ·hr·°F / Btu (m ² K / W)	U Btu/ft ² ·hr ·°F (W/m ² K)	ψ Btu/ft ·hr ·°F (W/m K)
R-21.0 (3.70)	R-23.2 (4.09)	R-21.4 (3.80)	0.047 (0.27)	R-16.3 (2.88)	0.061 (0.35)	0.090 (0.156)

Temperature Indices

T_{i1}	0.78	Min T on interior panel face, at corner, away from support girts
T_{i2}	0.91	Max T on interior panel face, at support girts. Away from corner
T_{i3}	0.93	Min T on interior surfaces, at interior drywall corner

Detail 6.5.2

Horizontal Insulated Metal Panel – Corner Intersection with Post and Steel Stud Backup Wall

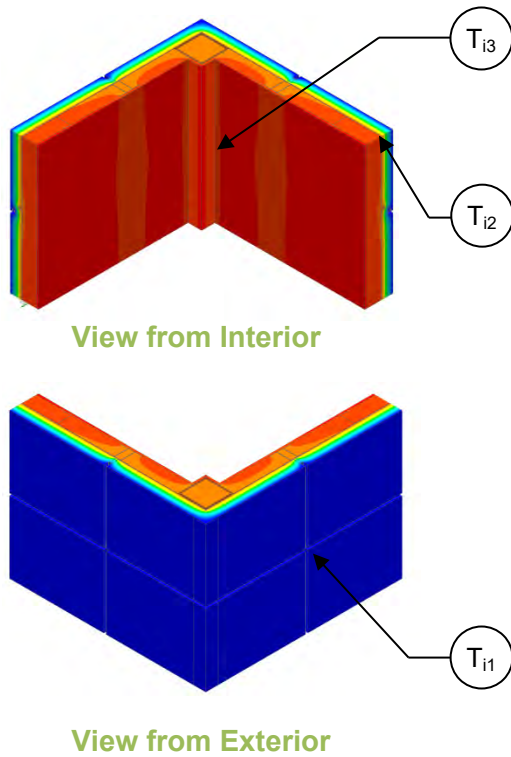

Thermal Performance Indicators

Assembly 1D (Nominal) R-Value	R_{1D}	R-2.2 (0.39 RSI) + exterior insulation
Transmittance / Resistance without Anomaly	U_o, R_o	“clear field” U and R-value, without corner
Transmittance / Resistance	U, R	U- and R-values for overall assembly
Surface Temperature Index ¹	T_i	0 = exterior temperature 1 = interior temperature
Linear Transmittance	ψ	Incremental increase in transmittance per length of corner

¹Assumptions and limitations for surface temperatures identified in ASHRAE 1365-RP

Nominal (1D) vs. Assembly Performance Indicators

Insulated Panel 1D R-Value (RSI)	R_{1D} ft ² ·hr·°F / Btu (m ² K / W)	R_o ft ² ·hr·°F / Btu (m ² K / W)	U_o Btu/ft ² ·hr ·°F (W/m ² K)	R ft ² ·hr·°F / Btu (m ² K / W)	U Btu/ft ² ·hr ·°F (W/m ² K)	ψ Btu/ft ·hr ·°F (W/m K)
R-21.0 (3.70)	R-23.2 (4.09)	R-19.5 (3.43)	0.052 (0.29)	R-15.2 (2.68)	0.066 (0.37)	0.037 (0.064)

Temperature Indices

T_{i1}	0.85	Min T on interior panel face, at bolts, at joint intersection
T_{i2}	0.91	Max T on interior panel face, between joints away from corner
T_{i3}	0.92	Min T on interior surfaces, at inner drywall corner

7.0 Concrete and Mass Masonry Construction

Detail 7.1.1	B.7.1
Exterior Insulated Concrete Drained EIFS Wall Assembly - Clear Wall	
Detail 7.1.2	B.7.2
Exterior Insulated Concrete Mass Wall Assembly with 1/4 inch (6 mm) Stainless Steel Brackets Supporting 1-1/4" Stone Panels – Clear Wall	
Detail 7.1.3	B.7.3
Exterior Insulated Concrete Block Wall with Thermally Broken ISO Clip System with Horizontal Sub-Girt Supporting Cladding – Clear Wall	
Detail 7.1.4	B.7.4
Exterior Insulated Concrete Assembly with Nvelope – NV1 Clip System Supporting Cladding – Clear Wall	
Detail 7.1.5	B.7.5
Exterior Insulated Concrete Block Wall Assembly with Nvelope – NV1 Clip System Supporting Cladding – Clear Wall	
Detail 7.1.6	B.7.6
Exterior Insulated Concrete Mass Wall Assembly with Hohmann & Barnard Masonry Zinc 2-Seal Anchor Supporting Brick Veneer – Clear Wall	
Detail 7.1.7	B.7.7
Exterior Insulated Concrete Mass Wall Assembly with Hohmann & Barnard Masonry Stainless Steel 2-Seal Thermal Wing Nut Anchor Supporting Brick Veneer – Clear Wall	
Detail 7.1.8	B.7.8
Precast Sandwich Panel Wall Assembly with Concrete Panel Joints – Clear Wall	
Detail 7.1.9	B.7.9
Precast Sandwich Panel Wall Assembly with Tigerloc Thermally Broken Panel Joints – Clear Wall	
Detail 7.1.10	B.7.10
Precast Concrete Sandwich Panel Wall Assembly with FRP Connectors – Clear Wall Detail	
Detail 7.1.11	B.7.11
Exterior Insulated Concrete Block Wall with Armadillo FRR Horizontal Z-Girts Supporting Cladding – Clear Wall	
Detail 7.1.12	B.7.12
Exterior Insulated Concrete Block Wall with Vertical Clips Supporting Cladding – Clear Wall	
Detail 7.1.13	B.7.13
Exterior Insulated Concrete Block Wall Assembly with Brick Ties Supporting Brick Veneer – Clear Wall	
Detail 7.1.14	B.7.14

Interior Insulated Concrete Mass Wall with 1 5/8" Steel Stud (16" o.c.) Supporting Interior Finish Wall Assembly – Clear Wall	
Detail 7.1.15	B.7.15
Precast Sandwich Panel Wall Assembly with Steel Connectors and 3 5/8" x 1 5/8" Steel Stud (16" o.c.) – Clear Wall	
Detail 7.1.16	B.7.16
Exterior Insulated Concrete Mass Wall Assembly with 3/8 inch (9.5 mm Stainless Steel Brackets Supporting 3" Stone Panels – Clear Wall	
Detail 7.1.17	B.7.17
Exterior Insulated Concrete Block Wall Assembly with SOPREMA SOPRA-XPS 20 and ACS-S Thermal Clip (16" o.c. Horizontal) Supporting Metal Cladding - Clear Wall	
Detail 7.1.18	B.7.18
Exterior Insulated Concrete Block Wall Assembly with SOPREMA SOPRA-XPS 20 and ACS-S Thermal Clip (24" o.c. Horizontal) Supporting Metal Cladding - Clear Wall	
Detail 7.1.19	B.7.19
Exterior Insulated Concrete Block Wall Assembly with SOPREMA SOPRA-SPF 202 and ACS-S Thermal Clip (16" o.c. Horizontal) Supporting Metal Cladding - Clear Wall	
Detail 7.1.20	B.7.20
Exterior Insulated Concrete Block Wall Assembly with SOPREMA SOPRA-SPF 202 and ACS-S Thermal Clip (24" o.c. Horizontal) Supporting Metal Cladding - Clear Wall	
Detail 7.1.21	B.7.21
Exterior Insulated Concrete Block Wall Assembly with SOPREMA SOPRA-ISO V ALU and ACS-S Thermal Clip (16" o.c. Horizontal) Supporting Metal Cladding - Clear Wall	
Detail 7.1.22	B.7.22
Exterior Insulated Concrete Block Wall Assembly with SOPREMA SOPRA-ISO V ALU and ACS-S Thermal Clip (24" o.c. Horizontal) Supporting Metal Cladding - Clear Wall	
Detail 7.1.23	B.7.23
Exterior Insulated Concrete Block Wall Assembly with Mineral Wool and ACS-S Thermal Clip (16" o.c. Horizontal) Supporting Metal Cladding - Clear Wall	
Detail 7.1.24	B.7.24
Exterior Insulated Concrete Block Wall Assembly with Mineral Wool and ACS-S Thermal Clip (24" o.c. Horizontal) Supporting Metal Cladding - Clear Wall	
Detail 7.1.25	B.7.25

Exterior Insulated Concrete Block Wall Assembly with Protected SOPREMA SOPRA-ISO V ALU and ACS-S Thermal Clip (16" o.c. Horizontal) Supporting Metal Cladding - Clear Wall	
Detail 7.1.26	B.7.26
Exterior Insulated Concrete Block Wall Assembly with Protected SOPREMA SOPRA-ISO V ALU and ACS-S Thermal Clip (24" o.c. Horizontal) Supporting Metal Cladding - Clear Wall	
Detail 7.1.27	B.7.27
Exterior Insulated Concrete Mass Wall with 1 5/8" x 1 5/8" Steel Stud (16" o.c.) and Thermally Isolated Vertical Brackets and Rail System (24" o.c.) Supporting Metal Cladding – Clear Wall	
Detail 7.2.1	B.7.28
Exterior Insulated Concrete Drained EIFS Wall Assembly – Intermediate Floor Intersection	
Detail 7.2.2	B.7.29
Interior Insulated Concrete Mass Wall with 1 5/8" Steel Stud (16" o.c.) Supporting Interior Finish – Non-Insulated Interior Wall and Non-insulated Intermediate Floor Intersection	
Detail 7.2.3	B.7.30
Interior Insulated Concrete Mass Wall with 1 5/8" Steel Stud (16" o.c.) Supporting Interior Finish – Insulated Interior Wall and Non-insulated Intermediate Floor Intersection	
Detail 7.2.4	B.7.31
Interior Insulated Concrete Mass Wall with 3 5/8" x 1 5/8" Steel Studs (16" o.c.) Supporting Interior Finish – Interior Insulated Wall and Non-Insulated Partition Wall Intersection	
Detail 7.2.5	B.7.32
Interior Insulated Concrete Mass Wall with 1 5/8" x 1 5/8" Steel Studs (16" o.c.) Supporting Interior Finish – Continuous Concrete Intermediate Floor Intersection	
Detail 7.2.6	B.7.33
Precast Wall Assembly with 3 5/8" x 1 5/8" Steel Stud (16" o.c.) and Insulation in Stud Cavity – Intermediate Floor Intersection	
Detail 7.2.7	B.7.34
Precast Wall Assembly with 3 5/8" x 1 5/8" Steel Stud (16" o.c.) and Rigid Insulation Outboard of Studs – Intermediate Floor Intersection	
Detail 7.2.8	B.7.35
Precast Sandwich Panel Wall Assembly with 3 5/8" x 1 5/8" Steel Stud (16" o.c.) – Intermediate Floor Intersection	
Detail 7.2.9	B.7.36
Precast Sandwich Panel Wall Assembly with Concrete at Panel Perimeter and Steel Connectors at 24" o.c. – Intermediate Floor Intersection	

Detail 7.2.10	B.7.37
Precast Sandwich Panel Wall Assembly with Steel Connectors at 16" o.c. – Intermediate Floor Intersection	
Detail 7.2.11	B.7.38
Precast Sandwich Panel Wall Assembly with Steel Connectors at 36" o.c. – Intermediate Floor Intersection	
Detail 7.2.12	B.7.39
Precast Sandwich Panel Wall Assembly with Steel Connectors at 48" o.c. – Intermediate Floor Intersection	
Detail 7.2.13	B.7.40
Precast Sandwich Panel Wall Assembly with Fiber-Reinforced Composite Connectors at 16" o.c. – Intermediate Floor Intersection B.7.	
Detail 7.2.14	B.7.41
Exterior Insulated Concrete Block Wall Assembly with Shelf Angle & Brick Ties Supporting Brick Veneer – Intermediate Floor Intersection	
Detail 7.2.15	B.7.42
Exterior Insulated Concrete Block Wall Assembly with Stand-Off Shelf Angle & Brick Ties Supporting Brick Veneer – Intermediate Floor Intersection	
Detail 7.2.16	B.7.43
Exterior Insulated Concrete Block Wall Assembly with Masonry Ties Supporting Brick Veneer – Intermediate Floor Intersection at Balcony	
Detail 7.2.17	B.7.44
Exterior Insulated Concrete Block Wall Assembly with Masonry Ties Supporting Brick Veneer – Angle Supported Slab & Intermediate Floor Intersection	
Detail 7.2.18	B.7.45
Exterior Insulated Concrete Block Wall Assembly with Masonry Ties Supporting Brick Veneer – Intermediate Floor Intersection at Balcony	
Detail 7.2.19	B.7.46
Exterior Insulated Concrete Block Wall Assembly with Thermally Broken Shelf Angle & Brick Ties Supporting Brick Veneer – Slab Intersection	
Detail 7.2.20	B.7.47
Interior Insulated Concrete Mass Wall with 1 5/8" x 1 5/8" Steel Studs (16" o.c.) Supporting Interior Finish – Isokorb Rutherma DF Thermally Broken Concrete Intermediate Floor Intersection	
Detail 7.2.21	B.7.48
Highly Insulated Precast Concrete Sandwich Panel Wall Assembly – Intermediate Floor Intersection with Inner Wythe Supported by Concrete Floor	
Detail 7.2.22	B.7.49

Owens Corning Exterior Insulated Concrete Block Wall Assembly with Shelf Angle and Heckmann Pos-I-Tie Veneer Anchoring System Supporting Brick Veneer – Intermediate Floor Intersection	
Detail 7.2.23	B.7.50
Owens Corning Exterior Insulated Concrete Block Wall Assembly with Stainless Steel Stand-off Shelf Angle and Heckmann Pos-I-Tie Veneer Anchoring System Supporting Brick Veneer – Intermediate Floor Intersection	
Detail 7.2.24	B.7.51
Exterior Insulated Concrete Mass Wall with 1 5/8" x 1 5/8" Steel Stud (16" o.c.) and Thermally Isolated Vertical Brackets and Rail System (24" o.c.) Supporting Metal Cladding – Intermediate Floor Intersection	
Detail 7.2.25	B.7.52
Insulated Precast Concrete Sandwich Panel Wall Assembly – Intermediate Floor Intersection with Inner Wythe Supported by Concrete Floor	
Detail 7.3.1	B.7.54
Exterior Insulated Concrete Drained EIFS Wall Assembly – Window and Intermediate Floor Intersection	
Detail 7.3.2	B.7.55
Interior Insulated Concrete Mass Wall with 1 5/8" x 1 5/8" Steel Studs (16" o.c.) Supporting Interior Finish – Window & Intermediate Floor Intersection	
Detail 7.3.3	B.7.56
Interior Insulated Concrete Mass Wall with 1 5/8" x 1 5/8" Steel Studs (16" o.c.) Supporting Interior Finish – Window & Projected Slab Intersection	
Detail 7.3.4	B.7.57
Precast Sandwich Panel Wall Assembly with Concrete at Panel Perimeter and Steel Connectors (24" o.c.) - Window Intersection	
Detail 7.3.5	B.7.58
Precast Sandwich Panel Wall Assembly with Steel Connectors at 24" (o.c.), and 3 5/8" Steel Stud (16" o.c.) – Window Intersection	
Detail 7.3.6	B.7.59
Exterior Insulated Concrete Drained EIFS Wall Assembly – Window with Aerogel and Intermediate Floor Intersection	
Detail 7.3.7	B.7.60
Interior Insulated Concrete Block or Concrete Wall Assembly with Brick Cladding - Window Intersection	
Detail 7.3.8	B.7.61
Interior Insulated Concrete Block or Concrete Wall Assembly with Brick Cladding - Window Intersection Aligned with Insulation	
Detail 7.3.9	B.7.62

Interior Insulated Concrete Mass Wall with 1 5/8" x 1 5/8" Steel Studs (16" o.c.) Supporting Interior Finish – Window & Projected Slab Intersection with Plywood and Insulation Liner	
Detail 7.3.10	B.7.63
Interior Insulated Concrete Mass Wall with 1 5/8" x 1 5/8" Steel Studs (16" o.c.) Supporting Interior Finish – Window & Projected Slab Intersection with Wall Insulation Wrapped into Opening	
Detail 7.3.11	B.7.64
Interior Insulated Concrete Mass Wall with 1 5/8" x 1 5/8" Steel Studs (16" o.c.) Supporting Interior Finish – Window & Projected Slab Intersection – Plywood Liner and Glazing Aligned with Wall Insulation	
Detail 7.3.12	B.7.65
Exterior Insulated Concrete Mass Wall with 1 5/8" x 1 5/8" Steel Stud (16" o.c.) and Thermally Isolated Vertical Brackets and Rail System (24" o.c.) Supporting Metal Cladding – Triple Glazed Aluminum Window & Intermediate Floor Intersection with Window Thermal Break Positioned in Concrete Opening	
Detail 7.3.13	B.7.66
Exterior Insulated Concrete Mass Wall with 1 5/8" x 1 5/8" Steel Stud (16" o.c.) and Thermally Isolated Vertical Brackets and Rail System (24" o.c.) Supporting Metal Cladding – Triple Glazed Aluminum Curtain Wall & Intermediate Floor Intersection with Window Thermal Break Positioned in the Exterior Insulation	
Detail 7.3.14	B.7.67
Owens Corning Exterior Insulated Concrete Block Wall Assembly with Heckmann Pos-I-Tie Veneer Anchoring System Supporting Brick Veneer with Insulation Interrupted at Window Perimeter – Double Glazed Aluminum Window and Intermediate Floor Intersection	
Detail 7.3.15	B.7.68
Owens Corning Exterior Insulated Concrete Block Wall Assembly with Heckmann Pos-I-Tie Veneer Anchoring System Supporting Brick Veneer with Reduced Insulation at Jambes – Triple Glazed Aluminum High Performance Window and Intermediate Floor Intersection	
Detail 7.3.16	B.7.69
Interior Insulated Multi-Wythe Brick Masonry Wall with 1 5/8" x 1 5/8" Steel Studs (16" o.c.) Supporting Interior Finish – Wood Window Intersection with Un- Insulated Window Perimeter	
Detail 7.3.17	B.7.70
Interior Insulated Multi-Wythe Brick Masonry Wall with 1 5/8" x 1 5/8" Steel Studs (16" o.c.) Supporting Interior Finish – Aluminum Window Intersection with Un- insulated window Perimeter	
Detail 7.3.18	B.7.71

Interior Insulated Multi-Wythe Brick Masonry Wall with 1 5/8" x 1 5/8" Steel Studs (16" o.c.) Supporting Interior Finish– Aluminum Window Intersection with Insulation at Window Perimeter	
Detail 7.3.19	B.7.72
Interior Insulated Brick Masonry Wall with 1 5/8" x 1 5/8" Steel Studs (16" o.c.) Supporting Interior Finish – Aluminum Window Intersection with Aerogel Blanket at Window Perimeter	
Detail 7.3.20	B.7.73
Precast Sandwich Panel Wall Assembly with PVC at Panel Perimeter, Steel Connectors at 24" (o.c.), and 3 5/8" Steel Stud (16" o.c.) – Window Intersection	
Detail 7.3.21	B.7.74
Precast Sandwich Panel Wall Assembly with Wood at Panel Perimeter, Steel Connectors at 24" (o.c.), and 3 5/8" Steel Stud (16" o.c.) – Window Intersection	
Detail 7.3.22	B.7.75
Precast Sandwich Panel Wall Assembly with Gypsum Board at Panel Perimeter, Steel Connectors at 24" (o.c.), and 3 5/8" Steel Stud (16" o.c.) – Window Intersection	
Detail 7.3.23	B.7.76
Precast Sandwich Panel Wall Assembly, Steel Connectors at 24" (o.c.), and 3 5/8" Steel Stud (16" o.c.) – Window Intersection	
Detail 7.4.1	B.7.77
Exterior Insulated Concrete Drained EIFS Wall Assembly – Conventional Curtain Wall Transition	
Detail 7.4.2	B.7.78
Precast Sandwich Panel Wall Assembly with 3 5/8" Steel Stud (16" o.c.) – Curtain Wall Spandrel Transition	
Detail 7.4.3	B.7.79
Interior Insulated Concrete Mass Wall – Conventional Curtain Wall Transition	
Detail 7.4.4	B.7.80
Interior Insulated Concrete Mass Wall – Thermally Broken Curtain Wall Transition	
Detail 7.4.5	B.7.81
Precast Sandwich Panel Wall Assembly – Tigerloc Thermally Broken Curtain Wall Transition	
Detail 7.4.6	B.7.82
Highly Insulated Precast Concrete Sandwich Panel Wall Assembly – High Performance Aluminum Window Sill Detail	
Detail 7.4.7	B.7.83
Highly Insulated Precast Concrete Sandwich Panel Wall Assembly – High Performance Aluminum Window Head Detail	

Detail 7.5.1	B.7.84
Exterior Insulated Concrete Drained EIFS Wall Assembly – Concrete Parapet & Slab Intersection	
Detail 7.5.2	B.7.85
Exterior Insulated Concrete Drained EIFS Wall Assembly – Insulated Concrete Parapet & Slab Intersection	
Detail 7.5.3	B.7.86
Interior Insulated Concrete Mass Wall with 1 5/8" Steel Stud (16" o.c) Supporting Interior Finish – Concrete Parapet & Roof Intersection	
Detail 7.5.4	B.7.87
Precast Sandwich Panel Wall Assembly with 3 5/8" Steel Stud (16" o.c.) – Steel Roof Deck with Open Web Steel Joist & Parapet Intersection	
Detail 7.5.5	B.7.88
Precast Sandwich Panel – Steel Roof Deck with Open Web Steel Joist & Parapet Intersection	
Detail 7.5.6	B.7.89
Precast Wall Assembly with 3 5/8" x 1 5/8" Steel Stud (16" o.c) and Rigid Insulation Outboard of Studs – Parapet & Roof Intersection	
Detail 7.5.7	B.7.90
Precast Wall Assembly with 3 5/8" x 1 5/8" Steel Stud (16" o.c) and Rigid Insulation Outboard of Studs – Parapet & Roof Intersection with Thermal Break under Parapet Stud Cavity and At Anchors	
Detail 7.5.8	B.7.91
Exterior Insulated Concrete Block Wall Assembly with Masonry Ties Supporting Brick Veneer – Parapet & Roof Intersection	
Detail 7.5.9	B.7.92
Precast Sandwich Panel – Steel Roof Deck with Open Web Steel Joist & Paraloc Thermally Broken Parapet Intersection	
Detail 7.5.10	B.7.93
Highly Insulated Precast Concrete Sandwich Panel Wall Assembly – Roof to Wall Intersection with Wood-Framed Parapet	
Detail 7.5.11	B.7.94
Owens Corning Exterior Insulated Concrete Block Wall Assembly with Heckmann Pos-I-Tie Veneer Anchoring System Supporting Brick Veneer – Roof to Wall Intersection with Uninsulated Parapet	
Detail 7.5.12	B.7.95
Owens Corning Exterior Insulated Concrete Block Wall Assembly with Heckmann Pos-I-Tie Veneer Anchoring System Supporting Brick Veneer – Roof to Wall Intersection with Insulation Wrapped Around Parapet	
Detail 7.5.13	B.7.96

Window Wall System – Double Glazed Insulated Frame at Concrete Precast Panel Parapet & Roof Intersection	
Detail 7.5.14	B.7.97
Window Wall System – Double Glazed Insulated Frame at Isokorb AXTI Thermally Broken Concrete Parapet & Roof Intersection	
Detail 7.5.15	B.7.98
Window Wall System – Triple Glazed Insulated Frame at Concrete Precast Panel Parapet & Roof Intersection	
Detail 7.5.16	B.7.99
Window Wall System – Triple Glazed Insulated Frame at Isokorb AXTI Thermally Broken Concrete Parapet & Roof Intersection	
Detail 7.6.1	B.7.100
Exterior Insulated Concrete Drained EIFS Wall Assembly – Corner Intersection	
Detail 7.6.2	B.7.101
Highly Insulated Precast Concrete Sandwich Panel Wall Assembly – Outside Corner	
Detail 7.7.1	B.7.102
Interior Insulated Concrete Mass Wall with 3 5/8" x 1 5/8" Steel Studs (16" o.c.) Supporting Interior Finish – Intermediate Floor Intersection above Parking Garage	
Detail 7.7.2	B.7.103
Insulated Concrete Floor Slab – Concrete Column Intersection	
Detail 7.7.3	B.7.104
Precast Sandwich Panel with 3 5/8" Steel Stud (16" o.c.) – Concrete Slab and Foundation Intersection	
Detail 7.7.4	B.7.105
Precast Sandwich Panel with 3 5/8" Steel Stud (16" o.c.) - Concrete Slab and Foundation Wall Intersection	
Detail 7.7.5	B.7.106
Precast Sandwich Panel with 3 5/8" Steel Stud (16" o.c.) – Thermally Broken Concrete Slab and Foundation Intersection	
Detail 7.7.6	B.7.107
Insulated Slab on Grade – Steel Column	
Detail 7.7.7	B.7.108
Insulated Slab on Grade – Armatherm 500 Thermal Break under Column	
Detail 7.7.8	B.7.109
Highly Insulated Precast Concrete Sandwich Panel Wall Assembly – Base of Wall at Foundation with Insulation Skirt	
Detail 7.7.9	B.7.110

Owens Corning Exterior Insulated Concrete Block Wall Assembly with Steel Shelf Angle and Heckmann Pos-I-Tie Veneer Anchoring System Supporting Brick Veneer and Insulation Below Floor – Slab on Grade and Foundation Intersection

Detail 7.7.10B.7.111

Owens Corning Exterior Insulated Concrete Block Wall Assembly with Stainless Steel Shelf Angle and Heckmann Pos-I-Tie Veneer Anchoring System Supporting Brick Veneer and Insulation Below Floor – Slab on Grade and Foundation Intersection

Detail 7.8.1B.7.112

Precast Sandwich Panel Wall Assembly – Emloc Thermally Broken Embedment Detail

Detail 7.1.1

Exterior Insulated Concrete Drained EIFS Wall Assembly - Clear Wall

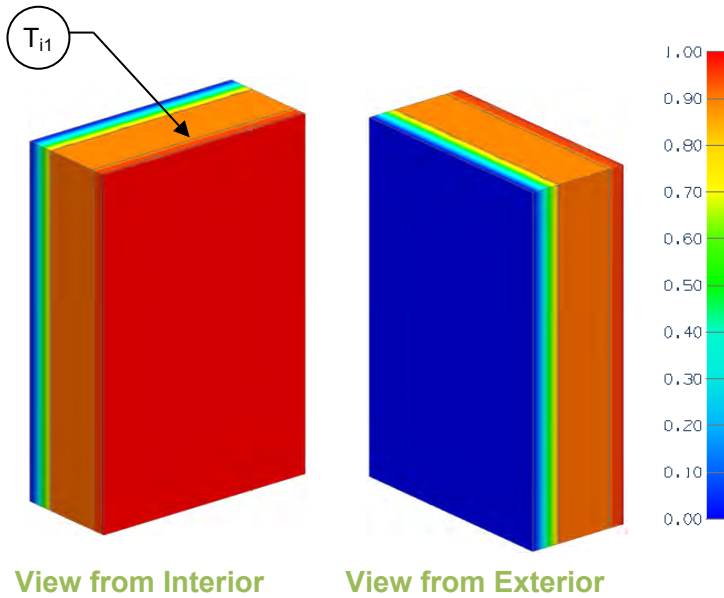

Thermal Performance Indicators

Assembly 1D (Nominal) R-Value	R_{1D}	R-3.0 (0.53 RSI) + exterior insulation
Transmittance / Resistance	U_o, R_o	"clear wall" U- and R-value
Surface Temperature Index ¹	T_i	0 = exterior temperature 1 = interior temperature

¹Assumptions and limitations for surface temperatures identified in ASHRAE 1365-RP

Nominal (1D) vs. Assembly Performance Indicators

Exterior Insulation 1D R-Value (RSI)	R_{1D} ft ² ·hr·°F / Btu (m ² K / W)	R_o ft ² ·hr·°F / Btu (m ² K / W)	U_o Btu/ft ² ·hr·°F (W/m ² K)
R-15 (2.64)	R-18.0 (3.17)	R-17.6 (3.10)	0.057 (0.32)

Temperature Indices

T_{i1}	0.89	Consistent temperature along interior concrete surface
----------	------	--

Detail 7.1.2

Exterior Insulated Concrete Mass Wall Assembly with 1/4 inch (6 mm) Stainless Steel Brackets Supporting 1-1/4" Stone Panels – Clear Wall

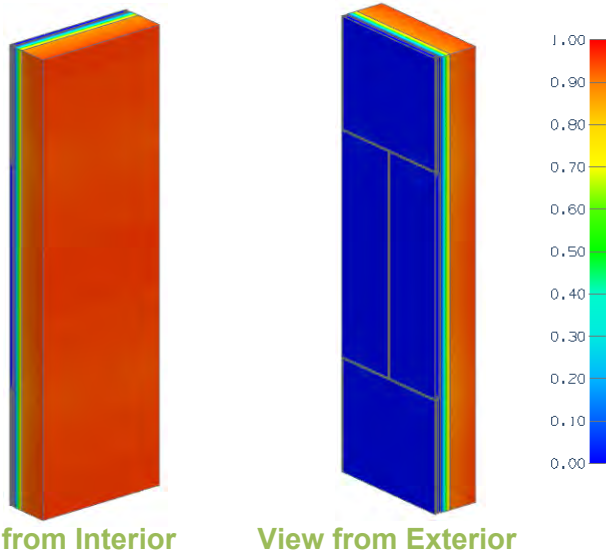

Thermal Performance Indicators

Assembly 1D (Nominal) R-Value	R_{1D}	R-1.9 (0.34 RSI) + insulation
Transmittance / Resistance	U_o, R_o	“clear field” U- and R-value
Point Transmittance	χ	Incremental increase in transmittance for one bracket

Nominal (1D) vs. Assembly Performance Indicators

Exterior Insulation 1D R-Value (RSI)	R_{1D} ft ² ·hr·°F / Btu (m ² K / W)	R_o ft ² ·hr·°F / Btu (m ² K / W)	U_o Btu/ft ² ·hr ·°F (W/m ² K)	χ Btu/hr·°F (W/K)
R-5 (0.88)	R-6.9 (1.22)	R-6.6 (1.16)	0.151 (0.86)	0.062 (0.033)
R-15 (2.64)	R-16.9 (2.98)	R-15.0 (2.65)	0.067 (0.38)	0.058 (0.031)
R-25 (4.40)	R-26.9 (4.74)	R-23.1 (4.06)	0.043 (0.25)	0.048 (0.025)

Detail 7.1.3

Exterior Insulated Concrete Block Wall with Thermally Broken ISO Clip System with Horizontal Sub-Girt Supporting Cladding – Clear Wall

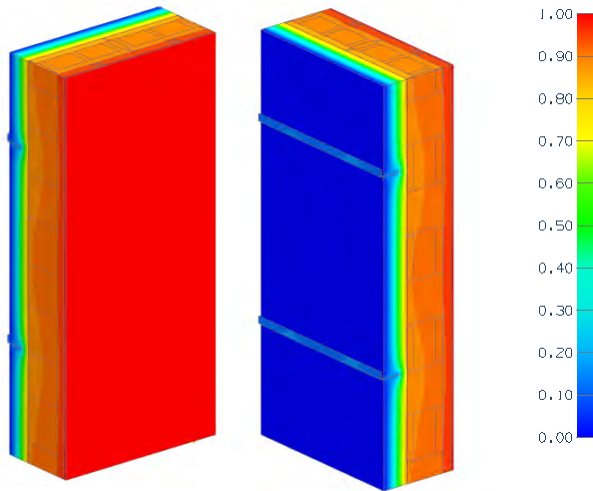

View from Interior View from Exterior

Thermal Performance Indicators

Assembly 1D (Nominal) R-Value	R_{1D}	R-4.2 (0.74 RSI) + exterior insulation
Transmittance / Resistance	U_o , R_o	“Clear wall” U- and R-value

Nominal (1D) vs. Assembly Performance Indicators

Horizontal Clip Spacing	Exterior Insulation 1D R-Value (RSI)	R_{1D} ft ² ·hr·°F / Btu (m ² K / W)	24" Vertical Clip Spacing		36" Vertical Clip Spacing		48" Vertical Clip Spacing		60" Vertical Clip Spacing	
			R_o ft ² ·hr·°F / Btu (m ² K / W)	U_o Btu/ft ² ·hr·°F (W/m ² K)	R_o ft ² ·hr·°F / Btu (m ² K / W)	U_o Btu/ft ² ·hr·°F (W/m ² K)	R_o ft ² ·hr·°F / Btu (m ² K / W)	U_o Btu/ft ² ·hr·°F (W/m ² K)	R_o ft ² ·hr·°F / Btu (m ² K / W)	U_o Btu/ft ² ·hr·°F (W/m ² K)
16" o.c.	16.8 (2.96)	21 (3.70)	R-15.2 (2.68)	0.066 (0.374)	R-16.4 (2.89)	0.061 (0.345)	R-17.3 (3.04)	0.058 (0.329)	R-17.9 (3.15)	0.056 (0.318)
	21.0 (3.70)	25.2 (4.44)	R-16.9 (2.98)	0.059 (0.336)	R-18.6 (3.28)	0.054 (0.305)	R-19.8 (3.49)	0.050 (0.286)	R-20.7 (3.65)	0.048 (0.274)
	25.2 (4.44)	29.4 (5.18)	R-18.4 (3.24)	0.054 (0.309)	R-20.6 (3.63)	0.049 (0.276)	R-22.2 (3.91)	0.045 (0.256)	R-23.4 (4.12)	0.043 (0.243)
24" o.c.	16.8 (2.96)	21 (3.70)	R-16.1 (2.83)	0.062 (0.353)	R-17.2 (3.03)	0.058 (0.33)	R-18.0 (3.16)	0.056 (0.316)	R-18.5 (3.26)	0.054 (0.307)
	21.0 (3.70)	25.2 (4.44)	R-18.0 (3.17)	0.056 (0.316)	R-19.7 (3.46)	0.051 (0.289)	R-20.7 (3.65)	0.048 (0.274)	R-21.5 (3.78)	0.047 (0.264)
	25.2 (4.44)	29.4 (5.18)	R-19.6 (3.46)	0.051 (0.289)	R-21.8 (3.84)	0.046 (0.26)	R-23.2 (4.09)	0.043 (0.244)	R-24.3 (4.28)	0.041 (0.234)
32" o.c.	16.8 (2.96)	21 (3.70)	R-16.8 (2.95)	0.060 (0.339)	R-17.8 (3.14)	0.056 (0.319)	R-18.4 (3.25)	0.054 (0.308)	R-18.9 (3.33)	0.053 (0.300)
	21.0 (3.70)	25.2 (4.44)	R-18.8 (3.32)	0.053 (0.301)	R-20.4 (3.59)	0.049 (0.279)	R-21.3 (3.76)	0.047 (0.266)	R-22.0 (3.88)	0.045 (0.258)
	25.2 (4.44)	29.4 (5.18)	R-20.6 (3.63)	0.048 (0.275)	R-22.7 (4.00)	0.044 (0.250)	R-24.0 (4.22)	0.042 (0.237)	R-24.9 (4.39)	0.040 (0.228)

Detail 7.1.4

Exterior Insulated Concrete Assembly with Nvelope – NV1 Clip System Supporting Cladding – Clear Wall

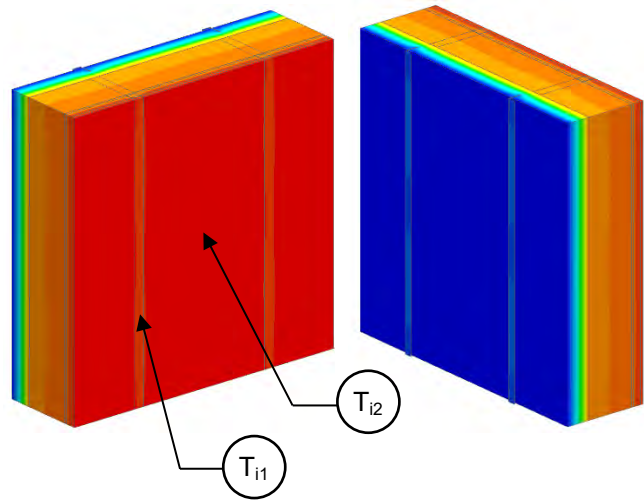

Thermal Performance Indicators

Assembly 1D (Nominal) R-Value	R_{1D}	R-3.4 (0.59 RSI) + exterior insulation
Transmittance / Resistance	U_o, R_o	“clear wall” U- and R-value
Surface Temperature Index ¹	T_i	0 = exterior temperature 1 = interior temperature

¹Assumptions and limitations for surface temperatures identified in ASHRAE 1365-RP

View from Interior

View from Exterior

Nominal (1D) vs. Assembly Performance Indicators

Exterior Insulation 1D R-Value (RSI)	R_{1D} ft ² ·hr·°F / Btu (m ² K / W)	24" Vertical Spacing		36" Vertical Spacing		48" Vertical Spacing	
		R_o ft ² ·hr·°F / Btu (m ² K / W)	U_o Btu/ft ² ·hr·°F (W/m ² K)	R_o ft ² ·hr·°F / Btu (m ² K / W)	U_o Btu/ft ² ·hr·°F (W/m ² K)	R_o ft ² ·hr·°F / Btu (m ² K / W)	U_o Btu/ft ² ·hr·°F (W/m ² K)
R-8.4 (1.48)	R-11.8 (2.07)	R-10.2 (1.79)	0.098 (0.56)	R-10.5 (1.85)	0.095 (0.54)	R-10.7 (1.88)	0.094 (0.53)
R-12.6 (2.22)	R-16.0 (2.81)	R-12.8 (2.26)	0.078 (0.44)	R-13.4 (2.36)	0.075 (0.42)	R-13.8 (2.43)	0.073 (0.41)
R-16.8 (2.96)	R-20.2 (3.55)	R-15.3 (2.70)	0.065 (0.37)	R-16.4 (2.88)	0.061 (0.35)	R-17.0 (2.99)	0.059 (0.34)
R-21.0 (3.7)	R-24.4 (4.29)	R-17.4 (3.07)	0.057 (0.33)	R-18.9 (3.33)	0.053 (0.30)	R-19.9 (3.50)	0.050 (0.29)
R-25.2 (4.44)	R-28.6 (5.03)	R-19.3 (3.40)	0.052 (0.29)	R-21.3 (3.75)	0.047 (0.27)	R-22.5 (3.97)	0.044 (0.25)

Temperature Indices

	R8.4	R12.6	R16.8	R21	R25.1	
T_{i1}	0.80	0.84	0.86	0.88	0.89	Min T on interior concrete surface, at clip
T_{i2}	0.81	0.85	0.87	0.89	0.90	Max T on interior concrete surface, away from clips

Detail 7.1.5

Exterior Insulated Concrete Block Wall Assembly with Nvelope – NV1 Clip System Supporting Cladding – Clear Wall

Thermal Performance Indicators

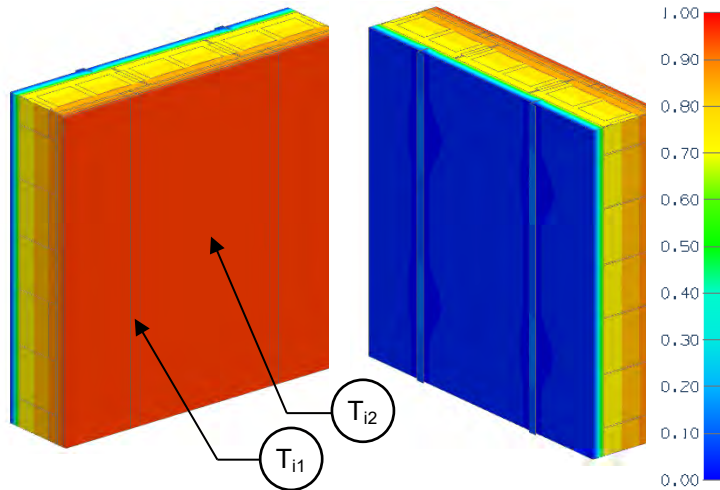

Assembly 1D (Nominal) R-Value	R _{1D}	R-3.9 (0.69 RSI) + exterior insulation
Transmittance / Resistance	U _o , R _o	“clear wall” U- and R-value
Surface Temperature Index ¹	T _i	0 = exterior temperature 1 = interior temperature

¹Assumptions and limitations for surface temperatures identified in ASHRAE 1365-RP

View from Interior

View from Exterior

Nominal (1D) vs. Assembly Performance Indicators

Exterior Insulation 1D R-Value (RSI)	R _{1D} ft ² ·hr·°F / Btu (m ² K / W)	24" Vertical Spacing		36" Vertical Spacing		48" Vertical Spacing	
		R _o ft ² ·hr·°F / Btu (m ² K / W)	U _o Btu/ft ² ·hr·°F (W/m ² K)	R _o ft ² ·hr·°F / Btu (m ² K / W)	U _o Btu/ft ² ·hr·°F (W/m ² K)	R _o ft ² ·hr·°F / Btu (m ² K / W)	U _o Btu/ft ² ·hr·°F (W/m ² K)
R-8.4 (1.48)	R-12.3 (2.17)	R-10.8 (1.91)	0.092 (0.52)	R-11.2 (1.96)	0.090 (0.51)	R-11.3 (1.99)	0.088 (0.50)
R-12.6 (2.22)	R-16.5 (2.91)	R-13.5 (2.38)	0.074 (0.42)	R-14.1 (2.49)	0.071 (0.40)	R-14.4 (2.54)	0.069 (0.39)
R-16.8 (2.96)	R-20.7 (3.65)	R-16.1 (2.83)	0.062 (0.35)	R-17.1 (3.01)	0.058 (0.33)	R-17.7 (3.12)	0.057 (0.32)
R-21.0 (3.70)	R-24.9 (4.39)	R-18.3 (3.22)	0.055 (0.31)	R-19.7 (3.48)	0.051 (0.29)	R-20.6 (3.63)	0.048 (0.28)
R-25.2 (4.44)	R-29.1 (5.13)	R-20.2 (3.56)	0.049 (0.28)	R-22.2 (3.91)	0.045 (0.26)	R-23.4 (4.12)	0.043 (0.24)

Temperature Indices

	R8.4	R12.6	R16.8	R21	R25.1	
T _{i1}	0.81	0.85	0.87	0.88	0.89	Min T on interior concrete surface, at clip
T _{i2}	0.82	0.86	0.88	0.89	0.90	Max T on interior concrete surface, away from clips

Detail 7.1.6

Exterior Insulated Concrete Mass Wall Assembly with Hohmann & Barnard Masonry Zinc 2-Seal Anchor Supporting Brick Veneer – Clear Wall

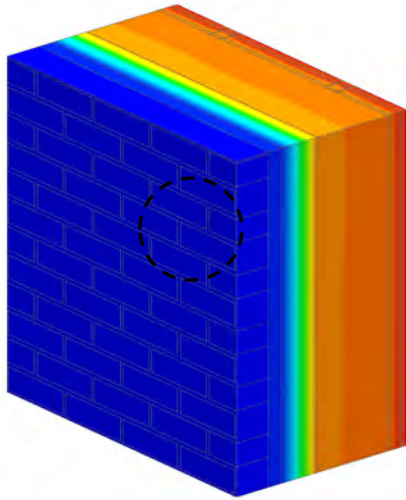

View of Exterior

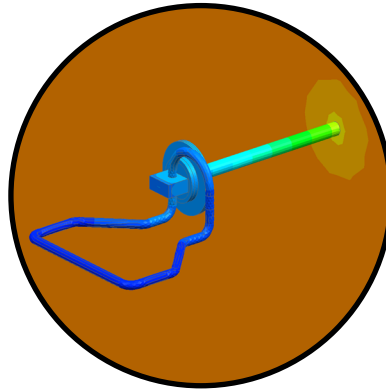

View of Anchoring Tie

Thermal Performance Indicators



Assembly 1D (Nominal) R-Value	R_{1D}	R-4.3 (0.76 RSI) + exterior insulation
Transmittance / Resistance	U_o , R_o	“Clear wall” U- and R-value: a = without batt insulation

Nominal (1D) vs. Assembly Performance Indicators

Exterior Insulation 1D R-Value (RSI)	R_{1D} ft ² ·hr·°F / Btu (m ² K / W)	8” Vertical Clip Spacing		16” Vertical Clip Spacing		24” Vertical Clip Spacing	
		R_o ft ² ·hr·°F / Btu (m ² K / W)	U_o Btu/ft ² ·hr ·°F (W/m ² K)	R_o ft ² ·hr·°F / Btu (m ² K / W)	U_o Btu/ft ² ·hr ·°F (W/m ² K)	R_o ft ² ·hr·°F / Btu (m ² K / W)	U_o Btu/ft ² ·hr ·°F (W/m ² K)
R-4.2 (0.74)	R-8.5 (1.50)	R-7.1 (1.25)	0.141 (0.800)	R-7.6 (1.33)	0.132 (0.750)	R-7.8 (1.37)	0.129 (0.730)
R-8.4 (1.48)	R-12.7 (2.24)	R-9.4 (1.66)	0.106 (0.604)	R-10.6 (1.87)	0.094 (0.535)	R-11.1 (1.96)	0.090 (0.509)
R-12.6 (2.22)	R-16.9 (2.98)	R-11.4 (2.01)	0.088 (0.497)	R-13.4 (2.36)	0.075 (0.424)	R-14.3 (2.52)	0.070 (0.397)
R-16.8 (2.96)	R-21.1 (3.72)	R-13.3 (2.35)	0.075 (0.426)	R-16.0 (2.82)	0.062 (0.355)	R-17.4 (3.06)	0.058 (0.327)

Detail 7.1.7

Exterior Insulated Concrete Mass Wall Assembly with Hohmann & Barnard Masonry Stainless Steel 2-Seal Thermal Wing Nut Anchor Supporting Brick Veneer – Clear Wall

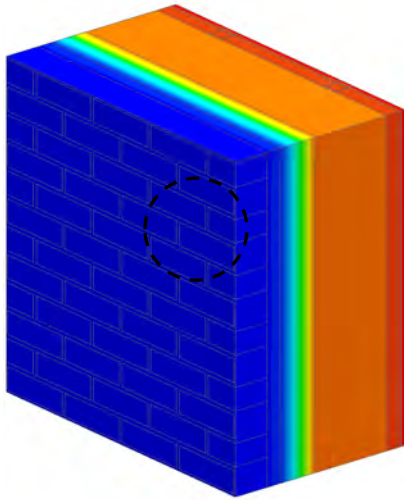

View of Exterior

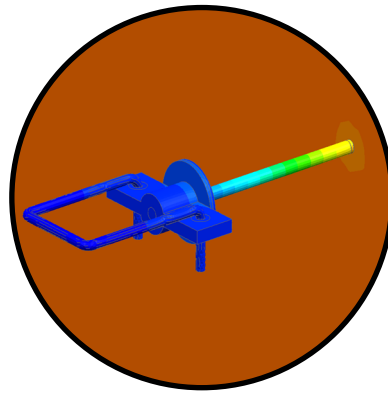

View of Anchoring Tie

Thermal Performance Indicators



Assembly 1D (Nominal) R-Value	R_{1D}	R-4.4 (0.76 RSI) + exterior insulation
Transmittance / Resistance	U_o , R_o	"Clear wall" U - and R-value

Nominal (1D) vs. Assembly Performance Indicators

Exterior Insulation 1D R-Value (RSI)	R_{1D} ft ² ·hr·°F / Btu (m ² K / W)	8" Vertical Clip Spacing		16" Vertical Clip Spacing		24" Vertical Clip Spacing	
		R_o ft ² ·hr·°F / Btu (m ² K / W)	U_o Btu/ft ² ·hr·°F (W/m ² K)	R_o ft ² ·hr·°F / Btu (m ² K / W)	U_o Btu/ft ² ·hr·°F (W/m ² K)	R_o ft ² ·hr·°F / Btu (m ² K / W)	U_o Btu/ft ² ·hr·°F (W/m ² K)
R-4.2 (0.74)	R-8.6 (1.51)	R-7.7 (1.36)	0.129 (0.733)	R-7.9 (1.40)	0.126 (0.714)	R-8.0 (1.41)	0.125 (0.710)
R-8.4 (1.48)	R-12.8 (2.25)	R-11.4 (2.00)	0.088 (0.499)	R-11.8 (2.08)	0.084 (0.480)	R-12.0 (2.11)	0.083 (0.473)
R-12.6 (2.22)	R-17.0 (2.99)	R-14.9 (2.63)	0.067 (0.380)	R-15.7 (2.76)	0.064 (0.362)	R-16.0 (2.81)	0.063 (0.356)
R-16.8 (2.96)	R-21.2 (3.73)	R-18.5 (3.26)	0.054 (0.307)	R-19.6 (3.45)	0.051 (0.290)	R-19.9 (3.50)	0.050 (0.286)

Detail 7.1.8

Precast Sandwich Panel Wall Assembly with Concrete Panel Joints – Clear Wall

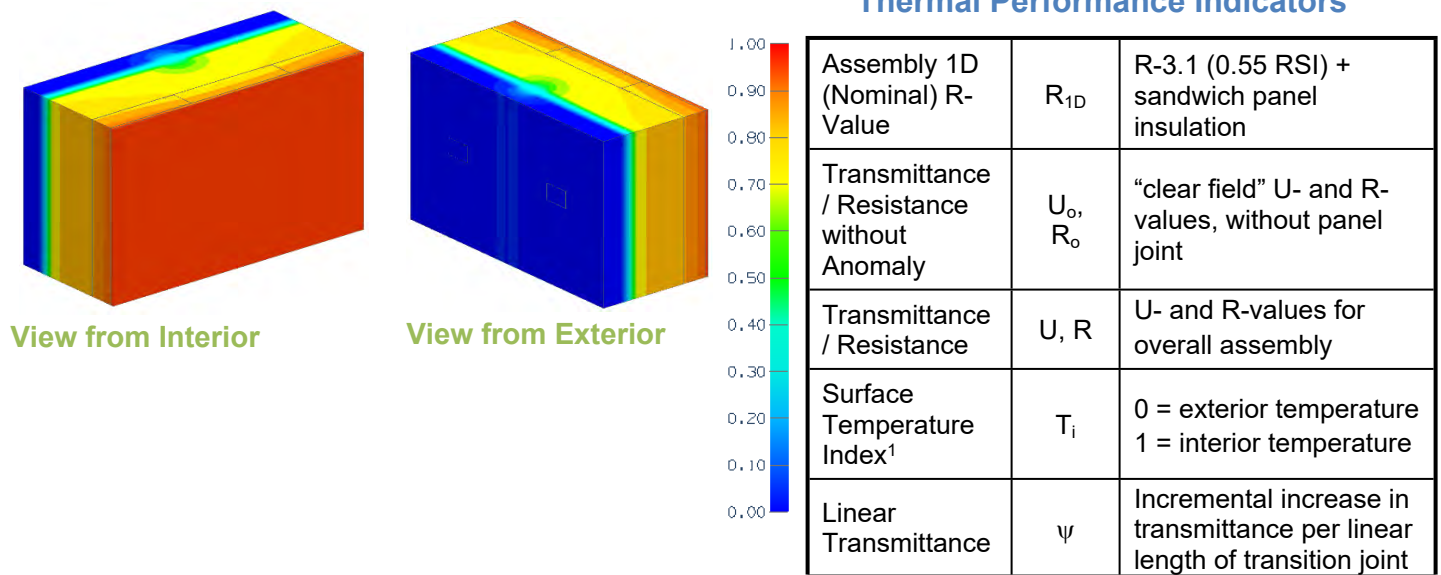

¹Assumptions and limitations for surface temperatures identified in ASHRAE 1365-RP

Nominal (1D) vs. Assembly Performance Indicators

Base Assembly – Wall

Sandwich Panel Insulation 1D R-value (RSI)	R_{1Dw} ft ² ·hr·°F / Btu (m ² K / W)	R_o ft ² ·hr·°F / Btu (m ² K / W)	U_o Btu/ft ² ·hr·°F (W/m ² K)
R-10 (1.76)	R-13.1 (2.31)	R-12.8 (2.26)	0.078 (0.44)
R-15 (2.64)	R-18.1 (3.19)	R-17.7 (3.12)	0.056 (0.32)
R-20 (3.52)	R-23.1 (4.07)	R-22.6 (3.98)	0.044 (0.25)

Panel Joint Linear Transmittance

Sandwich Panel Insulation 1D R-value (RSI)	R ft ² ·hr·°F / Btu (m ² K / W)	U Btu/ft ² ·hr·°F (W/m ² K)	ψ Btu/ft·hr·°F (W/m K)
R-10 (1.76)	R-7.1 (1.26)	0.140 (0.79)	0.211 (0.37)
R-15 (2.64)	R-8.4 (1.48)	0.119 (0.68)	0.214 (0.37)
R-20 (3.52)	R-9.5 (1.68)	0.105 (0.60)	0.207 (0.36)

Detail 7.1.9

Precast Sandwich Panel Wall Assembly with Tigerloc Thermally Broken Panel Joints – Clear Wall

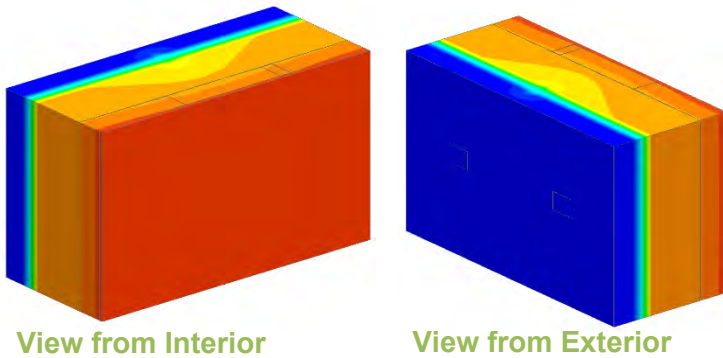

Thermal Performance Indicators

Assembly 1D (Nominal) R-Value	R_{1D}	R-3.1 (0.55 RSI) + sandwich panel insulation
Transmittance / Resistance without Anomaly	U_o, R_o	“clear field” U- and R-values, without panel joint
Transmittance / Resistance	U, R	U- and R-values for overall assembly
Surface Temperature Index ¹	T_i	0 = exterior temperature 1 = interior temperature
Linear Transmittance	ψ	Incremental increase in transmittance per linear length of transition joint

¹Assumptions and limitations for surface temperatures identified in ASHRAE 1365-RP

Nominal (1D) vs. Assembly Performance Indicators

Base Assembly – Wall

Sandwich Panel Insulation 1D R-value (RSI)	R_{1Dw} ft ² ·hr·°F / Btu (m ² K / W)	R_o ft ² ·hr·°F / Btu (m ² K / W)	U_o Btu/ft ² ·hr·°F (W/m ² K)
R-10 (1.76)	R-13.1 (2.31)	R-12.8 (2.26)	0.078 (0.44)
R-15 (2.64)	R-18.1 (3.19)	R-17.7 (3.12)	0.056 (0.32)
R-20 (3.52)	R-23.1 (4.07)	R-22.6 (3.98)	0.044 (0.25)

Panel Joint Linear Transmittance

Sandwich Panel Insulation 1D R-value (RSI)	R ft ² ·hr·°F / Btu (m ² K / W)	U Btu/ft ² ·hr·°F (W/m ² K)	ψ Btu/ft·hr·°F (W/m K)
R-10 (1.76)	R-9.3 (1.65)	0.107 (0.61)	0.099 (0.17)
R-15 (2.64)	R-12.0 (2.11)	0.084 (0.47)	0.092 (0.16)
R-20 (3.52)	R-14.5 (2.56)	0.069 (0.39)	0.084 (0.15)

Detail 7.1.10

Precast Concrete Sandwich Panel Wall Assembly with FRP Connectors – Clear Wall Detail

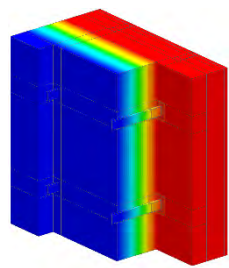

CC Connectors

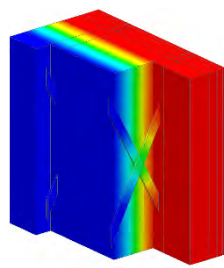

X Connectors



Thermal Performance Indicators

Assembly 1D (Nominal) R-Value	R_{1D}	R-2.76 (0.49 RSI) + insulation
Transmittance / Resistance without Anomaly	U_o, R_o	“clear field” U- and R-value, without connectors or joint
Transmittance / Resistance	U, R	U- and R-values for the overall assembly
Linear Transmittance	Ψ	Incremental increase in transmittance for vertical joints
Point Transmittance	χ	Incremental increase in transmittance for connector

Scenarios

Scenario	Connector Arrangement
A	CC Connectors, 16" x 16" spacing
B	X Connectors, 16" x 32" spacing

Nominal (1D) vs. Assembly Performance Indicators

Base Assembly – Wall

Wall Insulation R-Value/in	Wall Insulation 1D R-Value (RSI)	R_{1D} ft ² ·hr·°F / Btu (m ² K / W)	R_o ft ² ·hr·°F / Btu (m ² K / W)	U_o Btu/ft ² ·hr·°F (W/m ² K)
5	R-40 (7.04)	R-42.8 (7.53)	R-42.3 (7.45)	0.024 (0.13)
6	R-48 (8.45)	R-50.8 (8.94)	R-50.3 (8.86)	0.020 (0.11)
7	R-56 (9.86)	R-58.8 (10.35)	R-58.3 (10.27)	0.017 (0.10)

Connector Point Transmittance

Scenario	Wall Insulation R-Value/in	R ft ² ·hr·°F / Btu (m ² K / W)	U Btu/ft ² ·hr·°F (W/m ² K)	χ Btu/hr·°F (W/K)
A	5	R-39.5 (6.96)	0.025 (0.14)	0.0008 (0.0016)
	6	R-46.3 (8.16)	0.022 (0.12)	0.0008 (0.0016)
	7	R-53.0 (9.33)	0.019 (0.11)	0.0009 (0.0016)
B	5	R-40.1 (7.07)	0.025 (0.14)	0.0013 (0.0024)
	6	R-47.3 (8.33)	0.021 (0.12)	0.0012 (0.0023)
	7	R-54.4 (9.58)	0.018 (0.10)	0.0012 (0.0023)

Vertical Joint Linear Transmittance

Wall Insulation R-Value/in	R ft ² ·hr·°F / Btu (m ² K / W)	U Btu/ft ² ·hr·°F (W/m ² K)	Ψ Btu/ft·hr·°F (W/mK)
5	R-39.4 (6.94)	0.025 (0.14)	0.0001 (0.0002)
6	R-46.0 (8.10)	0.022 (0.12)	0.0004 (0.0007)
7	R-52.4 (9.22)	0.019 (0.11)	0.0006 (0.0010)

Detail 7.1.11

Exterior Insulated Concrete Block Wall with Armadillo FRR Horizontal Z-Girts Supporting Cladding – Clear Wall

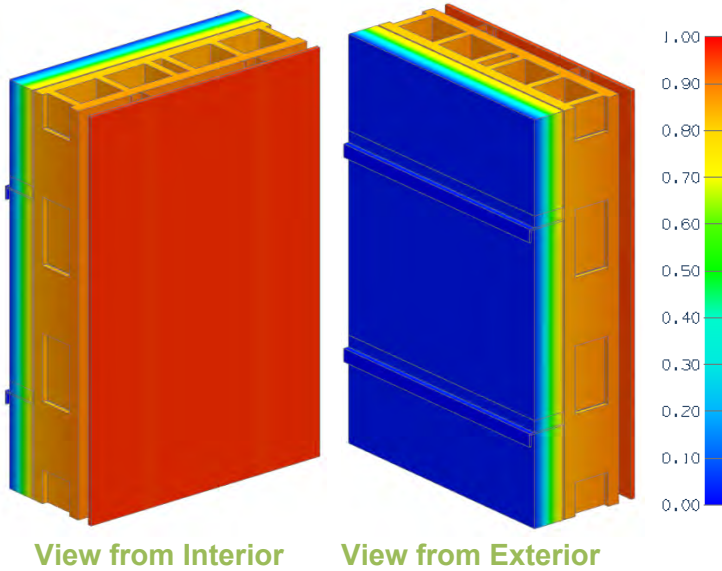

Thermal Performance Indicators

Assembly 1D (Nominal) R-Value	R_{1D}	R-5.6 (0.98 RSI) + exterior insulation
Transmittance / Resistance	U_o, R_o	“clear wall” U- and R-value

¹Assumptions and limitations for surface temperatures identified in ASHRAE 1365-RP

Nominal (1D) vs. Assembly Performance Indicators

Exterior Insulation 1D R-Value (RSI)	R_{1D} ft ² ·hr·°F / Btu (m ² K / W)	R_o ft ² ·hr·°F / Btu (m ² K / W)	U_o Btu/ft ² ·hr ·°F (W/m ² K)
R-10.0 (1.76)	R-15.6 (2.74)	R-13.5 (2.37)	0.074 (0.42)
R-15.0 (2.64)	R-20.6 (3.62)	R-18.2 (3.20)	0.055 (0.31)
R-20.0 (3.52)	R-25.6 (4.50)	R-22.9 (4.04)	0.044 (0.25)
R-25.0 (4.40)	R-30.6 (5.38)	R-27.6 (4.86)	0.036 (0.21)

Detail 7.1.12

Exterior Insulated Concrete Block Wall with Vertical Clips Supporting Cladding – Clear Wall

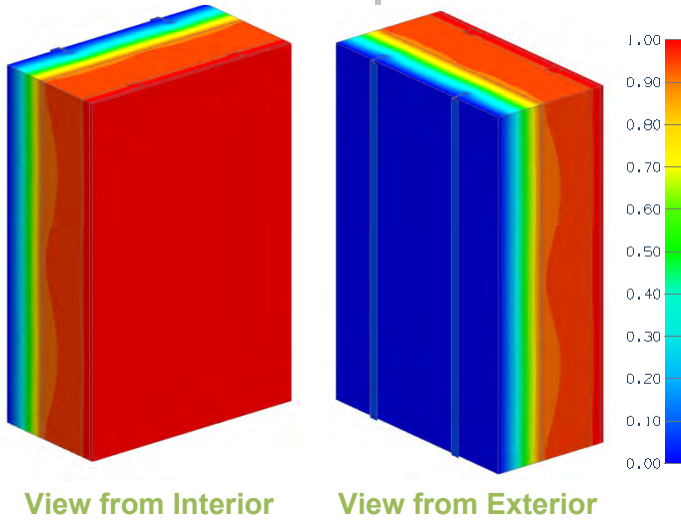

Thermal Performance Indicators

Assembly 1D (Nominal) R-Value	R_{1D}	R-3.9 (0.69) + insulation
Transmittance / Resistance without Anomaly	U_o, R_o	“clear field” U- and R-value, without connectors or joint

Nominal (1D) vs. Assembly Performance Indicators

Exterior Insulation 1D R-Value (RSI)	R_{1D} ft ² ·hr·°F / Btu (m ² K / W)	R_o ft ² ·hr·°F / Btu (m ² K / W)	U_o Btu/ft ² ·hr ·°F (W/m ² K)
R-8.4 (1.48)	R-12.3 (2.17)	R-10.2 (1.79)	0.098 (0.56)
R-12.6 (2.22)	R-16.5 (2.91)	R-12.2 (2.14)	0.082 (0.47)
R-16.8 (2.96)	R-20.7 (3.65)	R-14.4 (2.53)	0.070 (0.40)
R-21.0 (3.70)	R-24.9 (4.39)	R-16.2 (2.85)	0.062 (0.35)
R-25.2 (4.44)	R-29.1 (5.13)	R-17.9 (3.16)	0.056 (0.32)
R-29.4 (5.18)	R-33.3 (5.87)	R-19.6 (3.45)	0.051 (0.29)

Detail 7.1.13

Exterior Insulated Concrete Block Wall Assembly with Brick Ties Supporting Brick Veneer – Clear Wall

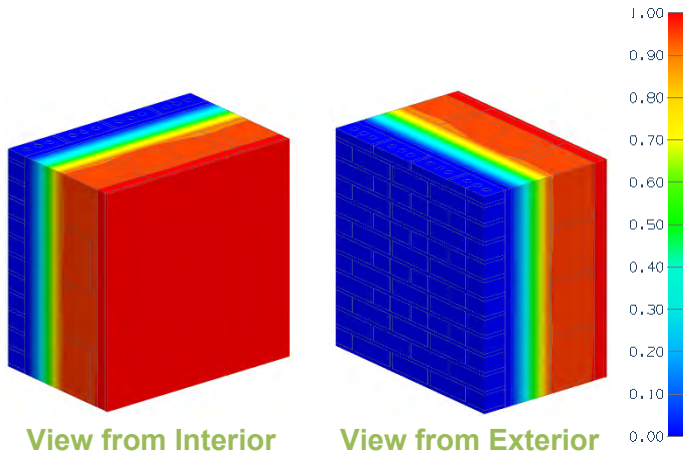

Thermal Performance Indicators

Assembly 1D (Nominal) R-Value	R_{1D}	R-5.6 (0.99) + insulation
Transmittance / Resistance without Anomaly	U_o, R_o	“clear field” U- and R-value, without connectors or joint
Surface Temperature Index ¹	T_i	0 = exterior temperature 1 = interior temperature

Nominal (1D) vs. Assembly Performance Indicators

Exterior Insulation 1D R-Value (RSI)	R_{1D} ft ² ·hr·°F / Btu (m ² K / W)	R_o ft ² ·hr·°F / Btu (m ² K / W)	U_o Btu/ft ² ·hr ·°F (W/m ² K)
R-5.0 (0.88)	R-10.6 (1.87)	R-10.4 (1.83)	0.096 (0.55)
R-10.0 (1.76)	R-15.6 (2.75)	R-14.2 (2.50)	0.070 (0.40)
R-15.0 (2.64)	R-20.6 (3.63)	R-17.8 (3.13)	0.056 (0.32)
R-20.0 (3.52)	R-25.6 (4.51)	R-20.8 (3.66)	0.048 (0.27)
R-25.0 (4.40)	R-30.6 (5.39)	R-23.7 (4.17)	0.042 (0.24)
R-30.0 (5.28)	R-35.6 (6.27)	R-26.8 (4.71)	0.037 (0.21)
R-35.0 (6.16)	R-40.6 (7.15)	R-29.4 (5.17)	0.034 (0.19)
R-40.0 (7.04)	R-45.6 (8.04)	R-31.9 (5.61)	0.031 (0.18)

Detail 7.1.14

Interior Insulated Concrete Mass Wall with 1 5/8" Steel Stud (16" o.c.) Supporting Interior Finish Wall Assembly – Clear Wall

Thermal Performance Indicators

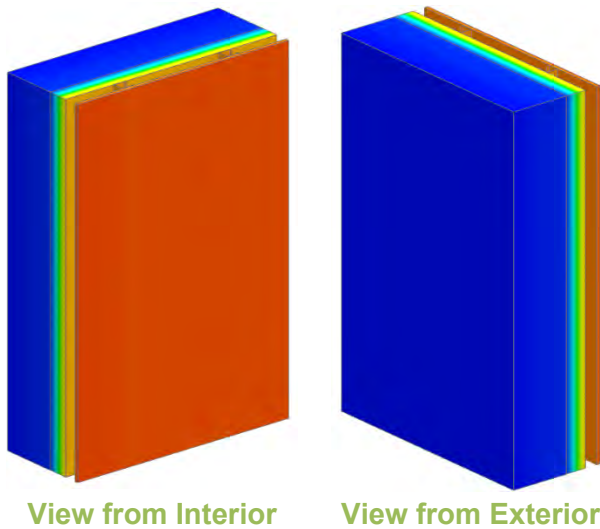

Assembly 1D (Nominal) R-Value	R_{1D}	R-2.9 (0.51 RSI) + interior insulation
Transmittance / Resistance	U_o , R_o	"clear wall" U- and R-value

Nominal (1D) vs. Assembly Performance Indicators

Interior Insulation 1D R-value (RSI)	R_{1D} ft ² ·hr·°F / Btu (m ² K / W)	R_o ft ² ·hr·°F / Btu (m ² K / W)	U_o Btu/ft ² ·hr ·°F (W/m ² K)
R-10 (1.76)	R-12.9 (2.27)	R-12.9 (2.26)	0.078 (0.44)
R-12.5 (2.20)	R-15.4 (2.71)	R-15.4 (2.70)	0.065 (0.37)
R-15 (2.64)	R-17.9 (3.15)	R-17.9 (3.14)	0.056 (0.32)

Detail 7.1.15

Precast Sandwich Panel Wall Assembly with Steel Connectors and 3 5/8" x 1 5/8" Steel Stud (16" o.c.) – Clear Wall

Thermal Performance Indicators

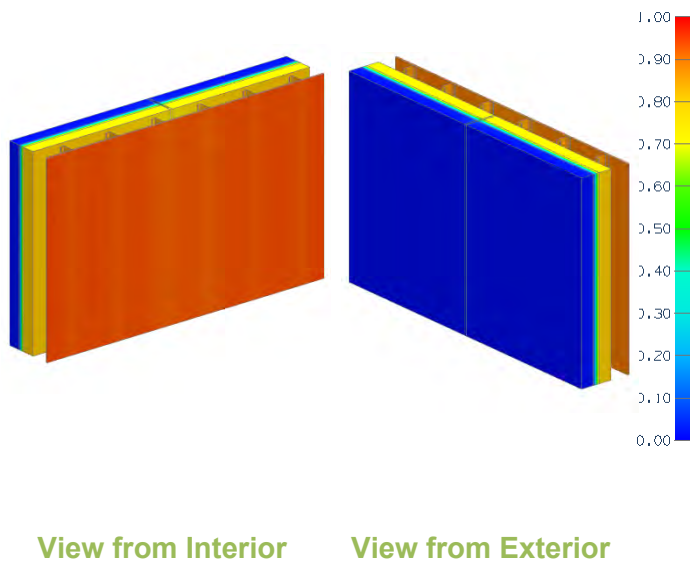

Assembly 1D (Nominal) R-Value	R_{1D}	R-3.9 (0.69 RSI) + sandwich panel insulation
Transmittance / Resistance without Anomaly	U_o, R_o	"clear wall" U- and R-value without panel joints
Transmittance / Resistance	U_j, R_j	U and R values for: j = panel joint
Linear Transmittance	Ψ_j	Incremental increase in transmittance per linear length of: j = panel joint

View from Interior

View from Exterior

Nominal (1D) vs. Assembly Performance Indicators

Base Assembly – Panel without Joints

Steel Connector Spacing in (mm)	Sandwich Panel Insulation 1D R-value (RSI)	R_{1D} ft ² ·hr·°F / Btu (m ² K / W)	R_o ft ² ·hr·°F / Btu (m ² K / W)	U_o Btu/ft ² ·hr·°F (W/m ² K)
16 (406)	R-10 (1.76)	R-13.9 (2.45)	R-12.0 (2.11)	0.083 (0.47)
24 (610)	R-10 (1.76)	R-13.9 (2.45)	R-12.6 (2.22)	0.079 (0.45)
24 (610)	R-15 (2.64)	R-18.9 (3.33)	R-17.2 (3.03)	0.058 (0.33)
24 (610)	R-20 (3.52)	R-23.9 (4.21)	R-22.4 (3.94)	0.045 (0.25)
36 (914)	R-10 (1.76)	R-13.9 (2.45)	R-12.6 (2.22)	0.079 (0.45)
48 (1220)	R-10 (1.76)	R-13.9 (2.45)	R-12.6 (2.22)	0.079 (0.45)

Panel Joint Linear Transmittances

Panel Perimeter	Steel Connector Spacing in (mm)	Sandwich Panel Insulation 1D R-value (RSI)	R_j ft ² ·hr·°F / Btu (m ² K / W)	U_j Btu/ft ² ·hr·°F (W/m ² K)	Ψ_j Btu/ft ² ·hr·°F (W/m ² K)
Concrete	24 (610)	R-10 (1.76)	R-6.2 (1.10)	0.160 (0.91)	0.653 (1.130)
Insulation	16 (406)	R-10 (1.76)	R-11.6 (2.03)	0.087 (0.49)	0.026 (0.046)
	24 (610)	R-10 (1.76)	R-11.7 (2.05)	0.086 (0.49)	0.026 (0.046)
	36 (914)	R-10 (1.76)	R-12.0 (2.11)	0.084 (0.48)	0.036 (0.062)
	48 (1220)	R-10 (1.76)	R-12.1 (2.12)	0.083 (0.47)	0.030 (0.052)

Detail 7.1.16 Exterior Insulated Concrete Mass Wall Assembly with 3/8 inch (9.5 mm) Stainless Steel Brackets Supporting 3” Stone Panels – Clear Wall

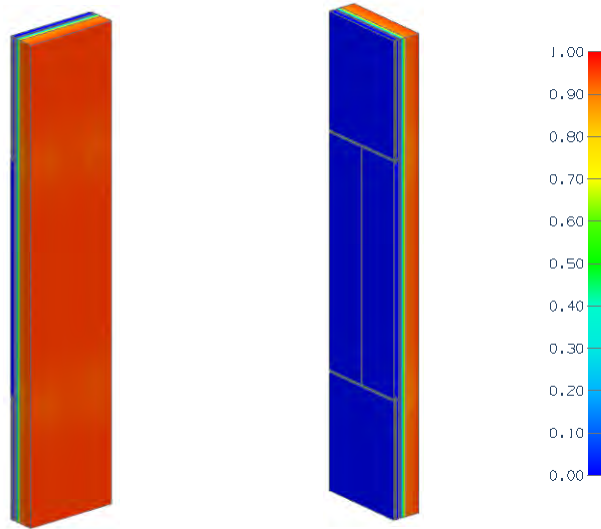

View from Interior

View from Exterior

Thermal Performance Indicators

Assembly 1D (Nominal) R-Value	R_{1D}	R-2.0 (0.35 RSI) + insulation
Transmittance / Resistance	U_o, R_o	“clear field” U- and R-value
Point Transmittance	χ	Incremental increase in transmittance for one bracket

Nominal (1D) vs. Assembly Performance Indicators

Exterior Insulation 1D R-Value (RSI)	R_{1D} ft ² ·hr·°F / Btu (m ² K / W)	R_o ft ² ·hr·°F / Btu (m ² K / W)	U_o Btu/ft ² ·hr ·°F (W/m ² K)	χ Btu/hr·°F (W/K)
R-5 (0.88)	R-7.0 (1.23)	R-6.7 (1.18)	0.149 (0.84)	0.109 (0.057)
R-15 (2.64)	R-17.0 (2.99)	R-15.7 (2.77)	0.064 (0.36)	0.096 (0.051)
R-25 (4.40)	R-27.0 (4.75)	R-24.5 (4.31)	0.041 (0.23)	0.077 (0.041)

Detail 7.1.17

Exterior Insulated Concrete Block Wall Assembly with SOPREMA SOPRA-XPS 20 and ACS-S Thermal Clip (16" o.c. Horizontal) Supporting Metal Cladding - Clear Wall

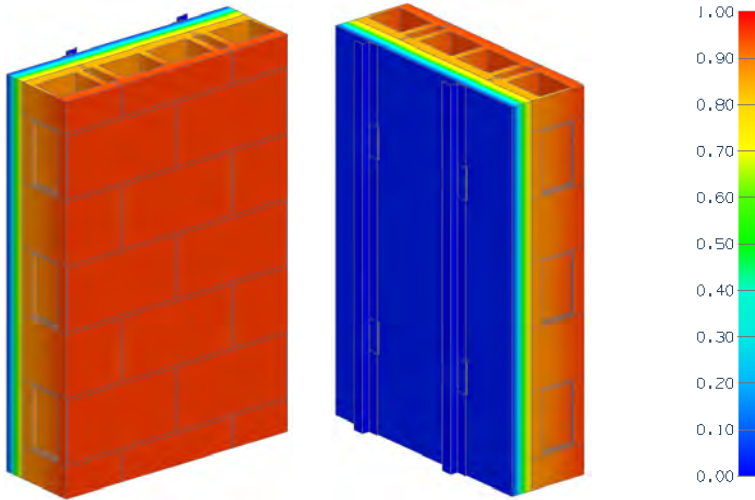

View from Interior View from Exterior

Thermal Performance Indicators

Assembly 1D (Nominal) R-Value	R_{1D}	R-2.87 (0.51 RSI) + exterior insulation
Transmittance / Resistance	U_o , R_o	"Clear wall" U- and R-value

Nominal (1D) vs. Assembly Performance Indicators

Exterior Insulation 1D R-value (RSI)	R_{1D} ft ² ·hr·°F / Btu (m ² K / W)	24" Vertical Spacing		36" Vertical Spacing		48" Vertical Spacing	
		R_o ft ² ·hr·°F / Btu (m ² K / W)	U_o Btu/ft ² ·hr·°F (W/m ² K)	R_o ft ² ·hr·°F / Btu (m ² K / W)	U_o Btu/ft ² ·hr·°F (W/m ² K)	R_o ft ² ·hr·°F / Btu (m ² K / W)	U_o Btu/ft ² ·hr·°F (W/m ² K)
R-15.0 (2.64)	R-17.9 (3.15)	R-16.7 (2.94)	0.060 (0.34)	R-17.0 (2.99)	0.059 (0.33)	R-17.1 (3.02)	0.058 (0.33)
R-20.0 (3.52)	R-22.9 (4.03)	R-21.1 (3.71)	0.047 (0.27)	R-21.6 (3.80)	0.046 (0.26)	R-21.8 (3.85)	0.046 (0.26)
R-25.0 (4.40)	R-27.9 (4.91)	R-25.3 (4.46)	0.039 (0.22)	R-26.0 (4.59)	0.038 (0.22)	R-26.5 (4.66)	0.038 (0.21)
R-30.0 (5.28)	R-32.9 (5.79)	R-29.6 (5.22)	0.034 (0.19)	R-30.6 (5.39)	0.033 (0.19)	R-31.1 (5.48)	0.032 (0.18)
R-35.0 (6.16)	R-37.9 (6.67)	R-33.8 (5.94)	0.030 (0.17)	R-34.9 (6.16)	0.029 (0.16)	R-35.6 (6.27)	0.028 (0.16)

Detail 7.1.18

Exterior Insulated Concrete Block Wall Assembly with SOPREMA SOPRA-XPS 20 and ACS-S Thermal Clip (24" o.c. Horizontal) Supporting Metal Cladding - Clear Wall

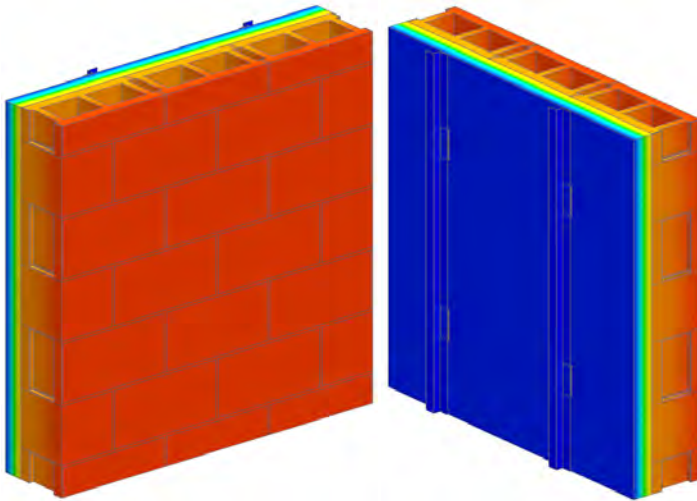

View from Interior

View from Exterior

Thermal Performance Indicators

Assembly 1D (Nominal) R-Value	R_{1D}	R-2.87 (0.51 RSI) + exterior insulation
Transmittance / Resistance	U_o , R_o	"Clear wall" U- and R-value

Nominal (1D) vs. Assembly Performance Indicators

Exterior Insulation 1D R-value (RSI)	R_{1D} ft ² ·hr·°F / Btu (m ² K / W)	24" Vertical Spacing		36" Vertical Spacing		48" Vertical Spacing	
		R_o ft ² ·hr·°F / Btu (m ² K / W)	U_o Btu/ft ² ·hr·°F (W/m ² K)	R_o ft ² ·hr·°F / Btu (m ² K / W)	U_o Btu/ft ² ·hr·°F (W/m ² K)	R_o ft ² ·hr·°F / Btu (m ² K / W)	U_o Btu/ft ² ·hr·°F (W/m ² K)
R-15.0 (2.64)	R-17.9 (3.15)	R-17.0 (2.99)	0.059 (0.33)	R-17.2 (3.03)	0.058 (0.33)	R-17.3 (3.05)	0.058 (0.33)
R-20.0 (3.52)	R-22.9 (4.03)	R-21.6 (3.80)	0.046 (0.26)	R-21.9 (3.86)	0.046 (0.26)	R-22.1 (3.89)	0.045 (0.26)
R-25.0 (4.40)	R-27.9 (4.91)	R-26.0 (4.59)	0.038 (0.22)	R-26.6 (4.68)	0.038 (0.21)	R-26.8 (4.72)	0.037 (0.21)
R-30.0 (5.28)	R-32.9 (5.79)	R-30.6 (5.39)	0.033 (0.19)	R-31.2 (5.50)	0.032 (0.18)	R-31.6 (5.57)	0.032 (0.18)
R-35.0 (6.16)	R-37.9 (6.67)	R-35.0 (6.16)	0.029 (0.16)	R-35.8 (6.30)	0.028 (0.16)	R-36.2 (6.38)	0.028 (0.16)

Detail 7.1.19

Exterior Insulated Concrete Block Wall Assembly with SOPREMA SOPRA-SPF 202 and ACS-S Thermal Clip (16" o.c. Horizontal) Supporting Metal Cladding - Clear Wall

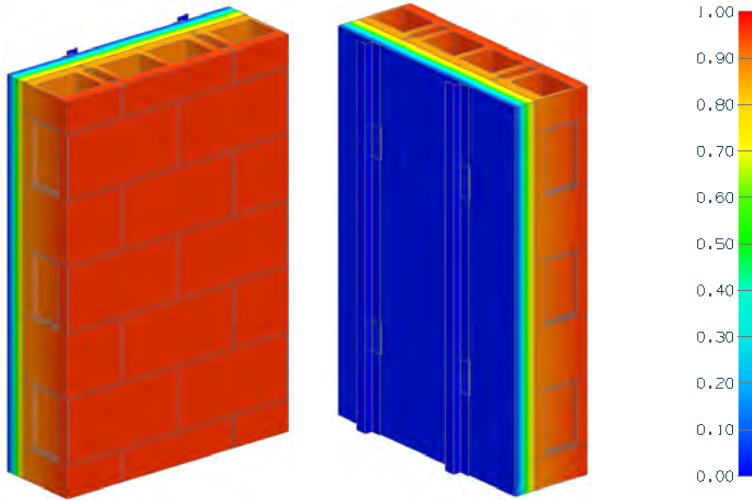

Thermal Performance Indicators

Assembly 1D (Nominal) R-Value	R_{1D}	R-2.87 (0.51 RSI) + exterior insulation
Transmittance / Resistance	U_o , R_o	"Clear wall" U- and R-value

View from Interior View from Exterior

Nominal (1D) vs. Assembly Performance Indicators

Exterior Insulation 1D R-value (RSI)	R_{1D} ft ² ·hr·°F / Btu (m ² K / W)	24" Vertical Spacing		36" Vertical Spacing		48" Vertical Spacing	
		R_o ft ² ·hr·°F / Btu (m ² K / W)	U_o Btu/ft ² ·hr ·°F (W/m ² K)	R_o ft ² ·hr·°F / Btu (m ² K / W)	U_o Btu/ft ² ·hr ·°F (W/m ² K)	R_o ft ² ·hr·°F / Btu (m ² K / W)	U_o Btu/ft ² ·hr ·°F (W/m ² K)
R-6.2 (1.09)	R-9.1 (1.60)	R-8.7 (1.53)	0.115 (0.65)	R-8.7 (1.54)	0.115 (0.65)	R-8.7 (1.54)	0.115 (0.65)
R-12.4 (2.18)	R-15.3 (2.69)	R-14.3 (2.52)*	0.070 (0.40)*	R-14.5 (2.56)*	0.069 (0.39)*	R-14.6 (2.57)*	0.068 (0.39)*
R-18.6 (3.28)	R-21.5 (3.78)	R-19.8 (3.49)	0.051 (0.29)	R-20.2 (3.56)	0.049 (0.28)	R-20.5 (3.60)	0.049 (0.28)
R-24.8 (4.37)	R-27.7 (4.87)	R-25.1 (4.42)	0.040 (0.23)	R-25.8 (4.55)	0.039 (0.22)	R-26.2 (4.61)	0.038 (0.22)
R-31.0 (5.46)	R-33.9 (5.97)	R-30.2 (5.32)	0.033 (0.19)	R-31.2 (5.50)	0.032 (0.18)	R-31.8 (5.61)	0.031 (0.18)
R-37.2 (6.55)	R-40.1 (7.06)	R-35.4 (6.23)	0.028 (0.16)	R-36.7 (6.47)	0.027 (0.15)	R-37.5 (6.60)	0.027 (0.15)

*Indicates interpolated value

Detail 7.1.20

Exterior Insulated Concrete Block Wall Assembly with SOPREMA SOPRA-SPF 202 and ACS-S Thermal Clip (24" o.c. Horizontal) Supporting Metal Cladding - Clear Wall

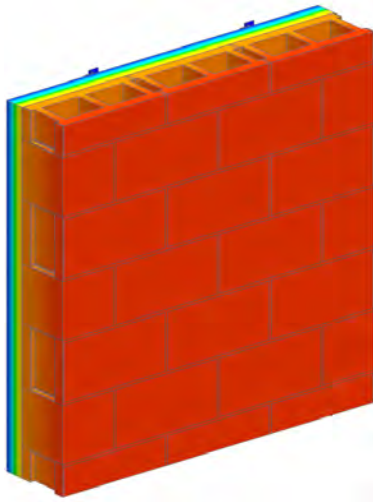

View from Interior

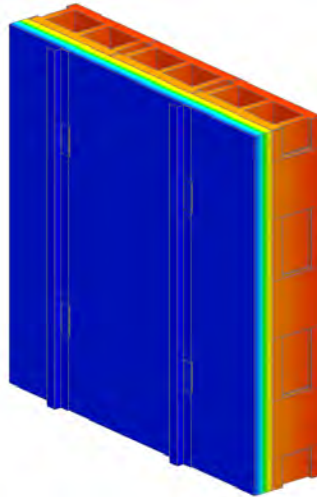

View from Exterior



Thermal Performance Indicators

Assembly 1D (Nominal) R-Value	R_{1D}	R-2.87 (0.51 RSI) + exterior insulation
Transmittance / Resistance	U_o / R_o	"Clear wall" U- and R-value

Nominal (1D) vs. Assembly Performance Indicators

Exterior Insulation 1D R-value (RSI)	R_{1D} ft ² ·hr·°F / Btu (m ² K / W)	24" Vertical Spacing		36" Vertical Spacing		48" Vertical Spacing	
		R_o ft ² ·hr·°F / Btu (m ² K / W)	U_o Btu/ft ² ·hr ·°F (W/m ² K)	R_o ft ² ·hr·°F / Btu (m ² K / W)	U_o Btu/ft ² ·hr ·°F (W/m ² K)	R_o ft ² ·hr·°F / Btu (m ² K / W)	U_o Btu/ft ² ·hr ·°F (W/m ² K)
R-6.2 (1.09)	R-9.1 (1.60)	R-8.7 (1.53)	0.115 (0.65)	R-8.7 (1.54)	0.114 (0.65)	R-8.7 (1.54)	0.114 (0.65)
R-12.4 (2.18)	R-15.3 (2.69)	R-14.5 (2.56)*	0.069 (0.39)*	R-14.7 (2.58)*	0.068 (0.39)*	R-14.7 (2.59)*	0.068 (0.39)*
R-18.6 (3.28)	R-21.5 (3.78)	R-20.2 (3.56)	0.049 (0.28)	R-20.5 (3.62)	0.049 (0.28)	R-20.7 (3.64)	0.048 (0.27)
R-24.8 (4.37)	R-27.7 (4.87)	R-25.8 (4.55)	0.039 (0.22)	R-26.3 (4.63)	0.038 (0.22)	R-26.6 (4.68)	0.038 (0.21)
R-31.0 (5.46)	R-33.9 (5.97)	R-31.2 (5.50)	0.032 (0.18)	R-32.0 (5.63)	0.031 (0.18)	R-32.4 (5.70)	0.031 (0.18)
R-37.2 (6.55)	R-40.1 (7.06)	R-36.7 (6.47)	0.027 (0.15)	R-37.7 (6.64)	0.027 (0.15)	R-38.2 (6.73)	0.026 (0.15)

*Indicates interpolated value

Detail 7.1.21

Exterior Insulated Concrete Block Wall Assembly with SOPREMA SOPRA-ISO V ALU and ACS-S Thermal Clip (16" o.c. Horizontal) Supporting Metal Cladding - Clear Wall

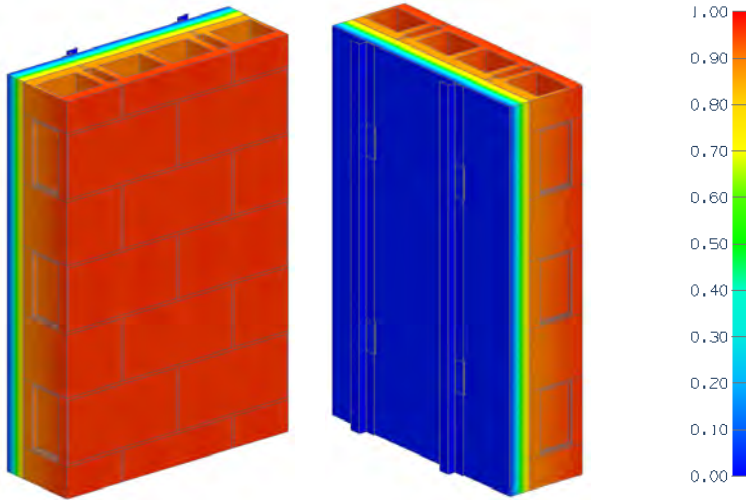

Thermal Performance Indicators

Assembly 1D (Nominal) R-Value	R _{1D}	R-2.87 (0.51 RSI) + exterior insulation
Transmittance / Resistance	U _o / R _o	"Clear wall" U- and R-value

View from Interior View from Exterior

Nominal (1D) vs. Assembly Performance Indicators

Exterior Insulation 1D R-value (RSI)	R _{1D} ft ² ·hr·°F / Btu (m ² K / W)	24" Vertical Spacing		36" Vertical Spacing		48" Vertical Spacing	
		R _o ft ² ·hr·°F / Btu (m ² K / W)	U _o Btu/ft ² ·hr ·°F (W/m ² K)	R _o ft ² ·hr·°F / Btu (m ² K / W)	U _o Btu/ft ² ·hr ·°F (W/m ² K)	R _o ft ² ·hr·°F / Btu (m ² K / W)	U _o Btu/ft ² ·hr ·°F (W/m ² K)
R-6.5 (1.14)	R-9.4 (1.65)	R-9.0 (1.59)	0.111 (0.63)	R-9.1 (1.60)	0.110 (0.63)	R-9.1 (1.60)	0.110 (0.63)
R-13.0 (2.29)	R-15.9 (2.79)	R-14.9 (2.62)*	0.067 (0.38)*	R-15.1 (2.66)*	0.066 (0.38)*	R-15.2 (2.68)*	0.066 (0.37)*
R-16.3 (2.86)	R-19.1 (3.37)	R-17.8 (3.13)*	0.056 (0.32)*	R-18.1 (3.19)*	0.055 (0.31)*	R-18.3 (3.22)*	0.055 (0.31)*
R-19.5 (3.43)	R-22.4 (3.94)	R-20.6 (3.63)	0.048 (0.28)	R-21.1 (3.72)	0.047 (0.27)	R-21.3 (3.76)	0.047 (0.27)
R-22.8 (4.01)	R-25.6 (4.51)	R-23.4 (4.12)*	0.043 (0.24)*	R-24.0 (4.23)*	0.042 (0.24)*	R-24.3 (4.29)*	0.041 (0.23)*
R-26.0 (4.58)	R-28.9 (5.08)	R-26.2 (4.61)	0.038 (0.22)	R-26.9 (4.75)	0.037 (0.21)	R-27.4 (4.82)	0.037 (0.21)
R-29.3 (5.15)	R-32.1 (5.66)	R-28.9 (5.09)*	0.035 (0.20)*	R-29.8 (5.25)*	0.034 (0.19)*	R-30.3 (5.34)*	0.033 (0.19)*
R-32.5 (5.72)	R-35.4 (6.23)	R-31.5 (5.55)	0.032 (0.18)	R-32.6 (5.75)	0.031 (0.17)	R-33.3 (5.86)	0.030 (0.17)
R-35.8 (6.30)	R-38.6 (6.80)	R-34.3 (6.03)*	0.029 (0.17)*	R-35.5 (6.26)*	0.028 (0.16)*	R-36.2 (6.38)*	0.028 (0.16)*
R-39.0 (6.87)	R-41.9 (7.37)	R-36.9 (6.50)	0.027 (0.15)	R-38.4 (6.76)	0.026 (0.15)	R-39.2 (6.90)	0.026 (0.14)

*Indicates interpolated value

Detail 7.1.22

Exterior Insulated Concrete Block Wall Assembly with SOPREMA SOPRA-ISO V ALU and ACS-S Thermal Clip (24" o.c. Horizontal) Supporting Metal Cladding - Clear Wall

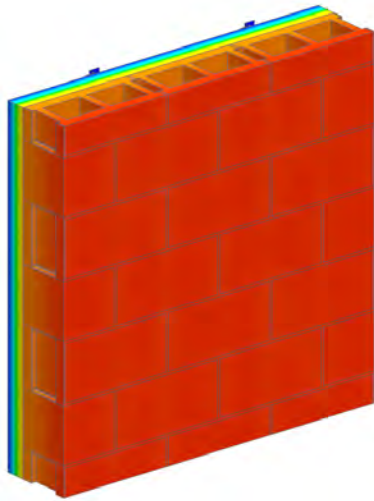

View from Interior

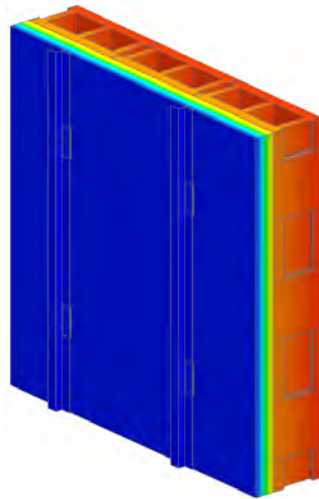

View from Exterior



Thermal Performance Indicators

Assembly 1D (Nominal) R-Value	R_{1D}	R-2.87 (0.51 RSI) + exterior insulation
Transmittance / Resistance	U_o / R_o	"Clear wall" U- and R-value

Nominal (1D) vs. Assembly Performance Indicators

Exterior Insulation 1D R-value (RSI)	R_{1D} ft ² ·hr·°F / Btu (m ² K / W)	24" Vertical Spacing		36" Vertical Spacing		48" Vertical Spacing	
		R_o ft ² ·hr·°F / Btu (m ² K / W)	U_o Btu/ft ² ·hr ·°F (W/m ² K)	R_o ft ² ·hr·°F / Btu (m ² K / W)	U_o Btu/ft ² ·hr ·°F (W/m ² K)	R_o ft ² ·hr·°F / Btu (m ² K / W)	U_o Btu/ft ² ·hr ·°F (W/m ² K)
R-6.5 (1.14)	R-9.4 (1.65)	R-9.1 (1.59)	0.110 (0.63)	R-9.1 (1.60)	0.110 (0.63)	R-9.1 (1.60)	0.110 (0.63)
R-13.0 (2.29)	R-15.9 (2.79)	R-15.1 (2.66)*	0.066 (0.38)*	R-15.3 (2.69)*	0.065 (0.37)*	R-15.4 (2.70)*	0.065 (0.37)*
R-16.3 (2.86)	R-19.1 (3.37)	R-18.1 (3.19)*	0.055 (0.31)*	R-18.4 (3.23)*	0.054 (0.31)*	R-18.5 (3.25)*	0.054 (0.31)*
R-19.5 (3.43)	R-22.4 (3.94)	R-21.1 (3.72)	0.047 (0.27)	R-21.4 (3.77)	0.047 (0.26)	R-21.6 (3.80)	0.046 (0.26)
R-22.8 (4.01)	R-25.6 (4.51)	R-24.0 (4.23)*	0.042 (0.24)*	R-24.5 (4.31)*	0.041 (0.23)*	R-24.7 (4.34)*	0.041 (0.23)*
R-26.0 (4.58)	R-28.9 (5.08)	R-27.0 (4.75)	0.037 (0.21)	R-27.5 (4.84)	0.036 (0.21)	R-27.8 (4.89)	0.036 (0.20)
R-29.3 (5.15)	R-32.1 (5.66)	R-29.8 (5.25)*	0.034 (0.19)*	R-30.5 (5.37)*	0.033 (0.19)*	R-30.8 (5.43)*	0.032 (0.18)*
R-32.5 (5.72)	R-35.4 (6.23)	R-32.6 (5.75)	0.031 (0.17)	R-33.4 (5.88)	0.030 (0.17)	R-33.8 (5.96)	0.030 (0.17)
R-35.8 (6.30)	R-38.6 (6.80)	R-35.5 (6.26)*	0.028 (0.16)*	R-36.4 (6.41)*	0.027 (0.16)*	R-36.9 (6.50)*	0.027 (0.15)*
R-39.0 (6.87)	R-41.9 (7.37)	R-38.4 (6.76)	0.026 (0.15)	R-39.4 (6.93)	0.025 (0.14)	R-40.0 (7.04)	0.025 (0.14)

*Indicates interpolated value

Detail 7.1.23

Exterior Insulated Concrete Block Wall Assembly with Mineral Wool and ACS-S Thermal Clip (16" o.c. Horizontal) Supporting Metal Cladding - Clear Wall

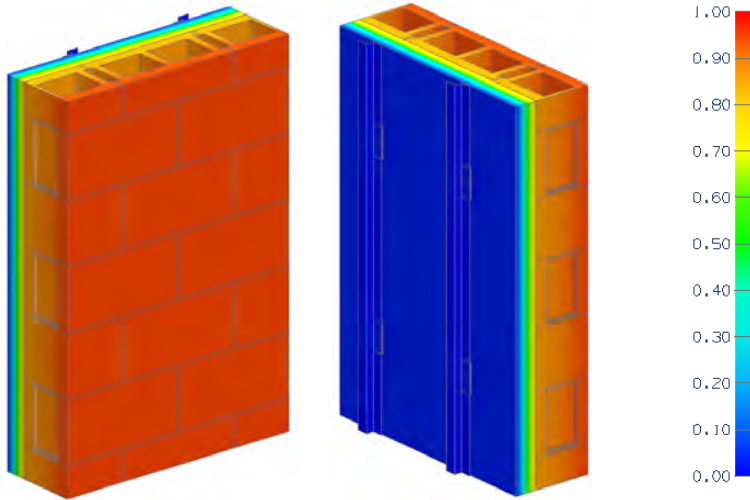

View from Interior View from Exterior

Thermal Performance Indicators

Assembly 1D (Nominal) R-Value	R_{1D}	R-2.87 (0.51 RSI) + exterior insulation
Transmittance / Resistance	U_o , R_o	"Clear wall" U- and R-value

Nominal (1D) vs. Assembly Performance Indicators

Exterior Insulation 1D R-value (RSI)	R_{1D} ft ² ·hr·°F / Btu (m ² K / W)	24" Vertical Spacing		36" Vertical Spacing		48" Vertical Spacing	
		R_o ft ² ·hr·°F / Btu (m ² K / W)	U_o Btu/ft ² ·hr ·°F (W/m ² K)	R_o ft ² ·hr·°F / Btu (m ² K / W)	U_o Btu/ft ² ·hr ·°F (W/m ² K)	R_o ft ² ·hr·°F / Btu (m ² K / W)	U_o Btu/ft ² ·hr ·°F (W/m ² K)
R-12.9 (2.27)	R-15.8 (2.78)	R-14.8 (2.61)	0.068 (0.38)	R-15.0 (2.65)	0.067 (0.38)	R-15.2 (2.67)	0.066 (0.37)
R-17.2 (3.03)	R-20.1 (3.53)	R-18.6 (3.28)*	0.054 (0.31)*	R-19.0 (3.34)*	0.053 (0.30)*	R-19.2 (3.38)*	0.052 (0.30)*
R-21.5 (3.79)	R-24.4 (4.29)	R-22.4 (3.94)	0.045 (0.25)	R-22.9 (4.04)	0.044 (0.25)	R-23.2 (4.09)	0.043 (0.24)
R-25.8 (4.54)	R-28.7 (5.05)	R-26.1 (4.60)	0.038 (0.22)	R-26.9 (4.73)	0.037 (0.21)	R-27.3 (4.80)	0.037 (0.21)
R-30.1 (5.30)	R-33.0 (5.81)	R-29.8 (5.24)	0.034 (0.19)	R-30.7 (5.40)	0.033 (0.19)	R-31.2 (5.49)	0.032 (0.18)
R-34.4 (6.06)	R-37.3 (6.56)	R-33.5 (5.90)	0.030 (0.17)	R-34.6 (6.09)	0.029 (0.16)	R-35.2 (6.20)	0.028 (0.16)

*Indicates interpolated value

Detail 7.1.24

Exterior Insulated Concrete Block Wall Assembly with Mineral Wool and ACS-S Thermal Clip (24" o.c. Horizontal) Supporting Metal Cladding - Clear Wall

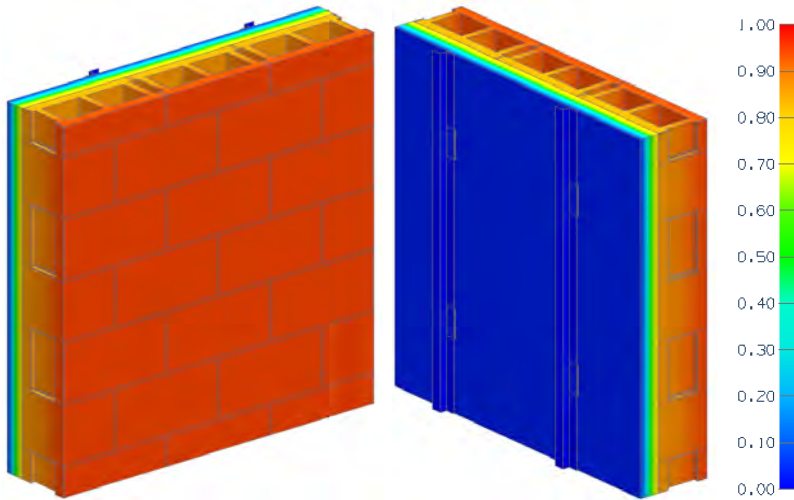

View from Interior

View from Exterior

Thermal Performance Indicators

Assembly 1D (Nominal) R-Value	R_{1D}	R-2.87 (0.51 RSI) + exterior insulation
Transmittance / Resistance	U_o / R_o	"Clear wall" U- and R-value

Nominal (1D) vs. Assembly Performance Indicators

Exterior Insulation 1D R-value (RSI)	R_{1D} ft ² ·hr·°F / Btu (m ² K / W)	24" Vertical Spacing		36" Vertical Spacing		48" Vertical Spacing	
		R_o ft ² ·hr·°F / Btu (m ² K / W)	U_o Btu/ft ² ·hr ·°F (W/m ² K)	R_o ft ² ·hr·°F / Btu (m ² K / W)	U_o Btu/ft ² ·hr ·°F (W/m ² K)	R_o ft ² ·hr·°F / Btu (m ² K / W)	U_o Btu/ft ² ·hr ·°F (W/m ² K)
R-12.9 (2.27)	R-15.8 (2.78)	R-15.0 (2.65)	0.066 (0.38)	R-15.2 (2.68)	0.066 (0.37)	R-15.3 (2.69)	0.065 (0.37)
R-17.2 (3.03)	R-20.1 (3.53)	R-19.0 (3.35)*	0.053 (0.30)*	R-19.3 (3.39)*	0.052 (0.29)*	R-19.4 (3.42)*	0.052 (0.29)*
R-21.5 (3.79)	R-24.4 (4.29)	R-22.9 (4.04)	0.044 (0.25)	R-23.3 (4.11)	0.043 (0.24)	R-23.5 (4.14)	0.043 (0.24)
R-25.8 (4.54)	R-28.7 (5.05)	R-26.9 (4.73)	0.037 (0.21)	R-27.3 (4.82)	0.037 (0.21)	R-27.6 (4.87)	0.036 (0.21)
R-30.1 (5.30)	R-33.0 (5.81)	R-30.7 (5.41)	0.033 (0.19)	R-31.3 (5.52)	0.032 (0.18)	R-31.7 (5.58)	0.032 (0.18)
R-34.4 (6.06)	R-37.3 (6.56)	R-34.6 (6.09)	0.029 (0.16)	R-35.4 (6.23)	0.028 (0.16)	R-35.8 (6.30)	0.028 (0.16)

*Indicates interpolated value

Detail 7.1.25

Exterior Insulated Concrete Block Wall Assembly with Protected SOPREMA SOPRA-ISO V ALU and ACS-S Thermal Clip (16" o.c. Horizontal) Supporting Metal Cladding - Clear Wall

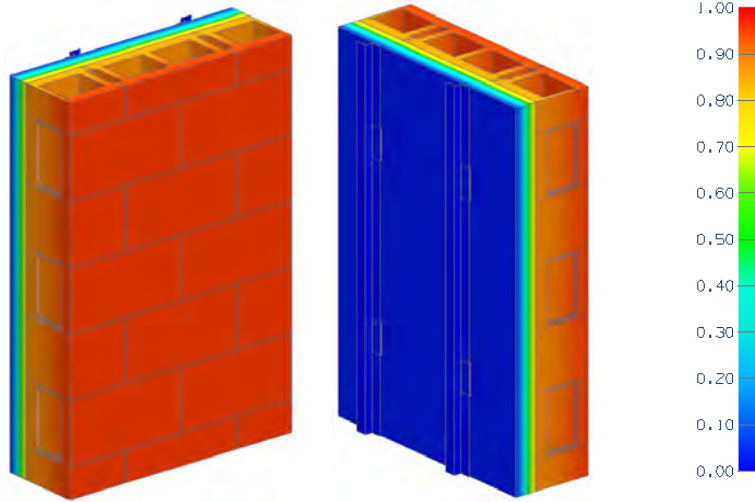

View from Interior View from Exterior

Thermal Performance Indicators

Assembly 1D (Nominal) R-Value	R_{1D}	R-2.9 (0.51 RSI) + exterior insulation
Transmittance / Resistance	U_o , R_o	"Clear wall" U- and R-value

Nominal (1D) vs. Assembly Performance Indicators

Exterior Insulation 1D R-value (RSI)	R_{1D} ft ² ·hr·°F / Btu (m ² K / W)	24" Vertical Spacing		36" Vertical Spacing		48" Vertical Spacing	
		R_o ft ² ·hr·°F / Btu (m ² K / W)	U_o Btu/ft ² ·hr ·°F (W/m ² K)	R_o ft ² ·hr·°F / Btu (m ² K / W)	U_o Btu/ft ² ·hr ·°F (W/m ² K)	R_o ft ² ·hr·°F / Btu (m ² K / W)	U_o Btu/ft ² ·hr ·°F (W/m ² K)
R-15.1 (2.66)	R-18.0 (3.16)	R-17.0 (2.99)	0.059 (0.33)	R-17.2 (3.04)	0.058 (0.33)	R-17.4 (3.06)	0.058 (0.33)
R-18.4 (3.23)	R-21.2 (3.74)	R-19.8 (3.49)*	0.050 (0.29)*	R-20.2 (3.56)*	0.050 (0.28)*	R-20.4 (3.59)*	0.049 (0.28)*
R-21.6 (3.80)	R-24.5 (4.31)	R-22.6 (3.99)	0.044 (0.25)	R-23.2 (4.08)	0.043 (0.25)	R-23.4 (4.12)	0.043 (0.24)
R-24.9 (4.38)	R-27.7 (4.88)	R-25.4 (4.47)*	0.039 (0.22)*	R-26.1 (4.59)*	0.038 (0.22)*	R-26.4 (4.65)*	0.038 (0.22)*
R-28.1 (4.95)	R-31.0 (5.45)	R-28.1 (4.95)	0.036 (0.20)	R-28.9 (5.10)	0.035 (0.20)	R-29.4 (5.17)	0.034 (0.19)
R-31.4 (5.52)	R-34.2 (6.03)	R-30.9 (5.44)*	0.032 (0.18)*	R-31.9 (5.61)*	0.031 (0.18)*	R-32.4 (5.70)*	0.031 (0.18)*
R-34.6 (6.09)	R-37.5 (6.60)	R-33.6 (5.92)	0.030 (0.17)	R-34.7 (6.12)	0.029 (0.16)	R-35.3 (6.22)	0.028 (0.16)
R-37.9 (6.67)	R-40.7 (7.17)	R-36.3 (6.38)*	0.028 (0.16)*	R-37.6 (6.62)*	0.027 (0.15)*	R-38.3 (6.74)*	0.026 (0.15)*
R-41.1 (7.24)	R-44.0 (7.74)	R-38.9 (6.85)	0.026 (0.15)	R-40.4 (7.12)	0.025 (0.14)	R-41.2 (7.26)	0.024 (0.14)

*Indicates interpolated value

Detail 7.1.26

Exterior Insulated Concrete Block Wall Assembly with Protected SOPREMA SOPRA-ISO V ALU and ACS-S Thermal Clip (24" o.c. Horizontal) Supporting Metal Cladding - Clear Wall

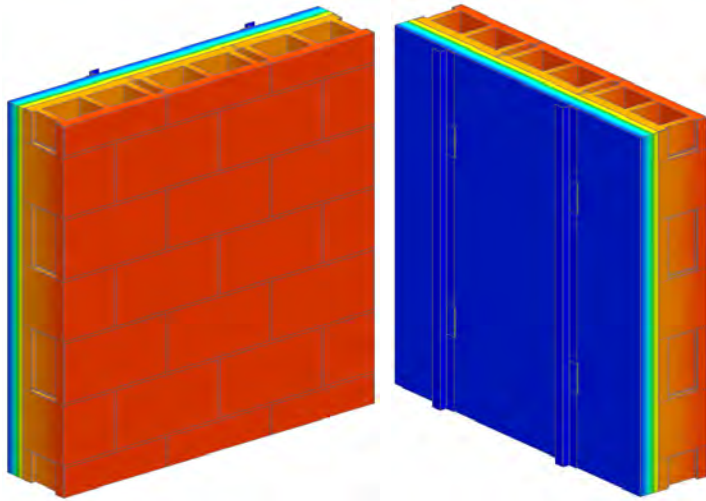

Thermal Performance Indicators

Assembly 1D (Nominal) R-Value	R_{1D}	R-2.9 (0.51 RSI) + exterior insulation
Transmittance / Resistance	U_o , R_o	"Clear wall" U- and R-value

View from Interior

View from Exterior

Nominal (1D) vs. Assembly Performance Indicators

Exterior Insulation 1D R-value (RSI)	R_{1D} ft ² ·hr·°F / Btu (m ² K / W)	24" Vertical Spacing		36" Vertical Spacing		48" Vertical Spacing	
		R_o ft ² ·hr·°F / Btu (m ² K / W)	U_o Btu/ft ² ·hr ·°F (W/m ² K)	R_o ft ² ·hr·°F / Btu (m ² K / W)	U_o Btu/ft ² ·hr ·°F (W/m ² K)	R_o ft ² ·hr·°F / Btu (m ² K / W)	U_o Btu/ft ² ·hr ·°F (W/m ² K)
R-15.1 (2.66)	R-18.0 (3.16)	R-17.2 (3.04)	0.058 (0.33)	R-17.4 (3.07)	0.057 (0.33)	R-17.5 (3.09)	0.057 (0.32)
R-18.4 (3.23)	R-21.2 (3.74)	R-20.2 (3.56)*	0.050 (0.28)*	R-20.5 (3.61)*	0.049 (0.28)*	R-20.6 (3.63)*	0.049 (0.28)*
R-21.6 (3.80)	R-24.5 (4.31)	R-23.2 (4.08)	0.043 (0.25)	R-23.5 (4.14)	0.043 (0.24)	R-23.7 (4.17)	0.042 (0.24)
R-24.9 (4.38)	R-27.7 (4.88)	R-26.1 (4.59)*	0.038 (0.22)*	R-26.5 (4.67)*	0.038 (0.21)*	R-26.8 (4.72)*	0.037 (0.21)*
R-28.1 (4.95)	R-31.0 (5.45)	R-28.9 (5.10)	0.035 (0.20)	R-29.5 (5.20)	0.034 (0.19)	R-29.8 (5.25)	0.034 (0.19)
R-31.4 (5.52)	R-34.2 (6.03)	R-31.9 (5.61)*	0.031 (0.18)*	R-32.6 (5.73)*	0.031 (0.17)*	R-32.9 (5.80)*	0.030 (0.17)*
R-34.6 (6.09)	R-37.5 (6.60)	R-34.7 (6.12)	0.029 (0.16)	R-35.6 (6.27)	0.028 (0.16)	R-36.0 (6.34)	0.028 (0.16)
R-37.9 (6.67)	R-40.7 (7.17)	R-37.6 (6.62)*	0.027 (0.15)*	R-38.5 (6.79)*	0.026 (0.15)*	R-39.0 (6.87)*	0.026 (0.15)*
R-41.1 (7.24)	R-44.0 (7.74)	R-40.4 (7.12)	0.025 (0.14)	R-41.5 (7.31)	0.024 (0.14)	R-42.0 (7.40)	0.024 (0.14)

*Indicates interpolated value

Detail 7.1.27

Exterior Insulated Concrete Mass Wall with 1 5/8" x 1 5/8" Steel Stud (16" o.c.) and Thermally Isolated Vertical Brackets and Rail System (24" o.c.) Supporting Metal Cladding – Clear Wall

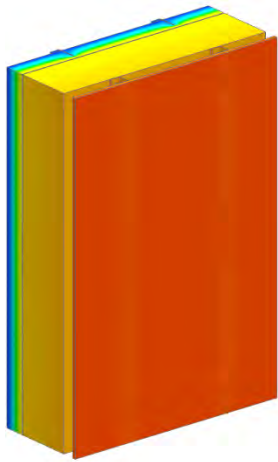

View from Interior

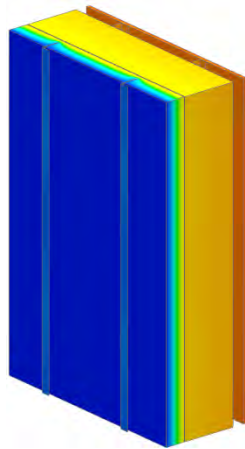

View from Exterior



Thermal Performance Indicators

Assembly 1D (Nominal) R-Value	R_{1D}	R-3.4 (0.59 RSI) + exterior insulation
Transmittance / Resistance without Anomaly	U_o, R_o	"clear wall" U- and R-value

Nominal (1D) vs. Assembly Performance Indicators

Exterior Insulation 1D R-Value (RSI)	R_{1D} ft ² ·hr·°F / Btu (m ² K / W)	R_o ft ² ·hr·°F / Btu (m ² K / W)	U_o Btu/ft ² ·hr·°F (W/m ² K)
R-10 (1.76)	R-13.4 (2.35)	R-10.9 (1.92)	0.092 (0.52)
R-15 (2.64)	R-18.4 (3.23)	R-13.3 (2.34)	0.075 (0.43)
R-20 (3.52)	R-23.4 (4.11)	R-15.9 (2.80)	0.063 (0.36)
R-25 (4.40)	R-28.4 (4.99)	R-18.3 (3.22)	0.055 (0.31)

Detail 7.2.1

Exterior Insulated Concrete Drained EIFS Wall Assembly – Intermediate Floor Intersection

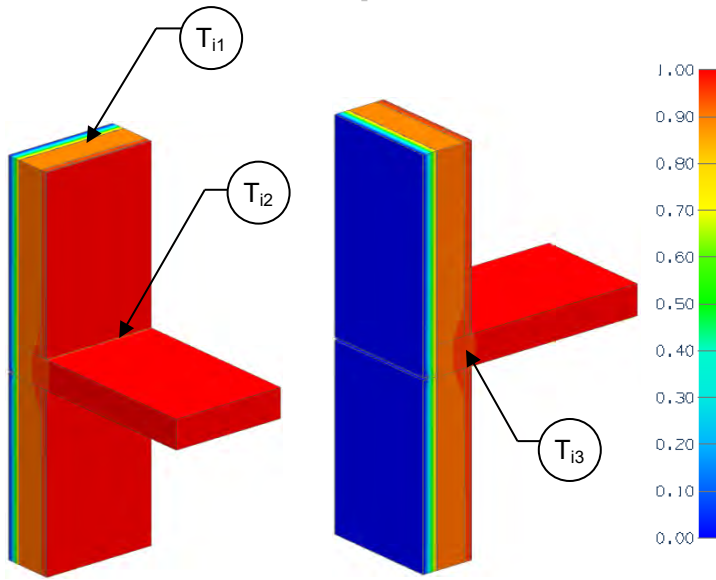

Thermal Performance Indicators

Assembly 1D (Nominal) R-Value	R _{1D}	R-3.0 (0.53 RSI) + exterior insulation
Transmittance / Resistance without Anomaly	U _o , R _o	“clear wall” U- and R-value without slab
Transmittance / Resistance	U, R	U- and R-values for overall assembly
Surface Temperature Index ¹	T _i	0 = exterior temperature 1 = interior temperature
Linear Transmittance	ψ	Incremental increase in transmittance per linear length of slab

¹Assumptions and limitations for surface temperatures identified in ASHRAE 1365-RP

View from Interior

View from Exterior

Nominal (1D) vs. Assembly Performance Indicators

Exterior Insulation 1D R-Value (RSI)	R _{1D} ft ² ·hr·°F / Btu (m ² K / W)	R _o ft ² ·hr·°F / Btu (m ² K / W)	U _o Btu/ft ² ·hr ·°F (W/m ² K)	R ft ² ·hr·°F / Btu (m ² K / W)	U Btu/ft ² ·hr ·°F (W/m ² K)	ψ Btu/ft ·hr ·°F (W/m K)
R-15 (2.64)	R-18.0 (3.17)	R-17.6 (3.10)	0.057 (0.32)	R-17.1 (3.02)	0.058 (0.33)	0.013 (0.023)

Temperature Indices

T _{i1}	0.89	Min T on concrete wall, between studs away from floor slab
T _{i2}	0.92	Max T on concrete, along steel track of floor slab
T _{i3}	0.94	Min T on slab, at edge interior drywall, exposed to interior air

Detail 7.2.2

Interior Insulated Concrete Mass Wall with 1 5/8" Steel Stud (16" o.c.) Supporting Interior Finish – Non-Insulated Interior Wall and Non-insulated Intermediate Floor Intersection

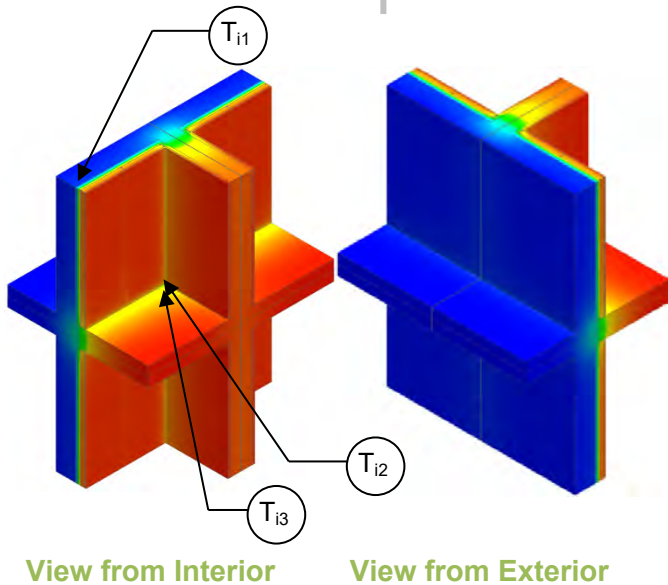

Thermal Performance Indicators

Assembly 1D (Nominal) R-Value	R_{1D}	Nominal thermal resistance of exterior wall
Transmittance / Resistance without Anomaly	U_o, R_o	"clear wall" U- and R-value of just concrete wall and steel stud assembly
Transmittance / Resistance	U_s, R_s, U_i, R_i	U and R-values for: s = concrete wall + slab i = concrete wall + interior wall
Transmittance / Resistance	U, R	U- and R-values for overall assembly
Surface Temperature Index ¹	T_i	0 = exterior temperature 1 = interior temperature
Linear Transmittance	ψ_s, ψ_i	Incremental increase in transmittance per linear length of: s = slab i = interior wall
Point Transmittance	χ	Incremental increase in transmittance for inner wall and slab intersection

¹Assumptions and limitations for surface temperatures identified in ASHRAE 1365-RP

Nominal (1D) vs. Assembly Performance Indicators

Base Assembly – Wall

R_{1D} ft ² ·hr·°F / Btu (m ² K / W)	R_o ft ² ·hr·°F / Btu (m ² K / W)	U_o Btu/ft ² ·hr ·°F (W/m ² K)
R-13.9 (2.44)	R-13.5 (2.37)	0.074 (0.42)

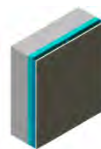

Slab Linear Transmittance

R_s ft ² ·hr·°F / Btu (m ² K / W)	U_s Btu/ft ² ·hr ·°F (W/m ² K)	ψ_s Btu/ft hr °F (W/m K)
R-7.0 (1.22)	0.144 (0.82)	0.465 (0.805)

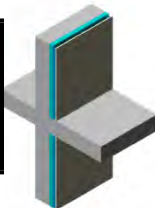

Interior Linear Transmittance

R_i ft ² ·hr·°F / Btu (m ² K / W)	U_i Btu/ft ² ·hr ·°F (W/m ² K)	ψ_i Btu/ft hr °F (W/m K)
R-7.4 (1.30)	0.135 (0.77)	0.385 (0.666)

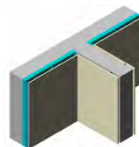

Intersection Point Transmittance

R ft ² ·hr·°F / Btu (m ² K / W)	U Btu/ft ² ·hr ·°F (W/m ² K)	χ^2 Btu/ft hr °F (W/K)
R-4.4 (0.77)	0.228 (1.30)	-0.48 (-0.25)

²Values are negative for a correction factor. See section 6 in ASHRAE 1365-RP for clarification.

Temperature Indices

T_{i1}	0.06	Min T on concrete wall, between studs, away from wall and slab
T_{i2}	0.35	Max T on concrete wall, at corner intersection
T_{i3}	0.59	Min T on interior surface, at corner intersection

Detail 7.2.3

Interior Insulated Concrete Mass Wall with 1 5/8" Steel Stud (16" o.c.) Supporting Interior Finish – Insulated Interior Wall and Non-insulated Intermediate Floor Intersection

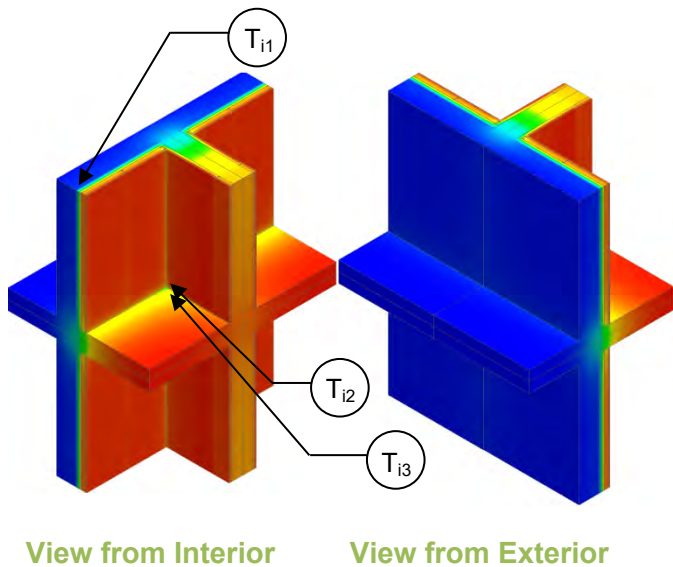

Thermal Performance Indicators

Assembly 1D (Nominal) R-Value	R_{1D}	Nominal thermal resistance of exterior wall
Transmittance / Resistance without Anomaly	U_o, R_o	"clear wall" U- and R-value of just concrete wall and steel stud assembly
Transmittance / Resistance	U_s, R_s, U_i, R_i	U and R values for: s = concrete wall + slab i = concrete wall + interior wall
Transmittance / Resistance	U, R	U- and R-values for overall assembly
Surface Temperature Index ¹	T_i	0 = exterior temperature 1 = interior temperature
Linear Transmittance	ψ_s, ψ_i	Incremental increase in transmittance per linear length of: s = slab i = interior wall
Point Transmittance	χ	Incremental increase in transmittance for inner wall and slab intersection

¹Assumptions and limitations for surface temperatures identified in ASHRAE 1365-RP

Nominal (1D) vs. Assembly Performance Indicators

Base Assembly – Wall

R_{1D} ft ² ·hr·°F / Btu (m ² K / W)	R_o ft ² ·hr·°F / Btu (m ² K / W)	U_o Btu/ft ² ·hr ·°F (W/m ² K)
R-13.9 (2.44)	R-13.5 (2.37)	0.074 (0.42)



Slab Linear Transmittance

R_s ft ² ·hr·°F / Btu (m ² K / W)	U_s Btu/ft ² ·hr ·°F (W/m ² K)	ψ_s Btu/ft hr °F (W/m K)
R-7.0 (1.22)	0.144 (0.82)	0.465 (0.805)



Interior Wall Linear Transmittance

R_i ft ² ·hr·°F / Btu (m ² K / W)	U_i Btu/ft ² ·hr ·°F (W/m ² K)	ψ_i Btu/ft hr °F (W/m K)
R-8.6 (1.52)	0.116 (0.66)	0.262 (0.454)

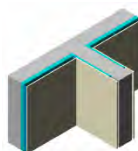

Intersection Point Transmittance

R ft ² ·hr·°F / Btu (m ² K / W)	U Btu/ft ² ·hr ·°F (W/m ² K)	χ^2 Btu/ft hr °F (W/K)
R-6.1 (1.07)	0.164 (0.93)	-0.29 (-0.16)

²Values are negative for a correction factor. See section 6 in ASHRAE-1365 RP for clarification.

Temperature Indices

Ti1	0.06	Min T on concrete wall between studs, away from wall and slab
Ti2	0.34	Max T on concrete wall, at corner intersection
Ti3	0.57	Min T on interior surface, at corner intersection

Detail 7.2.4

Interior Insulated Concrete Mass Wall with 3 5/8" x 1 5/8" Steel Studs (16" o.c.) Supporting Interior Finish – Interior Insulated Wall and Non-Insulated Partition Wall Intersection

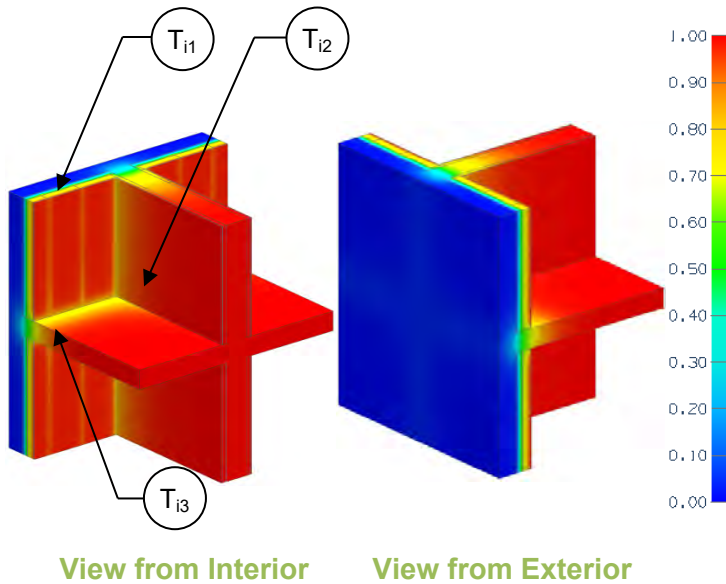

Thermal Performance Indicators

Assembly 1D (Nominal) R-Value	R_{1D}	R-14 (2.47 RSI) + interior insulation
Transmittance / Resistance without Anomaly	U_o, R_o	"clear wall" U- and R-value of just concrete wall and steel stud assembly
Transmittance / Resistance	$U_s, R_s, U_i, R_i, U_t, R_t$	U and R values for: s = concrete wall + slab i = concrete wall + interior wall t = combined concrete wall + slab + interior wall
Surface Temperature Index ¹	T_i	0 = exterior temperature 1 = interior temperature
Linear Transmittance	ψ_s, ψ_i	Incremental increase in transmittance per linear length of: s = slab i = interior wall
Point Transmittance	χ	Incremental increase in transmittance for inner wall and slab intersection

¹Assumptions and limitations for surface temperatures identified in ASHRAE 1365-RP

Nominal (1D) vs. Assembly Performance Indicators

Base Assembly – Wall

Interior Insulation 1D R-Value (RSI)	R_{1D} ft ² ·hr·°F / Btu (m ² K / W)	R_o ft ² ·hr·°F / Btu (m ² K / W)	U_o Btu/ft ² ·hr·°F (W/m ² K)
R-10 (1.76)	R-24.0 (4.23)	R-19.8 (3.49)	0.050 (0.29)
R-15 (2.64)	R-29.0 (5.11)	R-24.9 (4.38)	0.040 (0.23)

Slab Linear Transmittance

R_s ft ² ·hr·°F / Btu (m ² K / W)	U_s Btu/ft ² ·hr·°F (W/m ² K)	ψ_s Btu/ft·hr·°F (W/m K)
R-9.5 (1.67)	0.105 (0.60)	0.476 (0.824)
R-10.7 (1.89)	0.093 (0.53)	0.460 (0.797)

Interior Wall Linear Transmittance

Interior Insulation 1D R-Value (RSI)	R_i ft ² ·hr·°F / Btu (m ² K / W)	U_i Btu/ft ² ·hr·°F (W/m ² K)	ψ_i Btu/ft·hr·°F (W/m K)
R-10 (1.76)	R-10.4 (1.83)	0.097 (0.55)	0.360 (0.622)
R-15 (2.64)	R-10.8 (1.90)	0.093 (0.53)	0.410 (0.710)

Intersection Point Transmittance

R_t ft ² ·hr·°F / Btu (m ² K / W)	U_t Btu/ft ² ·hr·°F (W/m ² K)	χ^2 Btu/ft·hr·°F (W/K)
R-6.7 (1.19)	0.149 (0.84)	-0.184 (-0.098)
R-7.4 (1.30)	0.136 (0.77)	-0.670 (-0.353)

²Values are negative for a correction factor. See section 6 in ASHRAE-1365 RP for clarification.

Temperature Indices

	R10	R15	
T_{i1}	0.04	0.03	Min T on concrete wall, between studs, away from wall and slab
T_{i2}	0.29	0.27	Max T on concrete wall, at corner intersection
T_{i3}	0.27	0.27	Min T on slab, at exterior wall away from intersection

Detail 7.2.5

Interior Insulated Concrete Mass Wall with 1 5/8" x 1 5/8" Steel Studs (16" o.c.) Supporting Interior Finish – Continuous Concrete Intermediate Floor Intersection

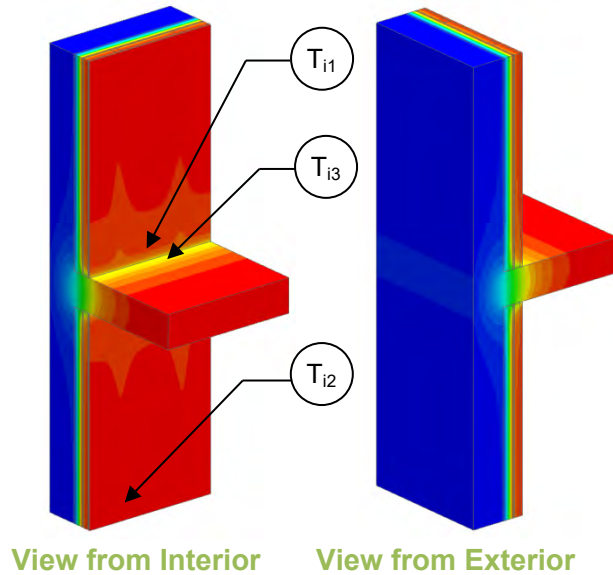

Thermal Performance Indicators

1.00	Assembly 1D (Nominal) R-Value	R_{1D}	R-2.9 (0.51 RSI) + interior insulation
0.90	Transmittance / Resistance without Anomaly	U_o, R_o	"clear wall" U- and R-value, without slab
0.80	Transmittance / Resistance	U, R	U and R-values for the assembly
0.70	Surface Temperature Index ¹	T_i	0 = exterior temperature 1 = interior temperature
0.60	Linear Transmittance	ψ	Incremental increase in transmittance per linear length of slab
0.50			
0.40			
0.30			
0.20			
0.10			
0.00			

¹Assumptions and limitations for surface temperatures identified in ASHRAE 1365-RP

Nominal (1D) vs. Assembly Performance Indicators

Exterior Insulation 1D R-Value (RSI)	R_{1D} ft ² ·hr·°F / Btu (m ² K / W)	R_o ft ² ·hr·°F / Btu (m ² K / W)	U_o Btu/ft ² ·hr·°F (W/m ² K)	R ft ² ·hr·°F / Btu (m ² K / W)	U Btu/ft ² ·hr·°F (W/m ² K)	ψ Btu/ft hr °F (W/m K)
R-12.5 (2.20)	R-15.4 (2.71)	R-15.4 (2.70)	0.065 (0.37)	R-8.1 (1.43)	0.123 (0.70)	0.500 (0.865)

Temperature Indices

T_{i1}	0.85	Min T on insulation away from slab, between studs
T_{i2}	0.87	Max T on insulation away from slab, at studs
T_{i3}	0.58	Min T on slab exposed to interior air, at insulation between studs

Detail 7.2.6

Precast Wall Assembly with 3 5/8" x 1 5/8" Steel Stud (16" o.c) and Insulation in Stud Cavity – Intermediate Floor Intersection

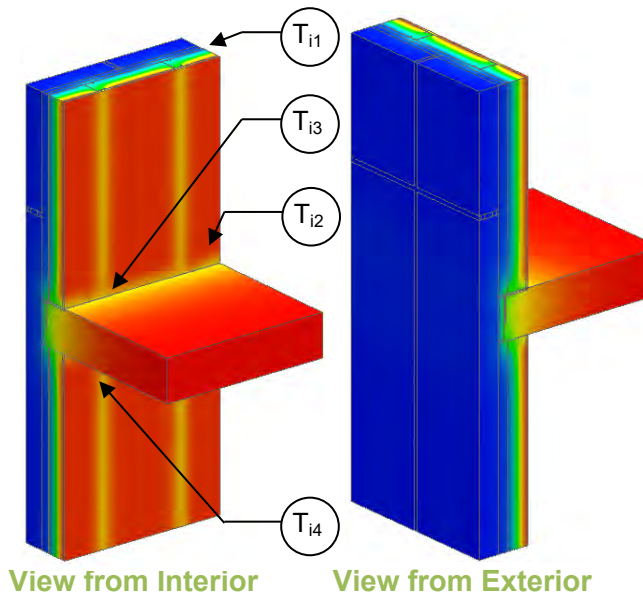

Thermal Performance Indicators

Assembly 1D (Nominal) R-Value	R_{1D}	Nominal thermal resistance of wall
Transmittance / Resistance without Anomaly	U_o, R_o	"clear wall" U- and R-value, without slab and anchor connections
Transmittance / Resistance	U, R	U- and R-values for overall assembly
Surface Temperature Index ¹	T_i	0 = exterior temperature 1 = interior temperature
Linear Transmittance	ψ	Incremental increase in transmittance per linear length of slab

¹Assumptions and limitations for surface temperatures identified in ASHRAE 1365-RP

Nominal (1D) vs. Assembly Performance Indicators

Base Assembly – Wall

R_{1D} ft ² ·hr·°F / Btu (m ² K / W)	R_o ft ² ·hr·°F / Btu (m ² K / W)	U_o Btu/ft ² ·hr ·°F (W/m ² K)
R-14.5 (2.55)	R-8.5 (1.49)	0.118 (0.67)

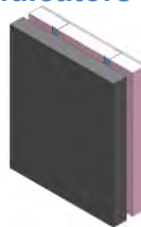

Slab Linear Transmittance²

R ft ² ·hr·°F / Btu (m ² K / W)	U Btu/ft ² ·hr ·°F (W/m ² K)	ψ Btu/ft hr °F (W/m K)
R-6.2 (1.09)	0.161 (0.91)	0.286 (0.495)

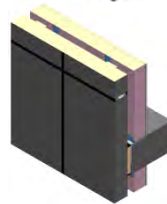

² Panel edges (caulked joints between panels) had negligible linear transmittance effects so values not presented

Temperature Indices

T_{i1}	0.05	Min T on concrete wall, between studs, away from slab
T_{i2}	0.23	Max T on concrete wall, at slot anchor
T_{i3}	0.73	Min T on floor, at gypsum and studs
T_{i4}	0.75	Min T on ceiling, at gypsum and studs

Detail 7.2.7

Precast Wall Assembly with 3 5/8" x 1 5/8" Steel Stud (16" o.c) and Rigid Insulation Outboard of Studs – Intermediate Floor Intersection

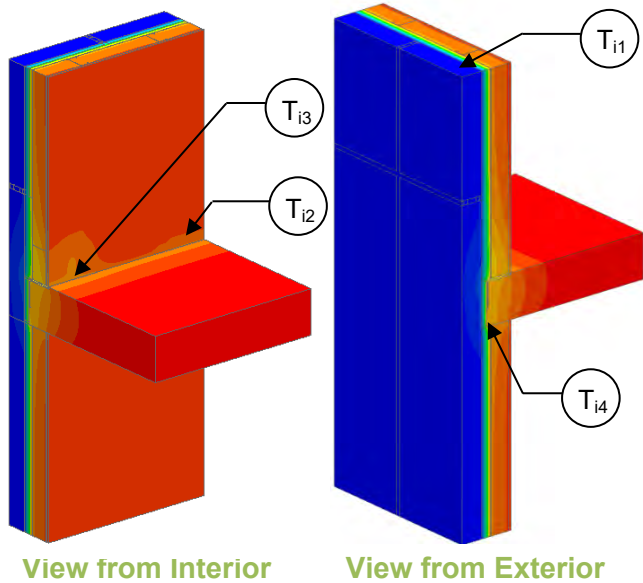

Thermal Performance Indicators

Assembly 1D (Nominal) R-Value	R_{1D}	Nominal thermal resistance of wall
Transmittance / Resistance without Anomaly	U_o, R_o	"clear wall" U- and R-value, without slab and anchor connections
Transmittance / Resistance	U, R	U- and R-values for overall assembly
Surface Temperature Index ¹	T_i	0 = exterior temperature 1 = interior temperature
Linear Transmittance	ψ	Incremental increase in transmittance per linear length of slab

¹Assumptions and limitations for surface temperatures identified in ASHRAE 1365-RP

Nominal (1D) vs. Assembly Performance Indicators

Base Assembly – Wall

R_{1D} ft ² ·hr·°F / Btu (m ² K / W)	R_o ft ² ·hr·°F / Btu (m ² K / W)	U_o Btu/ft ² ·hr·°F (W/m ² K)
R-13.0 (2.29)	R-12.9 (2.26)	0.078 (0.44)



Slab Linear Transmittance²

R ft ² ·hr·°F / Btu (m ² K / W)	U Btu/ft ² ·hr·°F (W/m ² K)	ψ Btu/ft hr °F (W/m K)
R-9.1 (1.60)	0.110 (0.63)	0.218 (0.377)

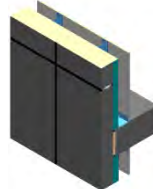

² Panel edges (caulked joints between panels) had negligible linear transmittance effects so values not presented

Temperature Indices

T_{i1}	0.04	Min T on concrete wall, between studs, away from slab
T_{i2}	0.31	Max T on concrete wall, at slot anchor connection
T_{i3}	0.80	Min T on floor, at gypsum and gravity anchor
T_{i4}	0.87	Min T on ceiling, at gypsum and studs

Detail 7.2.8

Precast Sandwich Panel Wall Assembly with 3 5/8" x 1 5/8" Steel Stud (16" o.c.) – Intermediate Floor Intersection

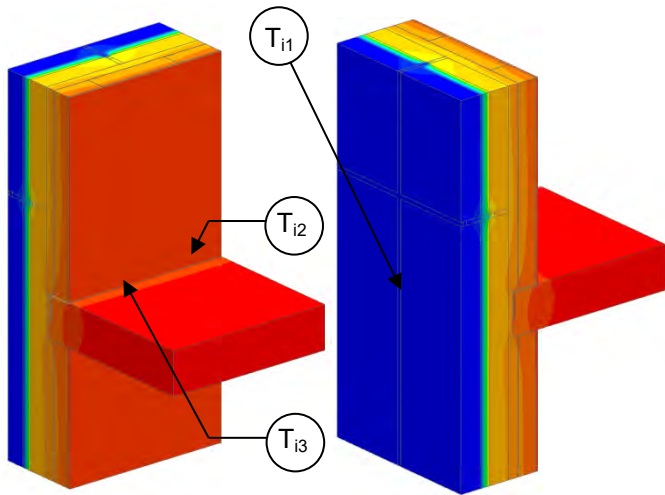

View from Interior

View from Exterior

Thermal Performance Indicators

Assembly 1D (Nominal) R-Value	R_{1D}	R-3.9 (0.69 RSI) + sandwich panel insulation
Transmittance / Resistance without Anomaly	U_o, R_o	“clear wall” U- and R-value without concrete slab
Transmittance / Resistance	U_j, R_j, U_s, R_s	U and R values for: j = concrete wall with panel joint f = concrete wall panel joint + concrete slab
Surface Temperature Index ¹	T_i	0 = exterior temperature 1 = interior temperature
Linear Transmittance	Ψ_j, Ψ_s	Incremental increase in transmittance per linear length of: j = panel joint s = concrete slab

¹Assumptions and limitations for surface temperatures identified in ASHRAE 1365-RP

Nominal (1D) vs. Assembly Performance Indicators

Base Assembly – Wall

R_{1D} ft ² ·hr·°F / Btu (m ² K / W)	R_o ft ² ·hr·°F / Btu (m ² K / W)	U_o Btu/ft ² ·hr ·°F (W/m ² K)
R-13.9 (2.45)	R-12.6 (2.22)	0.079 (0.45)



Panel Joint Linear Transmittance

R_j ft ² ·hr·°F / Btu (m ² K / W)	U_j Btu/ft ² ·hr ·°F (W/m ² K)	Ψ_j Btu/ft hr °F (W/m K)
R-11.7 (2.05)	0.086 (0.49)	0.026 (0.046)

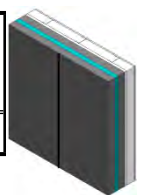

Slab Linear Transmittance

R_s ft ² ·hr·°F / Btu (m ² K / W)	U_s Btu/ft ² ·hr ·°F (W/m ² K)	Ψ_s Btu/ft hr °F (W/m K)
R-8.8 (1.54)	0.114 (0.65)	0.118 (0.205)

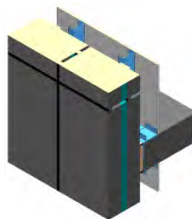

Temperature Indices

T_{i1}	0.73	Min T on interior concrete wall, at panel joints, at slab
T_{i2}	0.82	Max T on concrete wall, at slot anchor
T_{i3}	0.92	Min T in interior surface, at floor/gypsum intersection and anchor

Detail 7.2.9

Precast Sandwich Panel Wall Assembly with Concrete at Panel Perimeter and Steel Connectors at 24" o.c. – Intermediate Floor Intersection

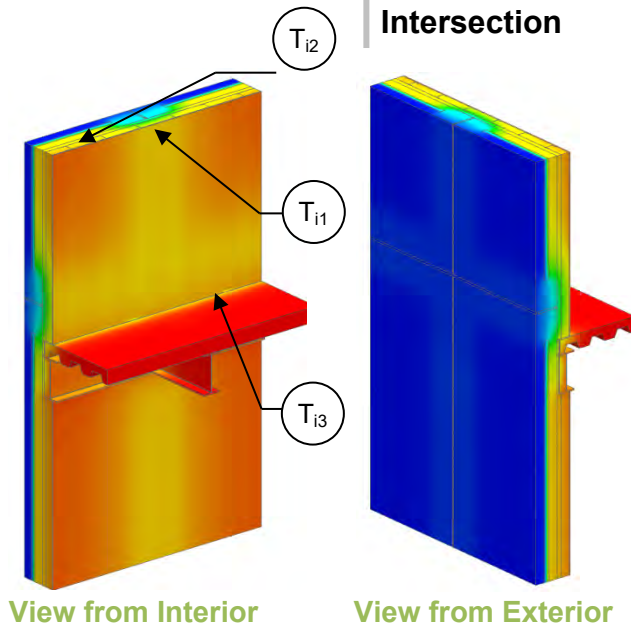

Thermal Performance Indicators

Assembly 1D (Nominal) R-Value	R_{1D}	R-3.9 (0.69 RSI) + sandwich panel insulation
Transmittance / Resistance without Anomaly	U_o, R_o	“clear wall” U- and R-value, without floor
Transmittance / Resistance	U_j, R_j, U_f, R_f	U and R values for: j = wall with panel joint f = concrete wall panel joint + floor
Surface Temperature Index ¹	T_i	0 = exterior temperature 1 = interior temperature
Linear Transmittance	ψ_j, ψ_f	Incremental increase in transmittance per linear length of: j = panel joint f = floor

¹Assumptions and limitations for surface temperatures identified in ASHRAE 1365-RP

Nominal (1D) vs. Assembly Performance Indicators

Base Assembly - Wall

Sandwich Panel Insulation 1D R-Value (RSI)	R_{1D} ft ² ·hr·°F / Btu (m ² K / W)	R_o ft ² ·hr·°F / Btu (m ² K / W)	U_o Btu/ft ² ·hr ·°F (W/m ² K)
R-10 (1.76)	R-13.9 (2.45)	R-12.0 (2.11)	0.083 (0.47)

Panel Joint Linear Transmittance

R_j ft ² ·hr·°F / Btu (m ² K / W)	U_j Btu/ft ² ·hr ·°F (W/m ² K)	ψ_j Btu/ft ·hr·°F (W/m K)
R-6.2 (1.10)	0.160 (0.91)	0.635 (1.130)

Floor Linear Transmittance

Sandwich Panel Insulation 1D R-Value (RSI)	R_f ft ² ·hr·°F / Btu (m ² K / W)	U_f Btu/ft ² ·hr ·°F (W/m ² K)	ψ_f Btu/ft ·hr·°F (W/m K)
R-10 (1.76)	R-4.7 (0.83)	0.213 (1.21)	0.738 (1.277)

Temperature Indices

T_{i1}	0.31	Min T on sandwich panel, at intersection of concrete edges
T_{i2}	0.83	Max T on sandwich panel, at centre of panel away from concrete edges
T_{i3}	0.77	Min T on slab, at drywall intersection near slab angle

Detail 7.2.10

Precast Sandwich Panel Wall Assembly with Steel Connectors at 16" o.c. – Intermediate Floor Intersection

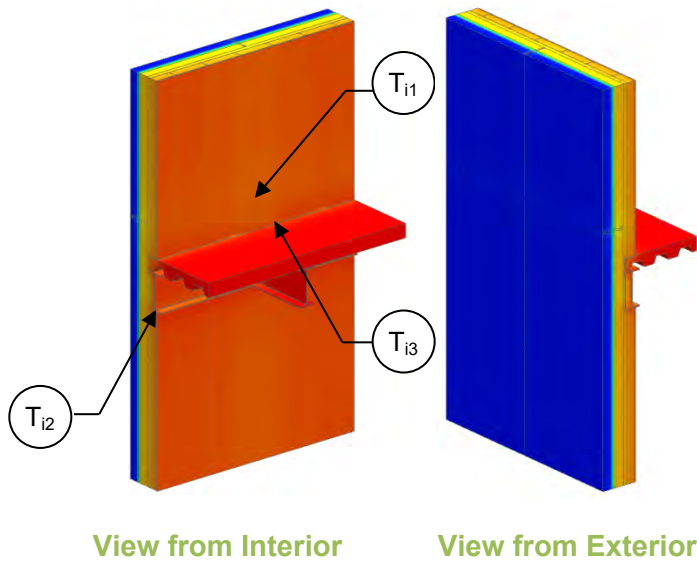

Thermal Performance Indicators

Assembly 1D (Nominal) R-Value	R_{1D}	R-3.9 (0.69 RSI) + sandwich panel insulation
Transmittance / Resistance without Anomaly	U_o, R_o	“clear wall” U- and R-value, without panel joints and floor
Transmittance / Resistance	U_j, R_j, U_f, R_f	U and R values for: j = concrete wall with panel joint f = concrete wall panel joint + floor
Surface Temperature Index ¹	T_i	0 = exterior temperature 1 = interior temperature
Linear Transmittance	Ψ_j, Ψ_f	Incremental increase in transmittance per linear length of: j = panel joint f = floor

¹Assumptions and limitations for surface temperatures identified in ASHRAE 1365-RP

Nominal (1D) vs. Assembly Performance Indicators

Base Assembly - Wall

Sandwich Panel Insulation 1D R-Value (RSI)	R_{1D} ft ² ·hr·°F / Btu (m ² K / W)	R_o ft ² ·hr·°F / Btu (m ² K / W)	U_o Btu/ft ² ·hr ·°F (W/m ² K)
R-10 (1.76)	R-13.9 (2.45)	R-12.0 (2.11)	0.083 (0.47)

Panel Joint Linear Transmittance

R_j ft ² ·hr·°F / Btu (m ² K / W)	U_j Btu/ft ² ·hr ·°F (W/m ² K)	Ψ_j Btu/ft ·hr·°F (W/m K)
R-11.6 (2.03)	0.087 (0.49)	0.026 (0.046)

Floor Linear Transmittance

Sandwich Panel Insulation 1D R-Value (RSI)	R_f ft ² ·hr·°F / Btu (m ² K / W)	U_f Btu/ft ² ·hr ·°F (W/m ² K)	Ψ_f Btu/ft ·hr·°F (W/m K)
R-10 (1.76)	R-11.2 (1.97)	0.089 (0.51)	0.039 (0.067)

Temperature Indices

T_{i1}	0.77	Min T on sandwich panel, at corner of sandwich panel
T_{i2}	0.88	Max T on sandwich panel, at centre of panel along top track of bottom wall
T_{i3}	0.93	Min T on slab, at drywall intersection near steel slab angle

Detail 7.2.11

Precast Sandwich Panel Wall Assembly with Steel Connectors at 36" o.c. – Intermediate Floor Intersection

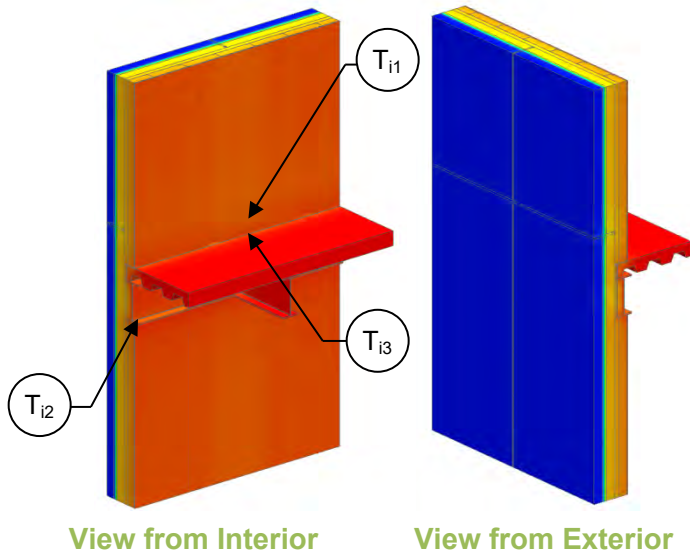

Thermal Performance Indicators

Assembly 1D (Nominal) R-Value	R_{1D}	R-3.9 (0.69 RSI) + sandwich panel insulation
Transmittance / Resistance without Anomaly	U_o, R_o	“clear wall” U- and R-value, without floor
Transmittance / Resistance	U_j, R_j, U_f, R_f	U and R values for: j = concrete wall with panel joint s = concrete wall panel joint + floor
Surface Temperature Index ¹	T_i	0 = exterior temperature 1 = interior temperature
Linear Transmittance	Ψ_j, Ψ_f	Incremental increase in transmittance per linear length of: j = panel joint f = floor

¹Assumptions and limitations for surface temperatures identified in ASHRAE 1365-RP

Nominal (1D) vs. Assembly Performance Indicators

Base Assembly - Wall

Sandwich Panel Insulation 1D R-Value (RSI)	R_{1D} ft ² ·hr·°F / Btu (m ² K / W)	R_o ft ² ·hr·°F / Btu (m ² K / W)	U_o Btu/ft ² ·hr ·°F (W/m ² K)
R-10 (1.76)	R-13.9 (2.45)	R-12.6 (2.22)	0.079 (0.45)

Panel Joint Linear Transmittance

R_j ft ² ·hr·°F / Btu (m ² K / W)	U_j Btu/ft ² ·hr ·°F (W/m ² K)	Ψ_j Btu/ft ·hr·°F (W/m K)
R-12.0 (2.11)	0.084 (0.48)	0.036 (0.062)

Floor Linear Transmittance

Sandwich Panel Insulation 1D R-Value (RSI)	R_f ft ² ·hr·°F / Btu (m ² K / W)	U_f Btu/ft ² ·hr ·°F (W/m ² K)	Ψ_f Btu/ft ·hr·°F (W/m K)
R-10 (1.76)	R-11.4 (2.00)	0.088 (0.50)	0.062 (0.107)

Temperature Indices

T_{i1}	0.77	Min T on sandwich panel, at corner of sandwich panel
T_{i2}	0.88	Max T on sandwich panel, at centre of panel at top track of bottom wall
T_{i3}	0.93	Min T on slab, at drywall intersection near steel slab angle

Detail 7.2.12

Precast Sandwich Panel Wall Assembly with Steel Connectors at 48" o.c. – Intermediate Floor Intersection

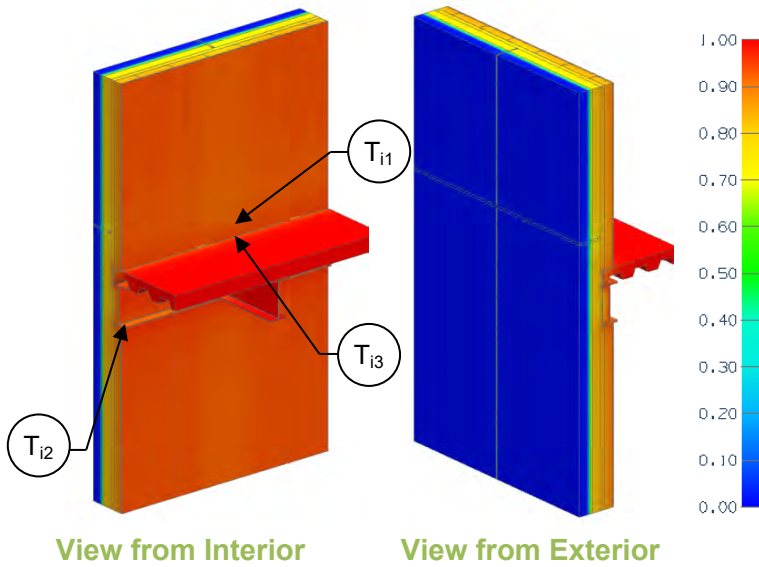

Thermal Performance Indicators

Assembly 1D (Nominal) R-Value	R_{1D}	R-3.9 (0.69 RSI) + sandwich panel insulation
Transmittance / Resistance without Anomaly	U_o, R_o	“clear wall” U- and R-value, without floor
Transmittance / Resistance	U_j, R_j, U_f, R_f	U and R values for: j = concrete wall with panel joint f = concrete wall panel joint + floor
Surface Temperature Index ¹	T_i	0 = exterior temperature 1 = interior temperature
Linear Transmittance	ψ_j, ψ_s	Incremental increase in transmittance per linear length of: j = panel joint f = floor

¹Assumptions and limitations for surface temperatures identified in ASHRAE 1365-RP

Nominal (1D) vs. Assembly Performance Indicators

Base Assembly

Sandwich Panel Insulation 1D R-Value (RSI)	R_{1D} ft ² ·hr·°F / Btu (m ² K / W)	R_o ft ² ·hr·°F / Btu (m ² K / W)	U_o Btu/ft ² ·hr ·°F (W/m ² K)
R-10 (1.76)	R-13.9 (2.45)	R-12.6 (2.22)	0.079 (0.45)

Panel Joint Linear Transmittance

R_j ft ² ·hr·°F / Btu (m ² K / W)	U_j Btu/ft ² ·hr ·°F (W/m ² K)	ψ_j Btu/ft ·hr·°F (W/m K)
R-12.1 (2.12)	0.083 (0.47)	0.030 (0.052)

Floor Linear Transmittance

Sandwich Panel Insulation 1D R-Value (RSI)	R_f ft ² ·hr·°F / Btu (m ² K / W)	U_f Btu/ft ² ·hr ·°F (W/m ² K)	ψ_f Btu/ft ·hr·°F (W/m K)
R-10 (1.76)	R-11.6 (2.05)	0.086 (0.49)	0.043 (0.074)

Temperature Indices

T_{i1}	0.78	Min T on sandwich panel, at corner of sandwich panels
T_{i2}	0.88	Max T on sandwich panel, at centre of panel along top track of bottom wall
T_{i3}	0.93	Min T on slab, at drywall intersection near steel slab angle

Detail 7.2.13

Precast Sandwich Panel Wall Assembly with Fiber-Reinforced Composite Connectors at 16" o.c. – Intermediate Floor Intersection

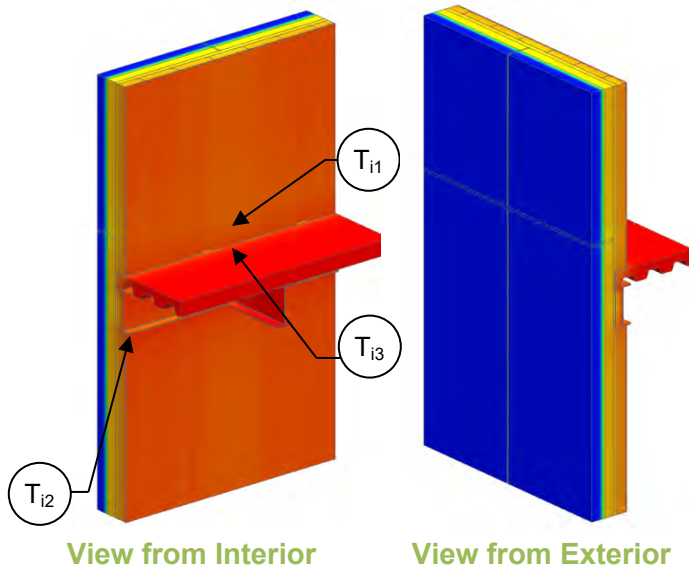

Thermal Performance Indicators

Assembly 1D (Nominal) R-Value	R_{1D}	R-3.9 (0.69 RSI) + sandwich panel insulation
Transmittance / Resistance without Anomaly	U_o, R_o	“clear wall” U- and R-value, without slab
Transmittance / Resistance	U, R	U and R-values for the assembly
Surface Temperature Index ¹	T_i	0 = exterior temperature 1 = interior temperature
Linear Transmittance	ψ	Incremental increase in transmittance per linear length steel framed floor

¹Assumptions and limitations for surface temperatures identified in ASHRAE 1365-RP

Nominal (1D) vs. Assembly Performance Indicators

Sandwich Panel Insulation 1D R-Value (RSI)	R_{1D} ft ² ·hr·°F / Btu (m ² K / W)	R_o ft ² ·hr·°F / Btu (m ² K / W)	U_o Btu/ft ² ·hr·°F (W/m ² K)	R ft ² ·hr·°F / Btu (m ² K / W)	U Btu/ft ² ·hr·°F (W/m ² K)	ψ Btu/ft·hr·°F (W/m K)
R-10 (1.76)	R-13.9 (2.45)	R-11.3 (1.99)	0.088 (0.50)	R-11.2 (1.98)	0.089 (0.51)	0.011 (0.018)

Temperature Indices

T_{i1}	0.77	Min T on sandwich panel, at corner of sandwich panels
T_{i2}	0.88	Max T on sandwich panel, at centre of panel along top track of bottom wall
T_{i3}	0.93	Min T on slab, at drywall intersection near steel slab angle

Detail 7.2.14

Exterior Insulated Concrete Block Wall Assembly with Shelf Angle & Brick Ties Supporting Brick Veneer – Intermediate Floor Intersection

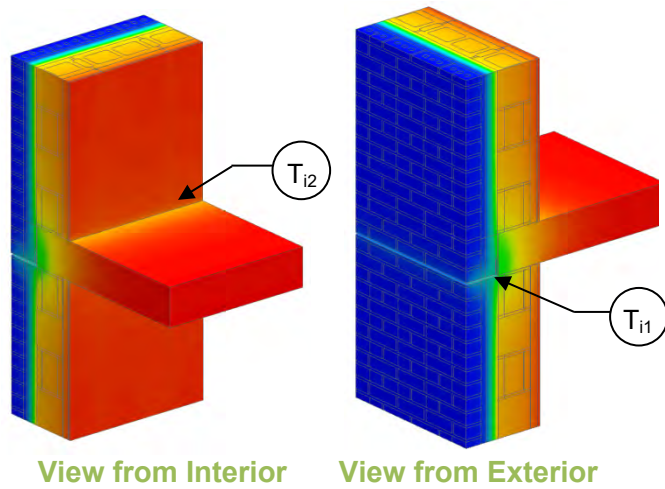

Thermal Performance Indicators

Assembly 1D (Nominal) R-Value	R_{1D}	R-5.6 (0.98 RSI) + exterior insulation
Transmittance / Resistance without Anomaly	U_o, R_o	“clear wall” U- and R-value without slab and shelf angle
Transmittance / Resistance	U, R	U- and R-values for overall assembly
Surface Temperature Index ¹	T_i	0 = exterior temperature 1 = interior temperature
Linear Transmittance	Ψ	Incremental increase in transmittance per linear length of shelf angle and slab

¹Assumptions and limitations for surface temperatures identified in ASHRAE 1365-RP

Nominal (1D) vs. Assembly Performance Indicators

Exterior Insulation 1D R-Value (RSI)	R_{1D} ft ² ·hr·°F / Btu (m ² K / W)	R_o ft ² ·hr·°F / Btu (m ² K / W)	U_o Btu/ft ² ·hr ·°F (W/m ² K)	R ft ² ·hr·°F / Btu (m ² K / W)	U Btu/ft ² ·hr ·°F (W/m ² K)	Ψ Btu/ft hr °F (W/m K)
R-5 (0.88)	R-10.6 (1.86)	R-10.4 (1.83)	0.096 (0.55)	R-7.4 (1.30)	0.135 (0.77)	0.236 (0.408)
R-10 (1.76)	R-15.6 (2.74)	R-14.2 (2.50)	0.070 (0.40)	R-8.8 (1.56)	0.113 (0.64)	0.258 (0.446)
R-15 (2.64)	R-20.6 (3.62)	R-17.8 (3.13)	0.056 (0.32)	R-9.9 (1.75)	0.101 (0.57)	0.268 (0.464)
R-20 (3.52)	R-25.6 (4.50)	R-20.8 (3.66)	0.048 (0.27)	R-10.8 (1.90)	0.093 (0.53)	0.270 (0.467)
R-25 (4.40)	R-30.6 (5.38)	R-23.7 (4.17)	0.042 (0.24)	R-11.5 (2.03)	0.087 (0.49)	0.268 (0.463)

Temperature Indices

	R5	R15	R25	
T_{i1}	0.47	0.51	0.57	Min T on exterior face of concrete blocks at air-filled blocks, at bottom of slab
T_{i2}	0.82	0.84	0.86	Min T on interior surfaces, at floor/gypsum intersection, at studs

Detail 7.2.15

Exterior Insulated Concrete Block Wall Assembly with Stand-Off Shelf Angle & Brick Ties Supporting Brick Veneer – Intermediate Floor Intersection

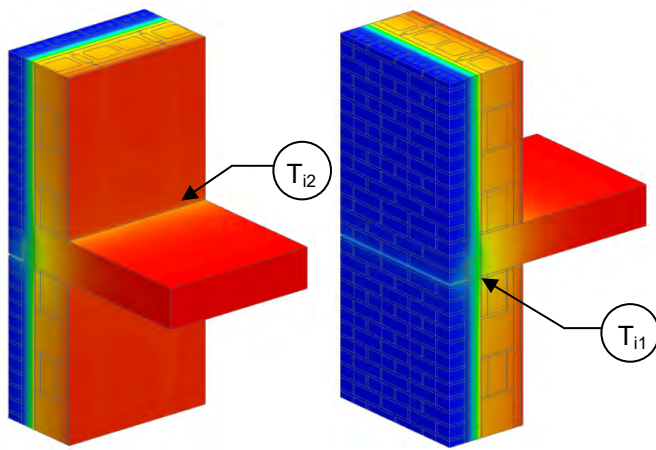

View from Interior View from Exterior

Thermal Performance Indicators

Assembly 1D (Nominal) R-Value	R_{1D}	R- 5.6 (0.98 RSI) + exterior insulation
Transmittance / Resistance without Anomaly	U_o, R_o	“clear wall” U- and R-value without slab and shelf angle
Transmittance / Resistance	U, R	U- and R-values for overall assembly
Surface Temperature Index ¹	T_i	0 = exterior temperature 1 = interior temperature
Linear Transmittance	ψ	Incremental increase in transmittance per linear length of shelf angle and slab

¹Assumptions and limitations for surface temperatures identified in ASHRAE 1365-RP

Nominal (1D) vs. Assembly Performance Indicators

Exterior Insulation 1D R-Value (RSI)	R_{1D} ft ² ·hr·°F / Btu (m ² K / W)	R_o ft ² ·hr·°F / Btu (m ² K / W)	U_o Btu/ft ² ·hr·°F (W/m ² K)	R ft ² ·hr·°F / Btu (m ² K / W)	U Btu/ft ² ·hr·°F (W/m ² K)	ψ Btu/ft hr °F (W/m K)
R-5 (0.88)	R-10.6 (1.86)	R-10.4 (1.83)	0.096 (0.55)	R-8.1 (1.42)	0.124 (0.70)	0.167 (0.289)
R-10 (1.76)	R-15.6 (2.74)	R-14.2 (2.50)	0.070 (0.40)	R-9.9 (1.74)	0.101 (0.57)	0.186 (0.322)
R-15 (2.64)	R-20.6 (3.62)	R-17.8 (3.13)	0.056 (0.32)	R-11.5 (2.02)	0.087 (0.49)	0.186 (0.322)
R-20 (3.52)	R-25.6 (4.50)	R-20.8 (3.66)	0.048 (0.27)	R-12.9 (2.27)	0.078 (0.44)	0.178 (0.307)
R-25 (4.40)	R-30.6 (5.38)	R-23.7 (4.17)	0.042 (0.24)	R-14.3 (2.51)	0.070 (0.40)	0.168 (0.290)

Temperature Indices

	R5	R15	R25	
T_{i1}	0.54	0.58	0.64	Min T on exterior face of concrete blocks, at air-filled blocks, at bottom of slab
T_{i2}	0.84	0.87	0.89	Min T on interior surfaces, on floor/gypsum intersection, at studs

Detail 7.2.16

Exterior Insulated Concrete Block Wall Assembly with Masonry Ties Supporting Brick Veneer – Intermediate Floor Intersection at Balcony

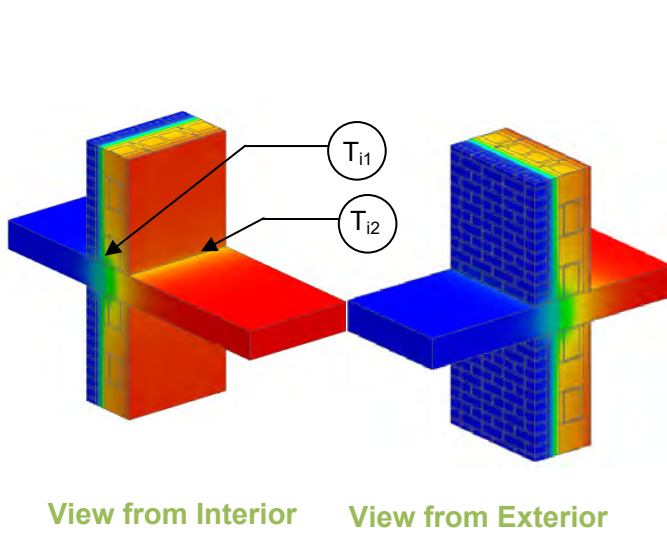

Thermal Performance Indicators

Assembly 1D (Nominal) R-Value	R_{1D}	R- 5.6 (0.98 RSI) + exterior insulation
Transmittance / Resistance without Anomaly	U_o R_o	“clear wall” U- and R-value without slab
Transmittance / Resistance	U, R	U- and R-values for overall assembly
Surface Temperature Index ¹	T_i	0 = exterior temperature 1 = interior temperature
Linear Transmittance	ψ	Incremental increase in transmittance per linear length of slab

¹Assumptions and limitations for surface temperatures identified in ASHRAE 1365-RP

Nominal (1D) vs. Assembly Performance Indicators

Exterior Insulation 1D R-Value (RSI)	R_{1D} ft ² ·hr·°F / Btu (m ² K / W)	R_o ft ² ·hr·°F / Btu (m ² K / W)	U_o Btu/ft ² ·hr·°F (W/m ² K)	R ft ² ·hr·°F / Btu (m ² K / W)	U Btu/ft ² ·hr·°F (W/m ² K)	ψ Btu/ft hr °F (W/m K)
R-5 (0.88)	R-10.6 (1.86)	R-10.4 (1.83)	0.096 (0.55)	R-6.64 (1.17)	0.151 (0.86)	0.327 (0.565)
R-10 (1.76)	R-15.6 (2.74)	R-14.2 (2.50)	0.070 (0.40)	R-7.77 (1.37)	0.129 (0.73)	0.350 (0.606)
R-15 (2.64)	R-20.6 (3.62)	R-17.8 (3.13)	0.056 (0.32)	R-8.71 (1.53)	0.155 (0.65)	0.352 (0.609)
R-20 (3.52)	R-25.6 (4.50)	R-20.8 (3.66)	0.048 (0.27)	R-9.43 (1.66)	0.106 (0.60)	0.348 (0.603)
R-25 (4.40)	R-30.6 (5.38)	R-23.7 (4.17)	0.042 (0.24)	R-10.43 (1.84)	0.096 (0.54)	0.322 (0.558)

Temperature Indices

	R5	R15	R25	
T_{i1}	0.42	0.49	0.55	Min T on exterior face of concrete blocks, at top of slab, at air filled blocks
T_{i2}	0.78	0.82	0.83	Min T on interior surfaces, at floor/gypsum intersection, at studs

Detail 7.2.17

Exterior Insulated Concrete Block Wall Assembly with Masonry Ties Supporting Brick Veneer – Angle Supported Slab & Intermediate Floor Intersection

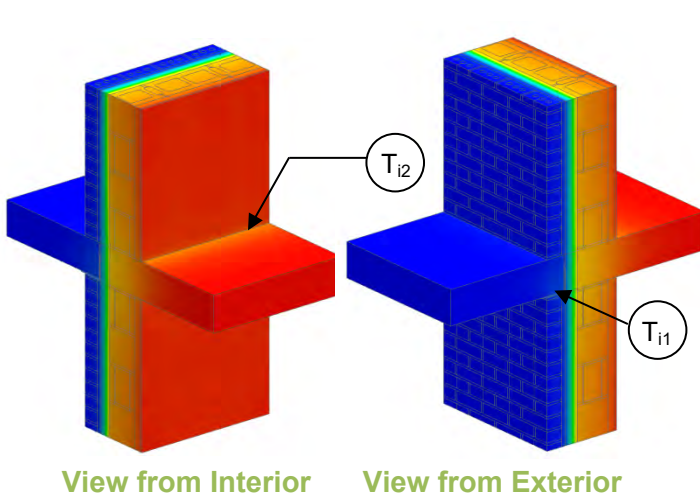

Thermal Performance Indicators

Assembly 1D (Nominal) R-Value	R_{1D}	R- 5.6 (0.98 RSI) + exterior insulation
Transmittance / Resistance without Anomaly	U_o, R_o	“clear wall” U- and R-value without balcony slab
Transmittance / Resistance	U, R	U- and R-values for overall assembly
Surface Temperature Index ¹	T_i	0 = exterior temperature 1 = interior temperature
Linear Transmittance	ψ	Incremental increase in transmittance per linear length of slab

¹Assumptions and limitations for surface temperatures identified in ASHRAE 1365-RP

Nominal (1D) vs. Assembly Performance Indicators

Exterior Insulation 1D R-Value (RSI)	R_{1D} ft ² ·hr·°F / Btu (m ² K / W)	R_o ft ² ·hr·°F / Btu (m ² K / W)	U_o Btu/ft ² ·hr ·°F (W/m ² K)	R ft ² ·hr·°F / Btu (m ² K / W)	U Btu/ft ² ·hr ·°F (W/m ² K)	ψ Btu/ft hr °F (W/m K)
R-5 (0.88)	R-10.6 (1.86)	R-10.4 (1.83)	0.096 (0.55)	R-8.4 (1.47)	0.120 (0.68)	0.140 (0.243)
R-15 (2.64)	R-20.6 (3.62)	R-17.8 (3.13)	0.056 (0.32)	R-13.0 (2.28)	0.077 (0.44)	0.126 (0.218)
R-25 (4.40)	R-30.6 (5.38)	R-23.7 (4.17)	0.042 (0.24)	R-16.2 (2.84)	0.062 (0.35)	0.118 (0.205)

Temperature Indices

	R5	R15	R25	
T_{i1}	0.55	0.65	0.70	Min T on exterior face of concrete blocks, at bottom of slab, at slab angle supports
T_{i2}	0.85	0.89	0.91	Min T on interior surfaces, at floor/gypsum intersection, at studs

Detail 7.2.18

Exterior Insulated Concrete Block Wall Assembly with Masonry Ties Supporting Brick Veneer – Intermediate Floor Intersection at Balcony

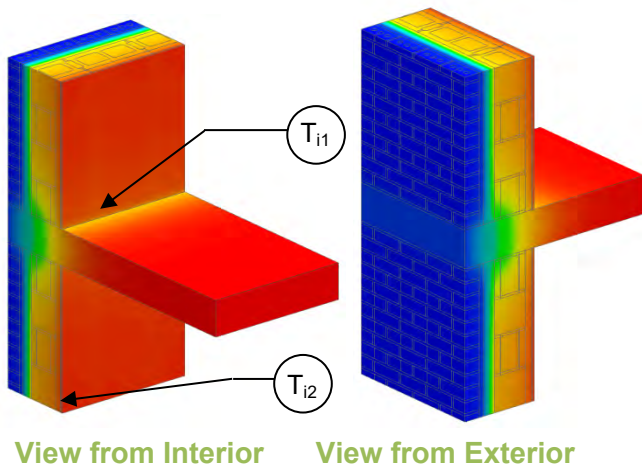

Thermal Performance Indicators

1.00	<table border="1"> <tr> <td>Assembly 1D (Nominal) R-Value</td> <td>R_{1D}</td> <td>R- 5.6 (0.98 RSI) + exterior insulation</td> </tr> <tr> <td>Transmittance / Resistance without Anomaly</td> <td>U_o, R_o</td> <td>“clear wall” U- and R-value without slab</td> </tr> <tr> <td>Transmittance / Resistance</td> <td>U, R</td> <td>U- and R-values for overall assembly</td> </tr> <tr> <td>Surface Temperature Index¹</td> <td>T_i</td> <td>0 = exterior temperature 1 = interior temperature</td> </tr> <tr> <td>Linear Transmittance</td> <td>ψ</td> <td>Incremental increase in transmittance per linear length of slab</td> </tr> </table>	Assembly 1D (Nominal) R-Value	R_{1D}	R- 5.6 (0.98 RSI) + exterior insulation	Transmittance / Resistance without Anomaly	U_o, R_o	“clear wall” U- and R-value without slab	Transmittance / Resistance	U, R	U- and R-values for overall assembly	Surface Temperature Index ¹	T_i	0 = exterior temperature 1 = interior temperature	Linear Transmittance	ψ	Incremental increase in transmittance per linear length of slab
Assembly 1D (Nominal) R-Value		R_{1D}	R- 5.6 (0.98 RSI) + exterior insulation													
Transmittance / Resistance without Anomaly		U_o, R_o	“clear wall” U- and R-value without slab													
Transmittance / Resistance		U, R	U- and R-values for overall assembly													
Surface Temperature Index ¹		T_i	0 = exterior temperature 1 = interior temperature													
Linear Transmittance		ψ	Incremental increase in transmittance per linear length of slab													
0.90																
0.80																
0.70																
0.60																
0.50																
0.40																
0.30																
0.20																
0.10																
0.00																

¹Assumptions and limitations for surface temperatures identified in ASHRAE 1365-RP

Nominal (1D) vs. Assembly Performance Indicators

Exterior Insulation 1D R-Value (RSI)	R_{1D} ft ² ·hr·°F / Btu (m ² K / W)	R_o ft ² ·hr·°F / Btu (m ² K / W)	U_o Btu/ft ² ·hr ·°F (W/m ² K)	R ft ² ·hr·°F / Btu (m ² K / W)	U Btu/ft ² ·hr ·°F (W/m ² K)	ψ Btu/ft hr °F (W/m K)
R-5 (0.88)	R-10.6 (1.86)	R-10.4 (1.83)	0.096 (0.55)	R-6.5 (1.14)	0.154 (0.88)	0.348 (0.602)
R-10 (1.76)	R-15.6 (2.74)	R-14.2 (2.50)	0.070 (0.40)	R-7.6 (1.34)	0.131 (0.75)	0.367 (0.636)
R-15 (2.64)	R-20.6 (3.62)	R-17.8 (3.13)	0.056 (0.32)	R-8.5 (1.50)	0.117 (0.67)	0.368 (0.636)
R-20 (3.52)	R-25.6 (4.50)	R-20.8 (3.66)	0.048 (0.27)	R-9.2 (1.61)	0.109 (0.62)	0.367 (0.636)
R-25 (4.40)	R-30.6 (5.38)	R-23.7 (4.17)	0.042 (0.24)	R-9.9 (1.75)	0.101 (0.57)	0.351 (0.607)

Temperature Indices

	R5	R15	R25	
T_{i1}	0.39	0.48	0.53	Min T on exterior face of concrete blocks, at top of slab, at air filled blocks
T_{i2}	0.77	0.81	0.83	Min T on interior surfaces, at floor/gypsum intersection, at studs

Detail 7.2.19

Exterior Insulated Concrete Block Wall Assembly with Thermally Broken Shelf Angle & Brick Ties Supporting Brick Veneer – Slab Intersection

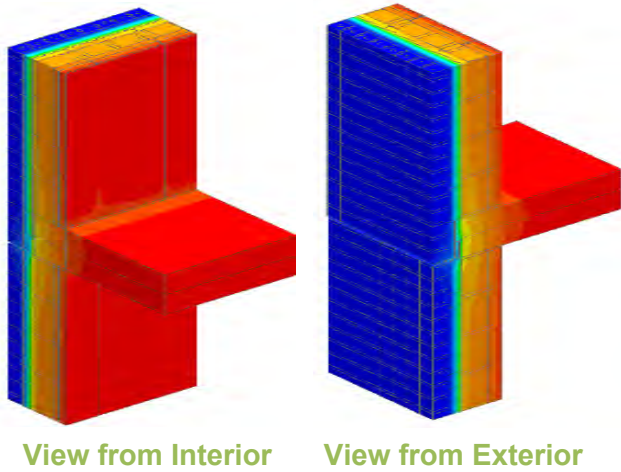

Thermal Performance Indicators

1.00	Assembly 1D (Nominal) R-Value	R_{1D}	R-5.6 (0.98 RSI) + exterior insulation
0.90	Transmittance / Resistance without Anomaly	U_o, R_o	“clear wall” U- and R-value without slab and shelf angle
0.80	Transmittance / Resistance	U, R	U- and R-values for overall assembly
0.70	Surface Temperature Index	T_i	0 = exterior temperature 1 = interior temperature
0.60	Linear Transmittance	ψ	Incremental increase in transmittance per linear length of slab with shelf angle
0.50			
0.40			
0.30			
0.20			
0.10			
0.00			

*Assumptions and limitations for surface temperatures identified in ASHRAE 1365-RP

Scenario

Scenario	Flashing and Shelf Angle
A	Self-Adhered Membrane Flashing with Steel Shelf Angle and Bolts
B	Self-Adhered Membrane Flashing with Stainless Steel Shelf Angle and Bolts

Nominal (1D) vs. Assembly Performance Indicators

Scenario	Exterior Insulation 1D R-Value (RSI)	R_{1D} ft ² ·hr·°F / Btu (m ² K / W)	R_o ft ² ·hr·°F / Btu (m ² K / W)	U_o Btu/ft ² ·hr·°F (W/m ² K)	R ft ² ·hr·°F / Btu (m ² K / W)	U Btu/ft ² ·hr·°F (W/m ² K)	ψ Btu/ft hr °F (W/m K)
A	R-15 (2.64)	R-20.6 (3.62)	R-17.8 (3.13)	0.056 (0.32)	R-13.6 (2.39)	0.074 (0.42)	0.108 (0.186)
B	R-15 (2.64)	R-20.6 (3.62)	R-17.8 (3.13)	0.056 (0.32)	R-14.4 (2.53)	0.070 (0.39)	0.082 (0.141)

Detail 7.2.20

Interior Insulated Concrete Mass Wall with 1 5/8" x 1 5/8" Steel Studs (16" o.c.) Supporting Interior Finish – Isokorb Rutherford DF Thermally Broken Concrete Intermediate Floor Intersection

Thermal Performance Indicators

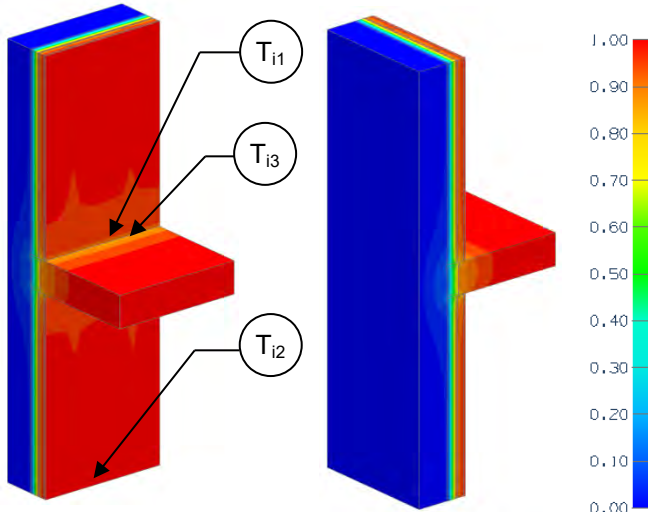

Assembly 1D (Nominal) R-Value	R_{1D}	R-2.9 (0.51 RSI) + interior insulation
Transmittance / Resistance without Anomaly	U_o, R_o	“clear wall” U- and R-value, without slab
Transmittance / Resistance	U, R	U and R-values for the assembly
Surface Temperature Index ¹	T_i	0 = exterior temperature 1 = interior temperature
Linear Transmittance	ψ	Incremental increase in transmittance per linear length of slab

¹Assumptions and limitations for surface temperatures identified in ASHRAE 1365-RP

View from Interior View from Exterior

Nominal (1D) vs. Assembly Performance Indicators

Interior Insulation 1D R-Value (RSI)	R_{1D} ft ² ·hr·°F / Btu (m ² K / W)	R_o ft ² ·hr·°F / Btu (m ² K / W)	U_o Btu/ft ² ·hr·°F (W/m ² K)	R ft ² ·hr·°F / Btu (m ² K / W)	U Btu/ft ² ·hr·°F (W/m ² K)	ψ Btu/ft hr °F (W/m K)
R-12.5 (1.76)	R-15.4 (2.71)	R-15.4 (2.70)	0.065 (0.37)	R-10.8 (1.90)	0.093 (0.53)	0.239 (0.414)

Temperature Indices

T_{i1}	0.85	Min T on insulation away from slab, between studs
T_{i2}	0.89	Max T on insulation away from slab, at studs
T_{i3}	0.75	Min T on slab exposed to interior air, at insulation between studs

Detail 7.2.21

Highly Insulated Precast Concrete Sandwich Panel Wall Assembly – Intermediate Floor Intersection with Inner Wythe Supported by Concrete Floor

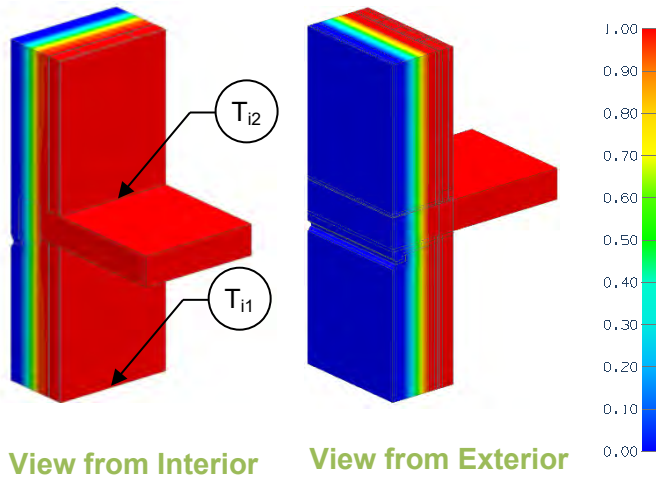

Thermal Performance Indicators

Assembly 1D (Nominal) R-Value	R_{1D}	R-2.76 (0.49 RSI) + insulation
Transmittance / Resistance without Anomaly	U_o, R_o	"clear field" U- and R-value
Transmittance / Resistance	U, R	U- and R-values for the overall assembly
Linear Transmittance	Ψ	Incremental increase in transmittance for intermediate slab

Nominal (1D) vs. Assembly Performance Indicators

Base Assembly – Wall

Wall Insulation R-Value/in	Wall Insulation 1D R-Value (RSI)	R_{1D} ft ² ·hr·°F / Btu (m ² K / W)	R_o ft ² ·hr·°F / Btu (m ² K / W)	U_o Btu/ft ² ·hr·°F (W/m ² K)
5	R-40 (7.04)	R-42.8 (7.53)	R-42.3 (7.45)	0.024 (0.134)
6	R-48 (8.45)	R-50.8 (8.94)	R-50.3 (8.86)	0.020 (0.113)
7	R-56 (9.86)	R-58.8 (10.35)	R-58.3 (10.27)	0.017 (0.097)

Slab Linear Transmittance

Wall Insulation R-Value/in	Wall Insulation 1D R-Value (RSI)	R ft ² ·hr·°F / Btu (m ² K / W)	U Btu/ft ² ·hr·°F (W/m ² K)	Ψ Btu/ft·hr·°F (W/mK)
5	R-42.8 (7.53)	R-41.4 (7.30)	0.024 (0.137)	0.0036 (0.0061)
6	R-50.8 (8.94)	R-47.9 (8.44)	0.021 (0.118)	0.0071 (0.0123)
6*	R-50.8 (8.94)	R-48.3 (8.52)	0.021 (0.117)	0.0057 (0.0099)
7	R-58.8 (10.35)	R-54.0 (9.52)	0.019 (0.105)	0.0098 (0.0169)

*With additional R-4 aerogel insulation at slab edge detail

Temperature Indices

	R42.8	R50.8	R50.8*	R58.8	
T_{i1}	0.95	0.96	0.96	0.97	Min T on interior precast sandwich panel away from slab, between studs
T_{i2}	0.96	0.97	0.97	0.97	Min T on slab exposed to interior air, at interior precast sandwich panel, between studs

*With additional R-4 aerogel insulation at slab edge detail

Detail 7.2.22

Owens Corning Exterior Insulated Concrete Block Wall Assembly with Shelf Angle and Heckmann Pos-I-Tie Veneer Anchoring System Supporting Brick Veneer – Intermediate Floor Intersection

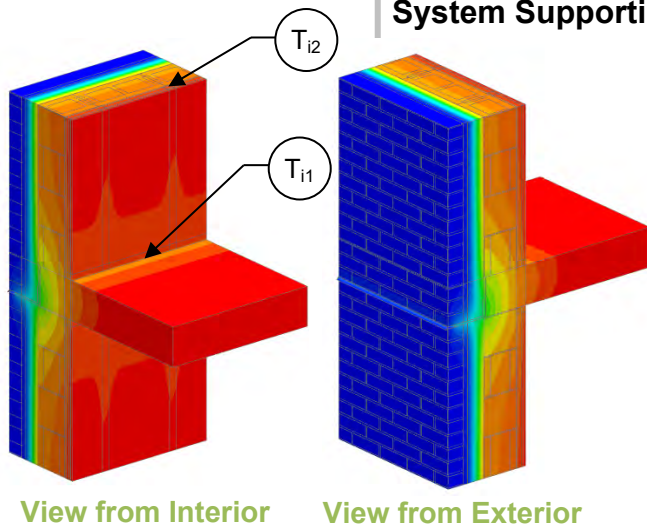

Thermal Performance Indicators

Assembly 1D (Nominal) R-Value	R_{1D}	R-5.6 (0.99 RSI) + exterior insulation
Transmittance / Resistance without Anomaly	U_o, R_o	“clear wall” U- and R-value without slab and shelf angle
Transmittance / Resistance	U, R	U- and R-values for overall assembly
Surface Temperature Index ¹	T_i	0 = exterior temperature 1 = interior temperature
Linear Transmittance	ψ	Incremental increase in transmittance per linear length of shelf angle and slab

¹Assumptions and limitations for surface temperatures identified in ASHRAE 1365-RP

Nominal (1D) vs. Assembly Performance Indicators

Exterior Insulation 1D R-Value (RSI)	R_{1D} ft ² ·hr·°F / Btu (m ² K / W)	R_o ft ² ·hr·°F / Btu (m ² K / W)	U_o Btu/ft ² ·hr·°F (W/m ² K)	R ft ² ·hr·°F / Btu (m ² K / W)	U Btu/ft ² ·hr·°F (W/m ² K)	ψ Btu/ft hr °F (W/m K)
R-10.0 (1.76)	R-15.6 (2.75)	R-13.4 (2.36)	0.075 (0.42)	R-8.3 (1.46)	0.121 (0.69)	0.277 (0.480)
R-20.0 (3.52)	R-25.6 (4.51)	R-20.0 (3.52)	0.050 (0.28)	R-10.1 (1.78)	0.099 (0.56)	0.292 (0.506)

Temperature Indices

	R10	R20	
T_{i1}	0.77	0.80	Min T on slab exposed to interior air, between studs
T_{i2}	0.85	0.86	Max T on concrete block away from slab, at studs

Detail 7.2.23

Owens Corning Exterior Insulated Concrete Block Wall Assembly with Stainless Steel Stand-off Shelf Angle and Heckmann Pos-I-Tie Vener Anchoring System Supporting Brick Veneer – Intermediate Floor Intersection

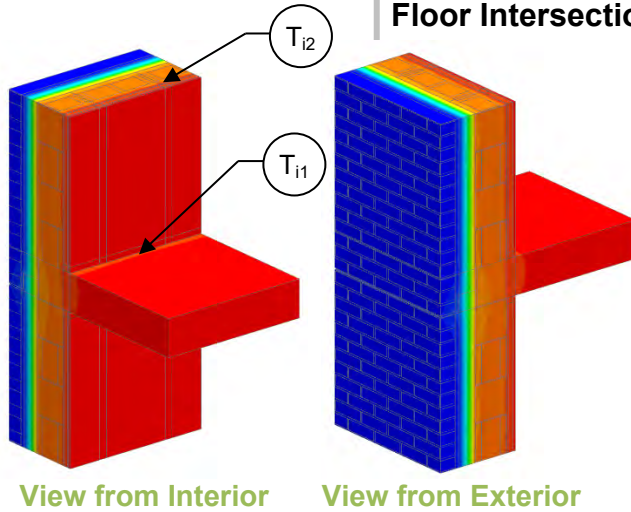

Thermal Performance Indicators

1.00	<table border="1"> <tr> <td>Assembly 1D (Nominal) R-Value</td> <td>R_{1D}</td> <td>R-5.6 (0.99 RSI) + exterior insulation</td> </tr> <tr> <td>Transmittance / Resistance without Anomaly</td> <td>U_o, R_o</td> <td>“clear wall” U- and R-value without slab and shelf angle</td> </tr> <tr> <td>Transmittance / Resistance</td> <td>U, R</td> <td>U- and R-values for overall assembly</td> </tr> <tr> <td>Surface Temperature Index¹</td> <td>T_i</td> <td>0 = exterior temperature 1 = interior temperature</td> </tr> <tr> <td>Linear Transmittance</td> <td>ψ</td> <td>Incremental increase in transmittance per linear length of shelf angle and slab</td> </tr> </table>	Assembly 1D (Nominal) R-Value	R_{1D}	R-5.6 (0.99 RSI) + exterior insulation	Transmittance / Resistance without Anomaly	U_o, R_o	“clear wall” U- and R-value without slab and shelf angle	Transmittance / Resistance	U, R	U- and R-values for overall assembly	Surface Temperature Index ¹	T_i	0 = exterior temperature 1 = interior temperature	Linear Transmittance	ψ	Incremental increase in transmittance per linear length of shelf angle and slab
Assembly 1D (Nominal) R-Value		R_{1D}	R-5.6 (0.99 RSI) + exterior insulation													
Transmittance / Resistance without Anomaly		U_o, R_o	“clear wall” U- and R-value without slab and shelf angle													
Transmittance / Resistance		U, R	U- and R-values for overall assembly													
Surface Temperature Index ¹		T_i	0 = exterior temperature 1 = interior temperature													
Linear Transmittance		ψ	Incremental increase in transmittance per linear length of shelf angle and slab													
0.90																
0.80																
0.70																
0.60																
0.50																
0.40																
0.30																
0.20																
0.10																
0.00																

¹Assumptions and limitations for surface temperatures identified in ASHRAE 1365-RP

Nominal (1D) vs. Assembly Performance Indicators

Exterior Insulation 1D R-Value (RSI)	R_{1D} ft ² ·hr·°F / Btu (m ² K / W)	R_o ft ² ·hr·°F / Btu (m ² K / W)	U_o Btu/ft ² ·hr·°F (W/m ² K)	R ft ² ·hr·°F / Btu (m ² K / W)	U Btu/ft ² ·hr·°F (W/m ² K)	ψ Btu/ft hr °F (W/m K)
R-10.0 (1.76)	R-15.6 (2.75)	R-13.4 (2.36)	0.075 (0.42)	R-11.7 (2.06)	0.085 (0.49)	0.064 (0.112)
R-20.0 (3.52)	R-25.6 (4.51)	R-20.0 (3.52)	0.050 (0.28)	R-16.9 (2.98)	0.059 (0.34)	0.054 (0.093)

Temperature Indices

	R10	R20	
T_{i1}	0.85	0.90	Min T on slab exposed to interior air, between studs
T_{i2}	0.88	0.92	Max T on concrete block away from slab, at studs

Detail 7.2.24

Exterior Insulated Concrete Mass Wall with 1 5/8" x 1 5/8" Steel Stud (16" o.c.) and Thermally Isolated Vertical Brackets and Rail System (24" o.c.) Supporting Metal Cladding – Intermediate Floor Intersection

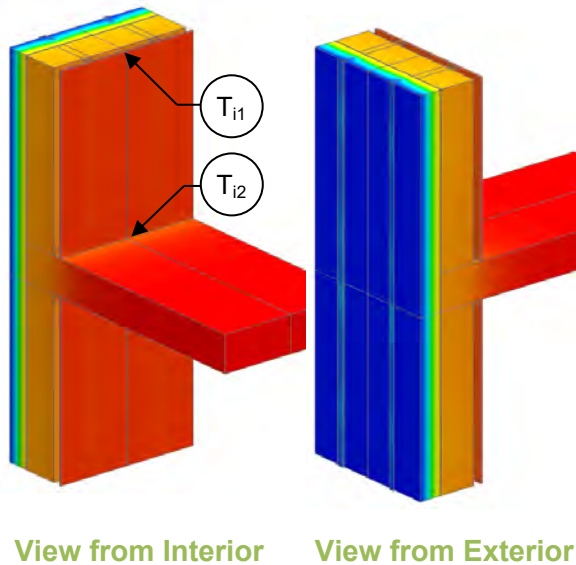

Thermal Performance Indicators

Assembly 1D (Nominal) R-Value	R_{1D}	R-3.4 (0.59 RSI) + exterior insulation
Transmittance / Resistance without Anomaly	U_o, R_o	“clear wall” U- and R-value without slab
Transmittance / Resistance	U, R	U and R-values for overall assembly
Surface Temperature Index ¹	T_i	0 = exterior temperature 1 = interior temperature
Linear Transmittance	ψ	Incremental increase in transmittance per linear length of slab

¹Assumptions and limitations for surface temperatures identified in ASHRAE 1365-RP

Nominal (1D) vs. Assembly Performance Indicators

Exterior Insulation 1D R-Value (RSI)	R_{1D} ft ² ·hr·°F / Btu (m ² K / W)	R_o ft ² ·hr·°F / Btu (m ² K / W)	U_o Btu/ft ² ·hr·°F (W/m ² K)	R ft ² ·hr·°F / Btu (m ² K / W)	U Btu/ft ² ·hr·°F (W/m ² K)	ψ Btu/ft ² ·hr·°F (W/m ² K)
R-10 (1.76)	R-13.4 (2.35)	R-10.9 (1.92)	0.092 (0.52)	R-10.4 (1.84)	0.096 (0.55)	0.030 (0.052)
R-15 (2.64)	R-18.4 (3.23)	R-13.3 (2.34)	0.075 (0.43)	R-12.6 (2.22)	0.079 (0.45)	0.030 (0.051)
R-20 (3.52)	R-23.4 (4.11)	R-15.9 (2.80)	0.063 (0.36)	R-15.0 (2.65)	0.066 (0.38)	0.026 (0.045)
R-25 (4.40)	R-28.4 (4.99)	R-18.3 (3.22)	0.055 (0.31)	R-17.3 (3.05)	0.058 (0.33)	0.022 (0.037)

Temperature Indices

	R10	R15	R20	R25	
T_{i1}	0.82	0.85	0.88	0.90	Min T on concrete away from slab, between studs
T_{i2}	0.87	0.89	0.91	0.92	Min T on slab exposed to interior air, at concrete, at studs

Detail 7.2.25

Insulated Precast Concrete Sandwich Panel Wall Assembly – Intermediate Floor Intersection with Inner Wythe Supported by Concrete Floor

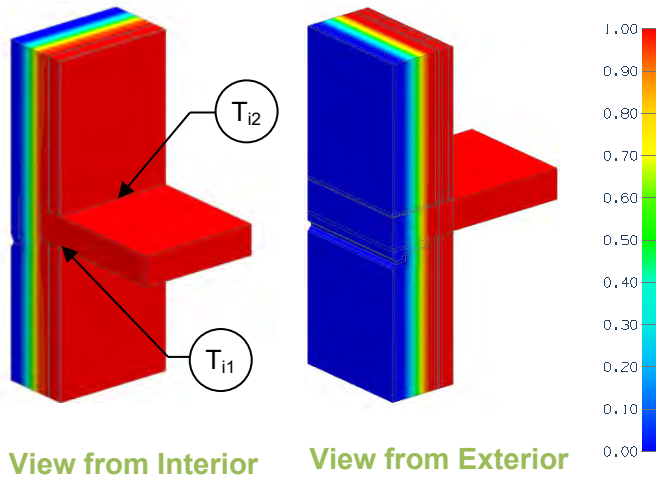

Thermal Performance Indicators

Assembly 1D (Nominal) R-Value	R_{1D}	R-3.9 (0.69 RSI) + insulation
Transmittance / Resistance without Anomaly	U_o, R_o	"clear field" U- and R-value
Transmittance / Resistance	U, R	U- and R-values for the overall assembly
Linear Transmittance	Ψ	Incremental increase in transmittance for intermediate slab

Nominal (1D) vs. Assembly Performance Indicators

Base Assembly – Precast Clear Wall

Sandwich Panel Insulation 1D R-Value (RSI)	R_{1D} ft ² ·hr·°F / Btu (m ² K / W)	R_o ft ² ·hr·°F / Btu (m ² K / W)	U_o Btu/ft ² ·hr·°F (W/m ² K)
R-10 (1.76)	R-13.9 (2.45)	R-12.6 (2.22)	0.079 (0.45)
R-15 (2.64)	R-18.9 (3.33)	R-17.2 (3.03)	0.058 (0.33)
R-20 (3.52)	R-23.9 (4.21)	R-22.4 (3.94)	0.045 (0.25)

Slab Linear Transmittance – With Flashing

Wall Insulation 1D R-Value (RSI)	R ft ² ·hr·°F / Btu (m ² K / W)	U Btu/ft ² ·hr·°F (W/m ² K)	Ψ Btu/ft·hr·°F (W/mK)
R-10.0 (1.76)	R-11.7 (2.07)	0.085 (0.48)	0.043 (0.074)
R-15.0 (2.64)	R-15.7 (2.76)	0.064 (0.36)	0.041 (0.071)
R-20.0 (3.52)	R-19.5 (3.44)	0.051 (0.29)	0.047 (0.082)

Slab Linear Transmittance – Without Flashing

Wall Insulation 1D R-Value (RSI)	R ft ² ·hr·°F / Btu (m ² K / W)	U Btu/ft ² ·hr·°F (W/m ² K)	Ψ Btu/ft·hr·°F (W/mK)
R-10.0 (1.76)	R-12.3 (2.17)	0.081 (0.46)	0.013 (0.023)
R-15.0 (2.64)	R-16.6 (2.93)	0.060 (0.34)	0.015 (0.025)
R-20.0 (3.52)	R-21.9 (3.86)	0.046 (0.26)	0.007 (0.011)

Temperature Indices

	With flashing			Without flashing			
	R10	R15	R20	R10	R15	R20	
T_{i1}	0.93	0.95	0.96	0.94	0.96	0.97	Min T on concrete ceiling slab at gypsum wall.
T_{i2}	0.93	0.95	0.95	0.94	0.96	0.97	Min T on concrete floor slab at gypsum wall.

Detail 7.3.1

Exterior Insulated Concrete Drained EIFS Wall Assembly – Window and Intermediate Floor Intersection

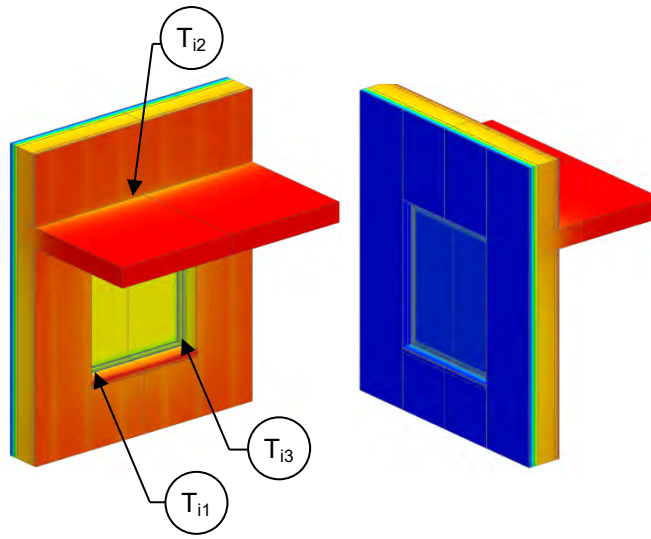

View from Interior

View from Exterior

Thermal Performance Indicators

Assembly 1D (Nominal) R-Value	R_{1D}	R-3.0 (0.53 RSI) + exterior insulation
Transmittance / Resistance without Anomaly	U_w, R_w, U_g	“clear wall” U- and R-value: w = wall without slab g = glazing
Transmittance / Resistance	U_s, R_s, U_t, R_t	U and R-values for s = wall + slab t = combined wall + slab + window
Surface Temperature Index ¹	T_i	0 = exterior temperature 1 = interior temperature
Linear Transmittance	ψ_s, ψ_g	Incremental increase in transmittance per linear length of: s = slab g = glazing transition

¹Assumptions and limitations for surface temperatures identified in ASHRAE 1365-RP

Nominal (1D) vs. Assembly Performance Indicators

Base Assembly – Concrete Clear Wall

Exterior Insulation 1D R-Value (RSI)	R_{1D} ft ² ·hr·°F / Btu (m ² K / W)	R_w ft ² ·hr·°F / Btu (m ² K / W)	U_w Btu/ft ² ·hr ·°F (W/m ² K)
R-15 (2.64)	R-18.0 (3.17)	R-17.6 (3.10)	0.057 (0.32)

Base Assembly - Glazing

$U_{\text{centre of glazing}}$ Btu/ft ² ·hr ·°F (W/m ² K)	U_g Btu/ft ² ·hr ·°F (W/m ² K)
0.321 (1.82)	0.400 (2.27)

Slab Linear Transmittance

Exterior Insulation 1D R-Value (RSI)	R_s ft ² ·hr·°F / Btu (m ² K / W)	U_s Btu/ft ² ·hr ·°F (W/m ² K)	ψ_s Btu/ft ² ·hr ·°F (W/m ² K)
R-15 (2.64)	R-17.1 (3.02)	0.058 (0.33)	0.013 (0.023)

Window Transition Linear Transmittance

R_t ft ² ·hr·°F / Btu (m ² K / W)	U_t Btu/ft ² ·hr ·°F (W/m ² K)	ψ_g^2 Btu/ft hr °F (W/m K)
R-5.6 (0.98)	0.179 (1.02)	0.177 (0.307)

Temperature Indices

T_{i1}	0.73	Min T on concrete interior surface, below window sill between studs
T_{i2}	0.89	Max T on concrete, at floor slab intersection away from window
T_{i3}	0.60	Min T on window frame, at corner of glass

²For the linear transmittance, use the window perimeter

Detail 7.3.2

Interior Insulated Concrete Mass Wall with 1 5/8" x 1 5/8" Steel Studs (16" o.c.) Supporting Interior Finish – Window & Intermediate Floor Intersection

Thermal Performance Indicators

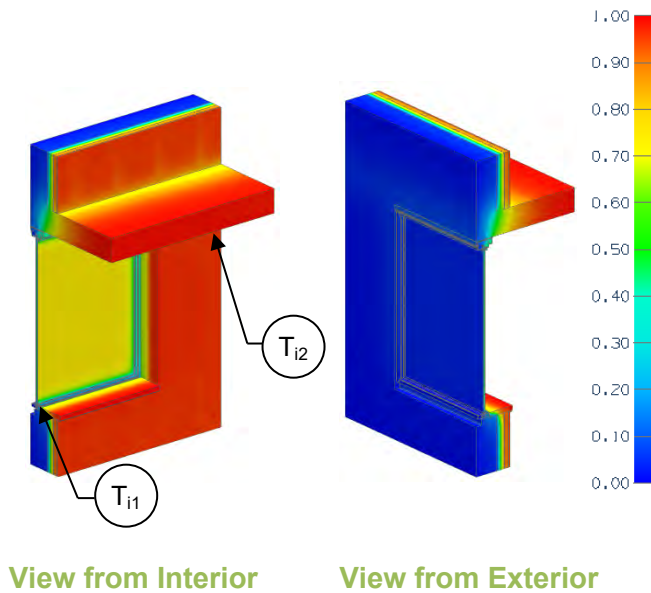

Assembly 1D (Nominal) R-Value	R_{1D}	R-2.9 (0.51 RSI) + interior insulation
Transmittance / Resistance without Anomaly	U_w , R_w , U_g	“clear wall” U- and R-value: w = concrete wall without slab g = glazing
Transmittance / Resistance	U_s , R_s , U_t , R_t	U and R-values for: s = wall + slab t = combined wall + slab + window
Surface Temperature Index ¹	T_i	0 = exterior temperature 1 = interior temperature
Linear Transmittance	ψ_s , ψ_g	Incremental increase in transmittance per linear length of: s = slab g = glazing transition

¹Assumptions and limitations for surface temperatures identified in ASHRAE 1365-RP

Nominal (1D) vs. Assembly Performance Indicators

Base Assembly – Concrete Clear Wall

Interior Insulation 1D R-Value (RSI)	R_{1D} ft ² ·hr·°F / Btu (m ² K / W)	R_w ft ² ·hr·°F / Btu (m ² K / W)	U_w Btu/ft ² ·hr ·°F (W/m ² K)
R-10 (1.76)	R-12.9 (2.27)	R-12.9 (2.26)	0.078 (0.44)
R-15 (2.64)	R-17.9 (3.15)	R-17.9 (3.14)	0.056 (0.32)

Slab Linear Transmittance

R_s ft ² ·hr·°F / Btu (m ² K / W)	U_s Btu/ft ² ·hr ·°F (W/m ² K)	ψ_s Btu/ft ² ·hr ·°F (W/m ² K)
R-7.3 (1.29)	0.137 (0.78)	0.514 (0.889)
R-8.4 (1.49)	0.119 (0.647)	0.545 (0.943)

Window Transition Linear Transmittance

Interior Insulation 1D R-Value (RSI)	Without Steel Sheet Connected to Studs			With Steel Sheet Connected to Studs		
	R_t ft ² ·hr·°F / Btu (m ² K / W)	U_t Btu/ft ² ·hr ·°F (W/m ² K)	ψ_g^2 Btu/ft ² ·hr ·°F (W/m K)	R_t ft ² ·hr·°F / Btu (m ² K / W)	U_t Btu/ft ² ·hr ·°F (W/m ² K)	ψ_g^2 Btu/ft ² ·hr ·°F (W/m K)
R-10 (1.76)	R-3.5 (0.62)	0.285 (1.62)	0.144 (0.248)	R-3.4 (0.6)	0.292 (1.66)	0.170 (0.294)
R-15 (2.64)	R-3.7 (0.65)	0.272 (1.54)	0.158 (0.273)	R-3.6 (0.63)	0.279 (1.58)	0.186 (0.322)

²For the linear transmittance, use the window perimeter

Temperature Indices

	Without Sheet		With Sheet		
	R10	R15	R10	R15	
T_{11}	0.24	0.24	0.29	0.28	Min T on window frame, at bottom middle of glazing
T_{12}	0.07	0.05	0.07	0.05	Min T on concrete, away from window slab and studs

Base Assembly - Glazing

$U_{\text{centre of glass}}$ Btu/ft ² ·hr ·°F (W/m ² K)	U_g Btu/ft ² ·hr ·°F (W/m ² K)
0.321 (1.82)	0.400 (2.27)



Detail 7.3.3

Interior Insulated Concrete Mass Wall with 1 5/8" x 1 5/8" Steel Studs (16" o.c.) Supporting Interior Finish – Window & Projected Slab Intersection

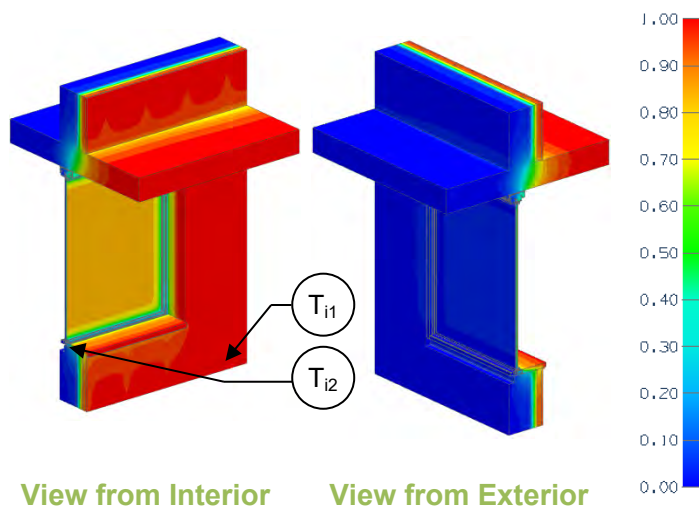

View from Interior

View from Exterior

Scenario

Scenario	Sill Sheet Steel
A, B	None
C, D	Yes

Base Assembly – Glazing

$U_{\text{centre of glass}}$ Btu/ft ² · hr · °F (W/m ² K)	U_g Btu/ft ² · hr · °F (W/m ² K)
0.321 (1.82)	0.400 (2.27)

Thermal Performance Indicators

Assembly 1D (Nominal) R-Value	R_{1D}	R-2.9 (0.51 RSI) + interior insulation
Transmittance / Resistance without Anomaly	U_w, R_w, U_g	“clear wall” U- and R-value: w = concrete wall without slab g = glazing
Transmittance / Resistance	U_s, R_s, U_t, R_t	U and R-values for: s = wall + slab t = combined wall + slab + window
Surface Temperature Index ¹	T_i	0 = exterior temperature 1 = interior temperature
Linear Transmittance	$\Psi_h, \Psi_j, \Psi_l, \Psi_g, \Psi_s$	Incremental increase in transmittance per linear length of: h = head j = jamb l = sill g = overall glazing s = slab

¹Assumptions and limitations for surface temperatures identified in ASHRAE 1365-RP

Nominal (1D) vs. Assembly Performance Indicators

Window Transition Transmittance

Scenario	Interior Insulation 1D R-Value (RSI)	R_t ft ² ·hr·°F / Btu (m ² K / W)	U_t Btu/ft ² · hr · °F (W/m ² K)	Ψ_h Btu/ft · hr · °F (W/m K)	Ψ_l Btu/ft · hr · °F (W/m K)	Ψ_j Btu/ft · hr · °F (W/m K)	Ψ_g Btu/ft · hr · °F (W/m K)
A	R-10 (1.76)	R-3.5 (0.62)	0.283 (1.61)	0.091 (0.158)	0.084 (0.145)	0.217 (0.376)	0.143 (0.248)
B	R-15 (2.64)	R-3.7 (0.65)	0.270 (1.53)	0.129 (0.224)	0.094 (0.163)	0.224 (0.388)	0.160 (0.277)
C	R-10 (1.76)	R-3.5 (0.61)	0.290 (1.65)	0.091 (0.158)	0.176 (0.305)	0.217 (0.376)	0.170 (0.293)
D	R-15 (2.64)	R-3.6 (0.64)	0.277 (1.57)	0.129 (0.224)	0.192 (0.333)	0.224 (0.388)	0.188 (0.325)

Base Assembly – Concrete Clear Wall

Interior Insulation 1D R-Value (RSI)	R_{1D} ft ² ·hr·°F / Btu (m ² K / W)	R_w ft ² ·hr·°F / Btu (m ² K / W)	U_w Btu/ft ² · hr · °F (W/m ² K)
R-10 (1.76)	R-12.9 (2.28)	R-12.3 (2.16)	0.077 (0.44)
R-15 (2.64)	R-17.9 (3.16)	R-17.3 (3.05)	0.056 (0.32)

Slab Linear Transmittance

R_s ft ² ·hr·°F / Btu (m ² K / W)	U_s Btu/ft ² · hr · °F (W/m ² K)	Ψ_s Btu/ft ² · hr · °F (W/m ² K)
R-7.4 (1.3)	0.135 (0.77)	0.499 (0.864)
R-9.1 (1.6)	0.110 (0.63)	0.471 (0.815)

Temperature Indices

	A	B	C	D	
T_{i1}	0.07	0.05	0.07	0.05	Min T on concrete, away from window slab and studs
T_{i2}	0.29	0.28	0.23	0.23	Min T on window frame, at bottom middle of glazing



Detail 7.3.4

Precast Sandwich Panel Wall Assembly with Concrete at Panel Perimeter and Steel Connectors (24" o.c.) - Window Intersection

Thermal Performance Indicators

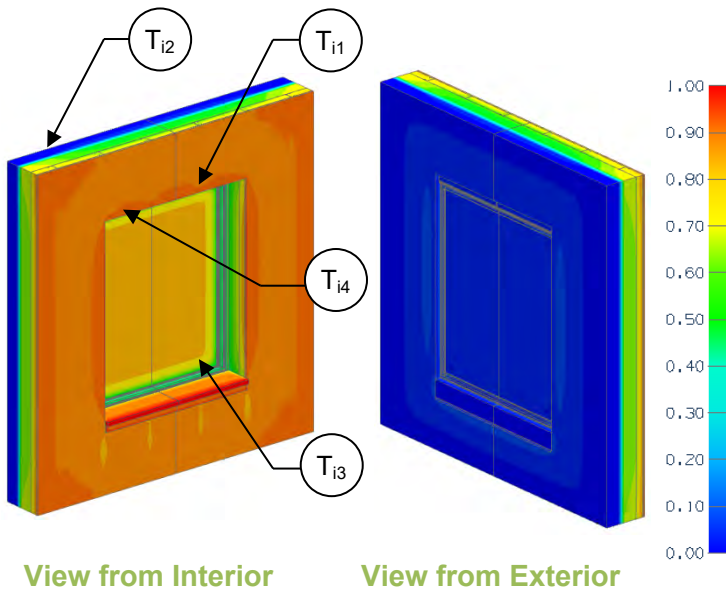

Assembly 1D (Nominal) R-Value	R_{1D}	R-3.9 (0.69 RSI) + sandwich panel insulation
Transmittance / Resistance without Anomaly	U_w , R_w , U_g	“clear wall” U- and R-value: w = sandwich panel g = glazing
Transmittance / Resistance	U_j , R_j , U_t , R_t	U and R-values for: j = sandwich panel with concrete perimeter t = sandwich panel with concrete perimeter + glazing
Surface Temperature Index ¹	T_i	0 = exterior temperature 1 = interior temperature
Linear Transmittance	ψ_j , ψ_t	Incremental increase in transmittance per linear length of: j = concrete perimeter t = glazing transition

¹Assumptions and limitations for surface temperatures identified in ASHRAE 1365-RP

Nominal (1D) vs. Assembly Performance Indicators

Base Assembly – Precast Clear Wall

Sandwich Panel Insulation 1D R-Value (RSI)	R_{1D} ft ² ·hr·°F / Btu (m ² K / W)	R_w ft ² ·hr·°F / Btu (m ² K / W)	U_w Btu/ft ² ·hr ·°F (W/m ² K)
R-10 (1.76)	R-13.9 (2.45)	R-12.6 (2.22)	0.079 (0.45)

Base Assembly - Glazing

$U_{\text{centre of glass}}$ Btu/ft ² ·hr ·°F (W/m ² K)	U_g Btu/ft ² ·hr ·°F (W/m ² K)
0.321 (1.82)	0.400 (2.27)

Window Transition Linear Transmittance

Sandwich Panel Insulation 1D R-Value (RSI)	R_t ft ² ·hr·°F / Btu (m ² K / W)	U_t Btu/ft ² ·hr ·°F (W/m ² K)	ψ_t^2 Btu/ft ·hr ·°F (W/m K)
R-10 (1.76)	R-1.9 (0.33)	0.536 (3.04)	0.789 (1.366)

²For the linear transmittance, use the window perimeter

Temperature Indices

T_{i1}	0.45	Min T on sandwich panel, at concrete edge next to window opening
T_{i2}	0.69	Max T on sandwich panel, at centre of panel away from concrete edges
T_{i3}	0.43	Min T on glazing, at corner of window frame
T_{i4}	0.40	Min T on window frame, at window head

Detail 7.3.5

Precast Sandwich Panel Wall Assembly with Steel Connectors at 24" (o.c.), and 3 5/8" Steel Stud (16" o.c.) – Window Intersection

Thermal Performance Indicators

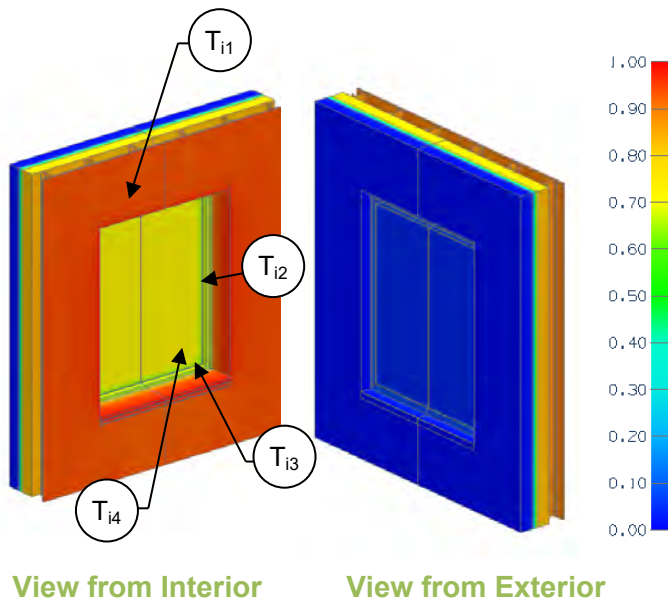

Assembly 1D (Nominal) R-Value	R_{1D}	R-3.9 (0.69 RSI) + sandwich panel insulation
Transmittance / Resistance without Anomaly	U_w , R_w , U_g	"clear wall" U- and R-value: w = sandwich panel g = glazing
Transmittance / Resistance	U_t , R_t	U and R-values for combined wall and window
Surface Temperature Index ¹	T_i	0 = exterior temperature 1 = interior temperature
Linear Transmittance	Ψ_h , Ψ_j , Ψ_l , Ψ_g	Incremental increase in transmittance per linear length of: h = head j = jamb l = sill g = overall glazing

¹Assumptions and limitations for surface temperatures identified in ASHRAE 1365-RP

Nominal (1D) vs. Assembly Performance Indicators

Base Assembly – Precast Clear Wall

Sandwich Panel Insulation 1D R-Value (RSI)	R_{1D} ft ² ·hr·°F / Btu (m ² K / W)	R_w ft ² ·hr·°F / Btu (m ² K / W)	U_w Btu/ft ² ·hr·°F (W/m ² K)
R-10 (1.76)	R-13.9 (2.45)	R-12.6 (2.22)	0.079 (0.45)
R-15 (2.64)	R-18.9 (3.33)	R-17.2 (3.03)	0.058 (0.33)
R-20 (3.52)	R-23.9 (4.21)	R-22.4 (3.94)	0.045 (0.25)

Base Assembly - Glazing

$U_{\text{centre of glass}}$ Btu/ft ² ·hr·°F (W/m ² K)	U_g Btu/ft ² ·hr·°F (W/m ² K)
0.321 (1.82)	0.400 (2.27)

Window Transition Transmittance

Sandwich Panel Insulation 1D R-Value (RSI)	R_t ft ² ·hr·°F / Btu (m ² K / W)	U_t Btu/ft ² ·hr·°F (W/m ² K)	Ψ_h Btu/ft·hr·°F (W/m K)	Ψ_l Btu/ft·hr·°F (W/m K)	Ψ_j Btu/ft·hr·°F (W/m K)	Ψ_g Btu/ft·hr·°F (W/m K)
R-10 (1.76)	R-5.1 (0.91)	0.195 (1.11)	0.051 (0.089)	0.058 (0.101)	0.021 (0.036)	0.040 (0.069)
R-15 (2.64)	R-5.6 (0.99)	0.179 (1.01)	0.048 (0.082)	0.060 (0.103)	0.015 (0.025)	0.034 (0.059)
R-20 (3.52)	R-6.0 (1.06)	0.167 (0.95)	0.033 (0.057)	0.062 (0.107)	0.013 (0.022)	0.025 (0.044)

Window Transition Transmittance – No Flashing

Sandwich Panel Insulation 1D R-Value (RSI)	R_t ft ² ·hr·°F / Btu (m ² K / W)	U_t Btu/ft ² ·hr·°F (W/m ² K)	Ψ_h Btu/ft·hr·°F (W/m K)	Ψ_l Btu/ft·hr·°F (W/m K)	Ψ_j Btu/ft·hr·°F (W/m K)	Ψ_g Btu/ft·hr·°F (W/m K)
R-10 (1.76)	5.2 (0.92)	0.192 (1.09)	0.051 (0.089)	0.024 (0.042)	0.021 (0.036)	0.031 (0.054)
R-15 (2.64)	5.7 (1.00)	0.176 (1.00)	0.048 (0.082)	0.025 (0.042)	0.015 (0.025)	0.026 (0.044)
R-20 (3.52)	6.1 (1.07)	0.164 (0.93)	0.033 (0.057)	0.024 (0.043)	0.013 (0.022)	0.017 (0.029)

Temperature Indices

	R10	R15	R20	
T_{11}	0.83	0.87	0.92	Min T on concrete wall, centered above window head
T_{12}	0.85	0.89	0.89	Max T on concrete wall, at steel stud and window frame
T_{13}	0.55 (0.57)	0.55 (0.57)	0.54 (0.56)	Min T on window frame, at bottom corner (no flashing)
T_{14}	0.62 (0.66)	0.62 (0.66)	0.62 (0.66)	Min T on window glass, in lower corner (no flashing)

Detail 7.3.6

Exterior Insulated Concrete Drained EIFS Wall Assembly – Window with Aerogel and Intermediate Floor Intersection

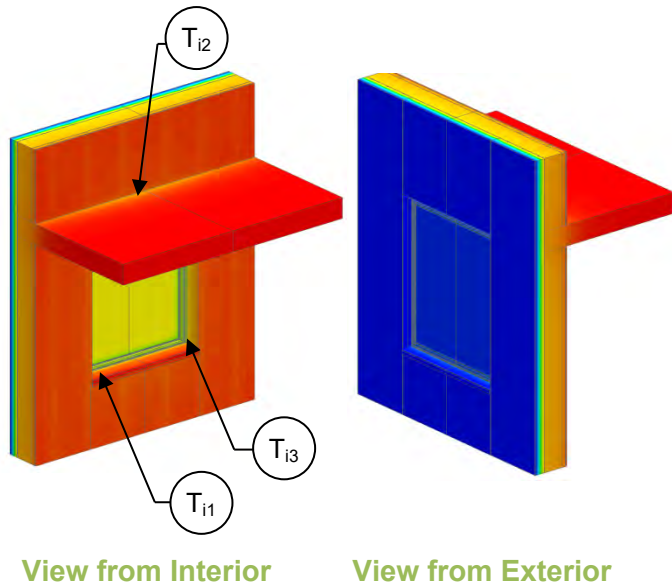

Thermal Performance Indicators

Assembly 1D (Nominal) R-Value	R_{1D}	R-3.0 (0.53 RSI) + exterior insulation
Transmittance / Resistance without Anomaly	U_w, R_w, U_g	“clear wall” U- and R-value: w = wall without slab g = glazing
Transmittance / Resistance	U_s, R_s, U_t, R_t	U and R-values for: s = wall + slab t = combined wall + slab + window
Surface Temperature Index ¹	T_i	0 = exterior temperature 1 = interior temperature
Linear Transmittance	Ψ_s, Ψ_g	Incremental increase in transmittance per linear length of s = slab g = glazing transition

¹Assumptions and limitations for surface temperatures identified in ASHRAE 1365-RP

Nominal (1D) vs. Assembly Performance Indicators

Base Assembly – Concrete Clear Wall

Exterior Insulation 1D R-Value (RSI)	R_{1D} ft ² ·hr·°F / Btu (m ² K / W)	R_w ft ² ·hr·°F / Btu (m ² K / W)	U_w Btu/ft ² ·hr ·°F (W/m ² K)
R-15 (2.64)	R-18.0 (3.17)	R-17.6 (3.10)	0.057 (0.32)

Base Assembly - Glazing

$U_{\text{centre of glazing}}$ Btu/ft ² ·hr ·°F (W/m ² K)	U_g Btu/ft ² ·hr ·°F (W/m ² K)
0.321 (1.82)	0.400 (2.27)

Slab Linear Transmittance

Exterior Insulation 1D R-Value (RSI)	R_s ft ² ·hr·°F / Btu (m ² K / W)	U_s Btu/ft ² ·hr ·°F (W/m ² K)	Ψ_s Btu/ft ² ·hr ·°F (W/m ² K)
R-15 (2.64)	R-17.1 (3.02)	0.058 (0.33)	0.013 (0.023)

Window Transition Linear Transmittance

R_t ft ² ·hr·°F / Btu (m ² K / W)	U_t Btu/ft ² ·hr ·°F (W/m ² K)	Ψ_g^2 Btu/ft hr °F (W/m K)
R-6.1 (1.07)	0.164 (0.93)	0.106 (0.184)

Temperature Indices

T_{i1}	0.82	Min T on concrete interior surface, below window sill between studs
T_{i2}	0.91	Max T on concrete, at floor slab intersection away from window
T_{i3}	0.59	Min T on window frame, at corner of glass

²For the linear transmittance, use the window perimeter

Detail 7.3.7

Interior Insulated Concrete Block or Concrete Wall Assembly with Brick Cladding - Window Intersection

Detail referenced from work done by Passive House Academy

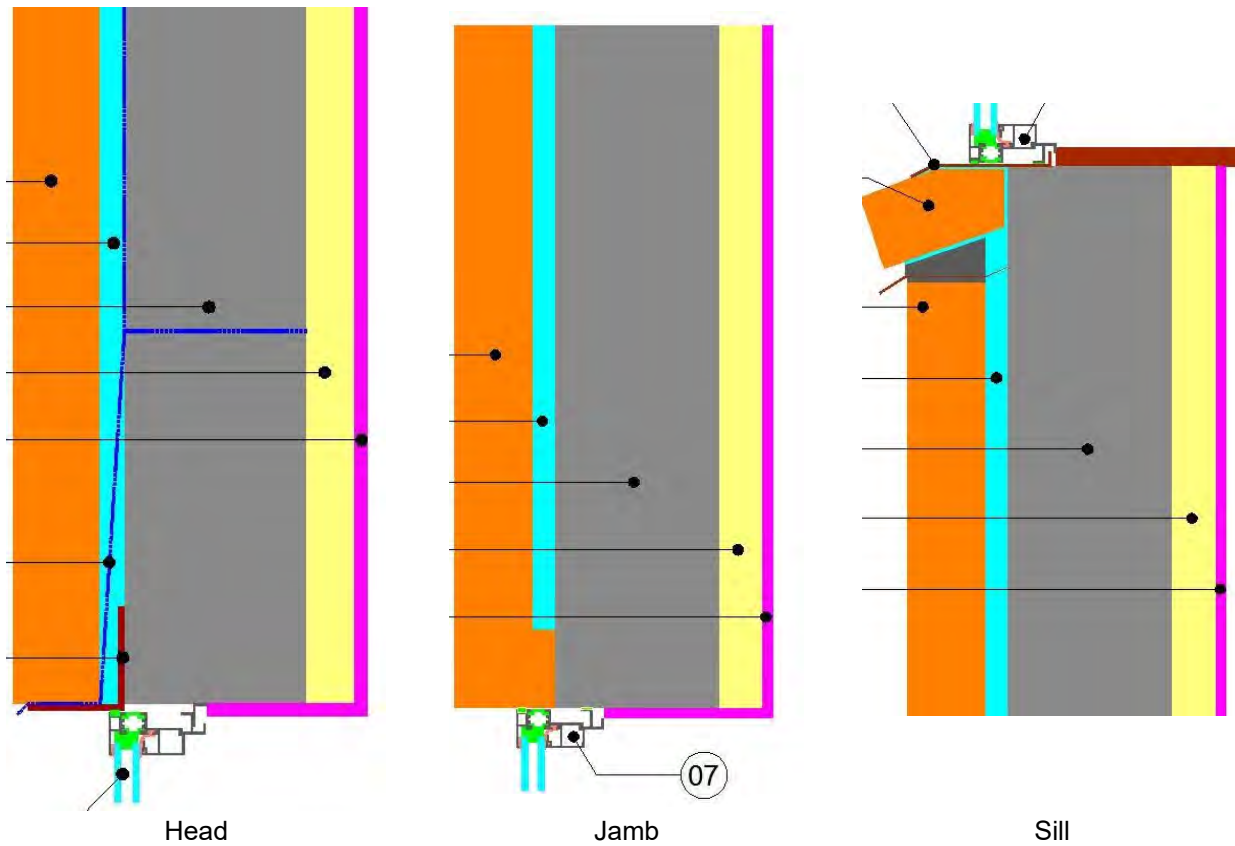

Thermal Performance

Condition	Clear Wall R-Value ft ² ·hr·°F / Btu (m ² K / W)	Clear Wall U-Value Btu / ft ² ·hr·°F (W/m ² K)	Linear Transmittance (Ψ) Btu/hr ft F (W/m K)
Wall Clear Field	R-16.0 (2.85)	0.063 (0.351)	-
Typical Jamb			0.308 (0.533)
Typical Head			0.315 (0.546)
Typical Sill			0.322 (0.558)
Typical Overall Window			0.313 (0.543)

Detail 7.3.8

Interior Insulated Concrete Block or Concrete Wall Assembly with Brick Cladding - Window Intersection Aligned with Insulation

Detail referenced from work done by Passive House Academy

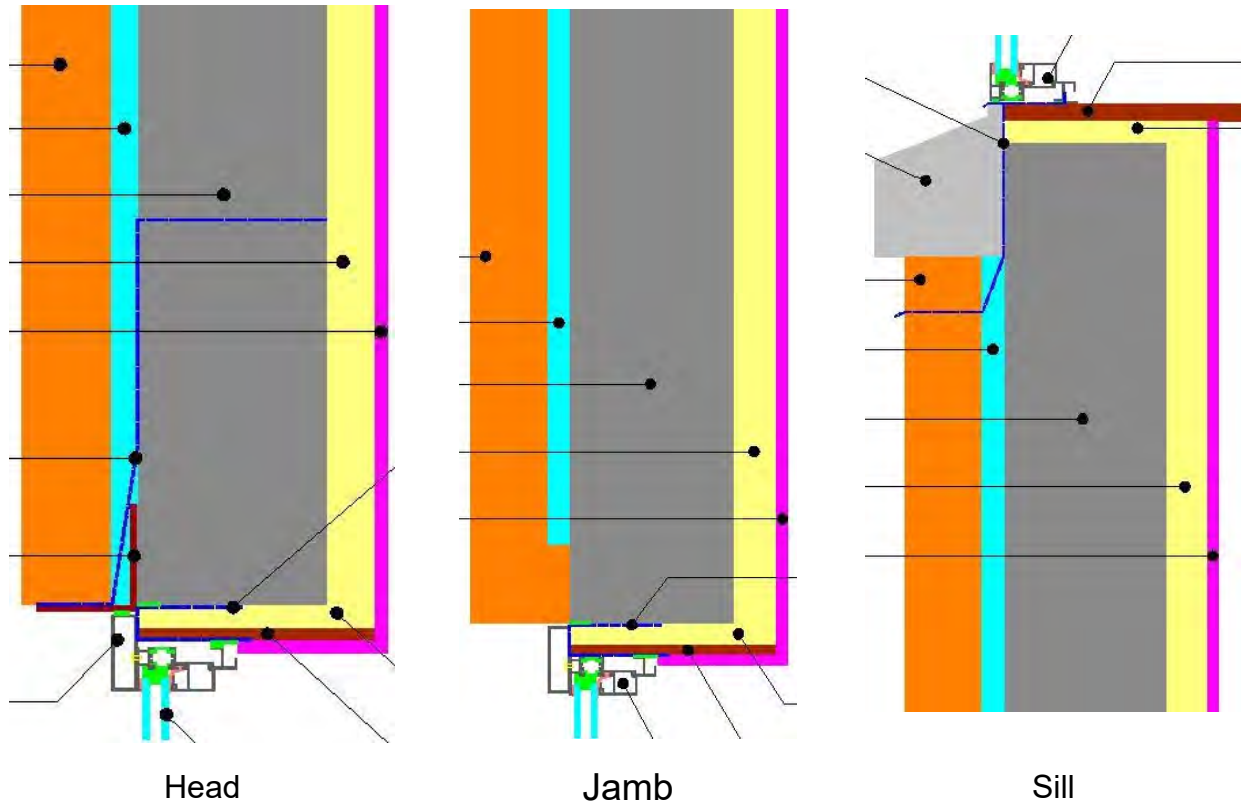

Thermal Performance

Condition	Clear Wall R-Value ft ² ·hr·°F / Btu (m ² K / W)	Clear Wall U-Value Btu / ft ² ·hr·°F (W/m ² K)	Linear Transmittance (Ψ) Btu/hr ft °F (W/m K)
Wall Clear Field	R-16.0 (2.85)	0.063 (0.351)	-
Aligned Jamb			0.079 (0.136)
Aligned Head			0.086 (0.149)
Aligned Sill			0.088 (0.152)
Aligned Overall Window			0.083 (0.143)

Detail 7.3.9

Interior Insulated Concrete Mass Wall with 1 5/8" x 1 5/8" Steel Studs (16" o.c.) Supporting Interior Finish – Window & Projected Slab Intersection with Plywood and Insulation Liner

Thermal Performance Indicators

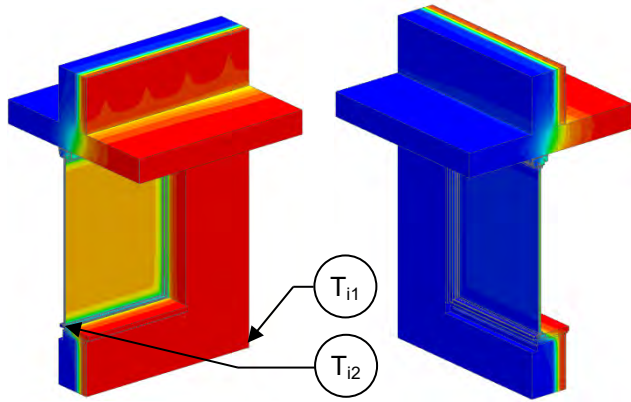

View from Interior

View from Exterior



Assembly 1D (Nominal) R-Value	R_{1D}	R-2.9 (0.51 RSI) + interior insulation
Transmittance / Resistance	U_t, R_t	U and R-values for: t = combined wall + slab + window
Surface Temperature Index ¹	T_i	0 = exterior temperature 1 = interior temperature
Linear Transmittance ²	$\psi_h, \psi_j, \psi_l, \psi_g$	Incremental increase in transmittance per linear length of: h = head j = jamb l = sill g = overall glazing

¹Assumptions and limitations for surface temperatures identified in ASHRAE 1365-RP
²For performance of base assembly and slab linear transmittances, refer to Detail 7.3.3

Scenario

Scenario	Liner Insulation
A, B	None
C, D	R-5 (0.88)

Nominal (1D) vs. Assembly Performance Indicators

Window Transition Transmittance

Scenario	Interior Insulation 1D R-Value (RSI)	R_t ft ² ·hr·°F / Btu (m ² K / W)	U_t Btu/ft ² ·hr·°F (W/m ² K)	ψ_h Btu/ft·hr·°F (W/m K)	ψ_l Btu/ft·hr·°F (W/m K)	ψ_j Btu/ft·hr·°F (W/m K)	ψ_g Btu/ft·hr·°F (W/m K)
A	R-10 (1.76)	R-3.6 (0.64)	0.275 (1.56)	0.091 (0.158)	0.066 (0.114)	0.155 (0.268)	0.111 (0.192)
B	R-15 (2.64)	R-3.8 (0.67)	0.263 (1.49)	0.129 (0.224)	0.088 (0.152)	0.160 (0.277)	0.131 (0.226)
C	R-10 (1.76)	R-3.8 (0.66)	0.265 (1.51)	0.091 (0.158)	0.046 (0.079)	0.076 (0.131)	0.072 (0.124)
D	R-15 (2.64)	R-4.0 (0.70)	0.253 (1.43)	0.129 (0.224)	0.066 (0.113)	0.080 (0.139)	0.090 (0.156)

Temperature Indices

	A	B	C	D	
T_{i1}	0.06	0.05	0.06	0.05	Min T on concrete, away from window slab and studs
T_{i2}	0.28	0.29	0.31	0.32	Min T on window frame, at bottom middle of glazing

Detail 7.3.10

Interior Insulated Concrete Mass Wall with 1 5/8" x 1 5/8" Steel Studs (16" o.c.) Supporting Interior Finish – Window & Projected Slab Intersection with Wall Insulation Wrapped into Opening

Thermal Performance Indicators

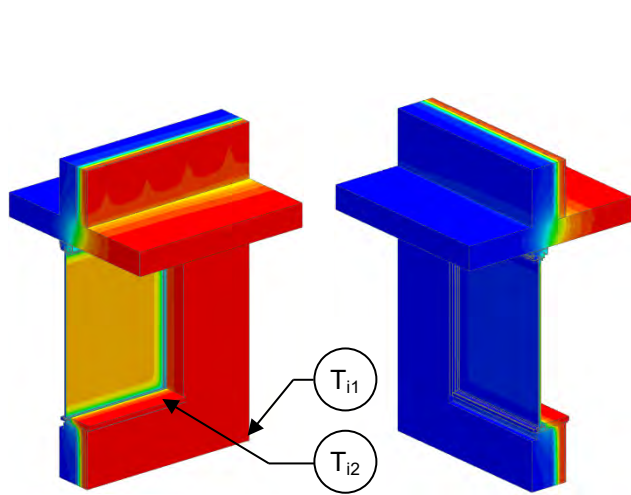

View from Interior

View from Exterior

Assembly 1D (Nominal) R-Value	R_{1D}	R-2.9 (0.51 RSI) + interior insulation
Transmittance / Resistance	U_t, R_t	U and R-values for: t = combined wall + slab + window
Surface Temperature Index ¹	T_i	0 = exterior temperature 1 = interior temperature
Linear Transmittance ²	$\Psi_h, \Psi_j, \Psi_l, \Psi_g$	Incremental increase in transmittance per linear length of: h = head j = jamb l = sill g = overall glazing

¹Assumptions and limitations for surface temperatures identified in ASHRAE 1365-RP

²For performance of base assembly and slab linear transmittances, refer to Detail 7.3.3

Scenario

Scenario	Sill Shim Insulation
A, B, C, D	None
E, F, G, H	Yes

Nominal (1D) vs. Assembly Performance Indicators

Window Transition Transmittance

	Interior Insulation 1D R-Value (RSI)	Opening Insulation 1D R-Value (RSI)	R_t ft ² ·hr·°F / Btu (m ² K / W)	U_t Btu/ft ² ·hr·°F (W/m ² K)	Ψ_h Btu/ft·hr·°F (W/m K)	Ψ_l Btu/ft·hr·°F (W/m K)	Ψ_j Btu/ft·hr·°F (W/m K)	Ψ_g Btu/ft·hr·°F (W/m K)
A	R-10 (1.76)	R-5 (0.88)	R-3.7 (0.65)	0.272 (1.55)	0.091 (0.158)	0.129 (0.223)	0.087 (0.151)	0.100 (0.174)
B	R-15 (2.64)		R-3.9 (0.68)	0.259 (1.47)	0.129 (0.224)	0.142 (0.246)	0.091 (0.157)	0.116 (0.201)
C	R-10 (1.76)	R-10 (1.76)	R-3.7 (0.66)	0.268 (1.52)	0.091 (0.158)	0.085 (0.146)	0.073 (0.127)	0.082 (0.141)
D	R-15 (2.64)		R-3.9 (0.69)	0.254 (1.44)	0.129 (0.224)	0.086 (0.149)	0.076 (0.132)	0.094 (0.163)
E	R-10 (1.76)	R-5 (0.88)	R-3.7 (0.65)	0.270 (1.54)	0.091 (0.158)	0.100 (0.172)	0.087 (0.151)	0.092 (0.159)
F	R-15 (2.64)		R-3.9 (0.68)	0.257 (1.46)	0.129 (0.224)	0.113 (0.196)	0.091 (0.157)	0.108 (0.187)
G	R-10 (1.76)	R-10 (1.76)	R-3.8 (0.66)	0.266 (1.51)	0.091 (0.158)	0.054 (0.093)	0.073 (0.127)	0.073 (0.126)
H	R-15 (2.64)		R-4.0 (0.70)	0.252 (1.43)	0.129 (0.224)	0.057 (0.099)	0.076 (0.132)	0.086 (0.149)

Temperature Indices

	A	B	C	D	E	F	G	H	
T_{i1}	0.06	0.05	0.06	0.05	0.06	0.05	0.06	0.05	Min T on concrete, away from window slab and studs
T_{i2}	0.26	0.25	0.26	0.25	0.30	0.29	0.29	0.28	Min T on window frame, at bottom corner

Detail 7.3.11

Interior Insulated Concrete Mass Wall with 1 5/8" x 1 5/8" Steel Studs (16" o.c.) Supporting Interior Finish – Window & Projected Slab Intersection – Plywood Liner and Glazing Aligned with Wall Insulation

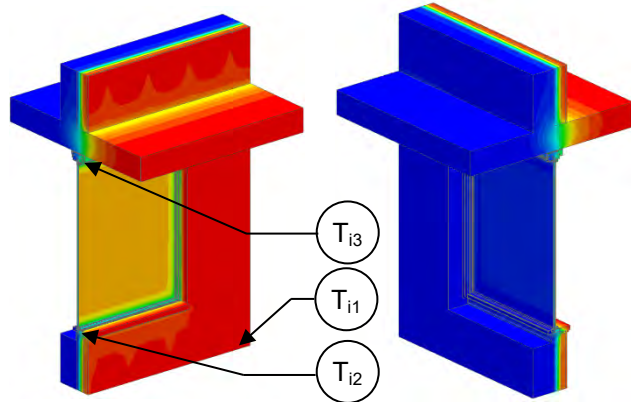

View from Interior

View from Exterior

Thermal Performance Indicators

1.00 0.90 0.80 0.70 0.60 0.50 0.40 0.30 0.20 0.10 0.00	<table border="1"> <tr> <td>Assembly 1D (Nominal) R-Value</td> <td>R_{1D}</td> <td>R-2.9 (0.51 RSI) + interior insulation</td> </tr> <tr> <td>Transmittance / Resistance</td> <td>U_t, R_t</td> <td>U and R-values for: t = combined wall + slab + window</td> </tr> <tr> <td>Surface Temperature Index¹</td> <td>T_i</td> <td>0 = exterior temperature 1 = interior temperature</td> </tr> <tr> <td>Linear Transmittance²</td> <td>$\psi_h, \psi_j, \psi_l, \psi_g$</td> <td>Incremental increase in transmittance per linear length of: h = head j = jamb l = sill g = overall glazing</td> </tr> </table>	Assembly 1D (Nominal) R-Value	R_{1D}	R-2.9 (0.51 RSI) + interior insulation	Transmittance / Resistance	U_t, R_t	U and R-values for: t = combined wall + slab + window	Surface Temperature Index ¹	T_i	0 = exterior temperature 1 = interior temperature	Linear Transmittance ²	$\psi_h, \psi_j, \psi_l, \psi_g$	Incremental increase in transmittance per linear length of: h = head j = jamb l = sill g = overall glazing
Assembly 1D (Nominal) R-Value	R_{1D}	R-2.9 (0.51 RSI) + interior insulation											
Transmittance / Resistance	U_t, R_t	U and R-values for: t = combined wall + slab + window											
Surface Temperature Index ¹	T_i	0 = exterior temperature 1 = interior temperature											
Linear Transmittance ²	$\psi_h, \psi_j, \psi_l, \psi_g$	Incremental increase in transmittance per linear length of: h = head j = jamb l = sill g = overall glazing											

¹Assumptions and limitations for surface temperatures identified in ASHRAE 1365-RP

²For performance of base assembly and slab linear transmittances, refer to Detail 7.3.3

Scenario

Scenario	Sill Shim Insulation
A, B	None
C, D	Yes

Nominal (1D) vs. Assembly Performance Indicators

Window Transition Transmittance

Scenario	Interior Insulation 1D R-Value (RSI)	R_t ft ² ·hr·°F / Btu (m ² K / W)	U_t Btu/ft ² ·hr·°F (W/m ² K)	ψ_h Btu/ft·hr·°F (W/m K)	ψ_l Btu/ft·hr·°F (W/m K)	ψ_j Btu/ft·hr·°F (W/m K)	ψ_g Btu/ft·hr·°F (W/m K)
A	R-10 (1.76)	R-3.8 (0.68)	0.261 (1.48)	0.052 (0.09)	0.068 (0.118)	0.044 (0.076)	0.053 (0.092)
B	R-15 (2.64)	R-4.1 (0.72)	0.246 (1.39)	0.080 (0.139)	0.061 (0.106)	0.051 (0.088)	0.062 (0.107)
C	R-10 (1.76)	R-3.9 (0.69)	0.255 (1.45)	0.052 (0.090)	-0.004 (-0.007)	0.044 (0.076)	0.033 (0.056)
D	R-15 (2.64)	R-4.2 (0.73)	0.240 (1.36)	0.080 (0.139)	-0.023 (-0.040)	0.051 (0.088)	0.038 (0.066)

Temperature Indices

	A	B	C	D	
T_{i1}	0.05	0.04	0.04	0.03	Min T on concrete, away from window slab and studs
T_{i2}	-	-	0.47	0.47	Min T on window frame, at bottom middle of glazing
T_{i3}	0.39	0.39	-	-	Min T on window frame, at top middle of glazing

Detail 7.3.12

Exterior Insulated Concrete Mass Wall with 1 5/8" x 1 5/8" Steel Stud (16" o.c.) and Thermally Isolated Vertical Brackets and Rail System (24" o.c.) Supporting Metal Cladding – Triple Glazed Aluminum Window & Intermediate Floor Intersection with Window Thermal Break Positioned in Concrete Opening

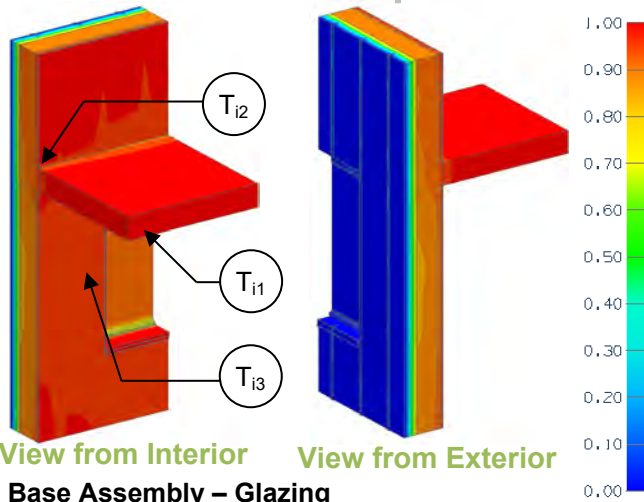

Thermal Performance Indicators

Assembly 1D (Nominal) R-Value	R_{1D}	R-3.4 (0.59 RSI) + exterior insulation
Transmittance / Resistance without Anomaly	U_w, R_w, U_g	"clear wall" U- and R-value: w = wall without intermediate floor g = glazing
Transmittance / Resistance	$U_{floor}, R_{floor}, U_t, R_t$	U and R-values for: floor = wall + intermediate floor t = combined wall + slab + window
Surface Temperature Index ¹	T_i	0 = exterior temperature 1 = interior temperature
Linear Transmittance	ψ	Incremental increase in transmittance per linear length

Base Assembly – Glazing

$U_{\text{centre of glass}}$ Btu/ft ² · hr · °F (W/m ² K)	U_g Btu/ft ² · hr · °F (W/m ² K)
0.142 (0.81)	0.301 (1.72)

¹Assumptions and limitations for surface temperatures identified in ASHRAE 1365-RP

Nominal (1D) vs. Assembly Performance Indicators

Base Assembly – Steel Stud Clear Wall

Exterior Insulation 1D R-Value (RSI)	R_{1D} ft ² ·hr·°F / Btu (m ² K / W)	R_w ft ² ·hr·°F / Btu (m ² K / W)	U_w Btu/ft ² · hr · °F (W/m ² K)
R-10 (1.76)	R-13.4 (2.35)	R-10.9 (1.92)	0.092 (0.52)
R-15 (2.64)	R-18.4 (3.23)	R-13.3 (2.34)	0.075 (0.43)
R-20 (3.52)	R-23.4 (4.11)	R-15.9 (2.80)	0.063 (0.36)
R-25 (4.40)	R-28.4 (4.99)	R-18.3 (3.22)	0.055 (0.31)

Intermediate Floor Linear Transmittance

R_{floor} ft ² ·hr·°F / Btu (m ² K / W)	U_{floor} Btu/ft ² · hr · °F (W/m ² K)	ψ_{floor} Btu/ft ² · hr · °F (W/m ² K)
R-10.4 (1.84)	0.096 (0.55)	0.030 (0.052)
R-12.6 (2.22)	0.079 (0.45)	0.030 (0.051)
R-15.0 (2.65)	0.066 (0.38)	0.026 (0.045)
R-17.3 (3.05)	0.058 (0.33)	0.022 (0.037)

Window Transition Transmittance

Exterior Insulation 1D R-Value (RSI)	R_t ft ² ·hr·°F / Btu (m ² K / W)	U_t Btu/ft ² · hr · °F (W/m ² K)	ψ_{Head} Btu/ft · hr · °F (W/m K)	ψ_{Sill} Btu/ft · hr · °F (W/m K)	ψ_{Jamb} Btu/ft · hr · °F (W/m K)	ψ_{Total} Btu/ft · hr · °F (W/m K)
R-10 (1.76)	R-5.6 (0.99)	0.178 (1.01)	0.247 (0.428)	0.151 (0.261)	0.111 (0.192)	0.190 (0.328)
R-15 (2.64)	R-6.0 (1.05)	0.167 (0.95)	0.257 (0.445)	0.168 (0.291)	0.121 (0.209)	0.202 (0.350)
R-20 (3.52)	R-6.3 (1.10)	0.160 (0.91)	0.268 (0.463)	0.177 (0.306)	0.129 (0.224)	0.212 (0.368)
R-25 (4.40)	R-6.5 (1.14)	0.154 (0.87)	0.274 (0.475)	0.183 (0.316)	0.135 (0.234)	0.218 (0.378)

Temperature Indices

	R10	R15	R20	R25	
T_{i1}	0.43	0.44	0.44	0.44	Min T on window frame, at centre of window head
T_{i3}	0.84	0.86	0.87	0.89	Max T on interior surface of concrete at floor
T_{i4}	0.74	0.75	0.76	0.77	Min T on interior surface of concrete window jamb



Detail 7.3.13

Exterior Insulated Concrete Mass Wall with 1 5/8" x 1 5/8" Steel Stud (16" o.c.) and Thermally Isolated Vertical Brackets and Rail System (24" o.c.) Supporting Metal Cladding – Triple Glazed Aluminum Curtain Wall & Intermediate Floor Intersection with Window Thermal Break Positioned in the Exterior Insulation

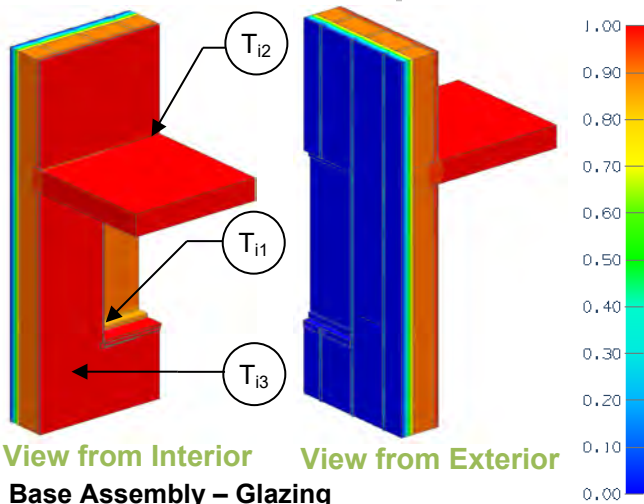

Thermal Performance Indicators

Assembly 1D (Nominal) R-Value	R_{1D}	R-3.4 (0.59 RSI) + exterior insulation
Transmittance / Resistance without Anomaly	U_w, R_w, U_g	"clear wall" U- and R-value: w = wall without intermediate floor g = glazing
Transmittance / Resistance	$U_{floor}, R_{floor}, U_t, R_t$	U and R-values for: floor = wall + intermediate floor t = combined wall + slab + window
Surface Temperature Index ¹	T_i	0 = exterior temperature 1 = interior temperature
Linear Transmittance	Ψ	Incremental increase in transmittance per linear length

Base Assembly – Glazing

$U_{\text{centre of glass}}$ Btu/ft ² · hr · °F (W/m ² K)	U_g Btu/ft ² · hr · °F (W/m ² K)
0.142 (0.81)	0.303 (1.72)

¹Assumptions and limitations for surface temperatures identified in ASHRAE 1365-RP

Nominal (1D) vs. Assembly Performance Indicators

Base Assembly – Steel Stud Clear Wall

Exterior Insulation 1D R-Value (RSI)	R_{1D} ft ² ·hr·°F / Btu (m ² K / W)	R_w ft ² ·hr·°F / Btu (m ² K / W)	U_w Btu/ft ² · hr · °F (W/m ² K)
R-10 (1.76)	R-13.4 (2.35)	R-10.9 (1.92)	0.092 (0.52)
R-15 (2.64)	R-18.4 (3.23)	R-13.3 (2.34)	0.075 (0.43)
R-20 (3.52)	R-23.4 (4.11)	R-15.9 (2.80)	0.063 (0.36)
R-25 (4.40)	R-28.4 (4.99)	R-18.3 (3.22)	0.055 (0.31)

Intermediate Floor Linear Transmittance

R_{floor} ft ² ·hr·°F / Btu (m ² K / W)	U_{floor} Btu/ft ² · hr · °F (W/m ² K)	Ψ_{floor} Btu/ft ² · hr · °F (W/m ² K)
R-10.4 (1.84)	0.096 (0.55)	0.030 (0.052)
R-12.6 (2.22)	0.079 (0.45)	0.030 (0.051)
R-15.0 (2.65)	0.066 (0.38)	0.026 (0.045)
R-17.3 (3.05)	0.058 (0.33)	0.022 (0.037)

Window Transition Transmittance

Exterior Insulation 1D R-Value (RSI)	R_t ft ² ·hr·°F / Btu (m ² K / W)	U_t Btu/ft ² · hr · °F (W/m ² K)	Ψ_{Head} Btu/ft · hr · °F (W/m K)	Ψ_{Sill} Btu/ft · hr · °F (W/m K)	Ψ_{Jamb} Btu/ft · hr · °F (W/m K)	Ψ_{Total} Btu/ft · hr · °F (W/m K)
R-10 (1.76)	R-8.1 (1.42)	0.124 (0.70)	0.038 (0.066)	0.027 (0.046)	0.052 (0.090)	0.015 (0.026)
R-15 (2.64)	R-8.9 (1.57)	0.112 (0.64)	0.040 (0.070)	0.026 (0.045)	0.062 (0.107)	0.024 (0.041)
R-20 (3.52)	R-9.5 (1.67)	0.106 (0.60)	0.046 (0.079)	0.028 (0.049)	0.071 (0.123)	0.040 (0.069)
R-25 (4.40)	R-10.0 (1.76)	0.100 (0.57)	0.051 (0.089)	0.030 (0.052)	0.078 (0.135)	0.047 (0.081)

Temperature Indices

	R-10	R-15	R-20	R-25	
T_{i1}	0.75	0.76	0.76	0.76	Min T on window frame, at bottom corner
T_{i3}	0.89	0.90	0.91	0.92	Max T on interior surface of concrete at floor
T_{i4}	0.82	0.84	0.86	0.87	Min T on interior surface of concrete between steel studs

Detail 7.3.14

Owens Corning Exterior Insulated Concrete Block Wall Assembly with Heckmann Pos-I-Tie Vener Anchoring System Supporting Brick Veneer with Insulation Interrupted at Window Perimeter – Double Glazed Aluminum Window and Intermediate Floor Intersection

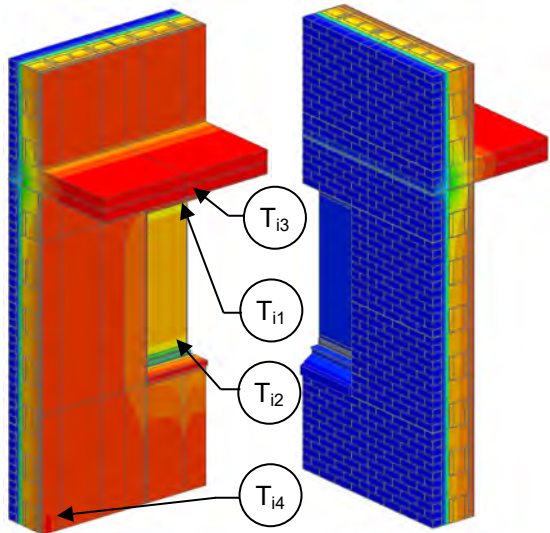

View from Interior View from Exterior

Base Assembly – Glazing

$U_{\text{centre of glass}}$ Btu/ft ² · hr · °F (W/m ² K)	U_g Btu/ft ² · hr · °F (W/m ² K)
0.321 (1.82)	0.408 (2.32)

Thermal Performance Indicators

Assembly 1D (Nominal) R-Value	R_{1D}	R-5.6 (0.99 RSI) + exterior insulation
Transmittance / Resistance without Anomaly	U_w, R_w, U_g	“clear wall” U- and R-value: w = wall without intermediate floor g = glazing
Transmittance / Resistance	$U_{\text{floor}}, R_{\text{floor}}, U_t, R_t$	U and R-values for: floor = wall + intermediate floor t = combined wall + floor + window
Surface Temperature Index ¹	T_i	0 = exterior temperature 1 = interior temperature
Linear Transmittance	ψ	Incremental increase in transmittance per linear length

¹Assumptions and limitations for surface temperatures identified in ASHRAE 1365-RP

Nominal (1D) vs. Assembly Performance Indicators

Base Assembly – Steel Stud Clear Wall

Exterior Insulation 1D R-Value (RSI)	R_{1D} ft ² ·hr·°F / Btu (m ² K / W)	R_w ft ² ·hr·°F / Btu (m ² K / W)	U_w Btu/ft ² · hr · °F (W/m ² K)
R-10.0 (1.76)	R-15.6 (2.75)	R-13.4 (2.36)	0.075 (0.42)
R-20.0 (3.52)	R-25.6 (4.51)	R-20.0 (3.52)	0.050 (0.28)

Intermediate Floor Linear Transmittance

R_{floor} ft ² ·hr·°F / Btu (m ² K / W)	U_{floor} Btu/ft ² · hr · °F (W/m ² K)	ψ_{floor} Btu/ft ² · hr · °F (W/m ² K)
R-8.3 (1.46)	0.121 (0.69)	0.277 (0.480)
R-10.1 (1.78)	0.099 (0.56)	0.292 (0.506)

Window Transition Transmittance

Exterior Insulation 1D R-Value (RSI)	R_t ft ² ·hr·°F / Btu (m ² K / W)	U_t Btu/ft ² · hr · °F (W/m ² K)	ψ_{Head} Btu/ft · hr · °F (W/m K)	ψ_{Sill} Btu/ft · hr · °F (W/m K)	ψ_{Jamb} Btu/ft · hr · °F (W/m K)	ψ_{Total} Btu/ft · hr · °F (W/m K)
R-10.0 (1.76)	R-5.7 (1.00)	0.177 (0.28)	0.141 (0.24)	0.395 (0.68)	0.244 (0.42)	0.431 (0.746)
R-20.0 (3.52)	R-7.1 (1.24)	0.142 (0.28)	0.362 (0.63)	0.131 (0.23)	0.076 (0.13)	0.148 (0.257)

Temperature Indices

	R10	R20	
T_{i1}	0.53	0.43	Min T at centre of window head
T_{i2}	0.47	0.62	Min T at centre of window sill
T_{i3}	0.74	0.75	Min T on interior surface of CMU at ceiling
T_{i4}	0.85	0.90	Max T on interior surface of CMU at steel studs, away from floor

Detail 7.3.15

Owens Corning Exterior Insulated Concrete Block Wall Assembly with Heckmann Pos-I-Tie Vener Anchoring System Supporting Brick Veneer with Reduced Insulation at Jambs – Triple Glazed Aluminum High Performance Window and Intermediate Floor Intersection

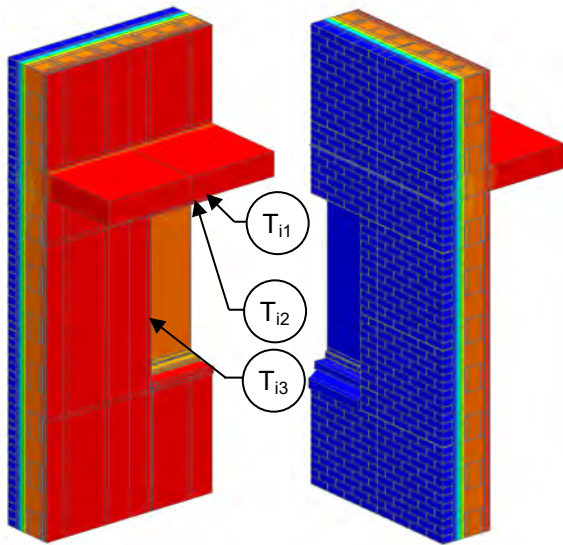

Thermal Performance Indicators

Assembly 1D (Nominal) R-Value	R_{1D}	R-5.6 (0.99 RSI) + exterior insulation
Transmittance / Resistance without Anomaly	U_w, R_w, U_g	“clear wall” U- and R-value: w = wall without intermediate floor g = glazing
Transmittance / Resistance	$U_{floor}, R_{floor}, U_t, R_t$	U and R-values for: floor = wall + intermediate floor t = combined wall + floor + window
Surface Temperature Index ¹	T_i	0 = exterior temperature 1 = interior temperature
Linear Transmittance	ψ	Incremental increase in transmittance per linear length

¹Assumptions and limitations for surface temperatures identified in ASHRAE 1365-RP

View from Interior View from Exterior

Base Assembly – Glazing

$U_{\text{centre of glass}}$ Btu/ft ² · hr · °F (W/m ² K)	U_g Btu/ft ² · hr · °F (W/m ² K)
0.220 (1.25)	0.204 (1.16)

Nominal (1D) vs. Assembly Performance Indicators

Base Assembly – Steel Stud Clear Wall

Exterior Insulation 1D R-Value (RSI)	R_{1D} ft ² ·hr·°F / Btu (m ² K / W)	R_w ft ² ·hr·°F / Btu (m ² K / W)	U_w Btu/ft ² · hr · °F (W/m ² K)
R-10.0 (1.76)	R-15.6 (2.75)	R-13.4 (2.36)	0.075 (0.42)
R-20.0 (3.52)	R-25.6 (4.51)	R-20.0 (3.52)	0.050 (0.28)

Intermediate Floor Linear Transmittance

R_{floor} ft ² ·hr·°F / Btu (m ² K / W)	U_{floor} Btu/ft ² · hr · °F (W/m ² K)	ψ_{floor} Btu/ft ² · hr · °F (W/m ² K)
R-11.7 (2.06)	0.085 (0.48)	0.064 (0.112)
R-16.9 (2.98)	0.059 (0.34)	0.054 (0.093)

Window Transition Transmittance

Exterior Insulation 1D R-Value (RSI)	R_t ft ² ·hr·°F / Btu (m ² K / W)	U_t Btu/ft ² · hr · °F (W/m ² K)	ψ_{Head} Btu/ft · hr · °F (W/m K)	ψ_{Sill} Btu/ft · hr · °F (W/m K)	ψ_{Jamb} Btu/ft · hr · °F (W/m K)	ψ_{Total} Btu/ft · hr · °F (W/m K)
R-10.0 (1.76)	R-9.6 (1.69)	0.104 (0.42)	0.053 (0.09)	0.020 (0.03)	0.082 (0.14)	0.051 (0.088)
R-20.0 (3.52)	R-12.1 (2.12)	0.083 (0.28)	0.142 (0.25)	0.015 (0.03)	0.058 (0.10)	0.058 (0.101)

Temperature Indices

	R10	R20	
T_{i1}	0.81	0.77	Min T on window frame, at centre of window head
T_{i3}	0.86	0.90	Min T on interior surface of CMU at ceiling
T_{i4}	0.91	0.92	Max T on interior surface of CMU, at Jamb

Detail 7.3.16

Interior Insulated Multi-Wythe Brick Masonry Wall with 1 5/8" x 1 5/8" Steel Studs (16" o.c.) Supporting Interior Finish – Wood Window Intersection with Un-Insulated Window Perimeter

Thermal Performance Indicators

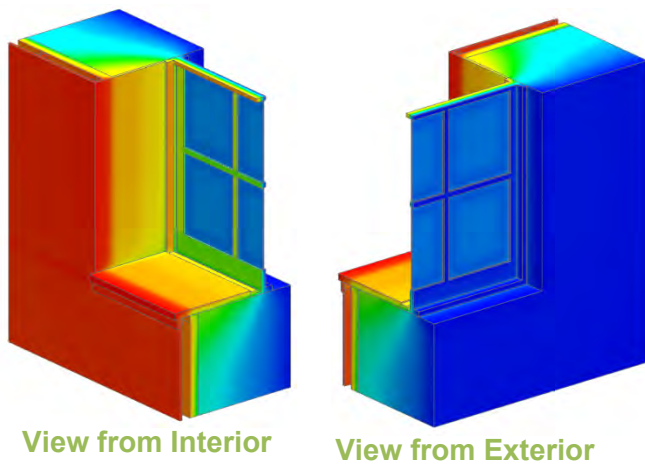

0.00	Assembly 1D (Nominal) R-Value	R_{1D}	R-5.7 (1.00 RSI) + interior insulation
0.10	Transmittance / Resistance without Anomaly	U_w, R_w, U_g	“clear wall” U- and R-value: w = brick wall g = glazing
0.20	Transmittance / Resistance	U R	U- and R-values for overall assembly
0.30	Surface Temperature Index ¹	T_i	0 = exterior temperature 1 = interior temperature
0.40	Linear Transmittance	ψ	Incremental increase in transmittance per linear length of glazing transition
0.50			
0.60			
0.70			
0.80			
0.90			
1.00			

¹Assumptions and limitations for surface temperatures identified in ASHRAE 1365-RP

Nominal (1D) vs. Assembly Performance Indicators

Base Assembly – Wall

Interior Insulation 1D R-Value (RSI)	R_{1D} ft ² ·hr·°F / Btu (m ² K / W)	R_w ft ² ·hr·°F / Btu (m ² K / W)	U_w Btu/ft ² ·hr ·°F (W/m ² K)
R-0 (0.0)	R-5.7 (1.00)	R-5.6 (0.98)	0.180 (1.02)
R-6 (1.76)	R-11.7 (2.06)	R-11.6 (2.04)	0.086 (0.49)
R-12 (2.11)	R-17.7 (3.12)	R-17.6 (3.09)	0.057 (0.32)

Base Assembly – Glazing

$U_{\text{centre of glass}}$ Btu/ft ² ·hr ·°F (W/m ² K)	U_g Btu/ft ² ·hr ·°F (W/m ² K)
1.04 (5.92)	0.79 (4.47)

Window Transition Linear Transmittance

Interior Insulation 1D R-Value (RSI)	R ft ² ·hr·°F / Btu (m ² K / W)	U Btu/ft ² ·hr ·°F (W/m ² K)	ψ Btu/ft hr °F (W/m K)
R-0 (0.0)	R-2.3 (0.41)	0.428 (2.43)	0.172 (0.297)
R-6 (1.76)	R-2.6 (0.45)	0.390 (2.21)	0.260 (0.451)
R-12 (2.11)	R-2.6 (0.47)	0.378 (2.15)	0.292 (0.506)

Detail 7.3.17

Interior Insulated Multi-Wythe Brick Masonry Wall with 1 5/8" x 1 5/8" Steel Studs (16" o.c.) Supporting Interior Finish – Aluminum Window Intersection with Un-insulated window Perimeter

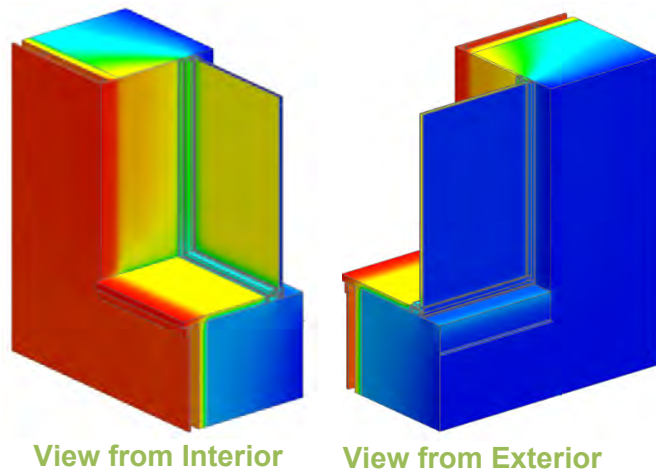

Thermal Performance Indicators

Assembly 1D (Nominal) R-Value	R_{1D}	R-5.7 (1.00 RSI) + interior insulation
Transmittance / Resistance without Anomaly	U_w, R_w, U_g	“clear wall” U- and R-value: w = brick wall g = glazing
Transmittance / Resistance	U R	U- and R-values for overall assembly
Surface Temperature Index ¹	T_i	0 = exterior temperature 1 = interior temperature
Linear Transmittance	ψ	Incremental increase in transmittance per linear length of glazing transition

¹Assumptions and limitations for surface temperatures identified in ASHRAE 1365-RP

Nominal (1D) vs. Assembly Performance Indicators

Base Assembly – Wall

Interior Insulation 1D R-Value (RSI)	R_{1D} ft ² ·hr·°F / Btu (m ² K / W)	R_w ft ² ·hr·°F / Btu (m ² K / W)	U_w Btu/ft ² ·hr ·°F (W/m ² K)
R-0 (0.0)	R-5.7 (1.00)	R-5.6 (0.98)	0.180 (1.02)
R-6 (1.76)	R-11.7 (2.06)	R-11.6 (2.04)	0.086 (0.49)
R-12 (2.11)	R-17.7 (3.12)	R-17.6 (3.09)	0.057 (0.32)

Base Assembly – Glazing

$U_{\text{centre of glass}}$ Btu/ft ² ·hr ·°F (W/m ² K)	U_g Btu/ft ² ·hr ·°F (W/m ² K)
0.321 (1.82)	0.385 (2.19)

Window Transition Linear Transmittance

Interior Insulation 1D R-Value (RSI)	R ft ² ·hr·°F / Btu (m ² K / W)	U Btu/ft ² ·hr ·°F (W/m ² K)	ψ Btu/ft hr °F (W/m K)
R-0 (0.0)	R-3.0 (0.53)	0.334 (1.89)	0.319 (0.552)
R-6 (1.76)	R-3.5 (0.61)	0.289 (1.64)	0.386 (0.668)
R-12 (2.11)	R-3.6 (0.64)	0.275 (1.56)	0.407 (0.704)

Detail 7.3.18

Interior Insulated Multi-Wythe Brick Masonry Wall with 1 5/8" x 1 5/8" Steel Studs (16" o.c.) Supporting Interior Finish– Aluminum Window Intersection with Insulation at Window Perimeter

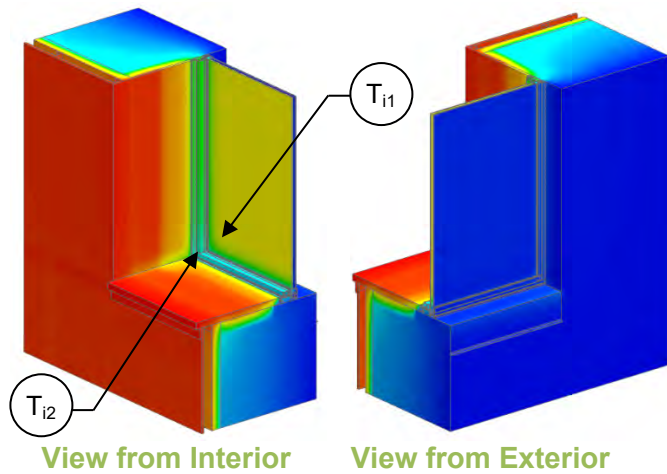

Thermal Performance Indicators

Assembly 1D (Nominal) R-Value	R_{1D}	R-5.7 (1.00 RSI) + interior insulation
Transmittance / Resistance without Anomaly	U_w, R_w, U_g	“clear wall” U- and R-value: w = brick wall g = glazing
Transmittance / Resistance	U R	U- and R-values for overall assembly
Surface Temperature Index ¹	T_i	0 = exterior temperature 1 = interior temperature
Linear Transmittance	ψ	Incremental increase in transmittance per linear length of glazing transition

¹Assumptions and limitations for surface temperatures identified in ASHRAE 1365-RP

Nominal (1D) vs. Assembly Performance Indicators

Base Assembly – Wall

Interior Insulation 1D R-Value (RSI)	R_{1D} ft ² ·hr·°F / Btu (m ² K / W)	R_w ft ² ·hr·°F / Btu (m ² K / W)	U_w Btu/ft ² ·hr ·°F (W/m ² K)
R-12 (2.11)	R-17.7 (3.12)	R-17.6 (3.09)	0.057 (0.32)

Base Assembly – Glazing

$U_{\text{centre of glass}}$ Btu/ft ² ·hr ·°F (W/m ² K)	U_g Btu/ft ² ·hr ·°F (W/m ² K)
0.321 (1.82)	0.385 (2.19)

Window Transition Linear Transmittance

Window Perimeter Scenario	R ft ² ·hr·°F / Btu (m ² K / W)	U Btu/ft ² ·hr ·°F (W/m ² K)	ψ Btu/ft hr °F (W/m K)
Case A: Window on Brick with Insulation at Window Perimeter	R-4.4 (0.78)	0.226 (1.29)	0.225 (0.389)
Case B: Window on Wood Block with Insulation at Window Perimeter	R-4.5 (0.80)	0.221 (1.25)	0.203 (0.352)

Temperature Indices

	Case A	Case B	
T_{i1}	0.52	0.57	Min T on window glass, in lower corner
T_{i2}	0.65	0.66	Min T on window frame, in lower corner

Detail 7.3.19

Interior Insulated Brick Masonry Wall with 1 5/8" x 1 5/8" Steel Studs (16" o.c.) Supporting Interior Finish – Aluminum Window Intersection with Aerogel Blanket at Window Perimeter

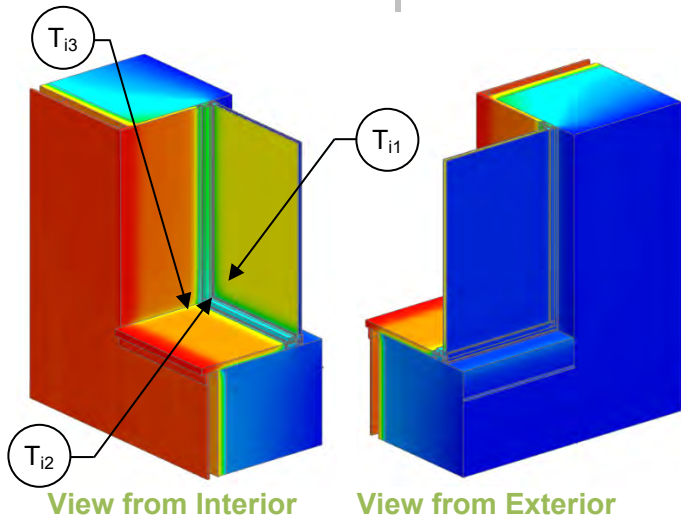

Thermal Performance Indicators

Assembly 1D (Nominal) R-Value	R_{1D}	R-5.7 (1.00 RSI) + interior insulation
Transmittance / Resistance without Anomaly	U_w, R_w, U_g	“clear wall” U- and R-value: w = brick wall g = glazing
Transmittance / Resistance	U R	U- and R-values for overall assembly
Surface Temperature Index ¹	T_i	0 = exterior temperature 1 = interior temperature
Linear Transmittance	ψ	Incremental increase in transmittance per linear length of glazing transition

¹Assumptions and limitations for surface temperatures identified in ASHRAE 1365-RP

Nominal (1D) vs. Assembly Performance Indicators

Base Assembly – Wall

Interior Insulation 1D R-Value (RSI)	R_{1D} ft ² ·hr·°F / Btu (m ² K / W)	R_w ft ² ·hr·°F / Btu (m ² K / W)	U_w Btu/ft ² ·hr·°F (W/m ² K)
R-12 (2.11)	R-17.7 (3.12)	R-17.6 (3.09)	0.057 (0.32)

Base Assembly – Glazing

$U_{\text{centre of glass}}$ Btu/ft ² ·hr·°F (W/m ² K)	U_g Btu/ft ² ·hr·°F (W/m ² K)
0.321 (1.82)	0.385 (2.19)

Window Transition Linear Transmittance

R ft ² ·hr·°F / Btu (m ² K / W)	U Btu/ft ² ·hr·°F (W/m ² K)	ψ Btu/ft hr °F (W/m K)
R-4.3 (0.76)	0.233 (1.32)	0.249 (0.432)

Temperature Indices

T_{i1}	0.36	Min T on window glass, in lower corner
T_{i2}	0.63	Min T on window frame, in lower corner
T_{i3}	0.20	Min T on brick at window sill, in lower corner

Detail 7.3.20

Precast Sandwich Panel Wall Assembly with PVC at Panel Perimeter, Steel Connectors at 24" (o.c.), and 3 5/8" Steel Stud (16" o.c.) – Window Intersection

Thermal Performance Indicators

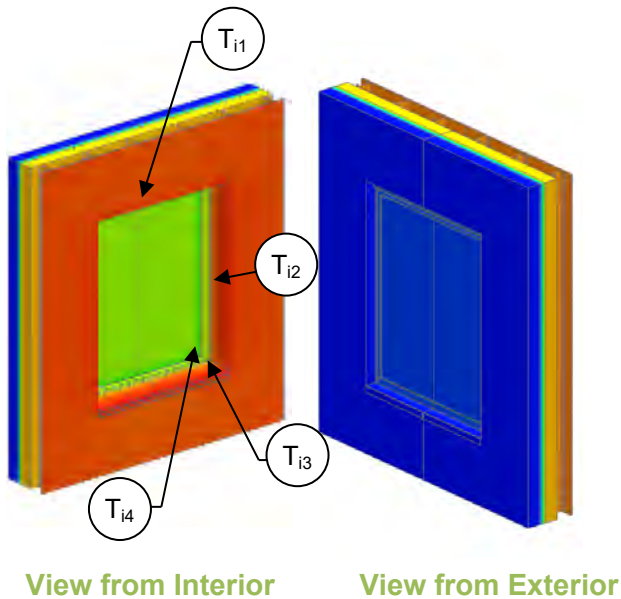

Assembly 1D (Nominal) R-Value	R_{1D}	R-3.9 (0.69 RSI) + sandwich panel insulation
Transmittance / Resistance without Anomaly	U_w , R_w , U_g	"clear wall" U- and R-value: w = sandwich panel g = glazing
Transmittance / Resistance	U_t , R_t	U and R-values for combined wall and window
Surface Temperature Index ¹	T_i	0 = exterior temperature 1 = interior temperature
Linear Transmittance	Ψ_h , Ψ_j , Ψ_l , Ψ_g	Incremental increase in transmittance per linear length of: h = head j = jamb l = sill g = overall glazing

¹Assumptions and limitations for surface temperatures identified in ASHRAE 1365-RP

Nominal (1D) vs. Assembly Performance Indicators

Base Assembly – Precast Clear Wall

Sandwich Panel Insulation 1D R-Value (RSI)	R_{1D} ft ² ·hr·°F / Btu (m ² K / W)	R_w ft ² ·hr·°F / Btu (m ² K / W)	U_w Btu/ft ² ·hr ·°F (W/m ² K)
R-10 (1.76)	R-13.9 (2.45)	R-12.6 (2.22)	0.079 (0.45)
R-15 (2.64)	R-18.9 (3.33)	R-17.2 (3.03)	0.058 (0.33)
R-20 (3.52)	R-23.9 (4.21)	R-22.4 (3.94)	0.045 (0.25)

Base Assembly - Glazing

$U_{\text{centre of glass}}$ Btu/ft ² ·hr ·°F (W/m ² K)	U_g Btu/ft ² ·hr ·°F (W/m ² K)
0.321 (1.82)	0.400 (2.27)

Window Transition Transmittance

Sandwich Panel Insulation 1D R-Value (RSI)	R_t ft ² ·hr·°F / Btu (m ² K / W)	U_t Btu/ft ² ·hr ·°F (W/m ² K)	Ψ_h Btu/ft ·hr ·°F (W/m K)	Ψ_l Btu/ft ·hr ·°F (W/m K)	Ψ_j Btu/ft ·hr ·°F (W/m K)	Ψ_g Btu/ft ·hr ·°F (W/m K)
R-10 (1.76)	R-5.1 (0.90)	0.197 (1.12)	0.057 (0.098)	0.063 (0.109)	0.027 (0.047)	0.047 (0.081)
R-15 (2.64)	R-5.5 (0.98)	0.180 (1.02)	0.052 (0.090)	0.063 (0.110)	0.020 (0.035)	0.040 (0.069)
R-20 (3.52)	R-5.9 (0.96)	0.168 (0.96)	0.039 (0.067)	0.065 (0.112)	0.017 (0.030)	0.030 (0.051)

Temperature Indices

	R10	R15	R20	
T_{i1}	0.82	0.87	0.91	Min T on concrete wall, centered above window head
T_{i2}	0.85	0.89	0.88	Max T on concrete wall, at steel stud and window frame
T_{i3}	0.55	0.54	0.54	Min T on window frame, at bottom corner
T_{i4}	0.62	0.62	0.62	Min T on window glass, in lower corner

Detail 7.3.21

Precast Sandwich Panel Wall Assembly with Wood at Panel Perimeter, Steel Connectors at 24" (o.c.), and 3 5/8" Steel Stud (16" o.c.) – Window Intersection

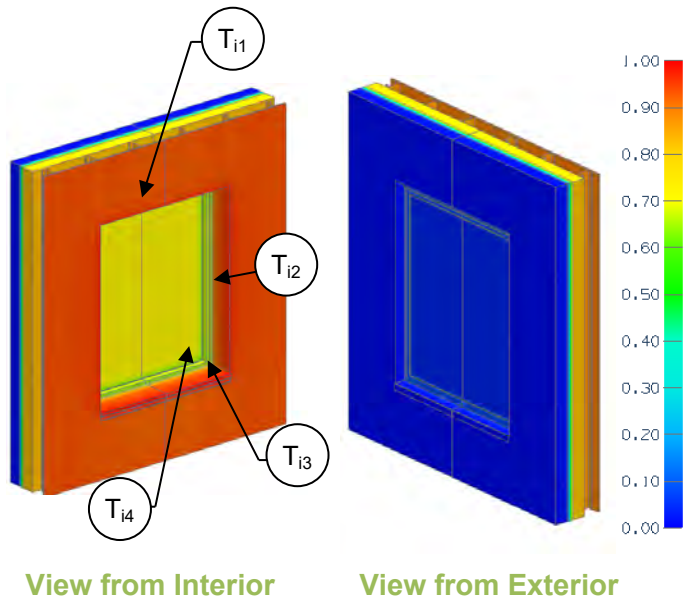

Thermal Performance Indicators

Assembly 1D (Nominal) R-Value	R_{1D}	R-3.9 (0.69 RSI) + sandwich panel insulation
Transmittance / Resistance without Anomaly	U_w , R_w , U_g	"clear wall" U- and R-value: w = sandwich panel g = glazing
Transmittance / Resistance	U_t , R_t	U and R-values for combined wall and window
Surface Temperature Index ¹	T_i	0 = exterior temperature 1 = interior temperature
Linear Transmittance	Ψ_h , Ψ_j , Ψ_l , Ψ_g	Incremental increase in transmittance per linear length of: h = head j = jamb l = sill g = overall glazing

¹Assumptions and limitations for surface temperatures identified in ASHRAE 1365-RP

Nominal (1D) vs. Assembly Performance Indicators

Base Assembly – Precast Clear Wall

Sandwich Panel Insulation 1D R-Value (RSI)	R_{1D} ft ² ·hr·°F / Btu (m ² K / W)	R_w ft ² ·hr·°F / Btu (m ² K / W)	U_w Btu/ft ² ·hr ·°F (W/m ² K)
R-10 (1.76)	R-13.9 (2.45)	R-12.6 (2.22)	0.079 (0.45)
R-15 (2.64)	R-18.9 (3.33)	R-17.2 (3.03)	0.058 (0.33)
R-20 (3.52)	R-23.9 (4.21)	R-22.4 (3.94)	0.045 (0.25)

Base Assembly - Glazing

$U_{\text{centre of glass}}$ Btu/ft ² ·hr ·°F (W/m ² K)	U_g Btu/ft ² ·hr ·°F (W/m ² K)
0.321 (1.82)	0.400 (2.27)

Window Transition Transmittance

Sandwich Panel Insulation 1D R-Value (RSI)	R_t ft ² ·hr·°F / Btu (m ² K / W)	U_t Btu/ft ² ·hr ·°F (W/m ² K)	Ψ_h Btu/ft ·hr ·°F (W/m K)	Ψ_l Btu/ft ·hr ·°F (W/m K)	Ψ_j Btu/ft ·hr ·°F (W/m K)	Ψ_g Btu/ft ·hr ·°F (W/m K)
R-10 (1.76)	R-5.0 (0.88)	0.201 (1.14)	0.068 (0.118)	0.073 (0.126)	0.041 (0.072)	0.061 (0.105)
R-15 (2.64)	R-5.5 (0.96)	0.183 (1.04)	0.062 (0.107)	0.070 (0.121)	0.033 (0.057)	0.051 (0.088)
R-20 (3.52)	R-5.8 (1.03)	0.171 (0.97)	0.048 (0.083)	0.071 (0.122)	0.028 (0.048)	0.040 (0.069)

Temperature Indices

	R10	R15	R20	
T_{i1}	0.81	0.86	0.91	Min T on concrete wall, centered above window head
T_{i2}	0.87	0.91	0.89	Max T on concrete wall, at steel stud and window frame
T_{i3}	0.58	0.57	0.56	Min T on window frame, at bottom corner
T_{i4}	0.62	0.62	0.61	Min T on window glass, in lower corner

Detail 7.3.22

Precast Sandwich Panel Wall Assembly with Gypsum Board at Panel Perimeter, Steel Connectors at 24" (o.c.), and 3 5/8" Steel Stud (16" o.c.) – Window Intersection

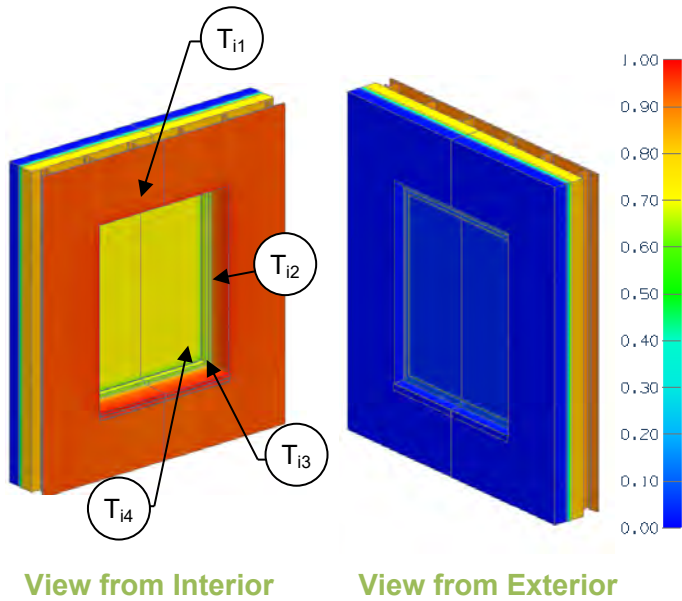

Thermal Performance Indicators

Assembly 1D (Nominal) R-Value	R_{1D}	R-3.9 (0.69 RSI) + sandwich panel insulation
Transmittance / Resistance without Anomaly	U_w, R_w, U_g	“clear wall” U- and R-value: w = sandwich panel g = glazing
Transmittance / Resistance	U_t, R_t	U and R-values for combined wall and window
Surface Temperature Index ¹	T_i	0 = exterior temperature 1 = interior temperature
Linear Transmittance	$\psi_h, \psi_j, \psi_l, \psi_g$	Incremental increase in transmittance per linear length of: h = head j = jamb l = sill g = overall glazing

¹Assumptions and limitations for surface temperatures identified in ASHRAE 1365-RP

Nominal (1D) vs. Assembly Performance Indicators

Base Assembly – Precast Clear Wall

Sandwich Panel Insulation 1D R-Value (RSI)	R_{1D} ft ² ·hr·°F / Btu (m ² K / W)	R_w ft ² ·hr·°F / Btu (m ² K / W)	U_w Btu/ft ² ·hr ·°F (W/m ² K)
R-10 (1.76)	R-13.9 (2.45)	R-12.6 (2.22)	0.079 (0.45)
R-15 (2.64)	R-18.9 (3.33)	R-17.2 (3.03)	0.058 (0.33)
R-20 (3.52)	R-23.9 (4.21)	R-22.4 (3.94)	0.045 (0.25)

Base Assembly - Glazing

$U_{\text{centre of glass}}$ Btu/ft ² ·hr ·°F (W/m ² K)	U_g Btu/ft ² ·hr ·°F (W/m ² K)
0.321 (1.82)	0.400 (2.27)

Window Transition Transmittance

Sandwich Panel Insulation 1D R-Value (RSI)	R_t ft ² ·hr·°F / Btu (m ² K / W)	U_t Btu/ft ² ·hr ·°F (W/m ² K)	ψ_h Btu/ft ·hr ·°F (W/m K)	ψ_l Btu/ft ·hr ·°F (W/m K)	ψ_j Btu/ft ·hr ·°F (W/m K)	ψ_g Btu/ft ·hr ·°F (W/m K)
R-10.0 (1.76)	R-4.9 (0.87)	0.203 (1.15)	0.073 (0.126)	0.076 (0.132)	0.046 (0.079)	0.068 (0.117)
R-15.0 (2.64)	R-5.4 (0.95)	0.185 (1.05)	0.066 (0.113)	0.074 (0.128)	0.037 (0.064)	0.056 (0.097)
R-20.0 (3.52)	R-5.8 (1.03)	0.172 (0.97)	0.052 (0.090)	0.073 (0.127)	0.031 (0.054)	0.042 (0.072)

Temperature Indices

	R10	R15	R20	
T_{i1}	0.81	0.86	0.90	Min T on concrete wall, centered above window head
T_{i2}	0.86	0.91	0.90	Max T on concrete wall, at steel stud and window frame
T_{i3}	0.57	0.57	0.57	Min T on window frame, at bottom corner
T_{i4}	0.62	0.62	0.61	Min T on window glass, in lower corner

Detail 7.3.23

Precast Sandwich Panel Wall Assembly, Steel Connectors at 24" (o.c.), and 3 5/8" Steel Stud (16" o.c.) – Window Intersection

Thermal Performance Indicators

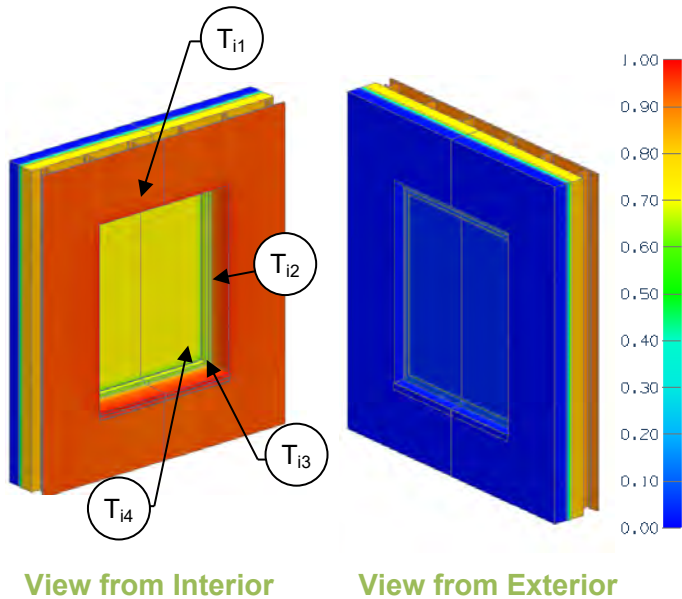

Assembly 1D (Nominal) R-Value	R_{1D}	R-3.9 (0.69 RSI) + sandwich panel insulation
Transmittance / Resistance without Anomaly	U_w, R_w, U_g	“clear wall” U- and R-value: w = sandwich panel g = glazing
Transmittance / Resistance	U_t, R_t	U and R-values for combined wall and window
Surface Temperature Index ¹	T_i	0 = exterior temperature 1 = interior temperature
Linear Transmittance	$\Psi_h, \Psi_j, \Psi_l, \Psi_g$	Incremental increase in transmittance per linear length of: h = head j = jamb l = sill g = overall glazing

¹Assumptions and limitations for surface temperatures identified in ASHRAE 1365-RP

Nominal (1D) vs. Assembly Performance Indicators

Base Assembly – Precast Clear Wall

Sandwich Panel Insulation 1D R-Value (RSI)	R_{1D} ft ² ·hr·°F / Btu (m ² K / W)	R_w ft ² ·hr·°F / Btu (m ² K / W)	U_w Btu/ft ² ·hr ·°F (W/m ² K)
R-10.0 (1.76)	R-13.9 (2.45)	R-12.6 (2.22)	0.079 (0.45)
R-15.0 (2.64)	R-18.9 (3.33)	R-17.2 (3.03)	0.058 (0.33)
R-20.0 (3.52)	R-23.9 (4.21)	R-22.4 (3.94)	0.045 (0.25)

Base Assembly - Glazing

$U_{\text{centre of glass}}$ Btu/ft ² ·hr ·°F (W/m ² K)	U_g Btu/ft ² ·hr ·°F (W/m ² K)
0.321 (1.82)	0.400 (2.27)

Window Transition Transmittance

Sandwich Panel Insulation 1D R-Value (RSI)	R_t ft ² ·hr·°F / Btu (m ² K / W)	U_t Btu/ft ² ·hr ·°F (W/m ² K)	Ψ_h Btu/ft ·hr ·°F (W/m K)	Ψ_l Btu/ft ·hr ·°F (W/m K)	Ψ_j Btu/ft ·hr ·°F (W/m K)	Ψ_g Btu/ft ·hr ·°F (W/m K)
R-10.0 (1.76)	R-5.0 (0.89)	0.198 (1.13)	0.055 (0.095)	0.074 (0.127)	0.029 (0.050)	0.052 (0.091)
R-15.0 (2.64)	R-5.5 (0.97)	0.182 (1.03)	0.062 (0.107)	0.097 (0.167)	0.027 (0.046)	0.044 (0.076)
R-20.0 (3.52)	R-5.6 (0.99)	0.179 (1.01)	0.071 (0.123)	0.133 (0.230)	0.042 (0.072)	0.065 (0.113)

Temperature Indices

	R10	R15	R20	
T_{i1}	0.81	0.87	0.87	Min T on concrete wall, centered above window head
T_{i2}	0.87	0.93	0.87	Max T on concrete wall, at steel stud and window frame
T_{i3}	0.58	0.57	0.57	Min T on window frame, at bottom corner
T_{i4}	0.62	0.62	0.62	Min T on window glass, in lower corner

Detail 7.4.1

Exterior Insulated Concrete Drained EIFS Wall Assembly – Conventional Curtain Wall Transition

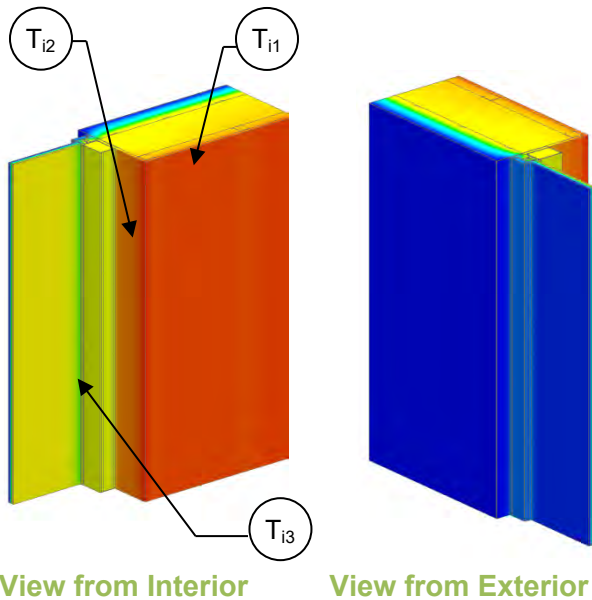

Thermal Performance Indicators

Assembly 1D (Nominal) R-Value	R_{1D}	R-3.0 (0.53 RSI) + exterior insulation
Transmittance / Resistance without Anomaly	U_g, U_w, R_w	“clear wall” U- and R-value for: g = curtain wall glazing w = concrete assembly
Transmittance / Resistance	U, R	U- and R-values for overall assembly
Surface Temperature Index ¹	T_i	0 = exterior temperature 1 = interior temperature
Linear Transmittance	Ψ	Incremental increase in transmittance per linear length of curtain wall transition

¹Assumptions and limitations for surface temperatures identified in ASHRAE 1365-RP

Nominal (1D) vs. Assembly Performance Indicators

Base Assembly – Wall

Exterior Insulation 1D R-Value (RSI)	R_{1D} ft ² ·hr·°F / Btu (m ² K / W)	R_w ft ² ·hr·°F / Btu (m ² K / W)	U_w Btu/ft ² ·hr ·°F (W/m ² K)
R-15 (2.64)	R-18.0 (3.17)	R-17.6 (3.10)	0.057 (0.32)

Base Assembly – Curtain Wall Glazing

$U_{\text{centre of glazing}}$ Btu/ft ² ·hr ·°F (W/m ² K)	U_g Btu/ft ² ·hr ·°F (W/m ² K)
0.321 (1.82)	0.476 (2.70)

Curtain Wall Transition Linear Transmittance

Exterior Insulation 1D R-Value (RSI)	R ft ² ·hr·°F / Btu (m ² K / W)	U Btu/ft ² ·hr ·°F (W/m ² K)	Ψ Btu/ft hr °F (W/m K)
R-15 (2.64)	R-4.4 (0.78)	0.227 (1.29)	0.059 (0.103)

Temperature Indices

T_{i1}	0.79	Min T on concrete interior face, between steel studs
T_{i2}	0.87	Max T on concrete, at drywall return
T_{i3}	0.58	Min T on curtain wall, at glass

Detail 7.4.2

Precast Sandwich Panel Wall Assembly with 3 5/8" Steel Stud (16" o.c.) – Curtain Wall Spandrel Transition

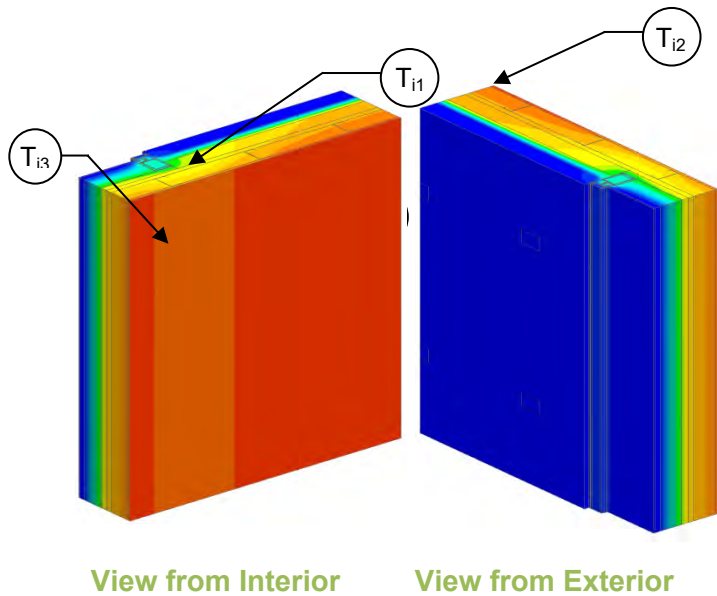

Thermal Performance Indicators

Assembly 1D (Nominal) R-Value	R_{1Dw} , R_{1Dcw}	Nominal thermal resistance of two base assemblies: w = concrete wall cw = curtain wall
Transmittance / Resistance without Anomaly	U_w , R_w , U_{cw} , R_{cw}	“clear wall” U- and R-value for the two base assemblies
Transmittance / Resistance	U, R	U- and R-values for overall assembly
Surface Temperature Index ¹	T_i	0 = exterior temperature 1 = interior temperature
Linear Transmittance	ψ	Incremental increase in transmittance per linear length of transition joint

¹Assumptions and limitations for surface temperatures identified in ASHRAE 1365-RP

Nominal (1D) vs. Assembly Performance Indicators

Base Assembly – Wall

R_{1Dw} ft ² ·hr·°F / Btu (m ² K / W)	R_w ft ² ·hr·°F / Btu (m ² K / W)	U_w Btu/ft ² ·hr ·°F (W/m ² K)
R-13.9 (2.45)	R-12.6 (2.22)	0.079 (0.45)

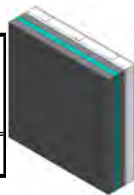

Base Assembly – Curtain Wall²

R_{1Dcw} ft ² ·hr·°F / Btu (m ² K / W)	R_{cw} ft ² ·hr·°F / Btu (m ² K / W)	U_{cw} Btu/ft ² ·hr ·°F (W/m ² K)
R-19.2 (3.38)	R-5.7 (1.01)	0.175 (0.99)

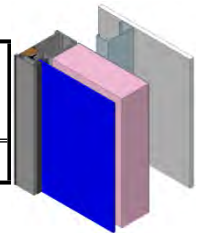

² R-15 back pan insulation

Transition Joint Linear Transmittance

R ft ² ·hr·°F / Btu (m ² K / W)	U Btu/ft ² ·hr ·°F (W/m ² K)	ψ Btu/ft hr °F (W/m K)
R-8.0 (1.41)	0.125 (0.71)	0.082 (0.142)

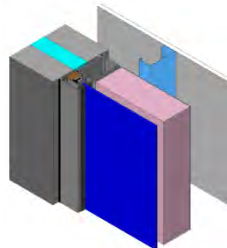

Temperature Indices

T_{i1}	0.62	Min T on interior concrete wall, at mullion
T_{i2}	0.83	Max T on interior concrete wall, away from mullion
T_{i3}	0.43	Min T in air cavity, at mullion

Detail 7.4.3

Interior Insulated Concrete Mass Wall – Conventional Curtain Wall Transition

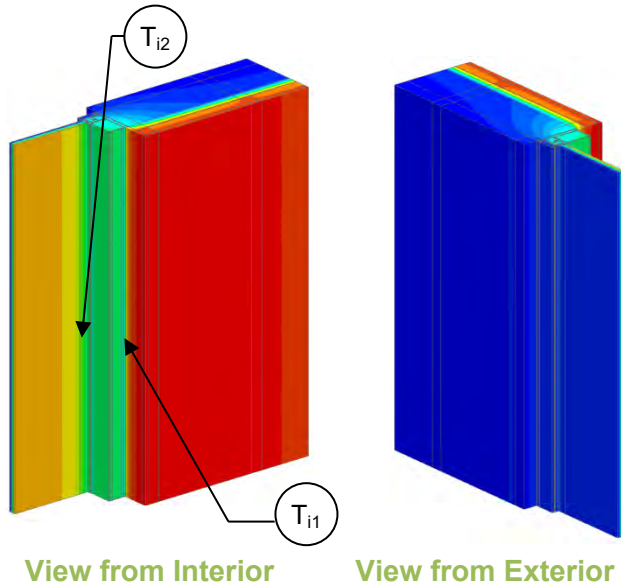

Thermal Performance Indicators

Assembly 1D (Nominal) R-Value	R_{1D}	R-2.9 (0.50 RSI) + exterior insulation
Transmittance / Resistance without Anomaly	U_g , U_w , R_w	“clear wall” U- and R-value for: g = curtain wall w = concrete assembly
Transmittance / Resistance	U, R	U- and R-values for overall assembly
Surface Temperature Index ¹	T_i	0 = exterior temperature 1 = interior temperature
Linear Transmittance	Ψ	Incremental increase in transmittance per linear length of curtain wall transition

¹Assumptions and limitations for surface temperatures identified in ASHRAE 1365-RP

Nominal (1D) vs. Assembly Performance Indicators

Base Assembly – Wall

Exterior Insulation 1D R-Value (RSI)	R_{1D} ft ² ·hr·°F / Btu (m ² K / W)	R_w ft ² ·hr·°F / Btu (m ² K / W)	U_w Btu/ft ² ·hr ·°F (W/m ² K)
R-10 (1.76)	R-13.0 (2.29)	R-12.9 (2.26)	0.078 (0.44)

Base Assembly – Curtain Wall Glazing

$U_{\text{centre of glazing}}$ Btu/ft ² ·hr ·°F (W/m ² K)	U_g Btu/ft ² ·hr ·°F (W/m ² K)
0.321 (1.82)	0.476 (2.70)

Curtain Wall Transition Linear Transmittance

Exterior Insulation 1D R-Value (RSI)	R ft ² ·hr·°F / Btu (m ² K / W)	U Btu/ft ² ·hr ·°F (W/m ² K)	Ψ Btu/ft hr °F (W/m K)
R-10 (1.76)	R-3.7 (0.64)	0.274 (1.55)	0.171 (0.295)

Temperature Indices

T_{i1}	0.44	Min T on frame
T_{i2}	0.43	Min T on glazing

Detail 7.4.4

Interior Insulated Concrete Mass Wall – Thermally Broken Curtain Wall Transition

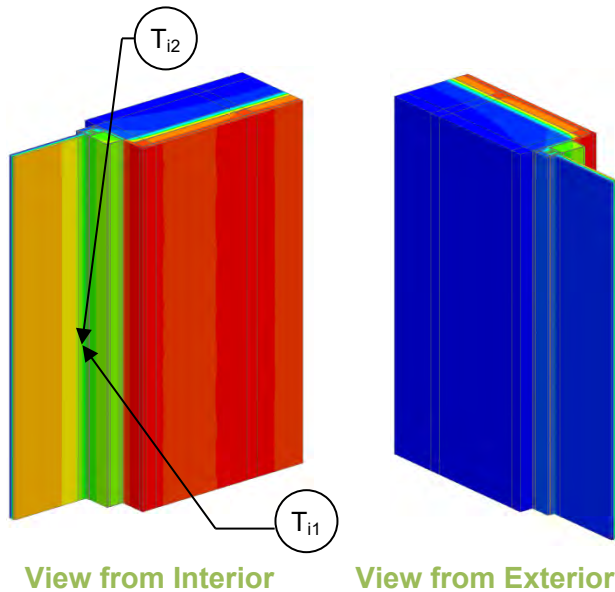

Thermal Performance Indicators

Assembly 1D (Nominal) R-Value	R_{1D}	R-2.9 (0.50 RSI) + exterior insulation
Transmittance / Resistance without Anomaly	U_g, U_w, R_w	“clear wall” U- and R-value for: g = curtain wall w = concrete assembly
Transmittance / Resistance	U, R	U- and R-values for overall assembly
Surface Temperature Index ¹	T_i	0 = exterior temperature 1 = interior temperature
Linear Transmittance	ψ	Incremental increase in transmittance per linear length of curtain wall transition

¹Assumptions and limitations for surface temperatures identified in ASHRAE 1365-RP

Nominal (1D) vs. Assembly Performance Indicators

Base Assembly – Wall

Exterior Insulation 1D R-Value (RSI)	R_{1D} ft ² ·hr·°F / Btu (m ² K / W)	R_w ft ² ·hr·°F / Btu (m ² K / W)	U_w Btu/ft ² ·hr ·°F (W/m ² K)
R-10 (1.76)	R-13.0 (2.29)	R-12.9 (2.26)	0.078 (0.44)

Base Assembly – Curtain Wall

$U_{\text{centre of glazing}}$ Btu/ft ² ·hr ·°F (W/m ² K)	U_g Btu/ft ² ·hr ·°F (W/m ² K)
0.321 (1.82)	0.476 (2.70)

Curtain Wall Transition Linear Transmittance

Exterior Insulation 1D R-Value (RSI)	R ft ² ·hr·°F / Btu (m ² K / W)	U Btu/ft ² ·hr ·°F (W/m ² K)	ψ Btu/ft hr °F (W/m K)
R-10 (1.76)	R-4.2 (0.74)	0.237 (1.34)	0.050 (0.086)

Temperature Indices

T_{i1}	0.52	Min T on frame
T_{i2}	0.50	Min T on glazing

Detail 7.4.5

Precast Sandwich Panel Wall Assembly – Tigerloc Thermally Broken Curtain Wall Transition

Thermal Performance Indicators

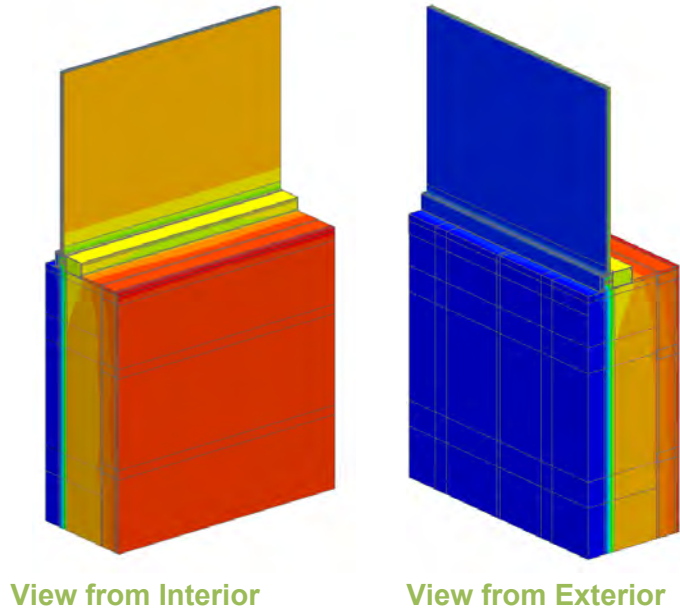

Assembly 1D (Nominal) R-Value	R_{1D}	Nominal thermal resistance of wall
Transmittance / Resistance without Anomaly	U_w, R_w, U_g	“clear field” U- and R-value for: w = wall without panel joint g = glazing
Transmittance / Resistance	U_j, R_j, U_{cw}, R_{cw}	U- and R-values for: j = wall with joint panel cw = curtain wall
Surface Temperature Index ¹	T_i	0 = exterior temperature 1 = interior temperature
Linear Transmittance	Ψ_j, Ψ_{cw}	Incremental increase in transmittance per linear length of anomaly

¹Assumptions and limitations for surface temperatures identified in ASHRAE 1365-RP

Nominal (1D) vs. Assembly Performance Indicators

Base Assembly – Wall

Sandwich Panel Insulation 1D R-value (RSI)	R_{1D} ft ² ·hr·°F / Btu (m ² K / W)	R_w ft ² ·hr·°F / Btu (m ² K / W)	U_w Btu/ft ² ·hr·°F (W/m ² K)
R-10 (1.76)	R-13.1 (2.31)	R-12.8 (2.26)	0.078 (0.44)
R-15 (2.64)	R-18.1 (3.19)	R-17.7 (3.12)	0.056 (0.32)
R-20 (3.52)	R-23.1 (4.07)	R-22.6 (3.98)	0.044 (0.25)

Base Assembly – Curtain Wall Glazing

$U_{\text{centre of glazing}}$ Btu/ft ² ·hr·°F (W/m ² K)	U_g Btu/ft ² ·hr·°F (W/m ² K)
0.32 (1.82)	0.389 (2.21)

Panel Joint Linear Transmittance

Sandwich Panel Insulation 1D R-value (RSI)	R_j ft ² ·hr·°F / Btu (m ² K / W)	U_j Btu/ft ² ·hr·°F (W/m ² K)	Ψ_j Btu/ft·hr·°F (W/m K)
R-10 (1.76)	R-9.3 (1.65)	0.107 (0.61)	0.099 (0.17)
R-15 (2.64)	R-12.0 (2.11)	0.084 (0.47)	0.092 (0.16)
R-20 (3.52)	R-14.5 (2.56)	0.069 (0.39)	0.084 (0.15)

Curtain Wall Transition Linear Transmittance

Sandwich Panel Insulation 1D R-value (RSI)	R_{cw} ft ² ·hr·°F / Btu (m ² K / W)	U_{cw} Btu/ft ² ·hr·°F (W/m ² K)	Ψ_{cw} Btu/ft·hr·°F (W/m K)
R-10 (1.76)	R-4.2 (0.75)	0.236 (1.34)	0.041 (0.071)
R-15 (2.64)	R-4.5 (0.79)	0.224 (1.27)	0.044 (0.076)
R-20 (3.52)	R-4.6 (0.82)	0.215 (1.22)	0.044 (0.077)

Detail 7.4.6

Highly Insulated Precast Concrete Sandwich Panel Wall Assembly – High Performance Aluminum Window Sill Detail

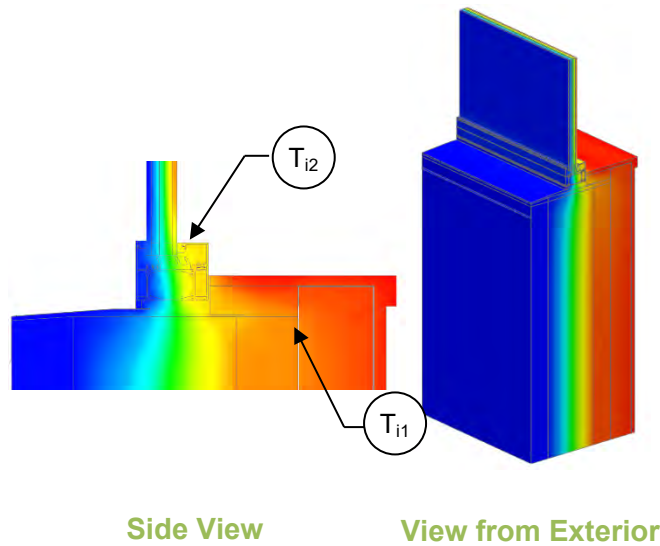

Thermal Performance Indicators

Assembly 1D (Nominal) R-Value	R_{1D}	R-2.76 (0.49 RSI) + insulation
Transmittance / Resistance without Anomaly	U_w, R_w, U_g, R_g	“clear field” U- and R-value w = wall g = glazing
Transmittance / Resistance	U, R	U- and R-values for the overall assembly
Linear Transmittance	Ψ	Incremental increase in transmittance for sill detail

Scenarios

Scenario	Sill Detail Insulation
A	Spray foam below frame and mineral wool behind frame
B	Aerogel below frame and mineral wool behind frame
C	Spray foam below frame and no insulation behind frame

Nominal (1D) vs. Assembly Performance Indicators

Base Assembly – Wall

Wall Insulation R-Value/in	Wall Insulation 1D R-Value (RSI)	R_{1D} ft ² ·hr·°F / Btu (m ² K / W)	R_w ft ² ·hr·°F / Btu (m ² K / W)	U_w Btu/ft ² ·hr·°F (W/m ² K)
5	R-40 (7.04)	R-42.8 (7.53)	R-42.3 (7.45)	0.024 (0.13)
6	R-48 (8.45)	R-50.8 (8.94)	R-50.3 (8.86)	0.020 (0.11)
7	R-56 (9.86)	R-58.8 (10.35)	R-58.3 (10.27)	0.017 (0.10)

Base Assembly – Glazing

$U_{\text{centre of glazing}}$ Btu/ft ² ·hr·°F (W/m ² K)	U_{frame} Btu/ft ² ·hr·°F (W/m ² K)	Ψ_{spacer} Btu/ft·hr·°F (W/m K)	U_g Btu/ft ² ·hr·°F (W/m ² K)
0.123 (0.70)	0.261 (1.48)	0.040 (0.069)	0.172 (0.98)

Sill Linear Transmittance

Scenario	Wall Insulation R-Value/in	Wall Insulation 1D R-Value (RSI)	R ft ² ·hr·°F / Btu (m ² K / W)	U Btu/ft ² ·hr·°F (W/m ² K)	Ψ Btu/ft·hr·°F (W/mK)
A	5	R-42.8 (7.53)	R-13.7 (2.41)	0.073 (0.42)	0.009 (0.016)
	6	R-50.8 (8.94)	R-14.1 (2.49)	0.071 (0.40)	0.010 (0.018)
	7	R-58.8 (10.35)	R-14.5 (2.55)	0.069 (0.39)	0.011 (0.019)
B	6	R-50.8 (8.94)	R-14.2 (2.50)	0.070 (0.40)	0.008 (0.015)
C	6	R-50.8 (8.94)	R-14.0 (2.46)	0.072 (0.41)	0.014 (0.023)

Temperature Indices

	A R42.8	A R50.8	A R58.8	B R50.8	C R50.8	
T_{i1}	0.91	0.91	0.92	0.92	0.92	Min T on interior concrete precast sandwich panel surface, below window between studs
T_{i2}	0.80	0.80	0.80	0.81	0.83	Min T on window frame, at edge of glass

Detail 7.4.7

Highly Insulated Precast Concrete Sandwich Panel Wall Assembly – High Performance Aluminum Window Head Detail

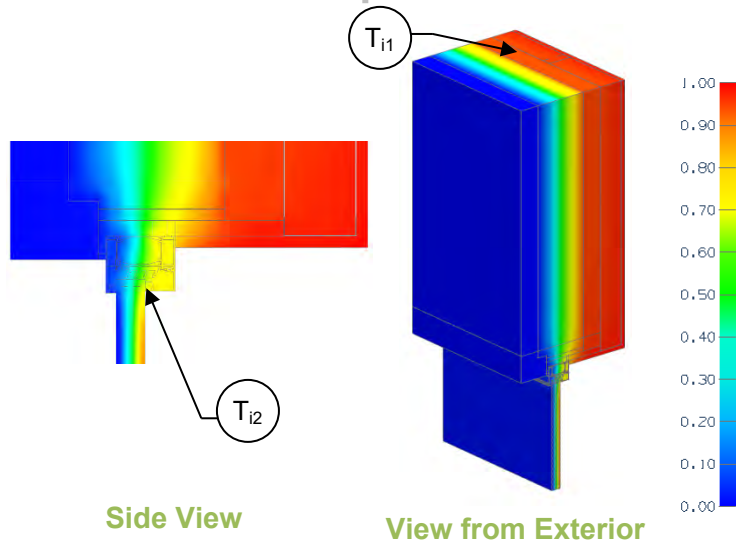

Thermal Performance Indicators

Assembly 1D (Nominal) R-Value	R_{1D}	R-2.76 (0.49 RSI) + insulation
Transmittance / Resistance without Anomaly	U_w, R_w, U_g, R_g	“clear field” U- and R-value w = wall g = glazing
Transmittance / Resistance	U, R	U- and R-values for the overall assembly
Linear Transmittance	Ψ	Incremental increase in transmittance for sill detail

Scenarios

Scenario	Head/Jamb Detail Insulation
A	Spray Foam around opening
B	Aerogel around opening

Nominal (1D) vs. Assembly Performance Indicators

Base Assembly – Wall

Wall Insulation R-Value/in	Wall Insulation 1D R-Value (RSI)	R_{1D} ft ² ·hr·°F / Btu (m ² K / W)	R_w ft ² ·hr·°F / Btu (m ² K / W)	U_w Btu/ft ² ·hr ·°F (W/m ² K)
5	R-40 (7.04)	R-42.8 (7.53)	R-42.3 (7.45)	0.024 (0.13)
6	R-48 (8.45)	R-50.8 (8.94)	R-50.3 (8.86)	0.020 (0.11)
7	R-56 (9.86)	R-58.8 (10.35)	R-58.3 (10.27)	0.017 (0.10)

Base Assembly – Glazing

$U_{\text{centre of glazing}}$ Btu/ft ² ·hr ·°F (W/m ² K)	U_{frame} Btu/ft ² ·hr ·°F (W/m ² K)	Ψ_{spacer} Btu/ft ·hr ·°F (W/m K)	U_g Btu/ft ² ·hr ·°F (W/m ² K)
0.123 (0.70)	0.261 (1.48)	0.040 (0.069)	0.172 (0.98)

Head and Jamb Linear Transmittance

Scenario	Wall Insulation R-Value/in	Wall Insulation 1D R-Value (RSI)	R ft ² ·hr·°F / Btu (m ² K / W)	U Btu/ft ² ·hr ·°F (W/m ² K)	Ψ Btu/ft·hr·°F (W/mK)
A	5	R-42.8 (7.53)	R-13.9 (2.44)	0.072 (0.41)	0.004 (0.007)
	6	R-50.8 (8.94)	R-14.4 (2.53)	0.070 (0.40)	0.004 (0.007)
	7	R-58.8 (10.35)	R-14.7 (2.60)	0.068 (0.39)	0.005 (0.008)
B	6	R-50.8 (8.94)	R-14.4 (2.54)	0.069 (0.39)	0.003 (0.006)

Temperature Indices

	A R42.8	A R50.8	A R58.8	B R50.8	
T_{i1}	0.95	0.96	0.96	0.96	Min T on interior concrete precast sandwich panel surface, away from window between studs
T_{i2}	0.77	0.77	0.77	0.77	Min T on window frame, at edge of glass

Detail 7.5.1

Exterior Insulated Concrete Drained EIFS Wall Assembly – Concrete Parapet & Slab Intersection

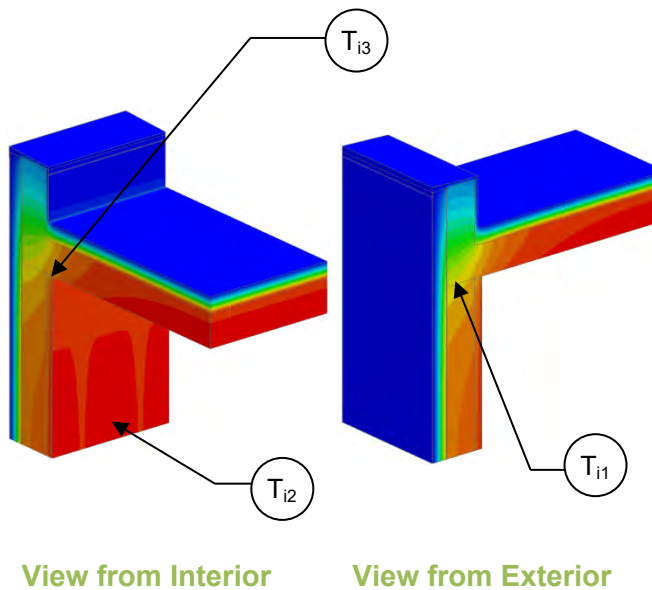

Thermal Performance Indicators

Assembly 1D (Nominal) R-Value	R_{1D}	R-3.0 (0.53 RSI) + exterior insulation
Transmittance / Resistance without Anomaly	U_r, R_r, U_w, R_w	“clear wall” U- and R-value: r = roof w = wall
Transmittance / Resistance	U, R	U- and R-values for overall assembly
Surface Temperature Index ¹	T_i	0 = exterior temperature 1 = interior temperature
Linear Transmittance	ψ	Incremental increase in transmittance per linear length of parapet

¹Assumptions and limitations for surface temperatures identified in ASHRAE 1365-RP

Nominal (1D) vs. Assembly Performance Indicators

Base Assembly – Wall

Exterior Insulation 1D R-Value (RSI)	R_{1D} ft ² ·hr·°F / Btu (m ² K / W)	R_w ft ² ·hr·°F / Btu (m ² K / W)	U_w Btu/ft ² ·hr ·°F (W/m ² K)
R-15 (2.64)	R-18.0 (3.17)	R-17.6 (3.10)	0.057 (0.32)

Base Assembly - Roof

Roof Exterior Insulation 1D R-Value (RSI)	R_r ft ² hr °F / Btu (m ² K / W)	U_r Btu/ft ² ·hr ·°F (W/m ² K)
R-20 (3.52)	R-21.9 (3.86)	0.046 (0.26)

Parapet Linear Transmittance

Exterior Insulation 1D R-Value (RSI)	R ft ² ·hr·°F / Btu (m ² K / W)	U Btu/ft ² ·hr ·°F (W/m ² K)	ψ Btu/ft hr °F (W/m K)
R-15 (2.64)	R-12.2 (2.14)	0.082 (0.47)	0.252 (0.436)

Temperature Indices

T_{i1}	0.77	Min T on concrete interior surface, at concrete roof slab intersection
T_{i2}	0.88	Max T on concrete interior surface at mid-wall
T_{i3}	0.82	Min T on concrete ceiling, at drywall intersection, exposed to interior air

Detail 7.5.2

Exterior Insulated Concrete Drained EIFS Wall Assembly – Insulated Concrete Parapet & Slab Intersection

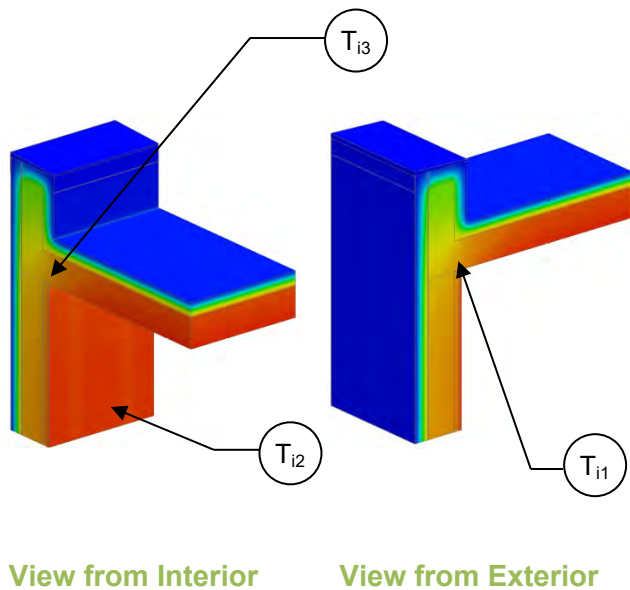

Thermal Performance Indicators

Assembly 1D (Nominal) R-Value	R_{1D}	R-3.0 (0.53 RSI) + exterior insulation
Transmittance / Resistance without Anomaly	U_r, R_r, U_w, R_w	“clear wall” U- and R-value: r = roof w = wall
Transmittance / Resistance	U, R	U- and R-values for overall assembly
Surface Temperature Index ¹	T_i	0 = exterior temperature 1 = interior temperature
Linear Transmittance	ψ	Incremental increase in transmittance per linear length of parapet

¹Assumptions and limitations for surface temperatures identified in ASHRAE 1365-RP

Nominal (1D) vs. Assembly Performance Indicators

Base Assembly – Wall

Exterior Insulation 1D R-Value (RSI)	R_{1D} ft ² ·hr·°F / Btu (m ² K / W)	R_w ft ² ·hr·°F / Btu (m ² K / W)	U_w Btu/ft ² ·hr·°F (W/m ² K)
R-15 (2.64)	R-18.0 (3.17)	R-17.6 (3.10)	0.057 (0.32)

Base Assembly - Roof

Roof Exterior Insulation 1D R-Value (RSI)	R_r ft ² hr °F / Btu (m ² K / W)	U_r Btu/ft ² ·hr·°F (W/m ² K)
R-20 (3.52)	R-21.9 (3.86)	0.046 (0.26)

Parapet Linear Transmittance

Exterior Insulation 1D R-Value (RSI)	R ft ² ·hr·°F / Btu (m ² K / W)	U Btu/ft ² ·hr·°F (W/m ² K)	ψ Btu/ft hr °F (W/m K)
R-15 (2.64)	R-14.5 (2.55)	0.069 (0.39)	0.146 (0.253)

Temperature Indices

T_{i1}	0.83	Min T on concrete interior surface, at concrete roof slab intersection
T_{i2}	0.89	Max T on concrete interior surface, at mid-wall
T_{i3}	0.87	Min T on concrete ceiling, at drywall intersection, exposed to interior air

Detail 7.5.3

Interior Insulated Concrete Mass Wall with 1 5/8" Steel Stud (16" o.c) Supporting Interior Finish – Concrete Parapet & Roof Intersection

Thermal Performance Indicators

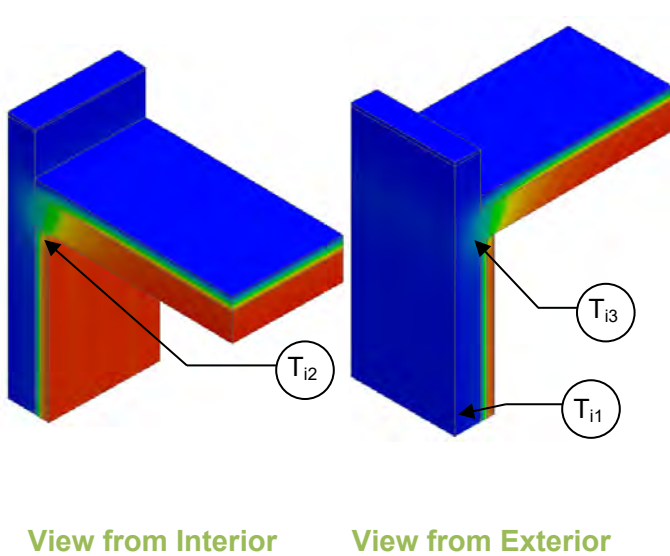

Assembly 1D (Nominal) R-Value	R_{1D}	Nominal thermal resistance of wall assembly
Transmittance / Resistance without Anomaly	U_r, R_r, U_w, R_w	"clear field" U- and R-values: r = roof w = wall
Transmittance / Resistance	U, R	U- and R-values for overall assembly
Surface Temperature Index ¹	T_i	0 = exterior temperature 1 = interior temperature
Linear Transmittance	ψ	Incremental increase in transmittance per linear length of parapet

¹Assumptions and limitations for surface temperatures identified in ASHRAE 1365-RP

Nominal (1D) vs. Assembly Performance Indicators

Base Assembly – Wall

R_{1D} ft ² ·hr·°F / Btu (m ² K / W)	R_w ft ² ·hr·°F / Btu (m ² K / W)	U_w Btu/ft ² ·hr·°F (W/m ² K)
R-13.9 (2.44)	R-13.5 (2.37)	0.074 (0.42)

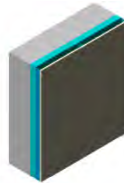

Base Assembly – Roof

Roof Exterior Insulation 1D R-Value (RSI)	R_r ft ² ·hr·°F / Btu (m ² K / W)	U_r Btu/ft ² ·hr·°F (W/m ² K)
R-20 (3.52)	R-21.9 (3.86)	0.046 (0.26)

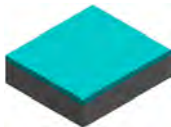

Parapet Linear Transmittance

R ft ² ·hr·°F / Btu (m ² K / W)	U Btu/ft ² ·hr·°F (W/m ² K)	ψ Btu/ft hr °F (W/m K)
R-8.94 (1.57)	0.112 (0.64)	0.449 (0.777)

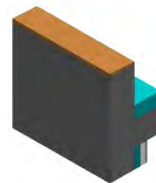

Temperature Indices

T_{i1}	0.06	Min T on concrete wall, between studs, away from ceiling
T_{i2}	0.27	Max T on concrete wall, at wall/roof intersection
T_{i3}	0.59	Min T on interior ceiling, at gypsum board, between studs

Detail 7.5.4

Precast Sandwich Panel Wall Assembly with 3 5/8" Steel Stud (16" o.c.) – Steel Roof Deck with Open Web Steel Joist & Parapet Intersection

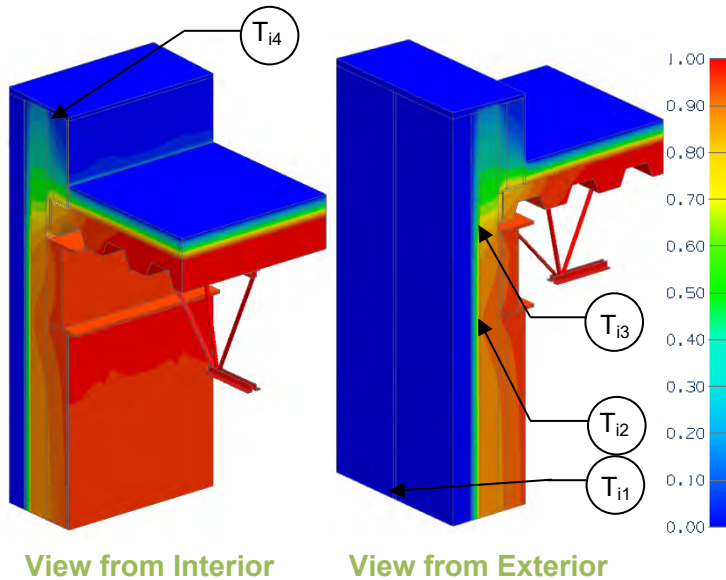

Thermal Performance Indicators

Assembly 1D (Nominal) R-Value	R_{1D}	R-3.9 (0.69 RSI) + sandwich panel insulation
Transmittance / Resistance without Anomaly	U_r, R_r, U_w, R_w	"clear field" U- and R-values: r = roof w = wall
Transmittance / Resistance	U_j, R_j, U_p, R_p	U- and R-values for: j = panel joint p = parapet
Surface Temperature Index ¹	T_i	0 = exterior temperature 1 = interior temperature
Linear Transmittance	Ψ_j, Ψ_p	Incremental increase in transmittance per linear length of anomaly

¹Assumptions and limitations for surface temperatures identified in ASHRAE 1365-RP

Nominal (1D) vs. Assembly Performance Indicators

Base Assembly – Wall

R_{1Dw} ft ² ·hr·°F / Btu (m ² K / W)	R_w ft ² ·hr·°F / Btu (m ² K / W)	U_w Btu/ft ² ·hr·°F (W/m ² K)
R-13.9 (2.45)	R-12.6 (2.22)	0.079 (0.45)

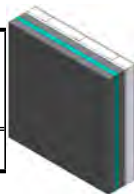

Panel Joint Linear Transmittance

R_j ft ² ·hr·°F / Btu (m ² K / W)	U_j Btu/ft ² ·hr·°F (W/m ² K)	Ψ_j Btu/ft hr °F (W/m K)
R-11.7(2.05)	0.086 (0.49)	0.026 (0.046)



Base Assembly - Roof

Roof Exterior Insulation 1D R-Value (RSI)	R_r ft ² hr °F / Btu (m ² K / W)	U_r Btu/ft ² ·hr·°F (W/m ² K)
R-20 (3.52)	R-21.9 (3.86)	0.046(0.26)

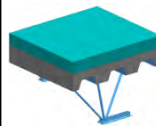

Parapet Linear Transmittance

R_p ft ² ·hr·°F / Btu (m ² K / W)	U_p Btu/ft ² ·hr·°F (W/m ² K)	Ψ_p Btu/ft hr °F (W/m K)
R-8.2 (1.43)	0.123 (0.70)	0.375 (0.650)

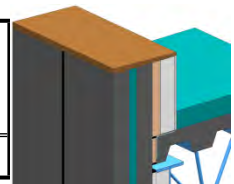

Temperature Indices

T_{i1}	0.82	Min T on concrete wall, at panel joint, away from roof
T_{i2}	0.89	Max T on concrete wall, below l-beam
T_{i3}	0.77	Min T in interior surface, on concrete, away from joist
T_{i4}	0.19	Min T on concrete parapet, and panel edge and wood block

Detail 7.5.5

Precast Sandwich Panel – Steel Roof Deck with Open Web Steel Joist & Parapet Intersection

Thermal Performance Indicators

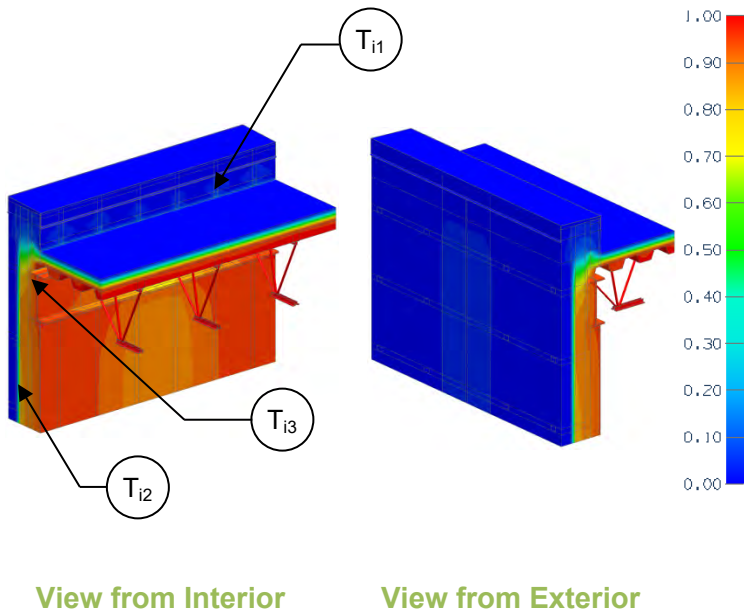

Assembly 1D (Nominal) R-Value	R_{1D}	R-3.9 (0.69 RSI) + sandwich panel insulation
Transmittance / Resistance without Anomaly	U_r, R_r, U_w, R_w	“clear wall” U- and R-values: r = roof w = sandwich panel
Transmittance / Resistance	U_j, R_j, U_p, R_p	U and R-values for: j = sandwich panel with panel joint p = parapet
Surface Temperature Index ¹	T_i	0 = exterior temperature 1 = interior temperature
Linear Transmittance	Ψ_j, Ψ_p	Incremental increase in transmittance per linear length of: j = panel joint p = parapet transition

¹Assumptions and limitations for surface temperatures identified in ASHRAE 1365-RP

Nominal (1D) vs. Assembly Performance Indicators

Base Assembly – Wall

Sandwich Panel Insulation 1D R-Value (RSI)	R_{1D} ft ² ·hr·°F / Btu (m ² K / W)	R_w ft ² ·hr·°F / Btu (m ² K / W)	U_w Btu/ft ² ·hr ·°F (W/m ² K)
R-10 (1.76)	R-13.9 (2.45)	R-12.6 (2.22)	0.079 (0.45)

Panel Joint Linear Transmittance

R_j ft ² ·hr·°F / Btu (m ² K / W)	U_j Btu/ft ² ·hr ·°F (W/m ² K)	Ψ_j Btu/ft ·hr·°F (W/m K)
R-6.2 (1.10)	0.160 (0.91)	0.653 (1.130)

Base Assembly – Roof

Roof Exterior Insulation 1D R-Value (RSI)	R_r ft ² hr °F / Btu (m ² K / W)	U_r Btu/ft ² ·hr ·°F (W/m ² K)
R-20 (3.52)	R-21.9 (3.86)	0.046 (0.26)

Parapet Linear Transmittance

Sandwich Panel Insulation 1D R-Value (RSI)	R_p ft ² ·hr·°F / Btu (m ² K / W)	U_p Btu/ft ² ·hr ·°F (W/m ² K)	Ψ_p Btu/ft ·hr·°F (W/m K)
R-10 (1.76)	R-5.6 (0.99)	0.178 (1.01)	0.483 (0.836)

Temperature Indices

T_{i1}	0.36	Min T on sandwich panel, at concrete edge and roof insulation intersection
T_{i2}	0.85	Max T on sandwich panel, at centre of panel away from concrete edges
T_{i3}	0.53	Min T on roof sheathing, along sandwich panel intersection

Detail 7.5.6

Precast Wall Assembly with 3 5/8" x 1 5/8" Steel Stud (16" o.c) and Rigid Insulation Outboard of Studs – Parapet & Roof Intersection

Thermal Performance Indicators

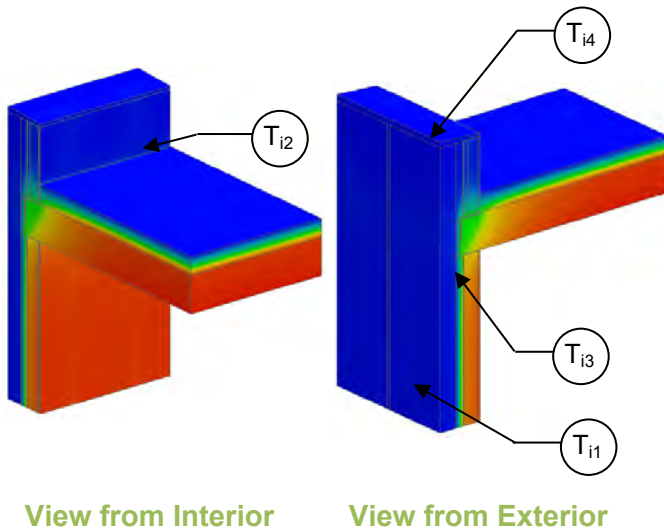

Assembly 1D (Nominal) R-Value	R_{1D}	Nominal thermal resistance
Transmittance / Resistance without Anomaly	U_r, R_r, U_w, R_w	"clear field" U- and R-values: r = roof w = wall
Transmittance / Resistance	U, R	U and R-values for the assembly
Surface Temperature Index ¹	T_i	0 = exterior temperature 1 = interior temperature
Linear Transmittance	ψ	Incremental increase in transmittance per linear length of parapet

¹Assumptions and limitations for surface temperatures identified in ASHRAE 1365-RP

Nominal (1D) vs. Assembly Performance Indicators

Base Assembly – Wall

R_{1D} ft ² ·hr·°F / Btu (m ² K / W)	R_w ft ² ·hr·°F / Btu (m ² K / W)	U_w Btu/ft ² ·hr·°F (W/m ² K)
R-13.0 (2.29)	R-12.9 (2.26)	0.078 (0.44)

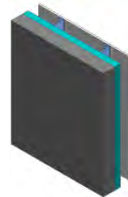

Base Assembly - Roof

Roof Exterior Insulation 1D R-Value (RSI)	R_r ft ² hr °F / Btu (m ² K / W)	U_r Btu/ft ² ·hr ·°F (W/m ² K)
R-20 (3.52)	R-21.9 (3.86)	0.046 (0.26)

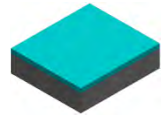

Parapet Linear Transmittance

R ft ² ·hr·°F / Btu (m ² K / W)	U Btu/ft ² ·hr ·°F (W/m ² K)	ψ Btu/ft hr °F (W/m K)
R-9.1 (1.60)	0.110 (0.63)	0.334 (0.579)

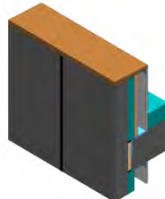

² Panel edges (caulked joints between panels) had negligible linear transmittance effects so values not presented

Temperature Indices

T_{i1}	0.04	Min T on concrete wall, between studs, away from roof
T_{i2}	0.16	Max T on concrete wall, at slot anchor
T_{i3}	0.73	Min T on ceiling, at gypsum board, at studs
T_{i4}	0.01	Min T on concrete parapet, at wood blocking

Detail 7.5.7

Precast Wall Assembly with 3 5/8" x 1 5/8" Steel Stud (16" o.c) and Rigid Insulation Outboard of Studs – Parapet & Roof Intersection with Thermal Break under Parapet Stud Cavity and At Anchors

Thermal Performance Indicators

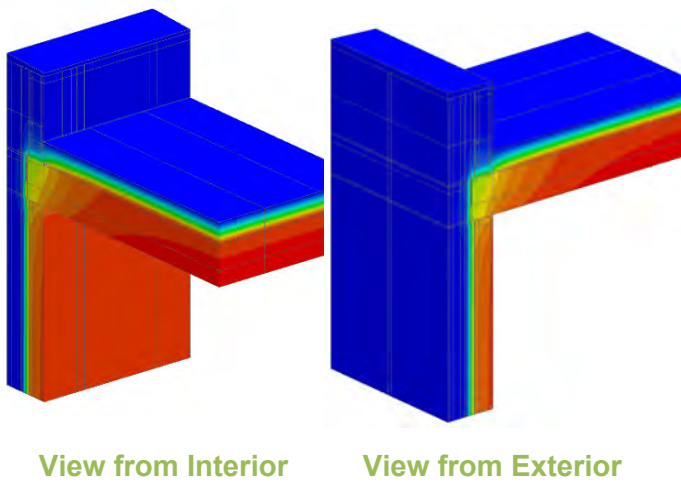

Assembly 1D (Nominal) R-Value	R_{1D}	R-2.8 (0.49 RSI) + Exterior Insulation for wall
Transmittance / Resistance without Anomaly	U_r, R_r, U_w, R_w	“clear field” U- and R-values: r = roof w = wall
Transmittance / Resistance	U, R	U and R-values for overall assembly
Surface Temperature Index	T_i	0 = exterior temperature 1 = interior temperature
Linear Transmittance	ψ	Incremental increase in transmittance per linear length of parapet

¹Assumptions and limitations for surface temperatures identified in ASHRAE 1365-RP

Scenario

Scenario	
A	Armatherm 500 beneath stud cavity
B	Armatherm 500 beneath stud cavity, 3/8" FRR at anchors

Nominal (1D) vs. Assembly Performance Indicators

Base Assembly – Wall

Exterior Insulation 1D R-Value (RSI)	R_{1D} ft ² ·hr·°F / Btu (m ² K / W)	R_w ft ² ·hr·°F / Btu (m ² K / W)	U_w Btu/ft ² ·hr ·°F (W/m ² K)
R-10 (1.76)	R-12.8 (2.25)	R-12.2 (2.15)	0.082 (0.47)

Base Assembly - Roof

Roof Exterior Insulation 1D R-Value (RSI)	R_r ft ² hr °F / Btu (m ² K / W)	U_r Btu/ft ² ·hr ·°F (W/m ² K)
R-20 (3.52)	R-21.9 (3.86)	0.046 (0.26)

Parapet Linear Transmittance

Scenario	R ft ² ·hr·°F / Btu (m ² K / W)	U Btu/ft ² ·hr ·°F (W/m ² K)	ψ Btu/ft hr °F (W/m K)
A	R-10.6 (1.86)	0.095 (0.54)	0.227 (0.393)
B	R-10.7 (1.89)	0.093 (0.53)	0.125 (0.216)

Panel edges (caulked joints between panels) had negligible linear transmittance effects so values not presented

Detail 7.5.8

Exterior Insulated Concrete Block Wall Assembly with Masonry Ties Supporting Brick Veneer – Parapet & Roof Intersection

Thermal Performance Indicators

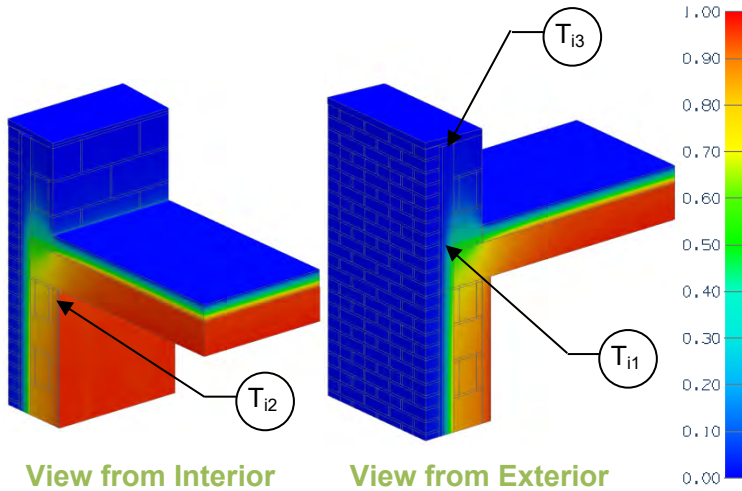

Assembly 1D (Nominal) R-Value	R_{1D}	R-5.6 (0.97 RSI) + exterior insulation
Transmittance / Resistance without Anomaly	U_r, R_r, U_w, R_w	“clear field” U- and R-values: r = roof w = wall
Transmittance / Resistance	U, R	U and R-values for the assembly
Surface Temperature Index ¹	T_i	0 = exterior temperature 1 = interior temperature
Linear Transmittance	ψ	Incremental increase in transmittance per linear length of parapet

¹Assumptions and limitations for surface temperatures identified in ASHRAE 1365-RP

Nominal (1D) vs. Assembly Performance Indicators

Base Assembly – Wall

Exterior Insulation 1D R-Value (RSI)	R_{1D} ft ² ·hr·°F / Btu (m ² K / W)	R_w ft ² ·hr·°F / Btu (m ² K / W)	U_w Btu/ft ² ·hr ·°F (W/m ² K)
R-5 (0.88)	R-10.6 (1.86)	R-10.4 (1.83)	0.096 (0.55)
R-15 (2.64)	R-20.6 (3.62)	R-17.8 (3.13)	0.056 (0.32)
R-25 (4.40)	R-30.6 (5.38)	R-23.7 (4.17)	0.042 (0.24)

Base Assembly – Roof

Roof Exterior Insulation 1D R-Value (RSI)	R_r ft ² ·hr·°F / Btu (m ² K / W)	U_r Btu/ft ² ·hr ·°F (W/m ² K)
R-20 (3.52)	R-21.9 (3.86)	0.046 (0.26)

Parapet Linear Transmittance

Exterior Insulation 1D R-Value (RSI)	R ft ² ·hr·°F / Btu (m ² K / W)	U Btu/ft ² ·hr ·°F (W/m ² K)	ψ Btu/ft hr °F (W/m K)
R-5 (0.88)	10.0 (1.8)	0.100 (0.57)	0.238 (0.412)
R-15 (2.64)	12.2 (2.1)	0.082 (0.47)	0.180 (0.311)
R-25 (4.40)	13.1 (2.3)	0.076 (0.43)	0.236 (0.408)

Temperature Indices

	R5	R15	R25	
T_{i1}	0.57	0.66	0.68	Min T on exterior face of concrete block wall, at roof/gypsum intersection and air filled blocks
T_{i2}	0.78	0.81	0.82	Min T on interior surfaces, at ceiling/gypsum intersection, at studs
T_{i3}	0.01	0.01	0.01	Min T on concrete block parapet, at wood block and air filled concrete blocks

Detail 7.5.9

Precast Sandwich Panel – Steel Roof Deck with Open Web Steel Joist & Paraloc Thermally Broken Parapet Intersection

Thermal Performance Indicators

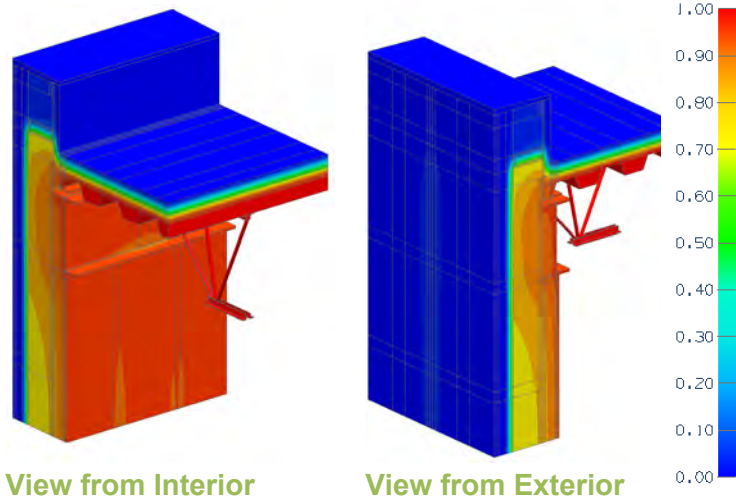

Assembly 1D (Nominal) R-Value	R_{1D}	R-3.1 (0.55 RSI) + sandwich panel insulation
Transmittance / Resistance without Anomaly	U_r, R_r, U_w, R_w	“clear field” U- and R-values: r = roof w = wall
Transmittance / Resistance	U_j, R_j, U_p, R_p	U- and R-values for: j = panel joint p = parapet
Linear Transmittance	Ψ_j, Ψ_p	Incremental increase in transmittance per linear length of anomaly

Nominal (1D) vs. Assembly Performance Indicators

Base Assembly – Wall

Sandwich Panel Insulation 1D R-value (RSI)	R_{1D} ft ² ·hr·°F / Btu (m ² K / W)	R_w ft ² ·hr·°F / Btu (m ² K / W)	U_w Btu/ft ² ·hr ·°F (W/m ² K)
R-10 (1.76)	R-13.1 (2.31)	R-12.8 (2.26)	0.078 (0.44)
R-15 (2.64)	R-18.1 (3.19)	R-17.7 (3.12)	0.056 (0.32)
R-20 (3.52)	R-23.1 (4.07)	R-22.6 (3.98)	0.044 (0.25)

Base Assembly – Roof

Roof Exterior Insulation 1D R-value (RSI)	R_r ft ² ·hr·°F / Btu (m ² K / W)	U_r Btu/ft ² ·hr ·°F (W/m ² K)
R-20 (3.52)	R-21.5 (3.79)	0.046 (0.26)

Panel Joint Linear Transmittance

Sandwich Panel Insulation 1D R-value (RSI)	R_j ft ² ·hr·°F / Btu (m ² K / W)	U_j Btu/ft ² ·hr ·°F (W/m ² K)	Ψ_j Btu/ft ·hr ·°F (W/m K)
R-10 (1.76)	R-9.3 (1.65)	0.107 (0.61)	0.099 (0.17)
R-15 (2.64)	R-12.0 (2.11)	0.084 (0.47)	0.092 (0.16)
R-20 (3.52)	R-14.5 (2.56)	0.069 (0.39)	0.084 (0.15)

Parapet Linear Transmittance

Sandwich Panel Insulation 1D R-value (RSI)	R_p ft ² ·hr·°F / Btu (m ² K / W)	U_p Btu/ft ² ·hr ·°F (W/m ² K)	Ψ_p Btu/ft ·hr ·°F (W/m K)
R-10 (1.76)	R-9.1 (1.60)	0.110 (0.63)	0.184 (0.319)
R-15 (2.64)	R-11.1 (1.96)	0.090 (0.51)	0.145 (0.250)
R-20 (3.52)	R-13.0 (2.28)	0.077 (0.44)	0.120 (0.208)

Detail 7.5.10

Highly Insulated Precast Concrete Sandwich Panel Wall Assembly – Roof to Wall Intersection with Wood-Framed Parapet

Thermal Performance Indicators

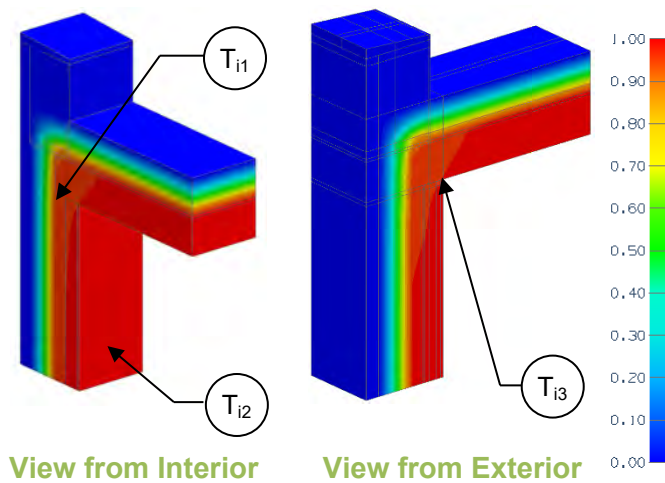

Assembly 1D (Nominal) R-Value	R_{1D}	R-2.76 (0.49 RSI) + insulation
Transmittance / Resistance without Anomaly	U_w, R_w, U_r, R_r	“clear field” U- and R-value w = wall r = roof
Transmittance / Resistance	U, R	U- and R-values for the overall assembly
Surface Temperature Index ¹	T_i	0 = exterior temperature 1 = interior temperature
Linear Transmittance	Ψ	Incremental increase in transmittance per length of parapet

¹Assumptions and limitations for surface temperatures identified in ASHRAE 1365-RP

Nominal (1D) vs. Assembly Performance Indicators

Base Assembly – Wall

Wall Insulation R-Value/in	Wall Insulation 1D R-Value (RSI)	R_{1D} ft ² ·hr·°F / Btu (m ² K / W)	R_w ft ² ·hr·°F / Btu (m ² K / W)	U_w Btu/ft ² ·hr ·°F (W/m ² K)
5	R-40 (7.04)	R-42.8 (7.53)	R-42.3 (7.45)	0.024 (0.134)
6	R-48 (8.45)	R-50.8 (8.94)	R-50.3 (8.86)	0.020 (0.113)
7	R-56 (9.86)	R-58.8 (10.35)	R-58.3 (10.27)	0.017 (0.097)

Base Assembly – Roof

Roof Insulation 1D R-Value (RSI)	R_{1D} ft ² ·hr·°F / Btu (m ² K / W)	R_w ft ² ·hr·°F / Btu (m ² K / W)	U_w Btu/ft ² ·hr ·°F (W/m ² K)
R-48 (8.45)	R-50.0 (8.81)	R-50.0 (8.81)	0.020 (0.114)

Parapet Linear Transmittance

Wall Insulation R-Value/in	Wall Insulation 1D R-Value (RSI)	R ft ² ·hr·°F / Btu (m ² K / W)	U Btu/ft ² ·hr ·°F (W/m ² K)	Ψ Btu/ft·hr·°F (W/mK)
5	R-42.8 (7.53)	R-47.2 (8.32)	0.021 (0.120)	-0.0066 (-0.0115)
6	R-50.8 (8.94)	R-50.4 (8.87)	0.020 (0.113)	-0.0008 (-0.0014)
7	R-58.8 (10.35)	R-52.9 (9.33)	0.019 (0.107)	0.0034 (0.0059)

*Clear Wall and Roof areas measured to the outside of the insulation

Temperature Indices

	R42.8	R50.8	R58.8	
T_{i1}	0.93	0.93	0.93	Min T on interior concrete precast sandwich panel surface, at concrete roof slab intersection
T_{i2}	0.95	0.96	0.96	Max T on interior concrete precast sandwich panel surface, between studs
T_{i3}	0.95	0.95	0.95	Min T on concrete ceiling, at drywall intersection, exposed to interior air

Detail 7.5.11

Owens Corning Exterior Insulated Concrete Block Wall Assembly with Heckmann Pos-I-Tie Vener Anchoring System Supporting Brick Veneer – Roof to Wall Intersection with Uninsulated Parapet

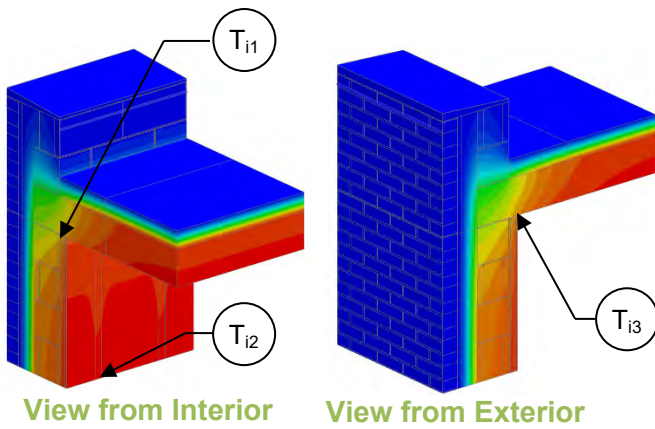

Thermal Performance Indicators

Assembly 1D (Nominal) R-Value	R_{1D}	R-5.6 (0.99 RSI) + exterior insulation
Transmittance / Resistance without Anomaly	U_r , R_r , U_w , R_w	“clear field” U- and R-values for: r = roof w = wall
Transmittance / Resistance	U, R	U- and R-values for overall assembly
Surface Temperature Index ¹	T_i	0 = exterior temperature 1 = interior temperature
Linear Transmittance	ψ	Incremental increase in per length of parapet

¹Assumptions and limitations for surface temperatures identified in ASHRAE 1365-RP

Nominal (1D) vs. Assembly Performance Indicators

Base Assembly – Wall

Exterior Insulation 1D R-Value (RSI)	R_{1Dw} ft ² ·hr·°F / Btu (m ² K / W)	R_w ft ² ·hr·°F / Btu (m ² K / W)	U_w Btu/ft ² ·hr ·°F (W/m ² K)
R-10.0 (1.76)	R-15.6 (2.75)	R-13.4 (2.36)	0.075 (0.42)
R-20.0 (3.52)	R-25.6 (4.51)	R-20.0 (3.52)	0.050 (0.28)

Base Assembly - Roof

Roof Insulation 1DR-Value (RSI)	R_r ft ² hr °F / Btu (m ² K / W)	U_r Btu/ft ² ·hr ·°F (W/m ² K)
R-20 (3.52)	R-21.9 (3.86)	0.046 (0.26)

Parapet Linear Transmittance

Exterior Insulation 1D R-Value (RSI)	R ft ² ·hr·°F / Btu (m ² K / W)	U Btu/ft ² ·hr ·°F (W/m ² K)	ψ Btu/ft hr °F (W/m K)
R-10.0 (1.76)	R-8.9 (1.56)	0.113 (0.64)	0.292 (0.505)
R-20.0 (3.52)	R-10.0 (1.75)	0.100 (0.57)	0.290 (0.502)

Temperature Indices

	R10	R20	
T_{i1}	0.72	0.74	Min T on interior CMU surface, at concrete roof slab intersection
T_{i2}	0.85	0.89	Max T on interior CMU surface, at studs and away from concrete roof slab intersection
T_{i3}	0.78	0.79	Min T on concrete ceiling, at drywall intersection, exposed to interior air

Detail 7.5.12

Owens Corning Exterior Insulated Concrete Block Wall Assembly with Heckmann Pos-I-Tie Vener Anchoring System Supporting Brick Veneer – Roof to Wall Intersection with Insulation Wrapped Around Parapet

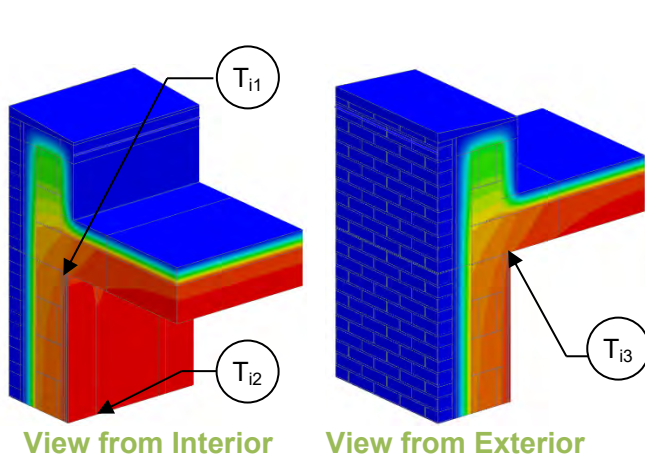

Thermal Performance Indicators

Assembly 1D (Nominal) R-Value	R_{1D}	R-5.6 (0.99 RSI) + exterior insulation
Transmittance / Resistance without Anomaly	U_r, R_r, U_w, R_w	“clear field” U- and R-values for: r = roof w = wall
Transmittance / Resistance	U, R	U- and R-values for overall assembly
Surface Temperature Index ¹	T_i	0 = exterior temperature 1 = interior temperature
Linear Transmittance	ψ	Incremental increase in transmittance per length of parapet

¹Assumptions and limitations for surface temperatures identified in ASHRAE 1365-RP

Nominal (1D) vs. Assembly Performance Indicators

Base Assembly – Wall

Exterior Insulation 1D R-Value (RSI)	R_{1Dw} ft ² ·hr·°F / Btu (m ² K / W)	R_w ft ² ·hr·°F / Btu (m ² K / W)	U_w Btu/ft ² ·hr ·°F (W/m ² K)
R-10.0 (1.76)	R-15.6 (2.75)	R-13.4 (2.36)	0.075 (0.42)
R-20.0 (3.52)	R-25.6 (4.51)	R-20.0 (3.52)	0.050 (0.28)

Base Assembly - Roof

Roof Insulation 1DR-Value (RSI)	R_r ft ² hr °F / Btu (m ² K / W)	U_r Btu/ft ² ·hr ·°F (W/m ² K)
R-20 (3.52)	R-21.9 (3.86)	0.046 (0.26)

Parapet Linear Transmittance

Exterior Insulation 1D R-Value (RSI)	R ft ² ·hr·°F / Btu (m ² K / W)	U Btu/ft ² ·hr ·°F (W/m ² K)	ψ Btu/ft hr °F (W/m K)
R-10.0 (1.76)	R-11.5 (2.03)	0.087 (0.49)	0.150 (0.260)
R-20.0 (3.52)	R-14.4 (2.53)	0.070 (0.40)	0.121 (0.209)

Temperature Indices

	R10	R20	
T_{i1}	0.81	0.85	Min T on interior CMU surface, at concrete roof slab intersection
T_{i2}	0.86	0.90	Max T on interior CMU surface, at studs and away from concrete roof slab intersection
T_{i3}	0.85	0.88	Min T on concrete ceiling, at drywall intersection, exposed to interior air

Detail 7.5.13

Window Wall System – Double Glazed Insulated Frame at Concrete Precast Panel Parapet & Roof Intersection

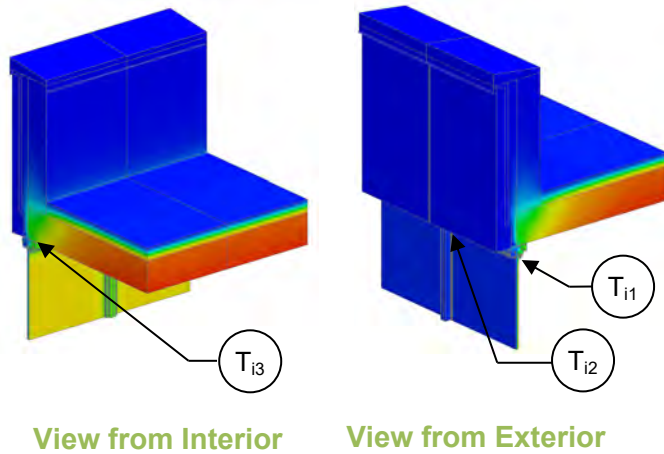

Thermal Performance Indicators

Transmittance / Resistance without Anomaly	U_r , R_r , U_w , R_w	“clear field” U- and R-values for: r = roof w = wall
Transmittance / Resistance	U , R	U- and R-values for overall assembly
Surface Temperature Index ¹	T_i	0 = exterior temperature 1 = interior temperature
Linear Transmittance	ψ	Incremental increase in transmittance per length of parapet

¹Assumptions and limitations for surface temperatures identified in ASHRAE 1365-RP

Nominal (1D) vs. Assembly Performance Indicators

Base Assembly – Roof

Roof Insulation 1DR-Value (RSI)	R_r ft ² ·hr·°F / Btu (m ² K / W)	U_r Btu/ft ² ·hr·°F (W/m ² K)
R-20.0 (3.52)	R-21.9 (3.86)	0.046 (0.26)
R-40.0 (7.04)	R-41.9 (7.38)	0.024 (0.14)

Base Assembly – Glazing

$U_{\text{centre of glass}}$ Btu/ft ² ·hr·°F (W/m ² K)	U_g Btu/ft ² ·hr·°F (W/m ² K)
0.321 (1.82)	0.408 (2.32)

Parapet Linear Transmittance

Parapet Insulation 1D R-Value (RSI)	R-20 Roof Insulation			R-40 Roof Insulation		
	R ft ² ·hr·°F / Btu (m ² K / W)	U Btu/ft ² ·hr·°F (W/m ² K)	ψ Btu/ft hr °F (W/m K)	R ft ² ·hr·°F / Btu (m ² K / W)	U Btu/ft ² ·hr·°F (W/m ² K)	ψ Btu/ft hr °F (W/m K)
R-10.0 (1.76)	R-4.1 (0.72)	0.245 (1.39)	0.354 (0.613)	R-4.4 (0.77)	0.228 (1.30)	0.336 (0.582)
R-15.0 (2.64)	R-4.1 (0.72)	0.244 (1.39)	0.351 (0.608)	R-4.4 (0.77)	0.227 (1.29)	0.332 (0.575)
R-20.0 (3.52)	R-4.1 (0.72)	0.244 (1.39)	0.351 (0.607)	R-4.4 (0.78)	0.227 (1.29)	0.331 (0.572)

Temperature Indices

	R-20 Roof Insulation			R-40 Roof Insulation			
	R10.0	R15.0	R20.0	R10.0	R15.0	R20.0	
T_{i1}	0.49	0.49	0.49	0.50	0.50	0.50	Min T on frame, along head at edge of glazing
T_{i2}	0.61	0.61	0.61	0.61	0.61	0.61	Min T on glazing, at corner of glazing
T_{i3}	0.54	0.54	0.54	0.56	0.56	0.56	Min T on slab, along head of window wall close to centre mullion

Detail 7.5.14

Window Wall System – Double Glazed Insulated Frame at Isokorb AXTI Thermally Broken Concrete Parapet & Roof Intersection

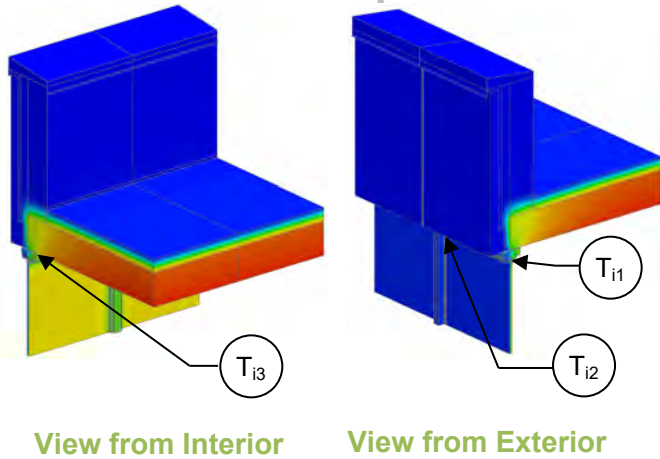

Thermal Performance Indicators

Transmittance / Resistance without Anomaly	U_r , R_r , U_w , R_w	“clear field” U- and R-values for: r = roof w = wall
Transmittance / Resistance	U , R	U- and R-values for overall assembly
Surface Temperature Index ¹	T_i	0 = exterior temperature 1 = interior temperature
Linear Transmittance	ψ	Incremental increase in transmittance per length of parapet

¹Assumptions and limitations for surface temperatures identified in ASHRAE 1365-RP

Nominal (1D) vs. Assembly Performance Indicators

Base Assembly – Roof

Roof Insulation 1DR-Value (RSI)	R_r ft ² hr °F / Btu (m ² K / W)	U_r Btu/ft ² ·hr ·°F (W/m ² K)
R-20.0 (3.52)	R-21.9 (3.86)	0.046 (0.26)
R-40.0 (7.04)	R-41.9 (7.38)	0.024 (0.14)

Base Assembly – Glazing

$U_{\text{centre of glass}}$ Btu/ft ² ·hr ·°F (W/m ² K)	U_g Btu/ft ² ·hr ·°F (W/m ² K)
0.321 (1.82)	0.408 (2.32)

Parapet Linear Transmittance

Parapet Insulation 1D R-Value (RSI)	R-20 Roof Insulation			R-40 Roof Insulation		
	R ft ² ·hr·°F / Btu (m ² K / W)	U Btu/ft ² ·hr ·°F (W/m ² K)	ψ Btu/ft hr °F (W/m K)	R ft ² ·hr·°F / Btu (m ² K / W)	U Btu/ft ² ·hr ·°F (W/m ² K)	ψ Btu/ft hr °F (W/m K)
R-10.0 (1.76)	R-4.7 (0.83)	0.211 (1.20)	0.160 (0.277)	R-5.0 (0.88)	0.201 (1.14)	0.176 (0.305)
R-15.0 (2.64)	R-4.7 (0.84)	0.211 (1.20)	0.156 (0.270)	R-5.0 (0.88)	0.200 (1.13)	0.170 (0.294)
R-20.0 (3.52)	R-4.8 (0.84)	0.211 (1.20)	0.154 (0.267)	R-5.0 (0.88)	0.199 (1.13)	0.168 (0.292)

Temperature Indices

	R-20 Roof Insulation			R-40 Roof Insulation			
	R10.0	R15.0	R20.0	R10.0	R15.0	R20.0	
T_{i1}	0.53	0.53	0.53	0.53	0.53	0.53	Min T on frame, along head at edge of glazing
T_{i2}	0.62	0.62	0.62	0.62	0.62	0.62	Min T on glazing, at corner of glazing
T_{i3}	0.61	0.61	0.61	0.61	0.62	0.62	Min T on slab, along head of window wall close to centre mullion

Detail 7.5.15

Window Wall System – Triple Glazed Insulated Frame at Concrete Precast Panel Parapet & Roof Intersection

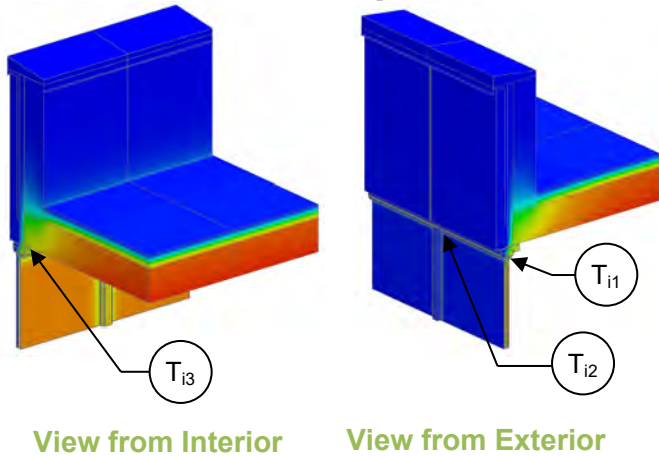

Thermal Performance Indicators

Transmittance / Resistance without Anomaly	U_r , R_r , U_w , R_w	“clear field” U- and R-values for: r = roof w = wall
Transmittance / Resistance	U , R	U- and R-values for overall assembly
Surface Temperature Index ¹	T_i	0 = exterior temperature 1 = interior temperature
Linear Transmittance	ψ	Incremental increase in transmittance per length of parapet

¹Assumptions and limitations for surface temperatures identified in ASHRAE 1365-RP

Nominal (1D) vs. Assembly Performance Indicators

Base Assembly – Roof

Roof Insulation 1DR-Value (RSI)	R_r ft ² ·hr·°F / Btu (m ² K / W)	U_r Btu/ft ² ·hr·°F (W/m ² K)
R-20.0 (3.52)	R-21.9 (3.86)	0.046 (0.26)
R-40.0 (7.04)	R-41.9 (7.38)	0.024 (0.14)

Base Assembly – Glazing

$U_{\text{centre of glass}}$ Btu/ft ² ·hr·°F (W/m ² K)	U_g Btu/ft ² ·hr·°F (W/m ² K)
0.143 (0.81)	0.250 (1.42)

Parapet Linear Transmittance

Parapet Insulation 1D R-Value (RSI)	R-20 Roof Insulation			R-40 Roof Insulation		
	R ft ² ·hr·°F / Btu (m ² K / W)	U Btu/ft ² ·hr·°F (W/m ² K)	ψ Btu/ft hr °F (W/m K)	R ft ² ·hr·°F / Btu (m ² K / W)	U Btu/ft ² ·hr·°F (W/m ² K)	ψ Btu/ft hr °F (W/m K)
R-10.0 (1.76)	R-5.3 (0.94)	0.188 (1.06)	0.374 (0.647)	R-5.9 (1.04)	0.169 (0.96)	0.344 (0.595)
R-15.0 (2.64)	R-5.3 (0.94)	0.187 (1.06)	0.371 (0.642)	R-5.9 (1.04)	0.169 (0.96)	0.342 (0.591)
R-20.0 (3.52)	R-5.4 (0.94)	0.187 (1.06)	0.369 (0.639)	R-6.0 (1.05)	0.168 (0.95)	0.338 (0.585)

Temperature Indices

	R-20 Roof Insulation			R-40 Roof Insulation			
	R10.0	R15.0	R20.0	R10.0	R15.0	R20.0	
T_{i1}	0.64	0.64	0.64	0.65	0.65	0.65	Min T on frame, along head at edge of glazing
T_{i2}	0.67	0.67	0.67	0.67	0.67	0.67	Min T on glazing, at corner of glazing
T_{i3}	0.65	0.65	0.65	0.67	0.67	0.66	Min T on slab, along head of window wall close to centre mullion

Detail 7.5.16

Window Wall System – Triple Glazed Insulated Frame at Isokorb AXTI Thermally Broken Concrete Parapet & Roof Intersection

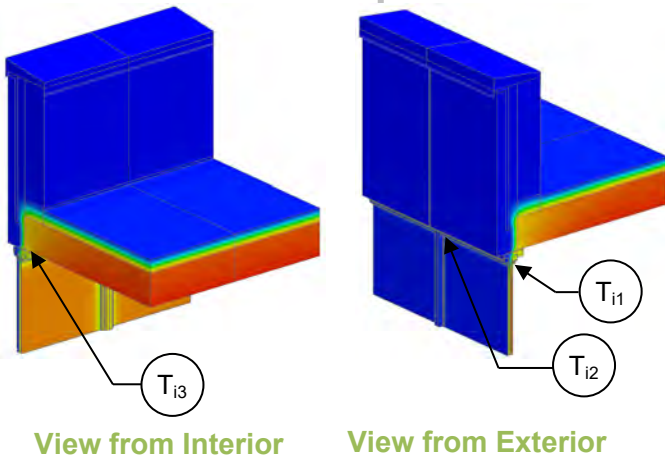

Thermal Performance Indicators

Transmittance / Resistance without Anomaly	U_r , R_r , U_w , R_w	“clear field” U- and R-values for: r = roof w = wall
Transmittance / Resistance	U , R	U- and R-values for overall assembly
Surface Temperature Index ¹	T_i	0 = exterior temperature 1 = interior temperature
Linear Transmittance	ψ	Incremental increase in transmittance per length of parapet

¹Assumptions and limitations for surface temperatures identified in ASHRAE 1365-RP

Nominal (1D) vs. Assembly Performance Indicators

Base Assembly – Roof

Roof Insulation 1DR-Value (RSI)	R_r ft ² ·hr·°F / Btu (m ² K / W)	U_r Btu/ft ² ·hr·°F (W/m ² K)
R-20.0 (3.52)	R-21.9 (3.86)	0.046 (0.26)
R-40.0 (7.04)	R-41.9 (7.38)	0.024 (0.14)

Base Assembly – Glazing

$U_{\text{centre of glass}}$ Btu/ft ² ·hr·°F (W/m ² K)	U_g Btu/ft ² ·hr·°F (W/m ² K)
0.143 (0.81)	0.250 (1.42)

Parapet Linear Transmittance

Parapet Insulation 1D R-Value (RSI)	R-20 Roof Insulation			R-40 Roof Insulation		
	R ft ² ·hr·°F / Btu (m ² K / W)	U Btu/ft ² ·hr·°F (W/m ² K)	ψ Btu/ft hr °F (W/m K)	R ft ² ·hr·°F / Btu (m ² K / W)	U Btu/ft ² ·hr·°F (W/m ² K)	ψ Btu/ft hr °F (W/m K)
R-10.0 (1.76)	R-6.9 (1.21)	0.145 (0.82)	0.126 (0.219)	R-7.5 (1.32)	0.134 (0.76)	0.138 (0.239)
R-15.0 (2.64)	R-6.9 (1.22)	0.145 (0.82)	0.122 (0.211)	R-7.5 (1.32)	0.133 (0.76)	0.134 (0.232)
R-20.0 (3.52)	R-7.0 (1.22)	0.144 (0.82)	0.118 (0.204)	R-7.6 (1.33)	0.132 (0.75)	0.130 (0.225)

Temperature Indices

	R-20 Roof Insulation			R-40 Roof Insulation			
	R10.0	R15.0	R20.0	R10.0	R15.0	R20.0	
T_{i1}	0.69	0.69	0.69	0.69	0.69	0.69	Min T on frame, along head at edge of glazing
T_{i2}	0.67	0.67	0.67	0.67	0.67	0.67	Min T on glazing, at corner of glazing
T_{i3}	0.73	0.73	0.74	0.74	0.74	0.74	Min T on slab, along head of window wall close to centre mullion

Detail 7.6.1

Exterior Insulated Concrete Drained EIFS Wall Assembly – Corner Intersection

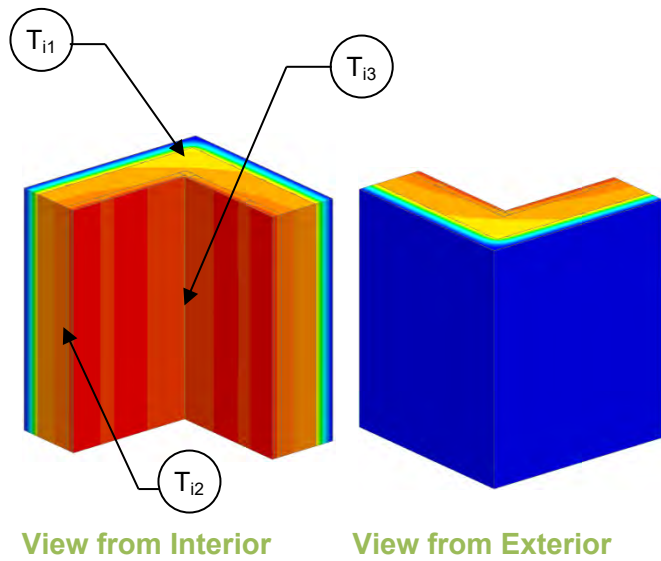

Thermal Performance Indicators

Assembly 1D (Nominal) R-Value	R_{1D}	R-3.0 (0.53 RSI) + exterior insulation
Transmittance / Resistance without Anomaly	U_o, R_o	"clear wall" U- and R-value, without corner
Transmittance / Resistance	U, R	U and R-values for the assembly
Surface Temperature Index ¹	T_i	0 = exterior temperature 1 = interior temperature
Linear Transmittance	ψ	Incremental increase in transmittance per linear length of corner

¹Assumptions and limitations for surface temperatures identified in ASHRAE 1365-RP

Nominal (1D) vs. Assembly Performance Indicators

Exterior Insulation 1D R-Value (RSI)	R_{1D} ft ² ·hr·°F / Btu (m ² K / W)	R_o ft ² ·hr·°F / Btu (m ² K / W)	U_o Btu/ft ² ·hr·°F (W/m ² K)	R ft ² ·hr·°F / Btu (m ² K / W)	U Btu/ft ² ·hr·°F (W/m ² K)	ψ Btu/ft hr °F (W/m K)
R-15 (2.64)	R-18.0 (3.17)	R-17.6 (3.10)	0.057 (0.32)	R-13.1 (2.30)	0.08 (0.43)	0.085 (0.147)

Temperature Indices

T_{i1}	0.81	Min T on concrete interior surface, at corner
T_{i2}	0.87	Max T on concrete interior surface, between studs away from corner
T_{i3}	0.89	Min T on drywall, at corner

Detail 7.6.2

Highly Insulated Precast Concrete Sandwich Panel Wall Assembly – Outside Corner

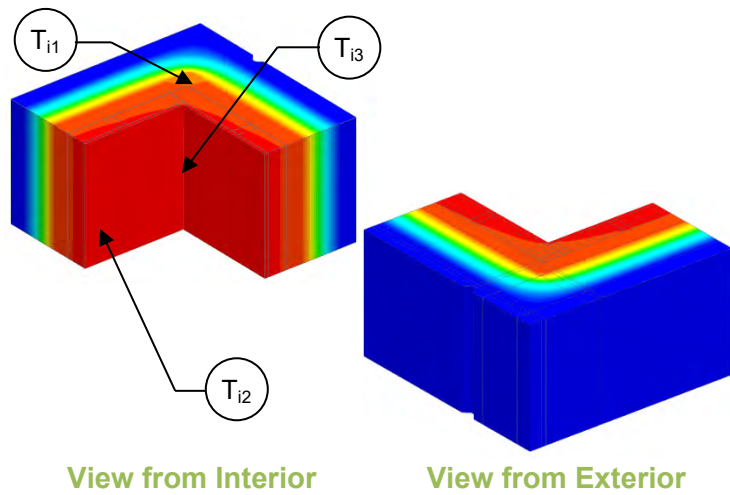

Thermal Performance Indicators

Assembly 1D (Nominal) R-Value	R_{1D}	R-2.76 (0.49 RSI) + insulation
Transmittance / Resistance without Anomaly	U_o, R_o	“clear field” U- and R-value
Transmittance / Resistance	U, R	U- and R-values for the overall assembly
Linear Transmittance	ψ	Incremental increase in transmittance for corners

Nominal (1D) vs. Assembly Performance Indicators

Base Assembly – Wall

Wall Insulation R-Value/in	Wall Insulation 1D R-Value (RSI)	R_{1D} ft ² ·hr·°F / Btu (m ² K / W)	R_o ft ² ·hr·°F / Btu (m ² K / W)	U_o Btu/ft ² ·hr·°F (W/m ² K)
5	R-40 (7.04)	R-42.8 (7.53)	R-42.3 (7.45)	0.024 (0.134)
6	R-48 (8.45)	R-50.8 (8.94)	R-50.3 (8.86)	0.020 (0.113)
7	R-56 (9.86)	R-58.8 (10.35)	R-58.3 (10.27)	0.017 (0.097)

Corner Linear Transmittance

Wall Insulation R-Value/in	Wall Insulation 1D R-Value (RSI)	R ft ² ·hr·°F / Btu (m ² K / W)	U Btu/ft ² ·hr·°F (W/m ² K)	ψ Btu/ft·hr·°F (W/mK)
5	R-42.8 (7.53)	R-52.6 (9.27)	0.019 (0.108)	-0.0272 (-0.0471)
6	R-50.8 (8.94)	R-62.0 (10.92)	0.016 (0.092)	-0.0221 (-0.0382)
7	R-58.8 (10.35)	R-71.4 (12.57)	0.014 (0.080)	-0.0184 (-0.0319)

*Clear Wall area measured to the outside of the insulation

Temperature Indices

	R42.8	R50.8	R58.8	
T_{i1}	0.90	0.92	0.93	Min T on interior concrete precast sandwich panel surface, at corner
T_{i2}	0.94	0.95	0.96	Max T on interior concrete precast sandwich panel surface, between studs away from corner
T_{i3}	0.96	0.96	0.97	Min T on drywall, at corner

Detail 7.7.1

Interior Insulated Concrete Mass Wall with 3 5/8" x 1 5/8" Steel Studs (16" o.c.) Supporting Interior Finish – Intermediate Floor Intersection above Parking Garage

Thermal Performance Indicators

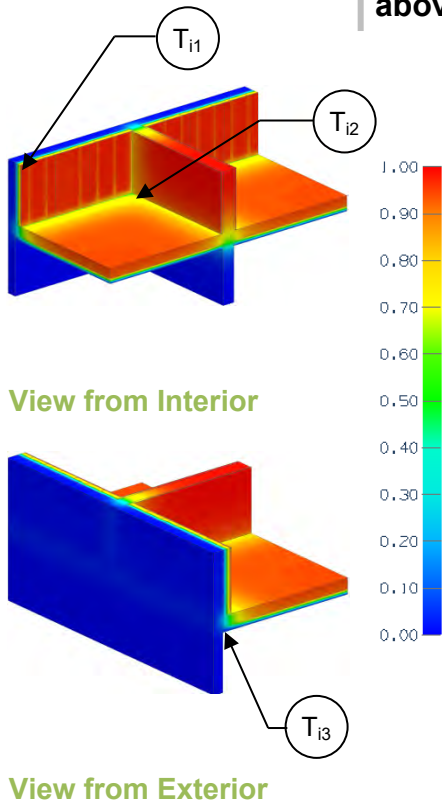

Assembly 1D (Nominal) R-Value	R_{1D}	R-14 (2.47 RSI) + interior wall insulation
Transmittance / Resistance without Anomaly	U_w, R_w, U_f, R_f	"clear wall" U- and R-value of: w = concrete wall and steel stud assembly f = floor
Transmittance / Resistance	$U_s, R_s, U_i, R_i, U_p, R_p$	U and R values for: s = concrete wall + slab i = concrete wall + interior wall p = interior wall + slab
Transmittance / Resistance	U, R	U and R-values for overall assembly
Surface Temperature Index ¹	T_i	0 = exterior temperature 1 = interior temperature
Linear Transmittance	ψ_i, ψ_s, ψ_p	Incremental increase in transmittance per linear length of i = interior wall at exterior wall s = slab at exterior wall p = interior wall at slab
Point Transmittance	χ	Incremental increase in transmittance for inner wall and slab intersection

¹Assumptions and limitations for surface temperatures identified in ASHRAE 1365-RP

Nominal (1D) vs. Assembly Performance Indicators

Base Assembly – Wall

Interior Insulation 1D R-Value (RSI)	R_{1D} ft ² ·hr·°F / Btu (m ² K / W)	R_w ft ² ·hr·°F / Btu (m ² K / W)	U_w Btu/ft ² ·hr·°F (W/m ² K)
R-10 (1.76)	R-24.0 (4.23)	R-19.8 (3.49)	0.050 (0.29)
R-15 (2.64)	R-29.0 (5.11)	R-24.9 (4.38)	0.040 (0.23)

Interior Wall Linear Transmittance at Exterior Wall

R_i ft ² ·hr·°F / Btu (m ² K / W)	U_i Btu/ft ² ·hr·°F (W/m ² K)	ψ_i Btu/ft·hr·°F (W/m K)
R-10.4 (1.83)	0.097 (0.55)	0.36 (0.622)
R-10.8 (1.90)	0.093 (0.53)	0.41 (0.710)

Base Assembly – Floor

Floor Insulation 1D R-Value (RSI)	R_f ft ² ·hr·°F / Btu (m ² K / W)	U_f Btu/ft ² ·hr·°F (W/m ² K)
R-20 (3.52)	R-22.2 (3.91)	0.045 (0.26)

Interior Wall Linear Transmittance at Slab

R_p ft ² ·hr·°F / Btu (m ² K / W)	U_p Btu/ft ² ·hr·°F (W/m ² K)	ψ_p Btu/ft·hr·°F (W/m K)
R-13.0 (2.28)	0.077 (0.44)	0.461 (0.799)

Slab Linear Transmittance at Exterior Wall

Exterior Insulation 1D R-Value (RSI)	R_s ft ² ·hr·°F / Btu (m ² K / W)	U_s Btu/ft ² ·hr·°F (W/m ² K)	ψ_s Btu/ft·hr·°F (W/m K)
R-10 (1.76)	R-11.1 (1.96)	0.090 (0.51)	0.406 (0.702)
R-15 (2.64)	R-12.0 (2.11)	0.084 (0.48)	0.390 (0.674)

Intersection Point Transmittance

R ft ² ·hr·°F / Btu (m ² K / W)	U Btu/ft ² ·hr·°F (W/m ² K)	χ^2 Btu/hr·°F (W/K)
R-10.0 (1.77)	0.100 (0.57)	-0.590 (-0.314)
R-10.5 (1.85)	0.095 (0.54)	-0.746 (-0.397)

²Values are negative for a correction factor. See section 6 in ASHRAE 1365-RP for clarification.

Temperature Indices

	R10	R15	
T_{i1}	0.04	0.03	Min T on concrete wall, between studs, away from wall and slab
T_{i2}	0.29	0.27	Max T on concrete wall, at corner intersection
T_{i3}	0.27	0.27	Min T on slab, at exterior wall away from intersection



Detail 7.7.2

Insulated Concrete Floor Slab – Concrete Column Intersection

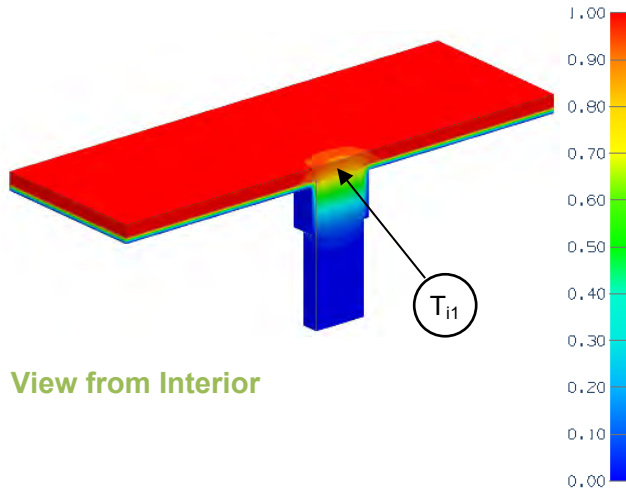

Thermal Performance Indicators

Assembly 1D (Nominal) R-Value	R_{1D}	R-2.2 (0.39 RSI) + Insulation
Transmittance / Resistance without Anomaly	U_o, R_o	"clear wall" U- and R-value, without pillar
Surface Temperature Index ¹	T_i	0 = exterior temperature 1 = interior temperature
Point Transmittance	χ	Incremental increase in transmittance for concrete column

¹Assumptions and limitations for surface temperatures identified in ASHRAE 1365-RP

Scenarios

Scenario	Insulation
A	Without insulation returning down column
B	With insulation returning down column 2.5 ft

Nominal (1D) vs. Assembly Performance Indicators

	Exterior Insulation 1D R-Value (RSI)	R_{1D} ft ² ·hr·°F / Btu (m ² K / W)	R_o ft ² ·hr·°F / Btu (m ² K / W)	U_o Btu/ft ² ·hr·°F (W/m ² K)	R ft ² ·hr·°F / Btu (m ² K / W)	U Btu/ft ² ·hr·°F (W/m ² K)	χ Btu/hr °F (W/K)
A	R-20.0 (3.52)	R-22.2 (3.92)	R-22.2 (3.92)	0.040 (0.23)	R-19.7 (3.47)	0.051 (0.29)	1.40 (0.74)
B	R-20.0 (3.52)	R-22.2 (3.92)	R-22.2 (3.92)	0.040 (0.23)	R-21.0 (3.71)	0.048 (0.27)	0.62 (0.33)

Temperature Indices

	A	B	
T_{i1}	0.62	0.79	Min T on concrete floor at column

Detail 7.7.3

Precast Sandwich Panel with 3 5/8" Steel Stud (16" o.c.) – Concrete Slab and Foundation Intersection

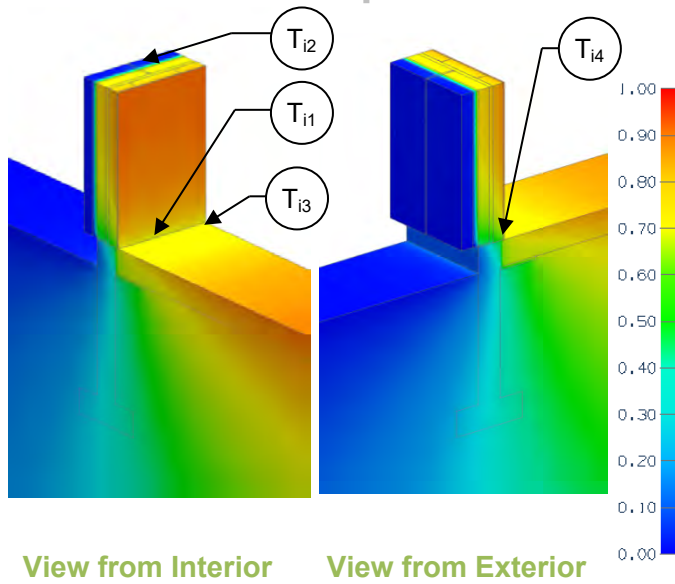

Thermal Performance Indicators

Assembly 1D (Nominal) R-Value	R_{1D}	R-3.9 (0.69 RSI) + sandwich panel insulation
Transmittance / Resistance without Anomaly	U_o, R_o	"clear wall" U- and R-value, without foundation
Transmittance / Resistance	U_j, R_j	U and R values with panel joint
Surface Temperature Index ¹	T_i	0 = exterior temperature 1 = interior temperature
Linear Transmittance	ψ_j, ψ_t	Incremental increase in transmittance per linear length of: j = panel joint t = assembly with foundation
Foundation Transmittance ²	L_{2Df}, L_{2Dt}	Heat loss of slab on grade per unit width of slab: f = floor t = assembly with foundation

¹Assumptions and limitations for surface temperatures identified in ASHRAE 1365-RP

²For on grade transition calculation, see Appendix B introduction

Nominal (1D) vs. Assembly Performance Indicators

Base Assembly – Wall

Sandwich Panel Insulation 1D R-Value (RSI)	R_{1D} ft ² ·hr·°F / Btu (m ² K / W)	R_o ft ² ·hr·°F / Btu (m ² K / W)	U_o Btu/ft ² ·hr·°F (W/m ² K)	R_j ft ² ·hr·°F / Btu (m ² K / W)	U_j Btu/ft ² ·hr·°F (W/m ² K)	ψ_j Btu/ft·hr·°F (W/m K)
R-10 (1.76)	R-13.9 (2.45)	R-12.6 (2.22)	0.079 (0.45)	R-11.7 (2.05)	0.086 (0.49)	0.026 (0.046)

Foundation Linear Transmittance

Foundation Insulation 1D R-Value (RSI)	Insulation Length in (mm)	L_{2Df} Btu/ft·hr·°F (W/m K)	L_{2Dt} Btu/ft·hr·°F (W/m K)	ψ_t Btu/ft·hr·°F (W/m K)
R-5 (0.88)	12 (305)	1.18 (2.04)	1.97 (3.41)	0.451 (0.781)
R-5 (0.88)	24 (610)	1.12 (1.94)	1.93 (3.34)	0.466 (0.807)
R-5 (0.88)	36 (914)	1.07 (1.86)	1.89 (3.27)	0.470 (0.814)
R-5 (0.88)	48 (1219)	1.04 (1.80)	1.86 (3.22)	0.474 (0.820)

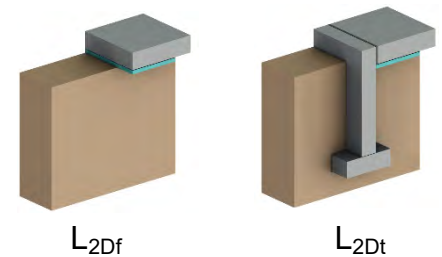

Temperature Indices

T_{i1}	0.41	Min T on sandwich panel, at slab intersection
T_{i2}	0.81	Max T on sandwich panel, at centre of panel away from vertical joint and slab
T_{i3}	0.16	Min T on slab, at sandwich panel intersection
T_{i4}	0.66	Min T on floor, at wall intersection

Detail 7.7.4

Precast Sandwich Panel with 3 5/8" Steel Stud (16" o.c.) - Concrete Slab and Foundation Wall Intersection

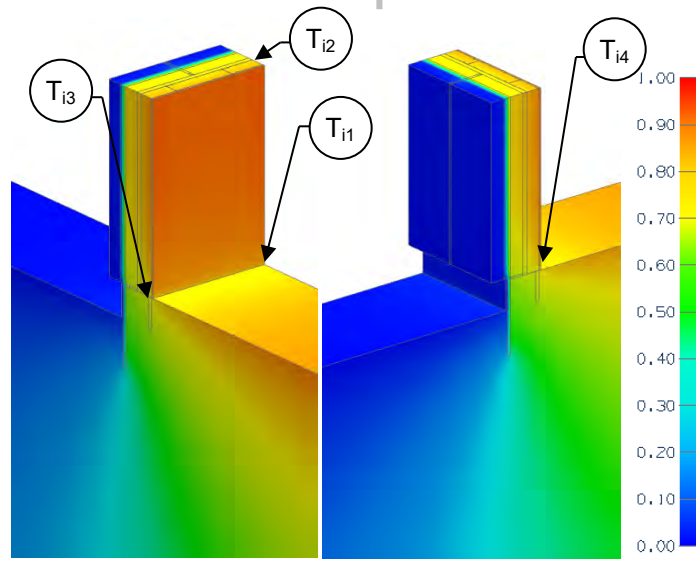

View from Interior

View from Exterior

Thermal Performance Indicators

Assembly 1D (Nominal) R-Value	R_{1D}	R-3.9 (0.69 RSI) + sandwich panel insulation
Transmittance / Resistance without Anomaly	U_o, R_o	"clear wall" U- and R-value, without foundation and panel joint
Transmittance / Resistance	U_j, R_j	U and R values with panel joint
Surface Temperature Index ¹	T_i	0 = exterior temperature 1 = interior temperature
Linear Transmittance	ψ_j, ψ_t	Incremental increase in transmittance per linear length of: j = panel joint t = assembly with foundation
Foundation Transmittance ²	L_{2Df}, L_{2Dt}	Heat loss of slab on grade per unit width of slab: f = floor t = assembly with foundation

¹Assumptions and limitations for surface temperatures identified in ASHRAE 1365-RP

²For on grade transition calculation, see Appendix B introduction

Nominal (1D) vs. Assembly Performance Indicators

Base Assembly – Wall

Sandwich Panel Insulation 1D R-Value (RSI)	R_{1D} ft ² ·hr·°F / Btu (m ² K / W)	R_o ft ² ·hr·°F / Btu (m ² K / W)	U_o Btu/ft ² ·hr ·°F (W/m ² K)	R_j ft ² ·hr·°F / Btu (m ² K / W)	U_j Btu/ft ² ·hr ·°F (W/m ² K)	ψ_j Btu/ft ·hr·°F (W/m K)
R-10 (1.76)	R-13.9 (2.45)	R-12.6 (2.22)	0.079 (0.45)	R-11.7 (2.05)	0.086 (0.49)	0.026 (0.046)

Foundation Linear Transmittance

Foundation Insulation 1D R-Value (RSI)	Insulation Depth in (mm)	L_{2Df} Btu/ft ·hr·°F (W/m K)	L_{2Dt} Btu/ft ·hr·°F (W/m K)	ψ_t Btu/ft ·hr·°F (W/m K)
R-5 (0.88)	12 (305)	1.19 (2.06)	1.71 (2.96)	0.175 (0.303)
R-5 (0.88)	24 (610)	1.10 (1.90)	1.63 (2.82)	0.188 (0.325)
R-5 (0.88)	36 (914)	1.04 (1.81)	1.58 (2.73)	0.190 (0.330)

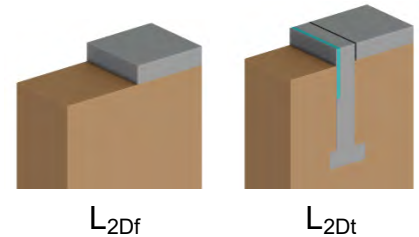

Temperature Indices

T_{i1}	0.71	Min T on sandwich panel, at slab intersection
T_{i2}	0.82	Max T on sandwich panel, at centre of panel away from vertical joint and slab
T_{i3}	0.68	Min T on slab, at sandwich panel intersection
T_{i4}	0.80	Min T on floor, at wall intersection

Detail 7.7.5

Precast Sandwich Panel with 3 5/8" Steel Stud (16" o.c.) – Thermally Broken Concrete Slab and Foundation Intersection

Thermal Performance Indicators

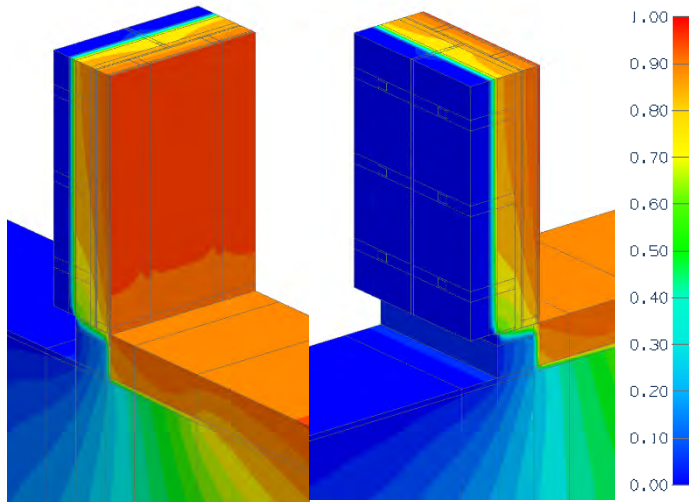

View from Interior

View from Exterior

Assembly 1D (Nominal) R-Value	R_{1D}	R-3.9 (0.69 RSI) + sandwich panel insulation
Transmittance / Resistance without Anomaly	U_o, R_o	"clear wall" U- and R-value, without foundation and panel joint
Transmittance / Resistance	U_j, R_j	U and R values for with panel joint
Surface Temperature Index ¹	T_i	0 = exterior temperature 1 = interior temperature
Foundation Transmittance ²	L_{2Df}, L_{2Dt}	Heat loss of slab on grade per unit width of slab: f = floor t = floor + wall + foundation
Linear Transmittance	ψ_j, ψ_t	Incremental increase in transmittance per linear length of: j = panel joint t = assembly with foundation

¹Assumptions and limitations for surface temperatures identified in ASHRAE 1365-RP

²Calculation method follows ISO 10211:2007, 10.4.3

Scenarios

Scenario	
1	Continuous Concrete Footing, Caulked Floor to Footing Joint
2	Continuous Concrete Footing, 1" Fibreboard Joint
3	2" Armatherm Block under Precast wall and Anchors Only, 1" Fibreboard Joint
4	2" Armatherm Block under Precast Wall, Anchors and Stud Wall, 1" Fibreboard Joint
5	2" Armatherm Block under Precast Wall, Anchors and Stud Wall, 2" Armatherm Joint

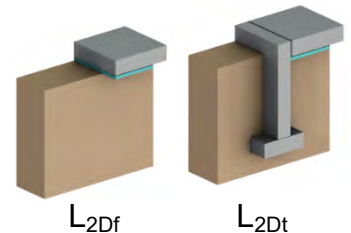

Nominal (1D) vs. Assembly Performance Indicators

Base Assembly – Wall

Sandwich Panel Insulation 1D R-Value (RSI)	R_{1D} ft ² ·hr·°F / Btu (m ² K / W)	R_o ft ² ·hr·°F / Btu (m ² K / W)	U_o Btu/ft ² ·hr ·°F (W/m ² K)	R_j ft ² ·hr·°F / Btu (m ² K / W)	U_j Btu/ft ² ·hr ·°F (W/m ² K)	ψ_j Btu/ft ·hr·°F (W/m K)
R-10 (1.76)	R-13.9 (2.45)	R-12.6 (2.22)	0.079 (0.45)	R-11.7 (2.05)	0.086 (0.49)	0.026 (0.046)

Foundation Linear Transmittance

Scenario	Foundation Insulation 1D R-Value (RSI)	Insulation Length From Footing in (mm)	L_{2Df} Btu/ft ·hr·°F (W/m K)	L_{2Dt} Btu/ft ·hr·°F (W/m K)	ψ_t Btu/ft ·hr·°F (W/m K)
1	R-5 (0.88)	12 (305)	1.18 (2.04)	1.97 (3.41)	0.451 (0.781)
2	R-5 (0.88)	12 (305)	1.18 (2.04)	1.88 (3.25)	0.360 (0.622)
3	R-5 (0.88)	12 (305)	1.18 (2.04)	1.83 (3.17)	0.313 (0.541)
4	R-5 (0.88)	12 (305)	1.18 (2.04)	1.74 (3.01)	0.221 (0.382)
5	R-5 (0.88)	12 (305)	1.18 (2.04)	1.71 (2.96)	0.190 (0.330)
	R-5 (0.88)	24 (610)	1.12 (1.94)	1.65 (2.85)	0.184 (0.319)
	R-5 (0.88)	36 (914)	1.07 (1.86)	1.60 (2.77)	0.183 (0.316)
	R-5 (0.88)	48 (1219)	1.04 (1.80)	1.57 (2.71)	0.182 (0.315)

Detail 7.7.6

Insulated Slab on Grade – Steel Column

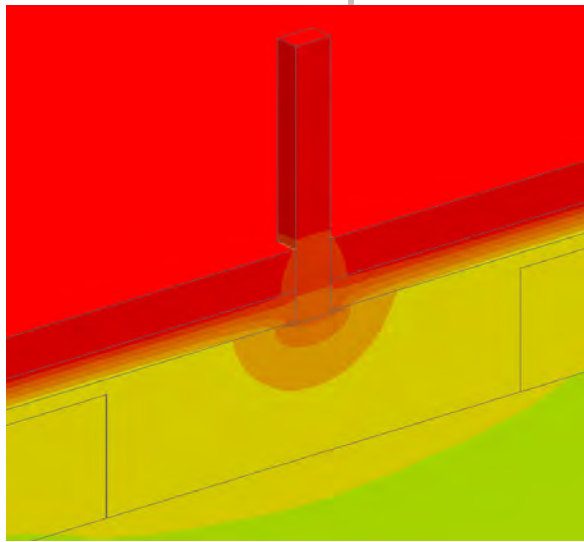

Thermal Performance Indicators

Assembly 1D (Nominal) R-Value	R_{1D}	R-1.7 (0.30 RSI) + insulation
Transmittance / Resistance without Anomaly	U_o, R_o	“clear field” U- and R-value, without column
Surface Temperature Index ¹	T_i	0 = exterior temperature 1 = interior temperature
Point Transmittance	χ	Incremental increase in transmittance for column and footing

¹Assumptions and limitations for surface temperatures identified in ASHRAE 1365-RP

View from Exterior

Nominal (1D) vs. Assembly Performance Indicators

Base Assembly – Floor

Slab Insulation 1D R-Value (RSI)	R_{1D} ft ² ·hr·°F / Btu (m ² K / W)	R_o ft ² ·hr·°F / Btu (m ² K / W)	U_o Btu/ft ² ·hr·°F (W/m ² K)
R-30 (5.26)	R-31.7 (5.57)	R-31.7 (5.57)	0.03 (0.179)

Column Point Transmittance

R ft ² ·hr·°F / Btu (m ² K / W)	U Btu/ft ² ·hr·°F (W/m ² K)	χ Btu/hr·°F (W/K)
R-29.9 (5.26)	0.03 (0.190)	1.64 (0.864)

Detail 7.7.7

Insulated Slab on Grade – Armatherm 500 Thermal Break under Column

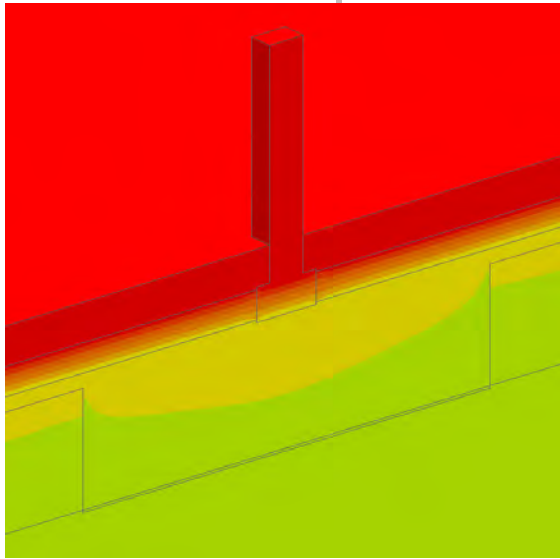

Thermal Performance Indicators

Assembly 1D (Nominal) R-Value	R_{1D}	R-1.7 (0.30 RSI) + insulation
Transmittance / Resistance without Anomaly	U_o, R_o	“clear field” U- and R-value, without column
Surface Temperature Index ¹	T_i	0 = exterior temperature 1 = interior temperature
Point Transmittance	χ	Incremental increase in transmittance for column and footing

¹Assumptions and limitations for surface temperatures identified in ASHRAE 1365-RP

View from Exterior

Nominal (1D) vs. Assembly Performance Indicators

Base Assembly – Floor

Slab Insulation 1D R-Value (RSI)	R_{1D} ft ² ·hr·°F / Btu (m ² K / W)	R_o ft ² ·hr·°F / Btu (m ² K / W)	U_o Btu/ft ² ·hr ·°F (W/m ² K)
R-30 (5.26)	R-31.7 (5.57)	R-31.7 (5.57)	0.03 (0.179)

Column Point Transmittance

R ft ² ·hr·°F / Btu (m ² K / W)	U Btu/ft ² ·hr ·°F (W/m ² K)	χ Btu/hr·°F (W/K)
R-31.5 (5.55)	0.03 (0.180)	0.151 (0.079)

Detail 7.7.8

Highly Insulated Precast Concrete Sandwich Panel Wall Assembly – Base of Wall at Foundation with Insulation Skirt

Thermal Performance Indicators

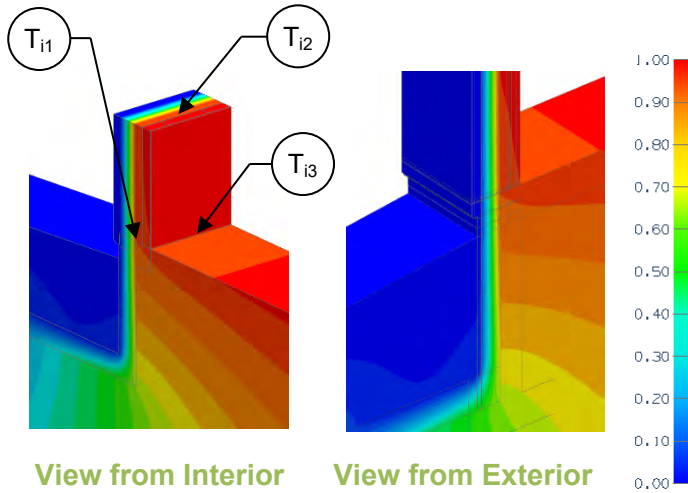

Assembly 1D (Nominal) R-Value	R_{1D}	R-2.76 (0.49 RSI) + insulation
Transmittance / Resistance without Anomaly	U_o, R_o	“clear field” U- and R-value
Transmittance / Resistance	U, R	U- and R-values for the overall assembly
Surface Temperature Index ¹	T_i	0 = exterior temperature 1 = interior temperature
Foundation Transmittance	L	Heat Loss of slab on grade per unit width of slab
Linear Transmittance	Ψ	Incremental increase in transmittance for base of wall detail at foundation

¹Assumptions and limitations for surface temperatures identified in ASHRAE 1365-RP

Nominal (1D) vs. Assembly Performance Indicators

Base Assembly – Wall

Wall Insulation R-Value/in	Wall Insulation 1D R-Value (RSI)	R_{1D} ft ² ·hr·°F / Btu (m ² K / W)	R_o ft ² ·hr·°F / Btu (m ² K / W)	U_o Btu/ft ² ·hr ·°F (W/m ² K)
5	R-40 (7.04)	R-42.8 (7.53)	R-42.3 (7.45)	0.024 (0.134)
6	R-48 (8.45)	R-50.8 (8.94)	R-50.3 (8.86)	0.020 (0.113)
7	R-56 (9.86)	R-58.8 (10.35)	R-58.3 (10.27)	0.017 (0.097)

Base Assembly – Foundation

Foundation Insulation R-Value/in	Foundation Insulation 1D R-Value (RSI)	L Btu/ft·hr·°F (W/mK)
6	R-48 (8.45)	0.64 (1.11)

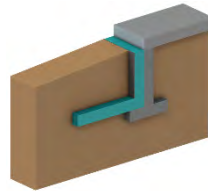

Base of Wall at Foundation Linear Transmittance

Wall Insulation R-Value/in	Wall Insulation 1D R-Value (RSI)	R ft ² ·hr·°F / Btu (m ² K / W)	U Btu/ft ² ·hr ·°F (W/m ² K)	Ψ Btu/ft·hr·°F (W/mK)
5	R-42.8 (7.53)	R-4.5 (0.80)	0.220 (1.251)	0.0030 (0.0053)
6	R-50.8 (8.94)	R-4.6 (0.81)	0.217 (1.230)	0.0033 (0.0057)
7	R-58.8 (10.35)	R-4.7 (0.82)	0.214 (1.216)	0.0041 (0.0070)

Temperature Indices

	R42.8	R50.8	R58.8	
T_{i1}	0.91	0.91	0.91	Min T on interior concrete precast sandwich panel surface, at slab intersection
T_{i2}	0.95	0.96	0.96	Max T on interior concrete precast sandwich panel surface, between studs and away from slab
T_{i3}	0.92	0.92	0.92	Min T on floor, at drywall intersection

Detail 7.7.9

Owens Corning Exterior Insulated Concrete Block Wall Assembly with Steel Shelf Angle and Heckmann Pos-I-Tie Vener Anchoring System Supporting Brick Veneer and Insulation Below Floor – Slab on Grade and Foundation Intersection

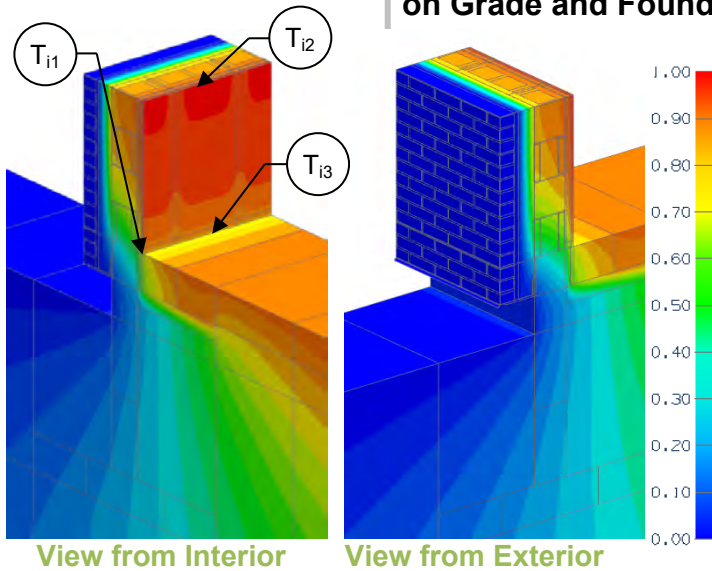

Thermal Performance Indicators

Assembly 1D (Nominal) R-Value	R_{1D}	R-5.6 (0.99 RSI) + exterior insulation
Transmittance / Resistance without Anomaly	U_o, R_o	“clear wall” U- and R-value without slab and shelf angle
Transmittance / Resistance	U, R	U- and R-values for overall assembly
Surface Temperature Index ¹	T_i	0 = exterior temperature 1 = interior temperature
Foundation Transmittance ²	L_{2Df}, L_{2Dt}	Heat loss of slab on grade per unit width of slab: f = floor t = floor + wall + foundation
Linear Transmittance	ψ	Incremental increase in transmittance per linear length of foundation

¹Assumptions and limitations for surface temperatures identified in ASHRAE 1365-RP

²Calculation method follows ISO 10211:2007, 10.4.3

Nominal (1D) vs. Assembly Performance Indicators

Base Assembly – Wall

Sandwich Panel Insulation 1D R-Value (RSI)	R_{1D} ft ² ·hr·°F / Btu (m ² K / W)	R_o ft ² ·hr·°F / Btu (m ² K / W)	U_o Btu/ft ² ·hr·°F (W/m ² K)
R-10.0 (1.76)	R-15.6 (2.75)	R-13.4 (2.36)	0.075 (0.42)
R-20.0 (3.52)	R-25.6 (4.51)	R-20.0 (3.52)	0.050 (0.28)

Foundation Linear Transmittance

Foundation Insulation 1D R-Value (RSI)	Insulation Length in (mm)	L_{2Df} Btu/ft·hr·°F (W/m K)	L_{2Dt} Btu/ft·hr·°F (W/m K)	ψ Btu/ft·hr·°F (W/m K)
R-17.5 (3.08)	24 (610)	1.25 (2.16)	1.75 (3.02)	0.301 (0.521)
R-17.5 (3.08)	24 (610)	1.25 (2.16)	1.70 (2.95)	0.322 (0.557)

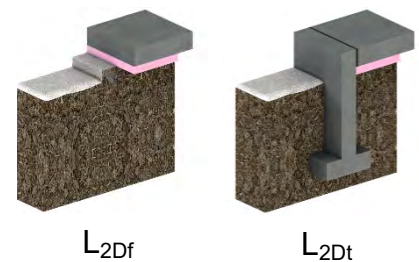

Temperature Indices

	R10	R20	
T_{i1}	0.55	0.56	Min T on interior CMU surface, at slab intersection
T_{i2}	0.82	0.86	Max T on interior CMU surface, between studs and away from slab
T_{i3}	0.69	0.70	Min T on floor, at drywall intersection

Detail 7.7.10

Owens Corning Exterior Insulated Concrete Block Wall Assembly with Stainless Steel Shelf Angle and Heckmann Pos-I-Tie Veneer Anchoring System Supporting Brick Veneer and Insulation Below Floor – Slab on Grade and Foundation Intersection

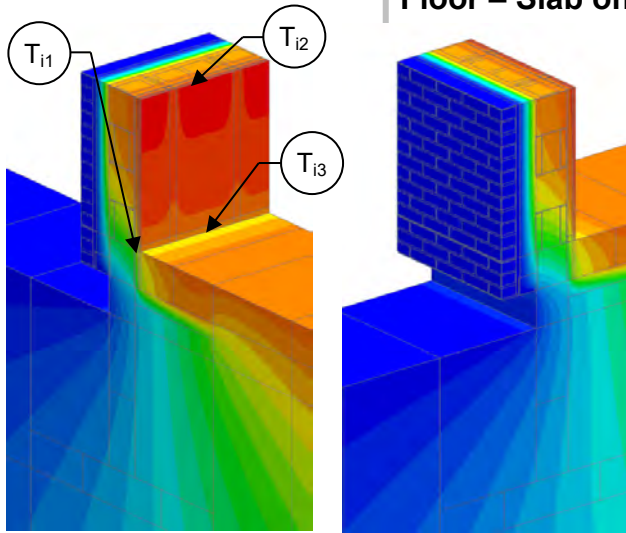

View from Interior

View from Exterior

Thermal Performance Indicators

1.00	Assembly 1D (Nominal) R-Value	R_{1D}	R-5.6 (0.99 RSI) + exterior insulation
0.90	Transmittance / Resistance without Anomaly	U_o, R_o	“clear wall” U- and R-value without slab and shelf angle
0.80	Transmittance / Resistance	U, R	U- and R-values for overall assembly
0.70	Surface Temperature Index ¹	T_i	0 = exterior temperature 1 = interior temperature
0.60	Foundation Transmittance ²	L_{2Df}, L_{2Dt}	Heat loss of slab on grade per unit width of slab: f = floor t = floor + wall + foundation
0.50	Linear Transmittance	ψ	Incremental increase in transmittance per linear length of foundation
0.40			
0.30			
0.20			
0.10			
0.00			

¹Assumptions and limitations for surface temperatures identified in ASHRAE 1365-RP

²Calculation method follows ISO 10211:2007, 10.4.3

Nominal (1D) vs. Assembly Performance Indicators

Base Assembly – Wall

Sandwich Panel Insulation 1D R-Value (RSI)	R_{1D} ft ² ·hr·°F / Btu (m ² K / W)	R_o ft ² ·hr·°F / Btu (m ² K / W)	U_o Btu/ft ² ·hr·°F (W/m ² K)
R-10.0 (1.76)	R-15.6 (2.75)	R-13.4 (2.36)	0.075 (0.42)
R-20.0 (3.52)	R-25.6 (4.51)	R-20.0 (3.52)	0.050 (0.28)

Foundation Linear Transmittance

Foundation Insulation 1D R-Value (RSI)	Insulation Length in (mm)	L_{2Df} Btu/ft·hr·°F (W/m K)	L_{2Dt} Btu/ft·hr·°F (W/m K)	ψ Btu/ft·hr·°F (W/m K)
R-17.5 (3.08)	24 (610)	1.25 (2.16)	1.68 (2.90)	0.230 (0.399)
R-17.5 (3.08)	24 (610)	1.25 (2.16)	1.62 (2.81)	0.241 (0.418)

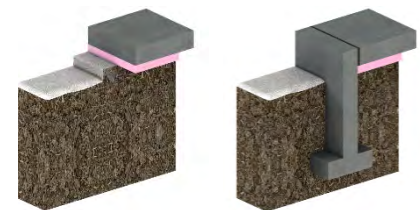

L_{2Df}

L_{2Dt}

Temperature Indices

	R10	R20	
T_{i1}	0.61	0.63	Min T on interior CMU surface, at slab intersection
T_{i2}	0.83	0.87	Max T on interior CMU surface, between studs and away from slab
T_{i3}	0.73	0.74	Min T on floor, at drywall intersection

Detail 7.8.1

Precast Sandwich Panel Wall Assembly – Emloc Thermally Broken Embedment Detail

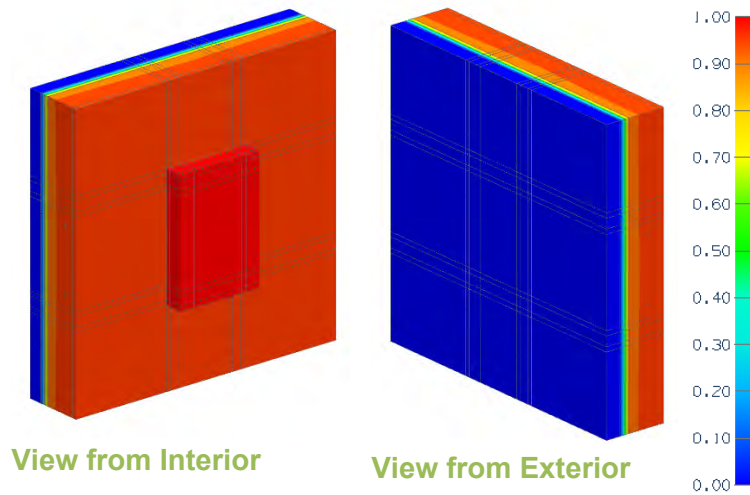

Thermal Performance Indicators

Assembly 1D (Nominal) R-Value	R_{1D}	R-1.8 (0.32 RSI) + sandwich panel insulation
Transmittance / Resistance without Anomaly	U_o, R_o	“clear field” U- and R-values, without embedment
Transmittance / Resistance	U, R	U- and R-values for the assembly
Surface Temperature Index ¹	T_i	0 = exterior temperature 1 = interior temperature
Point Transmittance	χ	Incremental increase in transmittance for embedment

¹Assumptions and limitations for surface temperatures identified in ASHRAE 1365-RP

Nominal (1D) vs. Assembly Performance Indicators

Base Assembly – Wall

Sandwich Panel Insulation 1D R-value (RSI)	R_{1Dw} ft ² ·hr·°F / Btu (m ² K / W)	R_o ft ² ·hr·°F / Btu (m ² K / W)	U_o Btu/ft ² ·hr ·°F (W/m ² K)
R-10 (1.76)	R-11.8 (2.08)	R-11.8 (2.06)	0.085 (0.48)
R-15 (2.64)	R-16.8 (2.96)	R-16.7 (2.94)	0.060 (0.34)
R-20 (3.52)	R-21.8 (3.84)	R-21.7 (3.82)	0.046 (0.26)

Embedment Point Transmittance

Sandwich Panel Insulation 1D R-value (RSI)	R ft ² ·hr·°F / Btu (m ² K / W)	U Btu/ft ² ·hr ·°F (W/m ² K)	χ Btu/ ·hr ·°F (W/K)
R-10 (1.76)	R-11.4 (2.00)	0.088 (0.50)	0.053 (0.028)
R-15 (2.64)	R-15.5 (2.73)	0.065 (0.367)	0.094 (0.050)
R-20 (3.52)	R-19.8 (3.48)	0.051 (0.287)	0.090 (0.048)

8.0 Wood-Frame and Timber Construction

Detail 8.1.1	B.8.1
Interior Insulated 2x4 Wood Stud Wall Assembly – Clear Wall	
Detail 8.1.2	B.8.2
Interior Insulated 2x6 Wood Stud Wall Assembly – Clear Wall	
Detail 8.1.3	B.8.3
Interior Insulated 2x6 Wood Stud (16” o.c.) Wall Assembly with Wood Strapping Supporting Fiber Cement Board and R-19 Batt Insulation in Stud Cavity - Clear Wall	
Detail 8.1.4	B.8.4
Exterior and Interior Insulated 2x6 Wood Stud (16” o.c.) Wall Assembly with Wood Strapping Supporting Fiber Cement Board and R-19 Batt Insulation in Stud Cavity – Clear Wall	
Detail 8.1.5	B.8.5
Exterior and Interior Insulated 2x6 Wood Stud (16” o.c.) Wall Assembly with Continuous Rigid Insulation Supporting Fiber Cement Board and R-19 Batt Insulation in Stud Cavity – Clear Wall	
Detail 8.1.6	B.8.6
Exterior and Interior Insulated 2x6 Wood Stud (16” o.c.) Wall Assembly with Horizontal Metal Z-Girts (24” o.c.) Supporting Fiber Cement Board and R-19 Batt Insulation in Stud Cavity – Clear Wall	
Detail 8.1.7	B.8.7
Exterior Insulated 2x6 Wood Stud (16” o.c.) Wall Assembly with Knight MFI-System (24” o.c.) Supporting Cladding – Clear Wall	
Detail 8.1.8	B.8.8
Exterior and Interior Insulated 2x6 Wood Stud (16” o.c.) Wall Assembly with Knight MFI-System (24” o.c.) Supporting Cladding and R-19 Batt Insulation in Stud Cavity – Clear Wall	
Detail 8.1.9	B.8.9
Exterior Insulated 2x6 Wood Stud (16”o.c.) Wall Assembly with Thermally Broken Aluminum Clip Rail System (24” o.c.) Supporting Cladding – Clear Wall	
Detail 8.1.10	B.8.10
Interior Insulated Double Framed Wall 2x6 and 2x4 Wood Stud (16” o.c.) Wall Assembly with 2” Gap – Clear Wall	
Detail 8.1.11	B.8.11
Interior Insulated Double Framed Wall 2x6 and 2x4 Wood Stud (16” o.c.) Wall Assembly with 3” Gap – Clear Wall	
Detail 8.1.12	B.8.12
Interior Insulated Double Framed Wall 2x6 and 2x4 Wood Stud (16” o.c.) Wall Assembly with 4” Gap – Clear Wall	
Detail 8.1.13	B.8.13

Interior Insulated Cross Laminated Timber (CLT) Spandrel with ISO-CONNECT
Anchor – Anchor Point Transmittance

- Detail 8.1.14****B.8.14**
Exterior and Interior Insulated 2"x6" Wood Stud (16" o.c. and 24" o.c.) Wall
Assembly with Heckmann Pos-I-Tie Veneer Anchoring System Supporting Brick
Veneer and Owens Corning R-19 Batt Insulation in Stud Cavity – Clear Wall
- Detail 8.1.15****B.8.15**
Exterior and Interior Insulated 2"x6" Wood Stud (16" o.c. and 24" o.c.) Wall
Assembly with Heckmann Pos-I-Tie Veneer Anchoring System Supporting Brick
Veneer and Owens Corning R-22 Batt Insulation in Stud Cavity – Clear Wall
- Detail 8.1.16****B.8.16**
Exterior and Interior Insulated 2"x6" Wood Stud (16" o.c. and 24" o.c.) Wall
Assembly with Heckmann Pos-I-Tie Veneer Anchoring System Supporting Brick
Veneer and Owens Corning R-24 Batt Insulation in Stud Cavity – Clear Wall
- Detail 8.1.17****B.8.17**
Exterior Insulated Cross Laminated Timber (CLT) Wall Assembly with
Continuous Rigid Insulation Supporting Fiber Cement Board – Clear Wall
- Detail 8.1.18****B.8.18**
Exterior Insulated Cross Laminated Timber (CLT) Wall Assembly with Wood
Strapping and Continuous Rigid Insulation Supporting Fiber Cement Board
- Detail 8.1.19****B.8.19**
Exterior and Interior Insulated 2x6 Wood Stud (16" o.c.) Wall Assembly with Brick
Ties Supporting Brick Veneer and R-19 Batt Insulation in Stud Cavity – Clear
Wall
- Detail 8.1.20****B.8.20**
Exterior Insulated 2x6 Wood Stud (16" o.c.) Wall with Interior OSB and Wood
Furring Assembly & Brick Ties Supporting Brick Veneer – Clear Wall
- Detail 8.1.21****B.8.21**
Exterior and Interior Insulated 2x6 Wood Stud (16" o.c.) Wall with Interior OSB
and Wood Furring Assembly & Brick Ties Supporting Brick Veneer – Clear Wall
- Detail 8.1.22****B.8.22**
Exterior Insulated 2x6 Wood Stud (16" o.c.) Wall with Interior Wood Furring
Assembly & Brick Ties Supporting Brick Veneer – Clear Wall
- Detail 8.1.23****B.8.23**
Exterior and Interior Insulated 2x6 Wood Stud (16" o.c.) Wall with Interior Wood
Furring Assembly & Brick Ties Supporting Brick Veneer – Clear Wall
- Detail 8.1.24****B.8.24**
Interior Insulated Double Framed Wall 2x6 and 2x4 Wood Stud (16" o.c.) Wall
Assembly with 1" Gap – Clear Wall
- Detail 8.1.25****B.8.25**

Exterior and Interior Insulated 2x6 Wood Stud (16" o.c.) Wall Assembly with SOPREMA SOPRA-XPS 20 and ACS-S Thermal Clip Supporting Metal Cladding with R-19 Cellulose Insulation in Stud Cavity - Clear Wall	
Detail 8.1.26	B.8.26
Exterior and Interior Insulated 2x6 Wood Stud (24" o.c.) Wall Assembly with SOPREMA SOPRA-XPS 20 and ACS-S Thermal Clip Supporting Metal Cladding with R-19 Cellulose Insulation in Stud Cavity - Clear Wall	
Detail 8.1.27	B.8.27
Exterior and Interior Insulated 2x6 Wood Stud (16" o.c.) Wall Assembly with SOPREMA SOPRA-SPF 202 and ACS-S Thermal Clip Supporting Metal Cladding with R-19 Cellulose Insulation in Stud Cavity - Clear Wall	
Detail 8.1.28	B.8.28
Exterior and Interior Insulated 2x6 Wood Stud (24" o.c.) Wall Assembly with SOPREMA SOPRA-SPF 202 and ACS-S Thermal Clip Supporting Metal Cladding with R-19 Cellulose Insulation in Stud Cavity - Clear Wall	
Detail 8.1.29	B.8.29
Exterior and Interior Insulated 2x6 Wood Stud (16" o.c.) Wall Assembly with SOPREMA SOPRA-ISO V PLUS and ACS-S Thermal Clip Supporting Metal Cladding with R-19 Cellulose Insulation in Stud Cavity - Clear Wall	
Detail 8.1.30	B.8.30
Exterior and Interior Insulated 2x6 Wood Stud (24" o.c.) Wall Assembly with SOPREMA SOPRA-ISO V PLUS and ACS-S Thermal Clip Supporting Metal Cladding with R-19 Cellulose Insulation in Stud Cavity - Clear Wall	
Detail 8.1.31	B.8.31
Exterior and Interior Insulated 2x6 Wood Stud (16" o.c.) Wall Assembly with Mineral Wool and ACS-S Thermal Clip Supporting Metal Cladding with R-19 Cellulose Insulation in Stud Cavity - Clear Wall	
Detail 8.1.32	B.8.32
Exterior and Interior Insulated 2x6 Wood Stud (24" o.c.) Wall Assembly with Mineral Wool and ACS-S Thermal Clip Supporting Metal Cladding with R-19 Cellulose Insulation in Stud Cavity - Clear Wall	
Detail 8.1.33	B.8.33
Exterior and Interior Insulated 2x6 Wood Stud (16" o.c.) Wall Assembly with Protected SOPREMA SOPRA-ISO V PLUS and ACS-S Thermal Clip Supporting Metal Cladding with R-19 Cellulose Insulation in Stud Cavity - Clear Wall	
Detail 8.1.34	B.8.34
Exterior and Interior Insulated 2x6 Wood Stud (24" o.c.) Wall Assembly with Protected SOPREMA SOPRA-ISO V PLUS and ACS-S Thermal Clip Supporting Metal Cladding with R-19 Cellulose Insulation in Stud Cavity - Clear Wall	
Detail 8.1.35	B.8.35

Exterior and Interior Insulated 2x4 Wood Stud (16" o.c.) Wall Assembly with Protected SOPREMA SOPRA-ISO V PLUS and ACS-S Thermal Clip Supporting Metal Cladding with R-13 Cellulose Insulation in Stud Cavity - Clear Wall	
Detail 8.1.36	B.8.36
Exterior and Interior Insulated 2x4 Wood Stud (24" o.c.) Wall Assembly with Protected SOPREMA SOPRA-ISO V PLUS and ACS-S Thermal Clip Supporting Metal Cladding with R-13 Cellulose Insulation in Stud Cavity - Clear Wall	
Detail 8.1.37	B.8.37
Exterior and Interior Insulated 2x6 Wood Stud (8" o.c.) Wall Assembly with Wood Strapping and Continuous Insulation Supporting Rainscreen Fiber Cement Board and R-19 Batt Insulation in Stud Cavity – Clear Wall	
Detail 8.2.1	B.8.38
Exterior and Interior Insulated 2x6 Wood Stud (16" o.c.) Wall Assembly with Wood Strapping Supporting Fiber Cement Board and R-19 Batt Insulation in Stud Cavity - Rim Joist and Floor Intersection with Metal Flashing Bypassing Exterior Insulation	
Detail 8.2.2	B.8.39
Exterior and Interior Insulated 2x6 Wood Stud (16" o.c.) Wall Assembly with Wood Strapping Supporting Fiber Cement Board and R-19 Batt Insulation in Stud Cavity - Rim Joist and Floor Intersection without Metal Flashing Bypassing Exterior Insulation	
Detail 8.2.3	B.8.40
Exterior and Interior Insulated 2x6 Wood Stud (16" o.c.) Wall Assembly with Wood Strapping Supporting Fiber Cement Board and R-19 Batt Insulation in Stud Cavity – Cantilevered Wood Joist Balcony Intersection	
Detail 8.2.4	B.8.41
Exterior and Interior Insulated 2x6 Wood Stud (16" o.c.) Wall Assembly with Wood Strapping Supporting Fiber Cement Board and R-19 Batt Insulation in Stud Cavity – Independently Supported Balcony Intersection	
Detail 8.2.5	B.8.42
Exterior and Interior Insulated 2x6 Wood Stud (16" o.c.) Wall Assembly with Wood Strapping and Continuous Insulation Supporting Fiber Cement Board and R-19 Batt Insulation in Stud Cavity – Cantilevered Floor Intersection	
Detail 8.2.6	B.8.43
Interior Insulated Double Framed Wall 2x6 and 2x4 Wood Stud (16" o.c.) Wall Assembly with 2" Gap – Rim Joist and Floor Intersection	
Detail 8.2.7	B.8.44
Interior Insulated Double Framed Wall 2x6 and 2x4 Wood Stud (16" o.c.) Wall Assembly with 3" Gap – Rim Joist and Floor Intersection	
Detail 8.2.8	B.8.45

	Interior Insulated Double Framed Wall 2x6 and 2x4 Wood Stud (16" o.c.) Wall Assembly with 4" Gap – Rim Joist and Floor Intersection	
Detail 8.2.9	B.8.46
	Interior Insulated Double Framed Wall 2x6 and 2x4 Wood Stud (16" o.c.) Wall Assembly with 2" Gap – Insulated Rim Joist and Floor Intersection	
Detail 8.2.10	B.8.47
	Interior Insulated Double Framed Wall 2x6 and 2x4 Wood Stud (16" o.c.) Wall Assembly with 3" Gap – Insulated Rim Joist and Floor Intersection	
Detail 8.2.11	B.8.48
	Interior Insulated Double Framed Wall 2x6 and 2x4 Wood Stud (16" o.c.) Wall Assembly with 4" Gap – Insulated Rim Joist and Floor Intersection	
Detail 8.2.12	B.8.49
	Exterior and Interior Insulated 2x6 Wood Stud (16" o.c.) Wall Assembly with Shelf Angle & Brick Ties Supporting Brick Veneer and R-19 Batt Insulation in Stud Cavity – Intermediate Floor Intersection	
Detail 8.2.13	B.8.50
	Exterior and Interior Insulated 2x6 Wood Stud (16" o.c.) Wall Assembly with Stand-off (Knife Plate) Shelf Angle & Brick Ties Supporting Brick Veneer and R-19 Batt Insulation in Stud Cavity – Intermediate Floor Intersection	
Detail 8.2.14	B.8.51
	Exterior Insulated 2x6 Wood Stud (16" o.c.) Wall with Interior OSB and Wood Furring Assembly with Stand-off (Knife Plate) Shelf Angle & Brick Ties Supporting Brick Veneer – CLT and Wood Truss Floor Intersection	
Detail 8.2.15	B.8.52
	Exterior and Interior Insulated 2x6 Wood Stud (16" o.c.) Wall with Interior OSB and Wood Furring Assembly with Stand-off (Knife Plate) Shelf Angle & Brick Ties Supporting Brick Veneer – CLT and Wood Truss Floor Intersection	
Detail 8.2.16	B.8.53
	Exterior Insulated 2x6 Wood Stud (16" o.c.) Wall with Interior Wood Furring Assembly with Stand-off (Knife Plate) Shelf Angle & Brick Ties Supporting Brick Veneer – CLT and Wood Truss Floor Intersection	
Detail 8.2.17	B.8.54
	Exterior and Interior Insulated 2x6 Wood Stud (16" o.c.) Wall with Interior Wood Furring Assembly with Stand-off (Knife Plate) Shelf Angle & Brick Ties Supporting Brick Veneer – CLT and Wood Truss Floor Intersection	
Detail 8.2.18	B.8.55
	Exterior and Interior Insulated 2x6 Wood Stud (8" o.c.) Wall Assembly with Wood Strapping and Continuous Insulation Supporting Rainscreen Fiber Cement Board and R-19 Batt Insulation in Stud Cavity – Intermediate Floor Intersection	
Detail 8.2.19	B.8.56

Exterior and Interior Insulated 2x6 Wood Stud (16" o.c.) Wall Assembly with Wood Strapping and Continuous Insulation Supporting Rainscreen Fiber Cement Board and R-19 Batt Insulation in Stud Cavity – Intermediate Floor Intersection	
Detail 8.3.1	B.8.57
Exterior and Interior Insulated 2x6 Wood Stud (16" o.c.) Wall Assembly with Wood Strapping and Continuous Insulation Supporting Rainscreen Fiber Cement Board – Vinyl Window Intersection	
Detail 8.3.2	B.8.58
Exterior and Interior Insulated 2x6 Wood Stud (16" o.c.) Wall Assembly with Wood Strapping and Continuous Insulation Supporting Rainscreen Fiber Cement Board and R-19 Batt Insulation in Stud Cavity – Aluminum Window Intersection	
Detail 8.3.3	B.8.59
Exterior and Interior Insulated 2x6 Wood Stud (8" o.c.) Wall Assembly with Wood Strapping and Continuous Insulation Supporting Rainscreen Fiber Cement Board – Vinyl Window Intersection	
Detail 8.3.4	B.8.60
Exterior Insulated 2x6 Wood Stud (16" o.c.) Wall Assembly with Wood Strapping and Continuous Insulation Supporting Rainscreen Fiber Cement Board – Triple Glazed Flange Mounted Vinyl Window Intersection with Window Positioned in Wood Framing	
Detail 8.3.5	B.8.61
Exterior and Interior Insulated 2x6 Wood Stud (16" o.c.) Wall Assembly with Wood Strapping and Continuous Insulation Supporting Rainscreen Fiber Cement Board and R-19 Batt Insulation in Stud Cavity – Triple Glazed Flange Mounted Vinyl Window Intersection with Window Positioned in Wood Framing	
Detail 8.3.6	B.8.62
Exterior Insulated 2x6 Wood Stud (16" o.c.) Wall Assembly with Wood Strapping (16" o.c.) and Continuous Insulation Supporting Rainscreen Fiber Cement Board – Triple Glazed High Performance Vinyl Window Intersection (Insulated Frames)	
Detail 8.3.7	B.8.63
Exterior and Interior Insulated 2x6 Wood Stud (16" o.c.) Wall Assembly with Wood Strapping (16" o.c.) and Continuous Insulation Supporting Rainscreen Fiber Cement Board and R-19 Batt Insulation in Stud Cavity – Triple Glazed High Performance Vinyl Window Intersection (Insulated Frames)	
Detail 8.3.8	B.8.64
Interior Insulated Cross Laminated Timber (CLT) Spandrel at Window and Dowel Laminated Timber (DLT) – Intermediate Floor Intersection with Edge of Floor and Glulam Beam Aligned	
Detail 8.3.9	B.8.65
Full Height Interior Insulated Cross Laminated Timber (CLT) Spandrel at Window and Dowel Laminated Timber (DLT) – Intermediate Floor Intersection with Edge of Floor and Glulam Beam Aligned	

Detail 8.3.10	B.8.66
Interior Insulated Cross Laminated Timber (CLT) Spandrel at Window and Dowel Laminated Timber (DLT) – Intermediate Floor Intersection with Edge of Floor and Glulam Beam Not Aligned	
Detail 8.3.11	B.8.67
Double Framed Wall with 2x6 and 2x4 Wood Studs (16” o.c.) and 2” Gap – Triple Glazed Flanged Fiberglass Window Intersection with Wood Blocking and Un-insulated Perimeter	
Detail 8.3.12	B.8.68
Double Framed Wall with 2x6 and 2x4 Wood Studs (16” o.c.) and 3” Gap – Triple Glazed Flanged Fiberglass Window Intersection with Wood Blocking and Un-insulated Perimeter	
Detail 8.3.13	B.8.69
Double Framed Wall with 2x6 and 2x4 Wood Studs (16” o.c.) and 4” Gap – Triple Glazed Flanged Fiberglass Window Intersection with Wood Blocking and Un-insulated Perimeter	
Detail 8.3.14	B.8.70
Double Framed Wall with 2x6 and 2x4 Wood Studs (16” o.c.) and 2” Gap – Triple Glazed Flanged Fiberglass Window Intersection with Wood Blocking and Insulated Perimeter	
Detail 8.3.15	B.8.71
Double Framed Wall with 2x6 and 2x4 Wood Studs (16” o.c.) and 3” Gap – Triple Glazed Flanged Fiberglass Window Intersection with Wood Blocking and Insulated Perimeter	
Detail 8.3.16	B.8.72
Double Framed Wall with 2x6 and 2x4 Wood Studs (16” o.c.) and 4” Gap – Triple Glazed Flanged Fiberglass Window Intersection with Wood Blocking and Insulated Perimeter	
Detail 8.3.17	B.8.73
Double Framed Wall with 2x6 and 2x4 Wood Studs (16” o.c.) Wall and 2” Gap – Triple Glazed Rebated Fiberglass Window Intersection and Un-Insulated Perimeter	
Detail 8.3.18	B.8.74
Double Framed Wall with 2x6 and 2x4 Wood Studs (16” o.c.) Wall and 3” Gap – Triple Glazed Rebated Fiberglass Window Intersection and Un-insulated Perimeter	
Detail 8.3.19	B.8.75
Double Framed Wall with 2x6 and 2x4 Wood Studs (16” o.c.) Wall and 4” Gap – Triple Glazed Rebated Fiberglass Window Intersection and Un-insulated Perimeter	
Detail 8.3.20	B.8.76

Double Framed Wall with 2x6 and 2x4 Wood Studs (16" o.c.) Wall and 2" Gap – Triple Glazed Rebated Fiberglass Window Intersection with Insulation at Window Perimeter	
Detail 8.3.21	B.8.77
Double Framed Wall with 2x6 and 2x4 Wood Studs (16" o.c.) Wall and 3" Gap – Triple Glazed Rebated Fiberglass Window Intersection with Insulation at Window Perimeter	
Detail 8.3.22	B.8.78
Double Framed Wall with 2x6 and 2x4 Wood Studs (16" o.c.) Wall and 4" Gap – Triple Glazed Rebated Fiberglass Window Intersection with Insulation at Window Perimeter	
Detail 8.3.23	B.8.79
Exterior and Interior Insulated 2x6 Wood Stud (16" o.c.) Wall Assembly with Wood Strapping and Continuous Insulation Supporting Rainscreen Fiber Cement Board – Double Glazed Aluminum Window Intersection Aligned with Exterior Insulation	
Detail 8.4.1	B.8.80
Exterior and Interior Insulated 2x6 Wood Stud (16" o.c.) Wall Assembly with Wood Strapping and Continuous Insulation Supporting Rainscreen Fiber Cement Board and R-19 Batt Insulation in Stud Cavity – Vented Low-slope Roof & Parapet Intersection	
Detail 8.4.2	B.8.81
Exterior and Interior Insulated 2x6 Wood Stud (16" o.c.) Wall Assembly with Wood Strapping and Continuous Insulation Supporting Fiber Cement Board and R-19 Batt Insulation in Stud Cavity – Sloped Wood Framed Roof & Wall Intersection with Insulation at Ceiling	
Detail 8.4.3	B.8.82
Exterior and Interior Insulated 2x6 Wood Stud (16" o.c.) Wall Assembly with Wood Strapping and Continuous Insulation Supporting Rainscreen Fiber Cement Board and R-19 Batt Insulation in Stud Cavity – Sloped Wood Framed Roof & Wall Intersection with Insulation at Roof Sheathing	
Detail 8.4.4	B.8.83
Ventilated Wood Frame Low Slope Roof – Masonry Firewall Intersection	
Detail 8.4.5	B.8.84
Exterior Insulated Cross Laminated Timber (CLT) Wall Assembly with Continuous Rigid Insulation Supporting Fiber Cement Board –Low-Slope Roof & Parapet Intersection	
Detail 8.5.1	B.8.85
Exterior and Interior Insulated 2x6 Wood Stud (16" o.c.) Wall Assembly with Wood Strapping Supporting and Continuous Insulation Fiber Cement Board and R-19 Batt Insulation in Stud Cavity – Corner Intersection	
Detail 8.5.2	B.8.86

Interior Insulated Double Framed Wall 2x6 and 2x4 Wood Stud (16" o.c.) Wall Assembly with 1" Gap – Corner Intersection	
Detail 8.6.1	B.8.87
Wood-frame Sliding Door – Concrete Floor Intersection for Unheated Spaces (Parking Garages)	
Detail 8.6.2	B.8.88
Exterior and Interior Insulated 2x6 Wood Stud (16" o.c.) Wall Assembly with Continuous Insulation and Wood Strapping Supporting Fiber Cement Board and R-19 Batt Insulation in Stud Cavity – Rim Joist and Interior Insulated At-Grade Foundation Wall Intersection	
Detail 8.6.3	B.8.89
Exterior and Interior Insulated 2x6 Wood Stud (16" o.c.) Wall Assembly with Continuous Insulation and Wood Strapping Supporting Fiber Cement Board and R-19 Batt Insulation in Stud Cavity – Rim Joist and Exterior Insulated At-Grade Foundation Wall Intersection	
Detail 8.6.4	B.8.90
Exterior and Interior Insulated 2x6 Wood Stud (16" o.c.) Wall Assembly with Shelf Angle & Brick Ties Supporting Brick Veneer and R-19 Batt Insulation in Stud Cavity – Exterior Insulated At-Grade Foundation Wall Intersection	
Detail 8.6.5	B.8.91
Exterior Insulated Cross Laminated Timber (CLT) Wall Assembly with Continuous Rigid Insulation Supporting Fiber Cement Board – Concrete Slab and Exterior Insulated At-Grade Foundation Wall Intersection	
Detail 8.6.6	B.8.92
Interior Insulated Double Framed Wall 2x6 and 2x4 Wood Stud (16" o.c.) Wall Assembly with 2" Gap – Rim Joist and Split Insulated At-Grade Foundation Wall Intersection	
Detail 8.6.7	B.8.93
Interior Insulated Double Framed Wall 2x6 and 2x4 Wood Stud (16" o.c.) Wall Assembly with 2" Gap – Insulated Rim Joist and Split Insulated At-Grade Foundation Wall Intersection	
Detail 8.6.8	B.8.94
Interior Insulated Double Framed Wall 2x6 and 2x4 Wood Stud (16" o.c.) Wall Assembly with 2" Gap and R28 ICF Foundation Wall – Rim Joist and Split Insulated At-Grade Foundation Wall Intersection	
Detail 8.6.9	B.8.95
Interior Insulated Double Framed Wall 2x6 and 2x4 Wood Stud (16" o.c.) Wall Assembly with 2" Gap and R43 ICF Foundation Wall – Rim Joist and Split Insulated At-Grade Foundation Wall Intersection	
Detail 8.6.10	B.8.96

Interior Insulated Double Framed Wall 2x6 and 2x4 Wood Stud (16" o.c.) Wall Assembly with 2" Gap and Partially Wrapped R-22.5 Raft Slab Insulation – Slab on Grade Foundation Intersection	
Detail 8.6.11	B.8.97
Interior Insulated Double Framed Wall 2x6 and 2x4 Wood Stud (16" o.c.) Wall Assembly with 2" Gap and Partially Wrapped R-45 Raft Slab Insulation – Slab on Grade Foundation Intersection	
Detail 8.6.12	B.8.98
Interior Insulated Double Framed Wall 2x6 and 2x4 Wood Stud (16" o.c.) Wall Assembly with 2" Gap and Fully Wrapped R-22.5 Raft Slab Insulation – Slab on Grade Foundation Intersection	
Detail 8.6.13	B.8.99
Interior Insulated Double Framed Wall 2x6 and 2x4 Wood Stud (16" o.c.) Wall Assembly with 2" Gap and Fully Wrapped R-45 Raft Slab Insulation – Slab on Grade Foundation Intersection	
Detail 8.6.14	B.8.100
Interior Insulated Double Framed Wall 2x6 and 2x4 Wood Stud (16" o.c.) Wall Assembly with 2" Gap and R-22.5 Slab Insulation with Gravel Base – Slab on Grade Foundation Intersection	
Detail 8.6.15	B.8.101
Interior Insulated Double Framed Wall 2x6 and 2x4 Wood Stud (16" o.c.) Wall Assembly with 2" Gap and R-45 Slab Insulation with Gravel Base – Slab on Grade Foundation Intersection	
Detail 8.7.1	B.8.102
Exterior and Interior Insulated Wood Infill Wall Assembly with Wood Strapping and Continuous Insulation Supporting Fiber Cement Board and R-19 Batt Insulation in Stud Cavity – Concrete Wall and Intermediate Floor Intersection with Flashing Bypassing Exterior Insulation	
Detail 8.7.2	B.8.103
Exterior Insulated Cross Laminated Timber (CLT) Wall Assembly with Wood Strapping and Continuous Rigid Insulation Supporting Fiber Cement Board – Cross Laminated Timber Floor Intersection with Flashing Bypassing Exterior Insulation	
Detail 8.7.3	B.8.104
Exterior and Interior Insulated 2x6 Wood Stud (16" o.c.) Wall Assembly with Wood Strapping and Continuous Insulation Supporting Fiber Cement Board – One-Hour Fire Wall Intersection	

Detail 8.1.1

Interior Insulated 2x4 Wood Stud Wall Assembly – Clear Wall

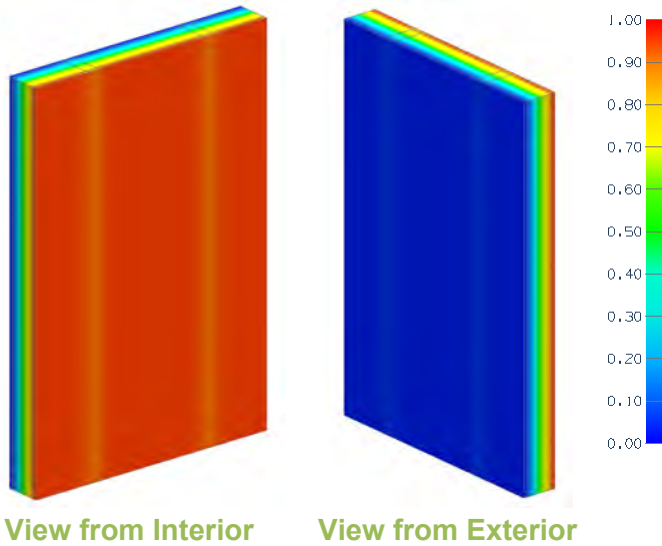

Thermal Performance Indicators

Assembly 1D (Nominal) R-Value	R_{1D}	R-2.5 (0.44 RSI) + interior insulation or R-0.9 (0.16 RSI) for air in stud cavity
Transmittance / Resistance without Anomaly	U_o , R_o	“clear field” U- and R-value

Nominal (1D) vs. Assembly Performance Indicators

Stud Spacing	Stud Cavity Insulation	R_{1D} ft ² ·hr·°F / Btu (m ² K / W)	R_o ft ² ·hr·°F / Btu (m ² K / W)	U_o Btu/ft ² ·hr ·°F (W/m ² K)
16" o.c.	Air	R-3.4 (0.61)	R-3.7 (0.65)	0.272 (1.54)
	R-12.0 (2.11)	R-14.5 (2.56)	R-13.4 (2.37)	0.074 (0.42)
	R-13.0 (2.29)	R-15.5 (2.74)	R-14.2 (2.50)	0.071 (0.40)
24" o.c.	Air	R-3.4 (0.61)	R-3.6 (0.64)	0.275 (1.56)
	R-12.0 (2.11)	R-14.5 (2.56)	R-13.8 (2.43)	0.072 (0.41)
	R-13.0 (2.29)	R-15.5 (2.74)	R-14.6 (2.58)	0.068 (0.39)

Detail 8.1.2

Interior Insulated 2x6 Wood Stud Wall Assembly – Clear Wall

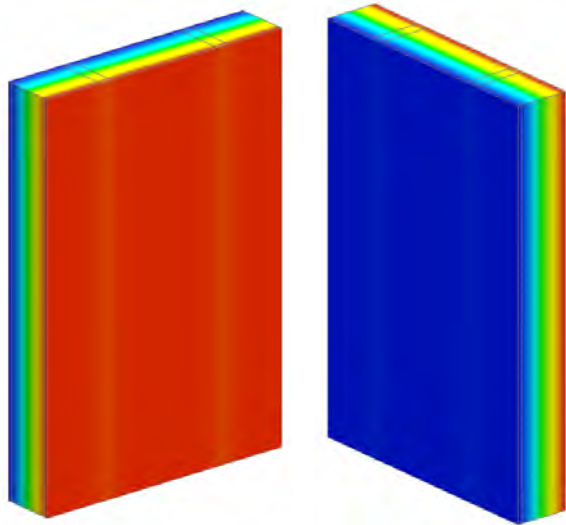

View from Interior

View from Exterior

Thermal Performance Indicators

Assembly 1D (Nominal) R-Value	R_{1D}	R-2.5 (0.44 RSI) + interior insulation or R-0.9 (0.16 RSI) for air in stud cavity
Transmittance / Resistance without Anomaly	U_o, R_o	“clear field” U- and R-value

Nominal (1D) vs. Assembly Performance Indicators

Stud Spacing	Stud Cavity Insulation	R_{1D} ft ² ·hr·°F / Btu (m ² K / W)	R_o ft ² ·hr·°F / Btu (m ² K / W)	U_o Btu/ft ² ·hr ·°F (W/m ² K)
16" o.c.	Air	R-3.4 (0.61)	R-3.7 (0.65)	0.270 (1.54)
	R-19.0 (3.35)	R-21.5 (3.79)	R-19.6 (3.45)	0.051 (0.29)
	R-22.0 (3.87)	R-24.5 (4.32)	R-21.8 (3.83)	0.046 (0.26)
	R-24.0 (4.23)	R-26.5 (4.67)	R-23.1 (4.07)	0.043 (0.25)
	R-26.0 (4.58)	R-28.5 (5.03)	R-24.5 (4.31)	0.041 (0.23)
	R-28.0 (4.93)	R-30.5 (5.38)	R-25.7 (4.53)	0.039 (0.22)
	R-30.0 (5.28)	R-32.5 (5.73)	R-27.0 (4.75)	0.037 (0.21)
24" o.c.	Air	R-3.4 (0.61)	R-3.6 (0.64)	0.274 (1.56)
	R-19.0 (3.35)	R-21.5 (3.79)	R-20.2 (3.57)	0.049 (0.28)
	R-22.0 (3.87)	R-24.5 (4.32)	R-22.6 (3.99)	0.044 (0.25)
	R-24.0 (4.23)	R-26.5 (4.67)	R-24.2 (4.26)	0.041 (0.23)
	R-26.0 (4.58)	R-28.5 (5.03)	R-25.7 (4.53)	0.039 (0.22)
	R-28.0 (4.93)	R-30.5 (5.38)	R-27.2 (4.79)	0.037 (0.21)
	R-30.0 (5.28)	R-32.5 (5.73)	R-28.6 (5.05)	0.035 (0.20)

Detail 8.1.3

Interior Insulated 2x6 Wood Stud (16" o.c.) Wall Assembly with Wood Strapping Supporting Fiber Cement Board and R-19 Batt Insulation in Stud Cavity - Clear Wall

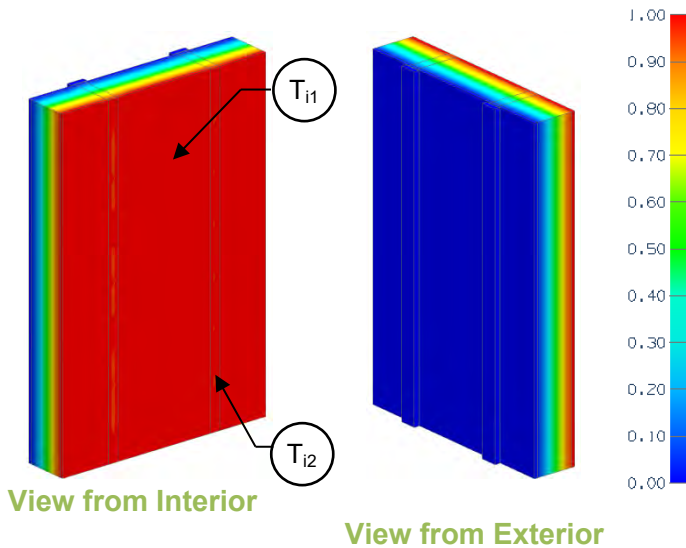

Thermal Performance Indicators

Assembly 1D (Nominal) R-Value	R_{1D}	R-21.5 (3.80 RSI) + exterior insulation
Transmittance / Resistance	U_o, R_o	"clear wall" U- and R-value
Surface Temperature Index ¹	T_i	0 = exterior temperature 1 = interior temperature

¹Assumptions and limitations for surface temperatures identified in ASHRAE 1365-RP

Nominal (1D) vs. Assembly Performance Indicators

R_{1D} ft ² ·hr·°F / Btu (m ² K / W)	R_o ft ² ·hr·°F / Btu (m ² K / W)	U_o Btu/ft ² ·hr·°F (W/m ² K)
R-21.5 (3.80)	R-19.7 (3.47)	0.051 (0.29)

Temperature Indices

T_{i1}	0.06	Min T on sheathing, between studs
T_{i2}	0.12	Max T on sheathing, along studs

Detail 8.1.4

Exterior and Interior Insulated 2x6 Wood Stud (16" o.c.) Wall Assembly with Wood Strapping Supporting Fiber Cement Board and R-19 Batt Insulation in Stud Cavity – Clear Wall

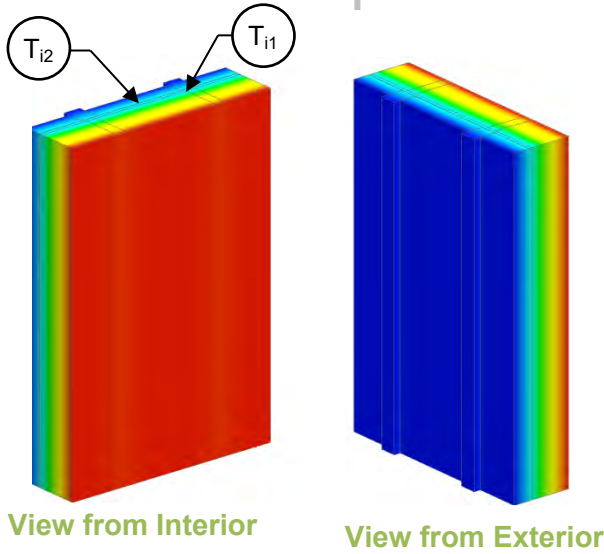

Thermal Performance Indicators

Assembly 1D (Nominal) R-Value	R_{1D}	R-21.7 (3.81 RSI) + exterior insulation
Transmittance / Resistance	U_o, R_o	"clear wall" U- and R-value
Surface Temperature Index ¹	T_i	0 = exterior temperature 1 = interior temperature

¹Assumptions and limitations for surface temperatures identified in ASHRAE 1365-RP

Nominal (1D) vs. Assembly Performance Indicators

Exterior Insulation 1D R-Value (RSI)	R_{1D} ft ² ·hr·°F / Btu (m ² K / W)	R_o ft ² ·hr·°F / Btu (m ² K / W)	U_o Btu/ft ² ·hr ·°F (W/m ² K)
R-5 (0.88)	R-26.5 (4.67)	R-23.8 (4.19)	0.042 (0.24)
R-10 (1.76)	R-31.5 (5.55)	R-27.6 (4.86)	0.036 (0.21)
R-15 (2.64)	R-36.5 (6.44)	R-31.3 (5.51)	0.032 (0.18)
R-20 (3.52)	R-41.5 (7.32)	R-34.9 (6.15)	0.029 (0.16)
R-25 (4.40)	R-46.5 (8.20)	R-38.6 (6.79)	0.026 (0.15)

Temperature Indices

	R5	R10	R15	R20	R25	
T_{i1}	0.23	0.33	0.41	0.47	0.52	Min T on sheathing, adjacent to studs
T_{i2}	0.24	0.35	0.43	0.50	0.54	Max T on sheathing, between studs at centre of stud cavity

Detail 8.1.5

Exterior and Interior Insulated 2x6 Wood Stud (16" o.c.) Wall Assembly with Continuous Rigid Insulation Supporting Fiber Cement Board and R-19 Batt Insulation in Stud Cavity – Clear Wall

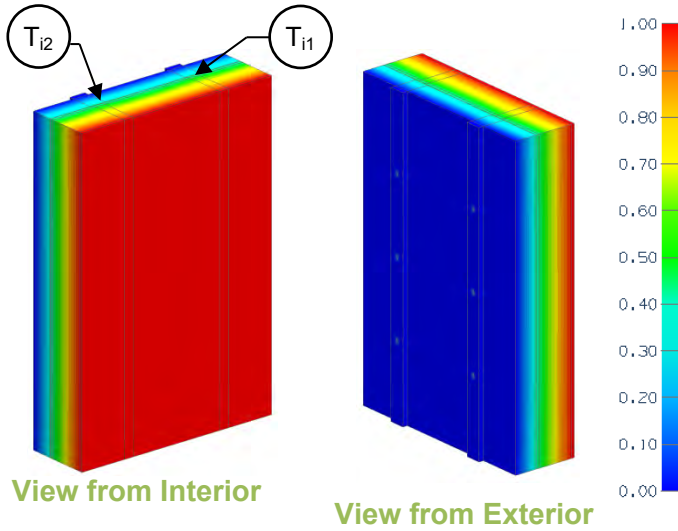

Thermal Performance Indicators

Assembly 1D (Nominal) R-Value	R_{1D}	R-21.5 (3.80 RSI) + exterior insulation
Transmittance / Resistance	U_o, R_o	"clear wall" U- and R-value
Surface Temperature Index ¹	T_i	0 = exterior temperature 1 = interior temperature

¹Assumptions and limitations for surface temperatures identified in ASHRAE 1365-RP

Nominal (1D) vs. Assembly Performance Indicators

Exterior Insulation 1D R-Value (RSI)	R_{1D} ft ² ·hr·°F / Btu (m ² K / W)	R_o ft ² ·hr·°F / Btu (m ² K / W)	U_o Btu/ft ² ·hr·°F (W/m ² K)
R-5.0 (0.88)	R-26.5 (4.68)	R-24.6 (4.32)	0.041 (0.23)
R-10.0 (1.76)	R-31.5 (5.56)	R-29.2 (5.14)	0.034 (0.20)
R-15.0 (2.64)	R-36.5 (6.44)	R-33.6 (5.92)	0.030 (0.17)
R-20.0 (3.52)	R-41.5 (7.32)	R-37.8 (6.66)	0.026 (0.15)
R-25.0 (4.40)	R-46.5 (8.20)	R-41.9 (7.37)	0.024 (0.14)

Temperature Indices

	R5	R10	R15	R20	R25	
T_{i1}	0.25	0.35	0.41	0.46	0.50	Min T on sheathing, at fasteners along studs
T_{i2}	0.32	0.42	0.50	0.57	0.59	Max T on sheathing, between fasteners along studs

Detail 8.1.6

Exterior and Interior Insulated 2x6 Wood Stud (16" o.c.) Wall Assembly with Horizontal Metal Z-Girts (24" o.c.) Supporting Fiber Cement Board and R-19 Batt Insulation in Stud Cavity – Clear Wall

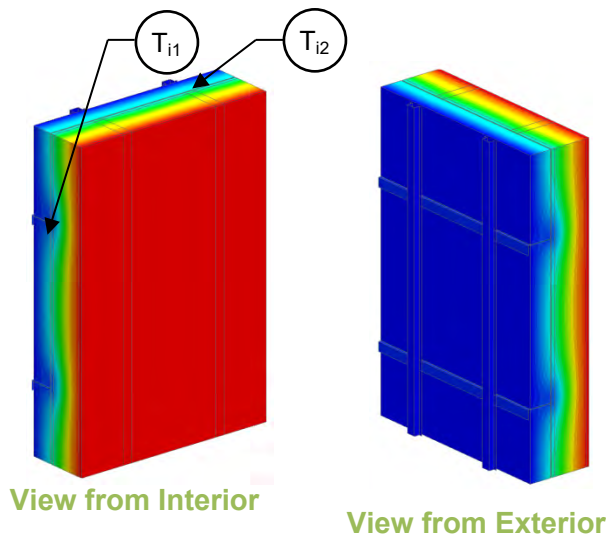

Thermal Performance Indicators



Assembly 1D (Nominal) R-Value	R_{1D}	R-21.6 (3.80 RSI) + exterior insulation
Transmittance / Resistance	U_o, R_o	"clear wall" U- and R-value
Surface Temperature Index ¹	T_i	0 = exterior temperature 1 = interior temperature

¹Assumptions and limitations for surface temperatures identified in ASHRAE 1365-RP

Nominal (1D) vs. Assembly Performance Indicators

Exterior Insulation 1D R-Value (RSI)	R_{1D} ft ² ·hr·°F / Btu (m ² K / W)	R_o ft ² ·hr·°F / Btu (m ² K / W)	U_o Btu/ft ² ·hr ·°F (W/m ² K)
R-5 (0.88)	R-26.5 (4.67)	R-23.4 (4.12)	0.043 (0.24)
R-10 (1.76)	R-31.5 (5.55)	R-26.4 (4.64)	0.038 (0.22)
R-15 (2.64)	R-36.5 (6.44)	R-28.7 (5.06)	0.035 (0.20)
R-20 (3.52)	R-41.5 (7.32)	R-30.8 (5.42)	0.032 (0.18)
R-25 (4.40)	R-46.5 (8.20)	R-32.6 (5.73)	0.031 (0.17)

Temperature Indices

	R5	R10	R15	R20	R25	
T_{i1}	0.12	0.15	0.18	0.20	0.22	Min T on sheathing, along horizontal Z-girts
T_{i2}	0.30	0.41	0.48	0.53	0.56	Max T on sheathing, at studs between horizontal Z-girts

Detail 8.1.7

Exterior Insulated 2x6 Wood Stud (16" o.c.) Wall Assembly with Knight MFI-System (24" o.c.) Supporting Cladding – Clear Wall

Thermal Performance Indicators

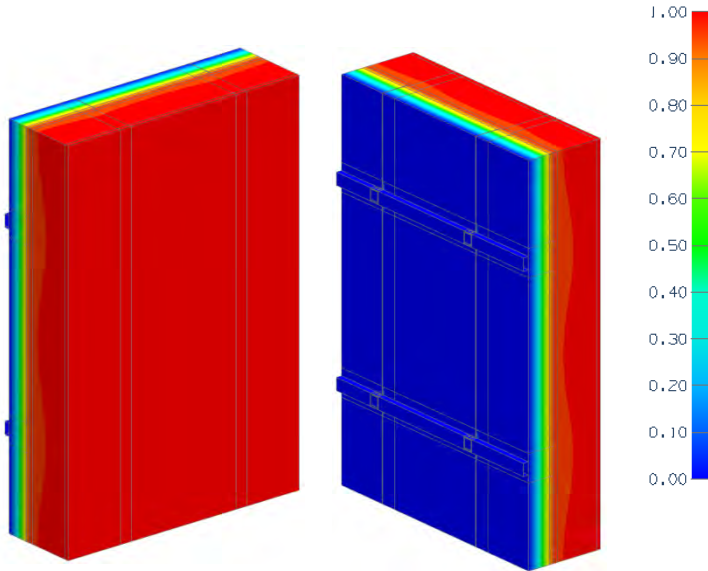

Assembly 1D (Nominal) R-Value	R_{1D}	R-3.2 (0.56 RSI) + exterior insulation
Transmittance / Resistance	U_o, R_o	“clear wall” U- and R-value

View from Interior

View from Exterior

Nominal (1D) vs. Assembly Performance Indicators

Exterior Insulation 1D R-Value (RSI)	R_{1D} ft ² ·hr·°F / Btu (m ² K / W)	R_o ft ² ·hr·°F / Btu (m ² K / W)	U_o Btu/ft ² ·hr ·°F (W/m ² K)
R-8.4 (1.48)	R-11.6 (2.04)	R-11.1 (1.95)	0.090 (0.51)
R-12.6 (2.22)	R-15.8 (2.78)	R-14.6 (2.57)	0.069 (0.39)
R-14.7 (2.59)	R-17.9 (3.15)	R-16.2 (2.85)	0.062 (0.35)
R-16.8 (2.96)	R-20.0 (3.52)	R-17.8 (3.13)	0.056 (0.32)
R-21.0 (3.70)	R-24.2 (4.26)	R-20.8 (3.66)	0.048 (0.28)
R-25.2 (4.44)	R-28.4 (5.00)	R-23.6 (4.16)	0.042 (0.24)

Detail 8.1.8

Exterior and Interior Insulated 2x6 Wood Stud (16" o.c.) Wall Assembly with Knight MFI-System (24" o.c.) Supporting Cladding and R-19 Batt Insulation in Stud Cavity – Clear Wall

Thermal Performance Indicators

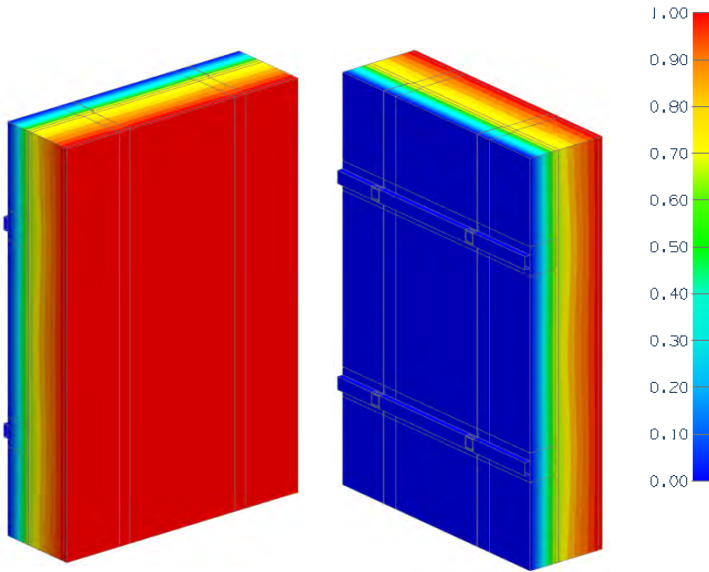

Assembly 1D (Nominal) R-Value	R_{1D}	R-21.3 (3.75 RSI) + exterior insulation
Transmittance / Resistance	U_o , R_o	"clear wall" U- and R-value

View from Interior

View from Exterior

Nominal (1D) vs. Assembly Performance Indicators

Exterior Insulation 1D R-Value (RSI)	R_{1D} ft ² ·hr·°F / Btu (m ² K / W)	R_o ft ² ·hr·°F / Btu (m ² K / W)	U_o Btu/ft ² ·hr ·°F (W/m ² K)
R-8.4 (1.48)	R-29.7 (5.23)	R-26.4 (4.65)	0.038 (0.22)
R-12.6 (2.22)	R-33.9 (5.97)	R-29.9 (5.27)	0.033 (0.19)
R-14.7 (2.59)	R-36.0 (6.34)	R-31.6 (5.57)	0.032 (0.18)
R-16.8 (2.96)	R-38.1 (6.71)	R-33.2 (5.85)	0.030 (0.17)
R-21.0 (3.70)	R-42.3 (7.45)	R-36.3 (6.39)	0.028 (0.16)
R-25.2 (4.44)	R-46.5 (8.19)	R-39.2 (6.90)	0.025 (0.14)

Detail 8.1.9

Exterior Insulated 2x6 Wood Stud (16" o.c.) Wall Assembly with Thermally Broken Aluminum Clip Rail System (24" o.c.) Supporting Cladding – Clear Wall

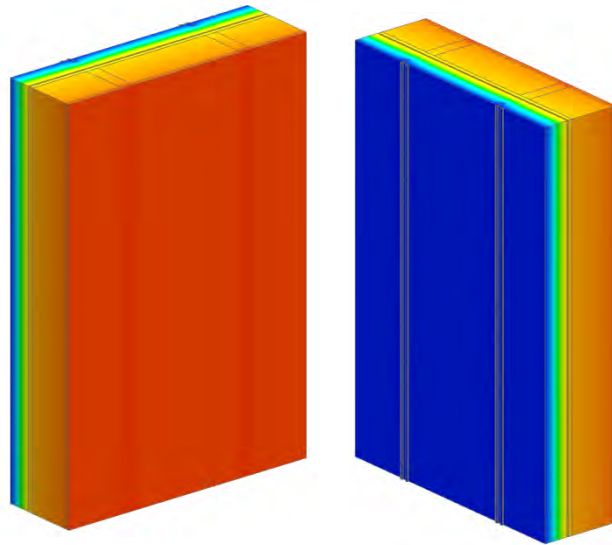

View from Interior

View from Exterior

Thermal Performance Indicators

Assembly 1D (Nominal) R-Value	R_{1Da}	R-2.6 (0.46 RSI) + exterior insulation and fiberglass batt insulation
Assembly 1D (Nominal) R-Value	R_{1Db}	R-20.6 (3.63 RSI) + exterior insulation (with fiberglass batt insulation)
Transmittance / Resistance	$U_a,$ $R_a,$ $U_b,$ R_b	“Clear wall” U- and R-value: a = without batt insulation b = with batt insulation

¹If insulation in stud cavity is used, R-0.9 insulation for the cavity space is eliminated

Nominal (1D) vs. Assembly Performance Indicators

Clear Wall – Without Fiberglass Batt Insulation in Stud Cavity

Exterior Insulation 1D R-Value (RSI)	R_{1Da} ft ² ·hr·°F / Btu (m ² K / W)	R_a ft ² ·hr·°F / Btu (m ² K / W)	U_a Btu/ft ² ·hr ·°F (W/m ² K)
R-12.6 (2.22)	R-15.2 (2.68)	R-15.4 (2.73)	0.065 (0.37)

Clear Wall – With Fiberglass Batt Insulation in Stud Cavity

Exterior Insulation 1D R-Value (RSI)	R_{1Db} ft ² ·hr·°F / Btu (m ² K / W)	R_b ft ² ·hr·°F / Btu (m ² K / W)	U_b Btu/ft ² ·hr ·°F (W/m ² K)
R-12.6 (2.22)	R-33.2 (5.85)	31.3 (5.49)	0.032 (0.18)

Detail 8.1.10

Interior Insulated Double Framed Wall 2x6 and 2x4 Wood Stud (16" o.c.) Wall Assembly with 2" Gap – Clear Wall

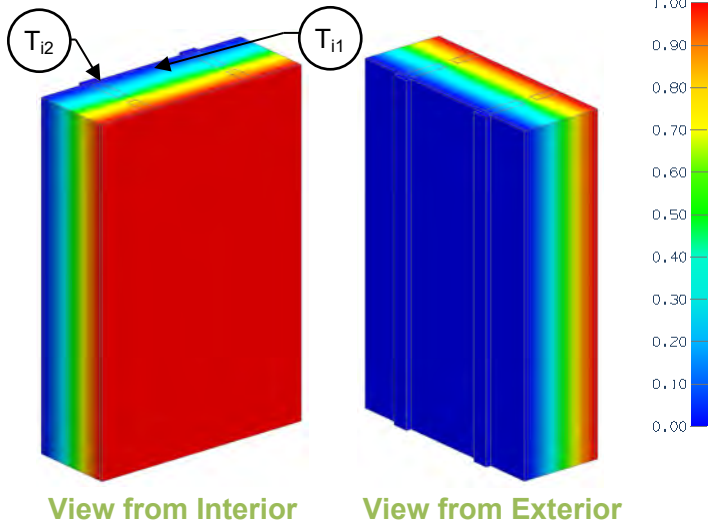

Thermal Performance Indicators

Assembly 1D (Nominal) R-Value	R_{1D}	R-2.5 (0.44 RSI) + exterior insulation
Transmittance / Resistance without Anomaly	U_o, R_o	"clear field" U- and R-value, without connectors or joint
Surface Temperature Index ¹	T_i	0 = exterior temperature 1 = interior temperature

Nominal (1D) vs. Assembly Performance Indicators

Insulation R/in	Fill Insulation 1D R-Value (RSI)	R_{1D} ft ² ·hr·°F / Btu (m ² K / W)	R_o ft ² ·hr·°F / Btu (m ² K / W)	U_o Btu/ft ² ·hr ·°F (W/m ² K)
3.5	R-38.5 (6.78)	R-41.0 (7.23)	R-38.0 (6.70)	0.026 (0.15)
4	R-44.0 (7.75)	R-46.5 (8.19)	R-42.4 (7.47)	0.024 (0.13)
5	R-55.0 (9.69)	R-57.5 (10.13)	R-50.8 (8.94)	0.020 (0.11)
6	R-66.0 (11.62)	R-68.5 (12.07)	R-58.9 (10.37)	0.017 (0.10)

Temperature Indices

	R38.5	R44	R55	R66	
T_{i1}	0.029	0.028	0.024	0.020	Min T on sheathing, between studs
T_{i2}	0.070	0.068	0.064	0.061	Max T on sheathing, at studs

Detail 8.1.11

Interior Insulated Double Framed Wall 2x6 and 2x4 Wood Stud (16" o.c.) Wall Assembly with 3" Gap – Clear Wall

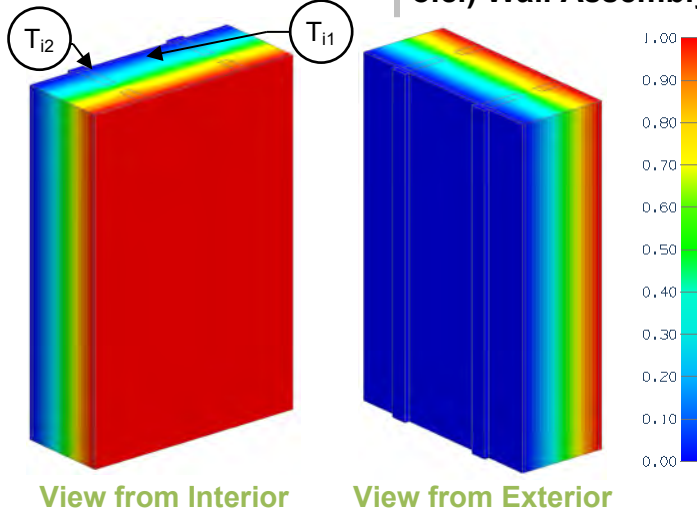

Thermal Performance Indicators

Assembly 1D (Nominal) R-Value	R_{1D}	R-2.5 (0.44 RSI) + insulation
Transmittance / Resistance without Anomaly	U_o, R_o	"clear field" U- and R-value, without connectors or joint
Surface Temperature Index ¹	T_i	0 = exterior temperature 1 = interior temperature

Nominal (1D) vs. Assembly Performance Indicators

Insulation R/in	Fill Insulation 1D R-Value (RSI)	R_{1D} ft ² ·hr·°F / Btu (m ² K / W)	R_o ft ² ·hr·°F / Btu (m ² K / W)	U_o Btu/ft ² ·hr·°F (W/m ² K)
3.5	R-42.0 (7.40)	R-44.5 (7.84)	R-41.6 (7.32)	0.024 (0.14)
4	R-48.0 (8.45)	R-50.5 (8.90)	R-46.4 (8.18)	0.022 (0.12)
5	R-60.0 (10.57)	R-62.5 (11.01)	R-55.9 (9.84)	0.018 (0.10)
6	R-72.0 (12.68)	R-74.5 (13.13)	R-65.0 (11.45)	0.015 (0.09)

Temperature Indices

	R42	R48	R60	R72	
T_{i1}	0.027	0.025	0.022	0.018	Min T on sheathing, between studs
T_{i2}	0.064	0.061	0.058	0.055	Max T on sheathing, at studs

Detail 8.1.12

Interior Insulated Double Framed Wall 2x6 and 2x4 Wood Stud (16" o.c.) Wall Assembly with 4" Gap – Clear Wall

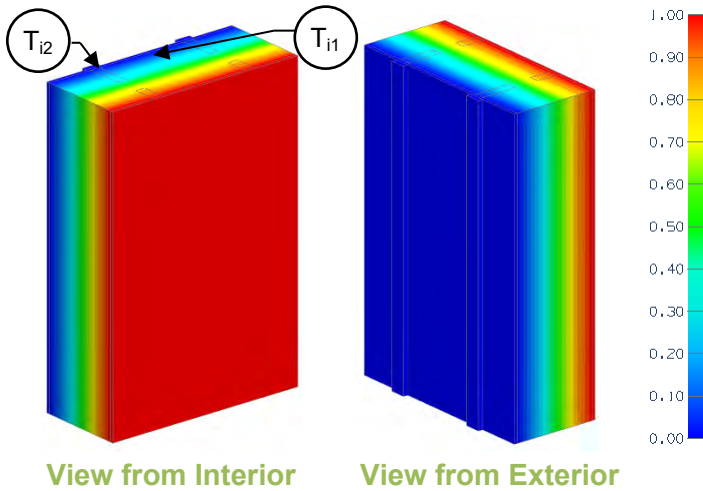

Thermal Performance Indicators

Assembly 1D (Nominal) R-Value	R_{1D}	R-2.5 (0.44 RSI) + insulation
Transmittance / Resistance without Anomaly	U_o, R_o	“clear field” U- and R-value, without connectors or joint
Surface Temperature Index ¹	T_i	0 = exterior temperature 1 = interior temperature

Nominal (1D) vs. Assembly Performance Indicators

Insulation R/in	Fill Insulation 1D R-Value (RSI)	R_{1D} ft ² ·hr·°F / Btu (m ² K / W)	R_o ft ² ·hr·°F / Btu (m ² K / W)	U_o Btu/ft ² ·hr ·°F (W/m ² K)
3.5	R-45.5 (8.01)	R-48.0 (8.46)	R-45.1 (7.94)	0.022 (0.13)
4	R-52.0 (9.16)	R-54.5 (9.60)	R-50.5 (8.89)	0.020 (0.11)
5	R-65.0 (11.45)	R-67.5 (11.89)	R-60.9 (10.73)	0.016 (0.09)
6	R-78.0 (13.74)	R-80.5 (14.18)	R-71.1 (12.52)	0.014 (0.08)

Temperature Indices

	R45.5	R52	R65	R78	
T_{i1}	0.025	0.023	0.020	0.017	Min T on sheathing, between studs
T_{i2}	0.059	0.056	0.053	0.050	Max T on sheathing, at studs

Detail 8.1.13

Interior Insulated Cross Laminated Timber (CLT) Spandrel with ISO-CONNECT Anchor – Anchor Point Transmittance

Thermal Performance Indicators

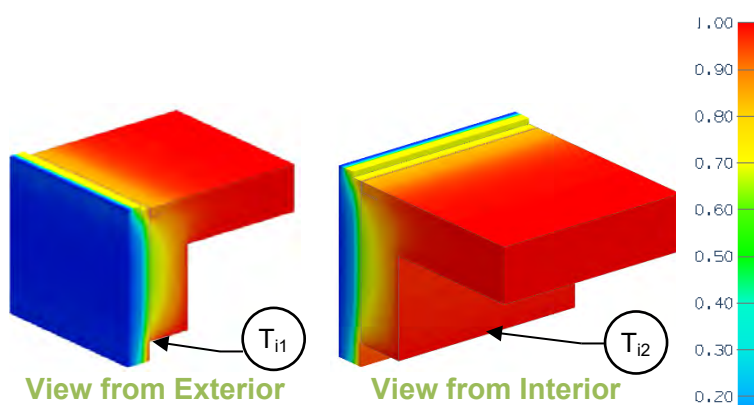

Assembly 1D (Nominal) R-Value at Beam	R_{1D}	R-15.4 (2.71 RSI) + insulation
Transmittance / Resistance without Anomaly	U_o, R_o	U- and R-values for the assembly without connector
Transmittance / Resistance	U, R	U and R-values for the overall assembly
Point Transmittance	χ	Incremental increase in transmittance per connector

Assembly Performance Indicators

Base Assembly – Without Connector

ISO-CONNECT Spacing	Spandrel Insulation 1D R-Value (RSI)	R_{1D} ft ² ·hr·°F / Btu (m ² K / W)	R_o ft ² ·hr·°F / Btu (m ² K / W)	U_o Btu/ft ² ·hr ·°F (W/m ² K)
36" o.c.	R-8.4 (1.48)	R-23.8 (4.18)	R-13.7 (2.41)	0.073 (0.42)
	R-16.8 (2.96)	R-32.2 (5.66)	R-16.8 (2.96)	0.059 (0.34)
	R-25.2 (4.44)	R-40.6 (7.14)	R-18.9 (3.34)	0.053 (0.30)
	R-33.6 (5.92)	R-49.0 (8.62)	R-20.3 (3.58)	0.049 (0.28)

Connector Point Transmittance

ISO-CONNECT Spacing	Spandrel Insulation 1D R-Value (RSI)	R_{1D} ft ² ·hr·°F / Btu (m ² K / W)	R ft ² ·hr·°F / Btu (m ² K / W)	U Btu/ft ² ·hr ·°F (W/m ² K)	χ Btu/hr·°F (W/K)
36" o.c.	R-8.4 (1.48)	R-23.8 (4.18)	R-13.0 (2.29)	0.077 (0.44)	0.031 (0.016)
	R-16.8 (2.96)	R-32.2 (5.66)	R-15.6 (2.76)	0.064 (0.36)	0.038 (0.020)
	R-25.2 (4.44)	R-40.6 (7.14)	R-17.3 (3.05)	0.058 (0.33)	0.042 (0.022)
	R-33.6 (5.92)	R-49.0 (8.62)	R-18.5 (3.25)	0.054 (0.31)	0.041 (0.022)

Temperature Indices

	R-8.4	R-16.8	R-25.2	R-33.6	
T_{i1}	0.90	0.94	0.96	0.97	Min T on beam, at insulation, between connectors
T_{i2}	0.90	0.93	0.94	0.95	Min T on beam, at insulation, along connector

Detail 8.1.14

Exterior and Interior Insulated 2"x6" Wood Stud (16" o.c. and 24" o.c.) Wall Assembly with Heckmann Pos-I-Tie Veneer Anchoring System Supporting Brick Veneer and Owens Corning R-19 Batt Insulation in Stud Cavity – Clear Wall

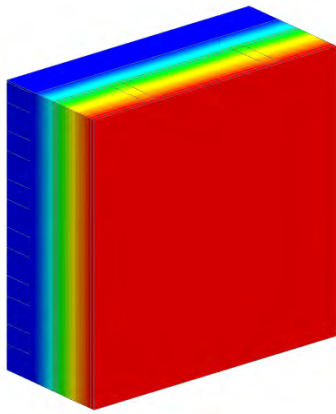

View from Interior

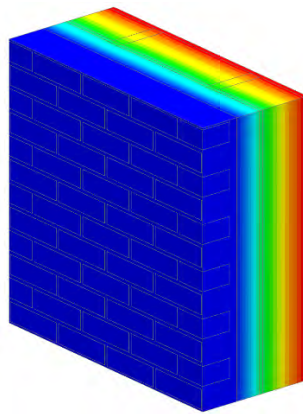

View from Exterior



Thermal Performance Indicators

Assembly 1D (Nominal) R-Value	R_{1D}	R-22.6 (3.98 RSI) + exterior insulation
Transmittance / Resistance without Anomaly	U_o , R_o	"clear wall" U- and R-value

¹Assumptions and limitations for surface temperatures identified in ASHRAE 1365-RP

Nominal (1D) vs. Assembly Performance Indicators

Exterior Insulation 1D R-Value (RSI)	R_{1D} ft ² ·hr·°F / Btu (m ² K / W)	16" o.c. Stud Spacing		24" o.c. Stud Spacing	
		R_o ft ² ·hr·°F / Btu (m ² K / W)	U_o Btu/ft ² ·hr·°F (W/m ² K)	R_o ft ² ·hr·°F / Btu (m ² K / W)	U_o Btu/ft ² ·hr·°F (W/m ² K)
R-10.0 (1.76)	R-32.6 (5.74)	R-29.6 (5.21)	0.034 (0.19)	R-30.6 (5.39)	0.033 (0.19)
R-15.0 (2.64)	R-37.6 (6.62)	R-33.6 (5.92)	0.030 (0.17)	R-35.0 (6.16)	0.029 (0.16)
R-20.0 (3.52)	R-42.6 (7.50)	R-37.4 (6.59)	0.027 (0.15)	R-39.1 (6.89)	0.026 (0.15)

Detail 8.1.15

Exterior and Interior Insulated 2"x6" Wood Stud (16" o.c. and 24" o.c.) Wall Assembly with Heckmann Pos-I-Tie Veneer Anchoring System Supporting Brick Veneer and Owens Corning R-22 Batt Insulation in Stud Cavity – Clear Wall

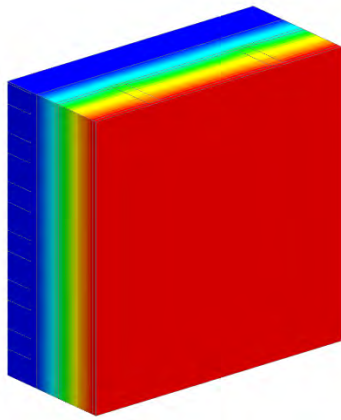

View from Interior

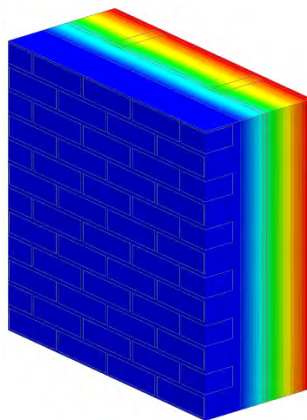

View from Exterior



Thermal Performance Indicators

Assembly 1D (Nominal) R-Value	R_{1D}	R-25.6 (4.51 RSI) + exterior insulation
Transmittance / Resistance without Anomaly	U_o , R_o	"clear wall" U- and R-value

¹Assumptions and limitations for surface temperatures identified in ASHRAE 1365-RP

Nominal (1D) vs. Assembly Performance Indicators

Exterior Insulation 1D R-Value (RSI)	R_{1D} ft ² ·hr·°F / Btu (m ² K / W)	16" o.c. Stud Spacing		24" o.c. Stud Spacing	
		R_o ft ² ·hr·°F / Btu (m ² K / W)	U_o Btu/ft ² ·hr·°F (W/m ² K)	R_o ft ² ·hr·°F / Btu (m ² K / W)	U_o Btu/ft ² ·hr·°F (W/m ² K)
R-10.0 (1.76)	R-35.6 (6.27)	R-31.7 (5.58)	0.032 (0.18)	R-33.0 (5.82)	0.030 (0.17)
R-15.0 (2.64)	R-40.6 (7.15)	R-35.8 (6.30)	0.028 (0.16)	R-37.3 (6.58)	0.027 (0.15)
R-20.0 (3.52)	R-45.6 (8.03)	R-39.6 (6.97)	0.025 (0.14)	R-41.3 (7.28)	0.024 (0.14)

Detail 8.1.16

Exterior and Interior Insulated 2"x6" Wood Stud (16" o.c. and 24" o.c.) Wall Assembly with Heckmann Pos-I-Tie Veneer Anchoring System Supporting Brick Veneer and Owens Corning R-24 Batt Insulation in Stud Cavity – Clear Wall

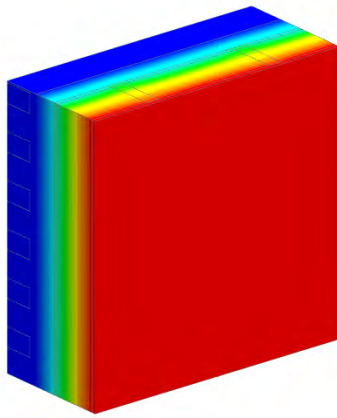

View from Interior

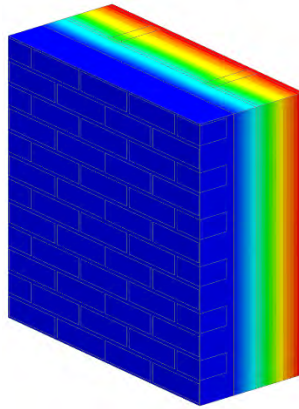

View from Exterior



Thermal Performance Indicators

Assembly 1D (Nominal) R-Value	R_{1D}	R-27.6 (4.86 RSI) + exterior insulation
Transmittance / Resistance without Anomaly	U_o , R_o	"clear wall" U- and R-value

¹Assumptions and limitations for surface temperatures identified in ASHRAE 1365-RP

Nominal (1D) vs. Assembly Performance Indicators

Exterior Insulation 1D R-Value (RSI)	R_{1D} ft ² ·hr·°F / Btu (m ² K / W)	16" o.c. Stud Spacing		24" o.c. Stud Spacing	
		R_o ft ² ·hr·°F / Btu (m ² K / W)	U_o Btu/ft ² ·hr·°F (W/m ² K)	R_o ft ² ·hr·°F / Btu (m ² K / W)	U_o Btu/ft ² ·hr·°F (W/m ² K)
R-10.0 (1.76)	R-37.6 (6.62)	R-33.2 (5.84)	0.030 (0.17)	R-34.7 (6.11)	0.029 (0.16)
R-15.0 (2.64)	R-42.6 (7.50)	R-37.1 (6.53)	0.027 (0.15)	R-39.0 (6.86)	0.026 (0.15)
R-20.0 (3.52)	R-47.6 (8.38)	R-41.0 (7.22)	0.024 (0.14)	R-42.9 (7.56)	0.023 (0.13)

Detail 8.1.17

Exterior Insulated Cross Laminated Timber (CLT) Wall Assembly with Continuous Rigid Insulation Supporting Fiber Cement Board – Clear Wall

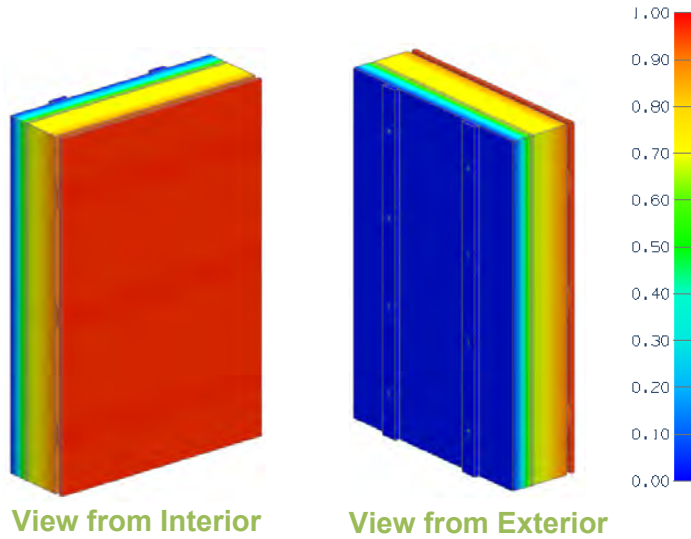

Thermal Performance Indicators

Assembly 1D (Nominal) R-Value	R_{1D}	R-9.9 (1.74 RSI) + exterior insulation
Transmittance / Resistance	U_o, R_o	“clear wall” U- and R-value

Nominal (1D) vs. Assembly Performance Indicators

Exterior Insulation 1D R-Value (RSI)	R_{1D} ft ² ·hr·°F / Btu (m ² K / W)	R_o ft ² ·hr·°F / Btu (m ² K / W)	U_o Btu/ft ² ·hr·°F (W/m ² K)
R-0.0 (0.00)	R-9.9 (1.74)	R-10.0 (1.77)	0.100 (0.57)
R-15.0 (2.64)	R-24.9 (4.38)	R-24.7 (4.35)	0.040 (0.23)
R-20.0 (3.52)	R-29.9 (5.26)	R-29.4 (5.17)	0.034 (0.19)
R-25.0 (4.40)	R-34.9 (6.14)	R-33.9 (5.98)	0.029 (0.17)

Detail 8.1.18

Exterior Insulated Cross Laminated Timber (CLT) Wall Assembly with Wood Strapping and Continuous Rigid Insulation Supporting Fiber Cement Board

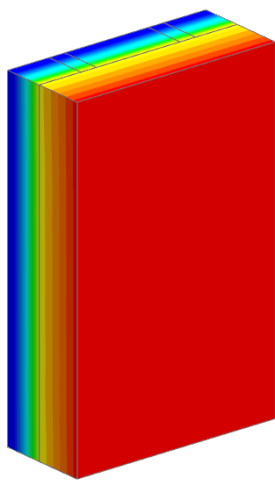

View from Interior

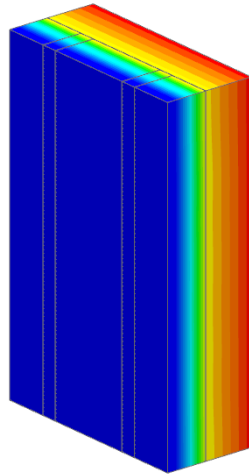

View from Exterior



Thermal Performance Indicators

Assembly 1D (Nominal) R-Value	R_{1D}	R-10.5 (1.85 RSI) + exterior insulation
Transmittance / Resistance without Anomaly	U_o, R_o	“clear wall” U- and R-value, without CLT floor slab

Nominal (1D) vs. Assembly Performance Indicators

Exterior Insulation 1D R-Value (RSI)	R_{1D} ft ² ·hr·°F / Btu (m ² K / W)	R_o ft ² ·hr·°F / Btu (m ² K / W)	U_o Btu/ft ² ·hr·°F (W/m ² K)
R-0.0 (0.00)	R-10.5 (1.84)	R-9.9 (1.75)	0.101 (0.57)
R-15.0 (2.64)	R-25.5 (4.49)	R-24.5 (4.31)	0.041 (0.23)
R-20.0 (3.52)	R-30.5 (5.37)	R-28.6 (5.05)	0.035 (0.20)
R-25.0 (4.40)	R-35.5 (6.25)	R-31.1 (5.48)	0.032 (0.18)

Detail 8.1.19

Exterior and Interior Insulated 2x6 Wood Stud (16" o.c.) Wall Assembly with Brick Ties Supporting Brick Veneer and R-19 Batt Insulation in Stud Cavity – Clear Wall

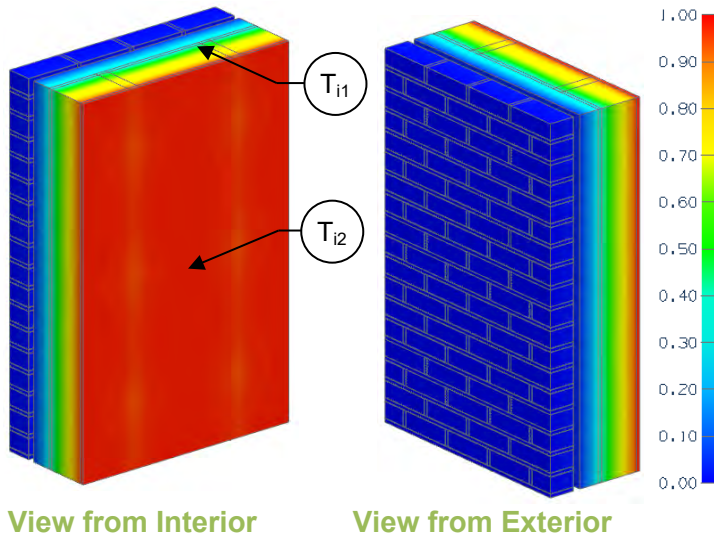

Thermal Performance Indicators

Assembly 1D (Nominal) R-Value	R_{1D}	R-27.4 (4.83 RSI) + exterior insulation
Transmittance / Resistance without Anomaly	U_o, R_o	“clear wall” U- and R-value
Surface Temperature Index ¹	T_i	0 = exterior temperature 1 = interior temperature

¹Assumptions and limitations for surface temperatures identified in ASHRAE 1365-RP

Nominal (1D) vs. Assembly Performance Indicators

Exterior Insulation 1D R-Value (RSI)	R_{1Dw} ft ² ·hr·°F / Btu (m ² K / W)	R_w ft ² ·hr·°F / Btu (m ² K / W)	U_w Btu/ft ² ·hr·°F (W/m ² K)
R-0 (0.00)	R-27.4 (4.83)	R-19.8 (3.49)	0.050 (0.29)
R-5 (0.88)	R-32.4 (5.71)	R-24.1 (4.25)	0.041 (0.24)
R-10 (1.76)	R-37.4 (6.59)	R-28.0 (4.93)	0.036 (0.20)
R-15 (2.64)	R-42.4 (7.47)	R-31.5 (5.54)	0.032 (0.18)

Temperature Indices

	R0	R5	R10	R15	
T_{i1}	0.18	0.28	0.34	0.39	T on sheathing, at studs near brick ties
T_{i2}	0.15	0.33	0.42	0.50	T on sheathing, at studs between brick ties

Detail 8.1.20

Exterior Insulated 2x6 Wood Stud (16" o.c.) Wall with Interior OSB and Wood Furring Assembly & Brick Ties Supporting Brick Veneer – Clear Wall

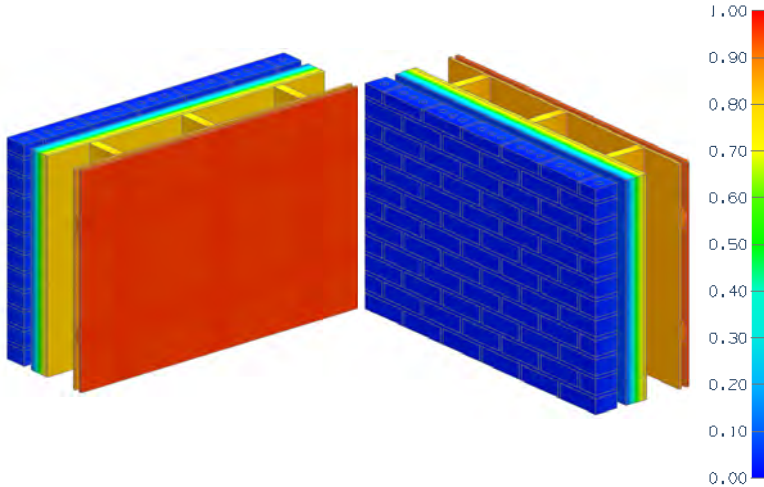

View from Interior

View from Exterior

Thermal Performance Indicators

Assembly 1D (Nominal) R-Value	R_{1D}	R-5.3 (0.93 RSI) + exterior insulation
Transmittance / Resistance without Anomaly	U_o, R_o	"clear wall" U- and R-value

Nominal (1D) vs. Assembly Performance Indicators

Exterior Insulation 1D R-Value (RSI)	R_{1D} ft ² ·hr·°F / Btu (m ² K / W)	R_o ft ² ·hr·°F / Btu (m ² K / W)	U_o Btu/ft ² ·hr ·°F (W/m ² K)
R-10 (1.76)	R-15.3 (2.69)	R-14.3 (2.52)	0.070 (0.40)
R-15 (2.64)	R-20.3 (3.57)	R-17.9 (3.15)	0.056 (0.32)
R-20 (3.52)	R-25.3 (4.45)	R-21.1 (3.72)	0.047 (0.27)
R-25 (4.40)	R-30.3 (5.33)	R-24.1 (4.24)	0.041 (0.24)
R-30 (5.28)	R-35.3 (6.21)	R-26.9 (4.73)	0.037 (0.21)

Detail 8.1.21

Exterior and Interior Insulated 2x6 Wood Stud (16" o.c.) Wall with Interior OSB and Wood Furring Assembly & Brick Ties Supporting Brick Veneer – Clear Wall

Thermal Performance Indicators

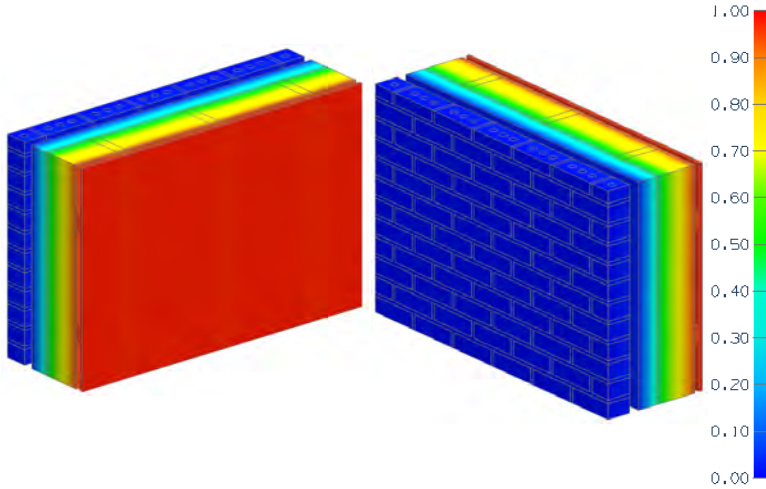

Assembly 1D (Nominal) R-Value	R_{1D}	R-23.4 (4.12 RSI) + exterior insulation
Transmittance / Resistance without Anomaly	U_o, R_o	"clear wall" U- and R-value

View from Interior

View from Exterior

Nominal (1D) vs. Assembly Performance Indicators

Exterior Insulation 1D R-Value (RSI)	R_{1D} ft ² ·hr·°F / Btu (m ² K / W)	R_o ft ² ·hr·°F / Btu (m ² K / W)	U_o Btu/ft ² ·hr ·°F (W/m ² K)
R-5 (0.88)	R-28.4 (5.00)	R-26.2 (4.62)	0.038 (0.22)
R-10 (1.76)	R-33.4 (5.88)	R-30.3 (5.34)	0.033 (0.19)
R-15 (2.64)	R-38.4 (6.76)	R-34.0 (5.99)	0.029 (0.17)
R-20 (3.52)	R-43.4 (7.64)	R-37.4 (6.58)	0.027 (0.15)
R-25 (4.40)	R-48.4 (8.52)	R-40.5 (7.12)	0.025 (0.14)
R-30 (5.28)	R-53.4 (9.40)	R-43.4 (7.65)	0.023 (0.13)

Detail 8.1.22

Exterior Insulated 2x6 Wood Stud (16" o.c.) Wall with Interior Wood Furring Assembly & Brick Ties Supporting Brick Veneer – Clear Wall

Thermal Performance Indicators

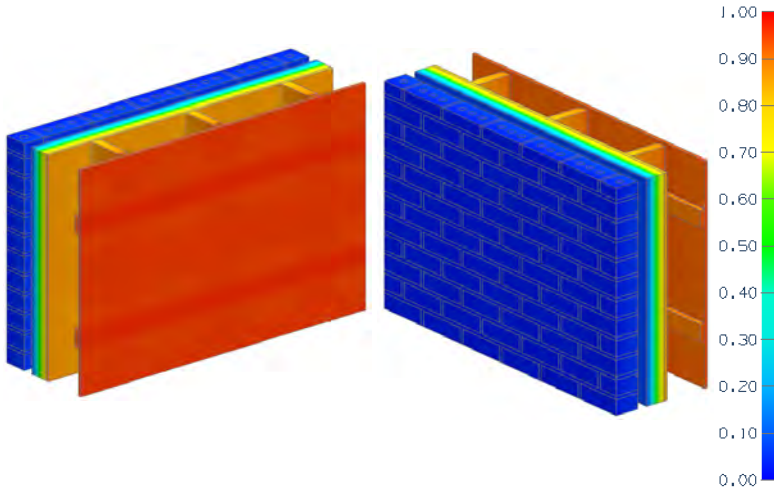

Assembly 1D (Nominal) R-Value	R_{1D}	R-4.0 (0.70 RSI) + exterior insulation
Transmittance / Resistance without Anomaly	$U_o,$ R_o	“clear wall” U- and R- value

View from Interior

View from Exterior

Nominal (1D) vs. Assembly Performance Indicators

Exterior Insulation 1D R-Value (RSI)	R_{1D} ft ² ·hr·°F / Btu (m ² K / W)	R_o ft ² ·hr·°F / Btu (m ² K / W)	U_o Btu/ft ² ·hr ·°F (W/m ² K)
R-10 (1.76)	R-14.0 (2.46)	R-13.0 (2.29)	0.077 (0.44)
R-15 (2.64)	R-19.0 (3.35)	R-16.6 (2.92)	0.060 (0.34)
R-20 (3.52)	R-24.0 (4.23)	R-19.8 (3.49)	0.050 (0.29)
R-25 (4.40)	R-29.0 (5.11)	R-22.8 (4.02)	0.044 (0.25)
R-30 (5.28)	R-34.0 (5.99)	R-25.6 (4.50)	0.039 (0.22)

Detail 8.1.23

Exterior and Interior Insulated 2x6 Wood Stud (16" o.c.) Wall with Interior Wood Furring Assembly & Brick Ties Supporting Brick Veneer – Clear Wall

Thermal Performance Indicators

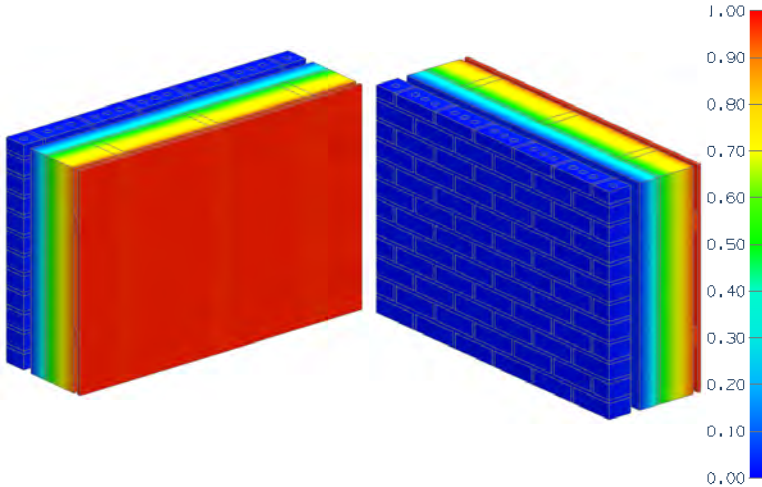

View from Interior

View from Exterior

Assembly 1D (Nominal) R-Value	R_{1D}	R-23.0 (4.05 RSI) + exterior insulation
Transmittance / Resistance without Anomaly	U_o, R_o	“clear wall” U- and R-value

Nominal (1D) vs. Assembly Performance Indicators

Exterior Insulation 1D R-Value (RSI)	R_{1D} ft ² ·hr·°F / Btu (m ² K / W)	R_o ft ² ·hr·°F / Btu (m ² K / W)	U_o Btu/ft ² ·hr ·°F (W/m ² K)
R-5 (0.88)	R-28.0 (4.93)	R-25.8 (4.54)	0.039 (0.22)
R-10 (1.76)	R-33.0 (5.81)	R-29.8 (5.26)	0.034 (0.19)
R-15 (2.64)	R-38.0 (6.69)	R-33.5 (5.91)	0.030 (0.17)
R-20 (3.52)	R-43.0 (7.57)	R-36.9 (6.50)	0.027 (0.15)
R-25 (4.40)	R-48.0 (8.45)	R-40.0 (7.05)	0.025 (0.14)
R-30 (5.28)	R-53.0 (9.33)	R-42.9 (7.56)	0.023 (0.13)

Detail 8.1.24

Interior Insulated Double Framed Wall 2x6 and 2x4 Wood Stud (16" o.c.) Wall Assembly with 1" Gap – Clear Wall

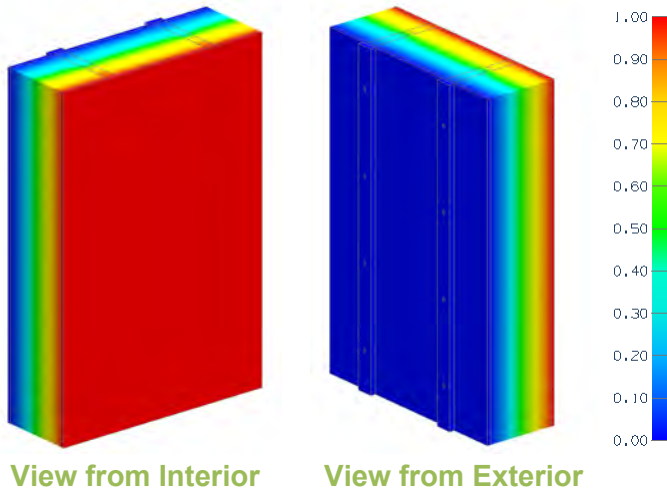

Thermal Performance Indicators

Assembly 1D (Nominal) R-Value	R_{1D}	R-2.5 (0.44 RSI) + exterior insulation
Transmittance / Resistance without Anomaly	U_o, R_o	"clear field" U- and R-value

Nominal (1D) vs. Assembly Performance Indicators

Insulation R/in	Fill Insulation 1D R-Value (RSI)	R_{1D} ft ² ·hr·°F / Btu (m ² K / W)	R_o ft ² ·hr·°F / Btu (m ² K / W)	U_o Btu/ft ² ·hr ·°F (W/m ² K)
3.5	R-35.0 (6.16)	R-37.5 (6.61)	R-34.5 (6.07)	0.029 (0.16)
4	R-40.0 (7.04)	R-42.5 (7.49)	R-38.3 (6.74)	0.026 (0.15)
5	R-50.0 (8.81)	R-52.5 (9.25)	R-45.6 (8.02)	0.022 (0.12)
6	R-60.0 (10.57)	R-62.5 (11.01)	R-52.5 (9.24)	0.019 (0.11)

Detail 8.1.25

Exterior and Interior Insulated 2x6 Wood Stud (16" o.c.) Wall Assembly with SOPREMA SOPRA-XPS 20 and ACS-S Thermal Clip Supporting Metal Cladding with R-19 Cellulose Insulation in Stud Cavity - Clear Wall

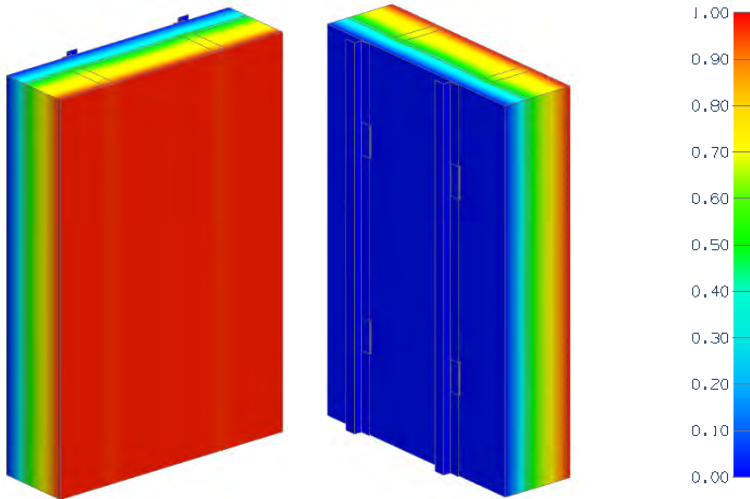

View from Interior View from Exterior

Thermal Performance Indicators

Assembly 1D (Nominal) R-Value	R_{1D}	R-21.5 (3.79 RSI) + exterior insulation
Transmittance / Resistance	U_o , R_o	"Clear wall" U- and R-value

Nominal (1D) vs. Assembly Performance Indicators

Exterior Insulation 1D R-value (RSI)	R_{1D} ft ² ·hr·°F / Btu (m ² K / W)	24" Vertical Spacing		36" Vertical Spacing		48" Vertical Spacing	
		R_o ft ² ·hr·°F / Btu (m ² K / W)	U_o Btu/ft ² ·hr·°F (W/m ² K)	R_o ft ² ·hr·°F / Btu (m ² K / W)	U_o Btu/ft ² ·hr·°F (W/m ² K)	R_o ft ² ·hr·°F / Btu (m ² K / W)	U_o Btu/ft ² ·hr·°F (W/m ² K)
R-5.0 (0.88)	R-26.5 (4.67)	R-24.5 (4.31)	0.041 (0.23)	R-24.5 (4.31)	0.041 (0.23)	R-24.5 (4.31)	0.041 (0.23)
R-7.5 (1.32)	R-29.0 (5.11)	R-26.8 (4.71)*	0.037 (0.21)*	R-26.9 (4.73)*	0.037 (0.21)*	R-26.9 (4.74)*	0.037 (0.21)*
R-10.0 (1.76)	R-31.5 (5.55)	R-29.1 (5.12)*	0.034 (0.20)*	R-29.2 (5.15)*	0.034 (0.19)*	R-29.3 (5.16)*	0.034 (0.19)*
R-15.0 (2.64)	R-36.5 (6.44)	R-33.6 (5.92)	0.030 (0.17)	R-33.9 (5.97)	0.029 (0.17)	R-34.1 (6.00)	0.029 (0.17)
R-20.0 (3.52)	R-41.5 (7.32)	R-38.0 (6.69)*	0.026 (0.15)*	R-38.5 (6.78)*	0.026 (0.15)*	R-38.8 (6.83)*	0.026 (0.15)*
R-25.0 (4.40)	R-46.5 (8.20)	R-42.3 (7.45)	0.024 (0.13)	R-43.0 (7.58)	0.023 (0.13)	R-43.4 (7.64)	0.023 (0.13)
R-30.0 (5.28)	R-51.5 (9.08)	R-46.6 (8.21)*	0.021 (0.12)*	R-47.5 (8.37)*	0.021 (0.12)*	R-48.0 (8.46)*	0.021 (0.12)*
R-35.0 (6.16)	R-56.5 (9.96)	R-50.8 (8.94)	0.020 (0.11)	R-52.0 (9.15)	0.019 (0.11)	R-52.6 (9.26)	0.019 (0.11)

*Indicates interpolated value

Detail 8.1.26

Exterior and Interior Insulated 2x6 Wood Stud (24" o.c.) Wall Assembly with SOPREMA SOPRA-XPS 20 and ACS-S Thermal Clip Supporting Metal Cladding with R-19 Cellulose Insulation in Stud Cavity - Clear Wall

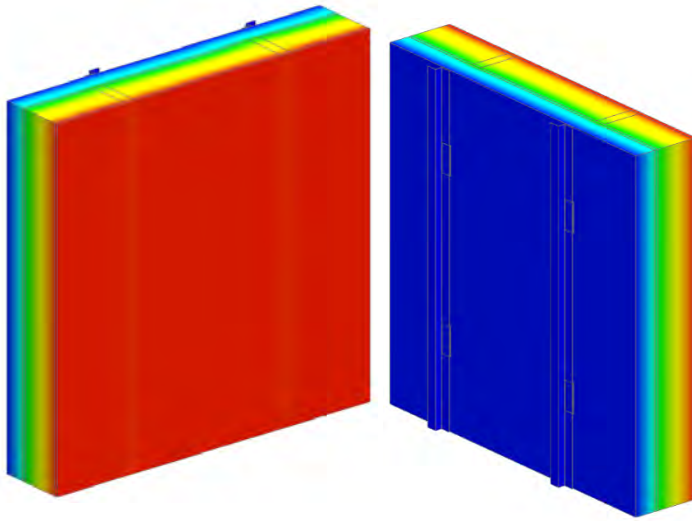

View from Interior

View from Exterior

Thermal Performance Indicators

Assembly 1D (Nominal) R-Value	R_{1D}	R-21.5 (3.79 RSI) + exterior insulation
Transmittance / Resistance	U_o , R_o	"Clear wall" U- and R-value

Nominal (1D) vs. Assembly Performance Indicators

Exterior Insulation 1D R-value (RSI)	R_{1D} ft ² ·hr·°F / Btu (m ² K / W)	24" Vertical Spacing		36" Vertical Spacing		48" Vertical Spacing	
		R_o ft ² ·hr·°F / Btu (m ² K / W)	U_o Btu/ft ² ·hr·°F (W/m ² K)	R_o ft ² ·hr·°F / Btu (m ² K / W)	U_o Btu/ft ² ·hr·°F (W/m ² K)	R_o ft ² ·hr·°F / Btu (m ² K / W)	U_o Btu/ft ² ·hr·°F (W/m ² K)
R-5.0 (0.88)	R-26.5 (4.67)	R-25.2 (4.43)	0.040 (0.23)	R-25.2 (4.43)	0.040 (0.23)	R-25.3 (4.46)	0.040 (0.22)
R-7.5 (1.32)	R-29.0 (5.11)	R-27.5 (4.85)*	0.036 (0.21)*	R-27.6 (4.86)*	0.036 (0.21)*	R-27.7 (4.89)*	0.036 (0.20)*
R-10.0 (1.76)	R-31.5 (5.55)	R-29.9 (5.26)*	0.033 (0.19)*	R-30.0 (5.28)*	0.033 (0.19)*	R-30.2 (5.31)*	0.033 (0.19)*
R-15.0 (2.64)	R-36.5 (6.44)	R-34.6 (6.09)	0.029 (0.16)	R-34.8 (6.13)	0.029 (0.16)	R-35.0 (6.17)	0.029 (0.16)
R-20.0 (3.52)	R-41.5 (7.32)	R-39.1 (6.89)*	0.026 (0.15)*	R-39.5 (6.96)*	0.025 (0.14)*	R-39.8 (7.01)*	0.025 (0.14)*
R-25.0 (4.40)	R-46.5 (8.20)	R-43.7 (7.69)	0.023 (0.13)	R-44.2 (7.78)	0.023 (0.13)	R-44.6 (7.85)	0.022 (0.13)
R-30.0 (5.28)	R-51.5 (9.08)	R-48.2 (8.48)*	0.021 (0.12)*	R-48.8 (8.60)*	0.020 (0.12)*	R-49.3 (8.68)*	0.020 (0.12)*
R-35.0 (6.16)	R-56.5 (9.96)	R-52.6 (9.26)	0.019 (0.11)	R-53.4 (9.41)	0.019 (0.11)	R-54.0 (9.51)	0.019 (0.11)

*Indicates interpolated value

Detail 8.1.27

Exterior and Interior Insulated 2x6 Wood Stud (16" o.c.) Wall Assembly with SOPREMA SOPRA-SPF 202 and ACS-S Thermal Clip Supporting Metal Cladding with R-19 Cellulose Insulation in Stud Cavity - Clear Wall

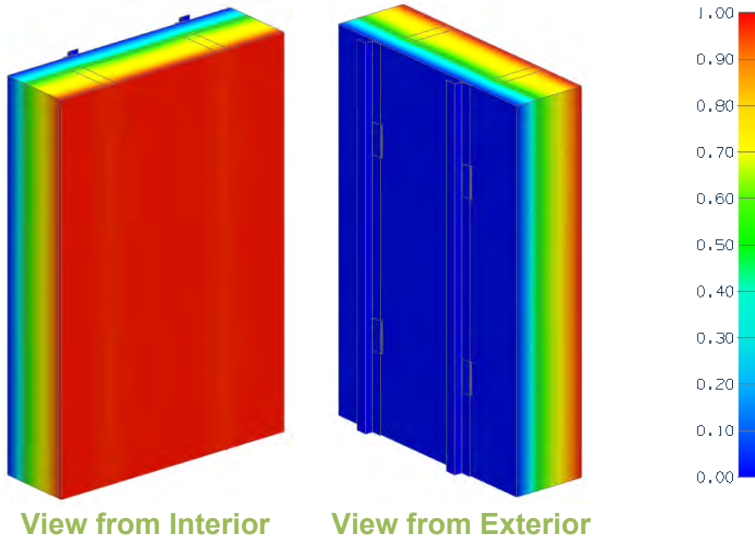

Thermal Performance Indicators

Assembly 1D (Nominal) R-Value	R_{1D}	R-21.5 (3.79 RSI) + exterior insulation
Transmittance / Resistance	U_o / R_o	"Clear wall" U- and R-value

Nominal (1D) vs. Assembly Performance Indicators

Exterior Insulation 1D R-value (RSI)	R_{1D} ft ² ·hr·°F / Btu (m ² K / W)	24" Vertical Spacing		36" Vertical Spacing		48" Vertical Spacing	
		R_o ft ² ·hr·°F / Btu (m ² K / W)	U_o Btu/ft ² ·hr ·°F (W/m ² K)	R_o ft ² ·hr·°F / Btu (m ² K / W)	U_o Btu/ft ² ·hr ·°F (W/m ² K)	R_o ft ² ·hr·°F / Btu (m ² K / W)	U_o Btu/ft ² ·hr ·°F (W/m ² K)
R-6.2 (1.09)	R-27.7 (4.89)	R-25.6 (4.50)	0.039 (0.22)	R-25.6 (4.51)	0.039 (0.22)	R-25.6 (4.51)	0.039 (0.22)
R-12.4 (2.18)	R-33.9 (5.98)	R-31.2 (5.49)*	0.032 (0.18)*	R-31.4 (5.53)*	0.032 (0.18)*	R-31.5 (5.55)*	0.032 (0.18)*
R-18.6 (3.28)	R-40.1 (7.07)	R-36.7 (6.47)	0.027 (0.15)	R-37.1 (6.54)	0.027 (0.15)	R-37.4 (6.58)	0.027 (0.15)
R-24.8 (4.37)	R-46.3 (8.16)	R-42.0 (7.40)*	0.024 (0.14)*	R-42.7 (7.53)*	0.023 (0.13)*	R-43.1 (7.59)*	0.023 (0.13)*
R-31.0 (5.46)	R-52.5 (9.25)	R-47.2 (8.31)	0.021 (0.12)	R-48.2 (8.49)	0.021 (0.12)	R-48.8 (8.59)	0.021 (0.12)
R-37.2 (6.55)	R-58.7 (10.35)	R-52.4 (9.22)*	0.019 (0.11)*	R-53.7 (9.46)*	0.019 (0.11)*	R-54.4 (9.59)*	0.018 (0.10)*
R-43.4 (7.64)	R-64.9 (11.44)	R-57.4 (10.11)	0.017 (0.10)	R-59.1 (10.41)	0.017 (0.10)	R-60.0 (10.56)	0.017 (0.09)

*Indicates interpolated value

Detail 8.1.28

Exterior and Interior Insulated 2x6 Wood Stud (24" o.c.) Wall Assembly with SOPREMA SOPRA-SPF 202 and ACS-S Thermal Clip Supporting Metal Cladding with R-19 Cellulose Insulation in Stud Cavity - Clear Wall

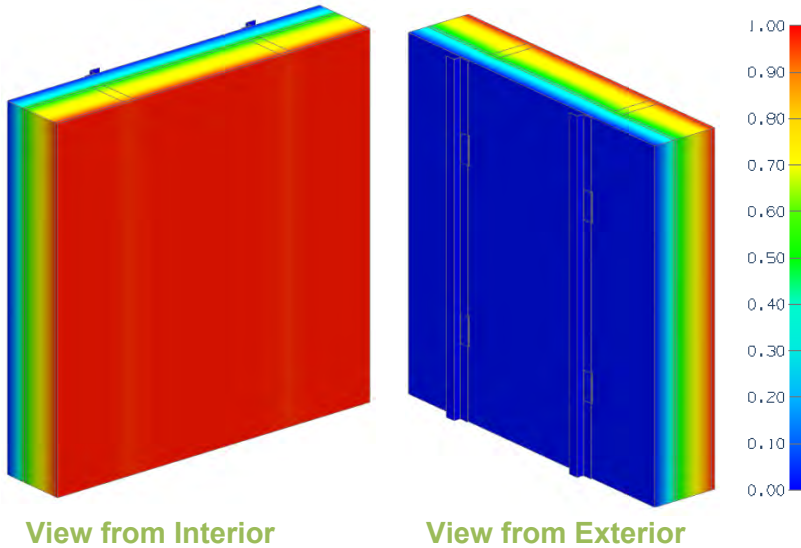

Thermal Performance Indicators

Assembly 1D (Nominal) R-Value	R_{1D}	R-21.5 (3.79 RSI) + exterior insulation
Transmittance / Resistance	U_o / R_o	"Clear wall" U- and R-value

Nominal (1D) vs. Assembly Performance Indicators

Exterior Insulation 1D R-value (RSI)	R_{1D} ft ² ·hr·°F / Btu (m ² K / W)	24" Vertical Spacing		36" Vertical Spacing		48" Vertical Spacing	
		R_o ft ² ·hr·°F / Btu (m ² K / W)	U_o Btu/ft ² ·hr ·°F (W/m ² K)	R_o ft ² ·hr·°F / Btu (m ² K / W)	U_o Btu/ft ² ·hr ·°F (W/m ² K)	R_o ft ² ·hr·°F / Btu (m ² K / W)	U_o Btu/ft ² ·hr ·°F (W/m ² K)
R-6.2 (1.09)	R-27.7 (4.89)	R-26.3 (4.63)	0.038 (0.22)	R-26.3 (4.63)	0.038 (0.22)	R-26.4 (4.65)	0.038 (0.21)
R-12.4 (2.18)	R-33.9 (5.98)	R-32.0 (5.64)*	0.031 (0.18)*	R-32.2 (5.68)*	0.031 (0.18)*	R-32.4 (5.71)*	0.031 (0.18)*
R-18.6 (3.28)	R-40.1 (7.07)	R-37.7 (6.64)	0.027 (0.15)	R-38.1 (6.71)	0.026 (0.15)	R-38.4 (6.76)	0.026 (0.15)
R-24.8 (4.37)	R-46.3 (8.16)	R-43.0 (7.58)*	0.023 (0.13)*	R-43.9 (7.73)*	0.023 (0.13)*	R-44.3 (7.80)*	0.023 (0.13)*
R-31.0 (5.46)	R-52.5 (9.25)	R-48.1 (8.48)	0.021 (0.12)	R-49.6 (8.74)	0.020 (0.11)	R-50.1 (8.83)	0.020 (0.11)
R-37.2 (6.55)	R-58.7 (10.35)	R-53.3 (9.39)*	0.019 (0.11)*	R-55.3 (9.74)*	0.018 (0.10)*	R-55.9 (9.85)*	0.018 (0.10)*
R-43.4 (7.64)	R-64.9 (11.44)	R-58.2 (10.26)	0.017 (0.10)	R-60.9 (10.73)	0.016 (0.09)	R-61.7 (10.86)	0.016 (0.09)

*Indicates interpolated value

Detail 8.1.29

Exterior and Interior Insulated 2x6 Wood Stud (16" o.c.) Wall Assembly with SOPREMA SOPRA-ISO V PLUS and ACS-S Thermal Clip Supporting Metal Cladding with R-19 Cellulose Insulation in Stud Cavity - Clear Wall

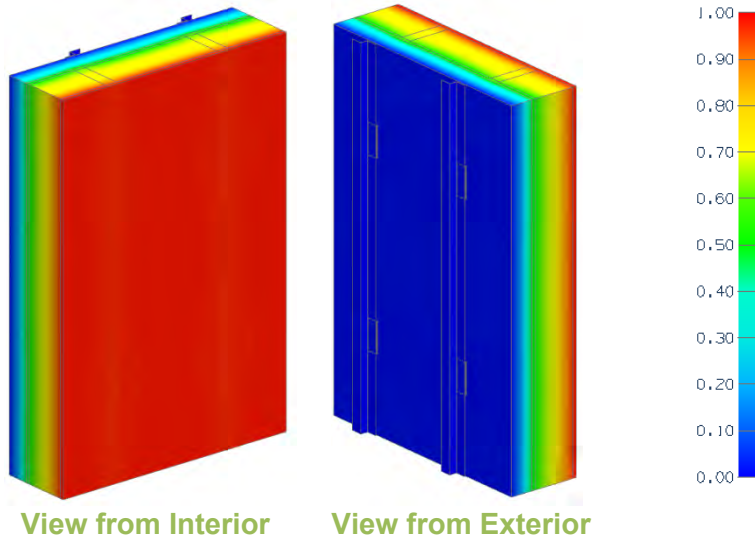

Thermal Performance Indicators

Assembly 1D (Nominal) R-Value	R_{1D}	R-21.5 (3.79 RSI) + exterior insulation
Transmittance / Resistance	U_o , R_o	"Clear wall" U- and R-value

Nominal (1D) vs. Assembly Performance Indicators

Exterior Insulation 1D R-value (RSI)	R_{1D} ft ² ·hr·°F / Btu (m ² K / W)	24" Vertical Spacing		36" Vertical Spacing		48" Vertical Spacing	
		R_o ft ² ·hr·°F / Btu (m ² K / W)	U_o Btu/ft ² ·hr ·°F (W/m ² K)	R_o ft ² ·hr·°F / Btu (m ² K / W)	U_o Btu/ft ² ·hr ·°F (W/m ² K)	R_o ft ² ·hr·°F / Btu (m ² K / W)	U_o Btu/ft ² ·hr ·°F (W/m ² K)
R-6.0 (1.06)	R-27.5 (4.85)	R-25.4 (4.48)	0.039 (0.22)	R-25.5 (4.48)	0.039 (0.22)	R-25.5 (4.49)	0.039 (0.22)
R-9.0 (1.59)	R-30.5 (5.38)	R-28.2 (4.96)*	0.035 (0.20)*	R-28.3 (4.98)*	0.035 (0.20)*	R-28.4 (4.99)*	0.035 (0.20)*
R-12.0 (2.11)	R-33.5 (5.91)	R-30.9 (5.44)*	0.032 (0.18)*	R-31.1 (5.48)*	0.032 (0.18)*	R-31.2 (5.50)*	0.032 (0.18)*
R-15.0 (2.64)	R-36.5 (6.44)	R-33.6 (5.92)*	0.030 (0.17)*	R-33.9 (5.97)*	0.030 (0.17)*	R-34.1 (6.00)*	0.029 (0.17)*
R-18.0 (3.17)	R-39.5 (6.96)	R-36.3 (6.39)	0.028 (0.16)	R-36.7 (6.46)	0.027 (0.15)	R-36.9 (6.50)	0.027 (0.15)
R-21.0 (3.70)	R-42.5 (7.49)	R-38.9 (6.85)*	0.026 (0.15)*	R-39.4 (6.94)*	0.025 (0.14)*	R-39.7 (6.99)*	0.025 (0.14)*
R-24.0 (4.23)	R-45.5 (8.02)	R-41.5 (7.30)*	0.024 (0.14)*	R-42.1 (7.42)*	0.024 (0.13)*	R-42.5 (7.48)*	0.024 (0.13)*
R-27.0 (4.76)	R-48.5 (8.55)	R-44.0 (7.76)*	0.023 (0.13)*	R-44.8 (7.89)*	0.022 (0.13)*	R-45.2 (7.97)*	0.022 (0.13)*
R-30.0 (5.28)	R-51.5 (9.08)	R-46.5 (8.20)	0.021 (0.12)	R-47.5 (8.36)	0.021 (0.12)	R-48.0 (8.45)	0.021 (0.12)
R-33.0 (5.81)	R-54.5 (9.61)	R-49.1 (8.64)*	0.020 (0.12)*	R-50.2 (8.83)*	0.020 (0.11)*	R-50.7 (8.94)*	0.020 (0.11)*
R-36.0 (6.34)	R-57.5 (10.13)	R-51.6 (9.08)*	0.019 (0.11)*	R-52.8 (9.30)*	0.019 (0.11)*	R-53.5 (9.42)*	0.019 (0.11)*
R-39.0 (6.87)	R-60.5 (10.66)	R-54.0 (9.51)*	0.019 (0.11)*	R-55.4 (9.76)*	0.018 (0.10)*	R-56.2 (9.89)*	0.018 (0.10)*
R-42.0 (7.40)	R-63.5 (11.19)	R-56.4 (9.94)	0.018 (0.10)	R-58.0 (10.22)	0.017 (0.10)	R-58.9 (10.37)	0.017 (0.10)

*Indicates interpolated value

Detail 8.1.30

Exterior and Interior Insulated 2x6 Wood Stud (24" o.c.) Wall Assembly with SOPREMA SOPRA-ISO V PLUS and ACS-S Thermal Clip Supporting Metal Cladding with R-19 Cellulose Insulation in Stud Cavity - Clear Wall

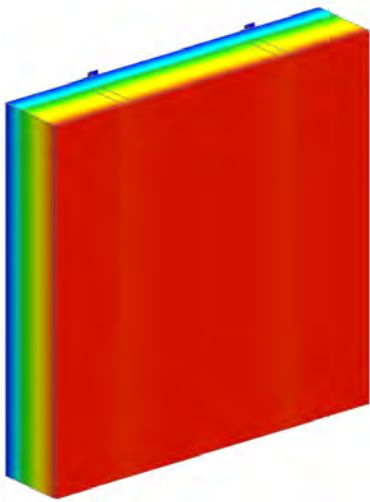

View from Interior

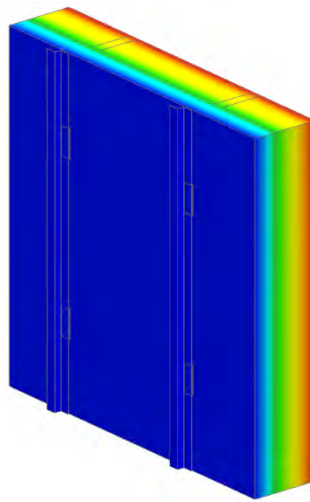

View from Exterior

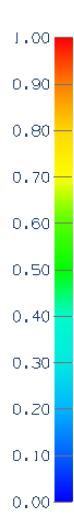

Thermal Performance Indicators

Assembly 1D (Nominal) R-Value	R_{1D}	R-21.5 (3.79 RSI) + exterior insulation
Transmittance / Resistance	U_o , R_o	"Clear wall" U- and R-value

Nominal (1D) vs. Assembly Performance Indicators

Exterior Insulation 1D R-value (RSI)	R_{1D} ft ² ·hr·°F / Btu (m ² K / W)	24" Vertical Spacing		36" Vertical Spacing		48" Vertical Spacing	
		R_o ft ² ·hr·°F / Btu (m ² K / W)	U_o Btu/ft ² ·hr ·°F (W/m ² K)	R_o ft ² ·hr·°F / Btu (m ² K / W)	U_o Btu/ft ² ·hr ·°F (W/m ² K)	R_o ft ² ·hr·°F / Btu (m ² K / W)	U_o Btu/ft ² ·hr ·°F (W/m ² K)
R-6.0 (1.06)	R-27.5 (4.85)	R-26.1 (4.60)	0.038 (0.22)	R-26.2 (4.61)	0.038 (0.22)	R-26.3 (4.63)	0.038 (0.22)
R-9.0 (1.59)	R-30.5 (5.38)	R-28.9 (5.10)*	0.035 (0.20)*	R-29.0 (5.12)*	0.034 (0.20)*	R-29.2 (5.14)*	0.034 (0.19)*
R-12.0 (2.11)	R-33.5 (5.91)	R-31.7 (5.58)*	0.032 (0.18)*	R-31.9 (5.62)*	0.031 (0.18)*	R-32.1 (5.66)*	0.031 (0.18)*
R-15.0 (2.64)	R-36.5 (6.44)	R-34.4 (6.06)*	0.029 (0.17)*	R-34.8 (6.12)*	0.029 (0.16)*	R-35.0 (6.16)*	0.029 (0.16)*
R-18.0 (3.17)	R-39.5 (6.96)	R-37.2 (6.55)	0.027 (0.15)	R-37.6 (6.63)	0.027 (0.15)	R-37.9 (6.67)	0.026 (0.15)
R-21.0 (3.70)	R-42.5 (7.49)	R-39.7 (7.00)*	0.025 (0.14)*	R-40.4 (7.12)*	0.025 (0.14)*	R-40.7 (7.18)*	0.025 (0.14)*
R-24.0 (4.23)	R-45.5 (8.02)	R-42.3 (7.45)*	0.024 (0.13)*	R-43.3 (7.62)*	0.023 (0.13)*	R-43.6 (7.68)*	0.023 (0.13)*
R-27.0 (4.76)	R-48.5 (8.55)	R-44.9 (7.90)*	0.022 (0.13)*	R-46.0 (8.11)*	0.022 (0.12)*	R-46.4 (8.18)*	0.022 (0.12)*
R-30.0 (5.28)	R-51.5 (9.08)	R-47.3 (8.33)	0.021 (0.12)	R-48.8 (8.60)	0.020 (0.12)	R-49.3 (8.68)	0.020 (0.12)
R-33.0 (5.81)	R-54.5 (9.61)	R-49.9 (8.79)*	0.020 (0.11)*	R-51.6 (9.09)*	0.019 (0.11)*	R-52.1 (9.18)*	0.019 (0.11)*
R-36.0 (6.34)	R-57.5 (10.13)	R-52.4 (9.22)*	0.019 (0.11)*	R-54.3 (9.57)*	0.018 (0.10)*	R-54.9 (9.67)*	0.018 (0.10)*
R-39.0 (6.87)	R-60.5 (10.66)	R-54.8 (9.65)*	0.018 (0.10)*	R-57.1 (10.05)*	0.018 (0.10)*	R-57.7 (10.16)*	0.017 (0.10)*
R-42.0 (7.40)	R-63.5 (11.19)	R-57.2 (10.07)	0.017 (0.10)	R-59.8 (10.53)	0.017 (0.09)	R-60.5 (10.65)	0.017 (0.09)

*Indicates interpolated value

Detail 8.1.31

Exterior and Interior Insulated 2x6 Wood Stud (16" o.c.) Wall Assembly with Mineral Wool and ACS-S Thermal Clip Supporting Metal Cladding with R-19 Cellulose Insulation in Stud Cavity - Clear Wall

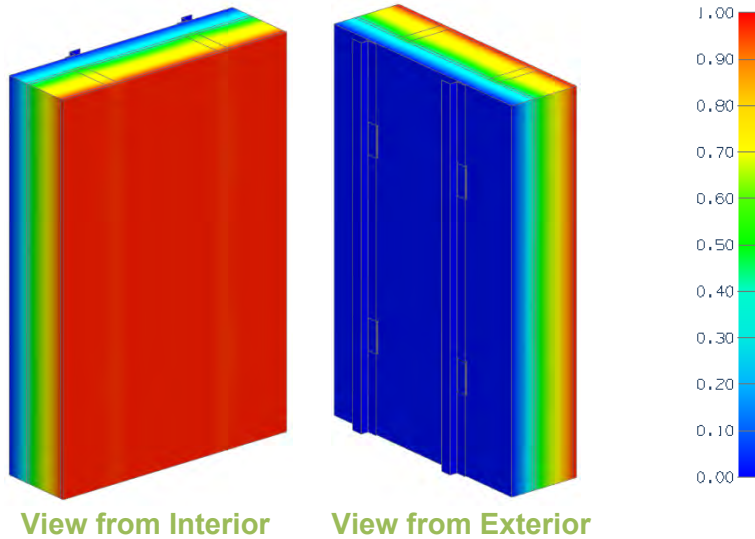

Thermal Performance Indicators

Assembly 1D (Nominal) R-Value	R_{1D}	R-21.5 (3.79 RSI) + exterior insulation
Transmittance / Resistance	U_o , R_o	"Clear wall" U- and R-value

Nominal (1D) vs. Assembly Performance Indicators

Exterior Insulation 1D R-value (RSI)	R_{1D} ft ² ·hr·°F / Btu (m ² K / W)	24" Vertical Spacing		36" Vertical Spacing		48" Vertical Spacing	
		R_o ft ² ·hr·°F / Btu (m ² K / W)	U_o Btu/ft ² ·hr ·°F (W/m ² K)	R_o ft ² ·hr·°F / Btu (m ² K / W)	U_o Btu/ft ² ·hr ·°F (W/m ² K)	R_o ft ² ·hr·°F / Btu (m ² K / W)	U_o Btu/ft ² ·hr ·°F (W/m ² K)
R-4.3 (0.76)	R-25.8 (4.55)	R-23.8 (4.19)	0.042 (0.24)	R-23.8 (4.19)	0.042 (0.24)	R-23.8 (4.19)	0.042 (0.24)
R-8.6 (1.51)	R-30.1 (5.31)	R-27.8 (4.89)*	0.036 (0.20)*	R-27.9 (4.91)*	0.036 (0.20)*	R-27.9 (4.92)*	0.036 (0.20)*
R-12.9 (2.27)	R-34.4 (6.07)	R-31.7 (5.58)	0.032 (0.18)	R-31.9 (5.63)	0.031 (0.18)	R-32.1 (5.65)	0.031 (0.18)
R-17.2 (3.03)	R-38.7 (6.82)	R-35.5 (6.26)*	0.028 (0.16)*	R-35.9 (6.33)*	0.028 (0.16)*	R-36.1 (6.36)*	0.028 (0.16)*
R-21.5 (3.79)	R-43.0 (7.58)	R-39.3 (6.92)	0.025 (0.14)	R-39.9 (7.02)	0.025 (0.14)	R-40.2 (7.07)	0.025 (0.14)
R-25.8 (4.54)	R-47.3 (8.34)	R-43.1 (7.59)*	0.023 (0.13)*	R-43.8 (7.72)*	0.023 (0.13)*	R-44.2 (7.78)*	0.023 (0.13)*
R-30.1 (5.30)	R-51.6 (9.09)	R-46.8 (8.25)*	0.021 (0.12)*	R-47.7 (8.40)*	0.021 (0.12)*	R-48.2 (8.49)*	0.021 (0.12)*
R-34.4 (6.06)	R-55.9 (9.85)	R-50.5 (8.90)	0.020 (0.11)	R-51.6 (9.09)	0.019 (0.11)	R-52.1 (9.18)	0.019 (0.11)

*Indicates interpolated value

Detail 8.1.32

Exterior and Interior Insulated 2x6 Wood Stud (24" o.c.) Wall Assembly with Mineral Wool and ACS-S Thermal Clip Supporting Metal Cladding with R-19 Cellulose Insulation in Stud Cavity - Clear Wall

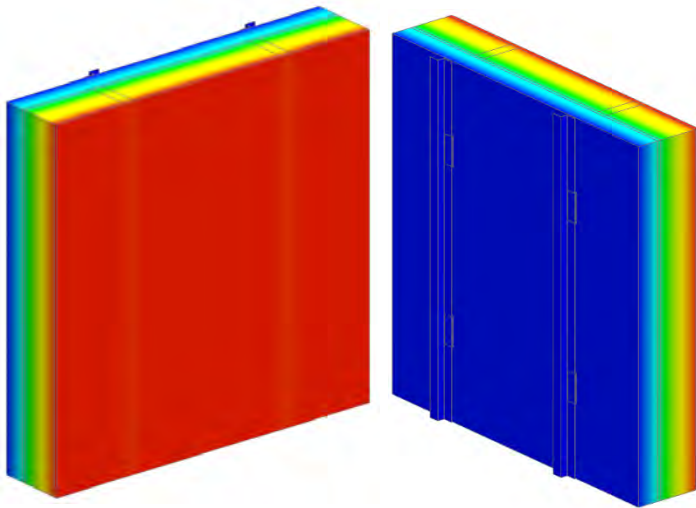

View from Interior

View from Exterior

Thermal Performance Indicators

Assembly 1D (Nominal) R-Value	R_{1D}	R-21.5 (3.79 RSI) + exterior insulation
Transmittance / Resistance	U_o / R_o	"Clear wall" U- and R-value

Nominal (1D) vs. Assembly Performance Indicators

Exterior Insulation 1D R-value (RSI)	R_{1D} ft ² ·hr·°F / Btu (m ² K / W)	24" Vertical Spacing		36" Vertical Spacing		48" Vertical Spacing	
		R_o ft ² ·hr·°F / Btu (m ² K / W)	U_o Btu/ft ² ·hr ·°F (W/m ² K)	R_o ft ² ·hr·°F / Btu (m ² K / W)	U_o Btu/ft ² ·hr ·°F (W/m ² K)	R_o ft ² ·hr·°F / Btu (m ² K / W)	U_o Btu/ft ² ·hr ·°F (W/m ² K)
R-4.3 (0.76)	R-25.8 (4.55)	R-24.5 (4.31)	0.041 (0.23)	R-24.5 (4.31)	0.041 (0.23)	R-24.6 (4.33)	0.041 (0.23)
R-8.6 (1.51)	R-30.1 (5.31)	R-28.5 (5.02)*	0.035 (0.20)*	R-28.6 (5.04)*	0.035 (0.20)*	R-28.8 (5.07)*	0.035 (0.20)*
R-12.9 (2.27)	R-34.4 (6.07)	R-32.5 (5.72)	0.031 (0.17)	R-32.8 (5.77)	0.031 (0.17)	R-33.0 (5.81)	0.030 (0.17)
R-17.2 (3.03)	R-38.7 (6.82)	R-36.2 (6.38)*	0.028 (0.16)*	R-36.9 (6.49)*	0.027 (0.15)*	R-37.1 (6.54)*	0.027 (0.15)*
R-21.5 (3.79)	R-43.0 (7.58)	R-40.0 (7.04)	0.025 (0.14)	R-40.9 (7.21)	0.024 (0.14)	R-41.2 (7.26)	0.024 (0.14)
R-25.8 (4.54)	R-47.3 (8.34)	R-43.7 (7.70)*	0.023 (0.13)*	R-45.0 (7.92)*	0.022 (0.13)*	R-45.3 (7.99)*	0.022 (0.13)*
R-30.1 (5.30)	R-51.6 (9.09)	R-47.3 (8.34)*	0.021 (0.12)*	R-49.0 (8.63)*	0.020 (0.12)*	R-49.4 (8.71)*	0.020 (0.11)*
R-34.4 (6.06)	R-55.9 (9.85)	R-50.9 (8.97)	0.020 (0.11)	R-53.0 (9.33)	0.019 (0.11)	R-53.5 (9.42)	0.019 (0.11)

*Indicates interpolated value

Detail 8.1.33

Exterior and Interior Insulated 2x6 Wood Stud (16" o.c.) Wall Assembly with Protected SOPREMA SOPRA-ISO V PLUS and ACS-S Thermal Clip Supporting Metal Cladding with R-19 Cellulose Insulation in Stud Cavity - Clear Wall

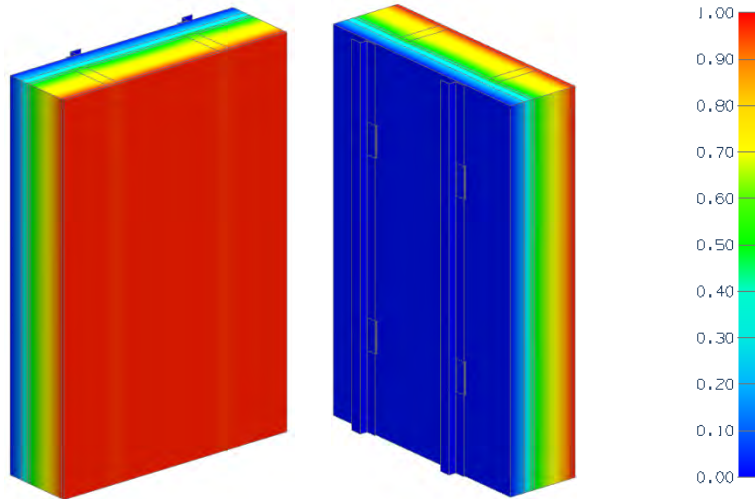

View from Interior View from Exterior

Thermal Performance Indicators

Assembly 1D (Nominal) R-Value	R_{1D}	R-21.5 (3.79 RSI) + exterior insulation
Transmittance / Resistance	U_o / R_o	"Clear wall" U- and R-value

Nominal (1D) vs. Assembly Performance Indicators

Exterior Insulation 1D R-value (RSI)	R_{1D} ft ² ·hr·°F / Btu (m ² K / W)	24" Vertical Spacing		36" Vertical Spacing		48" Vertical Spacing	
		R_o ft ² ·hr·°F / Btu (m ² K / W)	U_o Btu/ft ² ·hr ·°F (W/m ² K)	R_o ft ² ·hr·°F / Btu (m ² K / W)	U_o Btu/ft ² ·hr ·°F (W/m ² K)	R_o ft ² ·hr·°F / Btu (m ² K / W)	U_o Btu/ft ² ·hr ·°F (W/m ² K)
R-14.6 (2.57)	R-36.1 (6.36)	R-33.4 (5.88)	0.030 (0.17)	R-33.7 (5.93)	0.030 (0.17)	R-33.8 (5.96)	0.030 (0.17)
R-17.6 (3.10)	R-39.1 (6.89)	R-36.1 (6.35)*	0.028 (0.16)*	R-36.4 (6.42)*	0.027 (0.16)*	R-36.6 (6.45)*	0.027 (0.16)*
R-20.6 (3.63)	R-42.1 (7.42)	R-38.7 (6.82)	0.026 (0.15)	R-39.2 (6.90)	0.026 (0.14)	R-39.4 (6.94)	0.025 (0.14)
R-23.6 (4.16)	R-45.1 (7.95)	R-41.3 (7.27)*	0.024 (0.14)*	R-41.9 (7.38)*	0.024 (0.14)*	R-42.2 (7.43)*	0.024 (0.13)*
R-26.6 (4.68)	R-48.1 (8.48)	R-43.8 (7.72)	0.023 (0.13)	R-44.6 (7.85)	0.022 (0.13)	R-45.0 (7.92)	0.022 (0.13)
R-29.6 (5.21)	R-51.1 (9.01)	R-46.4 (8.17)*	0.022 (0.12)*	R-47.3 (8.33)*	0.021 (0.12)*	R-47.7 (8.41)*	0.021 (0.12)*
R-32.6 (5.74)	R-54.1 (9.54)	R-48.9 (8.61)*	0.020 (0.12)*	R-49.9 (8.80)*	0.020 (0.11)*	R-50.5 (8.89)*	0.020 (0.11)*
R-35.6 (6.27)	R-57.1 (10.06)	R-51.4 (9.05)*	0.019 (0.11)*	R-52.6 (9.26)*	0.019 (0.11)*	R-53.2 (9.37)*	0.019 (0.11)*
R-38.6 (6.80)	R-60.1 (10.59)	R-53.9 (9.49)	0.019 (0.11)	R-55.2 (9.73)	0.018 (0.10)	R-55.9 (9.85)	0.018 (0.10)

*Indicates interpolated value

Detail 8.1.34

Exterior and Interior Insulated 2x6 Wood Stud (24" o.c.) Wall Assembly with Protected SOPREMA SOPRA-ISO V PLUS and ACS-S Thermal Clip Supporting Metal Cladding with R-19 Cellulose Insulation in Stud Cavity - Clear Wall

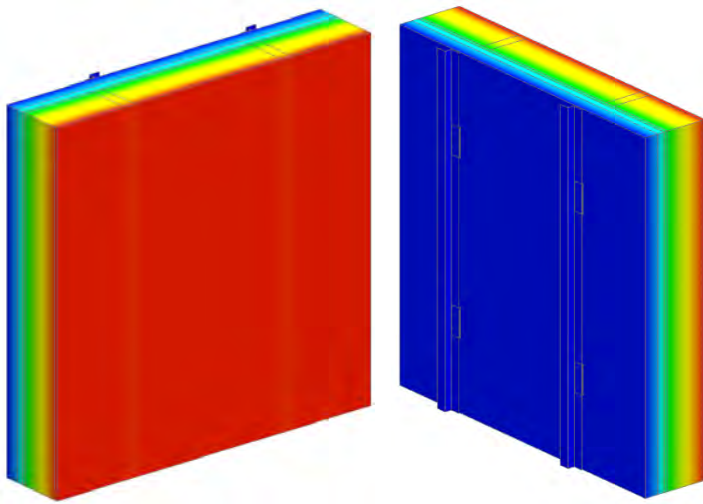

View from Interior

View from Exterior

Thermal Performance Indicators

Assembly 1D (Nominal) R-Value	R_{1D}	R-21.5 (3.79 RSI) + exterior insulation
Transmittance / Resistance	U_o , R_o	"Clear wall" U- and R-value

Nominal (1D) vs. Assembly Performance Indicators

Exterior Insulation 1D R-value (RSI)	R_{1D} ft ² ·hr·°F / Btu (m ² K / W)	24" Vertical Spacing		36" Vertical Spacing		48" Vertical Spacing	
		R_o ft ² ·hr·°F / Btu (m ² K / W)	U_o Btu/ft ² ·hr ·°F (W/m ² K)	R_o ft ² ·hr·°F / Btu (m ² K / W)	U_o Btu/ft ² ·hr ·°F (W/m ² K)	R_o ft ² ·hr·°F / Btu (m ² K / W)	U_o Btu/ft ² ·hr ·°F (W/m ² K)
R-14.6 (2.57)	R-36.1 (6.36)	R-34.1 (6.01)	0.029 (0.17)	R-34.5 (6.08)	0.029 (0.16)	R-34.7 (6.12)	0.029 (0.16)
R-17.6 (3.10)	R-39.1 (6.89)	R-37.0 (6.51)*	0.027 (0.15)*	R-37.3 (6.58)*	0.027 (0.15)*	R-37.6 (6.62)*	0.027 (0.15)*
R-20.6 (3.63)	R-42.1 (7.42)	R-39.8 (7.01)	0.025 (0.14)	R-40.2 (7.07)	0.025 (0.14)	R-40.5 (7.13)	0.025 (0.14)
R-23.6 (4.16)	R-45.1 (7.95)	R-42.5 (7.49)*	0.024 (0.13)*	R-43.0 (7.57)*	0.023 (0.13)*	R-43.3 (7.63)*	0.023 (0.13)*
R-26.6 (4.68)	R-48.1 (8.48)	R-45.2 (7.97)	0.022 (0.13)	R-45.8 (8.06)	0.022 (0.12)	R-46.1 (8.13)	0.022 (0.12)
R-29.6 (5.21)	R-51.1 (9.01)	R-48.0 (8.45)*	0.021 (0.12)*	R-48.5 (8.55)*	0.021 (0.12)*	R-49.0 (8.63)*	0.020 (0.12)*
R-32.6 (5.74)	R-54.1 (9.54)	R-50.6 (8.92)*	0.020 (0.11)*	R-51.3 (9.04)*	0.019 (0.11)*	R-51.8 (9.13)*	0.019 (0.11)*
R-35.6 (6.27)	R-57.1 (10.06)	R-53.3 (9.38)*	0.019 (0.11)*	R-54.1 (9.52)*	0.018 (0.11)*	R-54.6 (9.62)*	0.018 (0.10)*
R-38.6 (6.80)	R-60.1 (10.59)	R-55.9 (9.84)	0.018 (0.10)	R-56.8 (10.01)	0.018 (0.10)	R-57.5 (10.12)	0.017 (0.10)

*Indicates interpolated value

Detail 8.1.35

Exterior and Interior Insulated 2x4 Wood Stud (16" o.c.) Wall Assembly with Protected SOPREMA SOPRA-ISO V PLUS and ACS-S Thermal Clip Supporting Metal Cladding with R-13 Cellulose Insulation in Stud Cavity - Clear Wall

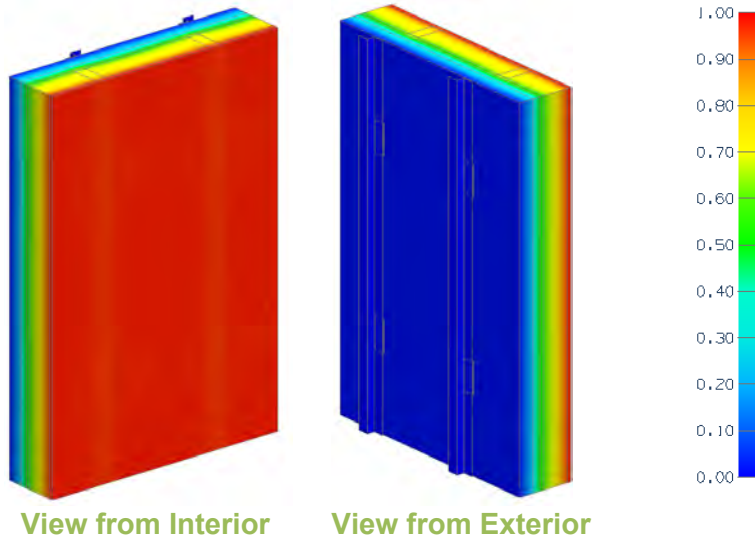

Thermal Performance Indicators

Assembly 1D (Nominal) R-Value	R_{1D}	R-15.5 (2.74 RSI) + exterior insulation
Transmittance / Resistance	U_o / R_o	"Clear wall" U- and R-value

Nominal (1D) vs. Assembly Performance Indicators

Exterior Insulation 1D R-value (RSI)	R_{1D} ft ² ·hr·°F / Btu (m ² K / W)	24" Vertical Spacing		36" Vertical Spacing		48" Vertical Spacing	
		R_o ft ² ·hr·°F / Btu (m ² K / W)	U_o Btu/ft ² ·hr ·°F (W/m ² K)	R_o ft ² ·hr·°F / Btu (m ² K / W)	U_o Btu/ft ² ·hr ·°F (W/m ² K)	R_o ft ² ·hr·°F / Btu (m ² K / W)	U_o Btu/ft ² ·hr ·°F (W/m ² K)
R-14.6 (2.57)	R-30.1 (5.31)	R-28.0 (4.94)	0.036 (0.20)	R-28.3 (4.99)	0.035 (0.20)	R-28.5 (5.01)	0.035 (0.20)
R-17.6 (3.10)	R-39.1 (6.89)	R-30.7 (5.41)*	0.033 (0.18)*	R-31.1 (5.47)*	0.032 (0.18)*	R-31.3 (5.51)*	0.032 (0.18)*
R-20.6 (3.63)	R-36.1 (6.36)	R-33.3 (5.87)	0.030 (0.17)	R-33.8 (5.96)	0.030 (0.17)	R-34.1 (6.00)	0.029 (0.17)
R-23.6 (4.16)	R-45.1 (7.95)	R-35.9 (6.32)*	0.028 (0.16)*	R-36.5 (6.43)*	0.027 (0.16)*	R-36.8 (6.49)*	0.027 (0.15)*
R-26.6 (4.68)	R-42.1 (7.42)	R-38.5 (6.77)	0.026 (0.15)	R-39.2 (6.91)	0.025 (0.14)	R-39.6 (6.98)	0.025 (0.14)
R-29.6 (5.21)	R-51.1 (9.01)	R-41.0 (7.22)*	0.024 (0.14)*	R-41.9 (7.38)*	0.024 (0.14)*	R-42.4 (7.46)*	0.024 (0.13)*
R-32.6 (5.74)	R-54.1 (9.54)	R-43.5 (7.67)*	0.023 (0.13)*	R-44.6 (7.85)*	0.022 (0.13)*	R-45.1 (7.95)*	0.022 (0.13)*
R-35.6 (6.27)	R-57.1 (10.06)	R-46.0 (8.11)*	0.022 (0.12)*	R-47.2 (8.32)*	0.021 (0.12)*	R-47.9 (8.43)*	0.021 (0.12)*
R-38.6 (6.80)	R-54.1 (9.54)	R-48.5 (8.54)	0.021 (0.12)	R-49.9 (8.79)	0.020 (0.11)	R-50.6 (8.91)	0.020 (0.11)

*Indicates interpolated value

Detail 8.1.36

Exterior and Interior Insulated 2x4 Wood Stud (24" o.c.) Wall Assembly with Protected SOPREMA SOPRA-ISO V PLUS and ACS-S Thermal Clip Supporting Metal Cladding with R-13 Cellulose Insulation in Stud Cavity - Clear Wall

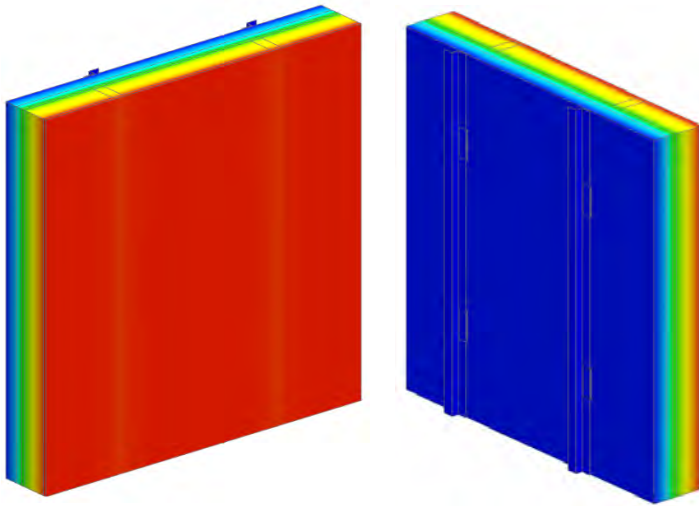

View from Interior

View from Exterior

Thermal Performance Indicators

Assembly 1D (Nominal) R-Value	R_{1D}	R-15.5 (2.74 RSI) + exterior insulation
Transmittance / Resistance	U_o / R_o	"Clear wall" U- and R-value

Nominal (1D) vs. Assembly Performance Indicators

Exterior Insulation 1D R-value (RSI)	R_{1D} ft ² ·hr·°F / Btu (m ² K / W)	24" Vertical Spacing		36" Vertical Spacing		48" Vertical Spacing	
		R_o ft ² ·hr·°F / Btu (m ² K / W)	U_o Btu/ft ² ·hr ·°F (W/m ² K)	R_o ft ² ·hr·°F / Btu (m ² K / W)	U_o Btu/ft ² ·hr ·°F (W/m ² K)	R_o ft ² ·hr·°F / Btu (m ² K / W)	U_o Btu/ft ² ·hr ·°F (W/m ² K)
R-14.6 (2.57)	R-30.1 (5.31)	R-28.6 (5.03)	0.035 (0.20)	R-29.0 (5.10)	0.035 (0.20)	R-29.1 (5.13)	0.034 (0.19)
R-17.6 (3.10)	R-39.1 (6.89)	R-31.4 (5.54)*	0.032 (0.18)*	R-31.8 (5.60)*	0.031 (0.18)*	R-32.0 (5.63)*	0.031 (0.18)*
R-20.6 (3.63)	R-36.1 (6.36)	R-34.3 (6.04)	0.029 (0.17)	R-34.6 (6.10)	0.029 (0.16)	R-34.8 (6.14)	0.029 (0.16)
R-23.6 (4.16)	R-45.1 (7.95)	R-37.0 (6.51)*	0.027 (0.15)*	R-37.4 (6.59)*	0.027 (0.15)*	R-37.7 (6.64)*	0.027 (0.15)*
R-26.6 (4.68)	R-42.1 (7.42)	R-39.7 (6.99)	0.025 (0.14)	R-40.2 (7.08)	0.025 (0.14)	R-40.5 (7.14)	0.025 (0.14)
R-29.6 (5.21)	R-51.1 (9.01)	R-42.4 (7.47)*	0.024 (0.13)*	R-43.0 (7.57)*	0.023 (0.13)*	R-43.4 (7.64)*	0.023 (0.13)*
R-32.6 (5.74)	R-54.1 (9.54)	R-45.1 (7.94)*	0.022 (0.13)*	R-45.8 (8.06)*	0.022 (0.12)*	R-46.2 (8.14)*	0.022 (0.12)*
R-35.6 (6.27)	R-57.1 (10.06)	R-47.7 (8.40)*	0.021 (0.12)*	R-48.5 (8.55)*	0.021 (0.12)*	R-49.0 (8.63)*	0.020 (0.12)*
R-38.6 (6.80)	R-54.1 (9.54)	R-50.3 (8.86)	0.020 (0.11)	R-51.3 (9.03)	0.020 (0.11)	R-51.8 (9.13)	0.019 (0.11)

*Indicates interpolated value

Detail 8.1.37

Exterior and Interior Insulated 2x6 Wood Stud (8" o.c.) Wall Assembly with Wood Strapping and Continuous Insulation Supporting Rainscreen Fiber Cement Board and R-19 Batt Insulation in Stud Cavity – Clear Wall

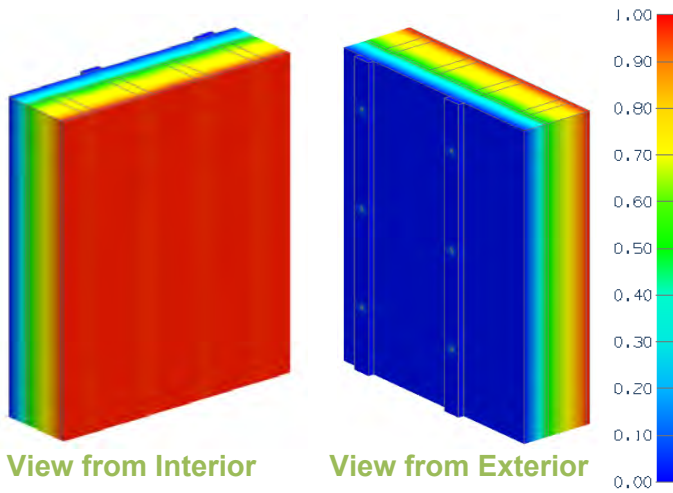

Thermal Performance Indicators

Assembly 1D (Nominal) R-Value	R_{1D}	R-21.5 (3.80 RSI) + exterior insulation
Transmittance / Resistance	U_o, R_o	"clear wall" U- and R-value

Nominal (1D) vs. Assembly Performance Indicators

Exterior Insulation 1D R-Value (RSI)	R_{1D} ft ² ·hr·°F / Btu (m ² K / W)	R_o ft ² ·hr·°F / Btu (m ² K / W)	U_o Btu/ft ² ·hr ·°F (W/m ² K)
R-0.0 (0.00)	R-21.5 (3.80)	R-18.1 (3.19)	0.055 (0.31)
R-5.0 (0.88)	R-26.5 (4.68)	R-23.1 (4.07)	0.043 (0.25)
R-15.0 (2.64)	R-36.5 (6.44)	R-32.6 (5.75)	0.031 (0.17)

Detail 8.2.1

Exterior and Interior Insulated 2x6 Wood Stud (16" o.c.) Wall Assembly with Wood Strapping Supporting Fiber Cement Board and R-19 Batt Insulation in Stud Cavity - Rim Joist and Floor Intersection with Metal Flashing Bypassing Exterior Insulation

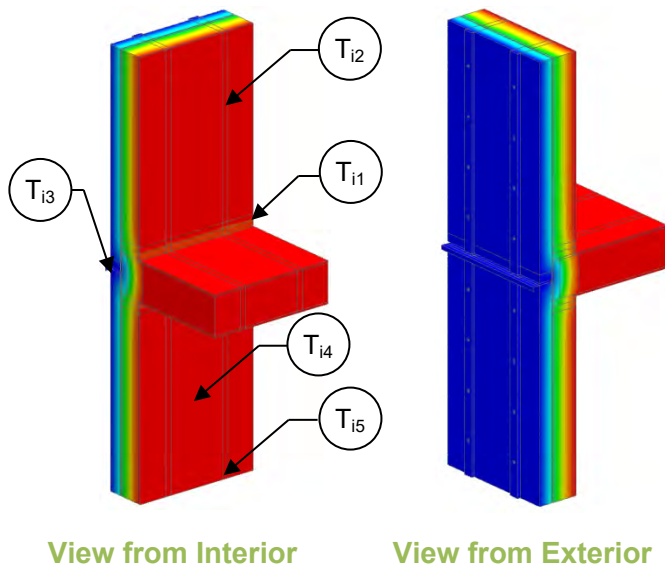

Thermal Performance Indicators

Assembly 1D (Nominal) R-Value	R_{1D}	R-21.5 (3.80 RSI) + exterior insulation
Transmittance / Resistance without Anomaly	U_o, R_o	"clear wall" U- and R-value, without floor
Transmittance / Resistance	U, R	U and R-values for the overall assembly
Surface Temperature Index ¹	T_i	0 = exterior temperature 1 = interior temperature
Linear Transmittance	ψ	Incremental increase in transmittance per linear length of wood framed floor

¹Assumptions and limitations for surface temperatures identified in ASHRAE 1365-RP

Nominal (1D) vs. Assembly Performance Indicators

Exterior Insulation 1D R-Value (RSI)	R_{1D} ft ² ·hr·°F / Btu (m ² K / W)	R_o ft ² ·hr·°F / Btu (m ² K / W)	U_o Btu/ft ² ·hr·°F (W/m ² K)	R ft ² ·hr·°F / Btu (m ² K / W)	U Btu/ft ² ·hr·°F (W/m ² K)	ψ Btu/ft·hr·°F (W/m K)
R-0 (0.00)	R-21.5 (3.80)	R-19.7 (3.47)	0.051 (0.29)	R-17.0 (3.00)	0.059 (0.33)	0.070 (0.122)
R-5 (0.88)	R-26.5 (4.68)	R-24.6 (4.32)	0.041 (0.23)	R-21.6 (3.81)	0.046 (0.26)	0.049 (0.084)
R-10 (1.76)	R-31.5 (5.56)	R-29.2 (5.14)	0.034 (0.20)	R-25.3 (4.46)	0.039 (0.22)	0.046 (0.080)
R-15 (2.64)	R-36.5 (6.44)	R-33.6 (5.92)	0.030 (0.17)	R-28.8 (5.06)	0.035 (0.20)	0.045 (0.077)

Temperature Indices

	R0	R5	R10	R15	
T_{i1}	-	0.25	0.35	0.39	Min T on sheathing, at floor intersection
T_{i2}	-	0.36	0.47	0.54	Max T on sheathing, at studs between fasteners
T_{i3}	0.15	0.28	0.32	0.35	Min T on rim joist, between floor joists
T_{i4}	0.06	-	-	-	Min T on sheathing, between studs in stud cavity
T_{i5}	0.16	-	-	-	Max T on sheathing, at studs



Detail 8.2.2

Exterior and Interior Insulated 2x6 Wood Stud (16" o.c.) Wall Assembly with Wood Strapping Supporting Fiber Cement Board and R-19 Batt Insulation in Stud Cavity - Rim Joist and Floor Intersection without Metal Flashing Bypassing Exterior Insulation

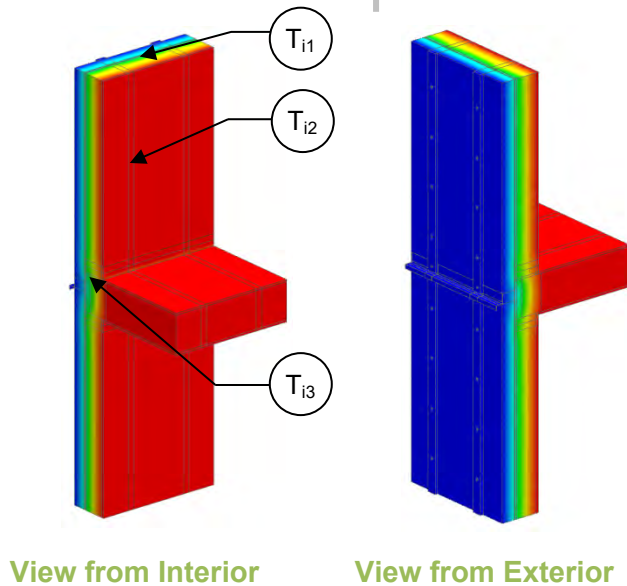

Thermal Performance Indicators

Assembly 1D (Nominal) R-Value	R _{1D}	R-21.5 (3.80 RSI) + exterior insulation
Transmittance / Resistance without Anomaly	U _o , R _o	"clear wall" U- and R-value, without floor
Transmittance / Resistance	U, R	U and R-values for the overall assembly
Surface Temperature Index ¹	T _i	0 = exterior temperature 1 = interior temperature
Linear Transmittance	ψ	Incremental increase in transmittance per linear length of wood framed floor

¹Assumptions and limitations for surface temperatures identified in ASHRAE 1365-RP

Nominal (1D) vs. Assembly Performance Indicators

Exterior Insulation 1D R-Value (RSI)	R _{1D} ft ² ·hr·°F / Btu (m ² K / W)	R _o ft ² ·hr·°F / Btu (m ² K / W)	U _o Btu/ft ² ·hr ·°F (W/m ² K)	R ft ² ·hr·°F / Btu (m ² K / W)	U Btu/ft ² ·hr ·°F (W/m ² K)	ψ Btu/ft ·hr·°F (W/m K)
R-5 (0.88)	R-26.5 (4.68)	R-24.6 (4.32)	0.041 (0.23)	R-21.9 (3.85)	0.046 (0.26)	0.044 (0.076)
R-10 (1.76)	R-31.5 (5.56)	R-29.2 (5.14)	0.034 (0.20)	R-26.1 (4.6)	0.038 (0.22)	0.035 (0.061)
R-15 (2.64)	R-36.5 (6.44)	R-33.6 (5.92)	0.030 (0.17)	R-30.1 (5.3)	0.033 (0.19)	0.031 (0.054)

Temperature Indices

	R5	R10	R15	
T _{i1}	0.25	0.38	0.46	Min T on sheathing, between studs at centre of stud cavity
T _{i2}	0.35	0.47	0.54	Max T on sheathing, at studs between fasteners
T _{i3}	0.33	0.43	0.61	Min T on rim joist, between floor joists

Detail 8.2.3

Exterior and Interior Insulated 2x6 Wood Stud (16" o.c.) Wall Assembly with Wood Strapping Supporting Fiber Cement Board and R-19 Batt Insulation in Stud Cavity – Cantilevered Wood Joist Balcony Intersection

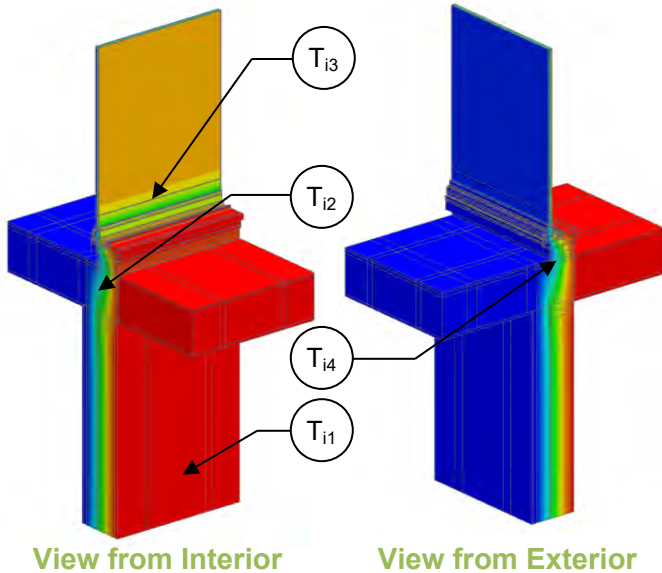

Thermal Performance Indicators

Assembly 1D (Nominal) R-Value	R_{1D}	R-21.6 (3.80 RSI) + exterior insulation
Transmittance / Resistance without Anomaly	U_w , R_w , U_g	"clear wall" U- and R-value w = wood framed wall without balcony g = glazed sliding door
Transmittance / Resistance	U, R	U and R-values for the overall assembly
Surface Temperature Index ¹	T_i	0 = exterior temperature 1 = interior temperature
Linear Transmittance	ψ	Incremental increase in transmittance per linear length of balcony

¹Assumptions and limitations for surface temperatures identified in ASHRAE 1365-RP

Nominal (1D) vs. Assembly Performance Indicators

Base Assembly – Wall

Exterior Insulation 1D R-Value (RSI)	R_{1D} ft ² ·hr·°F / Btu (m ² K / W)	R_w ft ² ·hr·°F / Btu (m ² K / W)	U_w Btu/ft ² ·hr·°F (W/m ² K)
R-10 (1.76)	R-31.6 (5.56)	R-29.2 (5.14)	0.034 (0.19)
R-15 (2.64)	R-36.6 (6.44)	R-33.7 (5.93)	0.030 (0.17)

Base Assembly – Sliding Door

$U_{\text{centre of glass}}$ Btu/ft ² ·hr·°F (W/m ² K)	U_g Btu/ft ² ·hr·°F (W/m ² K)
0.321 (1.82)	0.323 (1.83)

Balcony Transition Linear Transmittance

Exterior Insulation 1D R-Value (RSI)	R ft ² ·hr·°F / Btu (m ² K / W)	U Btu/ft ² ·hr·°F (W/m ² K)	ψ Btu/ft·hr·°F (W/m K)
R-10 (1.76)	R-5.9 (1.04)	0.170 (0.97)	0.072 (0.125)
R-15 (2.64)	R-6.0 (1.06)	0.166 (0.95)	0.067 (0.115)

Temperature Indices

	R10	R15	
T_{i1}	0.34	0.43	Min T on sheathing, between studs and at fasteners
T_{i2}	0.45	0.54	Max T on sheathing, below floor header beam
T_{i3}	0.49	0.49	Min T on frame, at edge of glass
T_{i4}	0.31	0.34	Min T on rim joist, between floor joists

Detail 8.2.4

Exterior and Interior Insulated 2x6 Wood Stud (16" o.c.) Wall Assembly with Wood Strapping Supporting Fiber Cement Board and R-19 Batt Insulation in Stud Cavity – Independently Supported Balcony Intersection

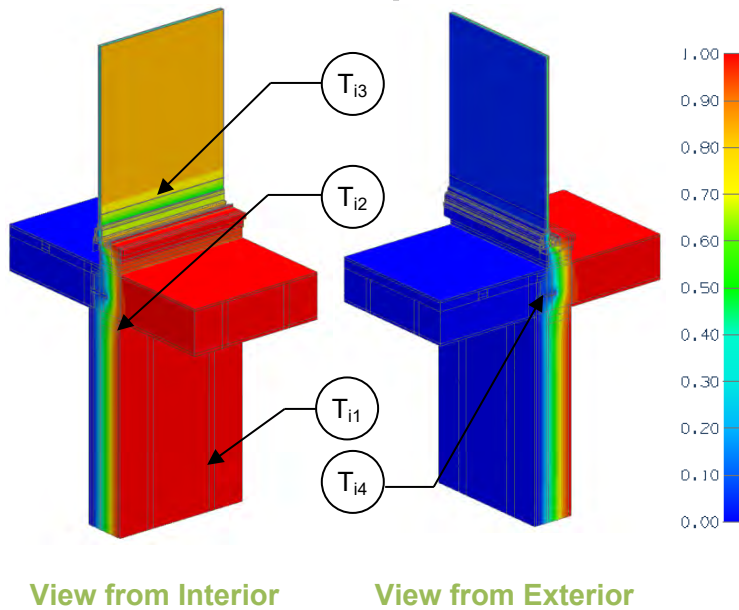

Thermal Performance Indicators

Assembly 1D (Nominal) R-Value	R_{1D}	R-21.6 (3.80 RSI) + exterior insulation
Transmittance / Resistance without Anomaly	U_w , R_w , U_g	"clear wall" U- and R-value w = wood framed wall without balcony g = glazed sliding door
Transmittance / Resistance	U, R	U and R-values for the overall assembly
Surface Temperature Index ¹	T_i	0 = exterior temperature 1 = interior temperature
Linear Transmittance	ψ	Incremental increase in transmittance per linear length of balcony

¹Assumptions and limitations for surface temperatures identified in ASHRAE 1365-RP

Nominal (1D) vs. Assembly Performance Indicators

Base Assembly – Wall

Exterior Insulation 1D R-Value (RSI)	R_{1D} ft ² ·hr·°F / Btu (m ² K / W)	R_w ft ² ·hr·°F / Btu (m ² K / W)	U_w Btu/ft ² ·hr·°F (W/m ² K)
R-10 (1.76)	R-31.6 (5.56)	R-29.2 (5.14)	0.034 (0.19)
R-15 (2.64)	R-36.6 (6.44)	R-33.7 (5.93)	0.030 (0.17)

Base Assembly – Sliding Door

$U_{\text{centre of glass}}$ Btu/ft ² ·hr·°F (W/m ² K)	U_g Btu/ft ² ·hr·°F (W/m ² K)
0.321 (1.82)	0.323 (1.83)

Balcony Transition Linear Transmittance

Exterior Insulation 1D R-Value (RSI)	R ft ² ·hr·°F / Btu (m ² K / W)	U Btu/ft ² ·hr·°F (W/m ² K)	ψ Btu/ft·hr·°F (W/m K)
R-10 (1.76)	R-5.9 (1.04)	0.169 (0.96)	0.083 (0.143)
R-15 (2.64)	R-6.0 (1.06)	0.166 (0.94)	0.078 (0.134)

Temperature Indices

	R10	R15	
T_{i1}	0.37	0.43	Min T on sheathing, at fasteners along studs
T_{i2}	0.43	0.51	Max T on sheathing, at studs below floor header beam
T_{i3}	0.49	0.49	Min T on frame, at edge of glass
T_{i4}	0.22	0.22	Min T at balcony bolts, between floor joists

Detail 8.2.5

Exterior and Interior Insulated 2x6 Wood Stud (16" o.c.) Wall Assembly with Wood Strapping and Continuous Insulation Supporting Fiber Cement Board and R-19 Batt Insulation in Stud Cavity – Cantilevered Floor Intersection

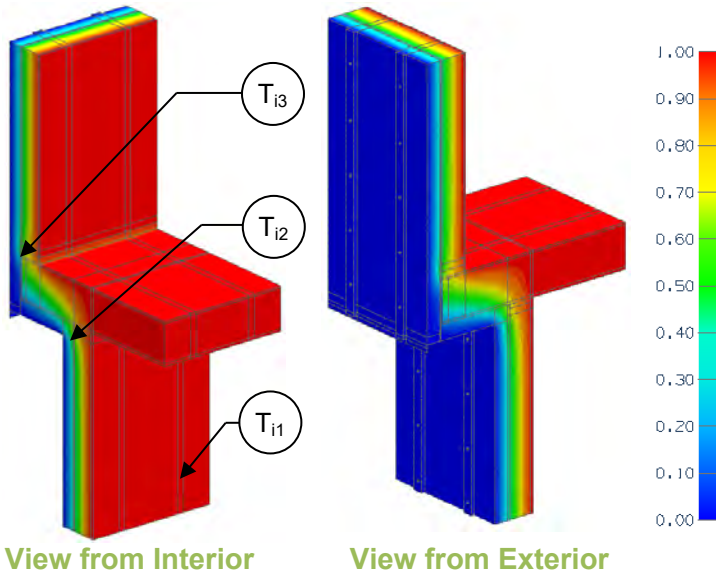

Thermal Performance Indicators

Assembly 1D (Nominal) R-Value	R_{1D}	R-21.6 (3.80 RSI) + exterior insulation
Transmittance / Resistance without Anomaly	U_w, R_w, U_f, R_f	“clear field” U- and R-value w = wood framed wall without floor f = floor assembly
Transmittance / Resistance	U, R	U and R-values for the overall assembly
Surface Temperature Index ¹	T_i	0 = exterior temperature 1 = interior temperature
Linear Transmittance	ψ	Incremental increase in transmittance per linear length of soffit

¹Assumptions and limitations for surface temperatures identified in ASHRAE 1365-RP

Nominal (1D) vs. Assembly Performance Indicators

Base Assembly – Wall

Exterior Insulation 1D R-Value (RSI)	R_{1D} ft ² ·hr·°F / Btu (m ² K / W)	R_w ft ² ·hr·°F / Btu (m ² K / W)	U_w Btu/ft ² ·hr·°F (W/m ² K)
R-10 (1.76)	R-31.6 (5.56)	R-29.2 (5.14)	0.034 (0.19)
R-15 (2.64)	R-36.6 (6.44)	R-33.7 (5.93)	0.030 (0.17)

Base Assembly – Floor

Exterior Insulation 1D R-Value (RSI)	R_f ft ² ·hr·°F / Btu (m ² K / W)	U_f Btu/ft ² ·hr·°F (W/m ² K)
R-10 (1.76)	R-31.4 (5.53)	0.032 (0.18)
R-15 (2.64)	R-36.1 (6.36)	0.028 (0.16)

Floor Transition Linear Transmittance

Exterior Insulation 1D R-Value (RSI)	R ft ² ·hr·°F / Btu (m ² K / W)	U Btu/ft ² ·hr·°F (W/m ² K)	ψ Btu/ft·hr·°F (W/m K)
R-10 (1.76)	R-26.2 (4.61)	0.04 (0.22)	0.034 (0.059)
R-15 (2.64)	R-31.2 (5.49)	0.03 (0.18)	0.021 (0.036)

Temperature Indices

	R10	R15	
T_{i1}	0.36	0.43	Min T on sheathing, at fasteners along studs
T_{i2}	0.67	0.75	Max T on sheathing, below floor at bottom of header plate
T_{i3}	0.13	0.26	Min T on rim joist and overhang sheathing, at beam and overhang sheathing intersection

Detail 8.2.6

Interior Insulated Double Framed Wall 2x6 and 2x4 Wood Stud (16" o.c.) Wall Assembly with 2" Gap – Rim Joist and Floor Intersection

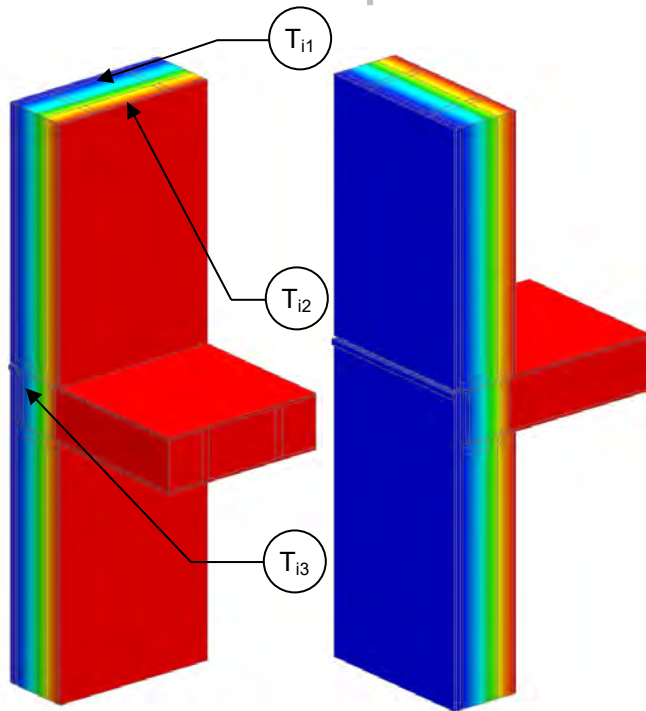

View from Interior

View from Exterior

Thermal Performance Indicators

Assembly 1D (Nominal) R-Value	R_{1D}	R-2.5 (0.44 RSI) + fill insulation
Transmittance / Resistance without Anomaly	U_o, R_o	"clear wall" U- and R-value, without floor
Transmittance / Resistance	U, R	U and R-values for the overall assembly
Surface Temperature Index ¹	T_i	0 = exterior temperature 1 = interior temperature
Linear Transmittance	ψ	Incremental increase in transmittance per linear length of wood framed floor

¹Assumptions and limitations for surface temperatures identified in ASHRAE 1365-RP

Nominal (1D) vs. Assembly Performance Indicators

Fill Insulation 1D R-Value (RSI)	R_{1D} ft ² ·hr·°F / Btu (m ² K / W)	R_o ft ² ·hr·°F / Btu (m ² K / W)	U_o Btu/ft ² ·hr ·°F (W/m ² K)	R ft ² ·hr·°F / Btu (m ² K / W)	U Btu/ft ² ·hr ·°F (W/m ² K)	ψ Btu/ft ·hr·°F (W/m K)
R-38.5 (6.78)	R-41.0 (7.23)	R-38.0 (6.70)	0.026 (0.15)	R-36.4 (6.42)	0.027 (0.16)	0.010 (0.018)
R-44.0 (7.75)	R-46.5 (8.19)	R-42.4 (7.47)	0.024 (0.13)	R-40.1 (7.07)	0.025 (0.14)	0.012 (0.020)
R-55.0 (9.69)	R-57.5 (10.13)	R-50.8 (8.94)	0.020 (0.11)	R-47.2 (8.31)	0.021 (0.12)	0.013 (0.023)
R-66.0 (11.62)	R-68.5 (12.07)	R-58.9 (10.37)	0.017 (0.10)	R-53.7 (9.46)	0.019 (0.11)	0.014 (0.025)

Temperature Indices

	R38.5	R44.0	R55.0	R66.0	
T_{i1}	0.03	0.03	0.02	0.02	Min T on sheathing, between studs at centre of stud cavity
T_{i2}	0.95	0.95	0.95	0.96	Min T on gypsum, between studs at centre of stud cavity
T_{i3}	0.09	0.09	0.08	0.07	Min T on rim joist, between floor joists

Detail 8.2.7

Interior Insulated Double Framed Wall 2x6 and 2x4 Wood Stud (16" o.c.) Wall Assembly with 3" Gap – Rim Joist and Floor Intersection

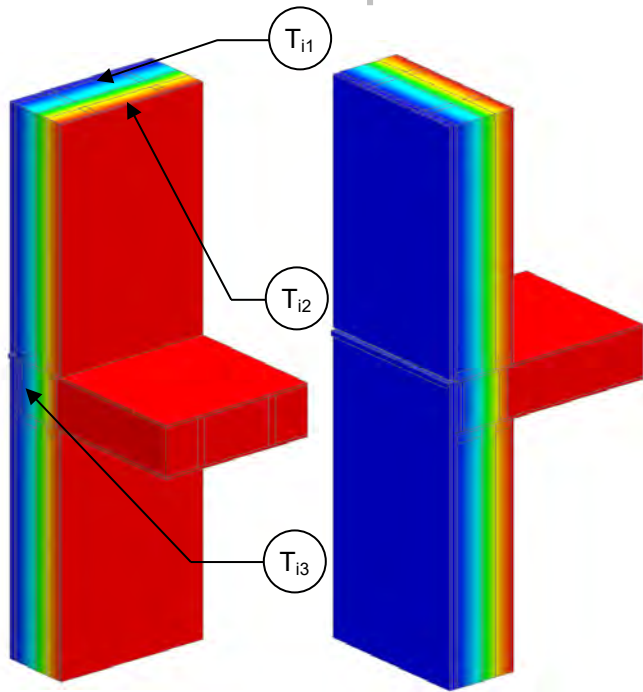

Thermal Performance Indicators

Assembly 1D (Nominal) R-Value	R_{1D}	R-2.5 (0.44 RSI) + fill insulation
Transmittance / Resistance without Anomaly	U_o, R_o	"clear wall" U- and R-value, without floor
Transmittance / Resistance	U, R	U and R-values for the overall assembly
Surface Temperature Index ¹	T_i	0 = exterior temperature 1 = interior temperature
Linear Transmittance	ψ	Incremental increase in transmittance per linear length of wood framed floor

¹Assumptions and limitations for surface temperatures identified in ASHRAE 1365-RP

View from Interior

View from Exterior

Nominal (1D) vs. Assembly Performance Indicators

Fill Insulation 1D R-Value (RSI)	R_{1D} ft ² ·hr·°F / Btu (m ² K / W)	R_o ft ² ·hr·°F / Btu (m ² K / W)	U_o Btu/ft ² ·hr ·°F (W/m ² K)	R ft ² ·hr·°F / Btu (m ² K / W)	U Btu/ft ² ·hr ·°F (W/m ² K)	ψ Btu/ft ·hr·°F (W/m K)
R-42.0 (7.40)	R-44.5 (7.84)	R-41.6 (7.32)	0.024 (0.14)	R-39.9 (7.02)	0.025 (0.14)	0.009 (0.016)
R-48.0 (8.45)	R-50.5 (8.90)	R-46.4 (8.18)	0.022 (0.12)	R-44.1 (7.76)	0.023 (0.13)	0.010 (0.017)
R-60.0 (10.57)	R-62.5 (11.01)	R-55.9 (9.84)	0.018 (0.10)	R-52.1 (9.17)	0.019 (0.11)	0.011 (0.020)
R-72.0 (12.68)	R-74.5 (13.13)	R-65.0 (11.45)	0.015 (0.09)	R-59.6 (10.49)	0.017 (0.10)	0.012 (0.021)

Temperature Indices

	R42.0	R48.0	R60.0	R72.0	
T_{i1}	0.03	0.02	0.02	0.02	Min T on sheathing, between studs at centre of stud cavity
T_{i2}	0.95	0.96	0.96	0.96	Min T on gypsum, between studs at centre of stud cavity
T_{i3}	0.08	0.08	0.07	0.06	Min T on rim joist, between floor joists

Detail 8.2.8

Interior Insulated Double Framed Wall 2x6 and 2x4 Wood Stud (16" o.c.) Wall Assembly with 4" Gap – Rim Joist and Floor Intersection

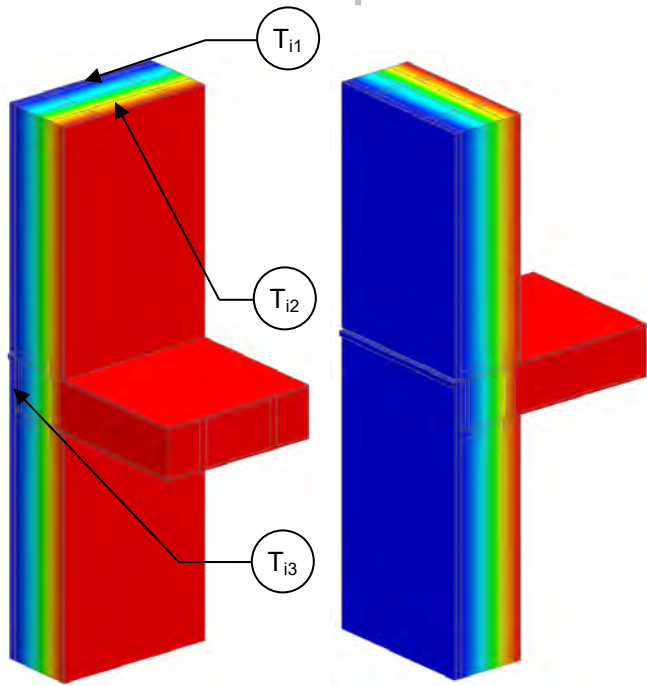

View from Interior

View from Exterior

Thermal Performance Indicators

Assembly 1D (Nominal) R-Value	R_{1D}	R-2.5 (0.44 RSI) + fill insulation
Transmittance / Resistance without Anomaly	U_o, R_o	"clear wall" U- and R-value, without floor
Transmittance / Resistance	U, R	U and R-values for the overall assembly
Surface Temperature Index ¹	T_i	0 = exterior temperature 1 = interior temperature
Linear Transmittance	ψ	Incremental increase in transmittance per linear length of wood framed floor

¹Assumptions and limitations for surface temperatures identified in ASHRAE 1365-RP

Nominal (1D) vs. Assembly Performance Indicators

Fill Insulation 1D R-Value (RSI)	R_{1D} ft ² ·hr·°F / Btu (m ² K / W)	R_o ft ² ·hr·°F / Btu (m ² K / W)	U_o Btu/ft ² ·hr ·°F (W/m ² K)	R ft ² ·hr·°F / Btu (m ² K / W)	U Btu/ft ² ·hr ·°F (W/m ² K)	ψ Btu/ft ·hr·°F (W/m K)
R-45.5 (8.01)	R-48.0 (8.46)	R-45.1 (7.94)	0.022 (0.13)	R-43.3 (7.62)	0.023 (0.13)	0.008 (0.014)
R-52.0 (9.16)	R-54.5 (9.60)	R-50.5 (8.89)	0.020 (0.11)	R-48.0 (8.45)	0.021 (0.12)	0.009 (0.016)
R-65.0 (11.45)	R-67.5 (11.89)	R-60.9 (10.73)	0.016 (0.09)	R-56.9 (10.03)	0.018 (0.10)	0.010 (0.018)
R-78.0 (13.74)	R-80.5 (14.18)	R-71.1 (12.52)	0.014 (0.08)	R-65.3 (11.51)	0.015 (0.09)	0.011 (0.019)

Temperature Indices

	R45.5	R52.0	R65.0	R78.0	
T_{i1}	0.02	0.02	0.02	0.02	Min T on sheathing, between studs at centre of stud cavity
T_{i2}	0.96	0.96	0.96	0.96	Min T on gypsum, between studs at centre of stud cavity
T_{i3}	0.07	0.07	0.07	0.06	Min T on rim joist, between floor joists

Detail 8.2.9

Interior Insulated Double Framed Wall 2x6 and 2x4 Wood Stud (16" o.c.) Wall Assembly with 2" Gap – Insulated Rim Joist and Floor Intersection

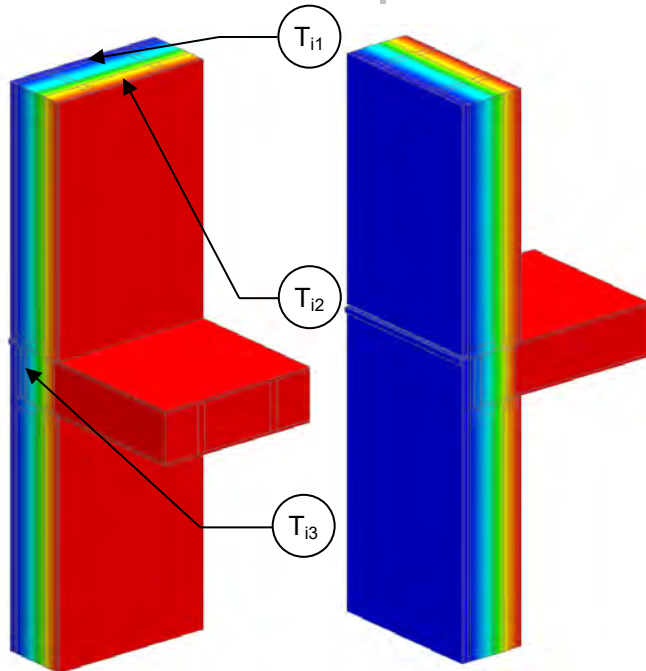

View from Interior

View from Exterior

Thermal Performance Indicators

Assembly 1D (Nominal) R-Value	R_{1D}	R-2.5 (0.44 RSI) + fill insulation
Transmittance / Resistance without Anomaly	U_o, R_o	"clear wall" U- and R-value, without floor
Transmittance / Resistance	U, R	U and R-values for the overall assembly
Surface Temperature Index ¹	T_i	0 = exterior temperature 1 = interior temperature
Linear Transmittance	ψ	Incremental increase in transmittance per linear length of wood framed floor

¹Assumptions and limitations for surface temperatures identified in ASHRAE 1365-RP

Nominal (1D) vs. Assembly Performance Indicators

Fill Insulation 1D R-Value (RSI)	R_{1D} ft ² ·hr·°F / Btu (m ² K / W)	R_o ft ² ·hr·°F / Btu (m ² K / W)	U_o Btu/ft ² ·hr ·°F (W/m ² K)	R ft ² ·hr·°F / Btu (m ² K / W)	U Btu/ft ² ·hr ·°F (W/m ² K)	ψ Btu/ft ·hr·°F (W/m K)
R-38.5 (6.78)	R-41.0 (7.23)	R-38.0 (6.70)	0.026 (0.15)	R-36.6 (6.44)	0.027 (0.16)	0.009 (0.016)
R-44.0 (7.75)	R-46.5 (8.19)	R-42.4 (7.47)	0.024 (0.13)	R-40.3 (7.09)	0.025 (0.14)	0.011 (0.019)
R-55.0 (9.69)	R-57.5 (10.13)	R-50.8 (8.94)	0.020 (0.11)	R-47.3 (8.32)	0.021 (0.12)	0.013 (0.022)
R-66.0 (11.62)	R-68.5 (12.07)	R-58.9 (10.37)	0.017 (0.10)	R-53.8 (9.47)	0.019 (0.11)	0.014 (0.025)

Temperature Indices

	R38.5	R44.0	R55.0	R66.0	
T_{i1}	0.03	0.03	0.02	0.02	Min T on sheathing, between studs at centre of stud cavity
T_{i2}	0.95	0.95	0.95	0.96	Min T on gypsum, between studs at centre of stud cavity
T_{i3}	0.15	0.14	0.14	0.13	Min T on rim joist, between floor joists

Detail 8.2.10

Interior Insulated Double Framed Wall 2x6 and 2x4 Wood Stud (16" o.c.) Wall Assembly with 3" Gap – Insulated Rim Joist and Floor Intersection

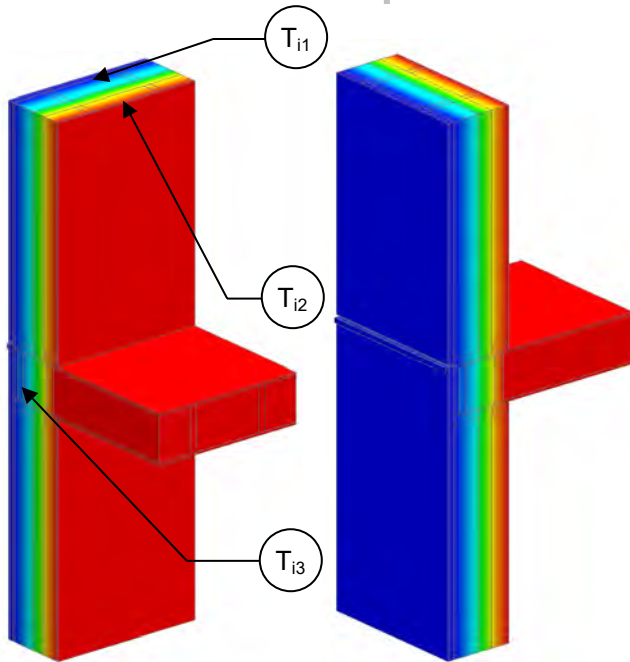

Thermal Performance Indicators

Assembly 1D (Nominal) R-Value	R_{1D}	R-2.5 (0.44 RSI) + fill insulation
Transmittance / Resistance without Anomaly	U_o, R_o	"clear wall" U- and R-value, without floor
Transmittance / Resistance	U, R	U and R-values for the overall assembly
Surface Temperature Index ¹	T_i	0 = exterior temperature 1 = interior temperature
Linear Transmittance	ψ	Incremental increase in transmittance per linear length of wood framed floor

¹Assumptions and limitations for surface temperatures identified in ASHRAE 1365-RP

View from Interior

View from Exterior

Nominal (1D) vs. Assembly Performance Indicators

Fill Insulation 1D R-Value (RSI)	R_{1D} ft ² ·hr·°F / Btu (m ² K / W)	R_o ft ² ·hr·°F / Btu (m ² K / W)	U_o Btu/ft ² ·hr ·°F (W/m ² K)	R ft ² ·hr·°F / Btu (m ² K / W)	U Btu/ft ² ·hr ·°F (W/m ² K)	ψ Btu/ft ·hr·°F (W/m K)
R-42.0 (7.40)	R-44.5 (7.84)	R-41.6 (7.32)	0.024 (0.14)	R-40.0 (7.04)	0.025 (0.14)	0.008 (0.014)
R-48.0 (8.45)	R-50.5 (8.90)	R-46.4 (8.18)	0.022 (0.12)	R-44.2 (7.78)	0.023 (0.13)	0.010 (0.017)
R-60.0 (10.57)	R-62.5 (11.01)	R-55.9 (9.84)	0.018 (0.10)	R-52.2 (9.18)	0.019 (0.11)	0.011 (0.019)
R-72.0 (12.68)	R-74.5 (13.13)	R-65.0 (11.45)	0.015 (0.09)	R-59.6 (10.50)	0.017 (0.10)	0.012 (0.021)

Temperature Indices

	R42.0	R48.0	R60.0	R72.0	
T_{i1}	0.03	0.03	0.02	0.02	Min T on sheathing, between studs at centre of stud cavity
T_{i2}	0.96	0.96	0.96	0.96	Min T on gypsum, between studs at centre of stud cavity
T_{i3}	0.14	0.13	0.13	0.12	Min T on rim joist, between floor joists

Detail 8.2.11

Interior Insulated Double Framed Wall 2x6 and 2x4 Wood Stud (16" o.c.) Wall Assembly with 4" Gap – Insulated Rim Joist and Floor Intersection

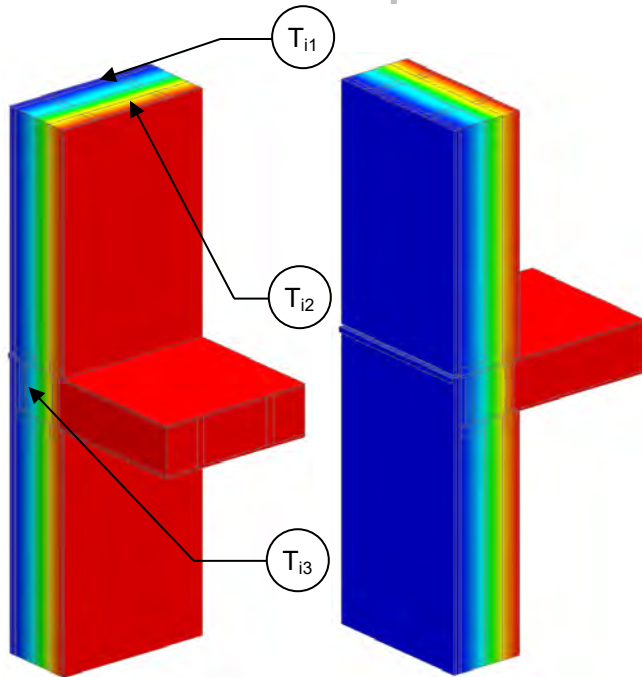

Thermal Performance Indicators

Assembly 1D (Nominal) R-Value	R_{1D}	R-2.5 (0.44 RSI) + fill insulation
Transmittance / Resistance without Anomaly	U_o, R_o	"clear wall" U- and R-value, without floor
Transmittance / Resistance	U, R	U and R-values for the overall assembly
Surface Temperature Index ¹	T_i	0 = exterior temperature 1 = interior temperature
Linear Transmittance	ψ	Incremental increase in transmittance per linear length of wood framed floor

¹Assumptions and limitations for surface temperatures identified in ASHRAE 1365-RP

View from Interior

View from Exterior

Nominal (1D) vs. Assembly Performance Indicators

Fill Insulation 1D R-Value (RSI)	R_{1D} ft ² ·hr·°F / Btu (m ² K / W)	R_o ft ² ·hr·°F / Btu (m ² K / W)	U_o Btu/ft ² ·hr ·°F (W/m ² K)	R ft ² ·hr·°F / Btu (m ² K / W)	U Btu/ft ² ·hr ·°F (W/m ² K)	ψ Btu/ft ·hr·°F (W/m K)
R-45.5 (8.01)	R-48.0 (8.46)	R-45.1 (7.94)	0.022 (0.13)	R-43.4 (7.65)	0.023 (0.13)	0.007 (0.013)
R-52.0 (9.16)	R-54.5 (9.60)	R-50.5 (8.89)	0.020 (0.11)	R-48.1 (8.47)	0.021 (0.12)	0.009 (0.015)
R-65.0 (11.45)	R-67.5 (11.89)	R-60.9 (10.73)	0.016 (0.09)	R-57.0 (10.04)	0.018 (0.10)	0.010 (0.017)
R-78.0 (13.74)	R-80.5 (14.18)	R-71.1 (12.52)	0.014 (0.08)	R-65.4 (11.51)	0.015 (0.09)	0.011 (0.019)

Temperature Indices

	R45.5	R52.0	R65.0	R78.0	
T_{i1}	0.03	0.02	0.02	0.02	Min T on sheathing, between studs at centre of stud cavity
T_{i2}	0.96	0.96	0.96	0.96	Min T on gypsum, between studs at centre of stud cavity
T_{i3}	0.13	0.12	0.11	0.11	Min T on rim joist, between floor joists

Detail 8.2.12

Exterior and Interior Insulated 2x6 Wood Stud (16" o.c.) Wall Assembly with Shelf Angle & Brick Ties Supporting Brick Veneer and R-19 Batt Insulation in Stud Cavity – Intermediate Floor Intersection

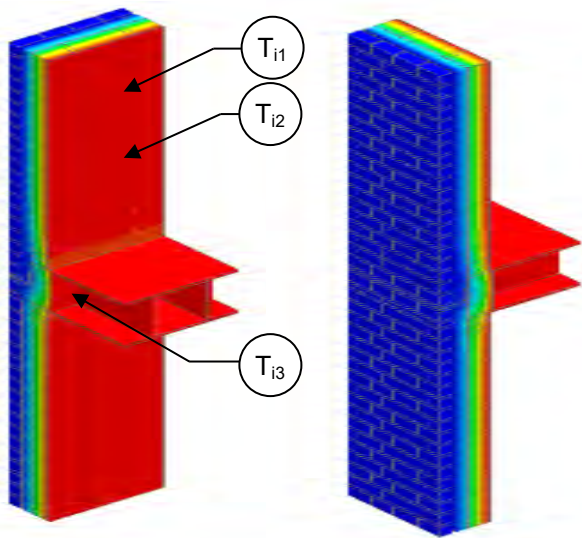

View from Interior

View from Exterior

Thermal Performance Indicators

Assembly 1D (Nominal) R-Value	R_{1D}	R-27.4 (4.83 RSI) + exterior insulation
Transmittance / Resistance without Anomaly	U_o, R_o	"clear wall" U- and R-value, without floor
Transmittance / Resistance	U, R	U and R-values for the overall assembly
Surface Temperature Index ¹	T_i	0 = exterior temperature 1 = interior temperature
Linear Transmittance	ψ	Incremental increase in transmittance per linear length of wood framed floor

¹Assumptions and limitations for surface temperatures identified in ASHRAE 1365-RP

Nominal (1D) vs. Assembly Performance Indicators

Exterior Insulation 1D R-Value (RSI)	R_{1D} ft ² ·hr·°F / Btu (m ² K / W)	R_o ft ² ·hr·°F / Btu (m ² K / W)	U_o Btu/ft ² ·hr·°F (W/m ² K)	R ft ² ·hr·°F / Btu (m ² K / W)	U Btu/ft ² ·hr·°F (W/m ² K)	ψ Btu/ft·hr·°F (W/m K)
R-0.0 (0.00)	R-27.4 (4.83)	R-19.8 (3.49)	0.050 (0.29)	R-18.5 (3.25)	0.054 (0.307)	0.034 (0.058)
R-10.0 (1.76)	R-37.4 (6.59)	R-28.0 (4.93)	0.036 (0.20)	R-24.4 (4.30)	0.041 (0.233)	0.048 (0.083)

Temperature Indices

	R0	R10	
T_{i1}	0.19	0.32	T on sheathing, at studs near brick ties
T_{i2}	0.15	0.42	T on sheathing, at studs between brick ties
T_{i3}	0.43	0.49	Min T on rim joist, between floor joists

Detail 8.2.13

Exterior and Interior Insulated 2x6 Wood Stud (16" o.c.) Wall Assembly with Stand-off (Knife Plate) Shelf Angle & Brick Ties Supporting Brick Veneer and R-19 Batt Insulation in Stud Cavity – Intermediate Floor Intersection

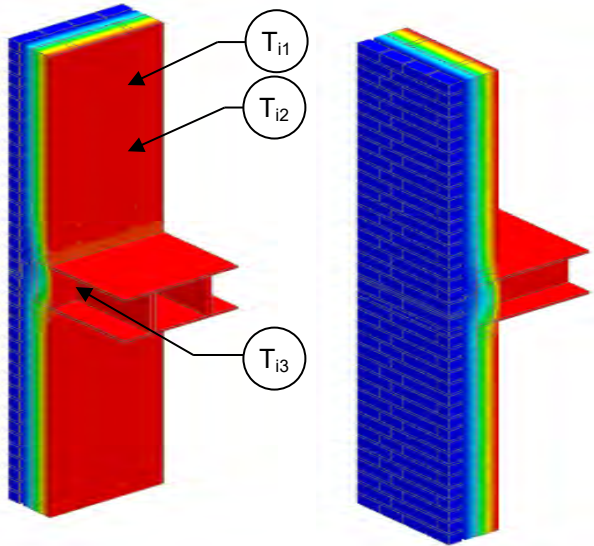

View from Interior

View from Exterior

Thermal Performance Indicators

Assembly 1D (Nominal) R-Value	R_{1D}	R-27.4 (4.83 RSI) + exterior insulation
Transmittance / Resistance without Anomaly	U_o, R_o	"clear wall" U- and R-value, without floor
Transmittance / Resistance	U, R	U and R-values for the overall assembly
Surface Temperature Index ¹	T_i	0 = exterior temperature 1 = interior temperature
Linear Transmittance	ψ	Incremental increase in transmittance per linear length of wood framed floor

¹Assumptions and limitations for surface temperatures identified in ASHRAE 1365-RP

Nominal (1D) vs. Assembly Performance Indicators

Exterior Insulation 1D R-Value (RSI)	R_{1D} ft ² ·hr·°F / Btu (m ² K / W)	R_o ft ² ·hr·°F / Btu (m ² K / W)	U_o Btu/ft ² ·hr ·°F (W/m ² K)	R ft ² ·hr·°F / Btu (m ² K / W)	U Btu/ft ² ·hr ·°F (W/m ² K)	ψ Btu/ft ·hr·°F (W/m K)
R-0.0 (0.00)	R-27.4 (4.83)	R-19.8 (3.49)	0.050 (0.29)	R-18.5 (3.26)	0.054 (0.307)	0.032 (0.056)
R-10.0 (1.76)	R-37.4 (6.59)	R-28.0 (4.93)	0.036 (0.20)	R-24.8 (4.36)	0.040 (0.229)	0.043 (0.074)

Temperature Indices

	R0	R10	
T_{i1}	0.19	0.34	T on sheathing, at studs near brick ties
T_{i2}	0.15	0.42	T on sheathing, at studs between brick ties
T_{i3}	0.24	0.30	Min T on rim joist, at fasteners

Detail 8.2.14

Exterior Insulated 2x6 Wood Stud (16" o.c.) Wall with Interior OSB and Wood Furring Assembly with Stand-off (Knife Plate) Shelf Angle & Brick Ties Supporting Brick Veneer – CLT and Wood Truss Floor Intersection

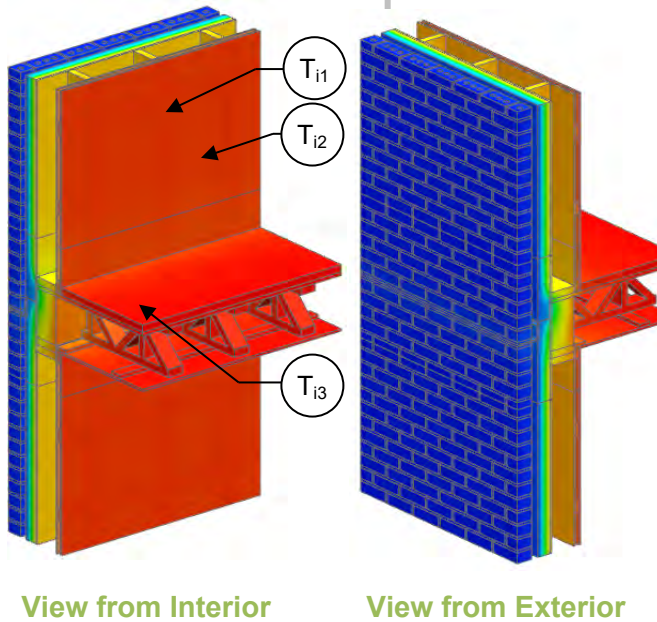

Thermal Performance Indicators

Assembly 1D (Nominal) R-Value	R _{1D}	R-5.3 (0.93 RSI) + exterior insulation
Transmittance / Resistance without Anomaly	U _o , R _o	"clear wall" U- and R-value, without floor
Transmittance / Resistance	U, R	U and R-values for the overall assembly
Surface Temperature Index ¹	T _i	0 = exterior temperature 1 = interior temperature
Linear Transmittance	ψ	Incremental increase in transmittance per linear length of wood framed floor

¹Assumptions and limitations for surface temperatures identified in ASHRAE 1365-RP

Nominal (1D) vs. Assembly Performance Indicators

Exterior Insulation 1D R-Value (RSI)	R _{1D} ft ² ·hr·°F / Btu (m ² K / W)	R _o ft ² ·hr·°F / Btu (m ² K / W)	U _o Btu/ft ² ·hr ·°F (W/m ² K)	R ft ² ·hr·°F / Btu (m ² K / W)	U Btu/ft ² ·hr ·°F (W/m ² K)	ψ Btu/ft ·hr·°F (W/m K)
R-10 (1.76)	R-15.3 (2.69)	R-14.3 (2.52)	0.070 (0.40)	R-13.8 (2.44)	0.072 (0.41)	0.019 (0.032)
R-15 (2.64)	R-20.3 (3.57)	R-17.9 (3.15)	0.056 (0.32)	R-16.7 (2.95)	0.060 (0.34)	0.030 (0.052)
R-20 (3.52)	R-25.3 (4.45)	R-21.1 (3.72)	0.047 (0.27)	R-19.2 (3.38)	0.052 (0.30)	0.037 (0.064)
R-25 (4.40)	R-30.3 (5.33)	R-24.1 (4.24)	0.041 (0.24)	R-21.4 (3.77)	0.047 (0.27)	0.041 (0.071)
R-30 (5.28)	R-35.3 (6.21)	R-26.9 (4.73)	0.037 (0.21)	R-23.4 (4.12)	0.043 (0.24)	0.044 (0.076)

Temperature Indices

	R10	R15	R20	R25	R30	
T _{i1}	0.62	0.66	0.69	0.71	0.73	Min T on sheathing, at studs near brick ties
T _{i2}	0.76	0.81	0.84	0.86	0.88	Max T on sheathing, between studs and brick ties
T _{i3}	0.88	0.88	0.89	0.90	0.90	Min T on CLT, near wood joists, behind shelf angle fasteners

Detail 8.2.15

Exterior and Interior Insulated 2x6 Wood Stud (16" o.c.) Wall with Interior OSB and Wood Furring Assembly with Stand-off (Knife Plate) Shelf Angle & Brick Ties Supporting Brick Veneer – CLT and Wood Truss Floor Intersection

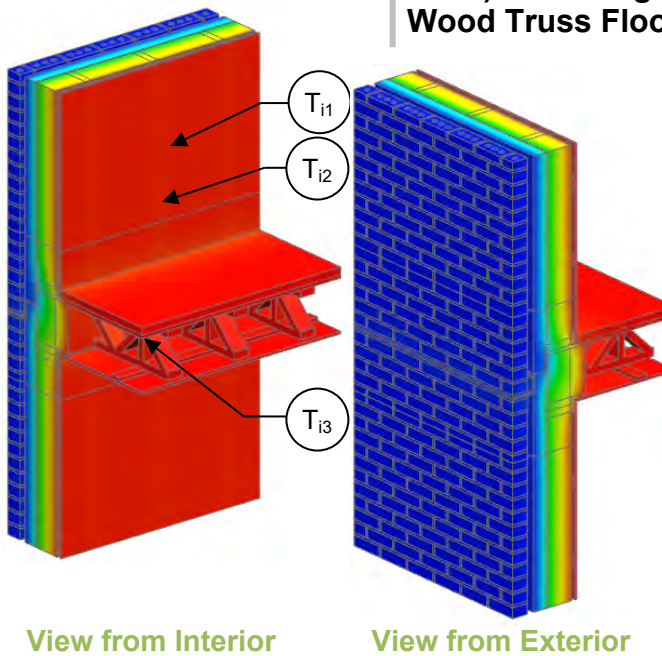

Thermal Performance Indicators

Assembly 1D (Nominal) R-Value	R _{1D}	R-23.4 (4.12 RSI) + exterior insulation
Transmittance / Resistance without Anomaly	U _o , R _o	"clear wall" U- and R-value, without floor
Transmittance / Resistance	U, R	U and R-values for the overall assembly
Surface Temperature Index ¹	T _i	0 = exterior temperature 1 = interior temperature
Linear Transmittance	ψ	Incremental increase in transmittance per linear length of wood framed floor

¹Assumptions and limitations for surface temperatures identified in ASHRAE 1365-RP

Nominal (1D) vs. Assembly Performance Indicators

Exterior Insulation 1D R-Value (RSI)	R _{1D} ft ² ·hr·°F / Btu (m ² K / W)	R _o ft ² ·hr·°F / Btu (m ² K / W)	U _o Btu/ft ² ·hr ·°F (W/m ² K)	R ft ² ·hr·°F / Btu (m ² K / W)	U Btu/ft ² ·hr ·°F (W/m ² K)	ψ Btu/ft ·hr·°F (W/m K)
R-5 (0.88)	R-28.4 (5.00)	R-26.2 (4.62)	0.038 (0.22)	R-23.7 (4.18)	0.042 (0.24)	0.031 (0.054)
R-10 (1.76)	R-33.4 (5.88)	R-30.3 (5.34)	0.033 (0.19)	R-27.0 (4.75)	0.037 (0.21)	0.032 (0.056)
R-15 (2.64)	R-38.4 (6.76)	R-34.0 (5.99)	0.029 (0.17)	R-29.7 (5.23)	0.034 (0.19)	0.033 (0.057)
R-20 (3.52)	R-43.4 (7.64)	R-37.4 (6.58)	0.027 (0.15)	R-32.1 (5.66)	0.031 (0.18)	0.034 (0.059)
R-25 (4.40)	R-48.4 (8.52)	R-40.5 (7.12)	0.025 (0.14)	R-34.3 (6.04)	0.029 (0.17)	0.035 (0.060)
R-30 (5.28)	R-53.4 (9.40)	R-43.4 (7.65)	0.023 (0.13)	R-36.3 (6.39)	0.028 (0.16)	0.035 (0.061)

Temperature Indices

	R5	R10	R15	R20	R25	R30	
T _{i1}	0.21	0.26	0.30	0.33	0.36	0.39	Min T on sheathing, at studs near brick ties
T _{i2}	0.30	0.41	0.48	0.53	0.56	0.60	Max T on sheathing, at studs, between brick ties
T _{i3}	0.43	0.46	0.47	0.49	0.50	0.51	Min T on CLT, near wood joists, behind shelf angle fasteners

Detail 8.2.16

Exterior Insulated 2x6 Wood Stud (16" o.c.) Wall with Interior Wood Furring Assembly with Stand-off (Knife Plate) Shelf Angle & Brick Ties Supporting Brick Veneer – CLT and Wood Truss Floor Intersection

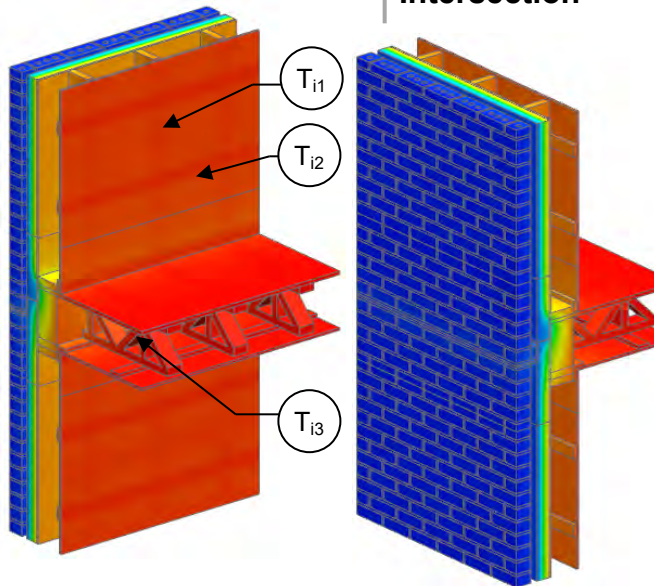

Thermal Performance Indicators

Assembly 1D (Nominal) R-Value	R _{1D}	R-4.0 (0.70 RSI) + exterior insulation
Transmittance / Resistance without Anomaly	U _o , R _o	"clear wall" U- and R-value, without floor
Transmittance / Resistance	U, R	U and R-values for the overall assembly
Surface Temperature Index ¹	T _i	0 = exterior temperature 1 = interior temperature
Linear Transmittance	ψ	Incremental increase in transmittance per linear length of wood framed floor

¹Assumptions and limitations for surface temperatures identified in ASHRAE 1365-RP

View from Interior

View from Exterior

Nominal (1D) vs. Assembly Performance Indicators

Exterior Insulation 1D R-Value (RSI)	R _{1D} ft ² ·hr·°F / Btu (m ² K / W)	R _o ft ² ·hr·°F / Btu (m ² K / W)	U _o Btu/ft ² ·hr ·°F (W/m ² K)	R ft ² ·hr·°F / Btu (m ² K / W)	U Btu/ft ² ·hr ·°F (W/m ² K)	ψ Btu/ft ·hr·°F (W/m K)
R-10 (1.76)	R-14.0 (2.46)	R-13.0 (2.29)	0.077 (0.44)	R-12.8 (2.25)	0.078 (0.44)	0.012 (0.021)
R-15 (2.64)	R-19.0 (3.35)	R-16.6 (2.92)	0.060 (0.34)	R-15.7 (2.77)	0.064 (0.36)	0.026 (0.046)
R-20 (3.52)	R-24.0 (4.23)	R-19.8 (3.49)	0.050 (0.29)	R-18.2 (3.21)	0.055 (0.31)	0.034 (0.059)
R-25 (4.40)	R-29.0 (5.11)	R-22.8 (4.02)	0.044 (0.25)	R-20.5 (3.61)	0.049 (0.28)	0.039 (0.068)
R-30 (5.28)	R-34.0 (5.99)	R-25.6 (4.50)	0.039 (0.22)	R-22.5 (3.96)	0.044 (0.25)	0.042 (0.073)

Temperature Indices

	R10	R15	R20	R25	R30	
T _{i1}	0.69	0.72	0.74	0.76	0.78	Min T on sheathing, at studs near brick ties
T _{i2}	0.84	0.87	0.90	0.91	0.92	Max T on sheathing, between studs and brick ties
T _{i3}	0.90	0.90	0.91	0.91	0.92	Min T on CLT, near wood joists, behind shelf angle fasteners

Detail 8.2.17

Exterior and Interior Insulated 2x6 Wood Stud (16" o.c.) Wall with Interior Wood Furring Assembly with Stand-off (Knife Plate) Shelf Angle & Brick Ties Supporting Brick Veneer – CLT and Wood Truss Floor Intersection

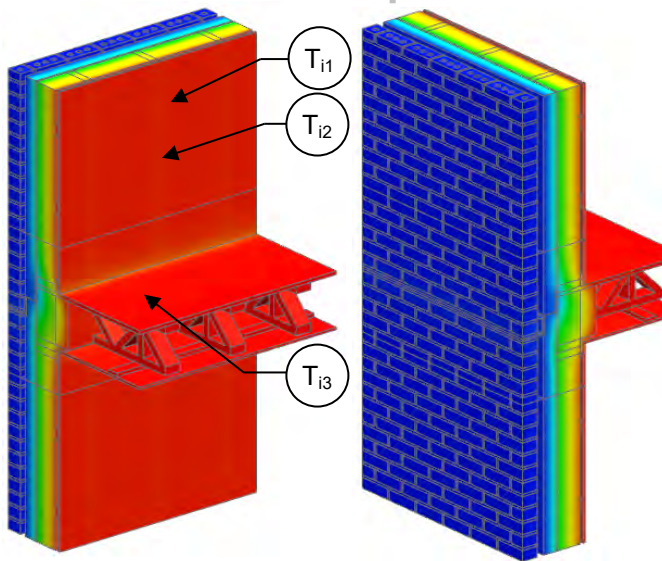

View from Interior

View from Exterior

Thermal Performance Indicators

Assembly 1D (Nominal) R-Value	R _{1D}	R-23.0 (4.05 RSI) + exterior insulation
Transmittance / Resistance without Anomaly	U _o , R _o	"clear wall" U- and R-value, without floor
Transmittance / Resistance	U, R	U and R-values for the overall assembly
Surface Temperature Index ¹	T _i	0 = exterior temperature 1 = interior temperature
Linear Transmittance	ψ	Incremental increase in transmittance per linear length of wood framed floor

¹Assumptions and limitations for surface temperatures identified in ASHRAE 1365-RP

Nominal (1D) vs. Assembly Performance Indicators

Exterior Insulation 1D R-Value (RSI)	R _{1D} ft ² ·hr·°F / Btu (m ² K / W)	R _o ft ² ·hr·°F / Btu (m ² K / W)	U _o Btu/ft ² ·hr ·°F (W/m ² K)	R ft ² ·hr·°F / Btu (m ² K / W)	U Btu/ft ² ·hr ·°F (W/m ² K)	ψ Btu/ft ·hr·°F (W/m K)
R-5 (0.88)	R-28.0 (4.93)	R-25.8 (4.54)	0.039 (0.22)	R-23.6 (4.15)	0.042 (0.24)	0.029 (0.050)
R-10 (1.76)	R-33.0 (5.81)	R-29.8 (5.26)	0.034 (0.19)	R-26.8 (4.72)	0.037 (0.21)	0.030 (0.052)
R-15 (2.64)	R-38.0 (6.69)	R-33.5 (5.91)	0.030 (0.17)	R-29.6 (5.21)	0.034 (0.19)	0.031 (0.054)
R-20 (3.52)	R-43.0 (7.57)	R-36.9 (6.50)	0.027 (0.15)	R-32.1 (5.65)	0.031 (0.18)	0.032 (0.055)
R-25 (4.40)	R-48.0 (8.45)	R-40.0 (7.05)	0.025 (0.14)	R-34.3 (6.04)	0.029 (0.17)	0.033 (0.057)
R-30 (5.28)	R-53.0 (9.33)	R-42.9 (7.56)	0.023 (0.13)	R-36.3 (6.39)	0.028 (0.16)	0.033 (0.058)

Temperature Indices

	R5	R10	R15	R20	R25	R30	
T _{i1}	0.21	0.26	0.30	0.33	0.37	0.39	Min T on sheathing, at studs near brick ties
T _{i2}	0.31	0.42	0.48	0.53	0.57	0.61	Max T on sheathing, at studs, between brick ties
T _{i3}	0.46	0.48	0.49	0.51	0.52	0.53	Min T on CLT, near wood joists, behind shelf angle fasteners

Detail 8.2.18

Exterior and Interior Insulated 2x6 Wood Stud (8" o.c.) Wall Assembly with Wood Strapping and Continuous Insulation Supporting Rainscreen Fiber Cement Board and R-19 Batt Insulation in Stud Cavity – Intermediate Floor Intersection

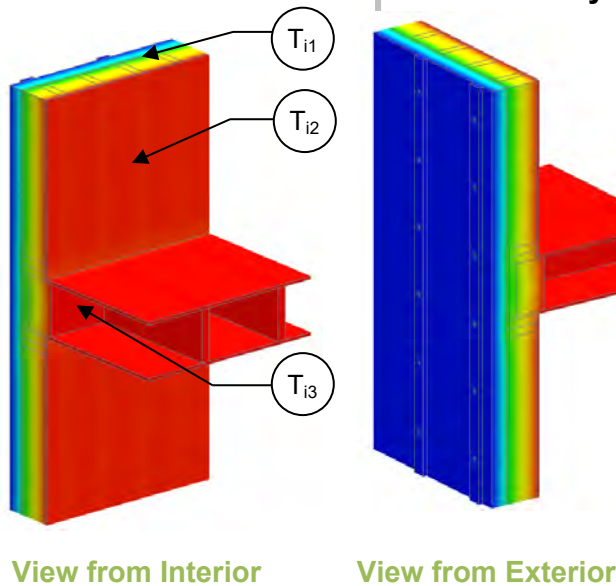

Thermal Performance Indicators

Assembly 1D (Nominal) R-Value	R_{1D}	R-21.5 (3.80 RSI) + exterior insulation
Transmittance / Resistance without Anomaly	U_o, R_o	"clear wall" U- and R-value, without floor
Transmittance / Resistance	U, R	U and R-values for the overall assembly
Surface Temperature Index ¹	T_i	0 = exterior temperature 1 = interior temperature
Linear Transmittance	ψ	Incremental increase in transmittance per linear length of wood framed floor

¹Assumptions and limitations for surface temperatures identified in ASHRAE 1365-RP

Nominal (1D) vs. Assembly Performance Indicators

Exterior Insulation 1D R-Value (RSI)	R_{1D} ft ² ·hr·°F / Btu (m ² K / W)	R_o ft ² ·hr·°F / Btu (m ² K / W)	U_o Btu/ft ² ·hr ·°F (W/m ² K)	R ft ² ·hr·°F / Btu (m ² K / W)	U Btu/ft ² ·hr ·°F (W/m ² K)	ψ Btu/ft ·hr·°F (W/m K)
R-0.0 (0.00)	R-21.5 (3.80)	R-18.1 (3.19)	0.055 (0.31)	R-17.5 (3.08)	0.057 (0.32)	0.018 (0.032)
R-5.0 (0.88)	R-26.5 (4.68)	R-23.1 (4.07)	0.043 (0.25)	R-22.6 (3.97)	0.044 (0.25)	0.011 (0.018)
R-15.0 (2.64)	R-36.5 (6.44)	R-32.6 (5.75)	0.031 (0.17)	R-32.1 (5.66)	0.031 (0.18)	0.005 (0.008)

Temperature Indices

	R0	R5	R15	
T_{i1}	0.07	0.26	0.48	Min T on sheathing, between studs at centre of stud cavity
T_{i2}	0.14	0.31	0.53	Max T on sheathing, at studs, between fasteners
T_{i3}	0.20	0.38	0.58	Min T on rim joist, between floor joists

Detail 8.2.19

Exterior and Interior Insulated 2x6 Wood Stud (16" o.c.) Wall Assembly with Wood Strapping and Continuous Insulation Supporting Rainscreen Fiber Cement Board and R-19 Batt Insulation in Stud Cavity – Intermediate Floor Intersection

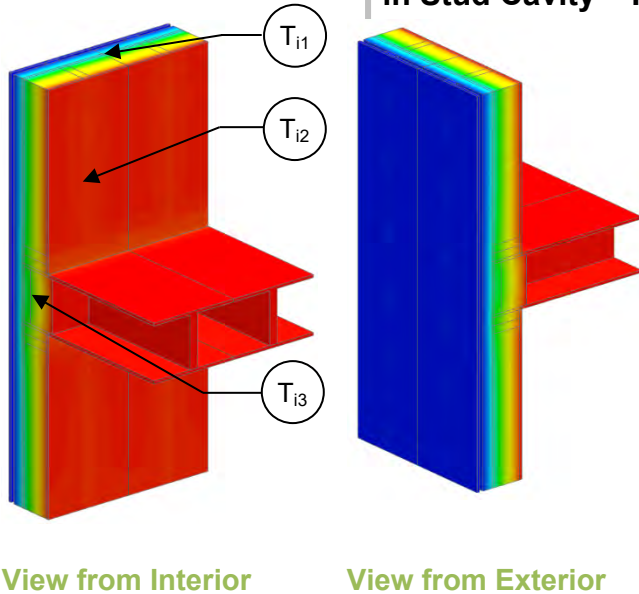

Thermal Performance Indicators

Assembly 1D (Nominal) R-Value	R _{1D}	R-21.5 (3.80 RSI) + exterior insulation
Transmittance / Resistance without Anomaly	U _o , R _o	"clear wall" U- and R-value, without floor
Transmittance / Resistance	U, R	U and R-values for the overall assembly
Surface Temperature Index ¹	T _i	0 = exterior temperature 1 = interior temperature
Linear Transmittance	ψ	Incremental increase in transmittance per linear length of wood framed floor

¹Assumptions and limitations for surface temperatures identified in ASHRAE 1365-RP

Nominal (1D) vs. Assembly Performance Indicators

Exterior Insulation 1D R-Value (RSI)	R _{1D} ft ² ·hr·°F / Btu (m ² K / W)	R _o ft ² ·hr·°F / Btu (m ² K / W)	U _o Btu/ft ² ·hr·°F (W/m ² K)	R ft ² ·hr·°F / Btu (m ² K / W)	U Btu/ft ² ·hr·°F (W/m ² K)	ψ Btu/ft·hr·°F (W/m K)
R-5 (0.88)	R-26.6 (4.68)	R-24.6 (4.33)	0.041 (0.23)	R-23.4 (4.12)	0.043 (0.24)	0.020 (0.034)
R-10 (1.76)	R-31.6 (5.57)	R-29.2 (5.14)	0.034 (0.19)	R-27.9 (4.91)	0.036 (0.20)	0.016 (0.027)
R-15 (2.64)	R-36.6 (6.45)	R-33.7 (5.93)	0.030 (0.17)	R-32.8 (5.78)	0.030 (0.17)	0.007 (0.012)

Temperature Indices

	R5	R10	R15	
T _{i1}	0.26	0.37	0.46	Min T on sheathing, between studs at centre of stud cavity
T _{i2}	0.31	0.42	0.53	Max T on sheathing, at studs, between fasteners
T _{i3}	0.38	0.49	0.57	Min T on rim joist, between floor joists

Detail 8.3.1

Exterior and Interior Insulated 2x6 Wood Stud (16" o.c.) Wall Assembly with Wood Strapping and Continuous Insulation Supporting Rainscreen Fiber Cement Board – Vinyl Window Intersection

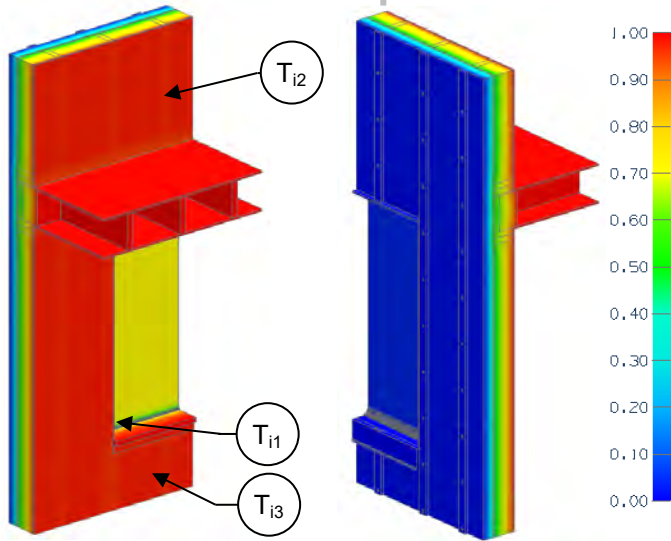

View from Interior View from Exterior

Base Assembly – Glazing

$U_{\text{centre of glass}}$ Btu/ft ² · hr · °F (W/m ² K)	U_g Btu/ft ² · hr · °F (W/m ² K)
0.321 (1.82)	0.331 (1.88)

Thermal Performance Indicators

Assembly 1D (Nominal) R-Value	R_{1D}	R-21.5 (3.80 RSI) + exterior insulation
Transmittance / Resistance without Anomaly	$U_w,$ $R_{w},$ $U_g,$	“clear wall” U- and R-value: w = wall without intermediate floor g = glazing
Transmittance / Resistance	$U_{\text{floor}},$ $R_{\text{floor}},$ $U_t,$ R_t	U and R-values for: floor = wall + intermediate floor t = combined wall + floor + window
Surface Temperature Index ¹	T_i	0 = exterior temperature 1 = interior temperature
Linear Transmittance	ψ	Incremental increase in transmittance per linear length

¹Assumptions and limitations for surface temperatures identified in ASHRAE 1365-RP

Nominal (1D) vs. Assembly Performance Indicators

Base Assembly – Wood Stud Clear Wall

Exterior Insulation 1D R-Value (RSI)	R_{1D} ft ² ·hr·°F / Btu (m ² K / W)	R_w ft ² ·hr·°F / Btu (m ² K / W)	U_w Btu/ft ² · hr · °F (W/m ² K)
R-5.0 (0.88)	R-26.5 (4.68)	R-24.6 (4.32)	0.041 (0.23)
R-15.0 (2.64)	R-36.5 (6.44)	R-33.6 (5.92)	0.030 (0.17)

Intermediate Floor Linear Transmittance

R_{floor} ft ² ·hr·°F / Btu (m ² K / W)	U_{floor} Btu/ft ² · hr · °F (W/m ² K)	ψ_{floor} Btu/ft ² · hr · °F (W/m ² K)
R-23.4 (4.12)	0.043 (0.24)	0.020 (0.035)
R-32.8 (5.78)	0.031 (0.17)	0.007 (0.012)

Window Transition Transmittance

Exterior Insulation 1D R-Value (RSI)	R_t ft ² ·hr·°F / Btu (m ² K / W)	U_t Btu/ft ² · hr · °F (W/m ² K)	ψ_{Head} Btu/ft · hr · °F (W/m K)	ψ_{Sill} Btu/ft · hr · °F (W/m K)	ψ_{Jamb} Btu/ft · hr · °F (W/m K)	ψ_{Total} Btu/ft · hr · °F (W/m K)
R-5.0 (0.88)	R-8.2 (1.44)	0.122 (0.69)	0.025 (0.042)	0.035 (0.061)	0.028 (0.049)	0.032 (0.055)
R-15.0 (2.64)	R-8.8 (1.55)	0.114 (0.65)	0.036 (0.062)	0.035 (0.061)	0.029 (0.050)	0.035 (0.061)

Temperature Indices

	R5	R15	
T_{i1}	0.44	0.44	Min T on window frame, at bottom corner
T_{i2}	0.37	0.50	Max T on interior surface of sheathing
T_{i3}	0.25	0.44	Min T on interior surface sheathing

Detail 8.3.2

Exterior and Interior Insulated 2x6 Wood Stud (16" o.c.) Wall Assembly with Wood Strapping and Continuous Insulation Supporting Rainscreen Fiber Cement Board and R-19 Batt Insulation in Stud Cavity – Aluminum Window Intersection

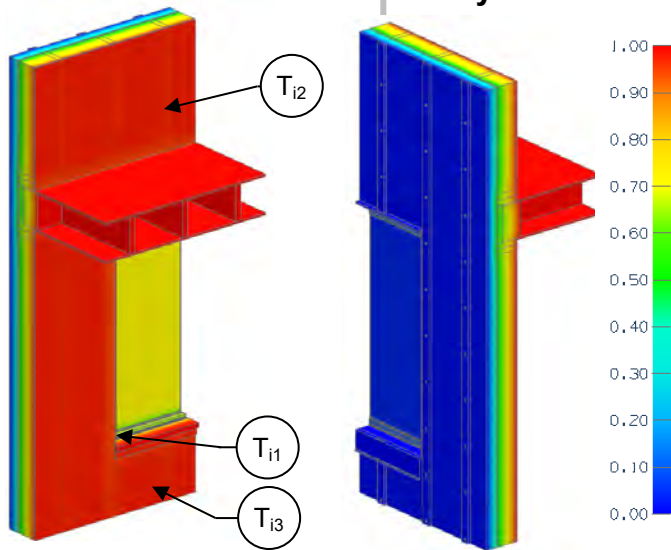

Thermal Performance Indicators

Assembly 1D (Nominal) R-Value	R_{1D}	R-21.5 (3.80 RSI) + exterior insulation
Transmittance / Resistance without Anomaly	U_w, R_w, U_g	“clear wall” U- and R-value: w = wall without intermediate floor, g = glazing
Transmittance / Resistance	$U_{floor}, R_{floor}, U_t, R_t$	U and R-values for: floor = wall + intermediate floor, t = combined wall + floor + window
Surface Temperature Index ¹	T_i	0 = exterior temperature, 1 = interior temperature
Linear Transmittance	Ψ	Incremental increase in transmittance per linear length

View from Interior
Base Assembly – Glazing

View from Exterior

$U_{\text{centre of glass}}$ Btu/ft ² · hr · °F (W/m ² K)	U_g Btu/ft ² · hr · °F (W/m ² K)
0.321 (1.82)	0.400 (2.27)

¹Assumptions and limitations for surface temperatures identified in ASHRAE 1365-RP

Nominal (1D) vs. Assembly Performance Indicators

Base Assembly – Wood Stud Clear Wall

Exterior Insulation 1D R-Value (RSI)	R_{1D} ft ² ·hr·°F / Btu (m ² K / W)	R_w ft ² ·hr·°F / Btu (m ² K / W)	U_w Btu/ft ² · hr · °F (W/m ² K)
R-0.0 (0.00)	R-21.5 (3.80)	R-19.7 (3.47)	0.051 (0.29)
R-5.0 (0.88)	R-26.5 (4.68)	R-24.6 (4.32)	0.041 (0.23)
R-15.0 (2.64)	R-36.5 (6.44)	R-33.6 (5.92)	0.030 (0.17)

Intermediate Floor Linear Transmittance

R_{floor} ft ² ·hr·°F / Btu (m ² K / W)	U_{floor} Btu/ft ² · hr · °F (W/m ² K)	Ψ_{floor} Btu/ft ² · hr · °F (W/m ² K)
R-17.0 (3.00)	0.059 (0.33)	0.070 (0.122)
R-23.4 (4.12)	0.043 (0.24)	0.020 (0.035)
R-32.8 (5.78)	0.031 (0.17)	0.007 (0.012)

Window Transition Transmittance

Exterior Insulation 1D R-Value (RSI)	R_t ft ² ·hr·°F / Btu (m ² K / W)	U_t Btu/ft ² · hr · °F (W/m ² K)	Ψ_{Head} Btu/ft · hr · °F (W/m K)	Ψ_{Sill} Btu/ft · hr · °F (W/m K)	Ψ_{Jamb} Btu/ft · hr · °F (W/m K)	Ψ_{Total} Btu/ft · hr · °F (W/m K)
R-0.0 (0.00)	R-6.9 (1.21)	0.146 (0.83)	-0.028 (-0.049)	0.016 (0.028)	0.028 (0.049)	0.001 (0.001)
R-5.0 (0.88)	R-7.3 (1.29)	0.136 (0.77)	0.016 (0.027)	0.011 (0.019)	0.025 (0.043)	0.017 (0.030)
R-15.0 (2.64)	R-7.8 (1.38)	0.128 (0.73)	0.029 (0.049)	0.012 (0.021)	0.026 (0.045)	0.022 (0.040)

Temperature Indices

	R0	R5	R15	
T_{i1}	0.62	0.63	0.58	Min T on window frame, at bottom corner
T_{i2}	0.12	0.33	0.49	Max T on interior surface of sheathing at studs
T_{i3}	0.07	0.25	0.43	Min T on interior surface sheathing between wood studs



Detail 8.3.3

Exterior and Interior Insulated 2x6 Wood Stud (8" o.c.) Wall Assembly with Wood Strapping and Continuous Insulation Supporting Rainscreen Fiber Cement Board – Vinyl Window Intersection

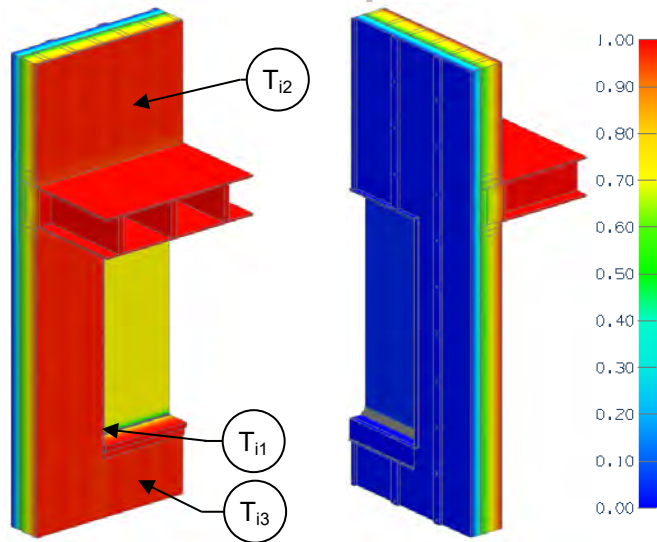

Thermal Performance Indicators

Assembly 1D (Nominal) R-Value	R_{1D}	R-21.5 (3.80 RSI) + exterior insulation
Transmittance / Resistance without Anomaly	U_w, R_w, U_g	“clear wall” U- and R-value: w = wall without intermediate floor g = glazing
Transmittance / Resistance	$U_{floor}, R_{floor}, U_t, R_t$	U and R-values for: floor = wall + intermediate floor t = combined wall + floor + window
Surface Temperature Index ¹	T_i	0 = exterior temperature 1 = interior temperature
Linear Transmittance	Ψ	Incremental increase in transmittance per linear length

View from Interior
Base Assembly – Glazing

View from Exterior

$U_{\text{centre of glass}}$ Btu/ft ² · hr · °F (W/m ² K)	U_g Btu/ft ² · hr · °F (W/m ² K)
0.321 (1.82)	0.331 (1.88)

¹Assumptions and limitations for surface temperatures identified in ASHRAE 1365-RP

Nominal (1D) vs. Assembly Performance Indicators

Base Assembly – Wood Stud Clear Wall

Exterior Insulation 1D R-Value (RSI)	R_{1D} ft ² ·hr·°F / Btu (m ² K / W)	R_w ft ² ·hr·°F / Btu (m ² K / W)	U_w Btu/ft ² · hr · °F (W/m ² K)
R-0.0 (0.00)	R-21.5 (3.80)	R-18.1 (3.19)	0.055 (0.31)
R-5.0 (0.88)	R-26.5 (4.68)	R-23.1 (4.07)	0.043 (0.25)
R-15.0 (2.64)	R-36.5 (6.44)	R-32.6 (5.75)	0.031 (0.17)

Intermediate Floor Linear Transmittance

R_{floor} ft ² ·hr·°F / Btu (m ² K / W)	U_{floor} Btu/ft ² · hr · °F (W/m ² K)	Ψ_{floor} Btu/ft ² · hr · °F (W/m ² K)
R-17.5 (3.08)	0.057 (0.32)	0.018 (0.032)
R-22.6 (3.97)	0.044 (0.25)	0.011 (0.018)
R-32.1 (5.66)	0.031 (0.18)	0.005 (0.008)

Window Transition Transmittance

Exterior Insulation 1D R-Value (RSI)	R_t ft ² ·hr·°F / Btu (m ² K / W)	U_t Btu/ft ² · hr · °F (W/m ² K)	Ψ_{Head} Btu/ft · hr · °F (W/m K)	Ψ_{Sill} Btu/ft · hr · °F (W/m K)	Ψ_{Jamb} Btu/ft · hr · °F (W/m K)	Ψ_{Total} Btu/ft · hr · °F (W/m K)
R-0.0 (0.00)	R-7.1 (1.25)	0.141 (0.80)	0.027 (0.046)	0.040 (0.069)	0.036 (0.062)	0.020 (0.035)
R-5.0 (0.88)	R-7.7 (1.35)	0.130 (0.74)	0.037 (0.065)	0.035 (0.061)	0.028 (0.049)	0.032 (0.056)
R-15.0 (2.64)	R-8.3 (1.46)	0.121 (0.69)	0.041 (0.071)	0.036 (0.062)	0.028 (0.049)	0.034 (0.058)

Temperature Indices

	R0	R5	R15	
T_{i1}	0.42	0.43	0.50	Min T on window frame, at bottom corner
T_{i2}	0.14	0.30	0.51	Max T on interior surface of sheathing at studs
T_{i3}	0.07	0.28	0.46	Min T on interior surface sheathing under sill between wood studs



Detail 8.3.4

Exterior Insulated 2x6 Wood Stud (16" o.c.) Wall Assembly with Wood Strapping and Continuous Insulation Supporting Rainscreen Fiber Cement Board – Triple Glazed Flange Mounted Vinyl Window Intersection with Window Positioned in Wood Framing

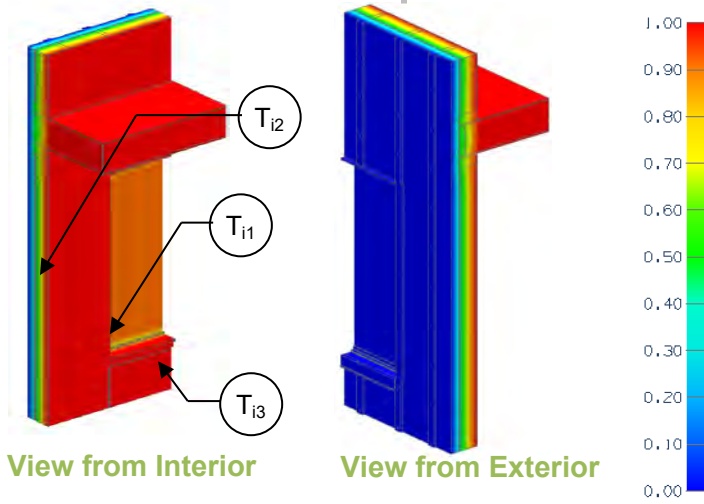

Thermal Performance Indicators

Assembly 1D (Nominal) R-Value	R_{1D}	R-3.2 (0.56 RSI) + exterior insulation
Transmittance / Resistance without Anomaly	U_w, R_w, U_g	“clear wall” U- and R-value: w = wall without floor g = glazing
Transmittance / Resistance	U_t, R_t	U and R-values for: t = combined wall + floor + window
Surface Temperature Index ¹	T_i	0 = exterior temperature 1 = interior temperature
Linear Transmittance	Ψ	Incremental increase in transmittance per linear length

¹Assumptions and limitations for surface temperatures identified in ASHRAE 1365-RP

Base Assembly – Glazing

$U_{\text{centre of glass}}$ Btu/ft ² · hr · °F (W/m ² K)	U_g Btu/ft ² · hr · °F (W/m ² K)
0.142 (0.81)	0.163 (0.92)

Nominal (1D) vs. Assembly Performance Indicators

Base Assembly – Wood Stud Clear Wall

Exterior Insulation 1D R-Value (RSI)	R_{1D} ft ² ·hr·°F / Btu (m ² K / W)	R_w ft ² ·hr·°F / Btu (m ² K / W)	U_w Btu/ft ² · hr · °F (W/m ² K)
R-5 (0.88)	R-8.2 (1.44)	R-8.5 (1.50)	0.117 (0.67)
R-10 (1.76)	R-13.2 (2.32)	R-12.9 (2.28)	0.077 (0.44)
R-15 (2.64)	R-18.2 (3.20)	R-17.1 (3.01)	0.059 (0.33)

Intermediate Floor Linear Transmittance

R_{floor} ft ² ·hr·°F / Btu (m ² K / W)	U_{floor} Btu/ft ² · hr · °F (W/m ² K)	Ψ_{floor} Btu/ft ² · hr · °F (W/m ² K)
R-8.7 (1.53)	0.115 (0.65)	-0.025 (-0.043)
R-13.2 (2.33)	0.076 (0.43)	-0.016 (-0.028)
R-18.2 (3.20)	0.055 (0.31)	-0.035 (-0.061)

Window Transition Transmittance

Exterior Insulation 1D R-Value (RSI)	R_t ft ² ·hr·°F / Btu (m ² K / W)	U_t Btu/ft ² · hr · °F (W/m ² K)	Ψ_{Head} Btu/ft · hr · °F (W/m K)	Ψ_{Sill} Btu/ft · hr · °F (W/m K)	Ψ_{Jamb} Btu/ft · hr · °F (W/m K)	Ψ_{Total} Btu/ft · hr · °F (W/m K)
R-5 (0.88)	R-7.9 (1.40)	0.126 (0.72)	-0.028 (-0.049)	0.003 (0.006)	0.008 (0.015)	0.000 (0.000)
R-10 (1.76)	R-10.0 (1.76)	0.100 (0.57)	0.000 (0.000)	0.013 (0.023)	0.015 (0.026)	0.014 (0.024)
R-15 (2.64)	R-11.4 (2.00)	0.088 (0.50)	0.035 (0.061)	0.019 (0.034)	0.021 (0.036)	0.032 (0.056)

Temperature Indices

	R5	R10	R15	
T_{i1}	0.65	0.66	0.66	Min T on window frame, at bottom corner
T_{i2}	0.75	0.84	0.88	Max T on interior surface of sheathing between studs
T_{i3}	0.62	0.70	0.72	Min T on interior surface sheathing below window sill adjacent to wood stud

Detail 8.3.5

Exterior and Interior Insulated 2x6 Wood Stud (16" o.c.) Wall Assembly with Wood Strapping and Continuous Insulation Supporting Rainscreen Fiber Cement Board and R-19 Batt Insulation in Stud Cavity – Triple Glazed Flange Mounted Vinyl Window Intersection with Window Positioned in Wood Framing

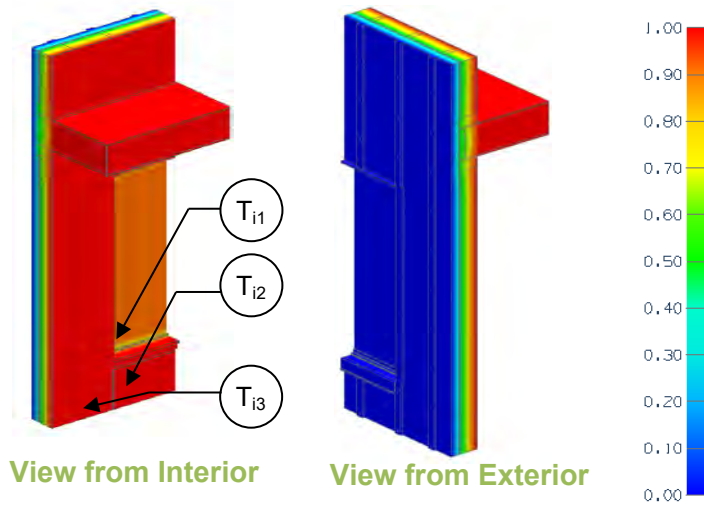

View from Interior View from Exterior

Base Assembly – Glazing

$U_{\text{centre of glass}}$ Btu/ft ² · hr · °F (W/m ² K)	U_g Btu/ft ² · hr · °F (W/m ² K)
0.142 (0.81)	0.163 (0.92)

Thermal Performance Indicators

Assembly 1D (Nominal) R-Value	R_{1D}	R-21.5 (3.80 RSI) + exterior insulation
Transmittance / Resistance without Anomaly	U_w, R_w, U_g	“clear wall” U- and R-value: w = wall without floor g = glazing
Transmittance / Resistance	U_t, R_t	U and R-values for: t = combined wall + floor + window
Surface Temperature Index ¹	T_i	0 = exterior temperature 1 = interior temperature
Linear Transmittance	Ψ	Incremental increase in transmittance per linear length

¹Assumptions and limitations for surface temperatures identified in ASHRAE 1365-RP

Nominal (1D) vs. Assembly Performance Indicators

Base Assembly – Wood Stud Clear Wall

Exterior Insulation 1D R-Value (RSI)	R_{1D} ft ² ·hr·°F / Btu (m ² K / W)	R_w ft ² ·hr·°F / Btu (m ² K / W)	U_w Btu/ft ² · hr · °F (W/m ² K)
R-5 (0.88)	R-26.5 (4.68)	R-24.6 (4.32)	0.041 (0.23)
R-10 (1.76)	R-31.5 (5.57)	R-29.2 (5.14)	0.034 (0.19)
R-15 (2.64)	R-36.5 (6.45)	R-33.6 (5.92)	0.030 (0.17)

Intermediate Floor Linear Transmittance

R_{floor} ft ² ·hr·°F / Btu (m ² K / W)	U_{floor} Btu/ft ² · hr · °F (W/m ² K)	Ψ_{floor} Btu/ft ² · hr · °F (W/m ² K)
R-23.4 (4.12)	0.043 (0.24)	0.020 (0.034)
R-27.9 (4.91)	0.036 (0.20)	0.016 (0.027)
R-32.8 (5.78)	0.030 (0.17)	0.007 (0.012)

Window Transition Transmittance

Exterior Insulation 1D R-Value (RSI)	R_t ft ² ·hr·°F / Btu (m ² K / W)	U_t Btu/ft ² · hr · °F (W/m ² K)	Ψ_{Head} Btu/ft · hr · °F (W/m K)	Ψ_{Sill} Btu/ft · hr · °F (W/m K)	Ψ_{Jamb} Btu/ft · hr · °F (W/m K)	Ψ_{Total} Btu/ft · hr · °F (W/m K)
R-5 (0.88)	R-13.0 (2.29)	0.077 (0.44)	0.023 (0.038)	0.015 (0.026)	0.019 (0.033)	0.018 (0.031)
R-10 (1.76)	R-14.0 (2.46)	0.071 (0.41)	0.021 (0.036)	0.015 (0.026)	0.020 (0.034)	0.018 (0.031)
R-15 (2.64)	R-14.7 (2.59)	0.068 (0.39)	0.027 (0.047)	0.016 (0.028)	0.021 (0.036)	0.022 (0.038)

Temperature Indices

	R5	R10	R15	
T_{11}	0.62	0.63	0.64	Min T on window frame, at bottom corner
T_{12}	0.33	0.43	0.49	Max T on interior surface of sheathing, below window adjacent to wood studs
T_{13}	0.25	0.35	0.41	Min T on interior surface of sheathing, adjacent to wood stud

Detail 8.3.6

Exterior Insulated 2x6 Wood Stud (16" o.c.) Wall Assembly with Wood Strapping (16" o.c.) and Continuous Insulation Supporting Rainscreen Fiber Cement Board – Triple Glazed High Performance Vinyl Window Intersection (Insulated Frames)

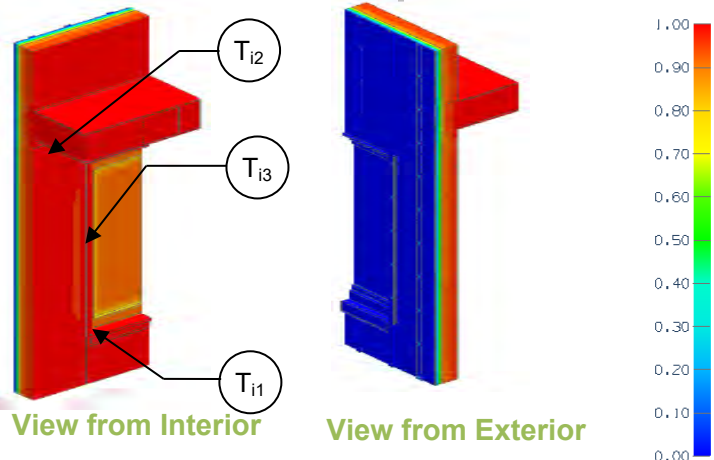

Thermal Performance Indicators

Assembly 1D (Nominal) R-Value	R_{1D}	R-3.5 (0.61 RSI) + exterior insulation
Transmittance / Resistance without Anomaly	U_w , R_w , U_g	"clear wall" U- and R-value: w = wall without floor g = glazing
Transmittance / Resistance	U_t , R_t	U and R-values for: t = combined wall + floor + window
Surface Temperature Index ¹	T_i	0 = exterior temperature 1 = interior temperature
Linear Transmittance	ψ	Incremental increase in transmittance per linear length

¹Assumptions and limitations for surface temperatures identified in ASHRAE 1365-RP

View from Interior

View from Exterior

Scenario

Scenario	Insulation Brought into Opening
A	No
B	Yes

Base Assembly – Glazing

$U_{\text{centre of glass}}$ Btu/ft ² · hr · °F (W/m ² K)	U_g Btu/ft ² · hr · °F (W/m ² K)
0.142 (0.81)	0.182 (1.03)

Nominal (1D) vs. Assembly Performance Indicators

Base Assembly – Wood Stud Clear Wall

Exterior Insulation 1D R-Value (RSI)	R_{1D} ft ² ·hr·°F / Btu (m ² K / W)	R_w ft ² ·hr·°F / Btu (m ² K / W)	U_w Btu/ft ² · hr · °F (W/m ² K)
R-5 (0.88)	R-8.2 (1.44)	R-8.5 (1.50)	0.117 (0.67)
R-10 (1.76)	R-13.2 (2.32)	R-13.0 (2.28)	0.077 (0.44)
R-15 (2.64)	R-18.2 (3.20)	R-17.1 (3.01)	0.058 (0.33)

Intermediate Floor Linear Transmittance

R_{floor} ft ² ·hr·°F / Btu (m ² K / W)	U_{floor} Btu/ft ² · hr · °F (W/m ² K)	ψ_{floor} Btu/ft ² · hr · °F (W/m ² K)
R-8.7 (1.53)	0.115 (0.65)	-0.025 (-0.044)
R-13.2 (2.33)	0.076 (0.43)	-0.016 (-0.027)
R-18.2 (3.20)	0.055 (0.31)	-0.008 (-0.014)

Window Transition Transmittance

	Exterior Insulation 1D R-Value (RSI)	R_t ft ² ·hr·°F / Btu (m ² K / W)	U_t Btu/ft ² · hr · °F (W/m ² K)	ψ_{Head} Btu/ft · hr · °F (W/m K)	ψ_{Sill} Btu/ft · hr · °F (W/m K)	ψ_{Jamb} Btu/ft · hr · °F (W/m K)	ψ_{Total} Btu/ft · hr · °F (W/m K)
A	R-5 (0.88)	R-7.9 (1.39)	0.127 (0.72)	-0.017 (-0.029)	0.006(0.011)	0.007 (0.012)	-0.016 (-0.027)
	R-10 (1.76)	R-9.9 (1.75)	0.101 (0.57)	0.006 (0.011)	0.016 (0.027)	0.016 (0.028)	-0.001 (-0.002)
	R-15 (2.64)	R-11.0 (1.94)	0.091 (0.52)	0.021 (0.036)	0.027 (0.046)	0.027 (0.047)	0.014 (0.024)
B	R-5 (0.88)	R-7.9 (1.39)	0.126 (0.72)	-0.047 (-0.081)	0.001 (0.001)	0.003 (0.005)	-0.019 (-0.033)
	R-10 (1.76)	R-10.0 (1.76)	0.100 (0.57)	-0.040 (-0.070)	0.010 (0.017)	0.012 (0.020)	-0.005 (-0.008)
	R-15 (2.64)	R-11.1 (1.96)	0.090 (0.51)	0.008 (0.013)	0.021 (0.036)	0.023 (0.039)	0.010 (0.017)

Temperature Indices

	R5	R10	R15	
T_{i1}	0.69	0.69	0.69	Min T on window frame, at bottom corner at edge of glazing
T_{i2}	0.33	0.45	0.53	Max T on interior surface of sheathing, below floor adjacent to wood stud
T_{i3}	0.25	0.30	0.33	Min T on interior surface of sheathing at centre of wall between wood stud



Detail 8.3.7

Exterior and Interior Insulated 2x6 Wood Stud (16" o.c.) Wall Assembly with Wood Strapping (16" o.c.) and Continuous Insulation Supporting Rainscreen Fiber Cement Board and R-19 Batt Insulation in Stud Cavity – Triple Glazed High Performance Vinyl Window Intersection (Insulated Frames)

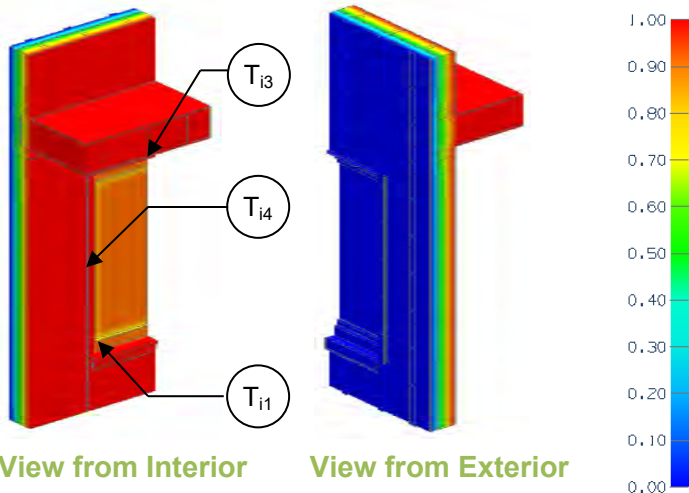

Thermal Performance Indicators

Assembly 1D (Nominal) R-Value	R_{1D}	R-21.5 (3.80 RSI) + exterior insulation
Transmittance / Resistance without Anomaly	U_w , R_w , U_g	"clear wall" U- and R-value: w = wall without floor, g = glazing
Transmittance / Resistance	U_t , R_t	U and R-values for: t = combined wall + floor + window
Surface Temperature Index ¹	T_i	0 = exterior temperature, 1 = interior temperature
Linear Transmittance	Ψ	Incremental increase in transmittance per linear length

Scenario

Scenario	Insulation Brought into Opening
A	No
B	Yes

Base Assembly – Glazing

$U_{\text{centre of glass}}$ Btu/ft ² · hr · °F (W/m ² K)	U_g Btu/ft ² · hr · °F (W/m ² K)
0.142 (0.81)	0.182 (1.03)

¹Assumptions and limitations for surface temperatures identified in ASHRAE 1365-RP

Nominal (1D) vs. Assembly Performance Indicators

Base Assembly – Wood Stud Clear Wall

Exterior Insulation 1D R-Value (RSI)	R_{1D} ft ² ·hr·°F / Btu (m ² K / W)	R_w ft ² ·hr·°F / Btu (m ² K / W)	U_w Btu/ft ² · hr · °F (W/m ² K)
R-5 (0.88)	R-26.5 (4.68)	R-24.6 (4.33)	0.041 (0.23)
R-10 (1.76)	R-31.5 (5.57)	R-29.2 (5.14)	0.034 (0.20)
R-15 (2.64)	R-36.5 (6.45)	R-33.6 (5.93)	0.030 (0.17)

Intermediate Floor Linear Transmittance

R_{floor} ft ² ·hr·°F / Btu (m ² K / W)	U_{floor} Btu/ft ² · hr · °F (W/m ² K)	Ψ_{floor} Btu/ft ² · hr · °F (W/m ² K)
R-23.4 (4.12)	0.043 (0.24)	0.020 (0.035)
R-27.9 (4.91)	0.036 (0.20)	0.016 (0.027)
R-32.8 (5.78)	0.030 (0.17)	0.007 (0.012)

Window Transition Transmittance

	Exterior Insulation 1D R-Value (RSI)	R_t ft ² ·hr·°F / Btu (m ² K / W)	U_t Btu/ft ² · hr · °F (W/m ² K)	Ψ_{Head} Btu/ft · hr · °F (W/m K)	Ψ_{Sill} Btu/ft · hr · °F (W/m K)	Ψ_{Jamb} Btu/ft · hr · °F (W/m K)	Ψ_{Total} Btu/ft · hr · °F (W/m K)
A	R-5 (0.88)	R-12.5 (2.19)	0.080 (0.46)	0.034 (0.059)	0.019 (0.032)	0.018 (0.032)	0.015 (0.026)
	R-10 (1.76)	R-13.4 (2.35)	0.075 (0.43)	0.028 (0.049)	0.020 (0.035)	0.018 (0.031)	0.014 (0.025)
	R-15 (2.64)	R-14.1 (2.48)	0.071 (0.40)	0.026 (0.044)	0.021 (0.036)	0.018 (0.032)	0.016 (0.028)
B	R-5 (0.88)	R-12.6 (2.21)	0.080 (0.45)	0.032 (0.056)	0.019 (0.033)	0.017 (0.029)	0.012 (0.021)
	R-10 (1.76)	R-13.5 (2.38)	0.074 (0.42)	0.026 (0.045)	0.015 (0.026)	0.016 (0.028)	0.011 (0.019)
	R-15 (2.64)	R-14.2 (2.51)	0.070 (0.40)	0.023 (0.041)	0.015 (0.026)	0.017 (0.029)	0.013 (0.022)

Temperature Indices

	R5	R10	R15	
T_{i1}	0.69	0.69	0.69	Min T on window frame, at bottom corner at edge of glazing
T_{i2}	0.75	0.84	0.88	Max T on interior surface of sheathing, at centre of wall away from wood studs
T_{i3}	0.63	0.71	0.77	Min T on interior surface of sheathing, below window sill adjacent to wood stud



Detail 8.3.8

Interior Insulated Cross Laminated Timber (CLT) Spandrel at Window and Dowel Laminated Timber (DLT) – Intermediate Floor Intersection with Edge of Floor and Glulam Beam Aligned

Thermal Performance Indicators

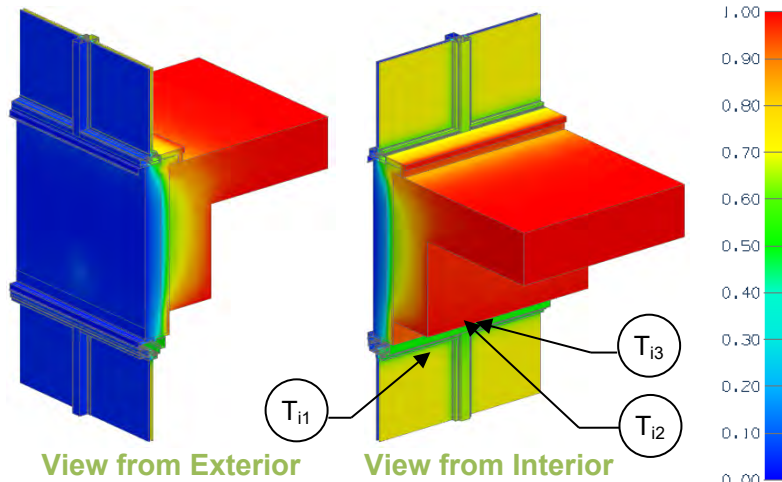

Assembly 1D (Nominal) R-Value at Beam	R_{1D}	R-15.4 (2.71 RSI) + insulation
Transmittance without Anomaly	$U_{g \text{ top}}$ $U_{g \text{ bottom}}$ U_g	U-value for aluminum window including framing g top = sill g bottom = head g = combined sill + head
Transmittance / Resistance	U_o, R_o U_s, R_s U_t, R_t	U and R-values for o = spandrel with floor without glazing s = spandrel including window to wall interface t = combined glazing + spandrel
Linear Transmittance	ψ	Incremental increase in transmittance per linear length of window to wall interface

Assembly Performance Indicators

Base Assembly – Aluminum Window

Mullion Spacing	$U_{\text{centre of glass}}$ Btu/ft ² · hr · °F (W/m ² K)	$U_{g \text{ top}}$ Btu/ft ² · hr · °F (W/m ² K)	$U_{g \text{ bottom}}$ Btu/ft ² · hr · °F (W/m ² K)	U_g Btu/ft ² · hr · °F (W/m ² K)
24" o.c.	0.321 (1.82)	0.428 (2.43)	0.524 (2.97)	0.478 (2.71)
36" o.c.	0.321 (1.82)	0.407 (2.31)	0.462 (2.63)	0.436 (2.47)

Window to Wall Linear Transmittance

ISO-CONNECT Spacing	Spandrel Insulation 1D R-Value (RSI)	R_{1D} ft ² · hr · °F / Btu (m ² K / W)	R_o ft ² · hr · °F / Btu (m ² K / W)	U_o Btu/ft ² · hr · °F (W/m ² K)	R_s ft ² · hr · °F / Btu (m ² K / W)	U_s Btu/ft ² · hr · °F (W/m ² K)	R_t ft ² · hr · °F / Btu (m ² K / W)	U_t Btu/ft ² · hr · °F (W/m ² K)	ψ Btu/ft · hr · °F (W/m K)
24" o.c.	R-8.4 (1.48)	R-23.8 (4.18)	R-12.6 (2.22)	0.079 (0.45)	R-11.1 (1.95)	0.090 (0.51)	R-3.8 (0.68)	0.261 (1.48)	0.015 (0.026)
	R-16.8 (2.96)	R-32.2 (5.66)	R-15.0 (2.64)	0.067 (0.38)	R-12.7 (2.25)	0.078 (0.45)	R-3.9 (0.69)	0.254 (1.44)	0.015 (0.027)
	R-25.2 (4.44)	R-40.6 (7.14)	R-16.4 (2.89)	0.061 (0.35)	R-13.8 (2.43)	0.073 (0.41)	R-4.0 (0.70)	0.251 (1.42)	0.016 (0.027)
36" o.c.	R-8.4 (1.48)	R-23.8 (4.18)	R-13.0 (2.29)	0.077 (0.44)	R-12.3 (2.16)	0.081 (0.46)	R-3.7 (0.65)	0.271 (1.54)	0.006 (0.010)
	R-16.8 (2.96)	R-32.2 (5.66)	R-15.6 (2.76)	0.064 (0.36)	R-14.6 (2.58)	0.068 (0.39)	R-3.8 (0.67)	0.264 (1.50)	0.006 (0.010)
	R-25.2 (4.44)	R-40.6 (7.14)	R-17.3 (3.05)	0.058 (0.33)	R-16.0 (2.82)	0.062 (0.35)	R-3.8 (0.67)	0.262 (1.49)	0.006 (0.010)
	R-33.6 (5.92)	R-49.0 (8.62)	R-18.5 (3.25)	0.054 (0.31)	R-17.0 (3.00)	0.059 (0.33)	R-3.8 (0.68)	0.260 (1.48)	0.006 (0.010)

Temperature Indices

	24" o.c.			36" o.c.				
	R8.4	R16.8	R25.2	R8.4	R16.8	R25.2	R33.6	
T ₁	0.51	0.51	0.51	0.51	0.51	0.51	0.51	Min T on window glass, at top corner of window head
T ₂	0.52	0.52	0.52	0.53	0.53	0.53	0.53	Min T on window frame, on vertical mullion at deflection header
T ₃	0.90	0.93	0.94	0.89	0.93	0.94	0.95	Min T on beam, at plywood closure, along connector

Detail 8.3.9

Full Height Interior Insulated Cross Laminated Timber (CLT) Spandrel at Window and Dowel Laminated Timber (DLT) – Intermediate Floor Intersection with Edge of Floor and Glulam Beam Aligned

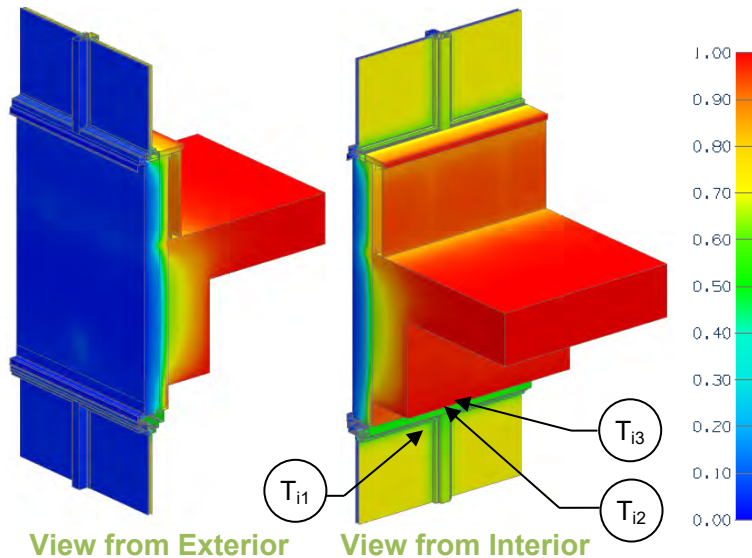

Thermal Performance Indicators

Assembly 1D (Nominal) R-Value at Beam	R_{1D}	R-15.4 (2.71 RSI) + insulation
Transmittance without Anomaly	$U_{g \text{ top}}$ $U_{g \text{ bottom}}$ U_g	U-value for aluminum window including framing g top = sill g bottom = head g = combined sill + head
Transmittance / Resistance	U_o, R_o U_s, R_s U_t, R_t	U and R-values for o = spandrel with floor without glazing s = spandrel including window to wall interface t = combined glazing + spandrel
Linear Transmittance	ψ	Incremental increase in transmittance per linear length of window to wall interface

Assembly Performance Indicators

Base Assembly – Aluminum Window

Mullion Spacing	$U_{\text{centre of glass}}$ Btu/ft ² ·hr·°F (W/m ² K)	$U_{g \text{ top}}$ Btu/ft ² ·hr·°F (W/m ² K)	$U_{g \text{ bottom}}$ Btu/ft ² ·hr·°F (W/m ² K)	U_g Btu/ft ² ·hr·°F (W/m ² K)
36" o.c.	0.321 (1.82)	0.407 (2.31)	0.462 (2.63)	0.436 (2.47)

Window to Wall Linear Transmittance

ISO-CONNECT Spacing	Spandrel Insulation 1D R-Value (RSI)	R_{1D} ft ² ·hr·°F / Btu (m ² K / W)	R_o ft ² ·hr·°F / Btu (m ² K / W)	U_o Btu/ft ² ·hr·°F (W/m ² K)	R_s ft ² ·hr·°F / Btu (m ² K / W)	U_s Btu/ft ² ·hr·°F (W/m ² K)	R_t ft ² ·hr·°F / Btu (m ² K / W)	U_t Btu/ft ² ·hr·°F (W/m ² K)	ψ Btu/ft ² ·hr·°F (W/m K)
36" o.c.	R-8.4 (1.48)	R-23.8 (4.18)	R-13.1 (2.31)	0.076 (0.43)	R-8.5 (1.50)	0.117 (0.67)	R-3.5 (0.61)	0.287 (1.63)	0.008 (0.014)
	R-16.8 (2.96)	R-32.2 (5.66)	R-16.6 (2.93)	0.060 (0.34)	R-10.8 (1.90)	0.093 (0.53)	R-3.6 (0.64)	0.276 (1.57)	0.007 (0.011)
	R-25.2 (4.44)	R-40.6 (7.14)	R-19.2 (3.38)	0.052 (0.30)	R-12.4 (2.19)	0.080 (0.46)	R-3.7 (0.65)	0.270 (1.53)	0.006 (0.010)
	R-33.6 (5.92)	R-49.0 (8.62)	R-21.2 (3.74)	0.047 (0.27)	R-13.7 (2.41)	0.073 (0.42)	R-3.7 (0.66)	0.267 (1.51)	0.006 (0.010)

Temperature Indices

	R-8.4	R-16.8	R-25.2	R-33.6	
T_{i1}	0.52	0.52	0.52	0.52	Min T on window glass, at top corner of window head
T_{i2}	0.53	0.53	0.53	0.53	Min T on window frame, on vertical mullion at deflection header
T_{i3}	0.89	0.92	0.94	0.95	Min T on beam, at plywood closure, along connector

Detail 8.3.10

Interior Insulated Cross Laminated Timber (CLT) Spandrel at Window and Dowel Laminated Timber (DLT) – Intermediate Floor Intersection with Edge of Floor and Glulam Beam Not Aligned

Thermal Performance Indicators

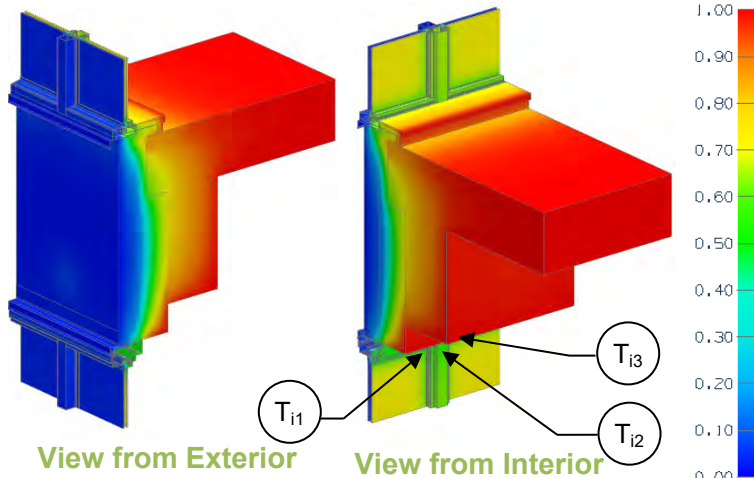

Assembly 1D (Nominal) R-Value at Beam	R_{1D}	R-40.6 (7.15 RSI)
Transmittance without Anomaly	$U_{g \text{ top}}$ $U_{g \text{ bottom}}$ U_g	U-value for aluminum window including framing g top = sill g bottom = head g = combined sill + head
Transmittance / Resistance	U_o, R_o U_s, R_s U_t, R_t	U and R-values for o = spandrel with floor without glazing s = spandrel including window to wall interface t = combined glazing + spandrel
Linear Transmittance	ψ	Incremental increase in transmittance per linear length of window to wall interface

Assembly Performance Indicators

Base Assembly – Aluminum Window

Mullion Spacing	$U_{\text{centre of glass}}$ Btu/ft ² · hr · °F (W/m ² K)	$U_{g \text{ top}}$ Btu/ft ² · hr · °F (W/m ² K)	$U_{g \text{ bottom}}$ Btu/ft ² · hr · °F (W/m ² K)	U_g Btu/ft ² · hr · °F (W/m ² K)
24" o.c.	0.321 (1.82)	0.428 (2.43)	0.524 (2.97)	0.478 (2.71)

Window to Wall Linear Transmittance

ISO-CONNECT Spacing	Floor Insulation 1D R-Value (RSI)	R_{1D} ft ² · hr · °F / Btu (m ² K / W)	R_o ft ² · hr · °F / Btu (m ² K / W)	U_o Btu/ft ² · hr · °F (W/m ² K)	R_s ft ² · hr · °F / Btu (m ² K / W)	U_s Btu/ft ² · hr · °F (W/m ² K)	R_t ft ² · hr · °F / Btu (m ² K / W)	U_t Btu/ft ² · hr · °F (W/m ² K)	ψ Btu/ft · hr · °F (W/m K)
24" o.c.	R-8.4 (1.48)	R-40.6 (7.15)	R-15.3 (2.69)	0.066 (0.37)	R-13.0 (2.30)	0.077 (0.44)	R-4.0 (0.70)	0.253 (1.44)	0.015 (0.026)
	R-12.6 (2.22)	R-40.6 (7.15)	R-15.8 (2.78)	0.063 (0.36)	R-13.5 (2.37)	0.074 (0.42)	R-4.0 (0.70)	0.252 (1.43)	0.015 (0.025)
	R-16.8 (2.96)	R-40.6 (7.15)	R-16.2 (2.85)	0.062 (0.35)	R-13.8 (2.44)	0.072 (0.41)	R-4.0 (0.70)	0.250 (1.42)	0.014 (0.024)

Temperature Indices

	R-8.4	R-16.8	R-33.6	
T_{i1}	0.51	0.51	0.51	Min T on window glass, at top corner of window head
T_{i2}	0.52	0.52	0.52	Min T on window frame, on vertical mullion at deflection header
T_{i3}	0.93	0.93	0.93	Min T on beam, at plywood closure, along connector

Detail 8.3.11

Double Framed Wall with 2x6 and 2x4 Wood Studs (16" o.c.) and 2" Gap – Triple Glazed Flanged Fiberglass Window Intersection with Wood Blocking and Un-insulated Perimeter

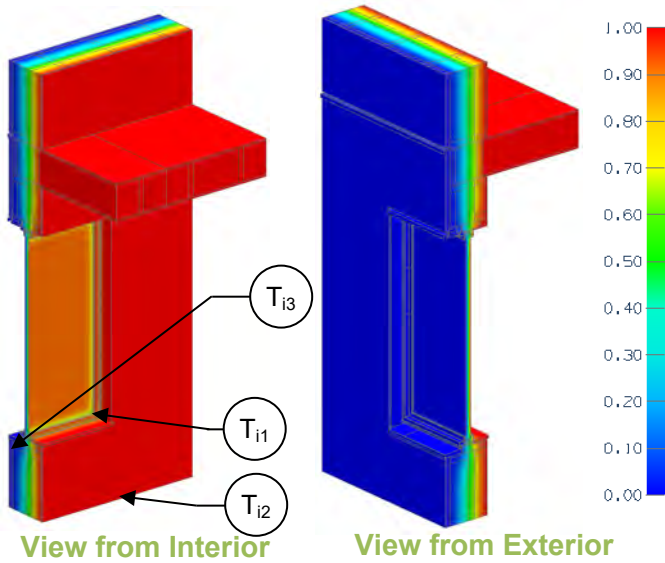

Thermal Performance Indicators

Assembly 1D (Nominal) R-Value	R_{1D}	R-2.5 (0.44 RSI) + insulation
Transmittance / Resistance without Anomaly	U_w, R_w, U_g	"clear wall" U- and R-value: w = wall without intermediate floor g = glazing
Transmittance / Resistance	$U_{floor}, R_{floor}, U_t, R_t$	U and R-values for: floor = wall + intermediate floor t = combined wall + floor + window
Surface Temperature Index ¹	T_i	0 = exterior temperature 1 = interior temperature
Linear Transmittance	ψ	Incremental increase in transmittance per linear length

Base Assembly – Glazing

$U_{\text{centre of glass}}$ Btu/ft ² · hr · °F (W/m ² K)	U_g Btu/ft ² · hr · °F (W/m ² K)
0.156 (0.888)	0.180 (1.020)

¹Assumptions and limitations for surface temperatures identified in ASHRAE 1365-RP

Nominal (1D) vs. Assembly Performance Indicators

Base Assembly – Wood Stud Clear Wall

Fill Insulation 1D R-Value (RSI)	R_{1D} ft ² ·hr·°F / Btu (m ² K / W)	R_w ft ² ·hr·°F / Btu (m ² K / W)	U_w Btu/ft ² · hr · °F (W/m ² K)
R-38.5 (6.78)	R-41.0 (7.23)	R-38.0 (6.70)	0.026 (0.15)
R-44.0 (7.75)	R-46.5 (8.19)	R-42.4 (7.47)	0.024 (0.13)
R-55.0 (9.69)	R-57.5 (10.13)	R-50.8 (8.94)	0.020 (0.11)
R-66.0 (11.62)	R-68.5 (12.07)	R-58.9 (10.37)	0.017 (0.10)

Intermediate Floor Linear Transmittance

R_{floor} ft ² ·hr·°F / Btu (m ² K / W)	U_{floor} Btu/ft ² · hr · °F (W/m ² K)	ψ_{floor} Btu/ft ² · hr · °F (W/m ² K)
R-36.4 (6.42)	0.027 (0.16)	0.010 (0.018)
R-40.1 (7.07)	0.025 (0.14)	0.012 (0.020)
R-47.2 (8.31)	0.021 (0.12)	0.013 (0.023)
R-53.7 (9.46)	0.019 (0.11)	0.014 (0.025)

Window Transition Transmittance

Fill Insulation 1D R-Value (RSI)	R_t ft ² ·hr·°F / Btu (m ² K / W)	U_t Btu/ft ² · hr · °F (W/m ² K)	ψ_{Head} Btu/ft · hr · °F (W/m K)	ψ_{Sill} Btu/ft · hr · °F (W/m K)	ψ_{Jamb} Btu/ft · hr · °F (W/m K)	ψ_{Total} Btu/ft · hr · °F (W/m K)
R-38.5 (6.78)	R-13.7 (2.41)	0.073 (0.42)	0.033 (0.057)	0.048 (0.083)	0.037 (0.064)	0.041 (0.072)
R-44.0 (7.75)	R-14.0 (2.46)	0.072 (0.41)	0.033 (0.057)	0.049 (0.084)	0.038 (0.066)	0.042 (0.073)
R-55.0 (9.69)	R-14.5 (2.55)	0.069 (0.39)	0.034 (0.059)	0.050 (0.086)	0.039 (0.068)	0.044 (0.075)
R-66.0 (11.62)	R-14.9 (2.62)	0.067 (0.38)	0.034 (0.060)	0.050 (0.087)	0.040 (0.069)	0.044 (0.077)

Temperature Indices

	R38.5	R44.0	R55.0	R66.0	
T_{i1}	0.66	0.66	0.66	0.66	Min T on window frame, at bottom corner
T_{i2}	0.07	0.07	0.07	0.06	Max T on interior surface of sheathing at studs
T_{i3}	0.01	0.01	0.01	0.01	Min T on interior surface sheathing below window sill between wood stud



Detail 8.3.12

Double Framed Wall with 2x6 and 2x4 Wood Studs (16" o.c.) and 3" Gap – Triple Glazed Flanged Fiberglass Window Intersection with Wood Blocking and Un-insulated Perimeter

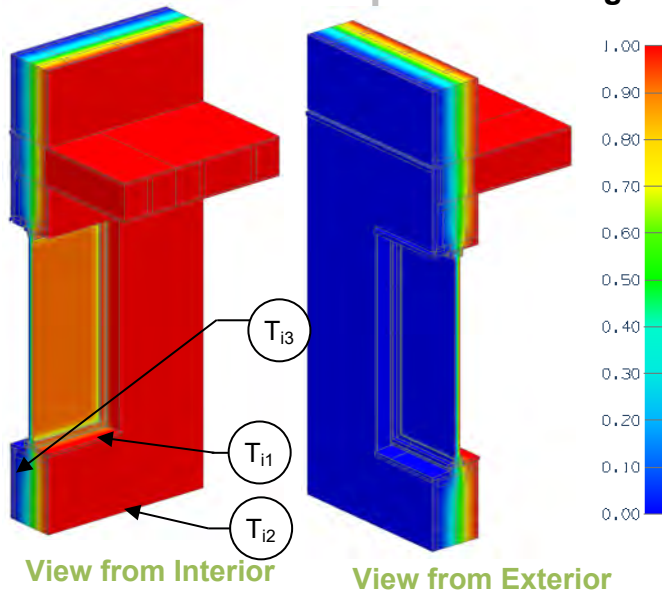

Thermal Performance Indicators

Assembly 1D (Nominal) R-Value	R_{1D}	R-2.5 (0.44 RSI) + insulation
Transmittance / Resistance without Anomaly	U_w, R_w, U_g	"clear wall" U- and R-value: w = wall without intermediate floor g = glazing
Transmittance / Resistance	$U_{floor}, R_{floor}, U_t, R_t$	U and R-values for: floor = wall + intermediate floor t = combined wall + floor + window
Surface Temperature Index ¹	T_i	0 = exterior temperature 1 = interior temperature
Linear Transmittance	Ψ	Incremental increase in transmittance per linear length

¹Assumptions and limitations for surface temperatures identified in ASHRAE 1365-RP

Base Assembly – Glazing

$U_{\text{centre of glass}}$ Btu/ft ² · hr · °F (W/m ² K)	U_g Btu/ft ² · hr · °F (W/m ² K)
0.156 (0.888)	0.180 (1.020)

Nominal (1D) vs. Assembly Performance Indicators

Base Assembly – Wood Stud Clear Wall

Fill Insulation 1D R-Value (RSI)	R_{1D} ft ² ·hr·°F / Btu (m ² K / W)	R_w ft ² ·hr·°F / Btu (m ² K / W)	U_w Btu/ft ² · hr · °F (W/m ² K)
R-42.0 (7.40)	R-44.5 (7.84)	R-41.6 (7.32)	0.024 (0.14)
R-48.0 (8.45)	R-50.5 (8.90)	R-46.4 (8.18)	0.022 (0.12)
R-60.0 (10.57)	R-62.5 (11.01)	R-55.9 (9.84)	0.018 (0.10)
R-72.0 (12.68)	R-74.5 (13.13)	R-65.0 (11.45)	0.015 (0.09)

Intermediate Floor Linear Transmittance

R_{floor} ft ² ·hr·°F / Btu (m ² K / W)	U_{floor} Btu/ft ² · hr · °F (W/m ² K)	Ψ_{floor} Btu/ft ² · hr · °F (W/m ² K)
R-39.9 (7.02)	0.025 (0.14)	0.009 (0.016)
R-44.1 (7.76)	0.023 (0.13)	0.010 (0.017)
R-52.1 (9.17)	0.019 (0.11)	0.011 (0.020)
R-59.6 (10.49)	0.017 (0.10)	0.012 (0.021)

Window Transition Transmittance

Fill Insulation 1D R-Value (RSI)	R_t ft ² ·hr·°F / Btu (m ² K / W)	U_t Btu/ft ² · hr · °F (W/m ² K)	Ψ_{Head} Btu/ft · hr · °F (W/m K)	Ψ_{Sill} Btu/ft · hr · °F (W/m K)	Ψ_{Jamb} Btu/ft · hr · °F (W/m K)	Ψ_{Total} Btu/ft · hr · °F (W/m K)
R-42.0 (7.40)	R-13.9 (2.46)	0.072 (0.41)	0.035 (0.060)	0.049 (0.084)	0.039 (0.067)	0.043 (0.074)
R-48.0 (8.45)	R-14.3 (2.51)	0.070 (0.40)	0.035 (0.061)	0.049 (0.085)	0.039 (0.068)	0.044 (0.075)
R-60.0 (10.57)	R-14.8 (2.61)	0.068 (0.38)	0.036 (0.062)	0.050 (0.087)	0.040 (0.070)	0.044 (0.077)
R-72.0 (12.68)	R-15.2 (2.67)	0.066 (0.37)	0.036 (0.063)	0.041 (0.088)	0.041 (0.071)	0.045 (0.078)

Temperature Indices

	R42.0	R48.0	R60.0	R72.0	
T_{i1}	0.66	0.66	0.66	0.66	Min T on window frame, at bottom corner
T_{i2}	0.07	0.06	0.06	0.05	Max T on interior surface of sheathing at studs
T_{i3}	0.01	0.01	0.01	0.01	Min T on interior surface sheathing below window sill between wood stud



Detail 8.3.13

Double Framed Wall with 2x6 and 2x4 Wood Studs (16" o.c.) and 4" Gap – Triple Glazed Flanged Fiberglass Window Intersection with Wood Blocking and Un-insulated Perimeter

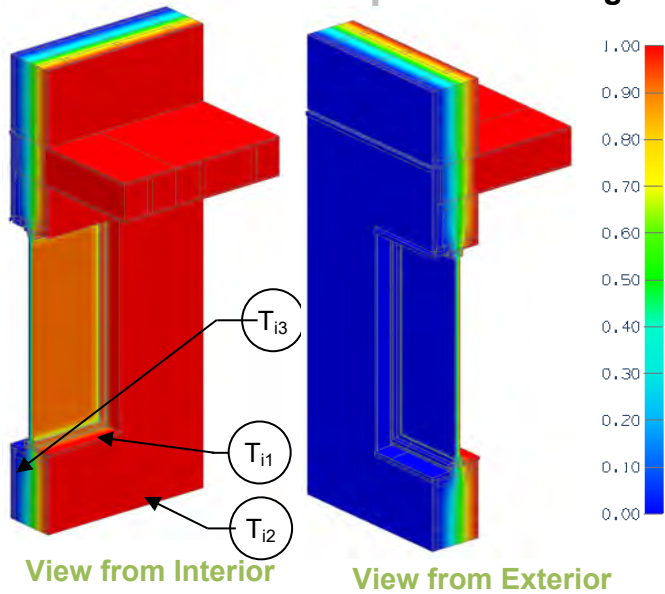

Thermal Performance Indicators

Assembly 1D (Nominal) R-Value	R_{1D}	R-2.5 (0.44 RSI) + insulation
Transmittance / Resistance without Anomaly	U_w, R_w, U_g	"clear wall" U- and R-value: w = wall without intermediate floor g = glazing
Transmittance / Resistance	$U_{floor}, R_{floor}, U_t, R_t$	U and R-values for: floor = wall + intermediate floor t = combined wall + floor + window
Surface Temperature Index ¹	T_i	0 = exterior temperature 1 = interior temperature
Linear Transmittance	Ψ	Incremental increase in transmittance per linear length

¹Assumptions and limitations for surface temperatures identified in ASHRAE 1365-RP

Base Assembly – Glazing

$U_{\text{centre of glass}}$ Btu/ft ² · hr · °F (W/m ² K)	U_g Btu/ft ² · hr · °F (W/m ² K)
0.156 (0.888)	0.180 (1.020)

Nominal (1D) vs. Assembly Performance Indicators

Base Assembly – Wood Stud Clear Wall

Fill Insulation 1D R-Value (RSI)	R_{1D} ft ² ·hr·°F / Btu (m ² K / W)	R_w ft ² ·hr·°F / Btu (m ² K / W)	U_w Btu/ft ² · hr · °F (W/m ² K)
R-45.5 (8.01)	R-48.0 (8.46)	R-45.1 (7.94)	0.022 (0.13)
R-52.0 (9.16)	R-54.5 (9.60)	R-50.5 (8.89)	0.020 (0.11)
R-65.0 (11.45)	R-67.5 (11.89)	R-60.9 (10.73)	0.016 (0.09)
R-78.0 (13.74)	R-80.5 (14.18)	R-71.1 (12.52)	0.014 (0.08)

Intermediate Floor Linear Transmittance

R_{floor} ft ² ·hr·°F / Btu (m ² K / W)	U_{floor} Btu/ft ² · hr · °F (W/m ² K)	Ψ_{floor} Btu/ft ² · hr · °F (W/m ² K)
R-43.3 (7.62)	0.023 (0.13)	0.008 (0.014)
R-48.0 (8.45)	0.021 (0.12)	0.009 (0.016)
R-56.9 (10.03)	0.018 (0.10)	0.010 (0.018)
R-65.3 (11.51)	0.015 (0.09)	0.011 (0.019)

Window Transition Transmittance

Fill Insulation 1D R-Value (RSI)	R_t ft ² ·hr·°F / Btu (m ² K / W)	U_t Btu/ft ² · hr · °F (W/m ² K)	Ψ_{Head} Btu/ft · hr · °F (W/m K)	Ψ_{Sill} Btu/ft · hr · °F (W/m K)	Ψ_{Jamb} Btu/ft · hr · °F (W/m K)	Ψ_{Total} Btu/ft · hr · °F (W/m K)
R-45.5 (8.01)	R-14.2 (2.50)	0.070 (0.40)	0.037 (0.063)	0.049 (0.085)	0.040 (0.069)	0.044 (0.076)
R-52.0 (9.16)	R-14.5 (2.56)	0.069 (0.39)	0.037 (0.064)	0.050 (0.086)	0.040 (0.070)	0.044 (0.077)
R-65.0 (11.45)	R-15.0 (2.65)	0.066 (0.38)	0.038 (0.065)	0.050 (0.087)	0.041 (0.071)	0.045 (0.078)
R-78.0 (13.74)	R-15.4 (2.71)	0.065 (0.37)	0.038 (0.066)	0.051 (0.088)	0.041 (0.072)	0.046 (0.079)

Temperature Indices

	R45.5	R52.0	R65.0	R78.0	
T_{i1}	0.66	0.66	0.66	0.66	Min T on window frame, at bottom corner
T_{i2}	0.06	0.06	0.05	0.05	Max T on interior surface of sheathing at studs
T_{i3}	0.01	0.01	0.01	0.01	Min T on interior surface sheathing below window sill between wood stud



Detail 8.3.14

Double Framed Wall with 2x6 and 2x4 Wood Studs (16" o.c.) and 2" Gap – Triple Glazed Flanged Fiberglass Window Intersection with Wood Blocking and Insulated Perimeter

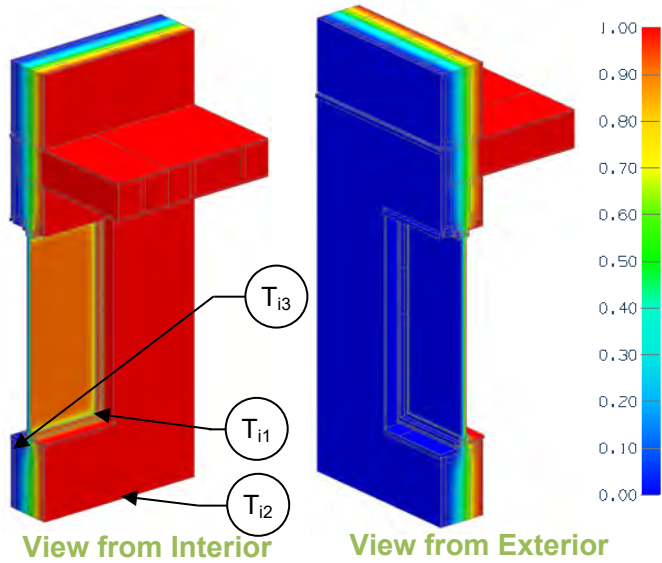

Thermal Performance Indicators

Assembly 1D (Nominal) R-Value	R_{1D}	R-2.5 (0.44 RSI) + insulation
Transmittance / Resistance without Anomaly	U_w, R_w, U_g	"clear wall" U- and R-value: w = wall without intermediate floor, g = glazing
Transmittance / Resistance	$U_{floor}, R_{floor}, U_t, R_t$	U and R-values for: floor = wall + intermediate floor, t = combined wall + floor + window
Surface Temperature Index ¹	T_i	0 = exterior temperature, 1 = interior temperature
Linear Transmittance	Ψ	Incremental increase in transmittance per linear length

¹Assumptions and limitations for surface temperatures identified in ASHRAE 1365-RP

Base Assembly – Glazing

$U_{\text{centre of glass}}$ Btu/ft ² · hr · °F (W/m ² K)	U_g Btu/ft ² · hr · °F (W/m ² K)
0.156 (0.888)	0.180 (1.020)

Nominal (1D) vs. Assembly Performance Indicators

Base Assembly – Wood Stud Clear Wall

Fill Insulation 1D R-Value (RSI)	R_{1D} ft ² ·hr·°F / Btu (m ² K / W)	R_w ft ² ·hr·°F / Btu (m ² K / W)	U_w Btu/ft ² · hr · °F (W/m ² K)
R-38.5 (6.78)	R-41.0 (7.23)	R-38.0 (6.70)	0.026 (0.15)
R-44.0 (7.75)	R-46.5 (8.19)	R-42.4 (7.47)	0.024 (0.13)
R-55.0 (9.69)	R-57.5 (10.13)	R-50.8 (8.94)	0.020 (0.11)
R-66.0 (11.62)	R-68.5 (12.07)	R-58.9 (10.37)	0.017 (0.10)

Intermediate Floor Linear Transmittance

R_{floor} ft ² ·hr·°F / Btu (m ² K / W)	U_{floor} Btu/ft ² · hr · °F (W/m ² K)	Ψ_{floor} Btu/ft ² · hr · °F (W/m ² K)
R-36.4 (6.42)	0.027 (0.16)	0.010 (0.018)
R-40.1 (7.07)	0.025 (0.14)	0.012 (0.020)
R-47.2 (8.31)	0.021 (0.12)	0.013 (0.023)
R-53.7 (9.46)	0.019 (0.11)	0.014 (0.025)

Window Transition Transmittance

Fill Insulation 1D R-Value (RSI)	R_t ft ² ·hr·°F / Btu (m ² K / W)	U_t Btu/ft ² · hr · °F (W/m ² K)	Ψ_{Head} Btu/ft · hr · °F (W/m K)	Ψ_{Sill} Btu/ft · hr · °F (W/m K)	Ψ_{Jamb} Btu/ft · hr · °F (W/m K)	Ψ_{Total} Btu/ft · hr · °F (W/m K)
R-38.5 (6.78)	R-13.9 (2.45)	0.072 (0.41)	0.029 (0.049)	0.044 (0.077)	0.031 (0.054)	0.036 (0.062)
R-44.0 (7.75)	R-14.2 (2.51)	0.070 (0.40)	0.029 (0.050)	0.045 (0.078)	0.032 (0.055)	0.037 (0.064)
R-55.0 (9.69)	R-14.8 (2.60)	0.068 (0.38)	0.030 (0.051)	0.046 (0.080)	0.033 (0.058)	0.038 (0.066)
R-66.0 (11.62)	R-15.2 (2.67)	0.066 (0.37)	0.030 (0.052)	0.047 (0.082)	0.034 (0.059)	0.039 (0.067)

Temperature Indices

	R38.5	R44.0	R55.0	R66.0	
T_{i1}	0.66	0.66	0.66	0.66	Min T on window frame, at bottom corner
T_{i2}	0.07	0.07	0.07	0.07	Max T on interior surface of sheathing at studs
T_{i3}	0.02	0.02	0.02	0.02	Min T on interior surface sheathing below window sill between wood stud



Detail 8.3.15

Double Framed Wall with 2x6 and 2x4 Wood Studs (16" o.c.) and 3" Gap – Triple Glazed Flanged Fiberglass Window Intersection with Wood Blocking and Insulated Perimeter

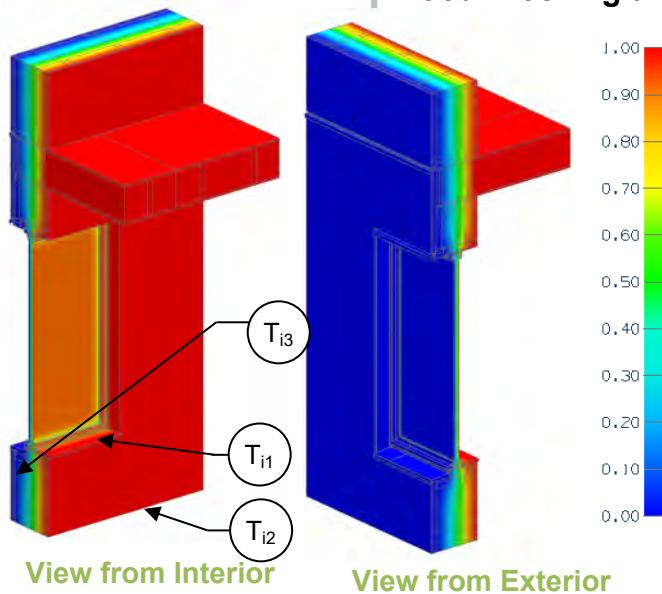

Thermal Performance Indicators

Assembly 1D (Nominal) R-Value	R_{1D}	R-2.5 (0.44 RSI) + insulation
Transmittance / Resistance without Anomaly	U_w, R_w, U_g	"clear wall" U- and R-value: w = wall without intermediate floor g = glazing
Transmittance / Resistance	$U_{floor}, R_{floor}, U_t, R_t$	U and R-values for: floor = wall + intermediate floor t = combined wall + floor + window
Surface Temperature Index ¹	T_i	0 = exterior temperature 1 = interior temperature
Linear Transmittance	Ψ	Incremental increase in transmittance per linear length

¹Assumptions and limitations for surface temperatures identified in ASHRAE 1365-RP

Base Assembly – Glazing

$U_{\text{centre of glass}}$ Btu/ft ² · hr · °F (W/m ² K)	U_g Btu/ft ² · hr · °F (W/m ² K)
0.156 (0.888)	0.180 (1.020)

Nominal (1D) vs. Assembly Performance Indicators

Base Assembly – Wood Stud Clear Wall

Fill Insulation 1D R-Value (RSI)	R_{1D} ft ² ·hr·°F / Btu (m ² K / W)	R_w ft ² ·hr·°F / Btu (m ² K / W)	U_w Btu/ft ² · hr · °F (W/m ² K)
R-42.0 (7.40)	R-44.5 (7.84)	R-41.6 (7.32)	0.024 (0.14)
R-48.0 (8.45)	R-50.5 (8.90)	R-46.4 (8.18)	0.022 (0.12)
R-60.0 (10.57)	R-62.5 (11.01)	R-55.9 (9.84)	0.018 (0.10)
R-72.0 (12.68)	R-74.5 (13.13)	R-65.0 (11.45)	0.015 (0.09)

Intermediate Floor Linear Transmittance

R_{floor} ft ² ·hr·°F / Btu (m ² K / W)	U_{floor} Btu/ft ² · hr · °F (W/m ² K)	Ψ_{floor} Btu/ft ² · hr · °F (W/m ² K)
R-39.9 (7.02)	0.025 (0.14)	0.009 (0.016)
R-44.1 (7.76)	0.023 (0.13)	0.010 (0.017)
R-52.1 (9.17)	0.019 (0.11)	0.011 (0.020)
R-59.6 (10.49)	0.017 (0.10)	0.012 (0.021)

Window Transition Transmittance

Fill Insulation 1D R-Value (RSI)	R_t ft ² ·hr·°F / Btu (m ² K / W)	U_t Btu/ft ² · hr · °F (W/m ² K)	Ψ_{Head} Btu/ft · hr · °F (W/m K)	Ψ_{Sill} Btu/ft · hr · °F (W/m K)	Ψ_{Jamb} Btu/ft · hr · °F (W/m K)	Ψ_{Total} Btu/ft · hr · °F (W/m K)
R-42.0 (7.40)	R-14.3 (2.51)	0.070 (0.40)	0.029 (0.050)	0.044 (0.077)	0.031 (0.054)	0.036 (0.062)
R-48.0 (8.45)	R-14.6 (2.57)	0.069 (0.39)	0.029 (0.051)	0.045 (0.078)	0.032 (0.055)	0.037 (0.063)
R-60.0 (10.57)	R-15.1 (2.66)	0.066 (0.38)	0.030 (0.052)	0.046 (0.080)	0.033 (0.057)	0.038 (0.065)
R-72.0 (12.68)	R-15.5 (2.73)	0.064 (0.37)	0.030 (0.052)	0.047 (0.081)	0.034 (0.058)	0.038 (0.066)

Temperature Indices

	R42.0	R48.0	R60.0	R72.0	
T_{i1}	0.66	0.66	0.66	0.66	Min T on window frame, at bottom corner
T_{i2}	0.07	0.06	0.06	0.06	Max T on interior surface of sheathing at studs
T_{i3}	0.02	0.02	0.01	0.01	Min T on interior surface sheathing below window sill between wood stud



Detail 8.3.16

Double Framed Wall with 2x6 and 2x4 Wood Studs (16" o.c.) and 4" Gap – Triple Glazed Flanged Fiberglass Window Intersection with Wood Blocking and Insulated Perimeter

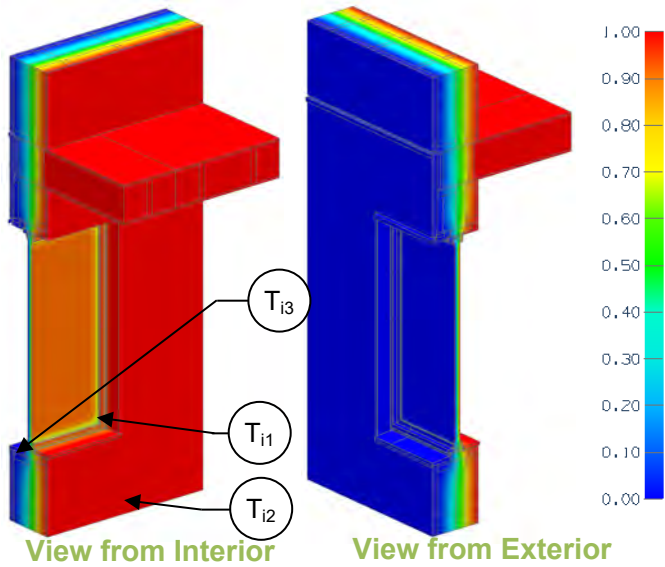

Thermal Performance Indicators

Assembly 1D (Nominal) R-Value	R_{1D}	R-2.5 (0.44 RSI) + insulation
Transmittance / Resistance without Anomaly	U_w, R_w, U_g	"clear wall" U- and R-value: w = wall without intermediate floor g = glazing
Transmittance / Resistance	$U_{floor}, R_{floor}, U_t, R_t$	U and R-values for: floor = wall + intermediate floor t = combined wall + floor + window
Surface Temperature Index ¹	T_i	0 = exterior temperature 1 = interior temperature
Linear Transmittance	Ψ	Incremental increase in transmittance per linear length

¹Assumptions and limitations for surface temperatures identified in ASHRAE 1365-RP

Base Assembly – Glazing

$U_{\text{centre of glass}}$ Btu/ft ² · hr · °F (W/m ² K)	U_g Btu/ft ² · hr · °F (W/m ² K)
0.156 (0.888)	0.180 (1.020)

Nominal (1D) vs. Assembly Performance Indicators

Base Assembly – Wood Stud Clear Wall

Fill Insulation 1D R-Value (RSI)	R_{1D} ft ² ·hr·°F / Btu (m ² K / W)	R_w ft ² ·hr·°F / Btu (m ² K / W)	U_w Btu/ft ² · hr · °F (W/m ² K)
R-45.5 (8.01)	R-48.0 (8.46)	R-45.1 (7.94)	0.022 (0.13)
R-52.0 (9.16)	R-54.5 (9.60)	R-50.5 (8.89)	0.020 (0.11)
R-65.0 (11.45)	R-67.5 (11.89)	R-60.9 (10.73)	0.016 (0.09)
R-78.0 (13.74)	R-80.5 (14.18)	R-71.1 (12.52)	0.014 (0.08)

Intermediate Floor Linear Transmittance

R_{floor} ft ² ·hr·°F / Btu (m ² K / W)	U_{floor} Btu/ft ² · hr · °F (W/m ² K)	Ψ_{floor} Btu/ft ² · hr · °F (W/m ² K)
R-43.3 (7.62)	0.023 (0.13)	0.008 (0.014)
R-48.0 (8.45)	0.021 (0.12)	0.009 (0.016)
R-56.9 (10.03)	0.018 (0.10)	0.010 (0.018)
R-65.3 (11.51)	0.015 (0.09)	0.011 (0.019)

Window Transition Transmittance

Fill Insulation 1D R-Value (RSI)	R_t ft ² ·hr·°F / Btu (m ² K / W)	U_t Btu/ft ² · hr · °F (W/m ² K)	Ψ_{Head} Btu/ft · hr · °F (W/m K)	Ψ_{Sill} Btu/ft · hr · °F (W/m K)	Ψ_{Jamb} Btu/ft · hr · °F (W/m K)	Ψ_{Total} Btu/ft · hr · °F (W/m K)
R-45.5 (8.01)	R-14.6 (2.56)	0.069 (0.39)	0.029 (0.050)	0.045 (0.078)	0.031 (0.054)	0.036 (0.062)
R-52.0 (9.16)	R-14.9 (2.62)	0.067 (0.38)	0.030 (0.051)	0.046 (0.079)	0.032 (0.055)	0.037 (0.063)
R-65.0 (11.45)	R-15.4 (2.72)	0.065 (0.37)	0.030 (0.053)	0.047 (0.081)	0.033 (0.057)	0.038 (0.065)
R-78.0 (13.74)	R-15.8 (2.78)	0.063 (0.36)	0.031 (0.053)	0.047 (0.082)	0.033 (0.058)	0.038 (0.066)

Temperature Indices

	R45.5	R52.0	R65.0	R78.0	
T_{11}	0.66	0.66	0.66	0.66	Min T on window frame, at bottom corner
T_{12}	0.06	0.06	0.06	0.05	Max T on interior surface of sheathing at studs
T_{13}	0.01	0.01	0.01	0.01	Min T on interior surface sheathing below window sill between wood stud



Detail 8.3.17

Double Framed Wall with 2x6 and 2x4 Wood Studs (16" o.c.) Wall and 2" Gap – Triple Glazed Rebated Fiberglass Window Intersection and Un-Insulated Perimeter

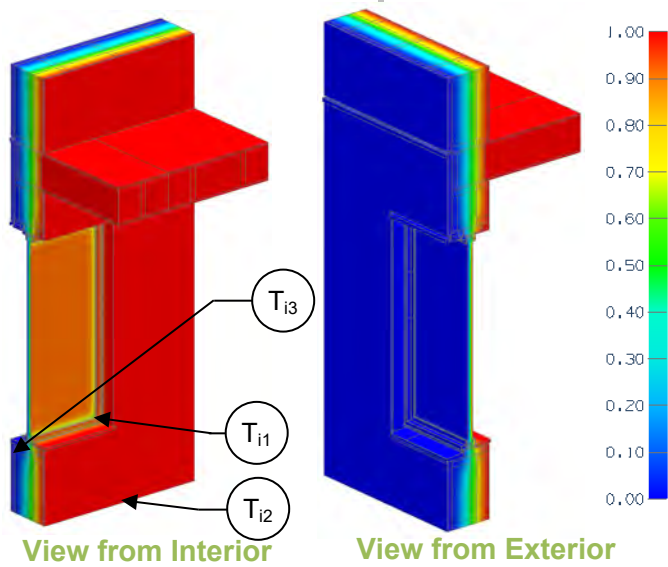

Thermal Performance Indicators

Assembly 1D (Nominal) R-Value	R_{1D}	R-2.5 (0.44 RSI) + cavity insulation
Transmittance / Resistance without Anomaly	U_w, R_w, U_g	"clear wall" U- and R-value: w = wall without intermediate floor g = glazing
Transmittance / Resistance	$U_{floor}, R_{floor}, U_t, R_t$	U and R-values for: floor = wall + intermediate floor t = combined wall + floor + window
Surface Temperature Index ¹	T_i	0 = exterior temperature 1 = interior temperature
Linear Transmittance	ψ	Incremental increase in transmittance per linear length

Base Assembly – Glazing

$U_{\text{centre of glass}}$ Btu/ft ² · hr · °F (W/m ² K)	U_g Btu/ft ² · hr · °F (W/m ² K)
0.156 (0.89)	0.180 (1.02)

¹Assumptions and limitations for surface temperatures identified in ASHRAE 1365-RP

Nominal (1D) vs. Assembly Performance Indicators

Base Assembly – Wood Stud Clear Wall

Fill Insulation 1D R-Value (RSI)	R_{1D} ft ² ·hr·°F / Btu (m ² K / W)	R_w ft ² ·hr·°F / Btu (m ² K / W)	U_w Btu/ft ² · hr · °F (W/m ² K)
R-38.5 (6.78)	R-41.0 (7.23)	R-38.0 (6.70)	0.026 (0.15)
R-44.0 (7.75)	R-46.5 (8.19)	R-42.4 (7.47)	0.024 (0.13)
R-55.0 (9.69)	R-57.5 (10.13)	R-50.8 (8.94)	0.020 (0.11)
R-66.0 (11.62)	R-68.5 (12.07)	R-58.9 (10.37)	0.017 (0.10)

Intermediate Floor Linear Transmittance

R_{floor} ft ² ·hr·°F / Btu (m ² K / W)	U_{floor} Btu/ft ² · hr · °F (W/m ² K)	ψ_{floor} Btu/ft ² · hr · °F (W/m ² K)
R-36.4 (6.42)	0.027 (0.16)	0.010 (0.018)
R-40.1 (7.07)	0.025 (0.14)	0.012 (0.020)
R-47.2 (8.31)	0.021 (0.12)	0.013 (0.023)
R-53.7 (9.46)	0.019 (0.11)	0.014 (0.025)

Window Transition Transmittance

Fill Insulation 1D R-Value (RSI)	R_t ft ² ·hr·°F / Btu (m ² K / W)	U_t Btu/ft ² · hr · °F (W/m ² K)	ψ_{Head} Btu/ft · hr · °F (W/m K)	ψ_{Sill} Btu/ft · hr · °F (W/m K)	ψ_{Jamb} Btu/ft · hr · °F (W/m K)	ψ_{Total} Btu/ft · hr · °F (W/m K)
R-38.5 (6.78)	R-13.4 (2.36)	0.075 (0.42)	0.043 (0.075)	0.045 (0.078)	0.052 (0.091)	0.048 (0.083)
R-44.0 (7.75)	R-13.7 (2.42)	0.073 (0.41)	0.043 (0.075)	0.046 (0.079)	0.053 (0.091)	0.048 (0.083)
R-55.0 (9.69)	R-14.3 (2.51)	0.070 (0.40)	0.043 (0.075)	0.046 (0.079)	0.054 (0.093)	0.048 (0.084)
R-66.0 (11.62)	R-14.7 (2.58)	0.068 (0.39)	0.044 (0.075)	0.046 (0.080)	0.054 (0.094)	0.049 (0.084)

Temperature Indices

	R38.5	R44.0	R55.0	R66.0	
T_{11}	0.65	0.65	0.65	0.65	Min T on window frame, at bottom corner
T_{12}	0.08	0.07	0.07	0.07	Max T on interior surface of exterior sheathing at studs
T_{13}	0.01	0.01	0.01	0.01	Min T on interior surface of exterior sheathing below window sill



Detail 8.3.18

Double Framed Wall with 2x6 and 2x4 Wood Studs (16" o.c.) Wall and 3" Gap – Triple Glazed Rebated Fiberglass Window Intersection and Un-insulated Perimeter

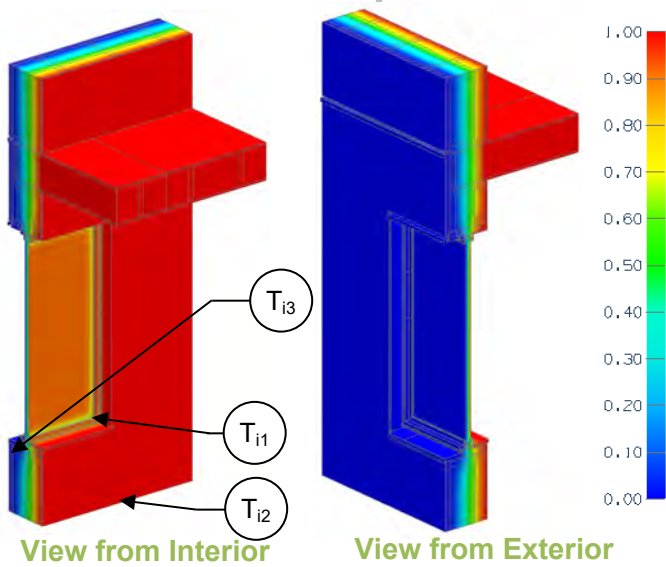

Thermal Performance Indicators

Assembly 1D (Nominal) R-Value	R_{1D}	R-2.5 (0.44 RSI) + cavity insulation
Transmittance / Resistance without Anomaly	U_w, R_w, U_g	"clear wall" U- and R-value: w = wall without intermediate floor g = glazing
Transmittance / Resistance	$U_{floor}, R_{floor}, U_t, R_t$	U and R-values for: floor = wall + intermediate floor t = combined wall + floor + window
Surface Temperature Index ¹	T_i	0 = exterior temperature 1 = interior temperature
Linear Transmittance	ψ	Incremental increase in transmittance per linear length

Base Assembly – Glazing

$U_{\text{centre of glass}}$ Btu/ft ² · hr · °F (W/m ² K)	U_g Btu/ft ² · hr · °F (W/m ² K)
0.156 (0.89)	0.180 (1.02)

¹Assumptions and limitations for surface temperatures identified in ASHRAE 1365-RP

Nominal (1D) vs. Assembly Performance Indicators

Base Assembly – Wood Stud Clear Wall

Fill Insulation 1D R-Value (RSI)	R_{1D} ft ² ·hr·°F / Btu (m ² K / W)	R_w ft ² ·hr·°F / Btu (m ² K / W)	U_w Btu/ft ² · hr · °F (W/m ² K)
R-42.0 (7.40)	R-44.5 (7.84)	R-41.6 (7.32)	0.024 (0.14)
R-48.0 (8.45)	R-50.5 (8.90)	R-46.4 (8.18)	0.022 (0.12)
R-60.0 (10.57)	R-62.5 (11.01)	R-55.9 (9.84)	0.018 (0.10)
R-72.0 (12.68)	R-74.5 (13.13)	R-65.0 (11.45)	0.015 (0.09)

Intermediate Floor Linear Transmittance

R_{floor} ft ² ·hr·°F / Btu (m ² K / W)	U_{floor} Btu/ft ² · hr · °F (W/m ² K)	ψ_{floor} Btu/ft ² · hr · °F (W/m ² K)
R-39.9 (7.02)	0.025 (0.14)	0.009 (0.016)
R-44.1 (7.76)	0.023 (0.13)	0.010 (0.017)
R-52.1 (9.17)	0.019 (0.11)	0.011 (0.020)
R-59.6 (10.49)	0.017 (0.10)	0.012 (0.021)

Window Transition Transmittance

Fill Insulation 1D R-Value (RSI)	R_t ft ² ·hr·°F / Btu (m ² K / W)	U_t Btu/ft ² · hr · °F (W/m ² K)	ψ_{Head} Btu/ft · hr · °F (W/m K)	ψ_{Sill} Btu/ft · hr · °F (W/m K)	ψ_{Jamb} Btu/ft · hr · °F (W/m K)	ψ_{Total} Btu/ft · hr · °F (W/m K)
R-42.0 (7.40)	R-13.7 (2.41)	0.073 (0.41)	0.046 (0.080)	0.046 (0.079)	0.054 (0.093)	0.049 (0.085)
R-48.0 (8.45)	R-14.0 (2.47)	0.071 (0.40)	0.047 (0.081)	0.046 (0.080)	0.054 (0.094)	0.049 (0.085)
R-60.0 (10.57)	R-14.5 (2.56)	0.069 (0.39)	0.047 (0.081)	0.046 (0.080)	0.055 (0.094)	0.050 (0.086)
R-72.0 (12.68)	R-14.9 (2.63)	0.067 (0.38)	0.047 (0.081)	0.046 (0.080)	0.055 (0.095)	0.050 (0.086)

Temperature Indices

	R42.0	R48.0	R60.0	R72.0	
T_{i1}	0.65	0.65	0.65	0.65	Min T on window frame, at bottom corner
T_{i2}	0.07	0.07	0.06	0.06	Max T on interior surface of exterior sheathing at studs
T_{i3}	0.01	0.01	0.01	0.01	Min T on interior surface of exterior sheathing below window sill



Detail 8.3.19

Double Framed Wall with 2x6 and 2x4 Wood Studs (16" o.c.) Wall and 4" Gap – Triple Glazed Rebated Fiberglass Window Intersection and Un-insulated Perimeter

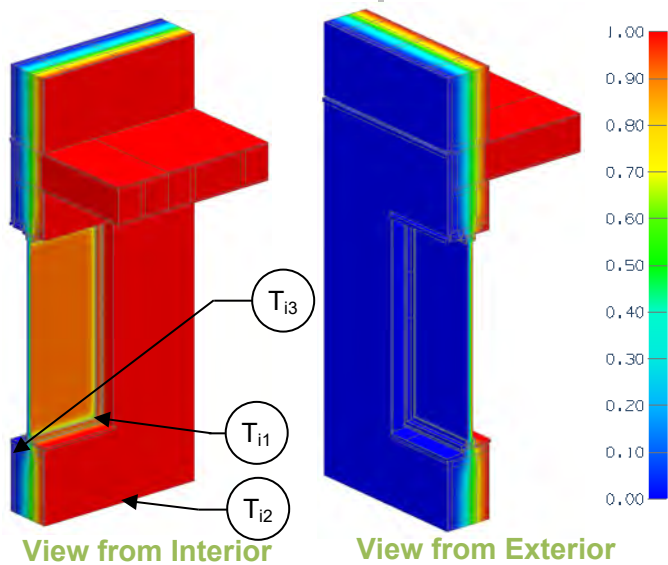

Thermal Performance Indicators

Assembly 1D (Nominal) R-Value	R_{1D}	R-2.5 (0.44 RSI) + cavity insulation
Transmittance / Resistance without Anomaly	U_w, R_w, U_g	"clear wall" U- and R-value: w = wall without intermediate floor g = glazing
Transmittance / Resistance	$U_{floor}, R_{floor}, U_t, R_t$	U and R-values for: floor = wall + intermediate floor t = combined wall + floor + window
Surface Temperature Index ¹	T_i	0 = exterior temperature 1 = interior temperature
Linear Transmittance	ψ	Incremental increase in transmittance per linear length

Base Assembly – Glazing

$U_{\text{centre of glass}}$ Btu/ft ² · hr · °F (W/m ² K)	U_g Btu/ft ² · hr · °F (W/m ² K)
0.156 (0.89)	0.180 (1.02)

¹Assumptions and limitations for surface temperatures identified in ASHRAE 1365-RP

Nominal (1D) vs. Assembly Performance Indicators

Base Assembly – Wood Stud Clear Wall

Fill Insulation 1D R-Value (RSI)	R_{1D} ft ² ·hr·°F / Btu (m ² K / W)	R_w ft ² ·hr·°F / Btu (m ² K / W)	U_w Btu/ft ² · hr · °F (W/m ² K)
R-45.5 (8.01)	R-48.0 (8.46)	R-45.1 (7.94)	0.022 (0.13)
R-52.0 (9.16)	R-54.5 (9.60)	R-50.5 (8.89)	0.020 (0.11)
R-65.0 (11.45)	R-67.5 (11.89)	R-60.9 (10.73)	0.016 (0.09)
R-78.0 (13.74)	R-80.5 (14.18)	R-71.1 (12.52)	0.014 (0.08)

Intermediate Floor Linear Transmittance

R_{floor} ft ² ·hr·°F / Btu (m ² K / W)	U_{floor} Btu/ft ² · hr · °F (W/m ² K)	ψ_{floor} Btu/ft ² · hr · °F (W/m ² K)
R-43.3 (7.62)	0.023 (0.13)	0.008 (0.014)
R-48.0 (8.45)	0.021 (0.12)	0.009 (0.016)
R-56.9 (10.03)	0.018 (0.10)	0.010 (0.018)
R-65.3 (11.51)	0.015 (0.09)	0.011 (0.019)

Window Transition Transmittance

Fill Insulation 1D R-Value (RSI)	R_t ft ² ·hr·°F / Btu (m ² K / W)	U_t Btu/ft ² · hr · °F (W/m ² K)	ψ_{Head} Btu/ft · hr · °F (W/m K)	ψ_{Sill} Btu/ft · hr · °F (W/m K)	ψ_{Jamb} Btu/ft · hr · °F (W/m K)	ψ_{Total} Btu/ft · hr · °F (W/m K)
R-45.5 (8.01)	R-13.9 (2.45)	0.072 (0.41)	0.049 (0.085)	0.047 (0.081)	0.055 (0.095)	0.050 (0.087)
R-52.0 (9.16)	R-14.2 (2.51)	0.070 (0.40)	0.049 (0.086)	0.047 (0.081)	0.055 (0.096)	0.051 (0.088)
R-65.0 (11.45)	R-14.8 (2.60)	0.068 (0.38)	0.050 (0.086)	0.047 (0.081)	0.056 (0.096)	0.051 (0.088)
R-78.0 (13.74)	R-15.1 (2.67)	0.066 (0.38)	0.050 (0.086)	0.047 (0.081)	0.056 (0.097)	0.051 (0.088)

Temperature Indices

	R45.5	R52.0	R65.0	R78.0	
T_{i1}	0.65	0.65	0.65	0.65	Min T on window frame, at bottom corner
T_{i2}	0.06	0.06	0.06	0.05	Max T on interior surface of exterior sheathing at studs
T_{i3}	0.01	0.01	0.01	0.01	Min T on interior surface of exterior sheathing below window sill



Detail 8.3.20

Double Framed Wall with 2x6 and 2x4 Wood Studs (16" o.c.) Wall and 2" Gap – Triple Glazed Rebated Fiberglass Window Intersection with Insulation at Window Perimeter

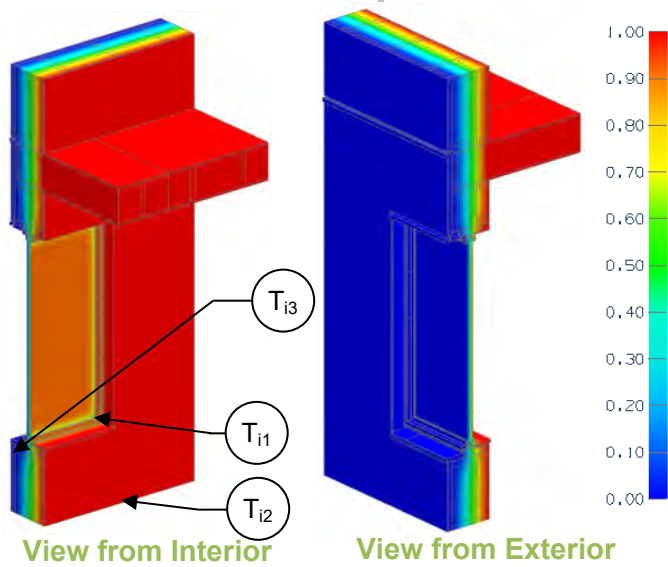

Thermal Performance Indicators

Assembly 1D (Nominal) R-Value	R_{1D}	R-2.5 (0.44 RSI) + cavity insulation
Transmittance / Resistance without Anomaly	U_w, R_w, U_g	"clear wall" U- and R-value: w = wall without intermediate floor g = glazing
Transmittance / Resistance	$U_{floor}, R_{floor}, U_t, R_t$	U and R-values for: floor = wall + intermediate floor t = combined wall + floor + window
Surface Temperature Index ¹	T_i	0 = exterior temperature 1 = interior temperature
Linear Transmittance	ψ	Incremental increase in transmittance per linear length

Base Assembly – Glazing

$U_{\text{centre of glass}}$ Btu/ft ² · hr · °F (W/m ² K)	U_g Btu/ft ² · hr · °F (W/m ² K)
0.156 (0.89)	0.180 (1.02)

¹Assumptions and limitations for surface temperatures identified in ASHRAE 1365-RP

Nominal (1D) vs. Assembly Performance Indicators

Base Assembly – Wood Stud Clear Wall

Fill Insulation 1D R-Value (RSI)	R_{1D} ft ² ·hr·°F / Btu (m ² K / W)	R_w ft ² ·hr·°F / Btu (m ² K / W)	U_w Btu/ft ² · hr · °F (W/m ² K)
R-38.5 (6.78)	R-41.0 (7.23)	R-38.0 (6.70)	0.026 (0.15)
R-44.0 (7.75)	R-46.5 (8.19)	R-42.4 (7.47)	0.024 (0.13)
R-55.0 (9.69)	R-57.5 (10.13)	R-50.8 (8.94)	0.020 (0.11)
R-66.0 (11.62)	R-68.5 (12.07)	R-58.9 (10.37)	0.017 (0.10)

Intermediate Floor Linear Transmittance

R_{floor} ft ² ·hr·°F / Btu (m ² K / W)	U_{floor} Btu/ft ² · hr · °F (W/m ² K)	ψ_{floor} Btu/ft ² · hr · °F (W/m ² K)
R-36.4 (6.42)	0.027 (0.16)	0.010 (0.018)
R-40.1 (7.07)	0.025 (0.14)	0.012 (0.020)
R-47.2 (8.31)	0.021 (0.12)	0.013 (0.023)
R-53.7 (9.46)	0.019 (0.11)	0.014 (0.025)

Window Transition Transmittance

Fill Insulation 1D R-Value (RSI)	R_t ft ² ·hr·°F / Btu (m ² K / W)	U_t Btu/ft ² · hr · °F (W/m ² K)	ψ_{Head} Btu/ft · hr · °F (W/m K)	ψ_{Sill} Btu/ft · hr · °F (W/m K)	ψ_{Jamb} Btu/ft · hr · °F (W/m K)	ψ_{Total} Btu/ft · hr · °F (W/m K)
R-38.5 (6.78)	R-14.4 (2.53)	0.070 (0.40)	0.022 (0.038)	0.026 (0.046)	0.028 (0.048)	0.025 (0.044)
R-44.0 (7.75)	R-14.7 (2.60)	0.068 (0.39)	0.022 (0.037)	0.027 (0.046)	0.028 (0.049)	0.026 (0.044)
R-55.0 (9.69)	R-15.4 (2.70)	0.065 (0.37)	0.021 (0.037)	0.027 (0.047)	0.029 (0.050)	0.026 (0.045)
R-66.0 (11.62)	R-15.8 (2.79)	0.063 (0.36)	0.022 (0.037)	0.027 (0.047)	0.029 (0.050)	0.026 (0.045)

Temperature Indices

	R38.5	R44.0	R55.0	R66.0	
T_{i1}	0.67	0.67	0.67	0.67	Min T on window frame, at bottom corner
T_{i2}	0.08	0.07	0.07	0.07	Max T on interior surface of exterior sheathing at studs
T_{i3}	0.01	0.01	0.01	0.00	Min T on interior surface of exterior sheathing below window sill



Detail 8.3.21

Double Framed Wall with 2x6 and 2x4 Wood Studs (16" o.c.) Wall and 3" Gap – Triple Glazed Rebated Fiberglass Window Intersection with Insulation at Window Perimeter

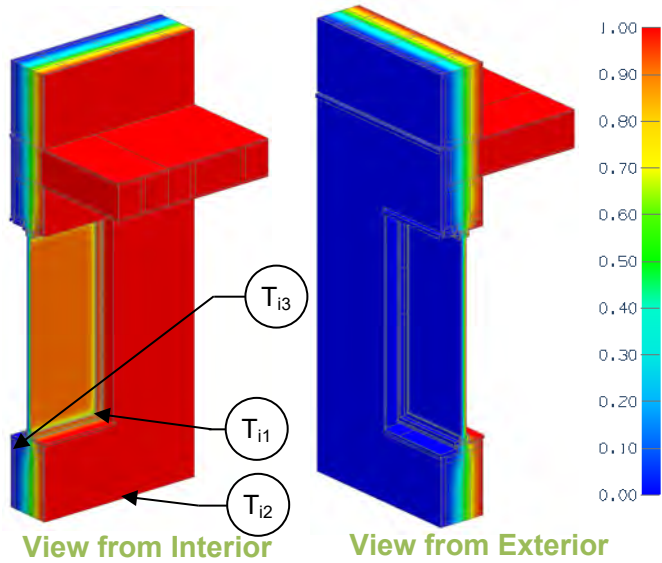

Thermal Performance Indicators

Assembly 1D (Nominal) R-Value	R_{1D}	R-2.5 (0.44 RSI) + cavity insulation
Transmittance / Resistance without Anomaly	U_w, R_w, U_g	"clear wall" U- and R-value: w = wall without intermediate floor g = glazing
Transmittance / Resistance	$U_{floor}, R_{floor}, U_t, R_t$	U and R-values for: floor = wall + intermediate floor t = combined wall + floor + window
Surface Temperature Index ¹	T_i	0 = exterior temperature 1 = interior temperature
Linear Transmittance	Ψ	Incremental increase in transmittance per linear length

¹Assumptions and limitations for surface temperatures identified in ASHRAE 1365-RP

Base Assembly – Glazing

$U_{\text{centre of glass}}$ Btu/ft ² · hr · °F (W/m ² K)	U_g Btu/ft ² · hr · °F (W/m ² K)
0.156 (0.89)	0.180 (1.02)

Nominal (1D) vs. Assembly Performance Indicators

Base Assembly – Wood Stud Clear Wall

Fill Insulation 1D R-Value (RSI)	R_{1D} ft ² ·hr·°F / Btu (m ² K / W)	R_w ft ² ·hr·°F / Btu (m ² K / W)	U_w Btu/ft ² · hr · °F (W/m ² K)
R-42.0 (7.40)	R-44.5 (7.84)	R-41.6 (7.32)	0.024 (0.14)
R-48.0 (8.45)	R-50.5 (8.90)	R-46.4 (8.18)	0.022 (0.12)
R-60.0 (10.57)	R-62.5 (11.01)	R-55.9 (9.84)	0.018 (0.10)
R-72.0 (12.68)	R-74.5 (13.13)	R-65.0 (11.45)	0.015 (0.09)

Intermediate Floor Linear Transmittance

R_{floor} ft ² ·hr·°F / Btu (m ² K / W)	U_{floor} Btu/ft ² · hr · °F (W/m ² K)	Ψ_{floor} Btu/ft ² · hr · °F (W/m ² K)
R-39.9 (7.02)	0.025 (0.14)	0.009 (0.016)
R-44.1 (7.76)	0.023 (0.13)	0.010 (0.017)
R-52.1 (9.17)	0.019 (0.11)	0.011 (0.020)
R-59.6 (10.49)	0.017 (0.10)	0.012 (0.021)

Window Transition Transmittance

Fill Insulation 1D R-Value (RSI)	R_t ft ² ·hr·°F / Btu (m ² K / W)	U_t Btu/ft ² · hr · °F (W/m ² K)	Ψ_{Head} Btu/ft · hr · °F (W/m K)	Ψ_{Sill} Btu/ft · hr · °F (W/m K)	Ψ_{Jamb} Btu/ft · hr · °F (W/m K)	Ψ_{Total} Btu/ft · hr · °F (W/m K)
R-42.0 (7.40)	R-14.7 (2.60)	0.068 (0.39)	0.023 (0.039)	0.026 (0.046)	0.028 (0.048)	0.025 (0.044)
R-48.0 (8.45)	R-15.1 (2.67)	0.066 (0.38)	0.023 (0.040)	0.027 (0.046)	0.028 (0.048)	0.025 (0.044)
R-60.0 (10.57)	R-15.7 (2.77)	0.064 (0.36)	0.023 (0.039)	0.027 (0.046)	0.028 (0.049)	0.026 (0.045)
R-72.0 (12.68)	R-16.2 (2.86)	0.062 (0.35)	0.023 (0.039)	0.027 (0.046)	0.028 (0.049)	0.026 (0.044)

Temperature Indices

	R42.0	R48.0	R60.0	R72.0	
T_{11}	0.67	0.67	0.67	0.67	Min T on window frame, at bottom corner
T_{12}	0.07	0.07	0.06	0.06	Max T on interior surface of exterior sheathing at studs
T_{13}	0.00	0.00	0.00	0.00	Min T on interior surface of exterior sheathing below window sill



Detail 8.3.22

Double Framed Wall with 2x6 and 2x4 Wood Studs (16" o.c.) Wall and 4" Gap – Triple Glazed Rebated Fiberglass Window Intersection with Insulation at Window Perimeter

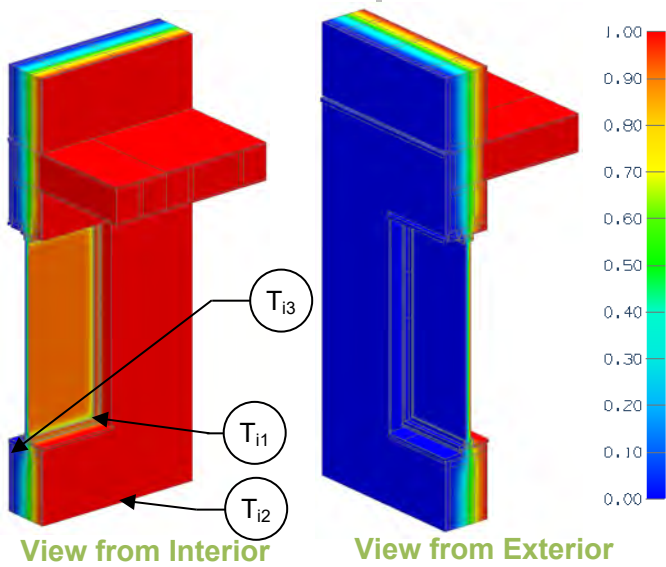

Thermal Performance Indicators

Assembly 1D (Nominal) R-Value	R_{1D}	R-2.5 (0.44 RSI) + cavity insulation
Transmittance / Resistance without Anomaly	U_w, R_w, U_g	"clear wall" U- and R-value: w = wall without intermediate floor g = glazing
Transmittance / Resistance	$U_{floor}, R_{floor}, U_t, R_t$	U and R-values for: floor = wall + intermediate floor t = combined wall + floor + window
Surface Temperature Index ¹	T_i	0 = exterior temperature 1 = interior temperature
Linear Transmittance	ψ	Incremental increase in transmittance per linear length

¹Assumptions and limitations for surface temperatures identified in ASHRAE 1365-RP

Base Assembly – Glazing

$U_{\text{centre of glass}}$ Btu/ft ² · hr · °F (W/m ² K)	U_g Btu/ft ² · hr · °F (W/m ² K)
0.156 (0.89)	0.180 (1.02)

Nominal (1D) vs. Assembly Performance Indicators

Base Assembly – Wood Stud Clear Wall

Fill Insulation 1D R-Value (RSI)	R_{1D} ft ² ·hr·°F / Btu (m ² K / W)	R_w ft ² ·hr·°F / Btu (m ² K / W)	U_w Btu/ft ² · hr · °F (W/m ² K)
R-45.5 (8.01)	R-48.0 (8.46)	R-45.1 (7.94)	0.022 (0.13)
R-52.0 (9.16)	R-54.5 (9.60)	R-50.5 (8.89)	0.020 (0.11)
R-65.0 (11.45)	R-67.5 (11.89)	R-60.9 (10.73)	0.016 (0.09)
R-78.0 (13.74)	R-80.5 (14.18)	R-71.1 (12.52)	0.014 (0.08)

Intermediate Floor Linear Transmittance

R_{floor} ft ² ·hr·°F / Btu (m ² K / W)	U_{floor} Btu/ft ² · hr · °F (W/m ² K)	ψ_{floor} Btu/ft ² · hr · °F (W/m ² K)
R-43.3 (7.62)	0.023 (0.13)	0.008 (0.014)
R-48.0 (8.45)	0.021 (0.12)	0.009 (0.016)
R-56.9 (10.03)	0.018 (0.10)	0.010 (0.018)
R-65.3 (11.51)	0.015 (0.09)	0.011 (0.019)

Window Transition Transmittance

Fill Insulation 1D R-Value (RSI)	R_t ft ² ·hr·°F / Btu (m ² K / W)	U_t Btu/ft ² · hr · °F (W/m ² K)	ψ_{Head} Btu/ft · hr · °F (W/m K)	ψ_{Sill} Btu/ft · hr · °F (W/m K)	ψ_{Jamb} Btu/ft · hr · °F (W/m K)	ψ_{Total} Btu/ft · hr · °F (W/m K)
R-45.5 (8.01)	R-15.1 (2.65)	0.066 (0.38)	0.024 (0.041)	0.027 (0.046)	0.028 (0.048)	0.025 (0.044)
R-52.0 (9.16)	R-15.5 (2.72)	0.065 (0.37)	0.024 (0.041)	0.027 (0.046)	0.028 (0.048)	0.026 (0.044)
R-65.0 (11.45)	R-16.1 (2.83)	0.062 (0.35)	0.024 (0.041)	0.027 (0.046)	0.028 (0.048)	0.025 (0.044)
R-78.0 (13.74)	R-16.5 (2.91)	0.060 (0.34)	0.023 (0.041)	0.027 (0.046)	0.028 (0.048)	0.025 (0.044)

Temperature Indices

	R45.5	R52.0	R65.0	R78.0	
T_{i1}	0.67	0.67	0.67	0.67	Min T on window frame, at bottom corner
T_{i2}	0.06	0.06	0.06	0.05	Max T on interior surface of exterior sheathing at studs
T_{i3}	0.00	0.00	0.00	0.00	Min T on interior surface of exterior sheathing below window sill



Detail 8.3.23

Exterior and Interior Insulated 2x6 Wood Stud (16" o.c.) Wall Assembly with Wood Strapping and Continuous Insulation Supporting Rainscreen Fiber Cement Board – Double Glazed Aluminum Window Intersection Aligned with Exterior Insulation

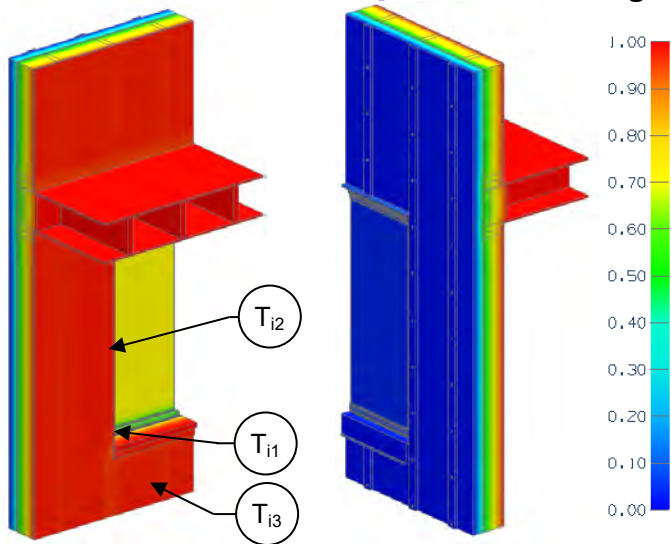

Thermal Performance Indicators

Assembly 1D (Nominal) R-Value	R_{1D}	R-21.5 (3.80 RSI) + exterior insulation
Transmittance / Resistance without Anomaly	U_w, R_w, U_g	“clear wall” U- and R-value: w = wall without intermediate floor g = glazing
Transmittance / Resistance	$U_{floor}, R_{floor}, U_t, R_t$	U and R-values for: floor = wall + intermediate floor t = combined wall + floor + window
Surface Temperature Index ¹	T_i	0 = exterior temperature 1 = interior temperature
Linear Transmittance	Ψ	Incremental increase in transmittance per linear length

View from Interior
Base Assembly – Glazing

View from Exterior

$U_{\text{centre of glass}}$ Btu/ft ² · hr · °F (W/m ² K)	U_g Btu/ft ² · hr · °F (W/m ² K)
0.321 (1.82)	0.400 (2.27)

¹Assumptions and limitations for surface temperatures identified in ASHRAE 1365-RP

Nominal (1D) vs. Assembly Performance Indicators

Base Assembly – Wood Stud Clear Wall

Exterior Insulation 1D R-Value (RSI)	R_{1D} ft ² ·hr·°F / Btu (m ² K / W)	R_w ft ² ·hr·°F / Btu (m ² K / W)	U_w Btu/ft ² · hr · °F (W/m ² K)
R-5.0 (0.88)	R-26.5 (4.68)	R-24.6 (4.32)	0.041 (0.23)
R-15.0 (2.64)	R-36.5 (6.44)	R-33.6 (5.93)	0.030 (0.17)

Intermediate Floor Linear Transmittance

R_{floor} ft ² ·hr·°F / Btu (m ² K / W)	U_{floor} Btu/ft ² · hr · °F (W/m ² K)	Ψ_{floor} Btu/ft ² · hr · °F (W/m ² K)
R-23.4 (4.12)	0.043 (0.24)	0.020 (0.035)
R-32.8 (5.78)	0.031 (0.17)	0.007 (0.012)

Window Transition Transmittance

Exterior Insulation 1D R-Value (RSI)	R_t ft ² ·hr·°F / Btu (m ² K / W)	U_t Btu/ft ² · hr · °F (W/m ² K)	Ψ_{Head} Btu/ft · hr · °F (W/m K)	Ψ_{Sill} Btu/ft · hr · °F (W/m K)	Ψ_{Jamb} Btu/ft · hr · °F (W/m K)	Ψ_{Total} Btu/ft · hr · °F (W/m K)
R-5.0 (0.88)	R-6.8 (1.19)	0.148 (0.84)	0.081 (0.140)	0.049 (0.086)	0.064 (0.110)	0.067 (0.116)
R-15.0 (2.64)	R-7.2 (1.27)	0.138 (0.78)	0.091 (0.157)	0.049 (0.084)	0.060 (0.103)	0.067 (0.117)

Temperature Indices

	R5	R15	
T_{i1}	0.55	0.56	Min T on window frame, at bottom corner
T_{i2}	0.43	0.56	Max T on interior surface of sheathing at studs beside jamb
T_{i3}	0.25	0.46	Min T on interior surface sheathing between wood studs

Detail 8.4.1

Exterior and Interior Insulated 2x6 Wood Stud (16" o.c.) Wall Assembly with Wood Strapping and Continuous Insulation Supporting Rainscreen Fiber Cement Board and R-19 Batt Insulation in Stud Cavity – Vented Low-slope Roof & Parapet Intersection

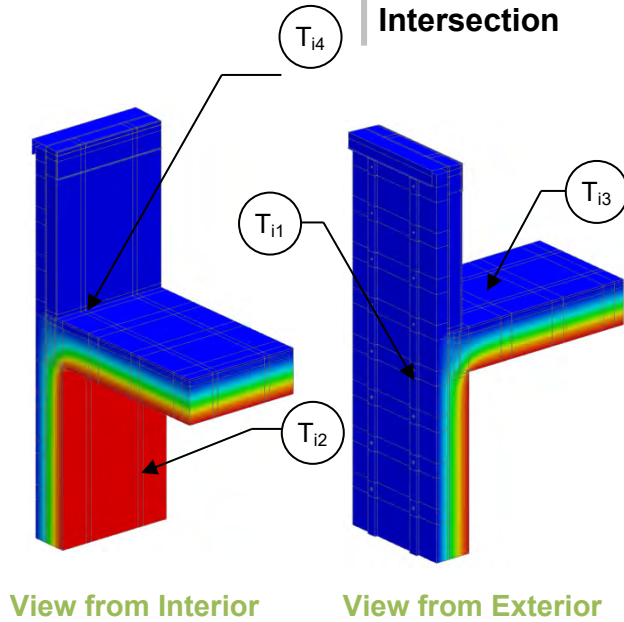

Thermal Performance Indicators

Assembly 1D (Nominal) R-Value	R_{1D}	R-21.6 (3.80 RSI) + exterior insulation
Transmittance / Resistance without Anomaly	U_r, R_r, U_w, R_w	“clear field” U- and R-value r = roof w = wood framed wall without parapet
Transmittance / Resistance	U, R	U and R-values for the overall assembly
Surface Temperature Index ¹	T_i	0 = exterior temperature 1 = interior temperature
Linear Transmittance	ψ	Incremental increase in transmittance per linear length of parapet

¹Assumptions and limitations for surface temperatures identified in ASHRAE 1365-RP

Nominal (1D) vs. Assembly Performance Indicators

Base Assembly – Wall

Wall Exterior Insulation 1D R-Value (RSI)	R_{1D} ft ² ·hr·°F / Btu (m ² K / W)	R_w ft ² ·hr·°F / Btu (m ² K / W)	U_w Btu/ft ² ·hr ·°F (W/m ² K)
R-0 (0)	R-21.6 (3.80)	R-19.7 (3.47)	0.051 (0.29)
R-7.5 (1.32)	R-29.0 (5.12)	R-26.9 (4.74)	0.037 (0.21)
R-15 (2.64)	R-36.6 (6.44)	R-33.7 (5.93)	0.030 (0.17)

Base Assembly – Roof

Roof Insulation 1D R-Value (RSI)	R_r ft ² hr °F / Btu (m ² K / W)	U_r Btu/ft ² ·hr ·°F (W/m ² K)
R-30 (5.28)	R-30.1 (5.3)	0.033 (0.19)

Parapet Linear Transmittance

Wall Exterior Insulation 1D R-Value (RSI)	R ft ² ·hr·°F / Btu (m ² K / W)	U Btu/ft ² ·hr ·°F (W/m ² K)	ψ Btu/ft ·hr ·°F (W/m K)
R-0 (0)	R-22.1 (3.89)	0.045 (0.26)	0.031 (0.054)
R-7.5 (1.32)	R-25.9 (4.56)	0.039 (0.22)	0.032 (0.056)
R-15 (2.64)	R-29.3 (5.15)	0.034 (0.19)	0.026 (0.045)

Temperature Indices

	R0	R7.5	R15	
T_{i1}	-	0.26	0.33	Min T on sheathing, at studs and rim joist intersection
T_{i2}	-	0.35	0.50	Max T on sheathing, at studs between fasteners
T_{i3}	-	0.04	0.04	Min T on roof sheathing, between roof strapping
T_{i4}	0.02	-	-	Min T on roof sheathing, at top of rim joist intersection

Detail 8.4.2

Exterior and Interior Insulated 2x6 Wood Stud (16" o.c.) Wall Assembly with Wood Strapping and Continuous Insulation Supporting Fiber Cement Board and R-19 Batt Insulation in Stud Cavity – Sloped Wood Framed Roof & Wall Intersection with Insulation at Ceiling

Thermal Performance Indicators

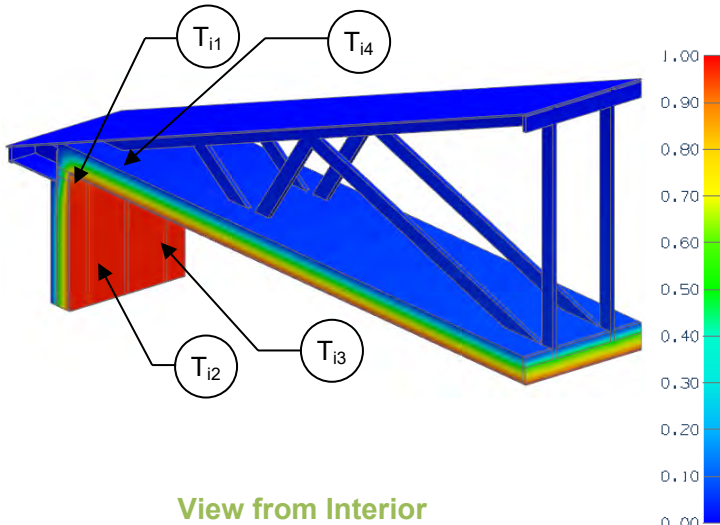

Assembly 1D (Nominal) R-Value	R_{1D}	R-21.6 (3.80 RSI) + exterior insulation
Transmittance / Resistance without Anomaly	U_r, R_r, U_w, R_w	"clear field" U- and R-value r = roof w = wood framed wall without soffit line
Transmittance / Resistance	U, R	U and R-values for the overall assembly
Surface Temperature Index ¹	T_i	0 = exterior temperature 1 = interior temperature
Linear Transmittance	ψ	Incremental increase in transmittance per linear length of soffit line

¹Assumptions and limitations for surface temperatures identified in ASHRAE 1365-RP

Nominal (1D) vs. Assembly Performance Indicators

Base Assembly – Wall

Wall Exterior Insulation 1D R-Value (RSI)	R_{1D} ft ² ·hr·°F / Btu (m ² K / W)	R_w ft ² ·hr·°F / Btu (m ² K / W)	U_w Btu/ft ² ·hr ·°F (W/m ² K)
R-0 (0)	R-22.2 (3.91)	R-19.7 (3.47)	0.051 (0.29)
R-7.5 (1.32)	R-29.2 (5.14)	R-26.9 (4.74)	0.037 (0.21)
R-15 (2.64)	R-36.7 (6.46)	R-33.6 (5.93)	0.030 (0.17)

Base Assembly – Roof

Roof Insulation 1D R-Value (RSI)	R_r ft ² hr °F / Btu (m ² K / W)	U_r Btu/ft ² ·hr ·°F (W/m ² K)
R-30 (5.28)	R-31.5 (5.55)	0.032 (0.18)

Soffit Line Linear Transmittance

Wall Exterior Insulation 1D R-Value (RSI)	R ft ² ·hr·°F / Btu (m ² K / W)	U Btu/ft ² ·hr ·°F (W/m ² K)	ψ Btu/ft ·hr·°F (W/m K)
R-0 (0.00)	R-27.4 (4.83)	0.036 (0.21)	0.035 (0.060)
R-7.5 (1.32)	R-29.0 (5.11)	0.034 (0.20)	0.042 (0.073)
R-15 (2.64)	R-29.9 (5.27)	0.033 (0.19)	0.047 (0.081)

Temperature Indices

	R0	R7.5	R15	
T_{i1}	-	0.11	0.14	Min T on sheathing, between studs at top plate
T_{i2}	-	0.33	0.50	Max T on sheathing, along studs between fasteners
T_{i3}	0.07	-	-	Min T on sheathing, between studs
T_{i4}	0.12	-	-	Max T on sheathing, at top plate and truss intersection

Detail 8.4.3

Exterior and Interior Insulated 2x6 Wood Stud (16" o.c.) Wall Assembly with Wood Strapping and Continuous Insulation Supporting Rainscreen Fiber Cement Board and R-19 Batt Insulation in Stud Cavity – Sloped Wood Framed Roof & Wall Intersection with Insulation at Roof Sheathing

Thermal Performance Indicators

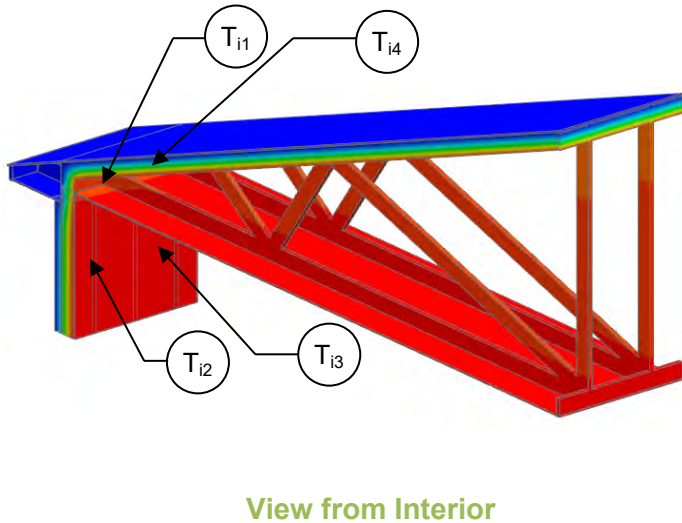

Assembly 1D (Nominal) R-Value	R_{1D}	R-21.6 (3.80 RSI) + exterior insulation
Transmittance / Resistance without Anomaly	U_r, R_r, U_w, R_w	“clear field” U- and R-value r = roof w = wood framed wall without soffit line
Transmittance / Resistance	U, R	U and R-values for the overall assembly
Surface Temperature Index ¹	T_i	0 = exterior temperature 1 = interior temperature
Linear Transmittance	ψ	Incremental increase in transmittance per linear length of soffit line

¹Assumptions and limitations for surface temperatures identified in ASHRAE 1365-RP

Nominal (1D) vs. Assembly Performance Indicators

Base Assembly – Wall

Wall Exterior Insulation 1D R-Value (RSI)	R_{1D} ft ² ·hr·°F / Btu (m ² K / W)	R_w ft ² ·hr·°F / Btu (m ² K / W)	U_w Btu/ft ² ·hr ·°F (W/m ² K)
R-0 (0)	R-22.2 (3.91)	R-19.7 (3.47)	0.051 (0.29)
R-7.5 (1.32)	R-29.2 (5.14)	R-26.9 (4.74)	0.037 (0.21)
R-15 (2.64)	R-36.7 (6.46)	R-33.6 (5.93)	0.030 (0.17)

Base Assembly – Roof

Roof Insulation 1D R-Value (RSI)	R_r ft ² hr °F / Btu (m ² K / W)	U_r Btu/ft ² ·hr ·°F (W/m ² K)
R-30 (5.28)	R-27.0 (4.76)	0.037 (0.21)

Soffit Line Linear Transmittance

Wall Exterior Insulation 1D R-Value (RSI)	R ft ² ·hr·°F / Btu (m ² K / W)	U Btu/ft ² ·hr ·°F (W/m ² K)	ψ Btu/ft ·hr·°F (W/m K)
R-0 (0.00)	R-24.2 (4.27)	0.041 (0.23)	0.045 (0.079)
R-7.5 (1.32)	R-25.5 (4.48)	0.039 (0.22)	0.053 (0.092)
R-15 (2.64)	R-26.1 (4.60)	0.038 (0.22)	0.059 (0.102)

Temperature Indices

	R0	R7.5	R15	
T_{11}	-	0.12	0.14	Min T on sheathing, between studs at top plate
T_{12}	-	0.33	0.47	Max T on sheathing, along studs between fasteners
T_{13}	0.07	-	-	Min T on sheathing, between studs
T_{14}	0.21	-	-	Max T on sheathing, at top plate and truss intersection

Detail 8.4.4

Ventilated Wood Frame Low Slope Roof – Masonry Firewall Intersection

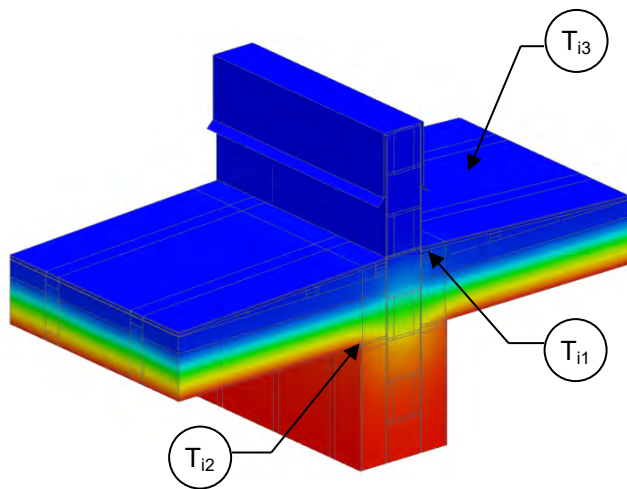

Thermal Performance Indicators

Assembly 1D (Nominal) R-Value	R_{1D}	R-3.5 (0.62 RSI) + exterior insulation
Transmittance / Resistance without Anomaly	U_o, R_o	“clear field” U- and R-value, without firewall
Transmittance / Resistance	U, R	U and R-values for the overall assembly
Surface Temperature Index ¹	T_i	0 = exterior temperature 1 = interior temperature
Linear Transmittance	ψ	Incremental increase in transmittance per linear length of fire wall

¹Assumptions and limitations for surface temperatures identified in ASHRAE 1365-RP

Nominal (1D) vs. Assembly Performance Indicators

Roof Insulation 1D R-Value (RSI)	R_{1D} ft ² ·hr·°F / Btu (m ² K / W)	R_o ft ² ·hr·°F / Btu (m ² K / W)	U_o Btu/ft ² ·hr ·°F (W/m ² K)	R ft ² ·hr·°F / Btu (m ² K / W)	U Btu/ft ² ·hr ·°F (W/m ² K)	ψ Btu/ft ·hr·°F (W/m K)
R-30 (5.28)	R-33.1 (5.83)	R-31.8 (5.59)	0.031 (0.18)	R-26.2 (4.63)	0.038 (0.22)	0.057 (0.099)

Temperature Indices

T_{i1}	0.05	Min T on concrete block, at roof sheathing intersection
T_{i2}	0.76	Max T on concrete block, at roof joist intersection
T_{i3}	0.04	Min T on roof sheathing, between joists

Detail 8.4.5

Exterior Insulated Cross Laminated Timber (CLT) Wall Assembly with Continuous Rigid Insulation Supporting Fiber Cement Board – Low-Slope Roof & Parapet Intersection

Thermal Performance Indicators

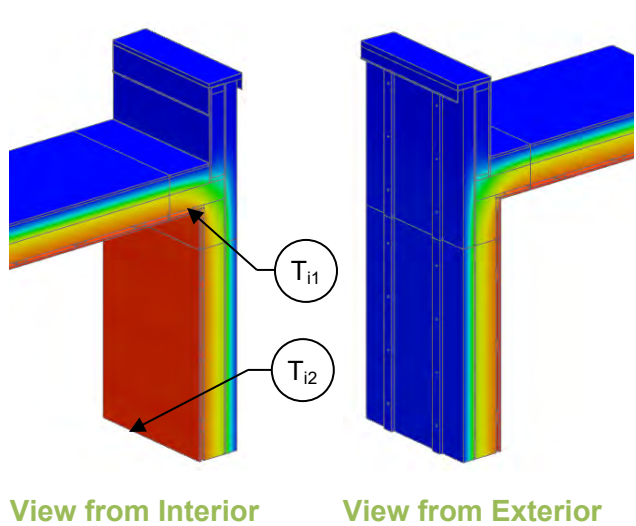

Assembly 1D (Nominal) R-Value	R_{1D}	R-9.9 (1.74 RSI) + exterior insulation
Transmittance / Resistance without Anomaly	U_r, R_r, U_w, R_w	“clear field” U- and R-value r = roof w = CLT wall without parapet
Transmittance / Resistance	U, R	U and R-values for the overall assembly
Surface Temperature Index ¹	T_i	0 = exterior temperature 1 = interior temperature
Linear Transmittance	ψ	Incremental increase in transmittance per linear length of parapet

¹Assumptions and limitations for surface temperatures identified in ASHRAE 1365-RP

Nominal (1D) vs. Assembly Performance Indicators

Base Assembly – Wall

Wall Exterior Insulation 1D R-Value (RSI)	R_{1D} ft ² ·hr·°F / Btu (m ² K / W)	R_w ft ² ·hr·°F / Btu (m ² K / W)	U_w Btu/ft ² ·hr ·°F (W/m ² K)
R-15.0 (2.64)	R-24.9 (4.38)	R-24.7 (4.35)	0.040 (0.23)
R-20.0 (3.52)	R-29.9 (5.26)	R-29.4 (5.17)	0.034 (0.19)
R-25.0 (4.40)	R-34.9 (6.14)	R-33.9 (5.98)	0.029 (0.17)

Base Assembly – Roof

Roof Insulation 1D R-Value (RSI)	R_r ft ² hr ·°F / Btu (m ² K / W)	U_r Btu/ft ² ·hr ·°F (W/m ² K)
R-20.0 (3.52)	R-28.1 (4.96)	0.036 (0.20)
R-30.0 (5.28)	R-38.1 (6.72)	0.026 (0.15)
R-40.0 (7.04)	R-48.1 (8.48)	0.021 (0.12)
R-50.0 (8.81)	R-58.1 (10.24)	0.017 (0.10)

Parapet Linear Transmittance

Roof Insulation 1D R-Value (RSI)	R-15 Wall Insulation			R-20 Wall Insulation			R-25 Wall Insulation		
	R ft ² ·hr·°F/Btu (m ² K/W)	U Btu/ft ² ·hr ·°F (W/m ² K)	ψ Btu/ft ·hr·°F (W/m K)	R ft ² ·hr·°F/Btu (m ² K/W)	U Btu/ft ² ·hr ·°F (W/m ² K)	ψ Btu/ft ·hr·°F (W/m K)	R ft ² ·hr·°F/Btu (m ² K/W)	U Btu/ft ² ·hr ·°F (W/m ² K)	ψ Btu/ft ·hr·°F (W/m K)
R-20.0 (3.52)	R-24.2 (4.27)	0.041 (0.23)	0.030 (0.053)	R-26.4 (4.64)	0.038 (0.22)	0.030 (0.051)	R-28.1 (4.95)	0.036 (0.20)	0.029 (0.051)
R-30.0 (5.28)	R-27.4 (4.83)	0.036 (0.21)	0.029 (0.051)	R-30.2 (5.31)	0.033 (0.19)	0.028 (0.049)	R-32.5 (5.72)	0.031 (0.17)	0.028 (0.048)
R-40.0 (7.04)	R-29.6 (5.22)	0.034 (0.19)	0.029 (0.050)	R-32.9 (5.80)	0.030 (0.17)	0.027 (0.047)	R-35.8 (6.30)	0.028 (0.16)	0.026 (0.046)
R-50.0 (8.81)	R-31.3 (5.51)	0.032 (0.18)	0.029 (0.050)	R-35.0 (6.16)	0.029 (0.16)	0.027 (0.047)	R-38.3 (6.74)	0.026 (0.15)	0.026 (0.045)

Temperature Indices

	R15 Wall / R20 Roof	R20 Wall / R30 Roof	R25 Wall / R50 Roof	
T_{i1}	0.74	0.78	0.82	Min T on CLT, at wall to roof corner
T_{i2}	0.92	0.93	0.94	Max T on CLT on wall away from corner

Temperature indices for all other scenarios can be interpolated



Detail 8.5.1

Exterior and Interior Insulated 2x6 Wood Stud (16" o.c.) Wall Assembly with Wood Strapping Supporting and Continuous Insulation Fiber Cement Board and R-19 Batt Insulation in Stud Cavity – Corner Intersection

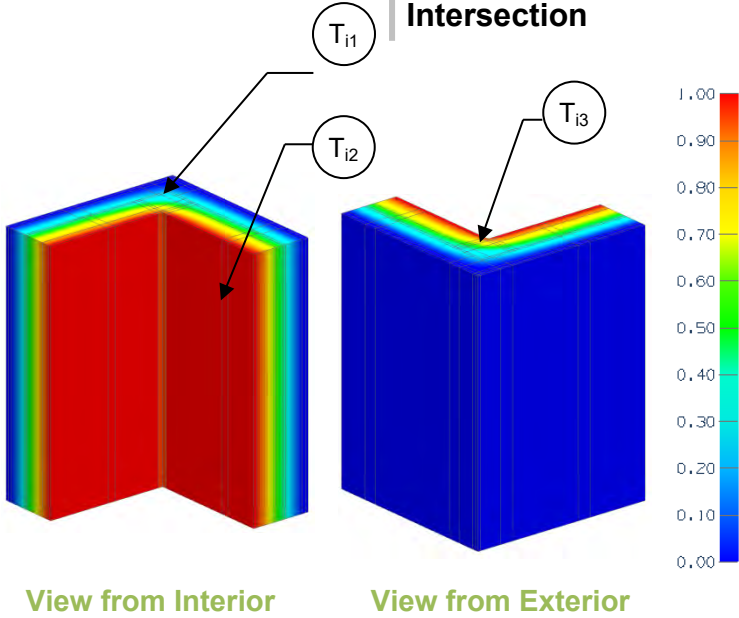

Thermal Performance Indicators

Assembly 1D (Nominal) R-Value	R_{1D}	R-21.6 (3.80 RSI) + exterior insulation
Transmittance / Resistance without Anomaly	U_o, R_o	"clear wall" U- and R-value, without corner
Transmittance / Resistance	U, R	U and R-values for the overall assembly
Surface Temperature Index ¹	T_i	0 = exterior temperature 1 = interior temperature
Linear Transmittance	ψ	Incremental increase in transmittance per linear length of corner

¹Assumptions and limitations for surface temperatures identified in ASHRAE 1365-RP

Nominal (1D) vs. Assembly Performance Indicators

Exterior Insulation 1D R-Value (RSI)	R_{1D} ft ² ·hr·°F / Btu (m ² K / W)	R_o ft ² ·hr·°F / Btu (m ² K / W)	U_o Btu/ft ² ·hr ·°F (W/m ² K)	R ft ² ·hr·°F / Btu (m ² K / W)	U Btu/ft ² ·hr ·°F (W/m ² K)	ψ Btu/ft ·hr·°F (W/m K)
R-0 (0)	R-21.7 (3.82)	R-19.7 (3.47)	0.051 (0.29)	R-17.9 (3.15)	0.056 (0.32)	0.020 (0.035)
R-5 (0.88)	R-26.6 (4.68)	R-24.6 (4.33)	0.041 (0.23)	R-21.8 (3.85)	0.046 (0.26)	0.020 (0.034)
R-15 (2.64)	R-36.6 (6.44)	R-33.7 (5.93)	0.030 (0.17)	R-28.6 (5.03)	0.035 (0.20)	0.021 (0.036)

Temperature Indices

	R0	R5	R15	
T_{i1}	-	0.10	0.19	Min T on sheathing, at fasteners at corner intersection
T_{i2}	0.13	0.32	0.49	Max T on sheathing, along studs between fasteners
T_{i3}	0.02	-	-	Min T on sheathing, at corner intersection

Detail 8.5.2

Interior Insulated Double Framed Wall 2x6 and 2x4 Wood Stud (16" o.c.) Wall Assembly with 1" Gap – Corner Intersection

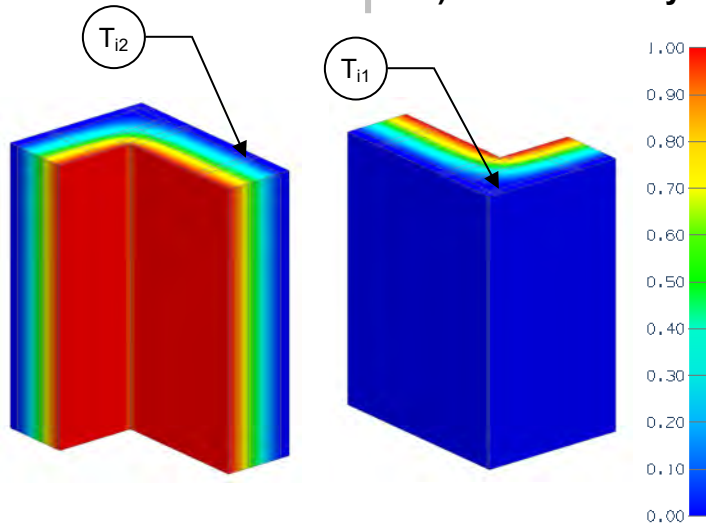

View from Interior

View from Exterior

Thermal Performance Indicators

Assembly 1D (Nominal) R-Value	R_{1D}	R-2.5 (0.44 RSI) + fill insulation
Transmittance / Resistance without Anomaly	U_o, R_o	"clear wall" U- and R-value, without corner
Transmittance / Resistance	U, R	U and R-values for the overall assembly
Surface Temperature Index ¹	T_i	0 = exterior temperature 1 = interior temperature
Linear Transmittance	ψ	Incremental increase in transmittance per linear length of corner

¹Assumptions and limitations for surface temperatures identified in ASHRAE 1365-RP

Nominal (1D) vs. Assembly Performance Indicators

Fill Insulation 1D R-Value (RSI)	R_{1D} ft ² ·hr·°F / Btu (m ² K / W)	R_o ft ² ·hr·°F / Btu (m ² K / W)	U_o Btu/ft ² ·hr ·°F (W/m ² K)	R ft ² ·hr·°F / Btu (m ² K / W)	U Btu/ft ² ·hr ·°F (W/m ² K)	ψ Btu/ft ·hr·°F (W/m K)
R-35.0 (6.16)	R-37.5 (6.61)	R-34.5 (6.07)	0.029 (0.16)	R-28.4 (5.01)	0.035 (0.20)	0.020 (0.034)
R-40.0 (7.04)	R-42.5 (7.49)	R-38.3 (6.74)	0.026 (0.15)	R-31.3 (5.52)	0.032 (0.18)	0.019 (0.032)
R-50.0 (8.81)	R-52.5 (9.25)	R-45.6 (8.02)	0.022 (0.12)	R-36.8 (6.48)	0.027 (0.15)	0.017 (0.029)
R-60.0 (10.57)	R-62.5 (11.01)	R-52.5 (9.24)	0.019 (0.11)	R-41.8 (7.36)	0.024 (0.14)	0.016 (0.027)

Temperature Indices

	R35	R40	R50	R60	
T_{i1}	0.01	0.01	0.01	0.01	Min T on sheathing, at corner intersection, beside studs
T_{i2}	0.08	0.08	0.07	0.07	Max T on sheathing, at studs

Detail 8.6.1

Wood-frame Sliding Door – Concrete Floor Intersection for Unheated Spaces (Parking Garages)

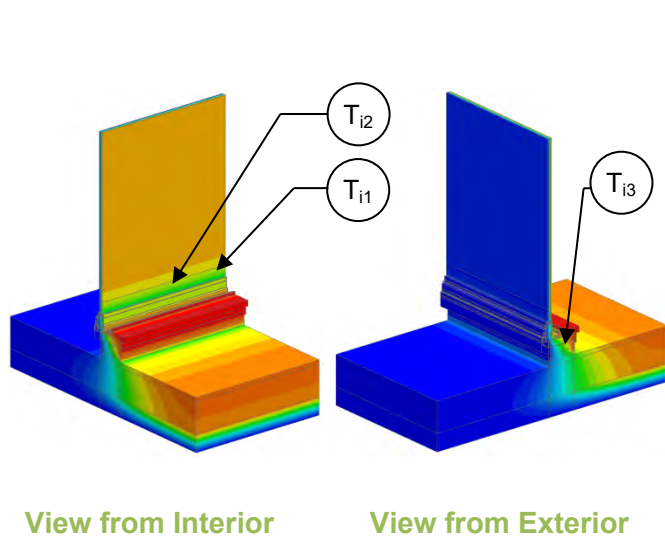

Thermal Performance Indicators

Assembly 1D (Nominal) R-Value	R_{1D}	R-2.3 (0.41 RSI) + Insulation
Transmittance / Resistance without Anomaly	U_f , R_f , U_g	“clear field” U- and R-value f = floor g = glazed sliding door
Transmittance / Resistance	U, R	U and R-values for the overall assembly
Surface Temperature Index ¹	T_i	0 = exterior temperature 1 = interior temperature
Linear Transmittance	ψ	Incremental increase in transmittance per linear length of floor to sliding door transition

¹Assumptions and limitations for surface temperatures identified in ASHRAE 1365-RP

Nominal (1D) vs. Assembly Performance Indicators

Base Assembly – Floor

Floor Exterior Insulation 1D R-Value (RSI)	R_{1D} ft ² ·hr·°F / Btu (m ² K / W)	R_f ft ² ·hr·°F / Btu (m ² K / W)	U_f Btu/ft ² ·hr·°F (W/m ² K)
R-20 (3.52)	R-22.3 (3.93)	R-22.3 (3.93)	0.044 (0.25)

Base Assembly – Sliding Door

$U_{\text{centre of glass}}$ Btu/ft ² ·hr·°F (W/m ² K)	U_g Btu/ft ² ·hr·°F (W/m ² K)
0.321 (1.82)	0.323 (1.83)

Sliding Door Sill/ Curb to Floor Linear Transmittance

Wall Exterior Insulation 1D R-Value (RSI)	R ft ² ·hr·°F / Btu (m ² K / W)	U Btu/ft ² ·hr·°F (W/m ² K)	ψ Btu/ft·hr·°F (W/m K)
R-20 (3.52)	R-3.5 (0.621)	0.284 (1.61)	0.320 (0.554)

Temperature Indices

T_{i1}	0.47	-	Min T on glass
T_{i2}	0.42	0.13	Min T on frame
T_{i3}	0.55	0.02	Min T on floor, at interior surface of wood curb

Detail 8.6.2

Exterior and Interior Insulated 2x6 Wood Stud (16" o.c.) Wall Assembly with Continuous Insulation and Wood Strapping Supporting Fiber Cement Board and R-19 Batt Insulation in Stud Cavity – Rim Joist and Interior Insulated At-Grade Foundation Wall Intersection

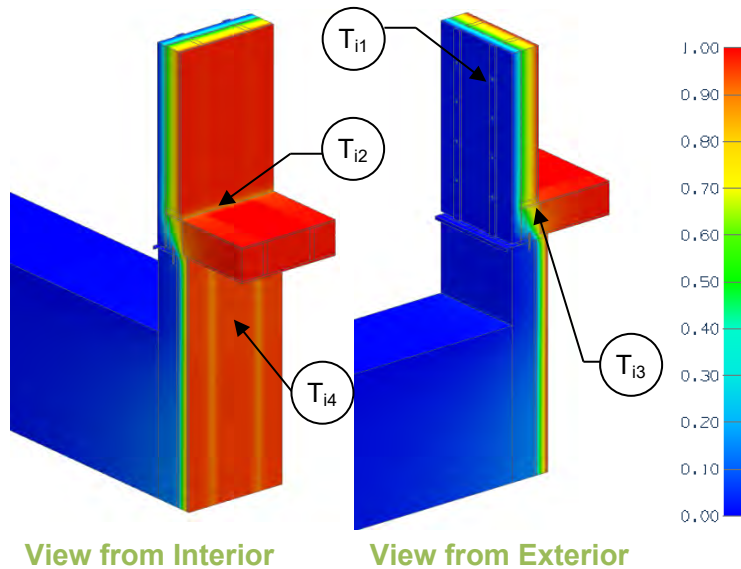

Thermal Performance Indicators

Assembly 1D (Nominal) R-Value	R_{1Dw} , R_{1Dfw}	R-21.6 (3.80 RSI) + exterior insulation for wood framed wall R-1.8 (0.32 RSI) + interior insulation for foundation w = wood framed wall fw = foundation wall
Transmittance / Resistance without Anomaly	U_w , R_w , U_{fw} , R_{fw}	"clear field" U- and R-values
Transmittance / Resistance	U, R	U and R-values for the overall assembly
Surface Temperature Index ¹	T_i	0 = exterior temperature 1 = interior temperature
Linear Transmittance	ψ	Incremental increase in transmittance per linear length of foundation

¹Assumptions and limitations for surface temperatures identified in ASHRAE 1365-RP

Nominal (1D) vs. Assembly Performance Indicators

Base Assembly – Wall

Exterior Insulation 1D R-Value (RSI)	R_{1Dw} ft ² ·hr·°F / Btu (m ² K / W)	R_w ft ² ·hr·°F / Btu (m ² K / W)	U_w Btu/ft ² ·hr·°F (W/m ² K)
R-5 (0.88)	R-26.6 (4.68)	R-24.6 (4.32)	0.041 (0.23)
R-10 (1.76)	R-31.6 (5.56)	R-29.2 (5.14)	0.034 (0.19)
R-15 (2.64)	R-36.6 (6.44)	R-33.7 (5.93)	0.030 (0.17)

Base Assembly – Foundation Wall

Foundation Insulation 1D R-Value (RSI)	R_{1Dfw} ft ² hr °F / Btu (m ² K / W)	R_{fw} ft ² ·hr·°F / Btu (m ² K / W)	U_{fw} Btu/ft ² ·hr·°F (W/m ² K)
R-19 (3.34)	R-20.8 (3.67)	R-12.7 (2.23)	0.079 (0.449)

Foundation Linear Transmittance

Exterior Insulation 1D R-Value (RSI)	R ft ² ·hr·°F / Btu (m ² K / W)	U Btu/ft ² ·hr·°F (W/m ² K)	ψ Btu/ft·hr·°F (W/m K)
R-5 (0.88)	R-15.9 (2.81)	0.063 (0.36)	0.046 (0.080)
R-10 (1.76)	R-16.7 (2.94)	0.060 (0.34)	0.047 (0.082)
R-15 (2.64)	R-17.2 (3.03)	0.058 (0.33)	0.050 (0.087)

Temperature Indices

	R5	R10	R15	
T_{i1}	0.25	0.36	0.43	Min T on sheathing, along studs at fasteners
T_{i2}	0.40	0.49	0.55	Max T on sheathing, along studs between fasteners and at bottom plate
T_{i3}	0.10	0.11	0.12	Min T on floor foundation sill plate, at rim joist
T_{i4}	0.07	0.07	0.07	Min T on foundation wall, at midsection between floor and grade between studs

Detail 8.6.3

Exterior and Interior Insulated 2x6 Wood Stud (16" o.c.) Wall Assembly with Continuous Insulation and Wood Strapping Supporting Fiber Cement Board and R-19 Batt Insulation in Stud Cavity – Rim Joist and Exterior Insulated At-Grade Foundation Wall Intersection

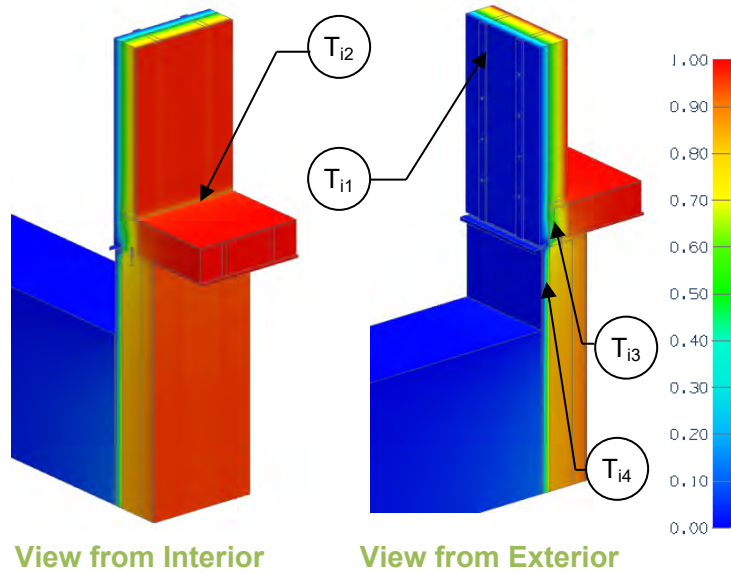

Thermal Performance Indicators

Assembly 1D (Nominal) R-Value	R_{1Dw} , R_{1Dfw}	R-21.6 (3.80 RSI) + exterior insulation for wood framed wall R-3.5 (0.62 RSI) + insulation for foundation w = wood framed wall fw = foundation wall
Transmittance / Resistance without Anomaly	U_w , R_w , U_{fw} , R_{fw}	"clear field" U- and R-value
Transmittance / Resistance	U, R	U and R-values for the overall assembly
Surface Temperature Index ¹	T_i	0 = exterior temperature 1 = interior temperature
Linear Transmittance	ψ	Incremental increase in transmittance per linear length of foundation

¹Assumptions and limitations for surface temperatures identified in ASHRAE 1365-RP

Nominal (1D) vs. Assembly Performance Indicators

Base Assembly – Wall

Base Assembly – Foundation Wall

Exterior Insulation 1D R-Value (RSI)	R_{1Dw} ft ² ·hr·°F / Btu (m ² K / W)	R_w ft ² ·hr·°F / Btu (m ² K / W)	U_w Btu/ft ² ·hr·°F (W/m ² K)
R-5 (0.88)	R-26.6 (4.68)	R-24.6 (4.32)	0.041 (0.23)
R-10 (1.76)	R-31.6 (5.56)	R-29.2 (5.14)	0.034 (0.19)
R-15 (2.64)	R-36.6 (6.44)	R-33.7 (5.93)	0.030 (0.17)

Foundation Insulation 1D R-Value (RSI)	R_{1Dfw} ft ² hr °F / Btu (m ² K / W)	R_{fw} ft ² ·hr·°F / Btu (m ² K / W)	U_{fw} Btu/ft ² ·hr·°F (W/m ² K)
R-12.5 (2.20)	R-16.0 (2.82)	R-16.0 (2.82)	0.062 (0.355)

Foundation Linear Transmittance

Exterior Insulation 1D R-Value (RSI)	R ft ² ·hr·°F / Btu (m ² K / W)	U Btu/ft ² ·hr·°F (W/m ² K)	ψ Btu/ft·hr·°F (W/m K)
R-5 (0.88)	R-18.0 (3.16)	0.056 (0.32)	0.060 (0.104)
R-10 (1.76)	R-19.0 (3.34)	0.053 (0.30)	0.059 (0.102)
R-15 (2.64)	R-19.7 (3.47)	0.051 (0.29)	0.059 (0.103)

Temperature Indices

	R5	R10	R15	
T_{i1}	0.25	0.36	0.43	Min T on sheathing, along studs at fasteners
T_{i2}	0.39	0.49	0.55	Max T on sheathing, along studs between fasteners and at bottom plate
T_{i3}	0.48	0.50	0.51	Min T on floor foundation sill plate, at rim joist
T_{i4}	0.82	0.82	0.82	Min T on foundation wall, at midsection between floor and grade between studs



Detail 8.6.4

Exterior and Interior Insulated 2x6 Wood Stud (16" o.c.) Wall Assembly with Shelf Angle & Brick Ties Supporting Brick Veneer and R-19 Batt Insulation in Stud Cavity – Exterior Insulated At-Grade Foundation Wall Intersection

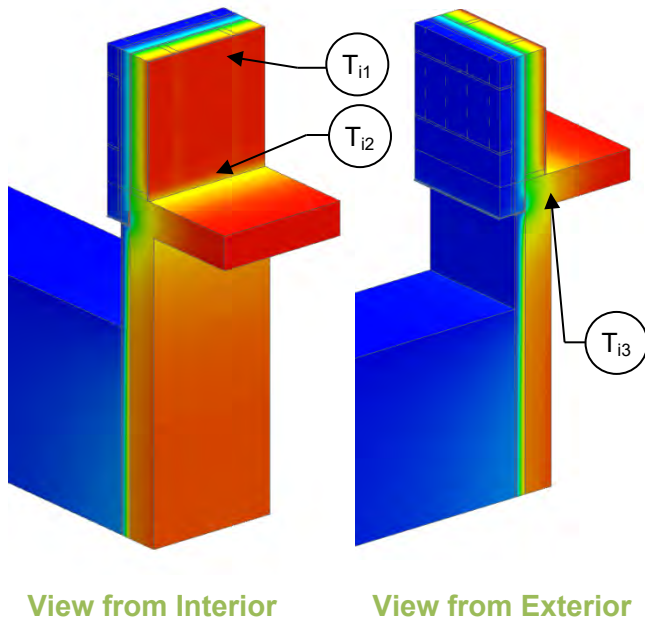

Thermal Performance Indicators

Assembly 1D (Nominal) R-Value	R_{1Dw} , R_{1Dfw}	R-27.4 (4.83 RSI) + exterior insulation for wood framed wall R-1.3 (0.29 RSI) + insulation for foundation w = wood framed wall fw = foundation wall
Transmittance / Resistance without Anomaly	U_w , R_w , U_{fw} , R_{fw}	"clear wall" U- and R-value
Transmittance / Resistance	U, R	U and R-values for the overall assembly
Surface Temperature Index ¹	T_i	0 = exterior temperature 1 = interior temperature
Linear Transmittance	ψ	Incremental increase in transmittance per linear length of foundation

¹Assumptions and limitations for surface temperatures identified in ASHRAE 1365-RP

Nominal (1D) vs. Assembly Performance Indicators

Base Assembly – Wall

Exterior Insulation 1D R-Value (RSI)	R_{1Dw} ft ² ·hr·°F / Btu (m ² K / W)	R_w ft ² ·hr·°F / Btu (m ² K / W)	U_w Btu/ft ² ·hr·°F (W/m ² K)
R-5 (0.88)	R-32.4 (5.71)	R-24.1 (4.25)	0.041 (0.24)
R-10 (1.76)	R-37.4 (6.59)	R-28.0 (4.93)	0.036 (0.20)
R-15 (2.64)	R-42.4 (7.47)	R-31.5 (5.54)	0.032 (0.18)

Base Assembly – Foundation Wall

Foundation Insulation 1D R-Value (RSI)	R_{1Dfw} ft ² hr °F / Btu (m ² K / W)	R_{fw} ft ² ·hr·°F / Btu (m ² K / W)	U_{fw} Btu/ft ² ·hr·°F (W/m ² K)
R-12.5 (2.20)	R-13.8 (2.43)	R-13.8 (2.43)	0.072 (0.412)

Foundation Linear Transmittance

Exterior Insulation 1D R-Value (RSI)	R ft ² ·hr·°F / Btu (m ² K / W)	U Btu/ft ² ·hr·°F (W/m ² K)	ψ Btu/ft·hr·°F (W/m K)
R-5 (0.88)	R-8.7 (1.53)	0.115 (0.66)	0.493 (0.853)
R-10 (1.76)	R-8.8 (1.54)	0.114 (0.65)	0.509 (0.881)
R-15 (2.64)	R-8.8 (1.55)	0.114 (0.65)	0.523 (0.905)

Temperature Indices

	R5	R10	R15	
T_{i1}	0.19	0.24	0.27	Min T on sheathing, at brick ties adjacent to the studs
T_{i2}	0.50	0.51	0.51	Max T on sheathing, at concrete floor intersection
T_{i3}	0.78	0.78	0.78	Min T on foundation wall, at floor intersection

Detail 8.6.5

Exterior Insulated Cross Laminated Timber (CLT) Wall Assembly with Continuous Rigid Insulation Supporting Fiber Cement Board – Concrete Slab and Exterior Insulated At-Grade Foundation Wall Intersection

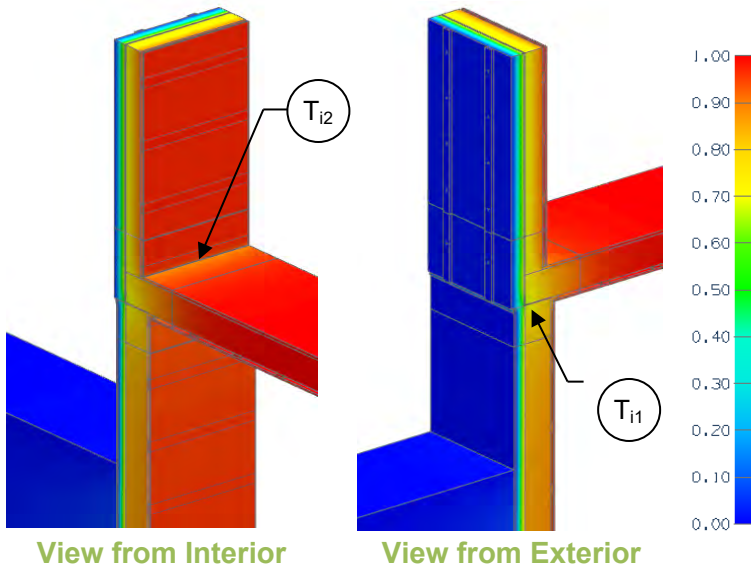

Thermal Performance Indicators

Assembly 1D (Nominal) R-Value	R_{1DCLT} , R_{1Dfw}	R-9.9 (1.74 RSI) + exterior insulation for CLT wall R-3.6 (0.64 RSI) + insulation for foundation CLT = CLT wall fw = foundation wall
Transmittance / Resistance without Anomaly	U_{CLT} , R_{CLT} , U_{fw} , R_{fw}	“clear field” U- and R-value
Transmittance / Resistance	U, R	U and R-values for the overall assembly
Surface Temperature Index ¹	T_i	0 = exterior temperature 1 = interior temperature
Linear Transmittance	ψ	Incremental increase in transmittance per linear length of foundation

¹Assumptions and limitations for surface temperatures identified in ASHRAE 1365-RP

Nominal (1D) vs. Assembly Performance Indicators

Base Assembly – Above Grade Wall

Exterior Insulation 1D R-Value (RSI)	R_{1DCLT} ft ² ·hr·°F / Btu (m ² K / W)	R_{CLT} ft ² ·hr·°F / Btu (m ² K / W)	U_{CLT} Btu/ft ² ·hr ·°F (W/m ² K)
R-15.0 (2.64)	R-24.9 (4.38)	R-24.7 (4.35)	0.040 (0.23)
R-20.0 (3.52)	R-29.9 (5.26)	R-29.4 (5.17)	0.034 (0.19)
R-25.0 (4.40)	R-34.9 (6.14)	R-33.9 (5.98)	0.029 (0.17)

Base Assembly – Foundation Wall

Foundation Insulation 1D R-Value (RSI)	R_{1Dfw} ft ² hr °F / Btu (m ² K / W)	R_{fw} ft ² ·hr·°F / Btu (m ² K / W)	U_{fw} Btu/ft ² ·hr ·°F (W/m ² K)
R-5.0 (0.88)	R-8.6 (1.52)	R-8.3 (1.46)	0.121 (0.69)
R-10.0 (1.76)	R-11.5 (2.03)	R-13.3 (2.34)	0.075 (0.43)
R-15.0 (2.64)	R-17.0 (3.00)	R-18.3 (3.22)	0.055 (0.31)
R-20.0 (3.52)	R-23.0 (4.05)	R-23.3 (4.10)	0.043 (0.24)

Foundation Linear Transmittance

Foundation Insulation 1D R-Value (RSI)	R-15 Wall Insulation			R-20 Wall Insulation			R-25 Wall Insulation		
	R ft ² ·hr·°F/Btu (m ² K/W)	U Btu/ft ² ·hr ·°F (W/m ² K)	ψ Btu/ft ·hr·°F (W/m K)	R ft ² ·hr·°F/Btu (m ² K/W)	U Btu/ft ² ·hr ·°F (W/m ² K)	ψ Btu/ft ·hr·°F (W/m K)	R ft ² ·hr·°F/Btu (m ² K/W)	U Btu/ft ² ·hr ·°F (W/m ² K)	ψ Btu/ft ·hr·°F (W/m K)
R-5.0 (0.88)	R-10.7 (1.89)	0.093 (0.53)	0.365 (0.632)	R-11.0 (1.95)	0.091 (0.51)	0.344 (0.595)	R-11.3 (1.99)	0.089 (0.50)	0.330 (0.570)
R-10.0 (1.76)	R-14.3 (2.51)	0.070 (0.40)	0.337 (0.584)	R-14.8 (2.61)	0.067 (0.38)	0.315 (0.545)	R-15.2 (2.68)	0.066 (0.37)	0.300 (0.519)
R-15.0 (2.64)	R-16.9 (2.98)	0.059 (0.34)	0.320 (0.555)	R-17.8 (3.14)	0.056 (0.32)	0.296 (0.512)	R-18.5 (3.25)	0.054 (0.31)	0.280 (0.484)
R-20.0 (3.52)	R-18.9 (3.32)	0.053 (0.30)	0.318 (0.551)	R-20.3 (3.58)	0.049 (0.28)	0.282 (0.488)	R-21.2 (3.73)	0.047 (0.27)	0.264 (0.457)

Temperature Indices

	R15 Wall / R5 Foundation	R20 Wall / R15 Foundation	R25 Wall / R20 Foundation	
T_{i1}	0.76	0.82	0.85	Min T on floor at CLT
T_{i2}	0.74	0.84	0.87	Min T on foundation wall, at midsection between floor and grade between wood strapping

Temperature indices for all other scenarios can be interpolated



Detail 8.6.6

Interior Insulated Double Framed Wall 2x6 and 2x4 Wood Stud (16" o.c.) Wall Assembly with 2" Gap – Rim Joist and Split Insulated At-Grade Foundation Wall Intersection

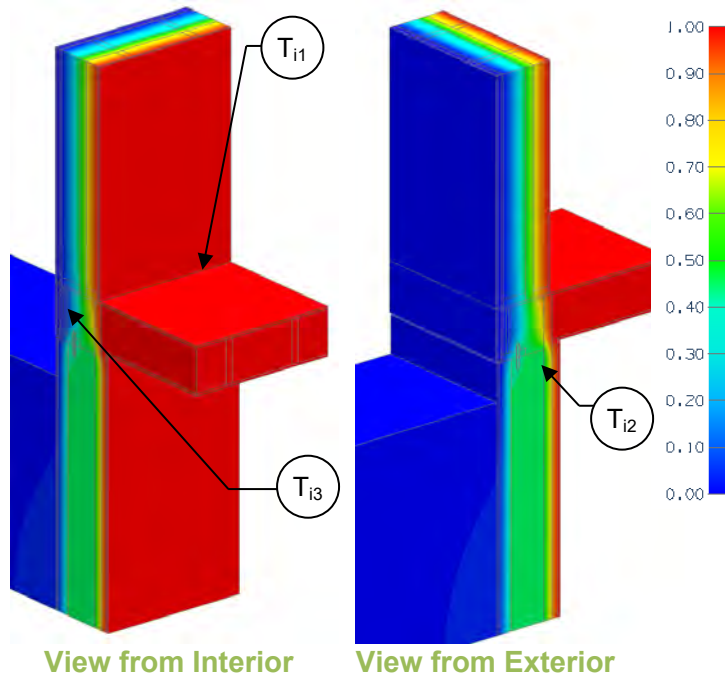

Thermal Performance Indicators

Assembly 1D (Nominal) R-Value	R_{1Dw} , R_{1Dfw}	R-2.5 (0.44 RSI) + exterior insulation for double framed wall R-6.6 (1.15 RSI) + insulation for foundation w = double framed wall fw = foundation wall
Transmittance / Resistance without Anomaly	U_w , R_w , U_{fw} , R_{fw}	"clear field" U- and R-value
Transmittance / Resistance	U, R	U and R-values for the overall assembly
Surface Temperature Index ¹	T_i	0 = exterior temperature 1 = interior temperature
Linear Transmittance	ψ	Incremental increase in transmittance per linear length of foundation

¹Assumptions and limitations for surface temperatures identified in ASHRAE 1365-RP

Nominal (1D) vs. Assembly Performance Indicators

Base Assembly – Above Grade Wall

Fill Insulation 1D R-Value (RSI)	R_{1D} ft ² ·hr·°F / Btu (m ² K / W)	R_w ft ² ·hr·°F / Btu (m ² K / W)	U_w Btu/ft ² ·hr·°F (W/m ² K)
R-38.5 (6.78)	R-41.0 (7.23)	R-38.0 (6.70)	0.026 (0.15)
R-44.0 (7.75)	R-46.5 (8.19)	R-42.4 (7.47)	0.024 (0.13)
R-55.0 (9.69)	R-57.5 (10.13)	R-50.8 (8.94)	0.020 (0.11)
R-66.0 (11.62)	R-68.5 (12.07)	R-58.9 (10.37)	0.017 (0.10)

Base Assembly – Foundation Wall

Foundation Insulation 1D R-Value (RSI)	R_{1Dfw} ft ² hr °F / Btu (m ² K / W)	R_{fw} ft ² ·hr·°F / Btu (m ² K / W)	U_{fw} Btu/ft ² ·hr·°F (W/m ² K)
R-32.5 (5.72)	R-39.1 (6.88)	R-34.1 (6.01)	0.029 (0.17)

Foundation Linear Transmittance

Fill Insulation 1D R-Value (RSI)	R_{1D} ft ² ·hr·°F / Btu (m ² K / W)	R ft ² ·hr·°F / Btu (m ² K / W)	U Btu/ft ² ·hr·°F (W/m ² K)	ψ Btu/ft·hr·°F (W/m K)
R-38.5 (6.78)	R-41.0 (7.23)	R-35.5 (6.26)	0.028 (0.16)	0.010 (0.017)
R-44.0 (7.75)	R-46.5 (8.19)	R-37.2 (6.55)	0.027 (0.15)	0.011 (0.019)
R-55.0 (9.69)	R-57.5 (10.13)	R-39.9 (7.03)	0.025 (0.14)	0.013 (0.022)
R-66.0 (11.62)	R-68.5 (12.07)	R-42.0 (7.40)	0.024 (0.14)	0.014 (0.024)

Temperature Indices

	R38.5	R44.0	R55.0	R66.0	
T_{i1}	0.93	0.93	0.93	0.94	Min T on gypsum, at studs on floor
T_{i2}	0.47	0.47	0.47	0.47	Min T on foundation wall, at midsection between floor and grade between studs
T_{i3}	0.10	0.09	0.08	0.07	Min T on rim joist, between floor joists

Temperature indices for all other scenarios can be interpolated



Detail 8.6.7

Interior Insulated Double Framed Wall 2x6 and 2x4 Wood Stud (16" o.c.) Wall Assembly with 2" Gap – Insulated Rim Joist and Split Insulated At-Grade Foundation Wall Intersection

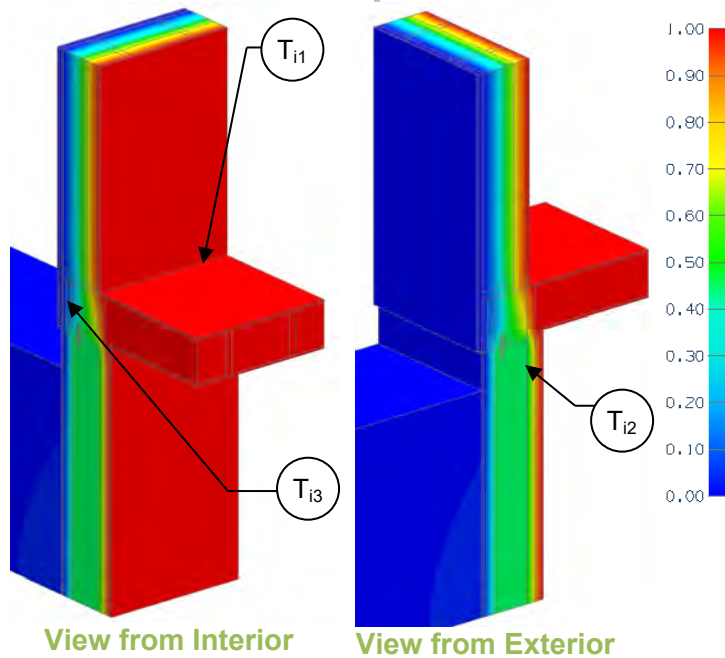

Thermal Performance Indicators

Assembly 1D (Nominal) R-Value	R_{1Dw} , R_{1Dfw}	R-2.5 (0.44 RSI) + exterior insulation for double framed wall R-6.6 (1.15 RSI) + insulation for foundation w = double framed wall fw = foundation wall
Transmittance / Resistance without Anomaly	U_w , R_w , U_{fw} , R_{fw}	"clear field" U- and R-value
Transmittance / Resistance	U, R	U and R-values for the overall assembly
Surface Temperature Index ¹	T_i	0 = exterior temperature 1 = interior temperature
Linear Transmittance	ψ	Incremental increase in transmittance per linear length of foundation

¹Assumptions and limitations for surface temperatures identified in ASHRAE 1365-RP

Nominal (1D) vs. Assembly Performance Indicators

Base Assembly – Above Grade Wall

Fill Insulation 1D R-Value (RSI)	R_{1D} ft ² ·hr·°F / Btu (m ² K / W)	R_w ft ² ·hr·°F / Btu (m ² K / W)	U_w Btu/ft ² ·hr ·°F (W/m ² K)
R-38.5 (6.78)	R-41.0 (7.23)	R-38.0 (6.70)	0.026 (0.15)
R-44.0 (7.75)	R-46.5 (8.19)	R-42.4 (7.47)	0.024 (0.13)
R-55.0 (9.69)	R-57.5 (10.13)	R-50.8 (8.94)	0.020 (0.11)
R-66.0 (11.62)	R-68.5 (12.07)	R-58.9 (10.37)	0.017 (0.10)

Base Assembly – Foundation Wall

Foundation Insulation 1D R-Value (RSI)	R_{1Dfw} ft ² hr °F / Btu (m ² K / W)	R_{fw} ft ² ·hr·°F / Btu (m ² K / W)	U_{fw} Btu/ft ² ·hr ·°F (W/m ² K)
R-32.5 (5.72)	R-39.1 (6.88)	R-34.1 (6.01)	0.029 (0.17)

Foundation Linear Transmittance

Fill Insulation 1D R-Value (RSI)	R_{1D} ft ² ·hr·°F / Btu (m ² K / W)	R ft ² ·hr·°F / Btu (m ² K / W)	U Btu/ft ² ·hr ·°F (W/m ² K)	ψ Btu/ft ·hr ·°F (W/m K)
R-38.5 (6.78)	R-41.0 (7.23)	R-36.2 (6.37)	0.028 (0.16)	0.005 (0.009)
R-44.0 (7.75)	R-46.5 (8.19)	R-37.8 (6.66)	0.026 (0.15)	0.007 (0.012)
R-55.0 (9.69)	R-57.5 (10.13)	R-40.6 (7.15)	0.025 (0.14)	0.009 (0.015)
R-66.0 (11.62)	R-68.5 (12.07)	R-42.7 (7.53)	0.023 (0.13)	0.010 (0.018)

Temperature Indices

	R38.5	R44.0	R55.0	R66.0	
T_{11}	0.92	0.92	0.93	0.93	Min T on gypsum, at studs on floor
T_{12}	0.49	0.49	0.49	0.49	Min T on foundation wall, at midsection between floor and grade between studs
T_{13}	0.21	0.20	0.18	0.16	Min T on rim joist, between floor joists

Temperature indices for all other scenarios can be interpolated

Detail 8.6.8

Interior Insulated Double Framed Wall 2x6 and 2x4 Wood Stud (16" o.c.) Wall Assembly with 2" Gap and R28 ICF Foundation Wall – Rim Joist and Split Insulated At-Grade Foundation Wall Intersection

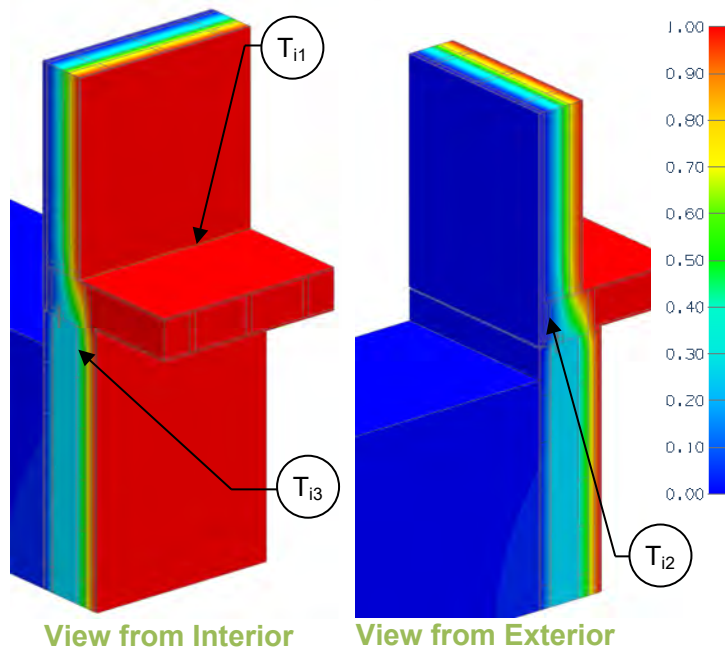

Thermal Performance Indicators

Assembly 1D (Nominal) R-Value	R_{1Dw} , R_{1Dfw}	R-2.5 (0.44 RSI) + exterior insulation for double framed wall R-7.1 (1.25 RSI) + insulation for foundation w = double framed wall fw = foundation wall
Transmittance / Resistance without Anomaly	U_w , R_w , U_{fw} , R_{fw}	"clear field" U- and R-value
Transmittance / Resistance	U, R	U and R-values for the overall assembly
Surface Temperature Index ¹	T_i	0 = exterior temperature 1 = interior temperature
Linear Transmittance	ψ	Incremental increase in transmittance per linear length of foundation

¹Assumptions and limitations for surface temperatures identified in ASHRAE 1365-RP

Nominal (1D) vs. Assembly Performance Indicators

Base Assembly – Above Grade Wall

Fill Insulation 1D R-Value (RSI)	R_{1D} ft ² ·hr·°F / Btu (m ² K / W)	R_w ft ² ·hr·°F / Btu (m ² K / W)	U_w Btu/ft ² ·hr ·°F (W/m ² K)
R-38.5 (6.78)	R-41.0 (7.23)	R-38.0 (6.70)	0.026 (0.15)
R-44.0 (7.75)	R-46.5 (8.19)	R-42.4 (7.47)	0.024 (0.13)
R-55.0 (9.69)	R-57.5 (10.13)	R-50.8 (8.94)	0.020 (0.11)
R-66.0 (11.62)	R-68.5 (12.07)	R-58.9 (10.37)	0.017 (0.10)

Base Assembly – Foundation Wall

Foundation Insulation 1D R-Value (RSI)	R_{1Dfw} ft ² hr °F / Btu (m ² K / W)	R_{fw} ft ² ·hr·°F / Btu (m ² K / W)	U_{fw} Btu/ft ² ·hr ·°F (W/m ² K)
R-42.5 (7.49)	R-49.6 (8.73)	R-43.9 (7.74)	0.023 (0.13)

Foundation Linear Transmittance

Fill Insulation 1D R-Value (RSI)	R_{1D} ft ² ·hr·°F / Btu (m ² K / W)	R ft ² ·hr·°F / Btu (m ² K / W)	U Btu/ft ² ·hr ·°F (W/m ² K)	ψ Btu/ft ·hr ·°F (W/m K)
R-38.5 (6.78)	R-41.0 (7.23)	R-41.0 (7.23)	0.024 (0.14)	0.004 (0.008)
R-44.0 (7.75)	R-46.5 (8.19)	R-43.1 (7.59)	0.023 (0.13)	0.006 (0.010)
R-55.0 (9.69)	R-57.5 (10.13)	R-46.5 (8.20)	0.021 (0.12)	0.007 (0.012)
R-66.0 (11.62)	R-68.5 (12.07)	R-49.2 (8.67)	0.020 (0.12)	0.008 (0.014)

Temperature Indices

	R38.5	R44.0	R55.0	R66.0	
T_{i1}	0.91	0.91	0.91	0.91	Min T on gypsum, at studs on floor
T_{i2}	0.33	0.33	0.33	0.32	Min T on foundation wall, at midsection between floor and grade between studs
T_{i3}	0.09	0.08	0.07	0.06	Min T on rim joist, between floor joists

Temperature indices for all other scenarios can be interpolated



Detail 8.6.9

Interior Insulated Double Framed Wall 2x6 and 2x4 Wood Stud (16" o.c.) Wall Assembly with 2" Gap and R43 ICF Foundation Wall – Rim Joist and Split Insulated At-Grade Foundation Wall Intersection

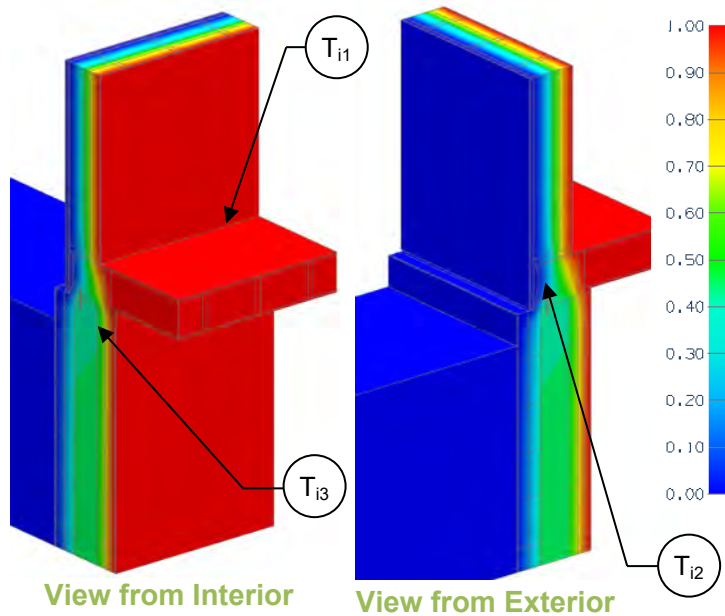

Thermal Performance Indicators

Assembly 1D (Nominal) R-Value	R_{1Dw} , R_{1Dfw}	R-2.5 (0.44 RSI) + exterior insulation for double framed wall R-7.1 (1.25 RSI) + insulation for foundation w = double framed wall fw = foundation wall
Transmittance / Resistance without Anomaly	U_w, R_w , U_{fw}, R_{fw}	“clear field” U- and R-value
Transmittance / Resistance	U, R	U and R-values for the overall assembly
Surface Temperature Index ¹	T_i	0 = exterior temperature 1 = interior temperature
Linear Transmittance	ψ	Incremental increase in transmittance per linear length of foundation

¹Assumptions and limitations for surface temperatures identified in ASHRAE 1365-RP

Nominal (1D) vs. Assembly Performance Indicators

Base Assembly – Above Grade Wall

Fill Insulation 1D R-Value (RSI)	R_{1D} ft ² ·hr·°F / Btu (m ² K / W)	R_w ft ² ·hr·°F / Btu (m ² K / W)	U_w Btu/ft ² ·hr ·°F (W/m ² K)
R-38.5 (6.78)	R-41.0 (7.23)	R-38.0 (6.70)	0.026 (0.15)
R-44.0 (7.75)	R-46.5 (8.19)	R-42.4 (7.47)	0.024 (0.13)
R-55.0 (9.69)	R-57.5 (10.13)	R-50.8 (8.94)	0.020 (0.11)
R-66.0 (11.62)	R-68.5 (12.07)	R-58.9 (10.37)	0.017 (0.10)

Base Assembly – Foundation Wall

Foundation Insulation 1D R-Value (RSI)	R_{1Dfw} ft ² hr °F / Btu (m ² K / W)	R_{fw} ft ² ·hr·°F / Btu (m ² K / W)	U_{fw} Btu/ft ² ·hr ·°F (W/m ² K)
R-58.5 (10.30)	R-65.6 (11.55)	R-60.2 (10.61)	0.017 (0.09)

Foundation Linear Transmittance

Fill Insulation 1D R-Value (RSI)	R_{1D} ft ² ·hr·°F / Btu (m ² K / W)	R ft ² ·hr·°F / Btu (m ² K / W)	U Btu/ft ² ·hr ·°F (W/m ² K)	ψ Btu/ft ·hr ·°F (W/m K)
R-38.5 (6.78)	R-41.0 (7.23)	R-45.8 (8.07)	0.022 (0.12)	0.009 (0.015)
R-44.0 (7.75)	R-46.5 (8.19)	R-48.4 (8.52)	0.021 (0.12)	0.010 (0.018)
R-55.0 (9.69)	R-57.5 (10.13)	R-52.7 (9.29)	0.019 (0.11)	0.012 (0.020)
R-66.0 (11.62)	R-68.5 (12.07)	R-56.2 (9.89)	0.018 (0.10)	0.013 (0.022)

Temperature Indices

	R38.5	R44.0	R55.0	R66.0	
T_{11}	0.91	0.91	0.92	0.92	Min T on gypsum, at studs on floor
T_{12}	0.44	0.44	0.44	0.44	Min T on foundation wall, at midsection between floor and grade between studs
T_{13}	0.10	0.09	0.07	0.07	Min T on rim joist, between floor joists

Temperature indices for all other scenarios can be interpolated



Detail 8.6.10 Interior Insulated Double Framed Wall 2x6 and 2x4 Wood Stud (16" o.c.) Wall Assembly with 2" Gap and Partially Wrapped R-22.5 Raft Slab Insulation – Slab on Grade Foundation Intersection

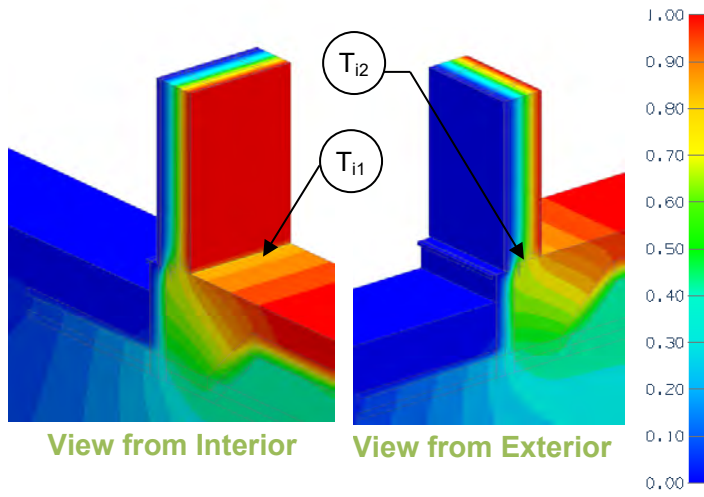

Thermal Performance Indicators

Assembly 1D (Nominal) R-Value	R_{1D}	R-2.5 (0.44 RSI) + exterior insulation for double framed wall
Transmittance / Resistance without Anomaly	U_w, R_w	"clear field" U- and R-value
Transmittance / Resistance	U, R	U and R-values for the overall assembly
Surface Temperature Index ¹	T_i	0 = exterior temperature 1 = interior temperature
Foundation Transmittance ²	L_{2Df}, L_{2Dt}	Heat loss of slab on grade per unit width of slab: f = floor t = floor + wall + foundation
Linear Transmittance	ψ	Incremental increase in transmittance per linear length of foundation

¹Assumptions and limitations for surface temperatures identified in ASHRAE 1365-RP

²For on grade transition calculation, see Appendix B introduction

Nominal (1D) vs. Assembly Performance Indicators

Base Assembly – Above Grade Wall

Fill Insulation 1D R-Value (RSI)	R_{1D} ft ² ·hr·°F / Btu (m ² K / W)	R_w ft ² ·hr·°F / Btu (m ² K / W)	U_w Btu/ft ² ·hr ·°F (W/m ² K)
R-38.5 (6.78)	R-41.0 (7.23)	R-38.0 (6.70)	0.026 (0.15)
R-44.0 (7.75)	R-46.5 (8.19)	R-42.4 (7.47)	0.024 (0.13)
R-55.0 (9.69)	R-57.5 (10.13)	R-50.8 (8.94)	0.020 (0.11)
R-66.0 (11.62)	R-68.5 (12.07)	R-58.9 (10.37)	0.017 (0.10)

Base Assembly – Foundation Wall

Foundation Insulation 1D R-Value (RSI)	L_{2Df} Btu/ft ·hr ·°F (W/m K))
R-22.5 (3.96)	1.015 (0.586)

Foundation Linear Transmittance

Fill Insulation 1D R-Value (RSI)	R_{1D} ft ² ·hr·°F / Btu (m ² K / W)	R ft ² ·hr·°F / Btu (m ² K / W)	U Btu/ft ² ·hr ·°F (W/m ² K)	L_{2Dt} Btu/ft ·hr ·°F (W/m K)	ψ Btu/ft ·hr ·°F (W/m K)
R-38.5 (6.78)	R-41.0 (7.23)	R-23.9 (4.21)	0.238 (1.35)	1.240 (0.717)	0.037 (0.022)
R-44.0 (7.75)	R-46.5 (8.19)	R-24.2 (4.27)	0.234 (1.33)	1.223 (0.706)	0.039 (0.023)
R-55.0 (9.69)	R-57.5 (10.13)	R-24.8 (4.36)	0.229 (1.30)	1.196 (0.691)	0.041 (0.024)
R-66.0 (11.62)	R-68.5 (12.07)	R-25.2 (4.43)	0.226 (1.28)	1.178 (0.681)	0.042 (0.024)

Temperature Indices

	R38.5	R44.0	R55.0	R66.0	
T_{i1}	0.78	0.78	0.78	0.78	Min T on gypsum, at studs on floor
T_{i2}	0.68	0.68	0.68	0.68	Min T on concrete floor, at edge

Temperature indices for all other scenarios can be interpolated



Detail 8.6.11

Interior Insulated Double Framed Wall 2x6 and 2x4 Wood Stud (16" o.c.) Wall Assembly with 2" Gap and Partially Wrapped R-45 Raft Slab Insulation – Slab on Grade Foundation Intersection

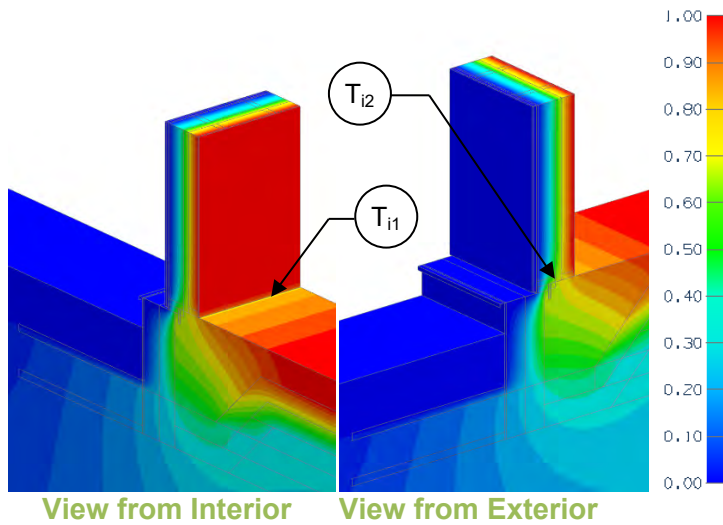

Thermal Performance Indicators

Assembly 1D (Nominal) R-Value	R_{1D}	R-2.5 (0.44 RSI) + exterior insulation for double framed wall
Transmittance / Resistance without Anomaly	U_w, R_w	"clear field" U- and R-value
Transmittance / Resistance	U, R	U and R-values for the overall assembly
Surface Temperature Index ¹	T_i	0 = exterior temperature 1 = interior temperature
Foundation Transmittance ²	L_{2Df}, L_{2Dt}	Heat loss of slab on grade per unit width of slab: f = floor t = floor + wall + foundation
Linear Transmittance	ψ	Incremental increase in transmittance per linear length of foundation

¹Assumptions and limitations for surface temperatures identified in ASHRAE 1365-RP

²For on grade transition calculation, see Appendix B introduction

Nominal (1D) vs. Assembly Performance Indicators

Base Assembly – Above Grade Wall

Fill Insulation 1D R-Value (RSI)	R_{1D} ft ² ·hr·°F / Btu (m ² K / W)	R_w ft ² ·hr·°F / Btu (m ² K / W)	U_w Btu/ft ² ·hr·°F (W/m ² K)
R-38.5 (6.78)	R-41.0 (7.23)	R-38.0 (6.70)	0.026 (0.15)
R-44.0 (7.75)	R-46.5 (8.19)	R-42.4 (7.47)	0.024 (0.13)
R-55.0 (9.69)	R-57.5 (10.13)	R-50.8 (8.94)	0.020 (0.11)
R-66.0 (11.62)	R-68.5 (12.07)	R-58.9 (10.37)	0.017 (0.10)

Base Assembly – Foundation Wall

Foundation Insulation 1D R-Value (RSI)	L_{2Df} Btu/ft·hr·°F (W/m K)
R-45.0 (7.93)	0.844 (0.488)

Foundation Linear Transmittance

Fill Insulation 1D R-Value (RSI)	R_{1D} ft ² ·hr·°F / Btu (m ² K / W)	R ft ² ·hr·°F / Btu (m ² K / W)	U Btu/ft ² ·hr·°F (W/m ² K)	L_{2Dt} Btu/ft·hr·°F (W/m K)	ψ Btu/ft·hr·°F (W/m K)
R-38.5 (6.78)	R-41.0 (7.23)	R-27.5 (4.84)	0.206 (1.17)	1.077 (0.622)	0.046 (0.026)
R-44.0 (7.75)	R-46.5 (8.19)	R-28.0 (4.93)	0.203 (1.15)	1.059 (0.612)	0.047 (0.027)
R-55.0 (9.69)	R-57.5 (10.13)	R-28.7 (5.05)	0.198 (1.12)	1.033 (0.597)	0.048 (0.028)
R-66.0 (11.62)	R-68.5 (12.07)	R-29.2 (5.14)	0.194 (1.10)	1.015 (0.586)	0.049 (0.029)

Temperature Indices

	R38.5	R44.0	R55.0	R66.0	
T_{i1}	0.78	0.78	0.78	0.78	Min T on gypsum, at studs on floor
T_{i2}	0.68	0.68	0.68	0.68	Min T on concrete floor, at edge

Temperature indices for all other scenarios can be interpolated

Detail 8.6.12

Interior Insulated Double Framed Wall 2x6 and 2x4 Wood Stud (16" o.c.) Wall Assembly with 2" Gap and Fully Wrapped R-22.5 Raft Slab Insulation – Slab on Grade Foundation Intersection

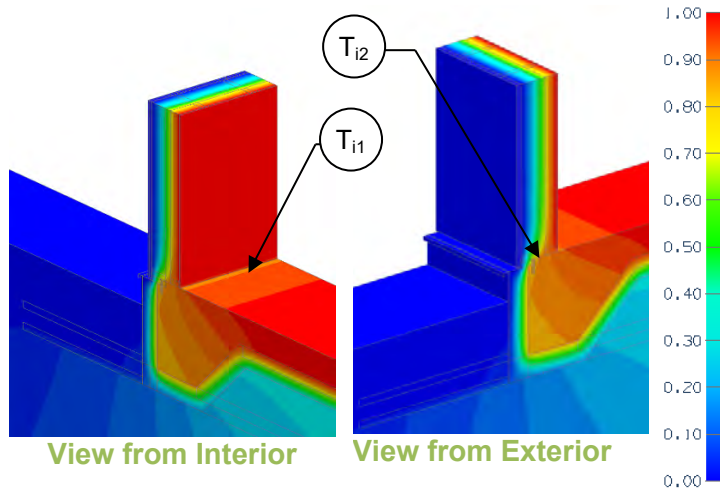

Thermal Performance Indicators

Assembly 1D (Nominal) R-Value	R_{1D}	R-2.5 (0.44 RSI) + exterior insulation for double framed wall
Transmittance / Resistance without Anomaly	U_w, R_w	"clear field" U- and R-value
Transmittance / Resistance	U, R	U and R-values for the overall assembly
Surface Temperature Index ¹	T_i	0 = exterior temperature 1 = interior temperature
Foundation Transmittance ²	L_{2Df}, L_{2Dt}	Heat loss of slab on grade per unit width of slab: f = floor t = floor + wall + foundation
Linear Transmittance	ψ	Incremental increase in transmittance per linear length of foundation

¹Assumptions and limitations for surface temperatures identified in ASHRAE 1365-RP

²For on grade transition calculation, see Appendix B introduction

Nominal (1D) vs. Assembly Performance Indicators

Base Assembly – Above Grade Wall

Fill Insulation 1D R-Value (RSI)	R_{1D} ft ² ·hr·°F / Btu (m ² K / W)	R_w ft ² ·hr·°F / Btu (m ² K / W)	U_w Btu/ft ² ·hr ·°F (W/m ² K)
R-38.5 (6.78)	R-41.0 (7.23)	R-38.0 (6.70)	0.026 (0.15)
R-44.0 (7.75)	R-46.5 (8.19)	R-42.4 (7.47)	0.024 (0.13)
R-55.0 (9.69)	R-57.5 (10.13)	R-50.8 (8.94)	0.020 (0.11)
R-66.0 (11.62)	R-68.5 (12.07)	R-58.9 (10.37)	0.017 (0.10)

Base Assembly – Foundation Wall

Foundation Insulation 1D R-Value (RSI)	L_{2Df} Btu/ft ·hr ·°F (W/m K)
R-22.5 (3.96)	0.753 (0.435)

Foundation Linear Transmittance

Fill Insulation 1D R-Value (RSI)	R_{1D} ft ² ·hr·°F / Btu (m ² K / W)	R ft ² ·hr·°F / Btu (m ² K / W)	U Btu/ft ² ·hr ·°F (W/m ² K)	L_{2Dt} Btu/ft ·hr ·°F (W/m K)	ψ Btu/ft ·hr ·°F (W/m K)
R-38.5 (6.78)	R-41.0 (7.23)	R-29.8 (5.25)	0.191 (1.08)	0.995 (0.575)	0.053 (0.031)
R-44.0 (7.75)	R-46.5 (8.19)	R-30.4 (5.35)	0.187 (1.06)	0.976 (0.564)	0.054 (0.031)
R-55.0 (9.69)	R-57.5 (10.13)	R-31.2 (5.50)	0.182 (1.03)	0.950 (0.549)	0.056 (0.032)
R-66.0 (11.62)	R-68.5 (12.07)	R-31.8 (5.60)	0.178 (1.01)	0.931 (0.538)	0.056 (0.033)

Temperature Indices

	R38.5	R44.0	R55.0	R66.0	
T_{i1}	0.87	0.87	0.88	0.88	Min T on gypsum, at studs on floor
T_{i2}	0.80	0.80	0.81	0.81	Min T on concrete floor, at edge

Temperature indices for all other scenarios can be interpolated



Detail 8.6.13

Interior Insulated Double Framed Wall 2x6 and 2x4 Wood Stud (16" o.c.) Wall Assembly with 2" Gap and Fully Wrapped R-45 Raft Slab Insulation – Slab on Grade Foundation Intersection

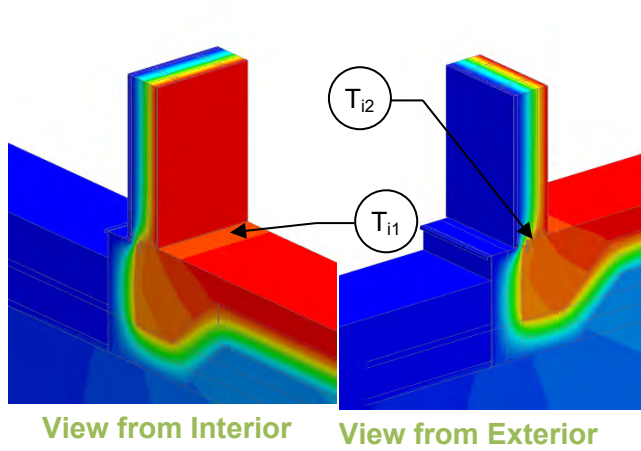

Thermal Performance Indicators

Assembly 1D (Nominal) R-Value	R_{1D}	R-2.5 (0.44 RSI) + exterior insulation for double framed wall
Transmittance / Resistance without Anomaly	U_w, R_w	"clear field" U- and R-value
Transmittance / Resistance	U, R	U and R-values for the overall assembly
Surface Temperature Index ¹	T_i	0 = exterior temperature 1 = interior temperature
Foundation Transmittance ²	L_{2Df}, L_{2Dt}	Heat loss of slab on grade per unit width of slab: f = floor t = floor + wall + foundation
Linear Transmittance	ψ	Incremental increase in transmittance per linear length of foundation

¹Assumptions and limitations for surface temperatures identified in ASHRAE 1365-RP

²For on grade transition calculation, see Appendix B introduction

Nominal (1D) vs. Assembly Performance Indicators

Base Assembly – Above Grade Wall

Fill Insulation 1D R-Value (RSI)	R_{1D} ft ² ·hr·°F / Btu (m ² K / W)	R_w ft ² ·hr·°F / Btu (m ² K / W)	U_w Btu/ft ² ·hr ·°F (W/m ² K)
R-38.5 (6.78)	R-41.0 (7.23)	R-38.0 (6.70)	0.026 (0.15)
R-44.0 (7.75)	R-46.5 (8.19)	R-42.4 (7.47)	0.024 (0.13)
R-55.0 (9.69)	R-57.5 (10.13)	R-50.8 (8.94)	0.020 (0.11)
R-66.0 (11.62)	R-68.5 (12.07)	R-58.9 (10.37)	0.017 (0.10)

Base Assembly – Foundation Wall

Foundation Insulation 1D R-Value (RSI)	L_{2Df} Btu/ft ·hr ·°F (W/m K)
R-45.0 (7.93)	0.474 (0.274)

Foundation Linear Transmittance

Fill Insulation 1D R-Value (RSI)	R_{1D} ft ² ·hr·°F / Btu (m ² K / W)	R ft ² ·hr·°F / Btu (m ² K / W)	U Btu/ft ² ·hr ·°F (W/m ² K)	L_{2Dt} Btu/ft ·hr ·°F (W/m K)	ψ Btu/ft ·hr ·°F (W/m K)
R-38.5 (6.78)	R-41.0 (7.23)	R-40.4 (7.12)	0.141 (0.80)	0.734 (0.424)	0.071 (0.041)
R-44.0 (7.75)	R-46.5 (8.19)	R-41.4 (7.30)	0.137 (0.78)	0.715 (0.413)	0.073 (0.042)
R-55.0 (9.69)	R-57.5 (10.13)	R-43.0 (7.58)	0.132 (0.75)	0.689 (0.398)	0.074 (0.043)
R-66.0 (11.62)	R-68.5 (12.07)	R-44.2 (7.79)	0.128 (0.73)	0.670 (0.387)	0.074 (0.043)

Temperature Indices

	R38.5	R44.0	R55.0	R66.0	
T_{i1}	0.90	0.90	0.90	0.90	Min T on gypsum, at studs on floor
T_{i2}	0.84	0.84	0.84	0.84	Min T on concrete floor, at edge

Temperature indices for all other scenarios can be interpolated



Detail 8.6.14 Interior Insulated Double Framed Wall 2x6 and 2x4 Wood Stud (16" o.c.) Wall Assembly with 2" Gap and R-22.5 Slab Insulation with Gravel Base – Slab on Grade Foundation Intersection

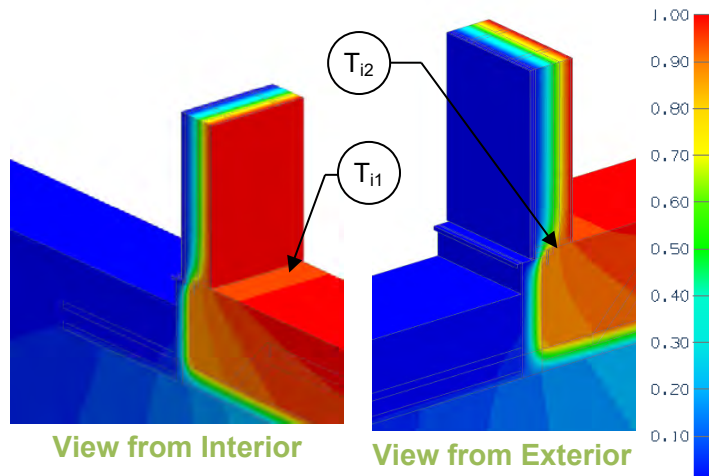

Thermal Performance Indicators

Assembly 1D (Nominal) R-Value	R_{1D}	R-2.5 (0.44 RSI) + exterior insulation for double framed wall
Transmittance / Resistance without Anomaly	U_w, R_w	"clear field" U- and R-value
Transmittance / Resistance	U, R	U and R-values for the overall assembly
Surface Temperature Index ¹	T_i	0 = exterior temperature 1 = interior temperature
Foundation Transmittance ²	L_{2Df}, L_{2Dt}	Heat loss of slab on grade per unit width of slab: f = floor t = floor + wall + foundation
Linear Transmittance	ψ	Incremental increase in transmittance per linear length of foundation

¹Assumptions and limitations for surface temperatures identified in ASHRAE 1365-RP

²For on grade transition calculation, see Appendix B introduction

Nominal (1D) vs. Assembly Performance Indicators

Base Assembly – Above Grade Wall

Fill Insulation 1D R-Value (RSI)	R_{1D} ft ² ·hr·°F / Btu (m ² K / W)	R_w ft ² ·hr·°F / Btu (m ² K / W)	U_w Btu/ft ² ·hr ·°F (W/m ² K)
R-38.5 (6.78)	R-41.0 (7.23)	R-38.0 (6.70)	0.026 (0.15)
R-44.0 (7.75)	R-46.5 (8.19)	R-42.4 (7.47)	0.024 (0.13)
R-55.0 (9.69)	R-57.5 (10.13)	R-50.8 (8.94)	0.020 (0.11)
R-66.0 (11.62)	R-68.5 (12.07)	R-58.9 (10.37)	0.017 (0.10)

Base Assembly – Foundation Wall

Foundation Insulation 1D R-Value (RSI)	L_{2Df} Btu/ft ·hr ·°F (W/m K)
R-22.5 (3.96)	0.744 (0.430)

Foundation Linear Transmittance

Fill Insulation 1D R-Value (RSI)	R_{1D} ft ² ·hr·°F / Btu (m ² K / W)	R ft ² ·hr·°F / Btu (m ² K / W)	U Btu/ft ² ·hr ·°F (W/m ² K)	L_{2Dt} Btu/ft ·hr ·°F (W/m K)	ψ Btu/ft ·hr ·°F (W/m K)
R-38.5 (6.78)	R-41.0 (7.23)	R-30.0 (5.28)	0.189 (1.07)	0.988 (0.571)	0.056 (0.032)
R-44.0 (7.75)	R-46.5 (8.19)	R-30.6 (5.38)	0.186 (1.05)	0.969 (0.560)	0.057 (0.033)
R-55.0 (9.69)	R-57.5 (10.13)	R-31.4 (5.54)	0.181 (1.03)	0.943 (0.545)	0.058 (0.034)
R-66.0 (11.62)	R-68.5 (12.07)	R-32.1 (5.65)	0.177 (1.01)	0.924 (0.534)	0.059 (0.034)

Temperature Indices

	R38.5	R44.0	R55.0	R66.0	
T_{i1}	0.89	0.89	0.89	0.89	Min T on gypsum, at studs on floor
T_{i2}	0.82	0.82	0.82	0.82	Min T on concrete floor, at edge

Temperature indices for all other scenarios can be interpolated

Detail 8.6.15

Interior Insulated Double Framed Wall 2x6 and 2x4 Wood Stud (16" o.c.) Wall Assembly with 2" Gap and R-45 Slab Insulation with Gravel Base – Slab on Grade Foundation Intersection

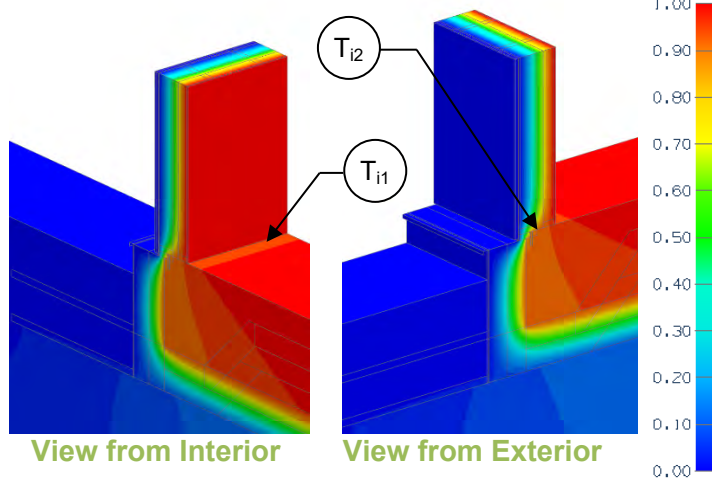

Thermal Performance Indicators

Assembly 1D (Nominal) R-Value	R_{1D}	R-2.5 (0.44 RSI) + exterior insulation for double framed wall
Transmittance / Resistance without Anomaly	U_w, R_w	"clear field" U- and R-value
Transmittance / Resistance	U, R	U and R-values for the overall assembly
Surface Temperature Index ¹	T_i	0 = exterior temperature 1 = interior temperature
Foundation Transmittance ²	L_{2Df}, L_{2Dt}	Heat loss of slab on grade per unit width of slab: f = floor t = floor + wall + foundation
Linear Transmittance	ψ	Incremental increase in transmittance per linear length of foundation

¹Assumptions and limitations for surface temperatures identified in ASHRAE 1365-RP

²For on grade transition calculation, see Appendix B introduction

Nominal (1D) vs. Assembly Performance Indicators

Base Assembly – Above Grade Wall

Fill Insulation 1D R-Value (RSI)	R_{1D} ft ² ·hr·°F / Btu (m ² K / W)	R_w ft ² ·hr·°F / Btu (m ² K / W)	U_w Btu/ft ² ·hr ·°F (W/m ² K)
R-38.5 (6.78)	R-41.0 (7.23)	R-38.0 (6.70)	0.026 (0.15)
R-44.0 (7.75)	R-46.5 (8.19)	R-42.4 (7.47)	0.024 (0.13)
R-55.0 (9.69)	R-57.5 (10.13)	R-50.8 (8.94)	0.020 (0.11)
R-66.0 (11.62)	R-68.5 (12.07)	R-58.9 (10.37)	0.017 (0.10)

Base Assembly – Foundation Wall

Foundation Insulation 1D R-Value (RSI)	L_{2Df} Btu/ft ·hr ·°F (W/m K)
R-45.0 (7.93)	0.466 (0.269)

Foundation Linear Transmittance

Fill Insulation 1D R-Value (RSI)	R_{1D} ft ² ·hr·°F / Btu (m ² K / W)	R ft ² ·hr·°F / Btu (m ² K / W)	U Btu/ft ² ·hr ·°F (W/m ² K)	L_{2Dt} Btu/ft ·hr ·°F (W/m K)	ψ Btu/ft ·hr ·°F (W/m K)
R-38.5 (6.78)	R-41.0 (7.23)	R-40.7 (7.17)	0.140 (0.79)	0.728 (0.421)	0.075 (0.043)
R-44.0 (7.75)	R-46.5 (8.19)	R-41.8 (7.35)	0.136 (0.77)	0.710 (0.410)	0.075 (0.044)
R-55.0 (9.69)	R-57.5 (10.13)	R-43.4 (7.64)	0.131 (0.74)	0.683 (0.395)	0.077 (0.044)
R-66.0 (11.62)	R-68.5 (12.07)	R-44.6 (7.86)	0.127 (0.72)	0.664 (0.384)	0.077 (0.045)

Temperature Indices

	R38.5	R44.0	R55.0	R66.0	
T_{i1}	0.91	0.91	0.91	0.91	Min T on gypsum, at studs on floor
T_{i2}	0.85	0.85	0.86	0.86	Min T on concrete floor, at edge

Temperature indices for all other scenarios can be interpolated



Detail 8.7.1

Exterior and Interior Insulated Wood Infill Wall Assembly with Wood Strapping and Continuous Insulation Supporting Fiber Cement Board and R-19 Batt Insulation in Stud Cavity – Concrete Wall and Intermediate Floor Intersection with Flashing Bypassing Exterior Insulation

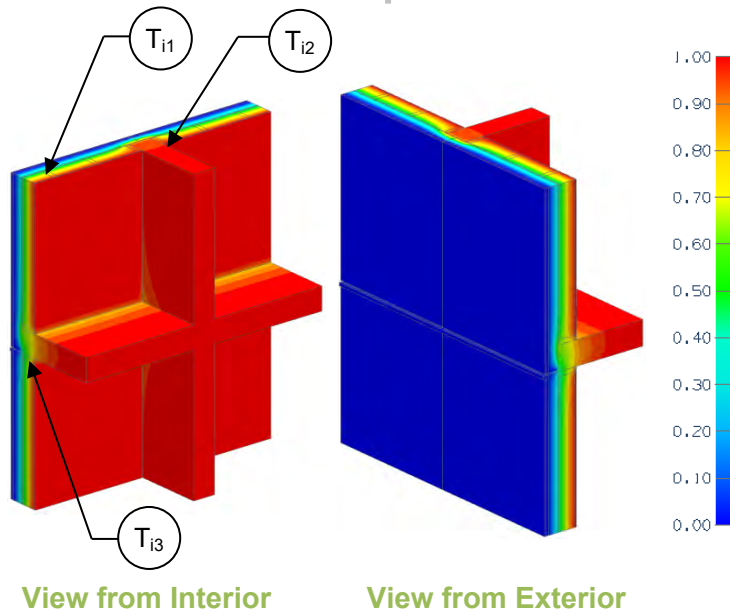

Thermal Performance Indicators

Assembly 1D (Nominal) R-Value	R_{1D}	R-21.6 (3.80 RSI) + exterior insulation
Transmittance / Resistance without Anomaly	U_o, R_o	“clear field” U- and R-value of concrete and wood infill assembly
Transmittance / Resistance	$U_s, R_s, U_i, R_t, U_t, R_t$	U and R-values for: s = wood infill wall + slab i = wood infill wall + interior wall t = combined assembly with wood infill wall + slab + interior wall
Surface Temperature Index ¹	T_i	0 = exterior temperature 1 = interior temperature
Linear Transmittance	ψ_s, ψ_i	Incremental increase in transmittance per linear length of s = slab i = interior wall
Point Transmittance	χ	Incremental increase in transmittance for inner wall and slab intersection

¹Assumptions and limitations for surface temperatures identified in ASHRAE 1365-RP

Nominal (1D) vs. Assembly Performance Indicators

Base Assembly – Wall

Wall Exterior Insulation 1D R-Value (RSI)	R_{1D} ft ² ·hr·°F / Btu (m ² K / W)	R_o ft ² ·hr·°F / Btu (m ² K / W)	U_o Btu/ft ² ·hr·°F (W/m ² K)
R-5 (0.88)	R-26.6 (4.68)	R-24.6 (4.33)	0.041 (0.23)
R-10 (1.76)	R-31.6 (5.56)	R-29.2 (5.14)	0.034 (0.19)
R-15 (2.64)	R-36.6 (6.44)	R-33.7 (5.93)	0.030 (0.17)

Slab Linear Transmittance

R_s ft ² hr °F / Btu (m ² K / W)	U_s Btu/ft ² ·hr·°F (W/m ² K)	ψ_s Btu/ft·hr·°F (W/m K)
R-12.8 (2.25)	0.078 (0.44)	0.34 (0.582)
R-14.1 (2.48)	0.071 (0.40)	0.33 (0.568)
R-15.5 (2.72)	0.065 (0.37)	0.31 (0.542)

Interior Linear Transmittance

Wall Exterior Insulation 1D R-Value (RSI)	R_i ft ² ·hr·°F / Btu (m ² K / W)	U_i Btu/ft ² ·hr·°F (W/m ² K)	ψ_i Btu/ft·hr·°F (W/m K)
R-5 (0.88)	R-17.0 (3.00)	0.059 (0.33)	0.13 (0.232)
R-10 (1.76)	R-21.4 (3.78)	0.047 (0.26)	0.09 (0.159)
R-15 (2.64)	R-26.1 (4.60)	0.038 (0.22)	0.06 (0.110)

Intersection Point Transmittance

R_t ft ² ·hr·°F / Btu (m ² K / W)	U_t Btu/ft ² ·hr·°F (W/m ² K)	χ^2 Btu/·hr·°F (W/K)
R-10.9 (1.93)	0.091 (0.52)	-0.40 (-0.209)
R-12.6 (2.22)	0.079 (0.45)	-0.34 (-0.178)
R-13.8 (2.42)	0.073 (0.41)	-0.11 (-0.059)

Temperature Indices

²Values are negative for a correction factor. See section 6 in ASHRAE 1365-RP for clarification.

	R5	R10	R15	
T_{i1}	0.25	0.33	0.38	Min T on sheathing, along studs at fasteners
T_{i2}	0.80	0.86	0.89	Max T on sheathing, along edge of interior concrete wall
T_{i3}	0.77	0.77	0.78	Min T on concrete, at wood frame wall and concrete ceiling intersection



Detail 8.7.2

Exterior Insulated Cross Laminated Timber (CLT) Wall Assembly with Wood Strapping and Continuous Rigid Insulation Supporting Fiber Cement Board – Cross Laminated Timber Floor Intersection with Flashing Bypassing Exterior Insulation

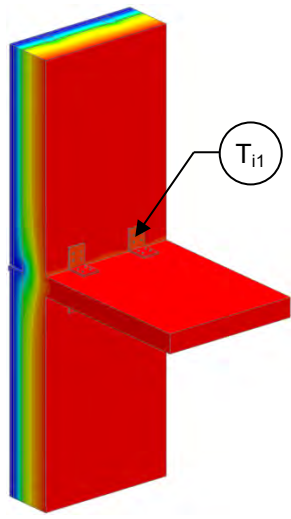

View from Interior

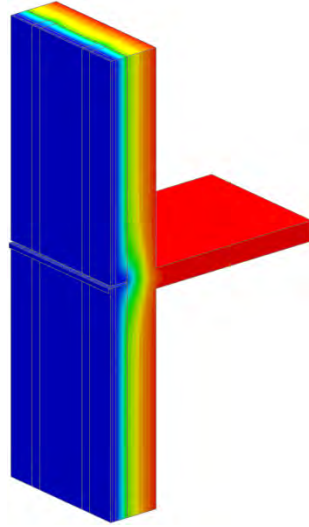

View from Exterior

Thermal Performance Indicators

Assembly 1D (Nominal) R-Value	R_{1D}	R-10.5 (1.85 RSI) + exterior insulation
Transmittance / Resistance without Anomaly	U_o, R_o	“clear wall” U- and R-value, without CLT floor slab
Transmittance / Resistance	U, R	U and R-values for the overall assembly
Surface Temperature Index ¹	T_i	0 = exterior temperature 1 = interior temperature
Linear Transmittance	ψ	Incremental increase in transmittance per linear length of CLT floor slab

¹Assumptions and limitations for surface temperatures identified in ASHRAE 1365-RP

Nominal (1D) vs. Assembly Performance Indicators

Exterior Insulation 1D R-Value (RSI)	R_{1D} ft ² ·hr·°F / Btu (m ² K / W)	R_o ft ² ·hr·°F / Btu (m ² K / W)	U_o Btu/ft ² ·hr·°F (W/m ² K)	R ft ² ·hr·°F / Btu (m ² K / W)	U Btu/ft ² ·hr·°F (W/m ² K)	ψ Btu/ft·hr·°F (W/m K)
R-15 (2.64)	R-25.5 (4.49)	R-22.9 (4.04)	0.044 (0.25)	R-21.6 (3.81)	0.046 (0.26)	0.044 (0.075)
R-20 (3.52)	R-30.5 (5.37)	R-26.8 (4.72)	0.037 (0.21)	R-24.4 (4.30)	0.041 (0.23)	0.049 (0.084)
R-25 (4.40)	R-35.5 (6.25)	R-30.5 (5.36)	0.033 (0.19)	R-26.9 (4.73)	0.037 (0.21)	0.053 (0.092)

Temperature Indices

	R15	R20	R25	
T_{i1}	0.95	0.95	0.95	Min T on bolt head around edge touching bracket

Detail 8.7.3

Exterior and Interior Insulated 2x6 Wood Stud (16" o.c.) Wall Assembly with Wood Strapping and Continuous Insulation Supporting Fiber Cement Board – One-Hour Fire Wall Intersection

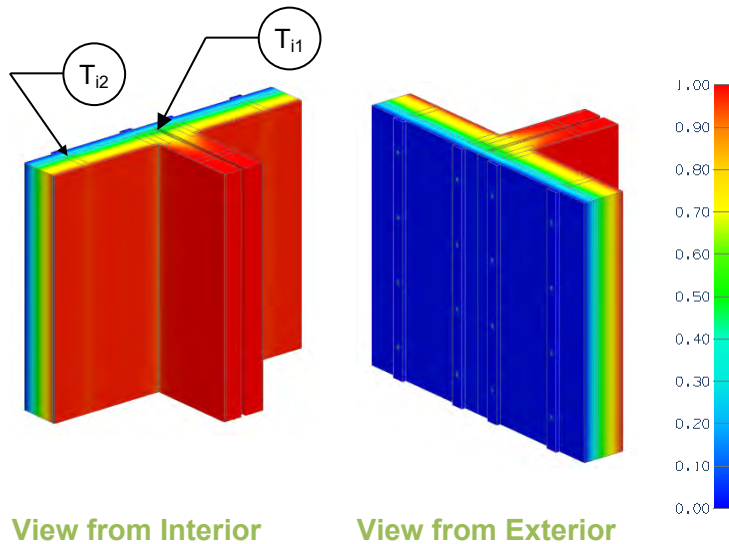

Thermal Performance Indicators

Assembly 1D (Nominal) R-Value	R_{1D}	R-21.5 (3.79 RSI) + exterior insulation
Transmittance / Resistance without Anomaly	U_o, R_o	“clear field” U- and R-value, without fire wall
Transmittance / Resistance	U, R	U- and R-values for the overall assembly
Surface Temperature Index ¹	T_i	0 = exterior temperature 1 = interior temperature
Linear Transmittance	ψ	Incremental increase in transmittance per linear length of fire wall

¹Assumptions and limitations for surface temperatures identified in ASHRAE 1365-RP

Nominal (1D) vs. Assembly Performance Indicators

Exterior Insulation 1D R-Value (RSI)	R_{1D} ft ² ·hr·°F / Btu (m ² K / W)	R_o ft ² ·hr·°F / Btu (m ² K / W)	U_o Btu/ft ² ·hr ·°F (W/m ² K)	R ft ² ·hr·°F / Btu (m ² K / W)	U Btu/ft ² ·hr ·°F (W/m ² K)	ψ Btu/ft ·hr·°F (W/m K)
R-0.0 (0.00)	R-21.5 (3.79)	R-19.7 (3.47)	0.051 (0.29)	R-18.6 (3.28)	0.054 (0.31)	0.0141 (0.0244)
R-5.0 (0.88)	R-26.5 (4.67)	R-24.6 (4.34)	0.041 (0.23)	R-23.7 (4.17)	0.042 (0.24)	0.0078 (0.0135)
R-10.0 (1.76)	R-31.5 (5.56)	R-29.2 (5.15)	0.034 (0.19)	R-28.3 (4.98)	0.035 (0.20)	0.0056 (0.0097)
R-15.0 (2.64)	R-36.5 (6.44)	R-33.6 (5.91)	0.030 (0.17)	R-32.5 (5.72)	0.031 (0.18)	0.0049 (0.0084)

Temperature Indices

	R0	R5	R10	R15	
T_{i1}	0.12	0.33	0.45	0.50	Max T on sheathing, at fire wall and exterior wall intersection
T_{i2}	0.11	0.19	0.26	0.30	Min T on sheathing, at fastener

9.0 Doors and Balconies

Detail 9.1.1	B.9.1
Interior Insulated Concrete Curb at Sliding Door Sill and Window Head – Intermediate Floor Intersection	
Detail 9.1.2	B.9.2
Non- Insulated Sliding Door Sill and Window Head – Intermediate Floor Intersection	
Detail 9.1.3	B.9.3
Interior Insulated Concrete Curb – Window-Wall and Intermediate Floor Intersection	
Detail 9.1.4	B.9.4
Exterior Insulated Concrete Curb at Sliding Door Sill and Head- Intermediate Floor Intersection	
Detail 9.1.5	B.9.5
Exterior Insulated Concrete Curb – Window-Wall and Recessed Intermediate Floor Intersection	
Detail 9.1.6	B.9.6
Window Wall System with Spandrel Panels and Sliding Door - Concrete Balcony and Curb Intersection	
Detail 9.1.7	B.9.7
Window-wall with Sliding Door and Insulated Spandrel Section – Concrete Intermediate Floor Intersection without Concrete Curb for Alternative Balcony Slab Connections	
Detail 9.1.8	B.9.8
Window Wall System with Spandrel Panels and Sliding Door - Thermally Broken Concrete Balcony and Curb Intersection	
Detail 9.1.9	B.9.9
Window Wall System with Spandrel Panels - Concrete Balcony and Bypass Intersection	
Detail 9.1.10	B.9.10
Interior Insulated 3 5/8" x 1 5/8" Steel Stud (16" o.c.) Wall Assembly - Door Sill with Exterior Slab Insulation	
Detail 9.1.11	B.9.11
Exterior and Interior Insulated 3 5/8" x 1 5/8" Steel Stud (16" o.c.) Wall Assembly - Door Sill with Exterior Slab Insulation	
Detail 9.1.12	B.9.12
Window Wall System with Spandrel Panels and Sliding Door - Schöck Isokorb K65-V8 Thermal Break at Concrete Balcony and Curb Intersection	
Detail 9.1.13	B.9.13

Window Wall System with Spandrel Panels and Sliding Door - Schöck Isokorb K10-V6 Thermal Break at Concrete Balcony and Curb Intersection	
Detail 9.1.14	B.9.14
Window Wall System with Spandrel Panels and Sliding Door - Schöck Isokorb KXT65-V8 Thermal Break at Concrete Balcony and Curb Intersection	
Detail 9.1.15	B.9.15
Window Wall System with Spandrel Panels and Sliding Door - Schöck Isokorb KXT15-V6 Thermal Break at Concrete Balcony and Curb Intersection	
Detail 9.1.16	B.9.16
Exterior Insulated 2"x6" Steel Stud (16" o.c.) Wall Assembly with FRP Vertical Brackets and Rail System Supporting Metal Cladding and Sliding Door – Intermittently Attached Balcony and Sliding Door Intersection	
Detail 9.1.17	B.9.17
Exterior and Interior Insulated 2"x6" Steel Stud (16" o.c.) Wall Assembly with FRP Vertical Brackets and Rail System Supporting Metal Cladding with R-19 Batt in Stud Cavity and Sliding Door – Intermittently Attached Balcony and Sliding Door Intersection	
Detail 9.1.18	B.9.18
Exterior Insulated 2" x 6" Steel Stud (16" o.c.) Wall Assembly with Vertical Clips (24" o.c.) Supporting Cladding and Sliding Door – Concrete Balcony and Curb Intersection	
Detail 9.1.19	B.9.19
Exterior and Interior Insulated 2" x 6" Steel Stud (16" o.c.) Wall Assembly with Vertical Clips (24" o.c.) Supporting Cladding with R-19 Batt in Stud Cavity and Sliding Door – Concrete Balcony and Curb Intersection	
Detail 9.1.20	B.9.20
Exterior Insulated 2" x 6" Steel Stud (16" o.c.) Wall Assembly with Vertical Clips (24" o.c.) Supporting Cladding and Sliding Door – Structural Thermal Break at Concrete Balcony and Curb Intersection	
Detail 9.1.21	B.9.21
Exterior and Interior Insulated 2" x 6" Steel Stud (16" o.c.) Wall Assembly with Vertical Clips (24" o.c.) Supporting Cladding with R-19 Batt in Stud Cavity and Sliding Door – Structural Thermal Break at Concrete Balcony and Curb Intersection	

Detail 9.1.1

Interior Insulated Concrete Curb at Sliding Door Sill and Window Head – Intermediate Floor Intersection

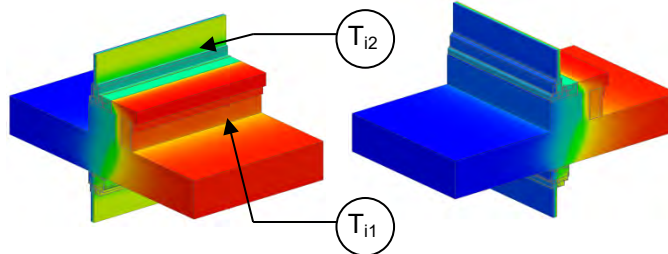

View from Interior

View from Exterior

Thermal Performance Indicators

Transmittance / Resistance ¹	U, R	U- and R-values for overall assembly
Surface Temperature Index ²	T _i	0 = exterior temperature 1 = interior temperature

¹ Projected distance from bottom of slab to top of curb

² Assumptions and limitations for surface temperatures identified in ASHRAE 1365-RP

Thermal Transmittance

Sliding Door with Curb

R	U
ft ² ·hr·°F / Btu (m ² K / W)	Btu/ft ² ·hr ·°F (W/m ² K)
R-1.6 (0.29)	0.618 (3.509)

Temperature Indices

T _{i1}	0.83	Min T on interior concrete, at gypsum, at studs
T _{i2}	0.44	Min T on glass, at gaskets



Detail 9.1.2

Non- Insulated Sliding Door Sill and Window Head – Intermediate Floor Intersection

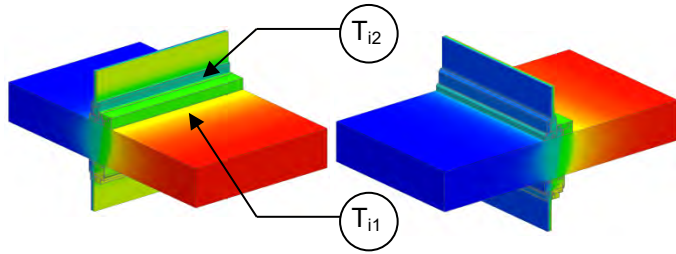

View from Interior

View from Exterior

Thermal Performance Indicators

Transmittance / Resistance ¹	U, R	U- and R-value
Surface Temperature Index ²	T _i	0 = exterior temperature 1 = interior temperature

¹ Projected distance from bottom of slab to top of curb

² Assumptions and limitations for surface temperatures identified in ASHRAE 1365-RP

Thermal Transmittance

Sliding Door without Curb

R	U
ft ² ·hr·°F / Btu (m ² K / W)	Btu/ft ² ·hr ·°F (W/m ² K)
R-1.2 (0.22)	0.807 (4.59)

Temperature Indices

T _{i1}	0.58	Min T on interior concrete, at frame
T _{i2}	0.48	Min T on glass, at gaskets

Detail 9.1.3

Interior Insulated Concrete Curb – Window-Wall and Intermediate Floor Intersection

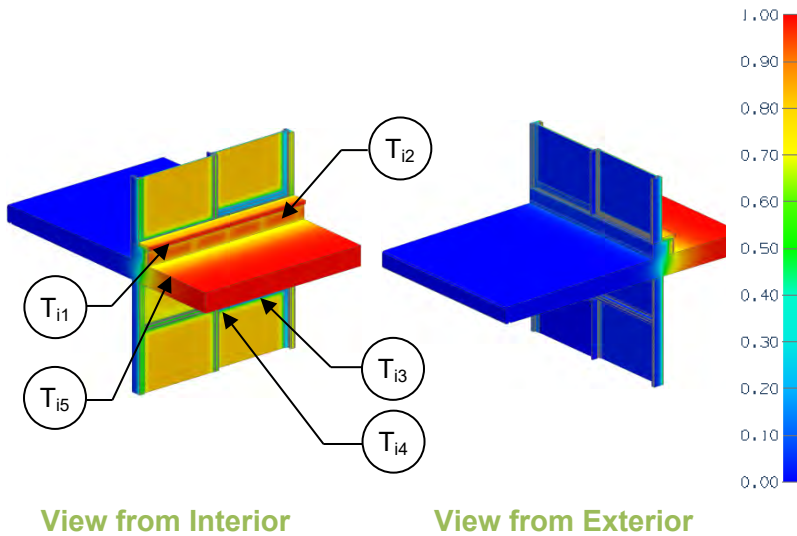

Thermal Performance Indicators

Transmittance without Anomaly	U_g	U-value for glazed sliding door, including framing
Transmittance / Resistance	U_s, R_s, U_t, R_t	U and R-values for s = balcony slab + curb only t = combined glazing + slab
Surface Temperature Index ¹	T_i	0 = exterior temperature 1 = interior temperature
Linear Transmittance	ψ	Incremental increase in transmittance per linear length of slab

¹Assumptions and limitations for surface temperatures identified in ASHRAE 1365-RP

Nominal (1D) vs. Assembly Performance Indicators

Base Assembly – Glazed Door

$U_{\text{centre of glass}}$ Btu/ft ² · hr · °F (W/m ² K)	U_g Btu/ft ² · hr · °F (W/m ² K)
0.321 (1.82)	0.486 (2.76)

Slab Linear Transmittance

Curb Insulation 1D R-Value (RSI)	R_t ft ² · hr · °F / Btu (m ² K / W)	U_t Btu/ft ² · hr · °F (W/m ² K)	ψ^2 Btu/ft · hr · °F (W/m K)
R-10 (1.76)	R-1.8 (0.32)	0.545 (3.09)	0.974 (1.686)

Balcony Only

R_s ft ² · hr · °F / Btu (m ² K / W)	U_s Btu/ft ² · hr · °F (W/m ² K)
R-1.2 (0.21)	0.832 (4.72)

²Transmittance not based on an opaque wall clear field value. See Part 1 Dealing with Floor to Floor Glazing.

Temperature Indices

T_{i1}	0.50	Min T on concrete, between studs by wood block by fixed window
T_{i2}	0.67	Max T on concrete, between studs by sliding door
T_{i3}	0.16	Min T on window frame, middle of track at top of door (below slab)
T_{i4}	0.15	Min T on window glass, top middle corner of door glazing (below slab)
T_{i5}	0.50	Min T on slab, along spandrel head, on fixed window side

Detail 9.1.4

Exterior Insulated Concrete Curb at Sliding Door Sill and Head-Intermediate Floor Intersection

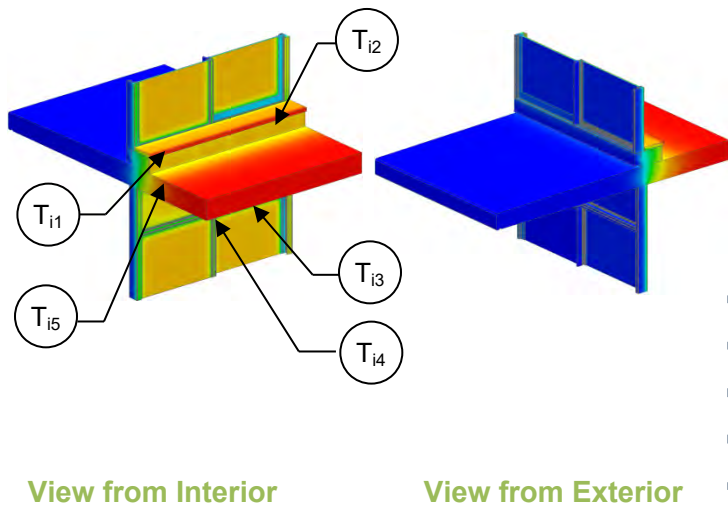

Thermal Performance Indicators

Transmittance without Anomaly	U_g	U-value for glazed sliding door, including framing
Transmittance / Resistance	U_s, R_s, U_t, R_t	U and R-values for s = balcony slab + curb only t = combined glazing + slab
Surface Temperature Index ¹	T_i	0 = exterior temperature 1 = interior temperature
Linear Transmittance	ψ	Incremental increase in transmittance per linear length of slab

¹Assumptions and limitations for surface temperatures identified in ASHRAE 1365-RP

Nominal (1D) vs. Assembly Performance Indicators

Base Assembly – Glazed Door

$U_{\text{centre of glass}}$ Btu/ft ² ·hr ·°F (W/m ² K)	U_g Btu/ft ² ·hr ·°F (W/m ² K)
0.321 (1.82)	0.486 (2.76)

Slab Linear Transmittance

Curb Insulation 1D R-Value (RSI)	R_t ft ² ·hr·°F / Btu (m ² K / W)	U_t Btu/ft ² ·hr ·°F (W/m ² K)	ψ^2 Btu/ft ² ·hr ·°F (W/m K)
R-10 (1.76)	R-1.8 (0.19)	0.558 (3.17)	1.066 (1.844)
R-15 (2.64)	R-1.8 (0.19)	0.558 (3.17)	1.064 (1.842)

Balcony Only

R_s ft ² ·hr·°F / Btu (m ² K / W)	U_s Btu/ft ² ·hr ·°F (W/m ² K)
R-1.1 (0.19)	0.910 (5.17)
R-1.1 (0.19)	0.909 (5.16)

²Transmittance not based on an opaque wall clear field value. See Part 1 Dealing with Floor to Floor Glazing.

Temperature Indices

	R10	R15	
T_{i1}	0.49	0.49	Min T on concrete, between studs by wood block by fixed window
T_{i2}	0.57	0.57	Max T on concrete, between studs by sliding door
T_{i3}	0.16	0.16	Min T on window frame, middle of track at top of door (below slab)
T_{i4}	0.15	0.15	Min T on window glass, top middle corner of door glazing (below slab)
T_{i5}	0.50	0.50	Min T on slab, along spandrel head, on fixed window side



Detail 9.1.5

Exterior Insulated Concrete Curb – Window-Wall and Recessed Intermediate Floor Intersection

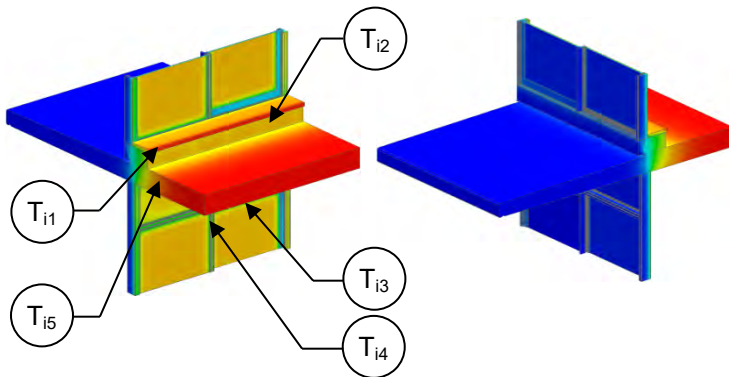

View from Interior

View from Exterior

Thermal Performance Indicators

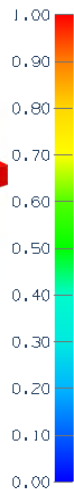

Transmittance without Anomaly	U_g	U-value for glazed sliding door, including framing
Transmittance / Resistance	U_s, R_s, U_t, R_t	U and R-values for s = balcony slab + curb only t = combined glazing + slab
Surface Temperature Index ¹	T_i	0 = exterior temperature 1 = interior temperature
Linear Transmittance	ψ	Incremental increase in transmittance per linear length of slab

¹Assumptions and limitations for surface temperatures identified in ASHRAE 1365-RP

Nominal (1D) vs. Assembly Performance Indicators

Base Assembly – Glazed Door

$U_{\text{centre of glass}}$ Btu/ft ² · hr · °F (W/m ² K)	U_g Btu/ft ² · hr · °F (W/m ² K)
0.321 (1.82)	0.486 (2.76)

Slab Linear Transmittance

Curb Insulation 1D R-Value (RSI)	R ft ² · hr · °F / Btu (m ² K / W)	U Btu/ft ² · hr · °F (W/m ² K)	ψ^2 Btu/ft · hr · °F (W/m K)
R-10 (1.76)	R-1.8 (0.32)	0.556 (3.16)	1.053 (1.822)
R-15 (2.64)	R-1.8 (0.32)	0.556 (3.15)	1.050 (1.817)

Balcony Only

R_s ft ² · hr · °F / Btu (m ² K / W)	U_s Btu/ft ² · hr · °F (W/m ² K)
R-1.1 (0.20)	0.900 (5.11)
R-1.1 (0.20)	0.897 (5.09)

²Transmittance not based on an opaque wall clear field value. See Part 1 Dealing with Floor to Floor Glazing

Temperature Indices

	R10	R15	
T_{i1}	0.50	0.50	Min T on concrete, between studs by wood block by fixed window
T_{i2}	0.58	0.58	Max T on concrete, between studs by sliding door
T_{i3}	0.16	0.16	Min T on window frame, middle of track at top of door (below slab)
T_{i4}	0.15	0.15	Min T on window glass, top middle corner of door glazing (below slab)
T_{i5}	0.50	0.50	Min T on slab, along spandrel head, on fixed window side

Detail 9.1.6

Window Wall System with Spandrel Panels and Sliding Door - Concrete Balcony and Curb Intersection

Thermal Performance Indicators

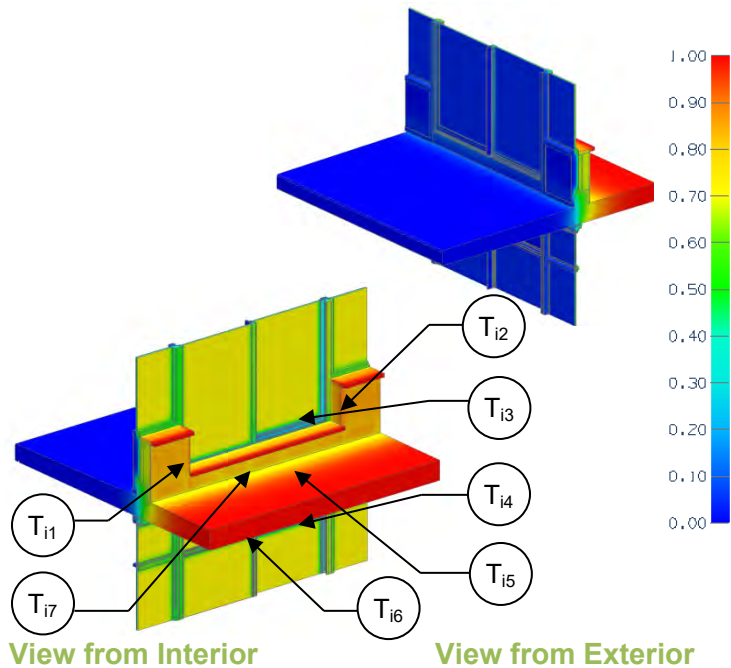

Assembly 1D (Nominal) R-Value	R_{1D}	R-3.2 (0.55 RSI) + backpan insulation
Transmittance without Anomaly	U_g	U-value for glazed sliding door, including framing
Transmittance / Resistance	U_w , R_w , U_s , R_s , U_t , R_t	U and R-values for w = spandrel wall s = balcony slab + curb only t = combined glazing + spandrel + slab
Surface Temperature Index ¹	T_i	0 = exterior temperature 1 = interior temperature
Linear Transmittance	ψ_w , ψ_s	Incremental increase in transmittance per linear length of w = slab under spandrel s = slab under door

¹Assumptions and limitations for surface temperatures identified in ASHRAE 1365-RP

Nominal (1D) vs. Assembly Performance Indicators

Base Assembly – Spandrel Section without Slab

Backpan Insulation 1D R-Value (RSI)	R_{1D} ft ² ·hr·°F / Btu (m ² K / W)	R_w ft ² ·hr·°F / Btu (m ² K / W)	U_w Btu/ft ² ·hr ·°F (W/m ² K)
R-8.4 (1.48)	R-11.6 (2.03)	R-6.3 (1.11)	0.158 (0.90)
R-12.6 (2.25)	R-15.7 (2.77)	R-7.1 (1.26)	0.140 (0.80)

Base Assembly – Glazed Door

$U_{\text{centre of glass}}$ Btu/ft ² ·hr ·°F (W/m ² K)	U_g Btu/ft ² ·hr ·°F (W/m ² K)
0.321 (1.82)	0.486 (2.76)

Balcony Linear Transmittance

Backpan Insulation 1D R-Value (RSI)	R_t ft ² ·hr·°F / Btu (m ² K / W)	U_t Btu/ft ² ·hr ·°F (W/m ² K)	ψ_s^2 Btu/ft ·hr·°F (W/m K)
R-8.4 (1.48)	R-1.9 (0.34)	0.519 (2.95)	0.645 (1.116)
R-12.6 (2.25)	R-1.9 (0.34)	0.519 (2.95)	0.645 (1.116)

Balcony Only

R_s ft ² ·hr·°F / Btu (m ² K / W)	U_s Btu/ft ² ·hr ·°F (W/m ² K)
R-1.8 (0.32)	0.551 (3.13)
R-1.8 (0.32)	0.551 (3.13)

²Transmittance not based on an opaque wall clear field value. See Part 1 Dealing with Floor to Floor Glazing.

Temperature Indices

	R8.4	R12.6	
T_{i1}	0.47	0.53	Min T on backpan, along edge of backpan
T_{i2}	0.65	0.66	Max T on backpan, at centre of backpan
T_{i3}	0.24	0.24	Min T on upper frame, along sill of sliding door frame
T_{i4}	0.15	0.15	Min T on lower frame, along head of sliding door base frame
T_{i5}	0.21	0.21	Min T on upper glazing, at bottom corner of sliding door glazing near fixed frame
T_{i6}	0.20	0.20	Min T on lower glazing, at corner of sliding door frame near fixed frame
T_{i7}	0.52	0.52	Min T on slab, along head of lower sliding door

Detail 9.1.7

Window-wall with Sliding Door and Insulated Spandrel Section – Concrete Intermediate Floor Intersection without Concrete Curb for Alternative Balcony Slab Connections

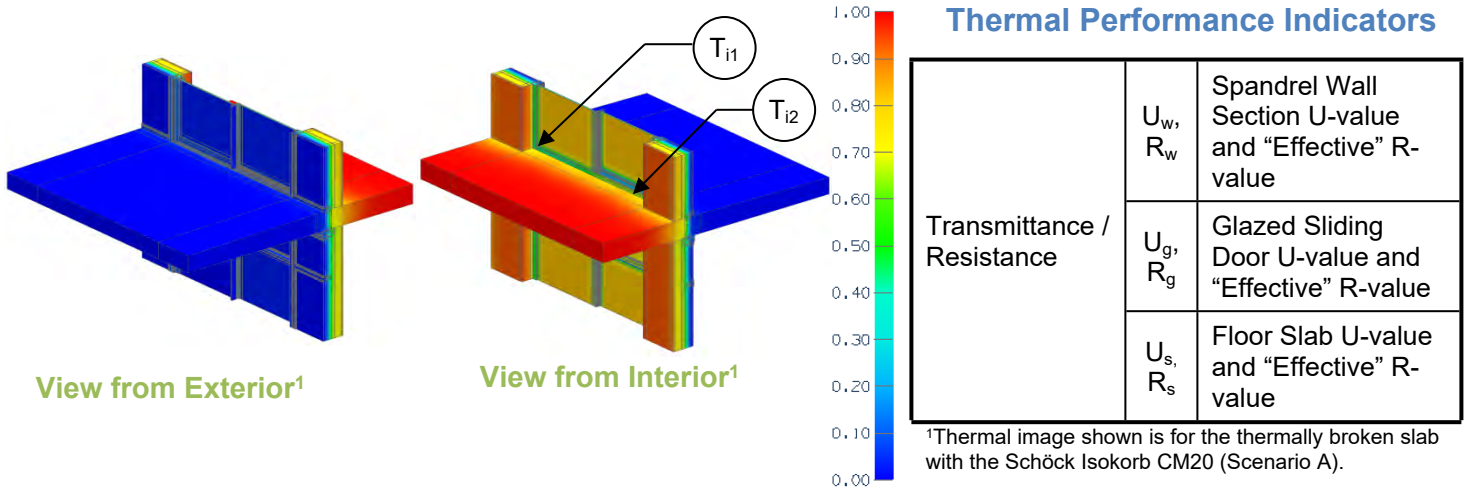

Scenarios

Scenario	Description
A	Thermally broken slab with 3” (80 mm) thick Schöck Isokorb CM20
B	Thermally Broken Slab with 1.5” (40 mm) Intermittent Slab Insulation (880mm insulation @1380)
C	Continuous Slab

Nominal (1D) vs. Assembly Performance Indicators

Scenario	U_w Btu/ft ² · hr · °F (W/m ² K)	R_w ft ² · hr · °F / Btu (m ² K / W)	U_g Btu/ft ² · hr · °F (W/m ² K)	R_g ft ² · hr · °F / Btu (m ² K / W)	U_s Btu/ft ² · hr · °F (W/m ² K)	R_s ft ² · hr · °F / Btu (m ² K / W)
A	0.140 (0.80)	R-7.1 (1.25)	0.476 (2.70)	R-2.1 (0.37)	0.213 (1.21)	R-4.7 (0.83)
B	0.140 (0.80)	R-7.1 (1.25)	0.476 (2.70)	R-2.1 (0.37)	0.680 (3.86)	R-1.5 (0.26)
C	0.140 (0.80)	R-7.1 (1.25)	0.476 (2.70)	R-2.1 (0.37)	0.859 (4.88)	R-1.2 (0.20)

Temperature Indices

	A	B	C	
T_{i1}	0.64	0.50	0.45	Min T on concrete floor, at bottom corner of door
T_{i2}	0.18	0.18	0.18	Min T on sliding door frame

Detail 9.1.8

Window Wall System with Spandrel Panels and Sliding Door - Thermally Broken Concrete Balcony and Curb Intersection

Thermal Performance Indicators

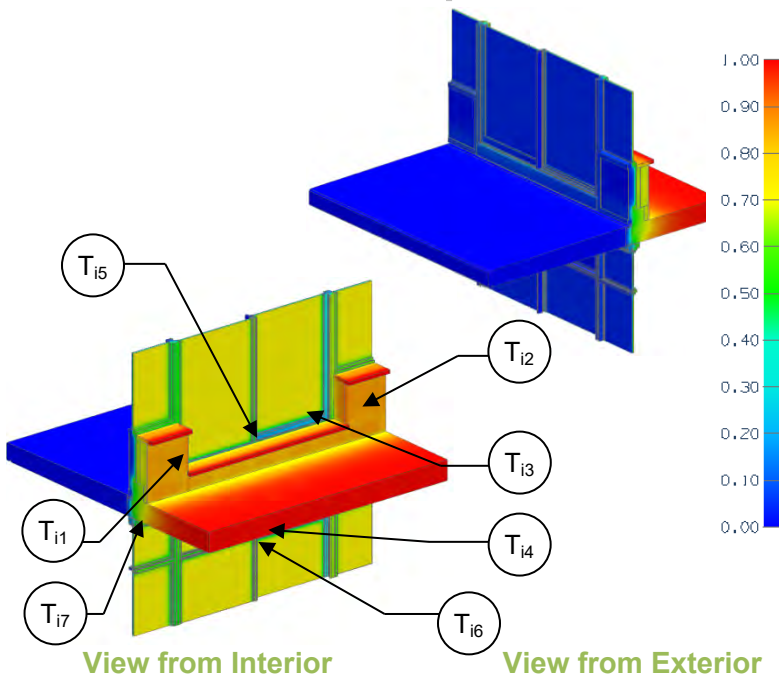

Assembly 1D (Nominal) R-Value	R_{1D}	R-3.2 (0.55 RSI) + backpan insulation
Transmittance without Anomaly	U_g	U-value for glazed sliding door, including framing
Transmittance / Resistance	$U_w, R_w, U_s, R_s, U_t, R_t$	U and R-values for w = spandrel wall s = balcony slab + curb only t = combined glazing + spandrel + slab
Surface Temperature Index ¹	T_i	0 = exterior temperature 1 = interior temperature
Linear Transmittance	Ψ_w, Ψ_s	Incremental increase in transmittance per linear length of w = slab under spandrel s = slab under door

¹Assumptions and limitations for surface temperatures identified in ASHRAE 1365-RP

Nominal (1D) vs. Assembly Performance Indicators

Base Assembly – Spandrel Section without Slab

Backpan Insulation 1D R-Value (RSI)	R_{1D} ft ² ·hr·°F / Btu (m ² K / W)	R_w ft ² ·hr·°F / Btu (m ² K / W)	U_w Btu/ft ² ·hr ·°F (W/m ² K)
R-8.4 (1.48)	R-11.6 (2.03)	R-6.3 (1.11)	0.158 (0.90)
R-12.6 (2.25)	R-15.7 (2.77)	R-7.1 (1.26)	0.140 (0.80)

Base Assembly – Glazed Door

$U_{\text{centre of glass}}$ Btu/ft ² ·hr ·°F (W/m ² K)	U_g Btu/ft ² ·hr ·°F (W/m ² K)
0.321 (1.82)	0.486 (2.76)

Balcony Linear Transmittance

Backpan Insulation 1D R-Value (RSI)	R_t ft ² ·hr·°F / Btu (m ² K / W)	U_t Btu/ft ² ·hr ·°F (W/m ² K)	Ψ_s^2 Btu/ft ·hr·°F (W/m K)
R-8.4 (1.48)	R-2.0 (0.35)	0.503 (2.86)	0.492 (0.852)
R-12.6 (2.25)	R-2.0 (0.35)	0.503 (2.85)	0.494 (0.856)

Balcony Only

R_s ft ² ·hr·°F / Btu (m ² K / W)	U_s Btu/ft ² ·hr ·°F (W/m ² K)
R-2.4 (0.42)	0.421 (2.39)
R-2.4 (0.42)	0.422 (2.40)

²Transmittance not based on an opaque wall clear field value. See Part 1 Dealing with Floor to Floor Glazing.

Temperature Indices

	R8.4	R12.6	
T_{i1}	0.50	0.50	Min T on backpan, along edge of backpan
T_{i2}	0.64	0.69	Max T on backpan, at centre of backpan
T_{i3}	0.24	0.24	Min T on upper frame, along sill of sliding door frame
T_{i4}	0.15	0.15	Min T on lower frame, along head of sliding door base frame
T_{i5}	0.20	0.20	Min T on upper glazing, at bottom corner of sliding door near fixed frame
T_{i6}	0.20	0.20	Min T on lower glazing, at corner of sliding door frame near fixed frame
T_{i7}	0.60	0.60	Min T on slab, along head of lower sliding door

Detail 9.1.9

Window Wall System with Spandrel Panels - Concrete Balcony and Bypass Intersection

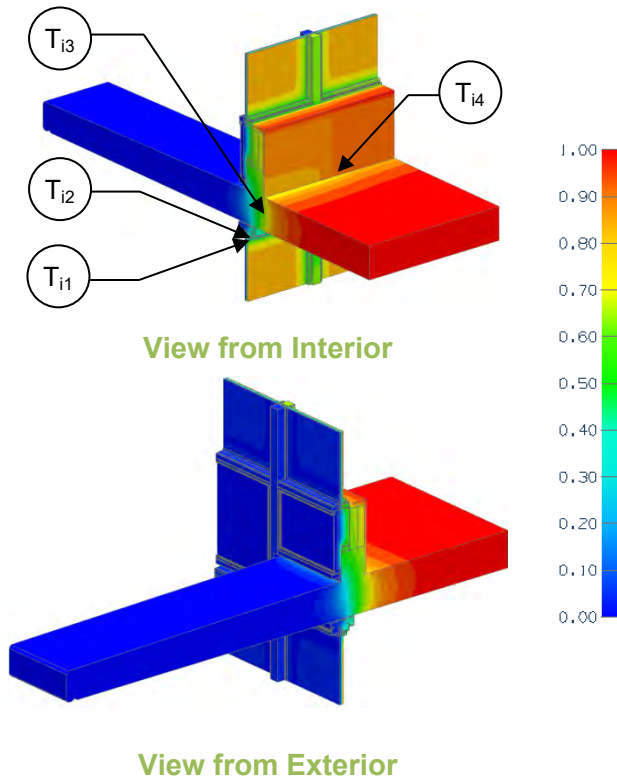

Thermal Performance Indicators

Assembly 1D (Nominal) R-Value	R_{1D}	R-3.2 (0.55 RSI) + backpan insulation
Transmittance / Resistance without Anomaly	U_o, R_o	“clear wall” U- and R-value spandrel section of window wall without slab
Transmittance / Resistance	$U_s, R_s, U_i, R_i, U_t, R_t$	U and R values for s = window wall spandrel + bypass i = window wall spandrel + balcony t = combined window wall spandrel + bypass + balcony + intersection
Surface Temperature Index ¹	T_i	0 = exterior temperature 1 = interior temperature
Linear Transmittance	ψ_s, ψ_i	Incremental increase in transmittance per linear length of s = bypass i = balcony
Point Transmittance	χ	Incremental increase in transmittance for inner wall and slab intersection

¹Assumptions and limitations for surface temperatures identified in ASHRAE 1365-RP

Nominal (1D) vs. Assembly Performance Indicators

Base Assembly – Spandrel Section without Slab

Backpan Insulation 1D R-Value (RSI)	R_{1D} ft ² ·hr·°F / Btu (m ² K / W)	R_o ft ² ·hr·°F / Btu (m ² K / W)	U_o Btu/ft ² ·hr ·°F (W/m ² K)
R-8.4 (1.48)	R-11.6 (2.03)	R-6.3 (1.11)	0.158 (0.90)
R-12.6 (2.25)	R-15.7 (2.77)	R-7.1 (1.26)	0.140 (0.80)

Bypass Linear Transmittance

R_s ft ² ·hr·°F / Btu (m ² K / W)	U_s Btu/ft ² ·hr ·°F (W/m ² K)	ψ_s Btu/ft ·hr·°F (W/m K)
R-3.6 (0.64)	0.275 (1.56)	0.350 (0.606)
R-3.8 (0.68)	0.260 (1.48)	0.359 (0.622)

Balcony Linear Transmittance

Backpan Insulation 1D R-Value (RSI)	R_i ft ² ·hr·°F / Btu (m ² K / W)	U_i Btu/ft ² ·hr ·°F (W/m ² K)	ψ_i Btu/ft ·hr·°F (W/m K)
R-8.4 (1.48)	R-2.7 (0.48)	0.368 (2.09)	0.629 (1.09)
R-12.6 (2.25)	R-2.8 (0.49)	0.357 (2.03)	0.651 (1.13)

Intersection Point Transmittance

R_t ft ² ·hr·°F / Btu (m ² K / W)	U_t Btu/ft ² ·hr ·°F (W/m ² K)	χ Btu/hr·°F (W/K)
R-3.1 (0.54)	0.326 (1.85)	0.086 (0.046)
R-3.2 (0.56)	0.313 (1.78)	0.089 (0.047)

Temperature Indices

	R6.4	R12.8	
T_{i1}	0.44	0.44	Min T on glazing, lower glazing along frame header on balcony side away from intersection
T_{i2}	0.41	0.41	Min T on frame, lower frame edge along slab on balcony side away from intersection
T_{i3}	0.47	0.47	Min T on slab, along lower frame edge on balcony side away from intersection
T_{i4}	0.55	0.57	Min T on backpan, on bottom corner on non-balcony side at intersection

Detail 9.1.10

Interior Insulated 3 5/8" x 1 5/8" Steel Stud (16" o.c.) Wall Assembly - Door Sill with Exterior Slab Insulation

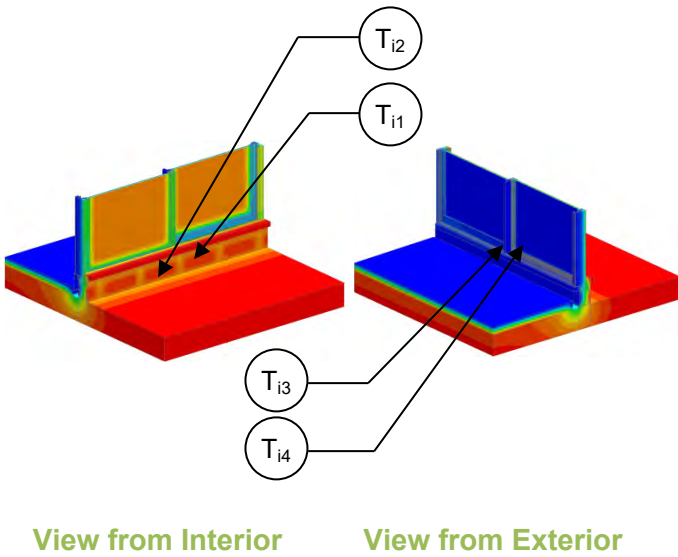

Thermal Performance Indicators

Assembly 1D (Nominal) R-Value	R_{1D}	R-1.9 (0.33 RSI) + exterior deck insulation
Transmittance / Resistance without Anomaly	U_r , R_r , U_g	"clear field" U- and R-values for two base assemblies: r = roof deck g = glazed sliding door
Transmittance / Resistance	U, R	U- and R-values for overall assembly
Surface Temperature Index ¹	T_i	0 = exterior temperature 1 = interior temperature
Linear Transmittance	ψ	Incremental increase in transmittance per linear length of door sill

¹Assumptions and limitations for surface temperatures identified in ASHRAE 1365-RP

Nominal (1D) vs. Assembly Performance Indicators

Base Assembly – Roof Deck

Slab Exterior Insulation 1D R-Value (RSI)	R_{1D} ft ² ·hr·°F / Btu (m ² K / W)	R_r ft ² ·hr·°F / Btu (m ² K / W)	U_r Btu/ft ² ·hr ·°F (W/m ² K)
R-20 (3.52)	R-21.9 (3.86)	R-21.9 (3.86)	0.046 (0.26)

Base Assembly – Glazed Door

$U_{\text{center of glazing}}$ Btu/ft ² ·hr ·°F (W/m ² K)	U_g Btu/ft ² ·hr ·°F (W/m ² K)
0.321 (1.82)	0.489 (2.78)

Door Sill Linear Transmittance

R ft ² ·hr·°F / Btu (m ² K / W)	U Btu/ft ² ·hr ·°F (W/m ² K)	ψ Btu/ft ·hr ·°F (W/m K)
R-3.0 (0.54)	0.329 (1.87)	0.395 (0.684)

Temperature Indices

Index	Value	Description
T_{i1}	0.06	Min T on sheathing between studs, mid height
T_{i2}	0.55	Max T on sheathing along slab
T_{i3}	0.22	Min T on window frame, at bottom middle corner of door track
T_{i4}	0.20	Min T on window glass, bottom middle corner of door

Detail 9.1.11

Exterior and Interior Insulated 3 5/8" x 1 5/8" Steel Stud (16" o.c.) Wall Assembly - Door Sill with Exterior Slab Insulation

Thermal Performance Indicators

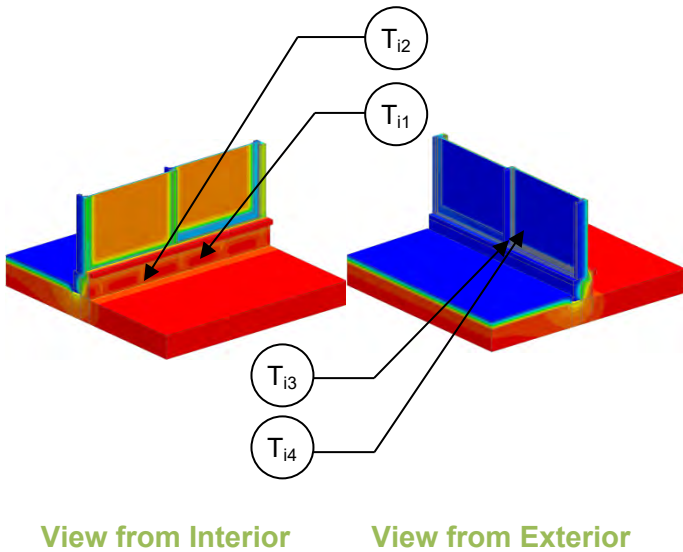

Assembly 1D (Nominal) R-Value	R_{1D}	R-1.9 (0.33 RSI) + exterior deck insulation
Transmittance / Resistance without Anomaly	U_r, R_r, U_g	"clear field" U- and R-values for: r = roof deck g = glazed sliding door
Transmittance / Resistance	U, R	U- and R-values for overall assembly
Surface Temperature Index ¹	T_i	0 = exterior temperature 1 = interior temperature
Linear Transmittance	ψ	Incremental increase in transmittance per linear length of door sill

¹Assumptions and limitations for surface temperatures identified in ASHRAE 1365-RP

Nominal (1D) vs. Assembly Performance Indicators

Base Assembly – Roof Deck

Slab Exterior Insulation 1D R-Value (RSI)	R_{1Dr} ft ² ·hr·°F / Btu (m ² K / W)	R_r ft ² ·hr·°F / Btu (m ² K / W)	U_r Btu/ft ² ·hr ·°F (W/m ² K)
R-20 (3.52)	R-21.9 (3.86)	R-21.9 (3.86)	0.046 (0.26)

Base Assembly – Door

$U_{\text{center of glazing}}$ Btu/ft ² ·hr ·°F (W/m ² K)	U_g Btu/ft ² ·hr ·°F (W/m ² K)
0.321 (1.82)	0.489 (2.78)

Door Sill Linear Transmittance

Sill Exterior Insulation 1D R-Value (RSI)	R ft ² ·hr·°F / Btu (m ² K / W)	U Btu/ft ² ·hr ·°F (W/m ² K)	ψ Btu/ft ·hr·°F (W/m K)
R-10 (1.76)	R-3.6 (0.63)	0.279 (1.58)	0.104 (0.180)
R-15 (2.64)	R-3.6 (0.63)	0.278 (1.58)	0.097 (0.169)

Temperature Indices

	R10	R15	
T_{i1}	0.47	0.49	Min T on sheathing between studs, mid height
T_{i2}	0.75	0.75	Max T on sheathing at studs
T_{i3}	0.23	0.23	Min T on window frame, at bottom middle corner of door track
T_{i4}	0.20	0.20	Min T on window glass, bottom middle corner of door

Detail 9.1.12

Window Wall System with Spandrel Panels and Sliding Door - Schöck Isokorb K65-V8 Thermal Break at Concrete Balcony and Curb Intersection

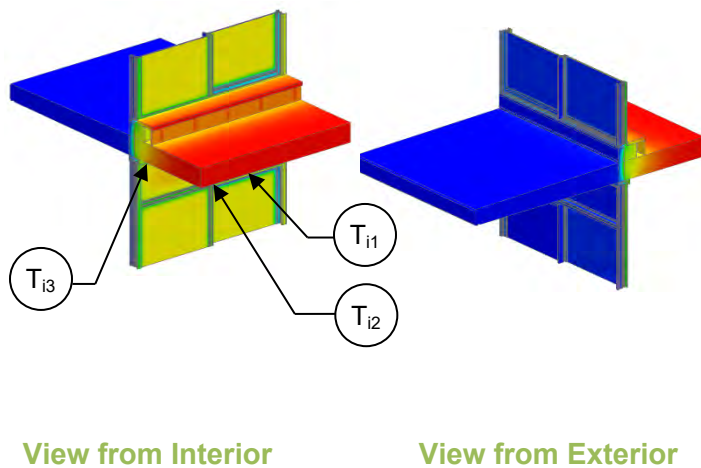

Thermal Performance Indicators

Transmittance without Anomaly	U_g	U-value for glazed sliding door, including framing
Transmittance / Resistance	U_s , R_s , U_t , R_t	U and R-values for s = balcony slab + curb t = combined glazing + slab
Surface Temperature Index ¹	T_i	0 = exterior temperature 1 = interior temperature
Linear Transmittance	ψ	Incremental increase in transmittance per linear length of slab

¹Assumptions and limitations for surface temperatures identified in ASHRAE 1365-RP

Scenarios

Scenario	Description
A	Window wall thermal break located at concrete slab, un-insulated glazing frame
B	Window wall thermal break located at Isokorb module, insulated glazing frame

Assembly Performance Indicators

Base Assembly – Glazed Door

Scenario	$U_{\text{centre of glass}}$ Btu/ft ² · hr · °F (W/m ² K)	U_g Btu/ft ² · hr · °F (W/m ² K)
A	0.321 (1.82)	0.532 (3.02)
B	0.321 (1.82)	0.502 (2.85)

Slab Linear Transmittance

Scenario	R_t ft ² · hr · °F / Btu (m ² K / W)	U_t Btu/ft ² · hr · °F (W/m ² K)	ψ^2 Btu/ft · hr · °F (W/m K)
A	R-2.0 (0.35)	0.502 (2.85)	0.426 (0.738)
B	R-2.2 (0.38)	0.465 (2.64)	0.343 (0.594)

Balcony Only

	R_s ft ² · hr · °F / Btu (m ² K / W)	U_s Btu/ft ² · hr · °F (W/m ² K)
	R-2.8 (0.50)	0.355 (2.02)
	R-3.5 (0.62)	0.286 (1.62)

²Transmittance not based on an opaque wall clear field value. See Part 1 Dealing with Floor to Floor Glazing.

Temperature Indices

	A	B	
T_{i1}	0.19	0.19	Min T on window frame, middle of track at top of door (below slab)
T_{i2}	0.51	0.51	Min T on window glass, top middle corner of door glazing (below slab)
T_{i3}	0.67	0.78	Min T on slab, along deflection header, on fixed window side

Detail 9.1.13

Window Wall System with Spandrel Panels and Sliding Door - Schöck Isokorb K10-V6 Thermal Break at Concrete Balcony and Curb Intersection

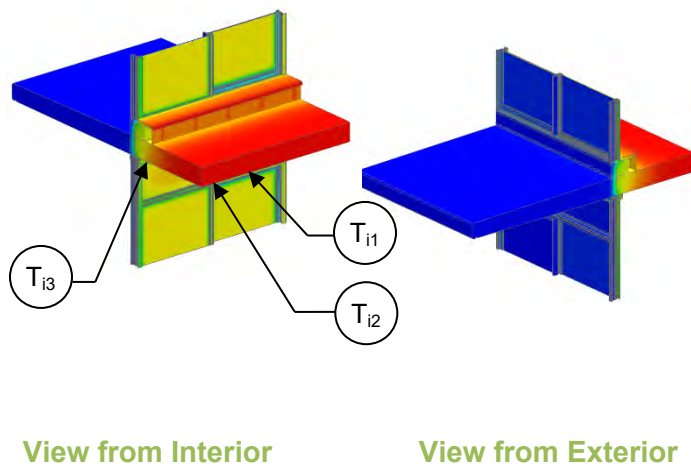

Thermal Performance Indicators

Transmittance without Anomaly	U_g	U-value for glazed sliding door, including framing
Transmittance / Resistance	U_s, R_s, U_t, R_t	U and R-values for s = balcony slab + curb t = combined glazing + slab
Surface Temperature Index ¹	T_i	0 = exterior temperature 1 = interior temperature
Linear Transmittance	ψ	Incremental increase in transmittance per linear length of slab

¹Assumptions and limitations for surface temperatures identified in ASHRAE 1365-RP

Scenarios

Scenario	Description
A	Window wall thermal break located at concrete slab, un-insulated glazing frame
B	Window wall thermal break located at Isokorb module, insulated glazing frame

Assembly Performance Indicators

Base Assembly – Glazed Door

Scenario	$U_{\text{centre of glass}}$ Btu/ft ² · hr · °F (W/m ² K)	U_g Btu/ft ² · hr · °F (W/m ² K)
A	0.321 (1.82)	0.532 (3.02)
B	0.321 (1.82)	0.502 (2.85)

Slab Linear Transmittance

Scenario	R_t ft ² · hr · °F / Btu (m ² K / W)	U_t Btu/ft ² · hr · °F (W/m ² K)	ψ^2 Btu/ft · hr · °F (W/m K)
A	R-2.0 (0.36)	0.495 (2.81)	0.379 (0.656)
B	R-2.2 (0.39)	0.456 (2.59)	0.283 (0.490)

Balcony Only

	R_s ft ² · hr · °F / Btu (m ² K / W)	U_s Btu/ft ² · hr · °F (W/m ² K)
	R-3.2 (0.56)	0.316 (1.79)
	R-4.2 (0.75)	0.236 (1.34)

²Transmittance not based on an opaque wall clear field value. See Part 1 Dealing with Floor to Floor Glazing.

Temperature Indices

	A	B	
T_{i1}	0.19	0.19	Min T on window frame, middle of track at top of door (below slab)
T_{i2}	0.51	0.51	Min T on window glass, top middle corner of door glazing (below slab)
T_{i3}	0.68	0.80	Min T on slab, along deflection header, on fixed window side

Detail 9.1.14

Window Wall System with Spandrel Panels and Sliding Door - Schöck Isokorb KXT65-V8 Thermal Break at Concrete Balcony and Curb Intersection

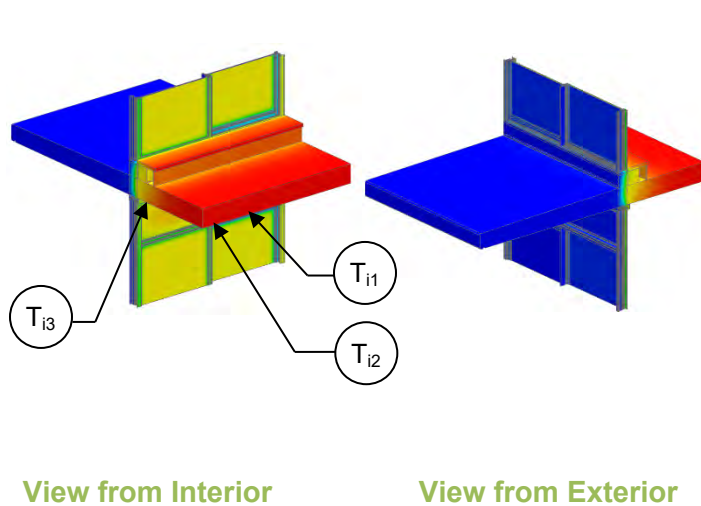

Thermal Performance Indicators

Transmittance without Anomaly	U_g	U-value for glazed sliding door, including framing
Transmittance / Resistance	U_s , R_s , U_t , R_t	U and R-values for s = balcony slab + curb t = combined glazing + slab
Surface Temperature Index ¹	T_i	0 = exterior temperature 1 = interior temperature
Linear Transmittance	ψ	Incremental increase in transmittance per linear length of slab

¹Assumptions and limitations for surface temperatures identified in ASHRAE 1365-RP

Scenarios

Scenario	Description
A	Window wall thermal break located at concrete slab, un-insulated glazing frame
B	Window wall thermal break located at Isokorb module, insulated glazing frame

Assembly Performance Indicators

Base Assembly – Glazed Door

Scenario	$U_{\text{centre of glass}}$ Btu/ft ² · hr · °F (W/m ² K)	U_g Btu/ft ² · hr · °F (W/m ² K)
A	0.321 (1.82)	0.532 (3.02)
B	0.321 (1.82)	0.502 (2.85)

Slab Linear Transmittance

Scenario	R_t ft ² · hr · °F / Btu (m ² K / W)	U_t Btu/ft ² · hr · °F (W/m ² K)	ψ^2 Btu/ft · hr · °F (W/m K)
A	R-2.1 (0.36)	0.485 (2.75)	0.306 (0.530)
B	R-2.2 (0.39)	0.456 (2.59)	0.283 (0.490)

Balcony Only

R_s ft ² · hr · °F / Btu (m ² K / W)	U_s Btu/ft ² · hr · °F (W/m ² K)
R-3.9 (0.69)	0.255 (1.45)
R-4.2 (0.75)	0.236 (1.34)

²Transmittance not based on an opaque wall clear field value. See Part 1 Dealing with Floor to Floor Glazing.

Temperature Indices

	A	B	
T_{i1}	0.19	0.19	Min T on window frame, middle of track at top of door (below slab)
T_{i2}	0.51	0.51	Min T on window glass, top middle corner of door glazing (below slab)
T_{i3}	0.71	0.79	Min T on slab, along deflection header, on fixed window side

Detail 9.1.15

Window Wall System with Spandrel Panels and Sliding Door - Schöck Isokorb KXT15-V6 Thermal Break at Concrete Balcony and Curb Intersection

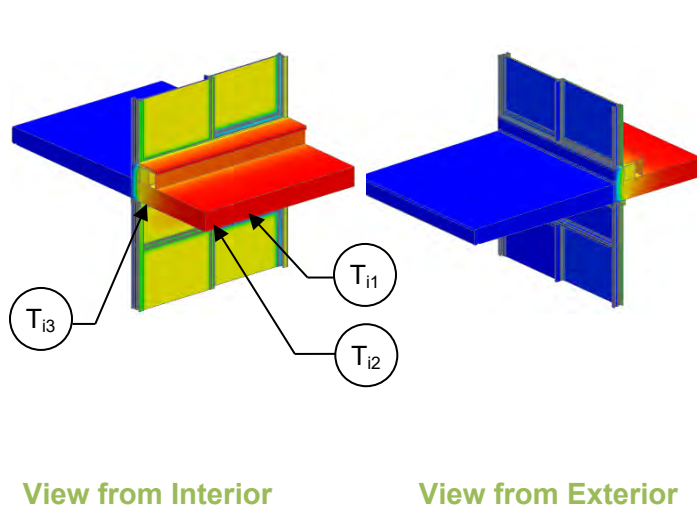

Thermal Performance Indicators

Transmittance without Anomaly	U_g	U-value for glazed sliding door, including framing
Transmittance / Resistance	U_s , R_s , U_t , R_t	U and R-values for s = balcony slab + curb t = combined glazing + slab
Surface Temperature Index ¹	T_i	0 = exterior temperature 1 = interior temperature
Linear Transmittance	ψ	Incremental increase in transmittance per linear length of slab

¹Assumptions and limitations for surface temperatures identified in ASHRAE 1365-RP

Scenarios

Scenario	Description
A	Window wall thermal break located at concrete slab, un-insulated glazing frame
B	Window wall thermal break located at Isokorb module, insulated glazing frame

Assembly Performance Indicators

Base Assembly – Glazed Door

Scenario	$U_{\text{centre of glass}}$ Btu/ft ² · hr · °F (W/m ² K)	U_g Btu/ft ² · hr · °F (W/m ² K)
A	0.321 (1.82)	0.532 (3.02)
B	0.321 (1.82)	0.502 (2.85)

Slab Linear Transmittance

Scenario	R_t ft ² · hr · °F / Btu (m ² K / W)	U_t Btu/ft ² · hr · °F (W/m ² K)	ψ^2 Btu/ft · hr · °F (W/m K)
A	R-2.1 (0.37)	0.478 (2.71)	0.256 (0.442)
B	R-2.2 (0.39)	0.448 (2.55)	0.226 (0.392)

Balcony Only

R_s ft ² · hr · °F / Btu (m ² K / W)	U_s Btu/ft ² · hr · °F (W/m ² K)
R-4.7 (0.83)	0.213 (1.21)
R-5.3 (0.93)	0.189 (1.07)

²Transmittance not based on an opaque wall clear field value. See Part 1 Dealing with Floor to Floor Glazing.

Temperature Indices

	A	B	
T_{i1}	0.19	0.19	Min T on window frame, middle of track at top of door (below slab)
T_{i2}	0.51	0.51	Min T on window glass, top middle corner of door glazing (below slab)
T_{i3}	0.73	0.81	Min T on slab, along deflection header, on fixed window side

Detail 9.1.16

Exterior Insulated 2"x6" Steel Stud (16" o.c.) Wall Assembly with FRP Vertical Brackets and Rail System Supporting Metal Cladding and Sliding Door – Intermittently Attached Balcony and Sliding Door Intersection

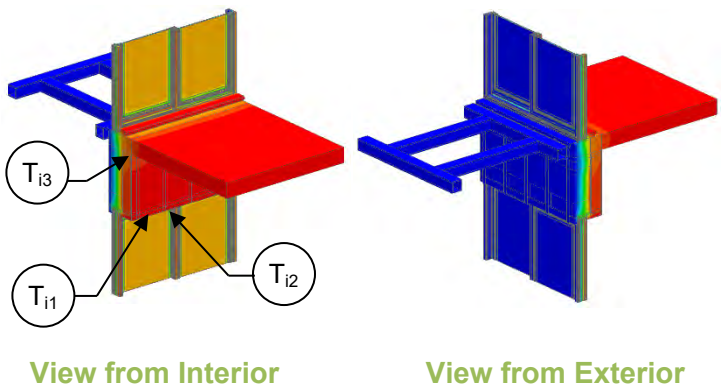

Thermal Performance Indicators

Assembly 1D (Nominal) R-Value	R_{1D}	R-3.2 (0.56 RSI) + exterior insulation
Transmittance without Anomaly	U_g	U-value for glazed sliding door, including framing
Transmittance / Resistance	U_t, R_t	U and R-values for t = combined glazing + slab
Surface Temperature Index ¹	T_i	0 = exterior temperature 1 = interior temperature
Linear Transmittance	ψ	Incremental increase in transmittance per linear length
Point Transmittance	χ	Incremental increase in transmittance for knife edge penetration

¹Assumptions and limitations for surface temperatures identified in ASHRAE 1365-RP

Nominal (1D) vs. Assembly Performance Indicators

Base Assembly – Wall

Exterior Insulation 1D R-Value (RSI)	R_{1D} ft ² ·hr·°F / Btu (m ² K / W)	R_o ft ² ·hr·°F / Btu (m ² K / W)	U_o Btu/ft ² ·hr ·°F (W/m ² K)
R-42 (7.40)	R-45.2 (7.96)	R-40.0 (7.04)	0.025 (0.14)

Base Assembly – Glazed Door

$U_{\text{centre of glass}}$ Btu/ft ² ·hr ·°F (W/m ² K)	U_g Btu/ft ² ·hr ·°F (W/m ² K)
0.269 (1.53)	0.329 (1.87)

Balcony Transition Transmittance

Exterior Insulation 1D R-Value (RSI)	R_t ft ² ·hr·°F / Btu (m ² K / W)	U_t Btu/ft ² ·hr ·°F (W/m ² K)	$\psi_{\text{Door_Head}}$ Btu/ft ·hr ·°F (W/m K)	$\psi_{\text{Door_Sill}}$ Btu/ft ·hr ·°F (W/m K)	$\chi_{\text{KnifeEdge}}$ Btu/hr °F (W/K)
R-42 (7.40)	R-3.8 (0.68)	0.260 (1.48)	0.044 (0.076)	0.024 (0.042)	0.514 (0.271)

Temperature Indices

	A	
T_{i1}	0.48	Min T on window frame, middle of track at top of fixed window (below slab)
T_{i2}	0.55	Min T on window glass, top middle corner of door glazing (below slab)
T_{i3}	0.79	Min T on sheathing below slab, beside studs along track

Detail 9.1.17

Exterior and Interior Insulated 2"x6" Steel Stud (16" o.c.) Wall Assembly with FRP Vertical Brackets and Rail System Supporting Metal Cladding with R-19 Batt in Stud Cavity and Sliding Door – Intermittently Attached Balcony and Sliding Door Intersection

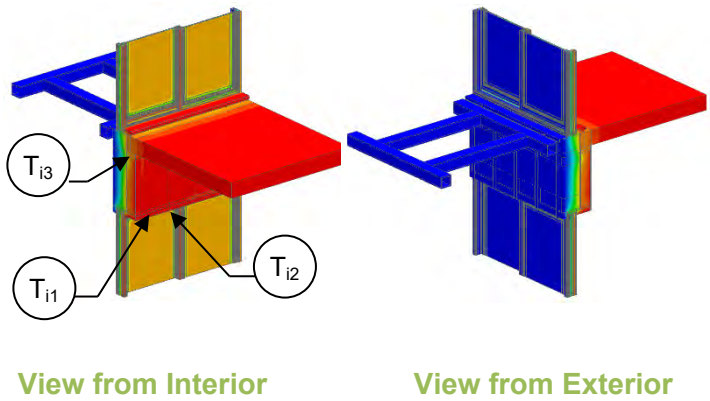

Thermal Performance Indicators

Assembly 1D (Nominal) R-Value	R_{1D}	R-21.3 (3.75 RSI) + exterior insulation
Transmittance without Anomaly	U_g	U-value for glazed sliding door, including framing
Transmittance / Resistance	U_t, R_t	U and R-values for t = combined glazing + slab
Surface Temperature Index ¹	T_i	0 = exterior temperature 1 = interior temperature
Linear Transmittance	ψ	Incremental increase in transmittance per linear length
Point Transmittance	χ	Incremental increase in transmittance for knife edge penetration

¹Assumptions and limitations for surface temperatures identified in ASHRAE 1365-RP

Nominal (1D) vs. Assembly Performance Indicators

Base Assembly – Wall

Exterior Insulation 1D R-Value (RSI)	R_{1D} ft ² ·hr·°F / Btu (m ² K / W)	R_o ft ² ·hr·°F / Btu (m ² K / W)	U_o Btu/ft ² ·hr ·°F (W/m ² K)
R-42 (7.40)	R-63.3 (11.15)	R-48.3 (8.51)	0.021 (0.12)

Base Assembly – Glazed Door

$U_{\text{centre of glass}}$ Btu/ft ² ·hr ·°F (W/m ² K)	U_g Btu/ft ² ·hr ·°F (W/m ² K)
0.269 (1.53)	0.329 (1.87)

Balcony Transition Transmittance

Exterior Insulation 1D R-Value (RSI)	R_t ft ² ·hr·°F / Btu (m ² K / W)	U_t Btu/ft ² ·hr ·°F (W/m ² K)	$\psi_{\text{Door_Head}}$ Btu/ft ·hr ·°F (W/m K)	$\psi_{\text{Door_Sill}}$ Btu/ft ·hr ·°F (W/m K)	$\chi_{\text{KnifeEdge}}$ Btu/hr °F (W/K)
R-42 (7.40)	R-3.9 (0.68)	0.258 (1.46)	0.041 (0.071)	0.035 (0.061)	0.495 (0.261)

Temperature Indices

	A	
T_{i1}	0.48	Min T on window frame, middle of track at top of fixed window (below slab)
T_{i2}	0.55	Min T on window glass, top middle corner of door glazing (below slab)
T_{i3}	0.60	Min T on sheathing below slab, beside studs along track

Detail 9.1.18

Exterior Insulated 2" x 6" Steel Stud (16" o.c.) Wall Assembly with Vertical Clips (24" o.c.) Supporting Cladding and Sliding Door – Concrete Balcony and Curb Intersection

Thermal Performance Indicators

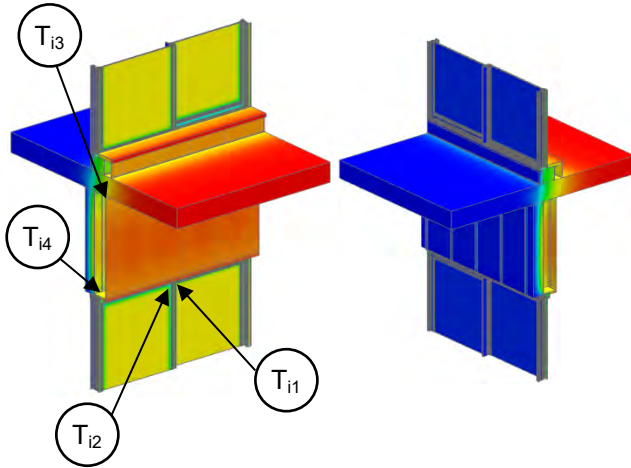

Assembly 1D (Nominal) R-Value	R_{1D}	R-3.2 (0.56 RSI) + exterior insulation
Transmittance / Resistance without Anomaly	U_o, R_o, U_g	U- and R-value for o = "clear wall" g = glazed sliding door, including framing
Transmittance / Resistance	U_s, R_s, U_t, R_t	U and R-values for s = balcony slab + curb t = combined glazing, wall + slab
Surface Temperature Index	T_i	0 = exterior temperature 1 = interior temperature
Linear Transmittance	ψ	Incremental increase in transmittance per linear length

View from Interior View from Exterior

Nominal (1D) vs. Assembly Performance Indicators

Base Assembly – Wall

Exterior Insulation 1D R-Value (RSI)	R_{1D} ft ² ·hr·°F / Btu (m ² K / W)	R_o ft ² ·hr·°F / Btu (m ² K / W)	U_o Btu/ft ² ·hr·°F (W/m ² K)
R-4.2 (0.74)	R-7.4 (1.30)	R-6.9 (1.22)	0.144 (0.82)
R-8.4 (1.48)	R-11.6 (2.04)	R-9.8 (1.72)	0.102 (0.58)
R-12.6 (2.22)	R-15.8 (2.78)	R-12.0 (2.11)	0.083 (0.47)
R-16.8 (2.96)	R-20.0 (3.52)	R-14.5 (2.55)	0.069 (0.39)
R-21.0 (3.70)	R-24.2 (4.26)	R-16.7 (2.95)	0.060 (0.34)

Base Assembly – Glazed Door

$U_{\text{centre of glass}}$ Btu/ft ² ·hr·°F (W/m ² K)	U_g Btu/ft ² ·hr·°F (W/m ² K)
0.321 (1.82)	0.552 (3.13)

Balcony Transition Transmittance

Exterior Insulation 1D R-Value (RSI)	R_t ft ² ·hr·°F / Btu (m ² K / W)	U_t Btu/ft ² ·hr·°F (W/m ² K)	Ψ Door Head Btu/ft·hr·°F (W/m K)	Ψ Door Sill Btu/ft·hr·°F (W/m K)	Ψ Balcony Btu/ft·hr·°F (W/m K)
R-4.2 (0.74)	R-2.3 (0.41)	0.427 (2.43)	0.145 (0.251)	0.065 (0.112)	0.394 (0.682)
R-8.4 (1.48)	R-2.4 (0.42)	0.415 (2.35)	0.161 (0.279)		0.444 (0.769)
R-12.6 (2.22)	R-2.4 (0.43)	0.409 (2.32)	0.154 (0.267)		0.477 (0.825)
R-16.8 (2.96)	R-2.5 (0.44)	0.404 (2.30)	0.176 (0.305)		0.475 (0.822)
R-21.0 (3.70)	R-2.5 (0.44)	0.401 (2.28)	0.181 (0.313)		0.483 (0.836)

Balcony Only

R_s ft ² ·hr·°F / Btu (m ² K / W)	U_s Btu/ft ² ·hr·°F (W/m ² K)
R-3.0 (0.52)	0.338 (1.92)
R-2.6 (0.46)	0.381 (2.16)
R-2.4 (0.43)	0.409 (2.32)
R-2.5 (0.43)	0.407 (2.31)
R-2.4 (0.43)	0.414 (2.35)

Temperature Indices

	R4.2	R8.4	R12.6	R16.8	R21.0	
T_{i1}	0.13	0.13	0.13	0.13	0.13	Min T on window frame at centre mullion of sliding door
T_{i2}	0.44	0.44	0.44	0.44	0.44	Min T on window glass at 30 mm away from sight edge at fixed glazing
T_{i3}	0.75	0.72	0.73	0.74	0.75	Min T on slab at wall ceiling
T_{i4}	0.50	0.48	0.49	0.50	0.50	Min T on sheathing at sliding door head

Detail 9.1.19

Exterior and Interior Insulated 2" x 6" Steel Stud (16" o.c.) Wall Assembly with Vertical Clips (24" o.c.) Supporting Cladding with R-19 Batt in Stud Cavity and Sliding Door – Concrete Balcony and Curb Intersection

Thermal Performance Indicators

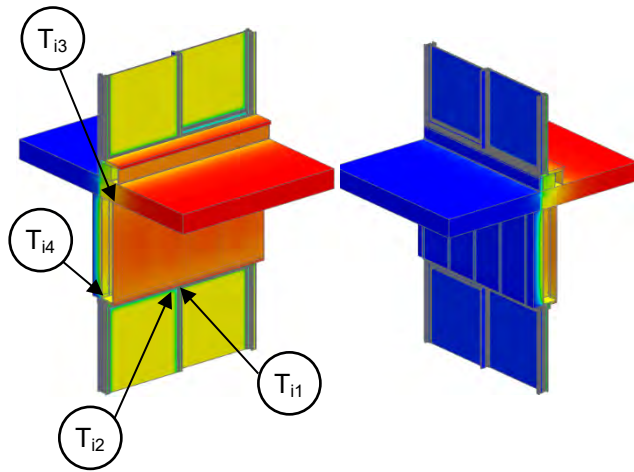

View from Interior

View from Exterior

Assembly 1D (Nominal) R-Value	R_{1D}	R-21.3 (3.75 RSI) + exterior insulation
Transmittance / Resistance without Anomaly	U_o, R_o, U_g	U- and R-value for o = "clear wall" g = glazed sliding door, including framing
Transmittance / Resistance	U_s, R_s, U_t, R_t	U and R-values for s = balcony slab + curb t = combined glazing, wall + slab
Surface Temperature Index	T_i	0 = exterior temperature 1 = interior temperature
Linear Transmittance	ψ	Incremental increase in transmittance per linear length

Nominal (1D) vs. Assembly Performance Indicators

Base Assembly – Wall

Exterior Insulation 1D R-Value (RSI)	R_{1D} ft ² ·hr·°F / Btu (m ² K / W)	R_o ft ² ·hr·°F / Btu (m ² K / W)	U_o Btu/ft ² ·hr ·°F (W/m ² K)
R-4.2 (0.74)	R-25.5 (4.49)	R-15.2 (2.67)	0.066 (0.37)
R-8.4 (1.48)	R-29.7 (5.23)	R-17.7 (3.12)	0.056 (0.32)
R-12.6 (2.22)	R-33.9 (5.97)	R-19.8 (3.48)	0.051 (0.29)
R-16.8 (2.96)	R-38.1 (6.71)	R-22.3 (3.92)	0.045 (0.26)
R-21.0 (3.70)	R-42.3 (7.45)	R-24.5 (4.32)	0.041 (0.23)

Base Assembly – Glazed Door

$U_{\text{centre of glass}}$ Btu/ft ² ·hr ·°F (W/m ² K)	U_g Btu/ft ² ·hr ·°F (W/m ² K)
0.321 (1.82)	0.552 (3.13)

Balcony Transition Transmittance

Exterior Insulation 1D R-Value (RSI)	R_t ft ² ·hr·°F / Btu (m ² K / W)	U_t Btu/ft ² ·hr ·°F (W/m ² K)	Ψ Door Head Btu/ft ·hr ·°F (W/m K)	Ψ Door Sill Btu/ft ·hr ·°F (W/m K)	Ψ Balcony Btu/ft ·hr ·°F (W/m K)
R-4.2 (0.74)	R-2.5 (0.44)	0.400 (2.27)	0.159 (0.276)	0.065 (0.112)	0.466 (0.807)
R-8.4 (1.48)	R-2.5 (0.44)	0.396 (2.25)	0.159 (0.275)		0.464 (0.804)
R-12.6 (2.22)	R-2.5 (0.45)	0.393 (2.23)	0.151 (0.262)		0.471 (0.815)
R-16.8 (2.96)	R-2.6 (0.45)	0.390 (2.28)	0.162 (0.280)		0.458 (0.793)
R-21.0 (3.70)	R-2.6 (0.45)	0.389 (2.21)	0.163 (0.282)		0.458 (0.793)

Balcony Only

R_s ft ² ·hr·°F / Btu (m ² K / W)	U_s Btu/ft ² ·hr ·°F (W/m ² K)
R-2.5 (0.44)	0.399 (2.27)
R-2.5 (0.44)	0.398 (2.26)
R-2.5 (0.44)	0.404 (2.29)
R-2.5 (0.45)	0.393 (2.23)
R-2.5 (0.45)	0.393 (2.23)

Temperature Indices

	R4.2	R8.4	R12.6	R16.8	R21.0	
T_{i1}	0.13	0.13	0.13	0.13	0.13	Min T on window frame at centre mullion of sliding door
T_{i2}	0.43	0.43	0.43	0.43	0.43	Min T on window glass at 30 mm away from sight edge at fixed glazing
T_{i3}	0.71	0.69	0.70	0.71	0.71	Min T on slab at wall ceiling
T_{i4}	0.41	0.39	0.40	0.40	0.41	Min T on sheathing at sliding door head

Detail 9.1.20

Exterior Insulated 2" x 6" Steel Stud (16" o.c.) Wall Assembly with Vertical Clips (24" o.c.) Supporting Cladding and Sliding Door – Structural Thermal Break at Concrete Balcony and Curb Intersection

Thermal Performance Indicators

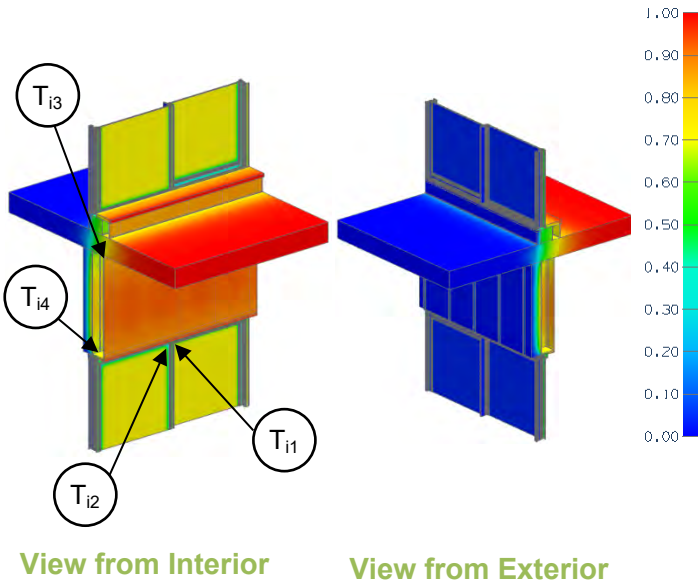

Assembly 1D (Nominal) R-Value	R _{1D}	R-3.2 (0.56 RSI) + exterior insulation
Transmittance / Resistance without Anomaly	U _o , R _o , U _g	U- and R-value for o = "clear wall" g = glazed sliding door, including framing
Transmittance / Resistance	U _s , R _s , U _t , R _t	U and R-values for s = balcony slab + curb t = combined glazing, wall + slab
Surface Temperature Index	T _i	0 = exterior temperature 1 = interior temperature
Linear Transmittance	ψ	Incremental increase in transmittance per linear length

View from Interior View from Exterior

Nominal (1D) vs. Assembly Performance Indicators

Base Assembly – Wall

Exterior Insulation 1D R-Value (RSI)	R _{1D} ft ² ·hr·°F / Btu (m ² K / W)	R _o ft ² ·hr·°F / Btu (m ² K / W)	U _o Btu/ft ² ·hr ·°F (W/m ² K)
R-4.2 (0.74)	R-7.4 (1.30)	R-6.9 (1.22)	0.144 (0.82)
R-8.4 (1.48)	R-11.6 (2.04)	R-9.8 (1.72)	0.102 (0.58)
R-12.6 (2.22)	R-15.8 (2.78)	R-12.0 (2.11)	0.083 (0.47)
R-16.8 (2.96)	R-20.0 (3.52)	R-14.5 (2.55)	0.069 (0.39)
R-21.0 (3.70)	R-24.2 (4.26)	R-16.7 (2.95)	0.060 (0.34)

Base Assembly – Glazed Door

U _{centre of glass} Btu/ft ² ·hr ·°F (W/m ² K)	U _g Btu/ft ² ·hr ·°F (W/m ² K)
0.321 (1.82)	0.552 (3.13)

Balcony Transition Transmittance

Exterior Insulation 1D R-Value (RSI)	R _t ft ² ·hr·°F / Btu (m ² K / W)	U _t Btu/ft ² ·hr ·°F (W/m ² K)	ψ Door Head Btu/ft ·hr ·°F (W/m K)	ψ Door Sill Btu/ft ·hr ·°F (W/m K)	ψ Balcony Btu/ft ·hr ·°F (W/m K)
R-4.2 (0.74)	R-2.5 (0.44)	0.399 (2.26)	0.145 (0.251)	0.065 (0.112)	0.094 (0.163)
R-8.4 (1.48)	R-2.6 (0.46)	0.386 (2.19)	0.161 (0.279)		0.144 (0.249)
R-12.6 (2.22)	R-2.6 (0.46)	0.382 (2.17)	0.154 (0.267)		0.193 (0.333)
R-16.8 (2.96)	R-2.6 (0.47)	0.378 (2.15)	0.176 (0.305)		0.200 (0.346)
R-21.0 (3.70)	R-2.7 (0.47)	0.376 (2.14)	0.181 (0.313)		0.218 (0.377)

Balcony Only

R _s ft ² ·hr·°F / Btu (m ² K / W)	U _s Btu/ft ² ·hr ·°F (W/m ² K)
R-12.4 (2.18)	0.081 (0.46)
R-8.1 (1.43)	0.123 (0.70)
R-6.1 (1.07)	0.165 (0.94)
R-5.8 (1.03)	0.171 (0.97)
R-5.4 (0.94)	0.187 (1.06)

Temperature Indices

	R4.2	R8.4	R12.6	R16.8	R21.0	
T _{i1}	0.13	0.13	0.13	0.13	0.13	Min T on window frame at centre mullion of sliding door
T _{i2}	0.44	0.44	0.44	0.44	0.44	Min T on window glass at 30 mm away from sight edge at fixed glazing
T _{i3}	0.84	0.84	0.84	0.84	0.84	Min T on slab at wall ceiling
T _{i4}	0.50	0.48	0.49	0.50	0.50	Min T on sheathing at sliding door head

Detail 9.1.21

Exterior and Interior Insulated 2" x 6" Steel Stud (16" o.c.) Wall Assembly with Vertical Clips (24" o.c.) Supporting Cladding with R-19 Batt in Stud Cavity and Sliding Door – Structural Thermal Break at Concrete Balcony and Curb Intersection

Thermal Performance Indicators

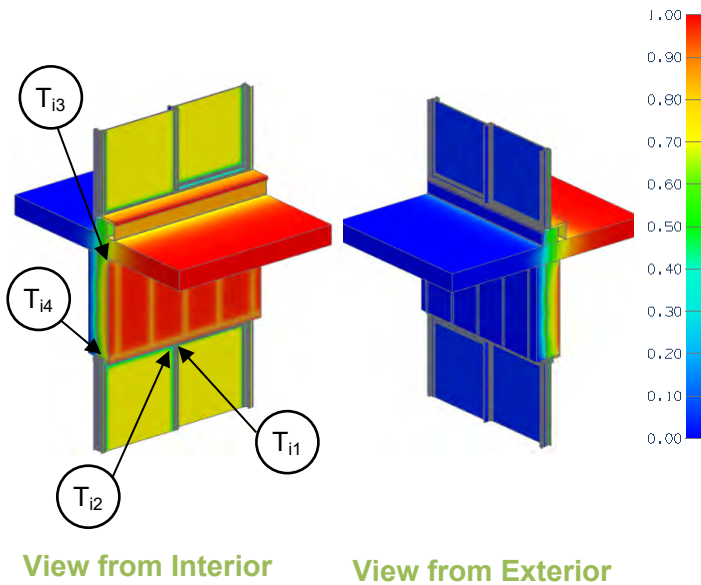

Assembly 1D (Nominal) R-Value	R_{1D}	R-21.3 (3.75 RSI) + exterior insulation
Transmittance / Resistance without Anomaly	U_o, R_o, U_g	U- and R-value for o = "clear wall" g = glazed sliding door, including framing
Transmittance / Resistance	U_s, R_s, U_t, R_t	U and R-values for s = balcony slab + curb t = combined glazing, wall + slab
Surface Temperature Index	T_i	0 = exterior temperature 1 = interior temperature
Linear Transmittance	ψ	Incremental increase in transmittance per linear length

View from Interior

View from Exterior

Nominal (1D) vs. Assembly Performance Indicators

Base Assembly – Wall

Exterior Insulation 1D R-Value (RSI)	R_{1D} ft ² ·hr·°F / Btu (m ² K / W)	R_o ft ² ·hr·°F / Btu (m ² K / W)	U_o Btu/ft ² ·hr ·°F (W/m ² K)
R-4.2 (0.74)	R-25.5 (4.49)	R-15.2 (2.67)	0.066 (0.37)
R-8.4 (1.48)	R-29.7 (5.23)	R-17.7 (3.12)	0.056 (0.32)
R-12.6 (2.22)	R-33.9 (5.97)	R-19.8 (3.48)	0.051 (0.29)
R-16.8 (2.96)	R-38.1 (6.71)	R-22.3 (3.92)	0.045 (0.26)
R-21.0 (3.70)	R-42.3 (7.45)	R-24.5 (4.32)	0.041 (0.23)

Base Assembly – Glazed Door

$U_{\text{centre of glass}}$ Btu/ft ² ·hr ·°F (W/m ² K)	U_g Btu/ft ² ·hr ·°F (W/m ² K)
0.321 (1.82)	0.552 (3.13)

Balcony Transition Transmittance

Exterior Insulation 1D R-Value (RSI)	R_t ft ² ·hr·°F / Btu (m ² K / W)	U_t Btu/ft ² ·hr ·°F (W/m ² K)	ψ Door Head Btu/ft ·hr ·°F (W/m K)	ψ Door Sill Btu/ft ·hr ·°F (W/m K)	ψ Balcony Btu/ft ·hr ·°F (W/m K)
R-4.2 (0.74)	R-2.7 (0.47)	0.375 (2.13)	0.159 (0.276)	0.065 (0.112)	0.201 (0.347)
R-8.4 (1.48)	R-2.7 (0.47)	0.371 (2.11)	0.159 (0.275)		0.199 (0.344)
R-12.6 (2.22)	R-2.7 (0.48)	0.369 (2.10)	0.151 (0.262)		0.218 (0.377)
R-16.8 (2.96)	R-2.7 (0.48)	0.368 (2.09)	0.162 (0.280)		0.218 (0.378)
R-21.0 (3.70)	R-2.7 (0.48)	0.367 (2.08)	0.163 (0.282)		0.224 (0.388)

Balcony Only

R_s ft ² ·hr·°F / Btu (m ² K / W)	U_s Btu/ft ² ·hr ·°F (W/m ² K)
R-5.8 (1.02)	0.172 (0.98)
R-5.9 (1.03)	0.171 (0.97)
R-5.4 (0.94)	0.187 (1.06)
R-5.3 (0.94)	0.187 (1.06)
R-5.2 (0.92)	0.192 (1.09)

Temperature Indices

	R4.2	R8.4	R12.6	R16.8	R21.0	
T_{i1}	0.13	0.13	0.13	0.13	0.13	Min T on window frame at centre mullion of sliding door
T_{i2}	0.43	0.43	0.43	0.43	0.43	Min T on window glass at 30 mm away from sight edge at fixed glazing
T_{i3}	0.82	0.82	0.82	0.82	0.82	Min T on slab at wall ceiling
T_{i4}	0.41	0.37	0.40	0.40	0.41	Min T on sheathing at sliding door head

10.0 Roofs

Detail 10.1.1	B.10.1
Exterior Insulated Sloped Metal Roof with Metal Sub-Girts (12" o.c.) Supporting Standing Seam Metal Roof – Clear Roof	
Detail 10.1.2	B.10.2
Exterior Insulated Sloped Metal Roof with Metal Sub-Girts (24" o.c.) Supporting Standing Seam Metal Roof – Clear Roof	
Detail 10.1.3	B.10.3
Exterior Insulated Sloped Metal Roof with Metal Sub-Girts (36" o.c.) Supporting Standing Seam Metal Roof – Clear Roof	
Detail 10.1.4	B.10.4
Insulated Sheet Steel Roof Supported by Thermal Chairs – Baseline System – Clear Roof	
Detail 10.1.5	B.10.5
Insulated Sheet Steel Roof Supported by Thermal Chairs – Additional Scenarios – Clear Roof	
Detail 10.1.6	B.10.6
Insulated Sheet Steel Roof Supported by Thermal Chairs – Additional Insulation Type Scenarios – Clear Roof	
Detail 10.1.7	B.10.7
Insulated Standing Seam Roof Supported by Thermal Chairs – Clear Wall	
Detail 10.1.8	B.10.8
Standing Seam Roof with Draped Insulation – Clear Wall	
Detail 10.1.9	B.10.9
Exterior Insulated Low Sloped Roof (3.4 fasteners/m ² , 0.3 fasteners/ft ²) – Clear Roof Assembly	
Detail 10.1.10	B.10.10
Exterior Insulated Sloped Metal Roof with Bearing Plates 18" x 48" spacing – Clear Roof Assembly	
Detail 10.1.11	B.10.11
Exterior Insulated Sloped Metal Roof with High Compressive Strength Mineral Wool Insulation and with Bearing Plates 18" x 48" spacing – Clear Roof Assembly	
Detail 10.1.12	B.10.12
Ventilated Wood Frame Low Sloped Roof – Clear Roof Assembly	
Detail 10.1.13	B.10.13
Exterior Insulated Low Sloped Roof (10.8 fasteners/m ² , 1 fasteners/ft ²)– Clear Roof Assembly	
Detail 10.1.14	B.10.14
Sloped Wood Framed Roof with Insulation at Ceiling	

Detail 10.1.15	B.10.15
Sloped Wood Framed Roof with Insulation at Roof Sheathing	
Detail 10.1.16	B.10.16
Exterior Insulated Low Sloped Roof with Fully Adhered Roof Membrane and Mineral Wool Insulation – Clear Roof Assembly	
Detail 10.1.17	B.10.17
Exterior Insulated Low Sloped Roof with Fully Adhered Roof Membrane and Mineral Wool and Polyisocyanurate Insulation – Clear Roof Assembly	
Detail 10.2.1	B.10.18
Exterior Insulated Sloped Metal Roof with Metal Sub-Girts (24” o.c.) Supporting Metal Roof – Ridge Intersection	
Detail 10.2.2	B.10.19
Insulated Concrete Slab – Concrete Curb or Wall Intersection	
Detail 10.2.3	B.10.20
Owens Corning Insulated Projected Membrane Roof – Floating Concrete Wall Intersection	
Detail 10.2.4	21
Exterior Insulated Sloped Metal Roof with Metal Sub-Girts (24” o.c.) Supporting Standing Seam Metal Roof and Curtain Wall – Roof to Wall Intersection with Through Wall Structural Beam and Continuous Through Wall Structural Metal Deck	
Detail 10.2.5	B.10.22
Exterior Insulated Sloped Metal Roof with Metal Sub-Girts (24” o.c.) Supporting Standing Seam Metal Roof and Curtain Wall – Roof to Wall Intersection with Through Wall Structural Beam and Thermally Broken Structural Metal Deck	
Detail 10.2.6	B.10.23
Exterior Insulated Sloped Metal Roof with Metal Sub-Girts (24” o.c.) Supporting Standing Seam Metal Roof and Curtain Wall – Roof to Wall Intersection with Through Wall Structural Beam and Fully Insulated Soffit	
Detail 10.2.7	B.10.24
Aluminum Framed Double Glazed Skylight – Exterior Insulated Concrete Curb Intersection	
Detail 10.3.1	B.10.25
Exterior Insulated Conventional Flat Roof – Roof Anchor	
Detail 10.3.2	B.10.26
Exterior Insulated Conventional Flat Roof – Armatherm Thermal Break under Roof Anchor	
Detail 10.3.3	B.10.27
Exterior Insulated Conventional Low-Sloped Roof – Roof Anchor	

Detail 10.3.4	B.10.28
Exterior Insulated Conventional Low-Sloped Roof – Thermal Break in Roof Anchor	
Detail 10.4.1	B.10.29
Exterior Insulated Low Sloped Roof with Fully Adhered Roof Membrane and Mineral Wool Insulation - Flange-Style Drain Penetration	
Detail 10.4.2	B.10.30
Exterior Insulated Low Sloped Roof with Fully Adhered Roof Membrane and Mineral Wool and Polyisocyanurate Insulation - Flange-Style Drain Penetration	

Detail 10.1.1

Exterior Insulated Sloped Metal Roof with Metal Sub-Girts (12" o.c.) Supporting Standing Seam Metal Roof – Clear Roof

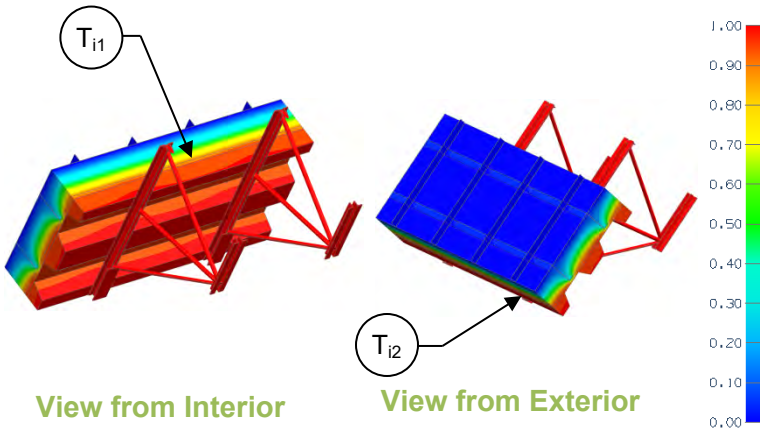

Thermal Performance Indicators

Assembly 1D (Nominal) R Value	R_{1D}	R-3.0 (0.53 RSI) + exterior insulation
Transmittance / Resistance	U_o, R_o	"clear field" U- and R-value
Surface Temperature Index ¹	T_i	0 = exterior temperature 1 = interior temperature

¹Surface temperatures are a result of steady-state conductive heat flow with constant heat transfer coefficients. Limitations are identified in final report.

Nominal (1D) vs. Assembly Performance Indicators

Exterior Insulation 1D R-Value (RSI)	R_{1D} ft ² ·hr·°F / Btu (m ² K / W)	R_o ft ² ·hr·°F / Btu (m ² K / W)	U_o Btu/ft ² ·hr·°F (W/m ² K)
R-20 (3.52)	R-23 (4.05)	R-7.0 (1.24)	0.142 (0.81)
R-30 (5.28)	R-33 (5.81)	R-8.0 (1.41)	0.125 (0.71)
R-40 (7.04)	R-43 (7.57)	R-8.9 (1.56)	0.113 (0.64)

Temperature Indices

	R20	R30	R40	
T_{i1}	0.89	0.90	0.91	Min T on sheathing, closest to girt flange between joists
T_{i2}	0.93	0.94	0.94	Max T on sheathing above end bearings away from girts

Detail 10.1.2

Exterior Insulated Sloped Metal Roof with Metal Sub-Girts (24" o.c.) Supporting Standing Seam Metal Roof – Clear Roof

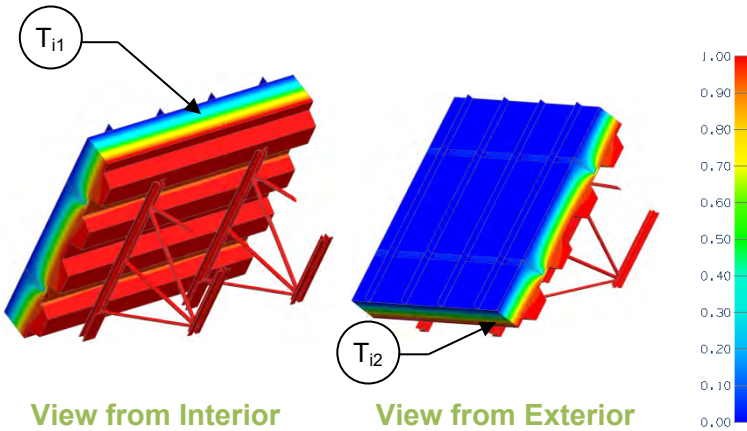

Thermal Performance Indicators

Assembly 1D (Nominal) R Value	R_{1D}	R-3.0 (0.53 RSI) + exterior insulation
Transmittance / Resistance	U_o, R_o	"clear field" U- and R-value
Surface Temperature Index ¹	T_i	0 = exterior temperature 1 = interior temperature

¹Surface temperatures are a result of steady-state conductive heat flow with constant heat transfer coefficients. Limitations are identified in final report.

Nominal (1D) vs. Assembly Performance Indicators

Exterior Insulation 1D R-Value (RSI)	R_{1D} ft ² ·hr·°F / Btu (m ² K / W)	R_o ft ² ·hr·°F / Btu (m ² K / W)	U_o Btu/ft ² ·hr·°F (W/m ² K)
R-20 (3.52)	R-23 (4.05)	R-10.6 (1.87)	0.094 (0.53)
R-30 (5.28)	R-33 (5.81)	R-12.8 (2.25)	0.078 (0.44)
R-40 (7.04)	R-43 (7.57)	R-14.7 (2.58)	0.068 (0.39)

Temperature Indices

	R20	R30	R40	
T_{i1}	0.90	0.91	0.92	Min T on sheathing, closest to girt flange between joists
T_{i2}	0.97	0.97	0.98	Max T on sheathing, above end bearings away from girts

Detail 10.1.3

Exterior Insulated Sloped Metal Roof with Metal Sub-Girts (36" o.c.) Supporting Standing Seam Metal Roof – Clear Roof

Thermal Performance Indicators

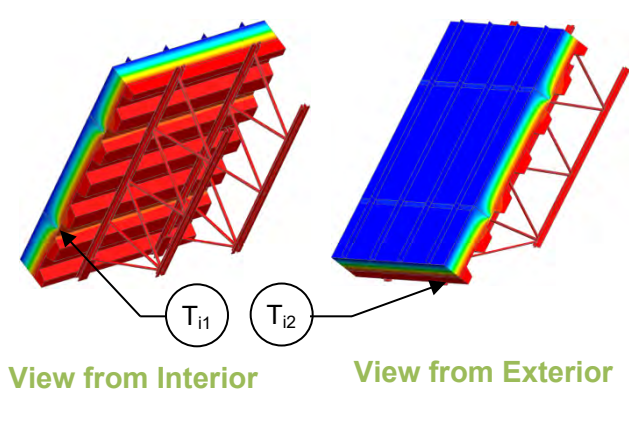

Assembly 1D (Nominal) R Value	R_{1D}	R-3.0 (0.53 RSI) + exterior insulation
Transmittance / Resistance	U_o, R_o	“clear field” U- and R-value
Surface Temperature Index ¹	T_i	0 = exterior temperature 1 = interior temperature

¹Surface temperatures are a result of steady-state conductive heat flow with constant heat transfer coefficients. Limitations are identified in final report.

Nominal (1D) vs. Assembly Performance Indicators

Exterior Insulation 1D R-Value (RSI)	R_{1D} ft ² ·hr·°F / Btu (m ² K / W)	R_o ft ² ·hr·°F / Btu (m ² K / W)	U_o Btu/ft ² ·hr ·°F (W/m ² K)
R-20 (3.52)	R-23 (4.05)	R-12.7 (2.25)	0.078 (0.45)
R-30 (5.28)	R-33 (5.81)	R-15.8 (2.79)	0.063 (0.36)
R-40 (7.04)	R-43 (7.57)	R-18.5 (3.25)	0.054 (0.31)

Temperature Indices

	R20	R30	R40	
T_{i1}	0.90	0.91	0.92	Min T on sheathing, at girt between joists
T_{i2}	0.97	0.98	0.98	Max T on sheathing, above end bearings away from girts

Detail 10.1.4

Insulated Sheet Steel Roof Supported by Thermal Chairs – Baseline System – Clear Roof

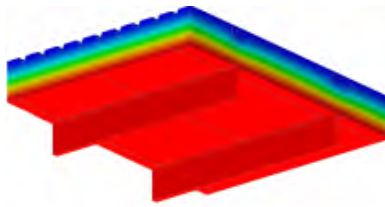

View from Interior

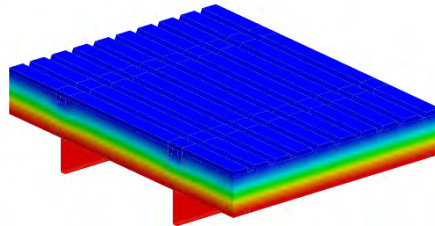

View from Exterior

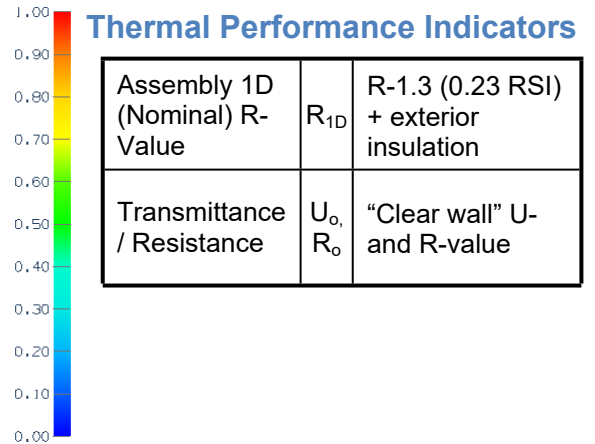

Nominal (1D) vs. Assembly Performance Indicators

Baseline System

Chair Spacing (in)	Purlin Spacing (in)	Exterior Insulation 1D R-Value (RSI)	R_{1D} ft ² ·hr·°F / Btu (m ² K / W)	R_o ft ² ·hr·°F / Btu (m ² K / W)	U_o Btu/ft ² ·hr ·°F (W/m ² K)
24	48	R-45 (7.95)	R-46.3 (8.15)	R-30.5 (5.38)	0.033 (0.186)
24	60	R-45 (7.95)	R-46.3 (8.15)	R-32.7 (5.76)	0.031 (0.174)
24	72	R-45 (7.95)	R-46.3 (8.15)	R-34.3 (6.04)	0.029 (0.166)
36	48	R-45 (7.95)	R-46.3 (8.15)	R-33.8 (5.96)	0.030 (0.168)
36	60	R-45 (7.95)	R-46.3 (8.15)	R-35.9 (6.32)	0.028 (0.158)
36	72	R-45 (7.95)	R-46.3 (8.15)	R-37.4 (6.58)	0.027 (0.152)
48	48	R-45 (7.95)	R-46.3 (8.15)	R-39.6 (6.97)	0.025 (0.143)
48	60	R-45 (7.95)	R-46.3 (8.15)	R-40.4 (7.11)	0.025 (0.141)
48	72	R-45 (7.95)	R-46.3 (8.15)	R-41.4 (7.29)	0.024 (0.137)

Sensitivity Analysis – Impact of Liner, Cladding, Chair and Purlin Thickness for 36” o.c. Chair Spacing and 48” o.c. Purlin Spacing

Steel Thickness	Exterior Insulation 1D R-Value (RSI)	R_{1D} ft ² ·hr·°F / Btu (m ² K / W)	Liner		Cladding		Chair		Purlins	
			R_o ft ² ·hr·°F / Btu (m ² K / W)	U_o Btu/ft ² ·hr ·°F (W/m ² K)	R_o ft ² ·hr·°F / Btu (m ² K / W)	U_o Btu/ft ² ·hr ·°F (W/m ² K)	R_o ft ² ·hr·°F / Btu (m ² K / W)	U_o Btu/ft ² ·hr ·°F (W/m ² K)		
24 Ga	R-45 (7.95)	R-46.3 (8.15)	R-33.8 (5.96)	0.030 (0.168)	R-33.8 (5.96)	0.030 (0.168)	R-34.1 (6.01)	0.029 (0.167)	-	-
18 Ga	R-45 (7.95)	R-46.3 (8.15)	R-33.8 (5.95)	0.030 (0.168)	R-33.7 (5.94)	0.030 (0.168)	R-33.8 (5.96)	0.030 (0.168)	-	-
14 Ga	R-45 (7.95)	R-46.3 (8.15)	-	-	R-33.7 (5.93)	0.030 (0.169)	R-33.6 (5.91)	0.030 (0.169)	R-33.8 (5.96)	0.030 (0.168)
6 Ga	R-45 (7.95)	R-46.3 (8.15)	-	-	-	-	-	-	R-33.8 (5.95)	0.030 (0.168)

Detail 10.1.5

Insulated Sheet Steel Roof Supported by Thermal Chairs – Additional Scenarios – Clear Roof

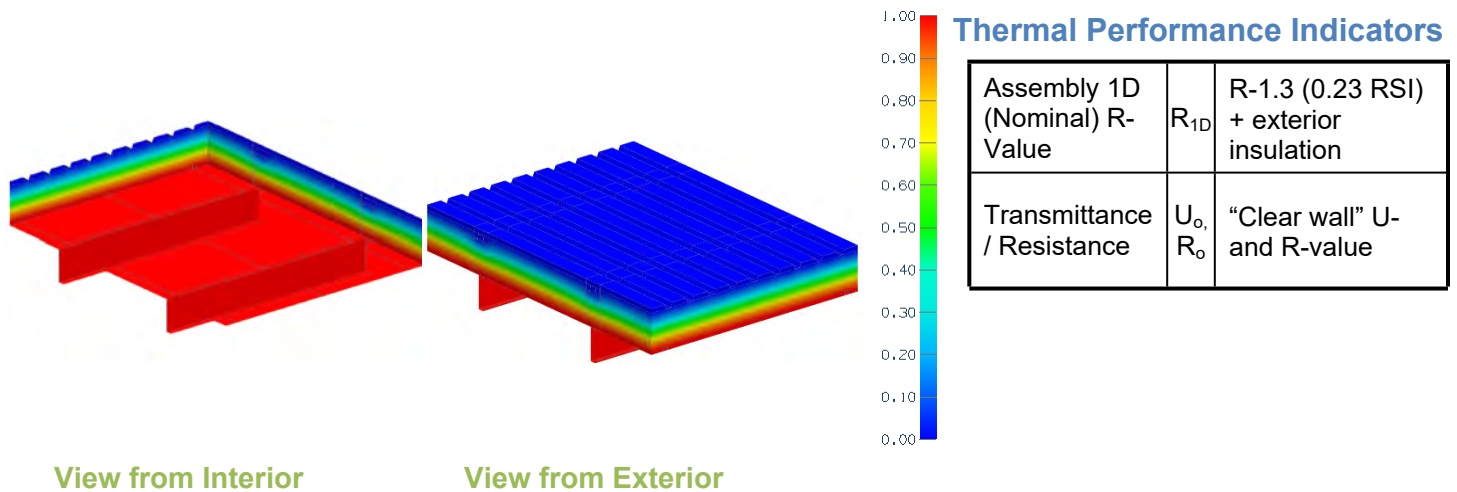

Nominal (1D) vs. Assembly Performance Indicators

Sensitivity Analysis – Impact of PVC Coated Thermal Chairs Spaced at 36” o.c. and Purlins Spaced at 48” o.c.

PVC Coating Thickness on Thermal Chairs and Outer Rails (mils)	Exterior Insulation 1D R-Value (RSI)	R_{1D} ft ² ·hr·°F / Btu (m ² K / W)	R_o ft ² ·hr·°F / Btu (m ² K / W)	U_o Btu/ft ² ·hr ·°F (W/m ² K)
0 Top, 0 Bottom	R-45 (7.95)	R-46.3 (8.15)	R-33.8 (5.96)	0.030 (0.168)
8 Top, 4 Bottom	R-45 (7.95)	R-46.3 (8.15)	R-34.2 (6.03)	0.029 (0.166)

Sensitivity Analysis – Impact of Thermal Tape Thickness for Thermal Chairs at 36” o.c. and Purlins at 48” o.c.

Tape Thickness (in)	Tape R-Value (RSI)	Exterior Insulation 1D R-Value (RSI)	R_{1D} ft ² ·hr·°F / Btu (m ² K / W)	R_o ft ² ·hr·°F / Btu (m ² K / W)	U_o Btu/ft ² ·hr ·°F (W/m ² K)
0	R-0 (0.00)	R-45 (7.95)	R-46.3 (8.15)	R-30.4 (5.36)	0.033 (0.187)
1/8	R-1 (0.23)	R-45 (7.95)	R-46.3 (8.15)	R-33.8 (5.96)	0.030 (0.168)
1/4	R-3 (0.45)	R-45 (7.95)	R-46.3 (8.15)	R-34.3 (6.04)	0.029 (0.166)

Sensitivity Analysis – Variable Material for Thermal Chairs at 36” o.c. and 48” o.c. Purlin Spacing

Thermal Chair Material	Exterior Insulation 1D R-Value (RSI)	R_{1D} ft ² ·hr·°F / Btu (m ² K / W)	R_o ft ² ·hr·°F / Btu (m ² K / W)	U_o Btu/ft ² ·hr ·°F (W/m ² K)
Steel	R-45 (7.95)	R-46.3 (8.15)	R-33.8 (5.96)	0.030 (0.168)
Plastic	R-45 (7.95)	R-46.3 (8.15)	R-37.1 (6.53)	0.027 (0.153)

Sensitivity Analysis – Reduction in Thermal Chair area for 36”o.c. Chair Spacing and 48”o.c. Purlin Spacing

Thermal Chair Material	Exterior Insulation 1D R-Value (RSI)	R_{1D} ft ² ·hr·°F / Btu (m ² K / W)	R_o ft ² ·hr·°F / Btu (m ² K / W)	U_o Btu/ft ² ·hr ·°F (W/m ² K)
Baseline	R-45 (7.95)	R-46.3 (8.15)	R-33.8 (5.96)	0.030 (0.168)
20% Reduction	R-45 (7.95)	R-46.3 (8.15)	R-34.0 (5.98)	0.029 (0.167)
30% Reduction	R-45 (7.95)	R-46.3 (8.15)	R-34.4 (6.05)	0.029 (0.165)
40% Reduction	R-45 (7.95)	R-46.3 (8.15)	R-34.6 (6.10)	0.029 (0.164)

Detail 10.1.6

Insulated Sheet Steel Roof Supported by Thermal Chairs – Additional Insulation Type Scenarios – Clear Roof

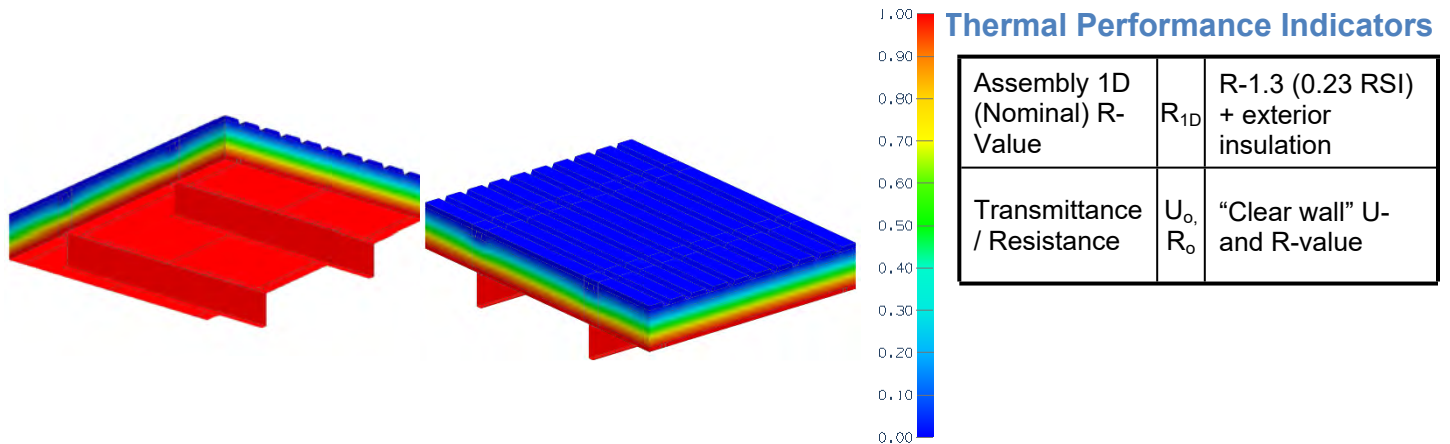

View from Interior

View from Exterior

Nominal (1D) vs. Assembly Performance Indicators

Sensitivity Analysis – Impact of Insulation Type and Thickness for Thermal Chairs spaced at 36” o.c. and Purlins Spaced at 48” o.c.

Chair Thickness (in)	Insulation Thickness (in)	R-4.2/inch insulation			R-5/inch insulation			R-6/inch insulation		
		Exterior Insulation 1D R-Value (RSI)	R_o ft ² ·hr·°F / Btu (m ² K / W)	U_o Btu/ft ² ·hr ·°F (W/m ² K)	Exterior Insulation 1D R-Value (RSI)	R_o ft ² ·hr·°F / Btu (m ² K / W)	U_o Btu/ft ² ·hr ·°F (W/m ² K)	Exterior Insulation 1D R-Value (RSI)	R_o ft ² ·hr·°F / Btu (m ² K / W)	U_o Btu/ft ² ·hr ·°F (W/m ² K)
4 ¼	5	R-21 (3.70)	R-19.4 (3.41)	0.052 (0.293)	R-25 (4.40)	R-22.2 (3.91)	0.045 (0.256)	R-30 (5.29)	R-25.6 (4.51)	0.039 (0.222)
6	6 ¾	R-28 (4.99)	R-25.0 (4.40)	0.040 (0.227)	R-34 (5.95)	R-28.6 (5.04)	0.035 (0.198)	R-41 (7.13)	R-32.9 (5.80)	0.030 (0.172)
8 ¼	9	R-38 (6.66)	R-30.7 (5.42)	0.033 (0.185)	R-45 (7.93)	R-35.0 (6.17)	0.029 (0.162)	R-54 (9.51)	R-40.0 (7.04)	0.025 (0.142)
10	10 ¾	R-45 (7.95)	R-33.8 (5.96)	0.030 (0.168)	R-54 (9.46)	R-38.3 (6.74)	0.026 (0.148)	R-64 (11.36)	R-43.4 (7.64)	0.023 (0.131)

Detail 10.1.7 | Insulated Standing Seam Roof Supported by Thermal Chairs – Clear Wall

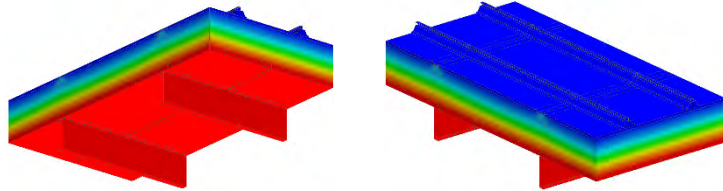

View from Interior

View from Exterior

Thermal Performance Indicators



Assembly 1D (Nominal) R- Value	R_{1D}	R-1.3 (0.23 RSI) + exterior insulation
Transmittance / Resistance	U_o , R_o	“Clear wall” U- and R-value

Scenario

Scenario	Insulation Placement
A	Compressed R-19 batt between and over hat tracks
B	Compressed R-19 batt between and over hat tracks with 1” XPS thermal block
C	Compressed R-19 batt between hat tracks
D	Mineral Wool between hat tracks, no compressed insulation over hat tracks

Nominal (1D) vs. Assembly Performance Indicators

Scenario	Exterior Insulation 1D R-Value (RSI)	R_{1D} ft ² ·hr·°F / Btu (m ² K / W)	R_o ft ² ·hr·°F / Btu (m ² K / W)	U_o Btu/ft ² ·hr·°F (W/m ² K)
A	R-57.6 (10.1)	R-58.9 (10.33)	R-33.4 (5.87)	0.030 (0.170)
B	R-57.6 (10.1)	R-58.9 (10.33)	R-36.4 (6.40)	0.028 (0.156)
C	R-57.6 (10.1)	R-58.9 (10.33)	R-31.7 (5.59)	0.032 (0.179)
D	R-51.2 (9.0)	R-58.9 (10.33)	R-32.4 (5.71)	0.031 (0.175)

Detail 10.1.8 Standing Seam Roof with Draped Insulation – Clear Wall

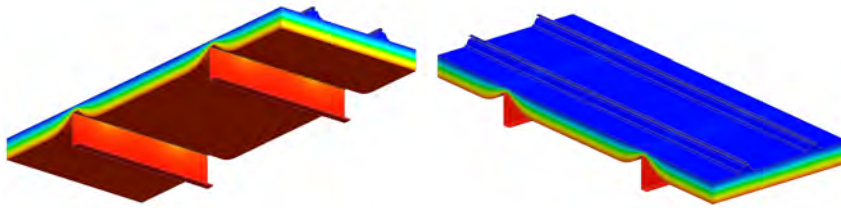

View from Interior

View from Exterior

Thermal Performance Indicators



Assembly 1D (Nominal) R-Value	R_{1D}	R-0.8 (0.14 RSI) + exterior insulation
Transmittance / Resistance	U_o , R_o	“Clear wall” U- and R-value

Nominal (1D) vs. Assembly Performance Indicators

Exterior Insulation 1D R-Value (RSI)	R_{1D} ft ² ·hr·°F / Btu (m ² K / W)	R_o ft ² ·hr·°F / Btu (m ² K / W)	U_o Btu/ft ² ·hr ·°F (W/m ² K)
R-19 (3.35)	R-19.8 (3.49)	R-15.7(2.77)	0.064 (0.361)

Detail 10.1.9

Exterior Insulated Low Sloped Roof (3.4 fasteners/m², 0.3 fasteners/ft²) – Clear Roof Assembly

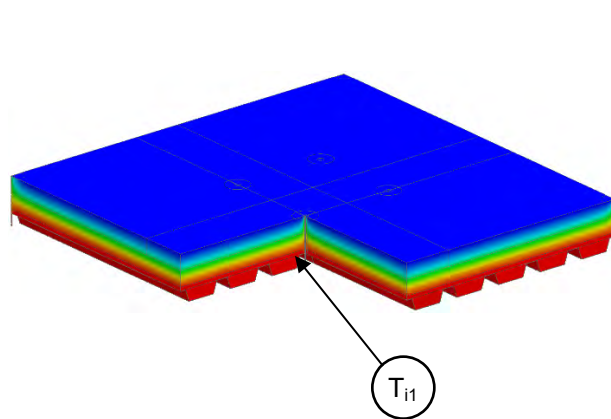

View from Exterior

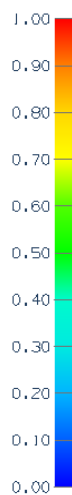

Thermal Performance Indicators

Assembly 1D (Nominal) R-Value	R_{1D}	R-2.6 (0.46 RSI) + Insulation
Transmittance / Resistance without Anomaly	U_o, R_o	“clear wall” U- and R-value, without fastener
Surface Temperature Index ¹	T_i	0 = exterior temperature 1 = interior temperature
Point Transmittance	χ	Incremental increase in transmittance for fasteners

¹Surface temperatures are a result of steady-state conductive heat flow with constant heat transfer coefficients. Limitations are identified in final report.

Scenarios

Scenario	Fastener Arrangement	Fastener Size
A	Fully Fastened	#10
B	Fully Fastened	#14
C	Partially Fastened	#10
D	Partially Fastened	#14
E	Fully Adhered	-
F	Fully Fastened	#14
G	Fully Fastened	#14

Nominal (1D) vs. Assembly Performance Indicators

	Exterior Insulation 1D R-Value (RSI)	R_{1D} ft ² ·hr·°F / Btu (m ² K / W)	R_o ft ² ·hr·°F / Btu (m ² K / W)	U_o Btu/ft ² ·hr·°F (W/m ² K)	R ft ² ·hr·°F / Btu (m ² K / W)	U Btu/ft ² ·hr·°F Hey (W/m ² K)	χ Btu/hr °F (W/K)
A	R-22.8 (4.02)	R-25.4 (4.48)	R-24.8 (4.36)	0.040 (0.23)	R-23.6 (4.16)	0.042 (0.24)	0.006 (0.003)
B	R-22.8 (4.02)	R-25.4 (4.48)	R-24.8 (4.36)	0.040 (0.23)	R-22.4 (3.95)	0.045 (0.25)	0.013 (0.007)
C	R-22.8 (4.02)	R-25.4 (4.48)	R-24.8 (4.36)	0.040 (0.23)	R-24.5 (4.32)	0.041 (0.23)	0.001 (0.001)
D	R-22.8 (4.02)	R-25.4 (4.48)	R-24.8 (4.36)	0.040 (0.23)	R-24.4 (4.30)	0.041 (0.23)	0.002 (0.001)
E	R-22.8 (4.02)	R-25.4 (4.48)	R-24.8 (4.36)	0.040 (0.23)	R-24.8 (4.36)	0.040 (0.23)	-
F	R-28.5 (5.02)	R-31.1 (5.48)	R-30.5 (5.36)	0.033 (0.19)	R-27.3 (4.81)	0.037 (0.21)	0.012 (0.006)
G	R-39.9 (7.03)	R-42.5 (7.49)	R-41.9 (7.37)	0.024 (0.14)	R-36.9 (6.50)	0.027 (0.15)	0.010 (0.005)

Temperature Indices

	A	B	C	D	E	F	G	
T_{i1}	0.95	0.94	0.96	0.96	0.97	0.94	0.96	At fastener penetration through steel deck

Detail 10.1.10

Exterior Insulated Sloped Metal Roof with Bearing Plates 18" x 48" spacing – Clear Roof Assembly

Thermal Performance Indicators

Assembly 1D (Nominal) R-Value	R_{1D}	R-8.3 (1.44 RSI) + Insulation
Transmittance / Resistance without Anomaly	U_o, R_o	"clear wall" U- and R-value, without fastener
Surface Temperature Index ¹	T_i	0 = exterior temperature 1 = interior temperature
Point Transmittance	χ	Incremental increase in transmittance for bearing plate with two fasteners

¹Surface temperatures are a result of steady-state conductive heat flow with constant heat transfer coefficients. Limitations are identified in final report.

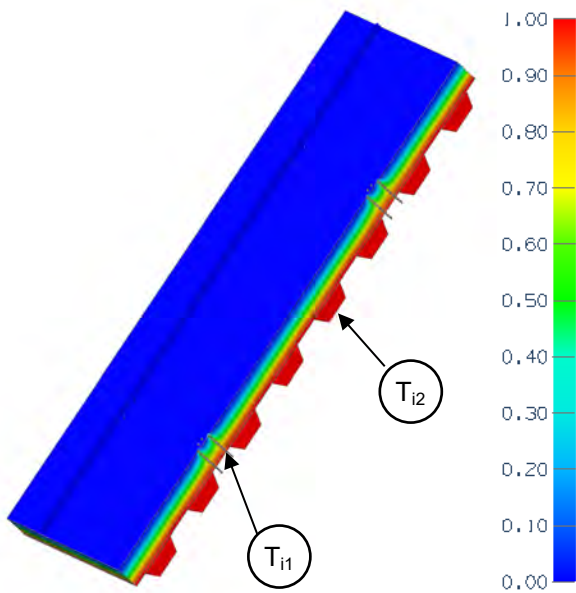

View from Exterior

Nominal (1D) vs. Assembly Performance Indicators

Exterior Insulation 1D R-Value (RSI)	R_{1D} ft ² ·hr·°F / Btu (m ² K / W)	R_o ft ² ·hr·°F / Btu (m ² K / W)	U_o Btu/ft ² ·hr·°F (W/m ² K)	R ft ² ·hr·°F / Btu (m ² K / W)	U Btu/ft ² ·hr·°F (W/m ² K)	χ Btu/hr °F (W/K)
R-22.8 (4.02)	R-31.1 (5.48)	R-28.2 (4.97)	0.035 (0.20)	R-27.3 (4.81)	0.037 (0.21)	0.0074 (0.0039)
R-34.2 (6.02)	R-42.5 (7.49)	R-39.8 (7.00)	0.025 (0.14)	R-37.8 (6.67)	0.026 (0.15)	0.0076 (0.0040)
R-45.6 (8.03)	R-53.9 (9.49)	R-51.1 (9.00)	0.020 (0.11)	R-48.3 (8.50)	0.021 (0.12)	0.0069 (0.0036)

Temperature Indices

	R22.8	R34.2	R45.6	
T_{i1}	0.95	0.96	0.97	Min T on steel deck, at fasteners
T_{i2}	0.97	0.98	0.99	Max T on steel deck, between fasteners

Detail 10.1.11

Exterior Insulated Sloped Metal Roof with High Compressive Strength Mineral Wool Insulation and with Bearing Plates 18" x 48" spacing – Clear Roof Assembly

Thermal Performance Indicators

Assembly 1D (Nominal) R-Value	R_{1D}	R-7.3 (1.27 RSI) + Insulation
Transmittance / Resistance without Anomaly	U_o, R_o	"clear wall" U- and R-value, without fastener
Surface Temperature Index ¹	T_i	0 = exterior temperature 1 = interior temperature
Point Transmittance	χ	Incremental increase in transmittance for bearing plate with two fasteners

¹Surface temperatures are a result of steady-state conductive heat flow with constant heat transfer coefficients. Limitations are identified in final report.

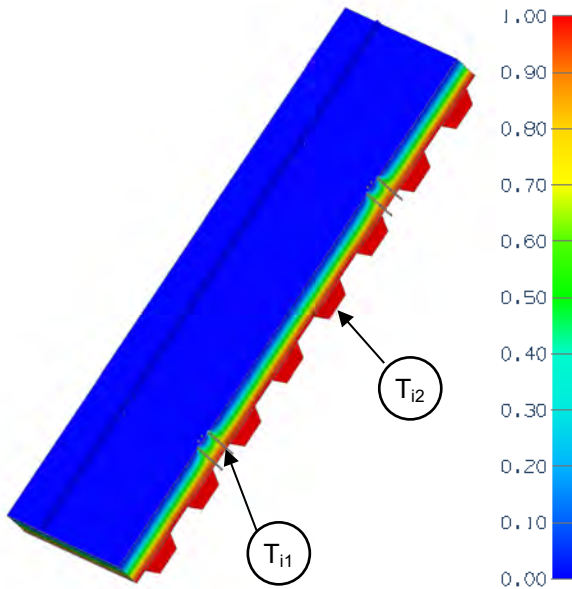

View from Exterior

Nominal (1D) vs. Assembly Performance Indicators

Exterior Insulation 1D R-Value (RSI)	R_{1D} ft ² ·hr·°F / Btu (m ² K / W)	R_o ft ² ·hr·°F / Btu (m ² K / W)	U_o Btu/ft ² ·hr ·°F (W/m ² K)	R ft ² ·hr·°F / Btu (m ² K / W)	U Btu/ft ² ·hr ·°F (W/m ² K)	χ Btu/hr °F (W/K)
R-15.2 (2.68)	R-22.5 (3.96)	R-19.7 (3.47)	0.051 (0.29)	R-19.1 (3.37)	0.052 (0.30)	0.0084 (0.0044)
R-22.8 (4.02)	R-30.1 (5.3)	R-27.4 (4.82)	0.037 (0.21)	R-26.4 (4.64)	0.038 (0.22)	0.0086 (0.0045)
R-30.4 (5.35)	R-37.7 (6.64)	R-34.9 (6.15)	0.029 (0.16)	R-33.5 (5.89)	0.030 (0.17)	0.0077 (0.0040)

Temperature Indices

	R15.2	R22.8	R30.4	
T_{i1}	0.937	0.949	0.955	Min T on steel deck, at fasteners
T_{i2}	0.963	0.973	0.979	Max T on steel deck, between fasteners

Detail 10.1.12 | Ventilated Wood Frame Low Sloped Roof – Clear Roof Assembly

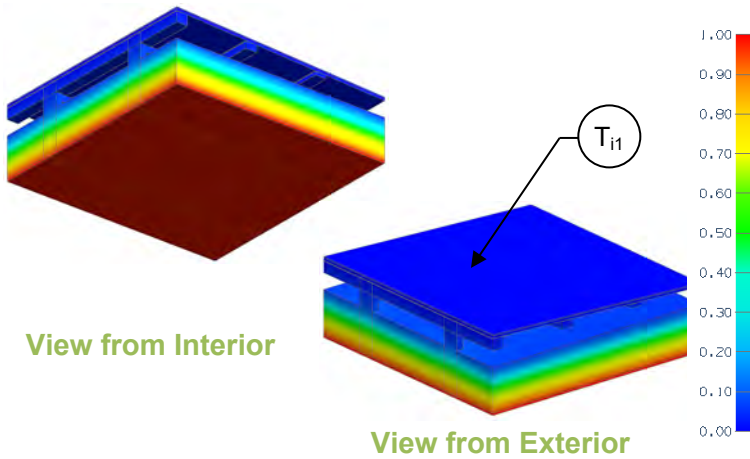

Thermal Performance Indicators

Assembly 1D (Nominal) R-Value	R_{1D}	R-3.1 (0.54 RSI) + roof insulation
Transmittance / Resistance	U_o, R_o	"clear field" U- and R-value
Surface Temperature Index ¹	T_i	0 = exterior temperature 1 = interior temperature

¹Surface temperatures are a result of steady-state conductive heat flow with constant heat transfer coefficients. Limitations are identified in final report.

Nominal (1D) vs. Assembly Performance Indicators

Roof Insulation 1D R-Value (RSI)	R_{1D} ft ² ·hr·°F / Btu (m ² K / W)	R_o ft ² ·hr·°F / Btu (m ² K / W)	U_o Btu/ft ² ·hr ·°F (W/m ² K)
R-20.0 (3.52)	R-23.1 (4.06)	R-22.1 (3.89)	0.045 (0.26)
R-30.0 (5.28)	R-33.1 (5.83)	R-31.8 (5.59)	0.031 (0.18)
R-40.0 (7.04)	R-43.1 (7.59)	R-40.9 (7.20)	0.024 (0.14)

Temperature Indices

	R20	R30	R40	
T_{it}	0.05	0.03	0.03	Min T on roof sheathing, between joists above wood truss

Detail 10.1.13

Exterior Insulated Low Sloped Roof (10.8 fasteners/m², 1 fasteners/ft²)– Clear Roof Assembly

Thermal Performance Indicators

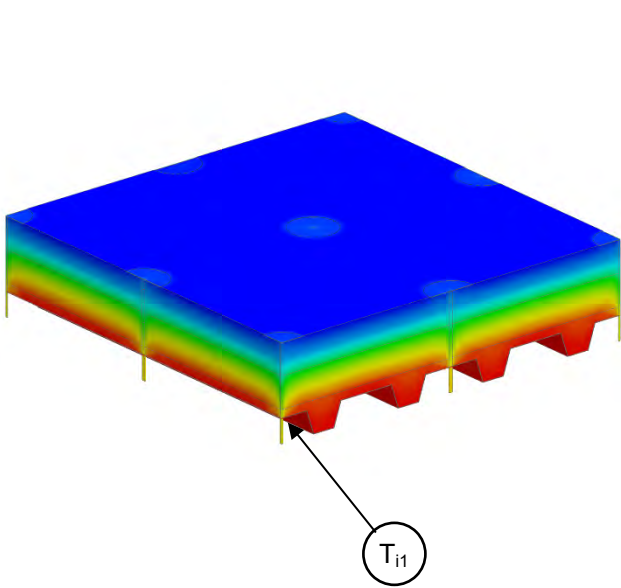

Assembly 1D (Nominal) R-Value	R_{1D}	R-2.6 (0.46 RSI) + Insulation
Transmittance / Resistance without Anomaly	U_o, R_o	“clear wall” U- and R-value, without fastener
Surface Temperature Index ¹	T_i	0 = exterior temperature 1 = interior temperature
Point Transmittance	χ	Incremental increase in transmittance for fasteners

¹Surface temperatures are a result of steady-state conductive heat flow with constant heat transfer coefficients. Limitations are identified in final report.

View from Exterior

Nominal (1D) vs. Assembly Performance Indicators

Exterior Insulation 1D R-Value (RSI)	R_{1D} ft ² ·hr·°F / Btu (m ² K / W)	R_o ft ² ·hr·°F / Btu (m ² K / W)	U_o Btu/ft ² ·hr ·°F (W/m ² K)	R ft ² ·hr·°F / Btu (m ² K / W)	U Btu/ft ² ·hr ·°F (W/m ² K)	χ Btu/hr °F (W/K)
R-22.8 (4.02)	R-25.8 (4.55)	R-24.8 (4.36)	0.040 (0.23)	R-18.0 (3.18)	0.055 (0.31)	0.015 (0.008)
R-28.5 (5.02)	R-31.5 (5.55)	R-30.5 (5.36)	0.033 (0.19)	R-21.6 (3.80)	0.046 (0.26)	0.013 (0.007)
R-39.9 (7.03)	R-42.9 (7.56)	R-41.9 (7.37)	0.024 (0.14)	R-28.6 (5.04)	0.035 (0.20)	0.011 (0.006)

Temperature Indices

	R22.8	R28.5	R39.9	
T_{i1}	0.92	0.93	0.94	At fastener penetration through steel deck

Detail 10.1.14 | Sloped Wood Framed Roof with Insulation at Ceiling

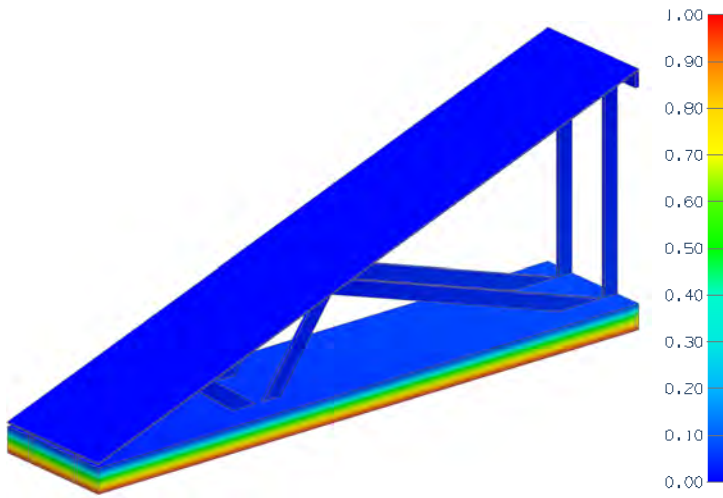

View from Exterior

Thermal Performance Indicators

Assembly 1D (Nominal) R-Value	R_{1D}	R-3.4 (0.60 RSI) + roof insulation
Transmittance / Resistance	U_o, R_o	“clear roof” U- and R-value

Nominal (1D) vs. Assembly Performance Indicators

Roof Insulation 1D R-Value (RSI)	R_{1D} ft ² ·hr·°F / Btu (m ² K / W)	R_o ft ² ·hr·°F / Btu (m ² K / W)	U_o Btu/ft ² ·hr ·°F (W/m ² K)
R-30 (5.28)	R-33.4 (5.88)	R-31.5 (5.55)	0.032 (0.18)

Detail 10.1.15 | Sloped Wood Framed Roof with Insulation at Roof Sheathing

Thermal Performance Indicators

Assembly 1D (Nominal) R-Value	R_{1D}	R-3.4 (0.60 RSI) + roof insulation
Transmittance / Resistance	U_o , R_o	"clear roof" U- and R-value

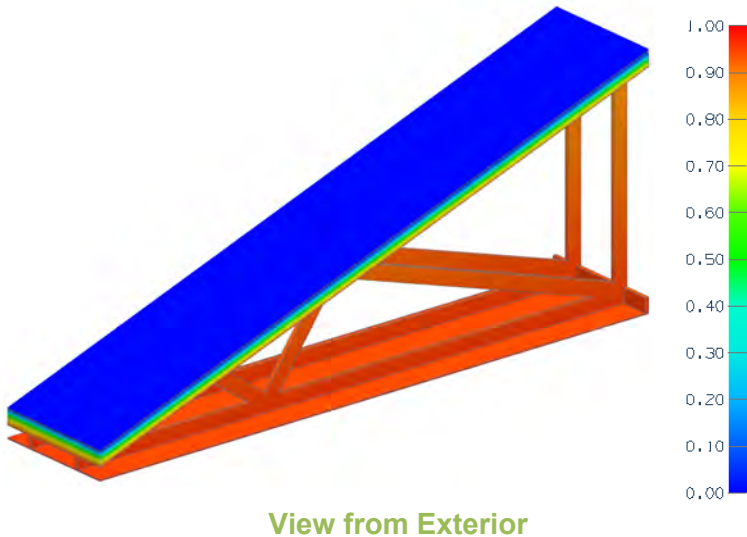

Nominal (1D) vs. Assembly Performance Indicators

Roof Insulation 1D R-Value (RSI)	R_{1D} ft ² ·hr·°F / Btu (m ² K / W)	R_o ft ² ·hr·°F / Btu (m ² K / W)	U_o Btu/ft ² ·hr ·°F (W/m ² K)
R-30 (5.28)	R-33.4 (5.88)	R-27.0 (4.76)	0.037 (0.21)

Detail 10.1.16

Exterior Insulated Low Sloped Roof with Fully Adhered Roof Membrane and Mineral Wool Insulation – Clear Roof Assembly

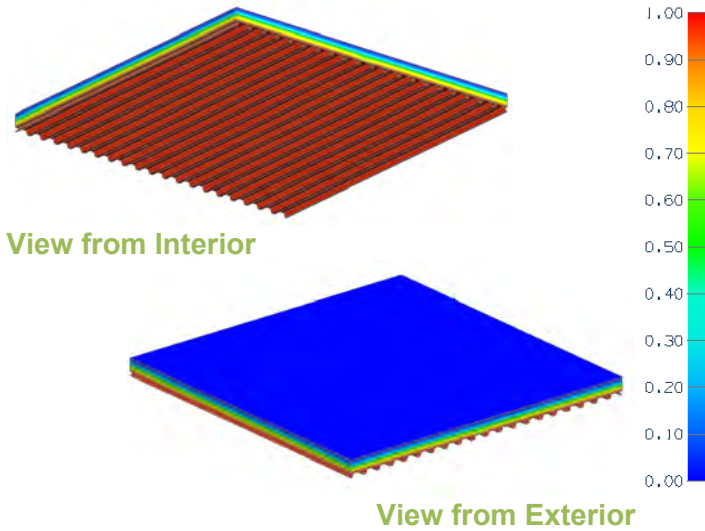

Thermal Performance Indicators

Assembly 1D (Nominal) R-Value	R_{1D}	R-3.5 (0.62 RSI) + Insulation
Transmittance / Resistance	U_o, R_o	“clear wall” U- and R-value
Surface Temperature Index ¹	T_i	0 = exterior temperature 1 = interior temperature

¹Surface temperatures are a result of steady-state conductive heat flow with constant heat transfer coefficients. Limitations are identified in final report.

Nominal (1D) vs. Assembly Performance Indicators

Bottom Layer Roof Insulation 1D R-Value (RSI)	Top Layer Roof Insulation 1D R-Value (RSI)	R_{1D} ft ² ·hr·°F / Btu (m ² K / W)	R_o ft ² ·hr·°F / Btu (m ² K / W)	U_o Btu/ft ² ·hr ·°F (W/m ² K)
R-9.9 (1.74)	R-9.9 (1.74)	R-23.4 (4.12)	R-22.7 (3.99)	0.044 (0.25)
R-19.9 (3.50)	R-9.9 (1.74)	R-33.4 (5.88)	R-32.6 (5.74)	0.031 (0.17)
R-29.8 (5.25)	R-9.9 (1.74)	R-43.3 (7.63)	R-42.5 (7.49)	0.024 (0.13)
R-39.8 (7.01)	R-9.9 (1.74)	R-53.3 (9.39)	R-52.5 (9.24)	0.019 (0.11)

Detail 10.1.17

Exterior Insulated Low Sloped Roof with Fully Adhered Roof Membrane and Mineral Wool and Polyisocyanurate Insulation – Clear Roof Assembly

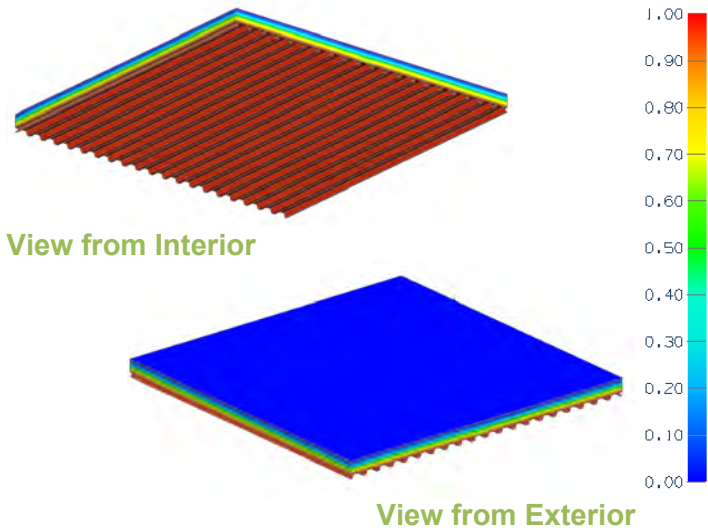

Thermal Performance Indicators

Assembly 1D (Nominal) R-Value	R_{1D}	R-3.5 (0.62 RSI) + Insulation
Transmittance / Resistance	U_o, R_o	“clear wall” U- and R-value
Surface Temperature Index ¹	T_i	0 = exterior temperature 1 = interior temperature

¹Surface temperatures are a result of steady-state conductive heat flow with constant heat transfer coefficients. Limitations are identified in final report.

Nominal (1D) vs. Assembly Performance Indicators

Bottom Layer Roof Insulation 1D R-Value (RSI)	Top Layer Roof Insulation 1D R-Value (RSI)	R_{1D} ft ² ·hr·°F / Btu (m ² K / W)	R_o ft ² ·hr·°F / Btu (m ² K / W)	U_o Btu/ft ² ·hr ·°F (W/m ² K)
R-11.4 (2.01)	R-9.9 (1.74)	R-24.9 (4.38)	R-24.1 (4.25)	0.041 (0.24)
R-22.8 (4.02)	R-9.9 (1.74)	R-36.3 (6.39)	R-35.5 (6.26)	0.028 (0.16)
R-34.2 (6.02)	R-9.9 (1.74)	R-47.7 (8.40)	R-46.9 (8.27)	0.021 (0.12)
R-45.6 (8.03)	R-9.9 (1.74)	R-59.1 (10.41)	R-58.3 (10.27)	0.017 (0.10)

Detail 10.2.1

Exterior Insulated Sloped Metal Roof with Metal Sub-Girts (24" o.c.) Supporting Metal Roof – Ridge Intersection

Thermal Performance Indicators

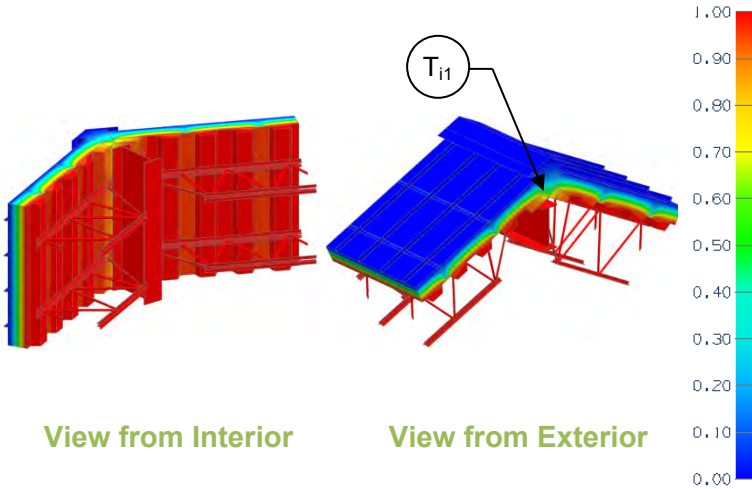

Assembly 1D (Nominal) R-Value	R_{1D}	R-3.0 (0.53 RSI) + exterior insulation
Transmittance / Resistance without Anomaly	U_o, R_o	“clear field” U- and R-value, without ridge (Detail 6.2)
Transmittance / Resistance	U, R	U and R-values for the assembly
Surface Temperature Index ¹	T_i	0 = exterior temperature 1 = interior temperature
Linear Transmittance	ψ	Incremental increase in transmittance per linear length of ridge

¹Surface temperatures are a result of steady-state conductive heat flow with constant heat transfer coefficients. Limitations are identified in final report.

Nominal (1D) vs. Assembly Performance Indicators

Exterior Insulation 1D R-Value (RSI)	R_{1D} ft ² ·hr·°F / Btu (m ² K / W)	R_o ft ² ·hr·°F / Btu (m ² K / W)	U_o Btu/ft ² ·hr·°F (W/m ² K)	R ft ² ·hr·°F / Btu (m ² K / W)	U Btu/ft ² ·hr·°F (W/m ² K)	ψ Btu/ft·hr·°F (W/m K)
R-20 (3.52)	R-23 (4.05)	R-10.6 (1.87)	0.094 (0.53)	R-8.3 (1.46)	0.121 (0.69)	0.279 (0.483)
R-30 (5.28)	R-33 (5.81)	R-12.8 (2.25)	0.078 (0.44)	R-9.6 (1.69)	0.104 (0.59)	0.272 (0.471)

Temperature Indices

	R20	R30	
T_{i1}	0.48	0.51	Min T on sheathing, along ridge

Detail 10.2.2

Insulated Concrete Slab – Concrete Curb or Wall Intersection

Thermal Performance Indicators

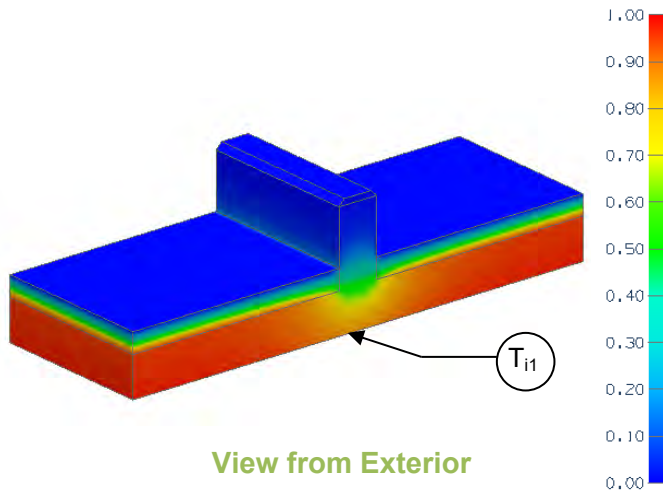

Assembly 1D (Nominal) R-Value	R_{1D}	R-1.9 (0.33 RSI) + Insulation
Transmittance / Resistance without Anomaly	U_o, R_o	“clear field” U- and R-value, without concrete anomaly
Surface Temperature Index ¹	T_i	0 = exterior temperature 1 = interior temperature
Linear Transmittance	ψ	Incremental increase in transmittance per linear length of concrete anomaly

¹Surface temperatures are a result of steady-state conductive heat flow with constant heat transfer coefficients. Limitations are identified in final report.

Nominal (1D) vs. Assembly Performance Indicators

Base Assembly – Roof

Exterior Insulation 1D R-Value (RSI)	R_{1D} ft ² ·hr·°F / Btu (m ² K / W)	R_o ft ² ·hr·°F / Btu (m ² K / W)	U_o Btu/ft ² ·hr·°F (W/m ² K)
R-20 (3.52)	R-21.9 (3.86)	R-21.9 (3.86)	0.046 (0.26)

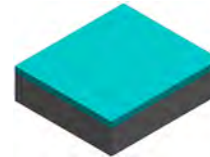

Concrete Anomaly Linear Transmittance

R ft ² ·hr·°F / Btu (m ² K / W)	U Btu/ft ² ·hr·°F (W/m ² K)	ψ Btu/ft hr °F (W/m K)
R-8.8 (1.54)	0.114 (0.65)	0.536 (0.927)

Temperature Indices

T_{i1}	0.82	Min T on concrete, at center of anomaly
----------	------	---

Detail 10.2.3

Owens Corning Insulated Projected Membrane Roof – Floating Concrete Wall Intersection

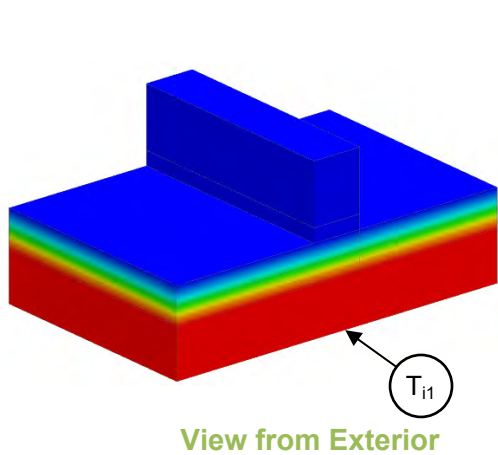

Thermal Performance Indicators

Assembly 1D (Nominal) R-Value	R_{1D}	R-1.9 (0.33 RSI) + exterior insulation
Transmittance / Resistance without Anomaly	U_o, R_o	“clear wall” U- and R-value, without concrete anomaly
Transmittance / Resistance	U, R	U and R-values for the assembly
Surface Temperature Index ¹	T_i	0 = exterior temperature 1 = interior temperature
Linear Transmittance	ψ	Incremental increase in transmittance per linear length of concrete anomaly

¹Surface temperatures are a result of steady-state conductive heat flow with constant heat transfer coefficients. Limitations are identified in final report.

Nominal (1D) vs. Assembly Performance Indicators

Base Assembly - Roof

Exterior Insulation 1D R-Value (RSI)	R_{1D} ft ² ·hr·°F / Btu (m ² K / W)	R_o ft ² ·hr·°F / Btu (m ² K / W)	U_o Btu/ft ² ·hr ·°F (W/m ² K)
R-20 (3.52)	R-21.9 (3.86)	R-21.9 (3.86)	0.046 (0.26)
R-30 (5.28)	R-31.9 (5.62)	R-31.9 (5.62)	0.031 (0.18)
R-40 (7.04)	R-41.9 (7.39)	R-41.9 (7.38)	0.024 (0.14)

Concrete Anomaly Linear Transmittance

R ft ² ·hr·°F / Btu (m ² K / W)	U Btu/ft ² ·hr ·°F (W/m ² K)	ψ Btu/ft ·hr ·°F (W/m K)
R-21.9 (3.86)	0.046 (0.26)	0 (0)
R-31.9 (5.62)	0.031 (0.18)	0 (0)
R-41.9 (7.38)	0.024 (0.14)	0 (0)

Temperature Indices

T_{i1}	0.97	Min T on concrete, at center of anomaly
----------	------	---

Detail 10.2.4

Exterior Insulated Sloped Metal Roof with Metal Sub-Girts (24" o.c.) Supporting Standing Seam Metal Roof and Curtain Wall – Roof to Wall Intersection with Through Wall Structural Beam and Continuous Through Wall Structural Metal Deck

Thermal Performance Indicators

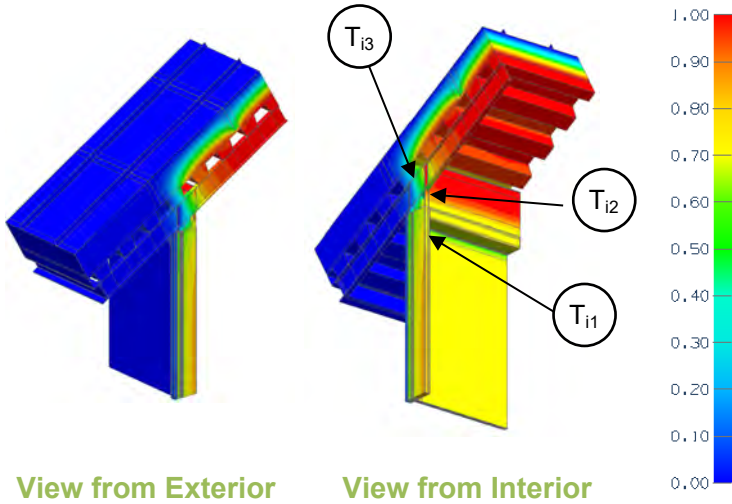

Assembly 1D (Nominal) R-Value	R_{1D}	R-2.5 (0.44 RSI) + exterior insulation
Transmittance / Resistance without Anomaly	U_o, R_o, U_g	“clear field” U- and R-value: o = without curtainwall g = glazing
Transmittance / Resistance	U, R	U and R-values for the combined assembly
Surface Temperature Index ¹	T_i	0 = exterior temperature 1 = interior temperature
Linear Transmittance	ψ	Incremental increase in transmittance per linear length of curtainwall

¹Surface temperatures are a result of steady-state conductive heat flow with constant heat transfer coefficients. Limitations are identified in final report.

Nominal (1D) vs. Assembly Performance Indicators

Base Assembly Roof

Roof Insulation 1D R-Value (RSI)	R_{1D} ft ² ·hr·°F / Btu (m ² K / W)	R_o ft ² ·hr·°F / Btu (m ² K / W)	U_o Btu/ft ² ·hr ·°F (W/m ² K)
R-36 (6.34)	R-38.5 (6.78)	12.4 (2.18)	0.081 (0.46)

Base Assembly Glazing

$U_{\text{centre of glass}}$ Btu/ft ² ·hr ·°F (W/m ² K)	U_g Btu/ft ² ·hr ·°F (W/m ² K)
0.321 (1.82)	0.344 (1.95)

Roof to Wall Linear Transmittance

R ft ² ·hr·°F / Btu (m ² K / W)	U Btu/ft ² ·hr ·°F (W/m ² K)	ψ Btu/ft ² ·hr ·°F (W/m ² K)
2.7 (0.48)	0.369 (2.10)	0.679 (1.177)

Temperature Indices

T_{i1}	0.53	Upper corner of glazing
T_{i2}	0.54	Beam at curtain wall interior closure panel
T_{i3}	0.35	Underside of roof deck at beam

Detail 10.2.5

Exterior Insulated Sloped Metal Roof with Metal Sub-Girts (24" o.c.) Supporting Standing Seam Metal Roof and Curtain Wall – Roof to Wall Intersection with Through Wall Structural Beam and Thermally Broken Structural Metal Deck

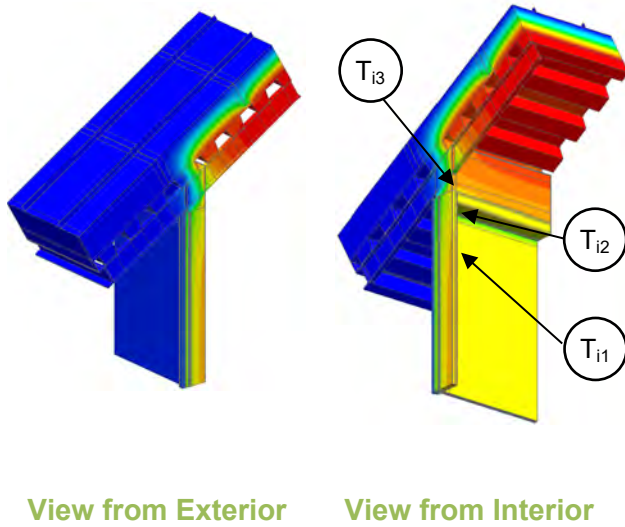

View from Exterior

View from Interior

Thermal Performance Indicators

Assembly 1D (Nominal) R-Value	R_{1D}	R-2.5 (0.44 RSI) + exterior insulation
Transmittance / Resistance without Anomaly	U_o, R_o, U_g	"clear field" U- and R-value: o = without curtainwall g = glazing
Transmittance / Resistance	U, R	U and R-values for the combined assembly
Surface Temperature Index ¹	T_i	0 = exterior temperature 1 = interior temperature
Linear Transmittance	ψ	Incremental increase in transmittance per linear length of curtainwall

¹Surface temperatures are a result of steady-state conductive heat flow with constant heat transfer coefficients. Limitations are identified in final report.

Nominal (1D) vs. Assembly Performance Indicators

Base Assembly Roof

Roof Insulation 1D R-Value (RSI)	R_{1D} ft ² ·hr·°F / Btu (m ² K / W)	R_o ft ² ·hr·°F / Btu (m ² K / W)	U_o Btu/ft ² ·hr·°F (W/m ² K)
R-36 (6.34)	R-38.5 (6.78)	12.4 (2.18)	0.081 (0.46)

Base Assembly Glazing

$U_{\text{centre of glass}}$ Btu/ft ² ·hr·°F (W/m ² K)	U_g Btu/ft ² ·hr·°F (W/m ² K)
0.321 (1.82)	0.344 (1.95)

Roof to Wall Linear Transmittance

R ft ² ·hr·°F / Btu (m ² K / W)	U Btu/ft ² ·hr·°F (W/m ² K)	ψ Btu/ft·hr·°F (W/m K)
3.2 (0.56)	0.317 (1.80)	0.350 (0.607)

Temperature Indices

T_{i1}	0.53	Upper corner of glazing
T_{i2}	0.53	Beam at curtain wall interior closure panel
T_{i3}	0.80	Underside of roof deck at beam

Detail 10.2.6

Exterior Insulated Sloped Metal Roof with Metal Sub-Girts (24" o.c.) Supporting Standing Seam Metal Roof and Curtain Wall – Roof to Wall Intersection with Through Wall Structural Beam and Fully Insulated Soffit

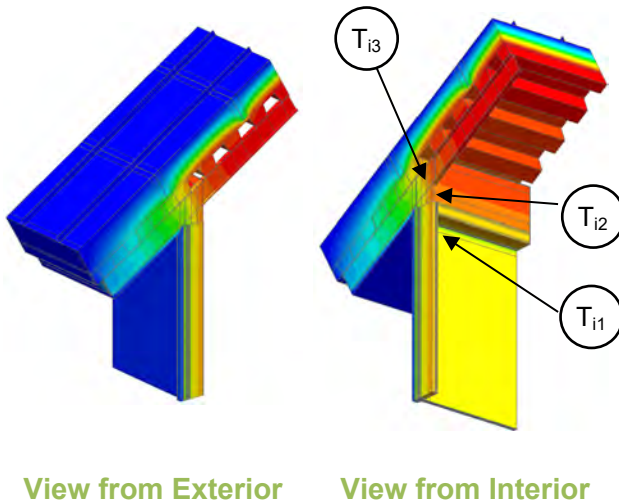

Thermal Performance Indicators

Assembly 1D (Nominal) R-Value	R_{1D}	R-2.5 (0.44 RSI) + exterior insulation
Transmittance / Resistance without Anomaly	U_o, R_o, U_g	"clear field" U- and R-value: o = without curtainwall g = glazing
Transmittance / Resistance	U, R	U and R-values for the combined assembly
Surface Temperature Index ¹	T_i	0 = exterior temperature 1 = interior temperature
Linear Transmittance	ψ	Incremental increase in transmittance per linear length of curtainwall

¹Surface temperatures are a result of steady-state conductive heat flow with constant heat transfer coefficients. Limitations are identified in final report.

Nominal (1D) vs. Assembly Performance Indicators

Base Assembly Roof

Roof Insulation 1D R-Value (RSI)	R_{1D} ft ² ·hr·°F / Btu (m ² K / W)	R_o ft ² ·hr·°F / Btu (m ² K / W)	U_o Btu/ft ² ·hr ·°F (W/m ² K)
R-36 (6.34)	R-38.5 (6.78)	12.4 (2.18)	0.081 (0.46)

Base Assembly Glazing

$U_{\text{centre of glass}}$ Btu/ft ² ·hr ·°F (W/m ² K)	U_g Btu/ft ² ·hr ·°F (W/m ² K)
0.321 (1.82)	0.344 (1.95)

Roof to Wall Linear Transmittance

R ft ² ·hr·°F / Btu (m ² K / W)	U Btu/ft ² ·hr ·°F (W/m ² K)	ψ Btu/ft ·hr ·°F (W/m K)
3.1 (0.55)	0.318 (1.81)	0.365 (0.633)

Temperature Indices

T_{i1}	0.58	Upper corner of glazing
T_{i2}	0.82	Beam at curtain wall interior closure panel
T_{i3}	0.71	Underside of roof deck at beam

Detail 10.2.7

Aluminum Framed Double Glazed Skylight – Exterior Insulated Concrete Curb Intersection

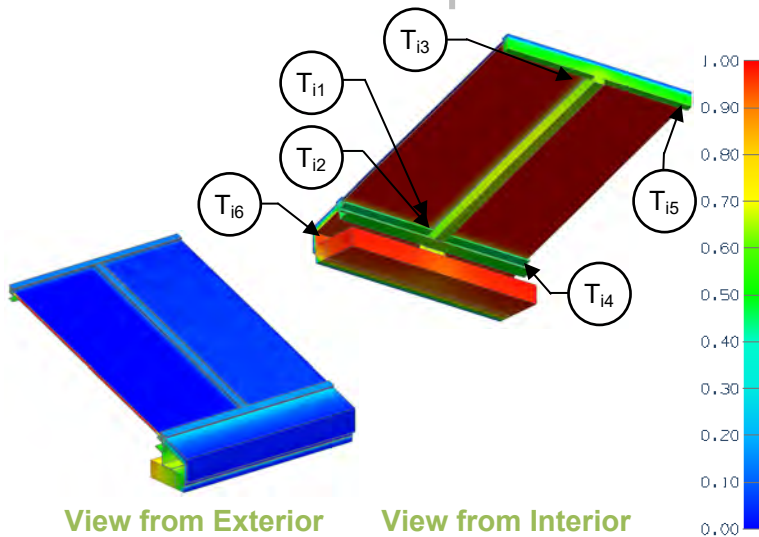

Thermal Performance Indicators

Transmittance / Resistance	U_{cog}, U_f	U-value for cog = center of glass f = framing
Transmittance / Resistance	U, R	U and R-values for the overall assembly
Surface Temperature Index ¹	T_i	0 = exterior temperature 1 = interior temperature

¹Surface temperatures are a result of steady-state conductive heat flow with constant heat transfer coefficients. Limitations are identified in final report.

Nominal (1D) vs. Assembly Performance Indicators

U_{cog} Btu/ h ft ² °F (W/m ² K)	U_{f_Ridge} ft ² ·hr·°F / Btu (m ² K / W)	U_{f_Eaves} ft ² ·hr·°F / Btu (m ² K / W)	U_{f_Rafter} ft ² ·hr·°F / Btu (m ² K / W)	R ft ² ·hr·°F / Btu (m ² K / W)	U Btu/ft ² ·hr ·°F (W/m ² K)
0.234 (1.33)	1.81 (10.30)	2.06 (11.69)	1.28 (7.27)	R-2.7 (0.48)	0.369 (2.10)

Temperature Indices

T_{i1}	0.67	At corner of glass, 30 mm away from glass edge
T_{i2}	0.52	At edge of glass of eaves, at rafter
T_{i3}	0.53	At edge of glass of ridge purlin, at rafter
T_{i4}	0.44	At eaves purlin, centre of skylight
T_{i5}	0.50	At ridge purlin, centre of skylight
T_{i6}	0.85	At drainage flashing, centre of skylight

Detail 10.3.1 | Exterior Insulated Conventional Flat Roof – Roof Anchor

Thermal Performance Indicators

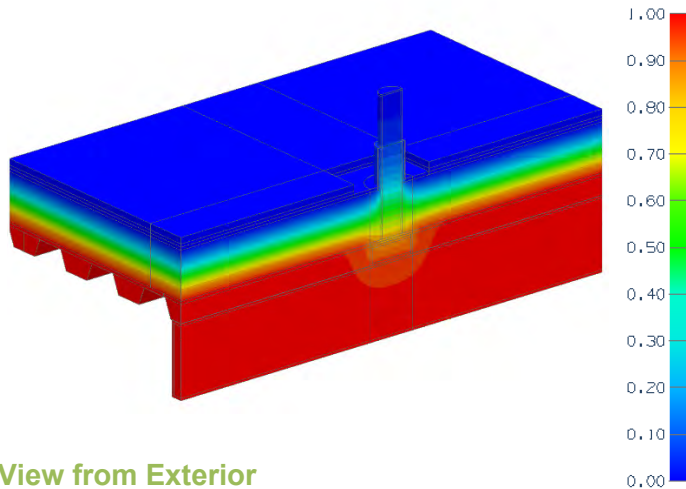

Assembly 1D (Nominal) R-Value	R_{1D}	R-2.7 (0.48 RSI) + insulation
Transmittance / Resistance without Anomaly	U_o, R_o	“clear field” U- and R-value, without roof anchor
Surface Temperature Index ¹	T_i	0 = exterior temperature 1 = interior temperature
Point Transmittance	χ	Incremental increase in transmittance for anchor

¹Surface temperatures are a result of steady-state conductive heat flow with constant heat transfer coefficients. Limitations are identified in final report

Nominal (1D) vs. Assembly Performance Indicators

Base Assembly – Roof

Roof Insulation 1D R-Value (RSI)	R_{1D} ft ² ·hr·°F / Btu (m ² K / W)	R_o ft ² ·hr·°F / Btu (m ² K / W)	U_o Btu/ft ² ·hr ·°F (W/m ² K)
R-40 (7.04)	R-42.7 (7.53)	R-42.7 (7.53)	0.023 (0.133)

Roof Anchor Point Transmittance

R ft ² ·hr·°F / Btu (m ² K / W)	U Btu/ft ² ·hr ·°F (W/m ² K)	χ Btu/hr·°F (W/K)
R-26.0 (4.57)	0.039 (0.219)	0.640 (0.34)

Detail 10.3.2

Exterior Insulated Conventional Flat Roof – Armatherm Thermal Break under Roof Anchor

Thermal Performance Indicators

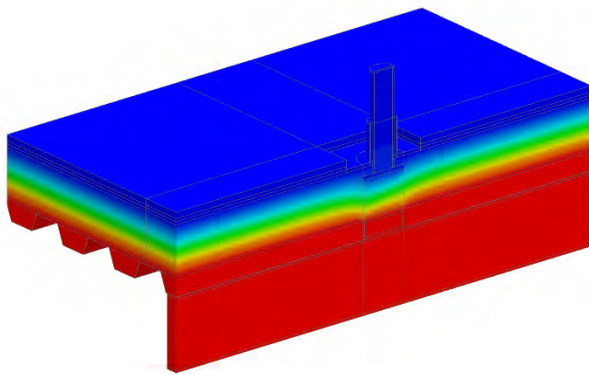

View from Exterior



Assembly 1D (Nominal) R-Value	R_{1D}	R-2.7 (0.48 RSI) + insulation
Transmittance / Resistance without Anomaly	U_o, R_o	“clear field” U- and R-value, without roof anchor
Surface Temperature Index ¹	T_i	0 = exterior temperature 1 = interior temperature
Point Transmittance	χ	Incremental increase in transmittance for anchor

¹Surface temperatures are a result of steady-state conductive heat flow with constant heat transfer coefficients. Limitations are identified in final report

Scenarios

Scenario	Roof Anchor Arrangement
A	1/2" Armatherm FRR thermal break under roof anchor
B	6" Armatherm 500 thermal break under roof anchor

Nominal (1D) vs. Assembly Performance Indicators

Base Assembly – Roof

Roof Insulation 1D R-Value (RSI)	R_{1D} ft ² ·hr·°F / Btu (m ² K / W)	R_o ft ² ·hr·°F / Btu (m ² K / W)	U_o Btu/ft ² ·hr·°F (W/m ² K)
R-40 (7.04)	R-42.7 (7.53)	R-42.7 (7.53)	0.023 (0.133)

Roof Anchor Point Transmittance

Scenario	R ft ² ·hr·°F / Btu (m ² K / W)	U Btu/ft ² ·hr·°F (W/m ² K)	χ Btu/hr·°F (W/K)
A	R-27.6 (4.86)	0.036 (0.206)	0.542 (0.29)
B	R-37.5 (6.60)	0.027 (0.151)	0.130 (0.07)

Detail 10.3.3

Exterior Insulated Conventional Low-Sloped Roof – Roof Anchor

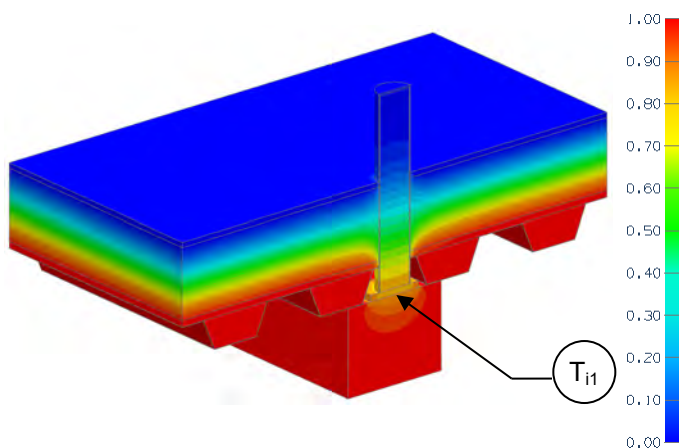

Thermal Performance Indicators

Assembly 1D (Nominal) R-Value	R_{1D}	R-2.28 (0.40 RSI) + insulation
Transmittance / Resistance without Anomaly	U_o, R_o	“clear field” U- and R-value, without connectors or joint
Transmittance / Resistance	U, R	U- and R-values for the overall assembly
Point Transmittance	χ	Incremental increase in transmittance per connector

Scenarios

Scenario	Roof Anchor
A	Without fill insulation
B	With fill insulation

Nominal (1D) vs. Assembly Performance Indicators

Base Assembly – Roof

Roof Insulation 1D R-Value (RSI)	R_{1D} ft ² ·hr·°F / Btu (m ² K / W)	R_o ft ² ·hr·°F / Btu (m ² K / W)	U_o Btu/ft ² ·hr·°F (W/m ² K)
R-34.3 (6.03)	R-36.5 (6.44)	R-36.6 (6.45)	0.027 (0.155)

Roof Anchor Point Transmittance

Scenario	R ft ² ·hr·°F / Btu (m ² K / W)	U Btu/ft ² ·hr·°F (W/m ² K)	χ Btu/hr·°F (W/K)
A	R-25.1 (4.41)	0.040 (0.227)	0.202 (0.106)
B	R-26.7 (4.70)	0.037 (0.213)	0.163 (0.086)

Temperature Indices

	A	B	
T_{i1}	0.80	0.84	Min T on beam, at anchor

Detail 10.3.4

Exterior Insulated Conventional Low-Sloped Roof – Thermal Break in Roof Anchor

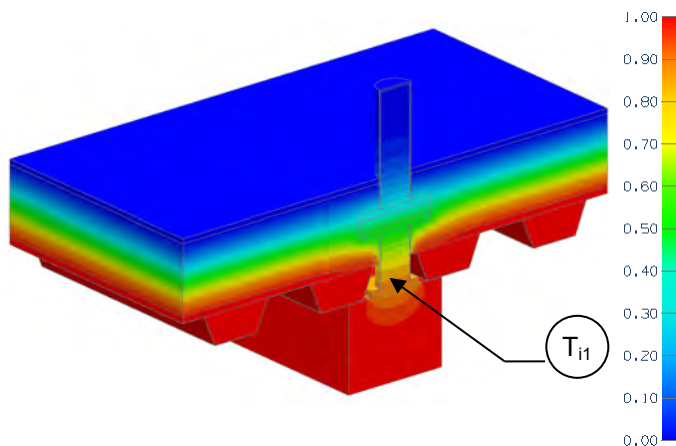

Thermal Performance Indicators

Assembly 1D (Nominal) R-Value	R_{1D}	R-2.28 (0.40 RSI) + insulation
Transmittance / Resistance without Anomaly	U_o, R_o	“clear field” U- and R-value, without connectors or joint
Transmittance / Resistance	U, R	U- and R-values for the overall assembly
Point Transmittance	χ	Incremental increase in transmittance for connector

Scenarios

Scenario	Roof Anchor
A	Without fill insulation
B	With fill insulation above thermal break

Nominal (1D) vs. Assembly Performance Indicators

Base Assembly – Roof

Roof Insulation 1D R-Value (RSI)	R_{1D} ft ² ·hr·°F / Btu (m ² K / W)	R_o ft ² ·hr·°F / Btu (m ² K / W)	U_o Btu/ft ² ·hr ·°F (W/m ² K)
R-34.3 (6.03)	R-36.5 (6.44)	R-36.7 (6.47)	0.027 (0.155)

Roof Anchor Point Transmittance

Scenario	R ft ² ·hr·°F / Btu (m ² K / W)	U Btu/ft ² ·hr ·°F (W/m ² K)	χ Btu/hr·°F (W/K)
A	R-25.8 (4.55)	0.039 (0.220)	0.184 (0.097)
B	R-26.2 (4.61)	0.038 (0.217)	0.175 (0.093)

Temperature Indices

	A	B	
T_{i1}	0.82	0.83	Min T on beam, at anchor

Detail 10.4.1

Exterior Insulated Low Sloped Roof with Fully Adhered Roof Membrane and Mineral Wool Insulation - Flange-Style Drain Penetration

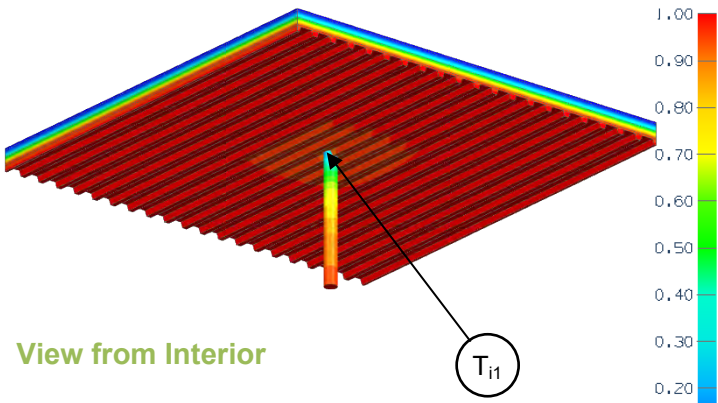

View from Interior

Thermal Performance Indicators

Assembly 1D (Nominal) R-Value	R_{1D}	R-3.5 (0.62 RSI) + Insulation
Transmittance / Resistance without Anomaly	U_o, R_o	"clear field" U- and R-value, without roof drain
Transmittance / Resistance	U, R	U- and R-values for the overall assembly
Surface Temperature Index ¹	T_i	0 = exterior temperature 1 = interior temperature
Point Transmittance	χ	Incremental increase in transmittance for drain

¹Surface temperatures are a result of steady-state conductive heat flow with constant heat transfer coefficients. Limitations are identified in final report.

Nominal (1D) vs. Assembly Performance Indicators

Base Assembly – Roof

Bottom Layer Roof Insulation 1D R-Value (RSI)	Top Layer Roof Insulation 1D R-Value (RSI)	R_{1D} ft ² ·hr·°F / Btu (m ² K / W)	R_o ft ² ·hr·°F / Btu (m ² K / W)	U_o Btu/ft ² ·hr ·°F (W/m ² K)
R-9.9 (1.74)	R-9.9 (1.74)	R-23.4 (4.12)	R-22.7 (3.99)	0.044 (0.25)
R-19.9 (3.50)	R-9.9 (1.74)	R-33.4 (5.88)	R-32.6 (5.74)	0.031 (0.17)
R-29.8 (5.25)	R-9.9 (1.74)	R-43.3 (7.63)	R-42.5 (7.49)	0.024 (0.13)
R-39.8 (7.01)	R-9.9 (1.74)	R-53.3 (9.39)	R-52.5 (9.24)	0.019 (0.11)

Roof Drain Point Transmittance

R ft ² ·hr·°F / Btu (m ² K / W)	U Btu/ft ² ·hr ·°F (W/m ² K)	χ Btu/hr °F (W/K)
R-17.8 (3.13)	0.056 (0.32)	1.208 (0.637)
R-25.3 (4.46)	0.039 (0.22)	0.878 (0.463)
R-32.4 (5.71)	0.031 (0.18)	0.736 (0.388)
R-39.2 (6.90)	0.026 (0.14)	0.648 (0.342)

Temperature Indices

	R-9.9 + R-9.9	R-19.9 + R-9.9	R-29.8 + R-9.9	R-39.8 + R-9.9	
T_{i1}	0.242	0.319	0.383	0.436	Drain penetration at steel deck

Detail 10.4.2

Exterior Insulated Low Sloped Roof with Fully Adhered Roof Membrane and Mineral Wool and Polyisocyanurate Insulation - Flange-Style Drain Penetration

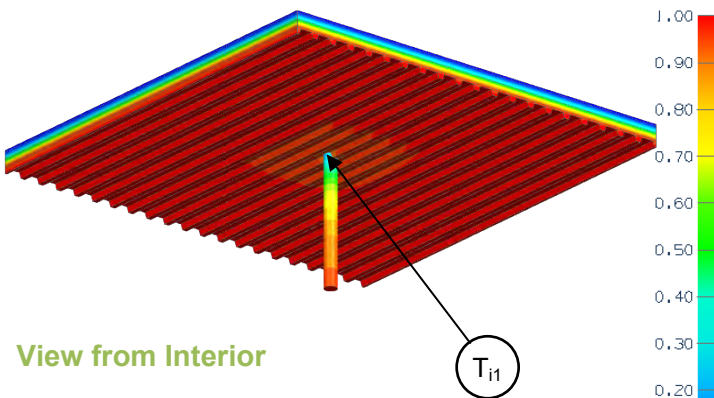

View from Interior

Thermal Performance Indicators

Assembly 1D (Nominal) R-Value	R_{1D}	R-3.5 (0.62 RSI) + Insulation
Transmittance / Resistance without Anomaly	U_o, R_o	"clear field" U- and R-value, without roof drain
Transmittance / Resistance	U, R	U- and R-values for the overall assembly
Surface Temperature Index ¹	T_i	0 = exterior temperature 1 = interior temperature
Point Transmittance	χ	Incremental increase in transmittance for drain

¹Surface temperatures are a result of steady-state conductive heat flow with constant heat transfer coefficients. Limitations are identified in final report.

Nominal (1D) vs. Assembly Performance Indicators

Base Assembly – Roof

Bottom Layer Roof Insulation 1D R-Value (RSI)	Top Layer Roof Insulation 1D R-Value (RSI)	R_{1D} ft ² ·hr·°F / Btu (m ² K / W)	R_o ft ² ·hr·°F / Btu (m ² K / W)	U_o Btu/ft ² ·hr·°F (W/m ² K)
R-11.4 (2.01)	R-9.9 (1.74)	R-24.9 (4.38)	R-24.1 (4.25)	0.041 (0.24)
R-22.8 (4.02)	R-9.9 (1.74)	R-36.3 (6.39)	R-35.5 (6.26)	0.028 (0.16)
R-34.2 (6.02)	R-9.9 (1.74)	R-47.7 (8.40)	R-46.9 (8.27)	0.021 (0.12)
R-45.6 (8.03)	R-9.9 (1.74)	R-59.1 (10.41)	R-58.3 (10.27)	0.017 (0.10)

Roof Drain Point Transmittance

R ft ² ·hr·°F / Btu (m ² K / W)	U Btu/ft ² ·hr·°F (W/m ² K)	χ Btu/hr·°F (W/K)
R-18.9 (3.33)	0.053 (0.30)	1.145 (0.604)
R-27.3 (4.81)	0.037 (0.21)	0.849 (0.448)
R-35.1 (6.18)	0.029 (0.16)	0.720 (0.380)
R-42.5 (7.49)	0.024 (0.13)	0.636 (0.336)

Temperature Indices

	R-11.4 + R9.9	R-22.8 + R-9.9	R-34.2 + R-9.9	R-45.6 + R-9.9	
T_{i1}	0.242	0.318	0.382	0.436	Drain penetration at steel deck